



# Atmel AT24C01C, Atmel AT24C02C Atmel AT24C04C, Atmel AT24C08C

---

## 2-wire Automotive Temperature Serial EEPROMs 1K (128 x 8), 2K (256 x 8), 4K (512 x 8), 8K (1024 x 8)

---

### DATASHEET

#### Features

---

- Medium-voltage and standard-voltage operation
  - 2.5 ( $V_{CC} = 2.5V$  to 5.5V)
- Automotive temperature range  $-40^{\circ}C$  to  $125^{\circ}C$
- Internally organized 128 x 8 (1K), 256 x 8 (2K), 512 x 8 (4K), or 1024 x 8 (8K)
- 2-wire serial interface
- Schmitt Trigger, filtered inputs for noise suppression
- Bidirectional data transfer protocol
- 400kHz (2.5V) compatibility
- Write Protect pin for hardware data protection
- 8-byte page (1K, 2K) or 16-byte page (4K, 8K) write modes
- Partial page writes are allowed
- Self-timed Write Cycle (5 ms max)
- High reliability
  - Endurance: 1,000,000 write cycles
  - Data retention: 100 years
- 8-lead JEDEC SOIC and 8-lead TSSOP packages

#### Description

---

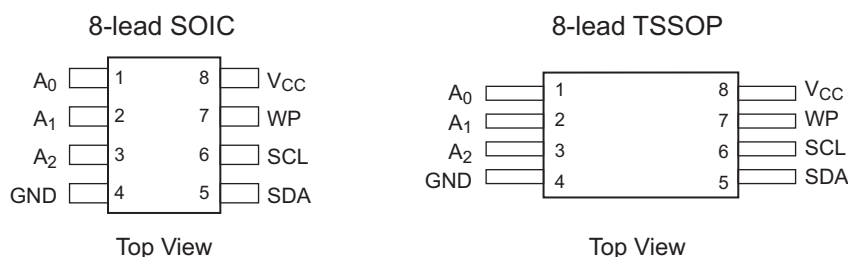
The Atmel® AT24C01C/02C/04C/08C provides 1024/2048/4096/8192 bits of Serial Electrically Erasable and Programmable Read-Only Memory (EEPROM) organized as 128/256/512/1024 words of eight bits each. The device is optimized for use in many automotive applications where low-power and low-voltage operation are essential. AT24C01C/02C/04C/08C is available in space-saving 8-lead JEDEC SOIC and 8-lead TSSOP packages and is accessed via a 2-wire serial interface. In addition, the entire family is available in 2.5V (2.5V to 5.5V) versions.

# 1. Pin Configurations and Pinouts

Table 1-1. Pin Configurations

Pin Name	Function
A <sub>0</sub>	Address Input (1K and 2K)
A <sub>1</sub>	Address Input (1K, 2K, and 4K)
A <sub>2</sub>	Address Input (1K, 2K, 4K, and 8K)
GND	Ground
SDA	Serial Data
SCL	Serial Clock Input
WP	Write Protect
V <sub>CC</sub>	Device Power Supply

Figure 1-1. Pinouts

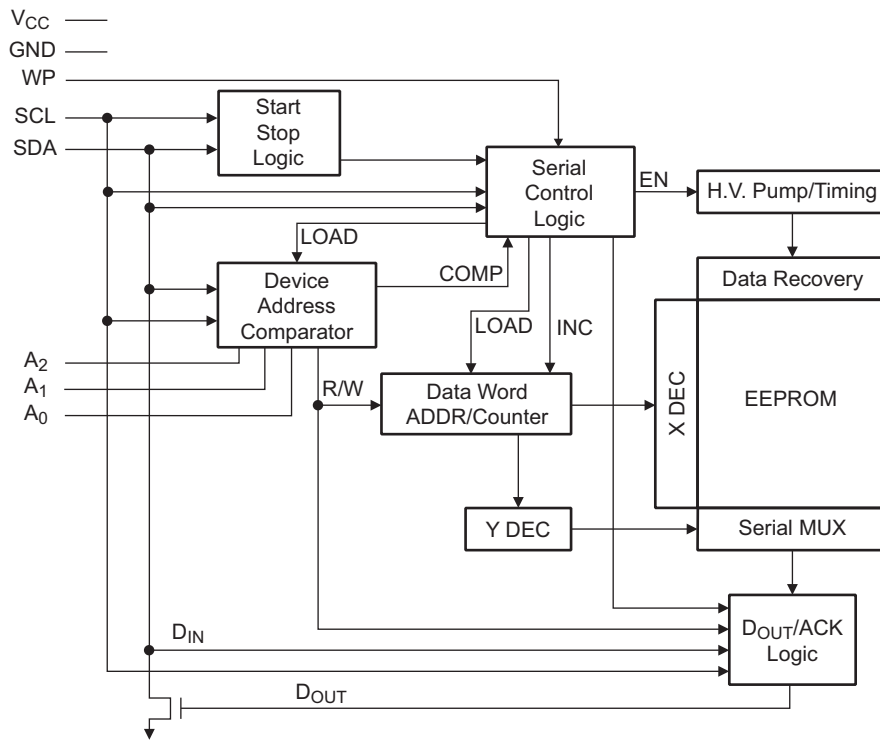


# 2. Absolute Maximum Ratings\*

Operating Temperature . . . . .	-55°C to +125°C
Storage Temperature . . . . .	-65°C to +150°C
Voltage on any pin with respect to ground . . . . .	-1.0V to +7.0V
Maximum Operating Voltage . . . . .	6.25V
DC Output Current . . . . .	.50mA

\*Notice: Stresses beyond those listed under “Absolute Maximum Ratings” may cause permanent damage to the device. This is a stress rating only and functional operation of the device at these or any other conditions beyond those indicated in the operational sections of this specification is not implied. Exposure to absolute maximum rating conditions for extended periods may affect device reliability.

### 3. Block Diagram



## 4. Pin Description

**Serial Clock (SCL):** The SCL input is used to positive edge clock data into each EEPROM device and negative edge clock data out of each device.

**Serial Data (SDA):** The SDA pin is bi-directional for serial data transfer. This pin is open-drain driven and may be wire-ORed with any number of other open-drain or open-collector devices.

**Device/Page Addresses (A<sub>2</sub>, A<sub>1</sub>, A<sub>0</sub>):** The A<sub>2</sub>, A<sub>1</sub>, and A<sub>0</sub> pins are device address inputs that are hard wired for the AT24C01C/02C/04C/08C. As many as eight 1K/2K devices may be addressed on a single bus system (device addressing is discussed in detail in [Section 6. “Device Operation”](#)).

The AT24C04C uses the A<sub>2</sub> and A<sub>1</sub> inputs for hardwire addressing and a total of four 4K devices may be addressed on a single bus system. The A<sub>0</sub> pin is a no connect.

The AT24C08C only uses the A<sub>2</sub> input for hardwire addressing and a total of two 8K devices may be addressed on a single bus system. The A<sub>0</sub> and A<sub>1</sub> pins are no connect.

**Write Protect (WP):** AT24C01C/02C/04C/08C has a Write Protect pin that provides hardware data protection. The Write Protect pin allows normal read/write operations when connected to ground (GND). When the Write Protect pin is connected to V<sub>CC</sub>, the write protection feature is enabled and operates as shown in the following table.

**Figure 4-1. Write Protect**

WP Pin Status	Part of the Array Protected
	AT24C01C/02C/04C/08C
At V <sub>CC</sub>	Full Array
At GND	Normal Read/Write Operations

## 5. Memory Organization

**AT24C01C, 1K Serial EEPROM:** Internally organized with 16 pages of 8 bytes each, the 1K requires a 7-bit data word address for random word addressing.

**AT24C02C, 2K Serial EEPROM:** Internally organized with 32 pages of 8 bytes each, the 2K requires an 8-bit data word address for random word addressing.

**AT24C04C, 4K Serial EEPROM:** Internally organized with 32 pages of 16 bytes each, the 4K requires a 9-bit data word address for random word addressing.

**AT24C08C, 8K Serial EEPROM:** Internally organized with 64 pages of 16 bytes each, the 8K requires a 10-bit data word address for random word addressing.

**Table 5-1. Pin Capacitance<sup>(1)</sup>**

Applicable over recommended operating range from  $T_A = 25^\circ\text{C}$ ,  $f = 400\text{KHz}$ ,  $V_{CC} = 2.5\text{V}$ .

Symbol	Test Condition	Max	Units	Conditions
$C_{I/O}$	Input/Output Capacitance (SDA)	8	pF	$V_{I/O} = 0\text{V}$
$C_{IN}$	Input Capacitance (A0, A1, A2, SCL)	6	pF	$V_{IN} = 0\text{V}$

Note: 1. This parameter is characterized and is not 100% tested.

**Table 5-2. DC Characteristics**

Applicable over recommended operating range from:  $T_A = -40^\circ\text{C}$  to  $+125^\circ\text{C}$ ,  $V_{CC} = 2.5\text{V}$  to  $5.5\text{V}$  (unless otherwise noted).

Symbol	Parameter	Test Condition	Min	Typ	Max	Units
$V_{CC1}$	Supply Voltage		2.5		5.5	V
$I_{CC}$	Supply Current $V_{CC} = 5.0\text{V}$	Read at 100kHz		0.4	1.0	mA
$I_{CC}$	Supply Current $V_{CC} = 5.0\text{V}$	Write at 100kHz		2.0	3.0	mA
$I_{SB1}$	Standby Current $V_{CC} = 2.5\text{V}$	$V_{IN} = V_{CC}$ or $V_{SS}$		1.6	4.0	$\mu\text{A}$
$I_{SB2}$	Standby Current $V_{CC} = 5.0\text{V}$	$V_{IN} = V_{CC}$ or $V_{SS}$		4.0	6.0	$\mu\text{A}$
$I_{LI}$	Input Leakage Current	$V_{IN} = V_{CC}$ or $V_{SS}$		0.10	3.0	$\mu\text{A}$
$I_{LO}$	Output Leakage Current	$V_{OUT} = V_{CC}$ or $V_{SS}$		0.05	3.0	$\mu\text{A}$
$V_{IL}$	Input Low Level <sup>(1)</sup>		-0.6		$V_{CC} \times 0.3$	V
$V_{IH}$	Input High Level <sup>(1)</sup>		$V_{CC} \times 0.7$		$V_{CC} + 0.5$	V
$V_{OL}$	Output Low Level $V_{CC} = 2.5\text{V}$	$I_{OL} = 3.0\text{mA}$			0.4	V

Note: 1.  $V_{IL}$  min and  $V_{IH}$  max are reference only and are not tested.

**Table 5-3. AC Characteristics**

Applicable over recommended operating range from  $T_A = -40^{\circ}\text{C}$  to  $125^{\circ}\text{C}$ ,  $V_{CC} = 2.5\text{V}$  to  $5.5\text{V}$ ,  
 $CL = 1$  TTL Gate and  $100\text{pF}$  (unless otherwise noted)

Symbol	Parameter	Min	Max	Units
$f_{SCL}$	Clock Frequency, SCL		400	kHz
$t_{LOW}$	Clock Pulse Width Low	1200		ns
$t_{HIGH}$	Clock Pulse Width High	600		ns
$t_I$	Noise Suppression Time <sup>(1)</sup>		50	ns
$t_{AA}$	Clock Low to Data Out Valid	100	90	ns
$t_{BUF}$	Time the bus must be free before a new transmission can start <sup>(2)</sup>	1200		ns
$t_{HD.STA}$	Start Hold Time	600		ns
$t_{SU.STA}$	Start Set-up Time	600		ns
$t_{HD.DAT}$	Data In Hold Time	0		ns
$t_{SU.DAT}$	Data In Set-up Time	100		ns
$t_R$	Inputs Rise Time <sup>(2)</sup>		300	ns
$t_F$	Inputs Fall Time <sup>(2)</sup>		300	ns
$t_{SU.STO}$	Stop Set-up Time	600		ns
$t_{DH}$	Data Out Hold Time	50		ns
$t_{WR}$	Write Cycle Time		5	ms
Endurance <sup>(2)</sup>	5.0V, $25^{\circ}\text{C}$ , Page Mode		1,000,000	Write Cycles

- Notes: 1. This parameter is characterized and is not 100% tested ( $T_A = 25^{\circ}\text{C}$ ).  
 2. This parameter is characterized only.

## 6. Device Operation

**Clock and Data Transitions:** The SDA pin is normally pulled high with an external device. Data on the SDA pin may change only during SCL low time periods (see [Figure 6-4 on page 9](#)). Data changes during SCL high periods will indicate a Start or Stop condition as defined below.

**Start Condition:** A high-to-low transition of SDA with SCL high is a Start condition which must precede any other command (see [Figure 6-5 on page 9](#)).

**Stop Condition:** A low-to-high transition of SDA with SCL high is a Stop condition. After a read sequence, the Stop command will place the EEPROM in a standby power mode (see [Figure 6-5 on page 9](#)).

**Acknowledge:** All addresses and data words are serially transmitted to and from the EEPROM in 8-bit words. The EEPROM sends a zero to acknowledge that it has received each word. When the EEPROM is reading data out, the host will transmit an ACK after each data word to indicate that the next word can be transmitted. This happens during the ninth clock cycle.

**Standby Mode:** AT24C01C/02C/04C/08C features a low-power standby mode which is enabled:

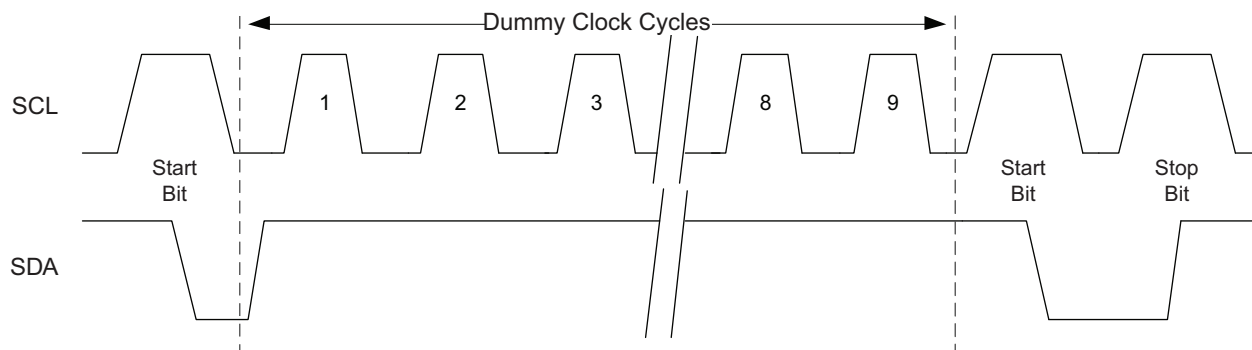
- Upon power-up.
- After the receipt of the Stop bit and the completion of any internal operations.

**2-wire Software Reset:** After an interruption in protocol, power loss, or system reset, any 2-wire part can be protocol reset by following these steps:

1. Create a Start bit condition.
2. Clock nine cycles.
3. Create another Start bit followed by Stop bit condition as shown in the following figures.

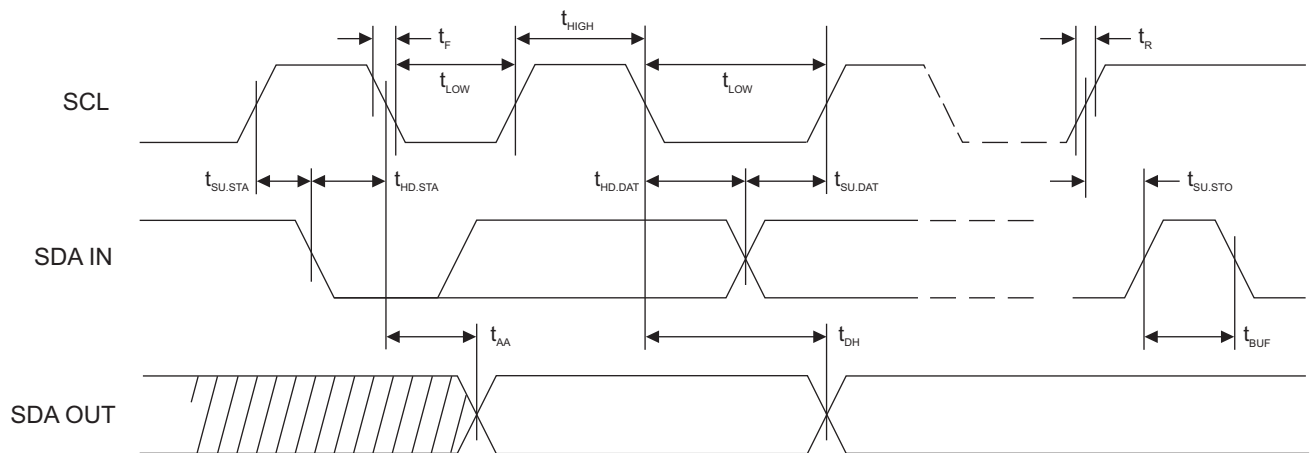
The device is ready for next communication after above steps have been completed.

**Figure 6-1. Software Reset**



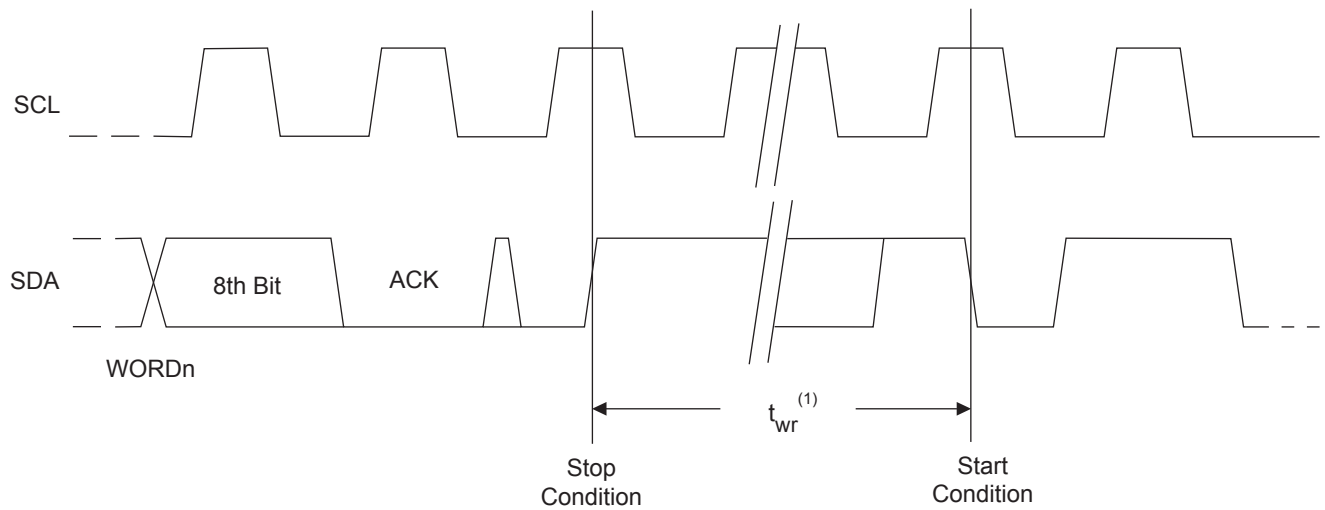
**Figure 6-2. Bus Timing**

SCL: Serial Clock, SDA: Serial Data I/O



**Figure 6-3. Write Cycle Timing**

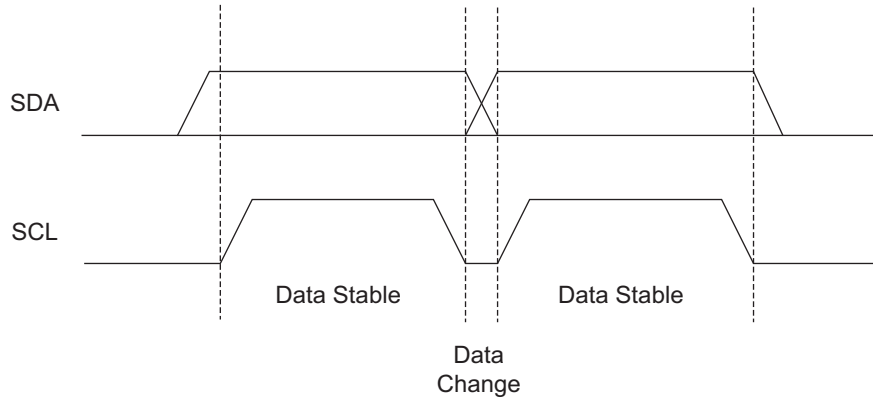
SCL: Serial Clock, SDA: Serial Data I/O



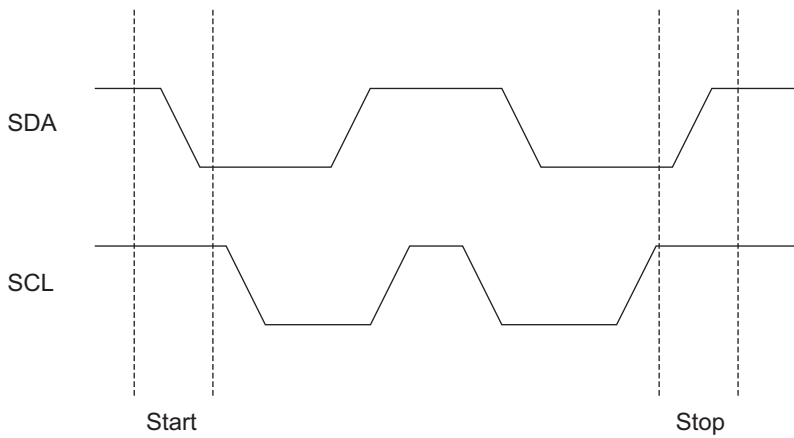
Note: 1. The write cycle time  $t_{WR}$  is the time from a valid Stop condition of a write sequence to the end of the internal clear/write cycle.



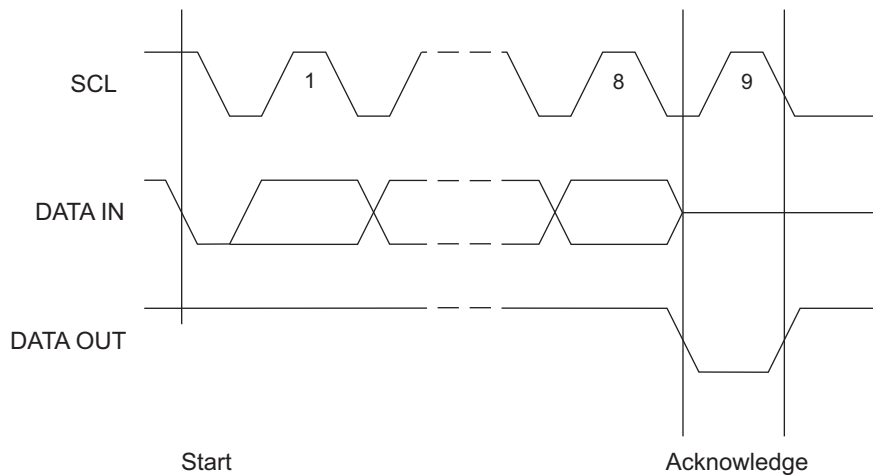
**Figure 6-4. Data Validity**



**Figure 6-5. Start and Stop Definition**



**Figure 6-6. Output Acknowledge**



## 7. Device Addressing

The 1K/2K/4K/8K EEPROM devices require an 8-bit device address word following a Start condition to enable the device for a read or write operation (see [Figure 9-1 on page 11](#)).

The device address word consists of a mandatory '1010' sequence for the first four Most Significant Bits (MSB) as shown. This is common to all the Serial EEPROM devices.

For the 1K/2K EEPROM, the next three bits are the A<sub>2</sub>, A<sub>1</sub>, and A<sub>0</sub> device address bits. These three bits must compare to their corresponding hardwired input A<sub>2</sub>, A<sub>1</sub>, and A<sub>0</sub> pins.

The 4K EEPROM only uses the A<sub>2</sub> and A<sub>1</sub> device address bits with the A<sub>0</sub> bit being a memory address bit (P<sub>0</sub>) (see [Figure 9-1 on page 11](#)). The two device address bits must compare to their corresponding hardwired input A<sub>2</sub> and A<sub>1</sub> pins. The A<sub>0</sub> pin is not connected.

The 8K EEPROM only uses the A<sub>2</sub> device address bit with the next two bits (P<sub>1</sub>, P<sub>0</sub>) being for memory page addressing (See [Figure 9-1 on page 11](#)). The A<sub>2</sub> bit must compare to its corresponding hardwired input pin. The A<sub>1</sub> and A<sub>0</sub> pins are not connected.

The eighth bit of the device address is the read/write operation select bit. A read operation is initiated if this bit is high and a write operation is initiated if this bit is low.

After a valid comparison of the device address, the EEPROM will output a zero. If the comparison is invalid, the device will return to a standby state.

## 8. Write Operations

**Byte Write:** A write operation requires an 8-bit data word address following the device address word and acknowledgment. Upon receipt of this address, the EEPROM will again respond with a zero and then clock in the first 8-bit data word. Following receipt of the 8-bit data word, the EEPROM will output a zero and the addressing device, such as a microcontroller, must terminate the write sequence with a Stop condition. At this time, the EEPROM enters an internally timed write cycle ( $t_{WR}$ ) to the nonvolatile memory. All inputs are disabled during this write cycle, and the EEPROM will not respond until the write is complete (see [Figure 9-2 on page 11](#)).

**Page Write:** The 1K/2K EEPROM are capable of an 8-byte Page Write. The 4K/8K EEPROM devices are capable of 16-byte Page Writes.

A Page Write is initiated the same as a Byte Write, but the microcontroller does not send a Stop condition after the first data word is clocked in. Instead, after the EEPROM acknowledges receipt of the first data word, the microcontroller can transmit up to seven (1K/2K) or fifteen (4K/ 8K) more data words. The EEPROM will respond with a zero after each data word received. The microcontroller must terminate the Page Write sequence with a Stop condition (see [Figure 9-3 on page 12](#)).

The data word address lower three (1K/2K) or four (4K/8K) bits are internally incremented following the receipt of each data word. The higher data word address bits are not incremented, retaining the memory page row location. When the word address, internally generated, reaches the page boundary, the next byte sent will be written to the beginning address on the same page. In other words, if more than eight (1K/2K) or sixteen (4K/8K) data words are transmitted to the EEPROM, the data word address will “roll over” and the data previously sent to the device at the beginning of the page write sequence will be altered.

**Acknowledge Polling:** Once the internally timed write cycle has started and the EEPROM inputs are disabled, Acknowledge Polling can be initiated. This involves sending a start condition followed by the device address word. The read/write bit is representative of the operation desired. Only if the internal write cycle has completed will the EEPROM respond with a zero, allowing the read or write sequence to continue.

## 9. Read Operations

Read operations are initiated the same way as write operations with the exception that the read/write select bit in the device address word is set to one. There are three read operations: Current Address Read, Random Address Read and Sequential Read.

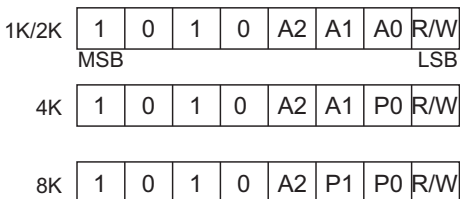
**Current Address Read:** The internal data word address counter maintains the last address accessed during the last read or write operation, incremented by one. This address stays valid between operations as long as the chip power is maintained. The address “roll over” during read is from the last byte of the last memory page to the first byte of the first page. The address “roll over” during write is from the last byte of the current page to the first byte of the same page.

Once the device address with the read/write select bit set to one is clocked in and acknowledged by the EEPROM, the current address data word is serially clocked out. To end the command, the microcontroller does not respond with a zero but does generate a Stop condition in the subsequent clock cycle. (see [Figure 9-4 on page 12](#)).

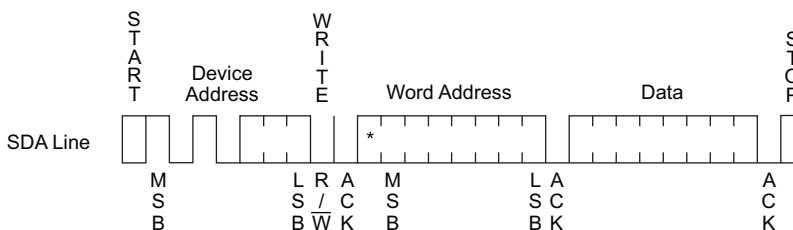
**Random Read:** A Random Read requires a dummy byte write sequence to load in the data word address. Once the device address word and data word address are clocked in and acknowledged by the EEPROM, the microcontroller must generate another Start condition. The microcontroller now initiates a Current Address Read by sending a device address with the read/write select bit high. The EEPROM acknowledges the device address and serially clocks out the data word. To end the command, the microcontroller does not respond with a zero but does generate a Stop condition in the subsequent clock cycle. (see [Figure 9-5 on page 12](#)).

**Sequential Read:** Sequential Reads are initiated by either a Current Address Read or a Random Address Read. After the microcontroller receives a data word, it responds with an acknowledge. As long as the EEPROM receives an acknowledge, it will continue to increment the data word address and serially clock out sequential data words. When the memory address limit is reached, the data word address will “roll over” and the Sequential Read will continue. To end the command, the microcontroller does not respond with a zero but does generate a Stop condition in the subsequent clock cycle. (see [Figure 9-6 on page 13](#)).

**Figure 9-1. Device Address**

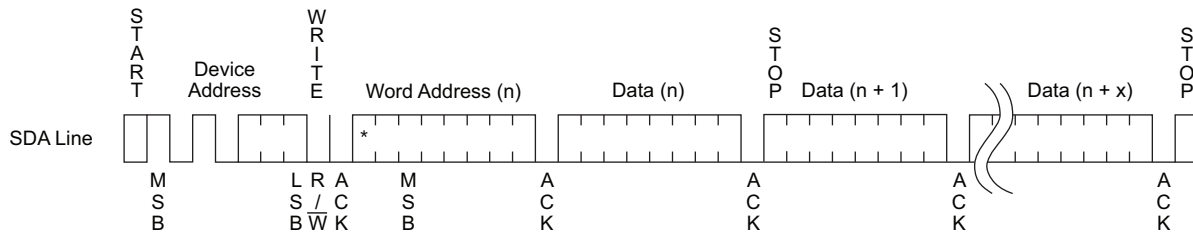


**Figure 9-2. Byte Write**



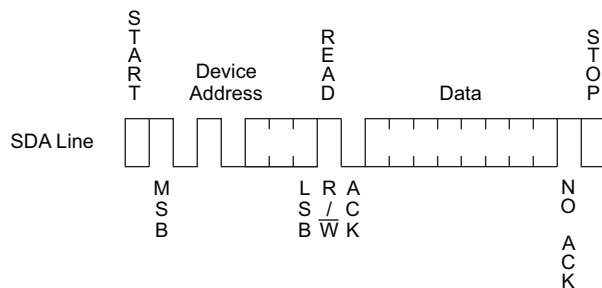
\* = Don't care bit for 1K

**Figure 9-3. Page Write**

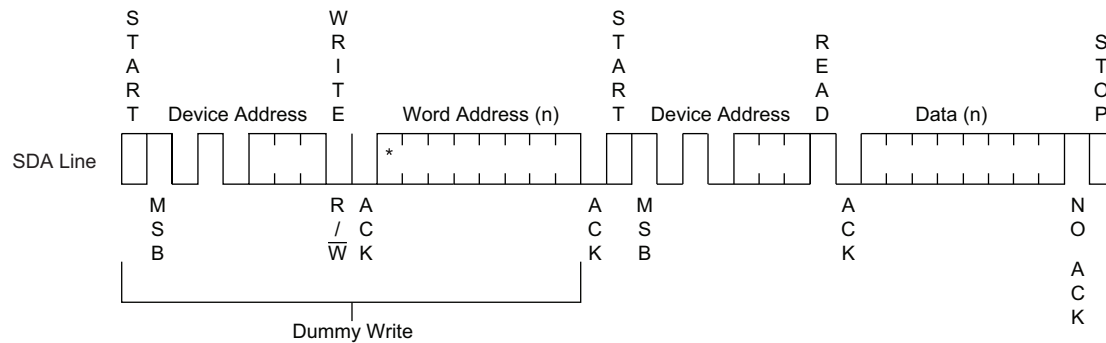


\* = Don't care bit for 1K

**Figure 9-4. Current Address Read**

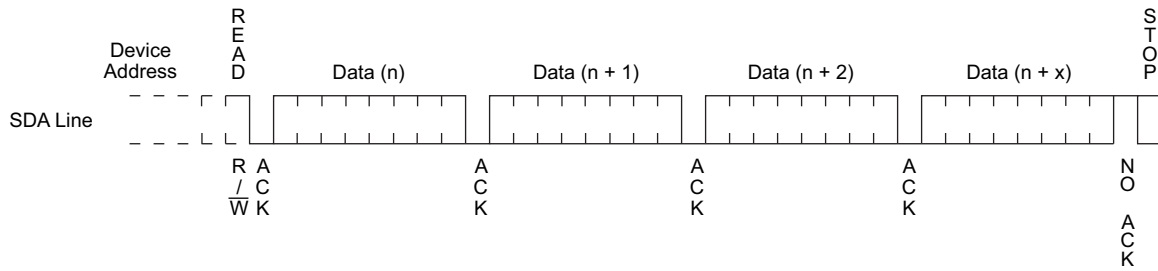


**Figure 9-5. Random Read**



\* = Don't care bit for 1K

Figure 9-6. Sequential Read

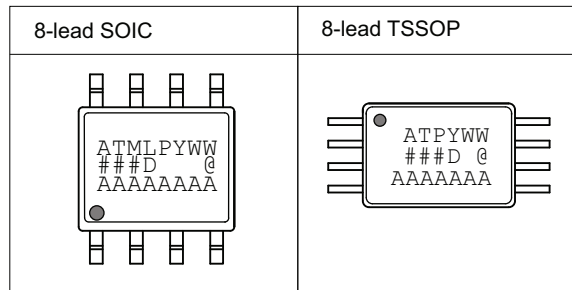


## 9.1 Power Recommendations

The device internal POR (Power-On Reset) threshold is just below the minimum device operating voltage. Power shall rise monotonically from 0.0Vdc to full  $V_{CC}$  in less than 1ms, and then be held at full  $V_{CC}$  for at least 100 $\mu$ s before the first operation. Power shall drop from full  $V_{CC}$  to 0.0Vdc in less than 1ms. Power dropping to a non-zero level and then slowly going to zero is not recommended. Power shall remain off (0.0Vdc) for 0.5s minimum. Please consult Atmel if your power conditions do not meet the above recommendations.

## 10. Product Markings

### AT24C01C, AT24C02C, AT24C04C and AT24C08C: Package Marking Information



Note 1: ● designates pin 1

Note 2: Package drawings are not to scale

Catalog Number Truncation		
AT24C01C	Truncation Code ###: 01C	
AT24C02C	Truncation Code ###: 02C	
AT24C04C	Truncation Code ###: 04C	
AT24C08C	Truncation Code ###: 08C	
Date Codes		Voltages
Y = Year	WW = Work Week of Assembly	% = Minimum Voltage
2: 2012    6: 2016	02:Week 2	D: 2.5V min
3: 2013    7: 2017	04:Week 4	
4: 2014    8: 2018	...	
5: 2015    9: 2019	52:Week 52	
Country of Assembly	Lot Number	Grade/Lead Finish Material
@ = Country of Assembly	AAA...A = Atmel Wafer Lot Number	P: Automotive/NiPdAu
		Atmel Truncation
		AT: Atmel ATM: Atmel ATML: Atmel

11/13/12

<p>Package Mark Contact: DL-CSO-Assy_eng@atmel.com</p>	<b>TITLE</b>	<b>DRAWING NO.</b>	<b>REV.</b>
	<b>24C01-02-04-08CAM</b> , AT24C01C, AT24C02C, AT24C04C, and AT24C08C Automotive Package Marking Information	24C01-02-04-08CAM	B

## 11. Ordering Code Information

Atmel Ordering Code	Lead Finish	Package	Voltage	Operation Range
AT24C01C-SSPD-T <sup>(1)</sup>	NiPdAu (Lead-free/Halogen-free)	8S1	2.5V to 5.5V	Automotive Temperature (-40°C to 125°C)
AT24C01C-XPD-T <sup>(1)</sup>		8X		
AT24C02C-SSPD-T <sup>(1)</sup>	NiPdAu (Lead-free/Halogen-free)	8S1	2.5V to 5.5V	Automotive Temperature (-40°C to 125°C)
AT24C02C-XPD-T <sup>(1)</sup>		8X		
AT24C04C-SSPD-T <sup>(1)</sup>	NiPdAu (Lead-free/Halogen-free)	8S1	2.5V to 5.5V	Automotive Temperature (-40°C to 125°C)
AT24C04C-XPD-T <sup>(1)</sup>		8X		
AT24C08C-SSPD-T <sup>(1)</sup>	NiPdAu (Lead-free/Halogen-free)	8S1	2.5V to 5.5V	Automotive Temperature (-40°C to 125°C)
AT24C08C-XPD-T <sup>(1)</sup>		8X		

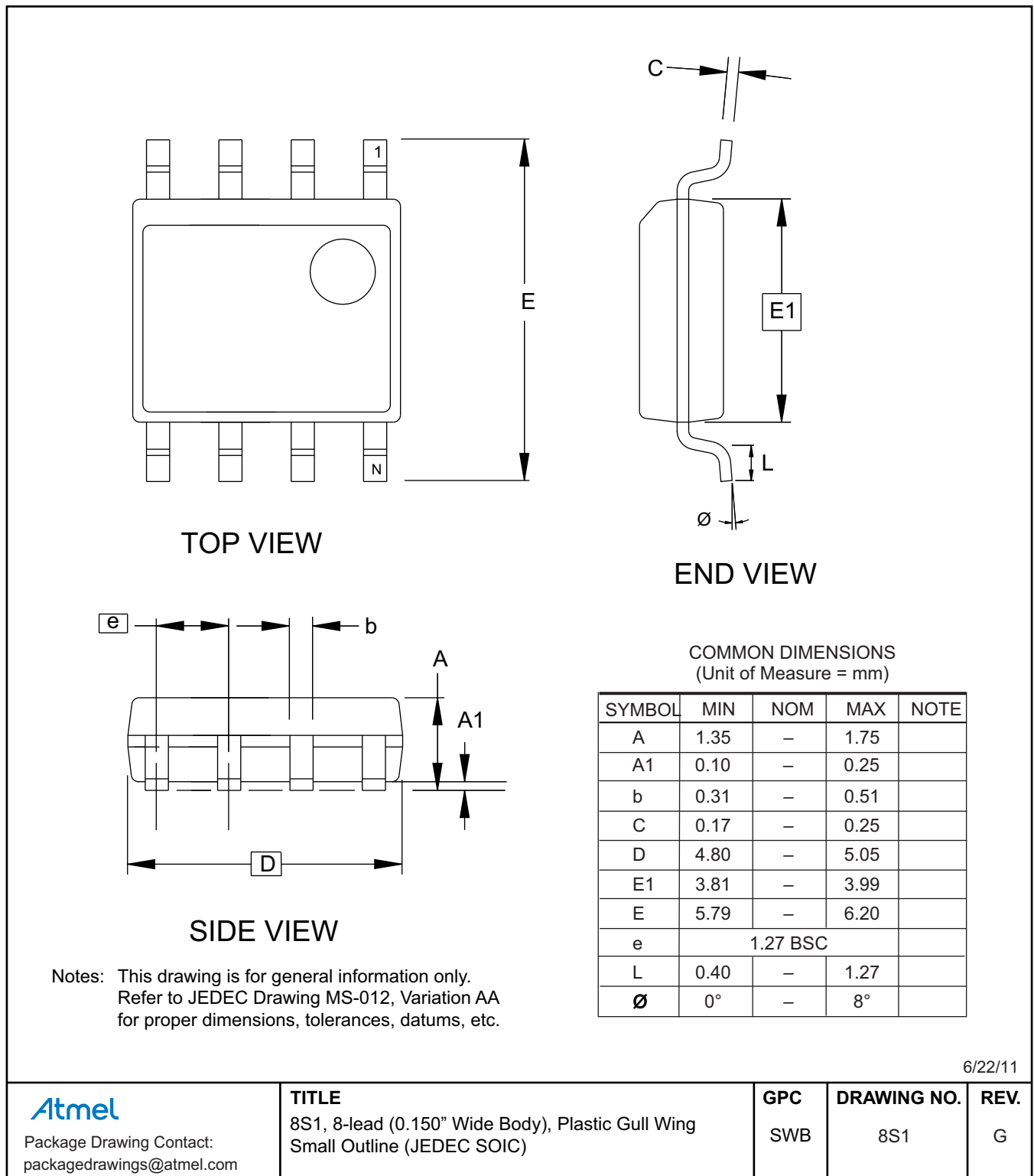
Note: 1. T = Tape and reel.

- SOIC 4K per reel.
- TSSOP 5K per reel.

Package Type	
<b>8S1</b>	8-lead, 0.150" wide, Plastic Gull Wing Small Outline (JEDEC SOIC).
<b>8X</b>	8-lead, 4.4mm body, Plastic Thin Shrink Small Outline (TSSOP).

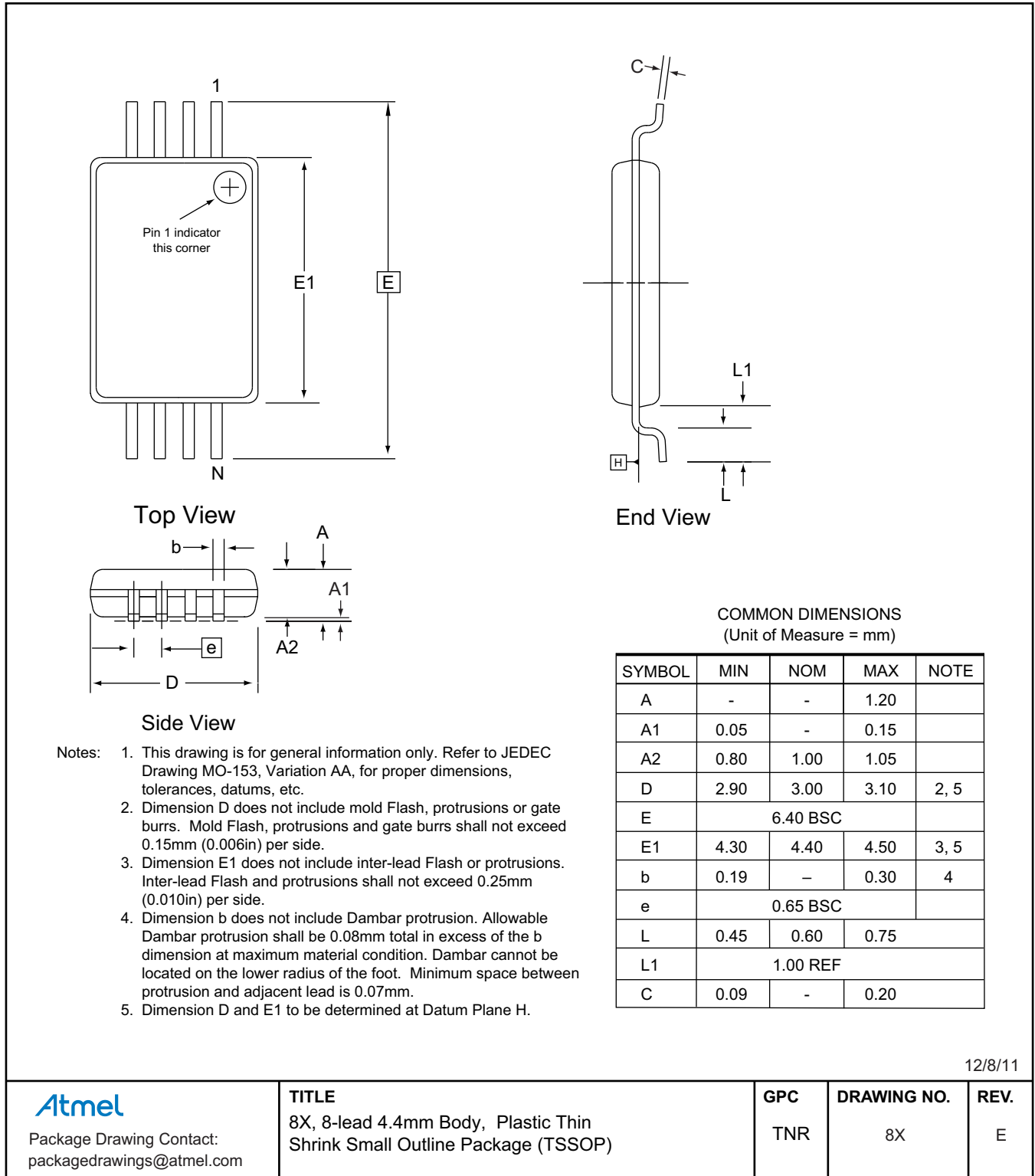
## 12. Packaging Information

### 12.1 8S1 — 8-lead JEDEC SOIC





## 12.2 8X — 8-lead TSSOP



### 13. Revision History

Doc. Rev.	Date	Comments
8819A	12/2012	Initial document release.



Enabling Unlimited Possibilities®

**Atmel Corporation**

2325 Orchard Parkway  
San Jose, CA 95131  
USA

**Tel:** (+1) (408) 441-0311

**Fax:** (+1) (408) 487-2600

[www.atmel.com](http://www.atmel.com)

**Atmel Asia Limited**

Unit 01-5 & 16, 19F  
BEA Tower, Millennium City 5  
418 Kwun Tong Roa

Kwun Tong, Kowloon

HONG KONG

**Tel:** (+852) 2245-6100

**Fax:** (+852) 2722-1369

**Atmel Munich GmbH**

Business Campus  
Parkring 4  
D-85748 Garching b. Munich  
GERMANY

**Tel:** (+49) 89-31970-0

**Fax:** (+49) 89-3194621

**Atmel Japan G.K.**

16F Shin-Osaki Kangyo Bldg  
1-6-4 Osaki, Shinagawa-ku  
Tokyo 141-0032  
JAPAN

**Tel:** (+81) (3) 6417-0300

**Fax:** (+81) (3) 6417-0370

© 2012 Atmel Corporation. All rights reserved. / Rev.: Atmel-8818A-SEEPROM-AT24C01C/02C/04C/08C-DATASHEET-12/2012

Atmel®, Atmel logo and combinations thereof, Enabling Unlimited Possibilities®, and others are registered trademarks or trademarks of Atmel Corporation or its subsidiaries. Other terms and product names may be trademarks of others.

Disclaimer: The information in this document is provided in connection with Atmel products. No license, express or implied, by estoppel or otherwise, to any intellectual property right is granted by this document or in connection with the sale of Atmel products. EXCEPT AS SET FORTH IN THE ATMEL TERMS AND CONDITIONS OF SALES LOCATED ON THE ATMEL WEBSITE, ATMEL ASSUMES NO LIABILITY WHATSOEVER AND DISCLAIMS ANY EXPRESS, IMPLIED OR STATUTORY WARRANTY RELATING TO ITS PRODUCTS INCLUDING, BUT NOT LIMITED TO, THE IMPLIED WARRANTY OF MERCHANTABILITY, FITNESS FOR A PARTICULAR PURPOSE, OR NON-INFRINGEMENT. IN NO EVENT SHALL ATMEL BE LIABLE FOR ANY DIRECT, INDIRECT, CONSEQUENTIAL, PUNITIVE, SPECIAL OR INCIDENTAL DAMAGES (INCLUDING, WITHOUT LIMITATION, DAMAGES FOR LOSS AND PROFITS, BUSINESS INTERRUPTION, OR LOSS OF INFORMATION) ARISING OUT OF THE USE OR INABILITY TO USE THIS DOCUMENT, EVEN IF ATMEL HAS BEEN ADVISED OF THE POSSIBILITY OF SUCH DAMAGES. Atmel makes no representations or warranties with respect to the accuracy or completeness of the contents of this document and reserves the right to make changes to specifications and products descriptions at any time without notice. Atmel does not make any commitment to update the information contained herein. Unless specifically provided otherwise, Atmel products are not suitable for, and shall not be used in, automotive applications. Atmel products are not intended, authorized, or warranted for use as components in applications intended to support or sustain life.