



## Dual, 12-Bit, 40MSPS Digital-to-Analog Converter

### FEATURES

- Dual, 12-Bit, 40MSPS Current Output DAC
- Four 12-Bit Voltage Output DACs—for Transmit Control
- Single +3V Operation
- Very Low Power: 29mW
- High SFDR: 75dB at  $f_{OUT} = 5\text{MHz}$
- Low-Current Standby or Full Power-Down Modes
- Internal Reference
- Optional External Reference
- Adjustable Full-Scale Range: 0.5mA to 2mA

### APPLICATIONS

- Transmit Channels
  - I and Q
  - PC Card Modems: GPRS, CDMA
  - Wireless Network Cards (NICs)
- Signal Synthesis (DDS)
- Portable Medical Instrumentation
- Arbitrary Waveform Generation (AWG)

### DESCRIPTION

The DAC2932 is a dual 12-bit, current-output digital-to-analog converter (DAC) designed to combine the features of high dynamic range and very low power consumption. The DAC2932 converter supports update rates of up to 40MSPS. In addition, the DAC2932 features four 12-bit voltage output DACs, which can be used to perform system control functions.

The advanced segmentation architecture of the DAC2932 is optimized to provide a high spurious-free dynamic range (SFDR).

The DAC2932 has a high impedance ( $> 200\text{k}\Omega$ ) differential current output with a nominal range of 2mA and a compliance voltage of up to 0.8V. The differential outputs allow for either a differential or single-ended analog signal interface. The close matching of the current outputs ensures superior dynamic performance in the differential configuration, which can be implemented with a transformer. Using a small geometry CMOS process, the monolithic DAC2932 is designed to operate within a single-supply range of 2.7V to 3.3V. Low power consumption makes it ideal for portable and battery-operated systems. Further optimization by lowering the output current can be realized with the adjustable full-scale option. The full-scale output current can be adjusted over a span of 0.5mA to 2mA.

For noncontinuous operation of the DAC2932, a full power-down mode can reduce the power dissipation to as little as  $25\mu\text{W}$ .

The DAC2932 is designed to operate with a single parallel data port. While it alternates the loading of the input data into separate input latches for both current output DACs (I-DACs), the updating of the analog output signal occurs simultaneously. The DAC2932 integrates a temperature compensated 1.22V bandgap reference. The DAC2932 also allows for additional flexibility of using an external reference.

The DAC2932 is available in a TQFP-48 package.



Please be aware that an important notice concerning availability, standard warranty, and use in critical applications of Texas Instruments semiconductor products and disclaimers thereto appears at the end of this data sheet.

All trademarks are the property of their respective owners.

**ORDERING INFORMATION**

PRODUCT	PACKAGE-LEAD	PACKAGE DESIGNATOR(1)	SPECIFIED TEMPERATURE RANGE	PACKAGE MARKING	ORDERING NUMBER	TRANSPORT MEDIA, QUANTITY
DAC2932	TQFP-48	PFB	-40°C to +85°C	DAC2932	DAC2932PFBT	Tape and Reel, 250
					DAC2932PFBR	Tape and Reel, 2000

(1) For the most current specification and package information, refer to our web site at [www.ti.com](http://www.ti.com).

**ABSOLUTE MAXIMUM RATINGS**

over operating free-air temperature range unless otherwise noted

	DAC2932	UNIT
+V <sub>A</sub> to AGND	-0.3 to +4	V
+V <sub>D</sub> to DGND	-0.3 to +4	V
AGND to DGND	-0.2 to +0.2	V
+V <sub>A</sub> to +V <sub>D</sub>	-0.7 to +0.7	V
CLK, PD, STBY, CS to DGND	-0.3 to V <sub>D</sub> + 0.3	V
D0–D11 to DGND	-0.3 to V <sub>D</sub> + 0.3	V
I <sub>OUT</sub> , I <sub>OUT</sub> to AGND	-0.5 to V <sub>A</sub> + 0.3	V
REFV to AGNDV	-0.3 to V <sub>AV</sub> + 0.3	V
GSET, REF <sub>IN</sub> , FSA to AGND	-0.3 to V <sub>A</sub> + 0.3	V
V <sub>OUTx</sub> to AGNDV	-0.3 to V <sub>AV</sub> + 0.3	V
DIN to DGNDV	-0.3 to V <sub>DV</sub> + 0.3	V
Junction temperature	+150	°C
Case temperature	+100	°C
Storage temperature range	-40 to +150	°C



This integrated circuit can be damaged by ESD. Texas Instruments recommends that all integrated circuits be handled with appropriate precautions. Failure to observe proper handling and installation procedures can cause damage.

ESD damage can range from subtle performance degradation to complete device failure. Precision integrated circuits may be more susceptible to damage because very small parametric changes could cause the device not to meet its published specifications.

**FUNCTIONAL BLOCK DIAGRAM**

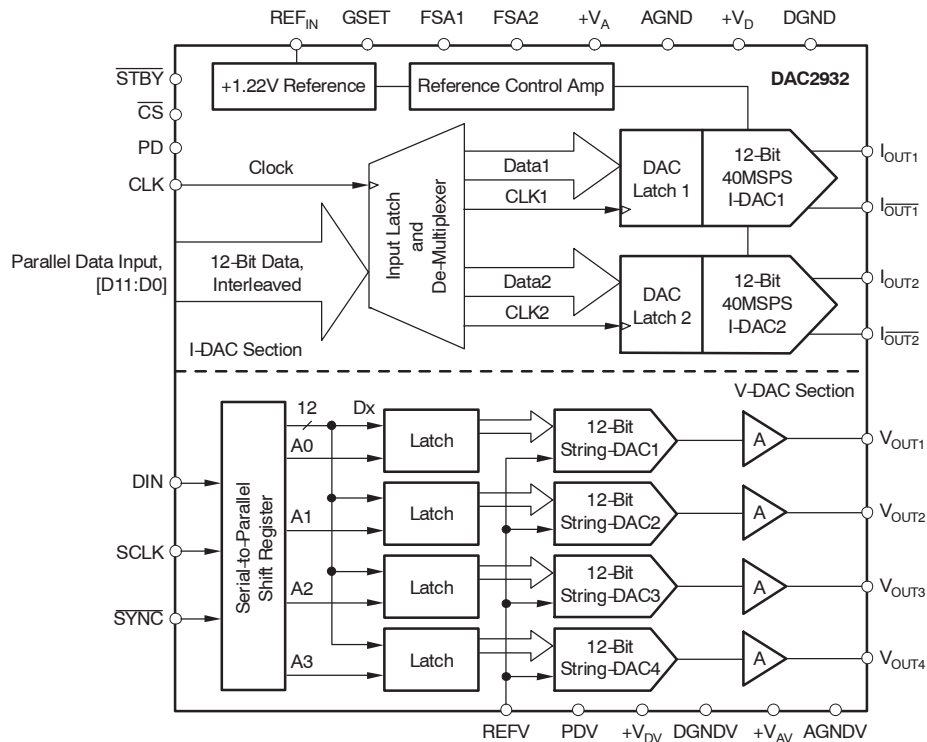

**ELECTRICAL CHARACTERISTICS: I-DAC**

At  $T_A = T_{MIN}$  to  $T_{MAX}$  (typical values are at  $T_A = 25^\circ\text{C}$ ),  $+V_A = +3\text{V}$ ,  $+V_D = +3\text{V}$ , Update Rate = 40MSPS,  $I_{OUTFS} = 2\text{mA}$ ,  $R_L = 250\Omega$ ,  $C_L \leq 10\text{pF}$ , GSET = H, and internal reference, unless otherwise noted.

PARAMETER	TEST CONDITIONS	DAC2932			UNITS
		MIN	TYP	MAX	
<b>Resolution</b>			12		Bits
Output update rate ( $f_{CLOCK}$ )			40		MSPS
Specified temperature range, operating	Ambient, $T_A$	-40		+85	$^\circ\text{C}$
<b>Static Accuracy<sup>(1)(2)</sup></b>					
Differential nonlinearity (DNL)		-3.5	$\pm 0.5$	+3.5	LSB
Integral nonlinearity (INL)		-8	$\pm 1.5$	+8	LSB
<b>Dynamic Performance<sup>(3)</sup></b>					
Spurious-free dynamic range (SFDR)	To Nyquist, 0dBFS				
$f_{OUT} = 0.2\text{MHz}$ , $f_{CLOCK} = 20\text{MSPS}$			68		dBc
$f_{OUT} = 0.55\text{MHz}$ , $f_{CLOCK} = 40\text{MSPS}$			71		dBc
$f_{OUT} = 1\text{MHz}$ , $f_{CLOCK} = 25\text{MSPS}^{(4)}$		58	70		dBc
$f_{OUT} = 2.2\text{MHz}$ , $f_{CLOCK} = 40\text{MSPS}$			72		dBc
$f_{OUT} = 5\text{MHz}$ , $f_{CLOCK} = 40\text{MSPS}$			75		dBc
$f_{OUT} = 10\text{MHz}$ , $f_{CLOCK} = 40\text{MSPS}$			69		dBc
$f_{OUT} = 20\text{MHz}$ , $f_{CLOCK} = 40\text{MSPS}$			57		dBc
Spurious-free dynamic range within a window					
$f_{OUT} = 2.2\text{MHz}$ , $f_{CLOCK} = 40\text{MSPS}$	1MHz span		76		dBc
$f_{OUT} = 10\text{MHz}$ , $f_{CLOCK} = 40\text{MSPS}$	2MHz span		74		dBc
Total harmonic distortion (THD)					
$f_{OUT} = 0.55\text{MHz}$ , $f_{CLOCK} = 40\text{MSPS}$			-70		dBc
$f_{OUT} = 1\text{MHz}$ , $f_{CLOCK} = 25\text{MSPS}^{(4)}$		-58	-69		dBc
$f_{OUT} = 2.2\text{MHz}$ , $f_{CLOCK} = 40\text{MSPS}$			-70		dBc
Signal-to-noise and distortion (SINAD)					
$f_{OUT} = 1\text{MHz}$ , $f_{CLOCK} = 25\text{MSPS}^{(4)}$		52	61		dBc
Output settling time <sup>(1)</sup>	to 0.1%		20		ns
Output rise time <sup>(1)</sup>	10% to 90%		7.7		ns
Output fall time <sup>(1)</sup>	10% to 90%		7.4		ns
<b>DC Accuracy</b>					
Full-scale output range <sup>(5)(6)</sup> (FSR)	All bits high, $I_{OUT1}$ , $I_{OUT2}$	0.5		2	mA
Output compliance range <sup>(7)</sup> , $V_{CO}$		-0.5	+0.5	+0.8	V
Gain error (Full-Scale)		-2	$\pm 0.5$	+2	%FSR
Gain error drift			70		ppmFSR/ $^\circ\text{C}$
Gain matching		-2.5	+0.6	+2.5	%FSR
Offset error			$\pm 0.001$		%FSR
Power-supply rejection, $+V_A$	+3V, $\pm 10\%$ , at $25^\circ\text{C}$	-0.9	+0.5	+0.9	%FSR/V
Power-supply rejection, $+V_D$	+3V, $\pm 10\%$ , at $25^\circ\text{C}$	-0.12	+0.03	+0.12	%FSR/V
Output resistance			200		k $\Omega$
Output capacitance	$I_{OUT1}$ , $I_{OUT2}$ to Ground		5		pF

(1) At output  $I_{OUT1}$ ,  $I_{OUT2}$ , while driving a 250 $\Omega$  load, transition from 000h to FFFh.

(2) Measured at  $f_{CLOCK} = 25\text{MSPS}$  and  $f_{OUT} = 1.0\text{MHz}$ .

(3) Differential, transformer ( $n = 4:1$ ) coupled output,  $R_L = 400\Omega$ .

(4) Differential outputs with a 250 $\Omega$  load.

(5) Nominal full-scale output current is  $I_{OUTFS} = 32 \times I_{REF} = 32 \times \frac{V_{REF}}{R_{SET}}$ ; with  $V_{REF} = 1.22\text{V}$  (typ) and  $R_{SET} = 19.6\text{k}\Omega$  (1%)

(6) Ensured by design and characterization; not production tested.

(7) Gain error to remain  $\leq 10\%$  FSR over the full compliance range.

(8) Combined power dissipation of I-DAC and V-DAC.

**ELECTRICAL CHARACTERISTICS: I-DAC (continued)**

At  $T_A = T_{MIN}$  to  $T_{MAX}$  (typical values are at  $T_A = 25^\circ\text{C}$ ),  $+V_A = +3\text{V}$ ,  $+V_D = +3\text{V}$ , Update Rate = 40MSPS,  $I_{OUTFS} = 2\text{mA}$ ,  $R_L = 250\Omega$ ,  $C_L \leq 10\text{pF}$ , GSET = H, and internal reference, unless otherwise noted.

PARAMETER	TEST CONDITIONS	DAC2932			UNITS
		MIN	TYP	MAX	
<b>Reference</b>					
Voltage, $V_{REF}$	External $V_{REF}$	+1.14	+1.22	+1.26	V
Tolerance			$\pm 30$		mV
Voltage drift				-40	ppm/ $^\circ\text{C}$
Output current				10	$\mu\text{A}$
Input resistance				1	M $\Omega$
Input compliance range				+1.22	V
Small-signal bandwidth				0.1	MHz
<b>Digital Inputs<sup>(6)</sup></b>					
Logic coding		Straight binary			
Logic high voltage, $V_{IH}$		+2	+3		V
Logic low voltage, $V_{IL}$			0	+0.8	V
Logic high current			$\pm 1$		$\mu\text{A}$
Logic low current			$\pm 1$		$\mu\text{A}$
Input capacitance			5		pF
<b>Power Supply</b>					
Analog supply voltage, $+V_A$ , $+V_{AV}$		2.7	3	3.3	V
Digital supply voltage, $+V_D$ , $+V_{DV}$		2.7	3	3.3	V
Analog supply current, $I_{VA}$	$f_{CLOCK} = 25\text{MSPS}$ , digital inputs at 0		4.7		mA
$I_{VA}$	$f_{CLOCK} = 40\text{MSPS}$ , $f_{OUT} = 2.2\text{MHz}$		5.4		mA
$I_{VA}$	Standby mode		0.4		mA
Digital supply current, $I_{VD}$	$f_{CLOCK} = 25\text{MSPS}$ , digital inputs at 0		2		mA
$I_{VD}$	$f_{CLOCK} = 40\text{MSPS}$ , $f_{OUT} = 2.2\text{MHz}$		4.3		mA
$I_{VD}$	Standby mode, clock off		0.02		mA
$I_{VD}$	Standby mode, $\overline{CS} = 0$ , $f_{CLOCK} = 25\text{MSPS}$		1.3		mA
Power dissipation, $PD^{(8)}$	$f_{CLOCK} = 25\text{MSPS}$ , digital inputs at 0		20	25	mW
$PD$	$f_{CLOCK} = 40\text{MSPS}$ , $f_{OUT} = 2.2\text{MHz}$		29		mW
$PD$	Standby mode, $f_{CLOCK} = 25\text{MSPS}$		5.5	7	mW
$PD$	Power-down mode, clock off, digital inputs at 0		25		$\mu\text{W}$
Thermal resistance					
TQFP-48 $\theta_{JA}$			97.5		$^\circ\text{C/W}$
$\theta_{JC}$			20		$^\circ\text{C/W}$

(1) At output  $I_{OUT1}$ ,  $I_{OUT2}$ , while driving a 250 $\Omega$  load, transition from 000h to FFFh.

(2) Measured at  $f_{CLOCK} = 25\text{MSPS}$  and  $f_{OUT} = 1.0\text{MHz}$ .

(3) Differential, transformer ( $n = 4:1$ ) coupled output,  $R_L = 400\Omega$ .

(4) Differential outputs with a 250 $\Omega$  load.

(5) Nominal full-scale output current is  $I_{OUTFS} = 32 \times I_{REF} = 32 \times \frac{V_{REF}}{R_{SET}}$ ; with  $V_{REF} = 1.22\text{V}$  (typ) and  $R_{SET} = 19.6\text{k}\Omega$  (1%)

(6) Ensured by design and characterization; not production tested.

(7) Gain error to remain  $\leq 10\%$  FSR over the full compliance range.

(8) Combined power dissipation of I-DAC and V-DAC.

**ELECTRICAL CHARACTERISTICS: V-DAC**

 At  $T_A = T_{MIN}$  to  $T_{MAX}$  (typical values are at  $T_A = 25^\circ\text{C}$ ),  $+V_{AV} = +3\text{V}$ ,  $+V_{DV} = +3\text{V}$ ,  $R_L = 2\text{k}\Omega$  to GND, and  $C_L = 40\text{pF}$ , unless otherwise noted.

PARAMETER	TEST CONDITIONS	DAC2932			UNITS
		MIN	TYP	MAX	
<b>Static Performance<sup>(1)</sup></b>					
Resolution			12		Bits
Relative accuracy	At $25^\circ\text{C}$	-16	$\pm 8$	+16	LSB
Differential nonlinearity, DNL	Tested; monotonic by design	-1	$\pm 0.2$	+1	LSB
Zero code error <sup>(2)</sup>	All 0s loaded to DAC register		0.2	+0.8	%FSR
Full-scale error <sup>(2)</sup>	All 1s loaded to DAC register	-10	-3	+2	%FSR
Zero code error drift			5		$\mu\text{V}/^\circ\text{C}$
Full-scale error drift			-15		ppmFSR/ $^\circ\text{C}$
<b>Output Characteristics<sup>(3)</sup></b>					
Reference voltage setting, REFV		0		$+V_{AV}$	V
Output voltage settling time	1/4 scale to 3/4 scale change (400h to C00h) $C_L = 470\text{pF}$		3		$\mu\text{s}$
			5		$\mu\text{s}$
Slew rate			1		$\text{V}/\mu\text{s}$
Capacitive load stability	$R_L = 2\text{k}\Omega$		470		pF
Code change glitch impulse	1LSB change around major carry		11		nV-s
Digital feedthrough			0.5		nV-s
DC output impedance			4		$\Omega$
Short-circuit current			20		mA
Power-up time	Coming out of power-down mode		8		$\mu\text{s}$
<b>Logic Inputs<sup>(3)</sup></b>					
Input current			$\pm 1$		$\mu\text{A}$
Input low voltage, $V_{IL}$			0	0.8	V
Input high voltage, $V_{IH}$		2	3		V
Input capacitance			5		pF

(1) Linearity calculated using a reduced code range of 48 to 3976.

 (2) Full-scale range (FSR) based on reference  $\text{REFV} = +V_{AV} = +3.0\text{V}$ .

(3) Ensured by design and characterization; not production tested.

**TIMING INFORMATION**

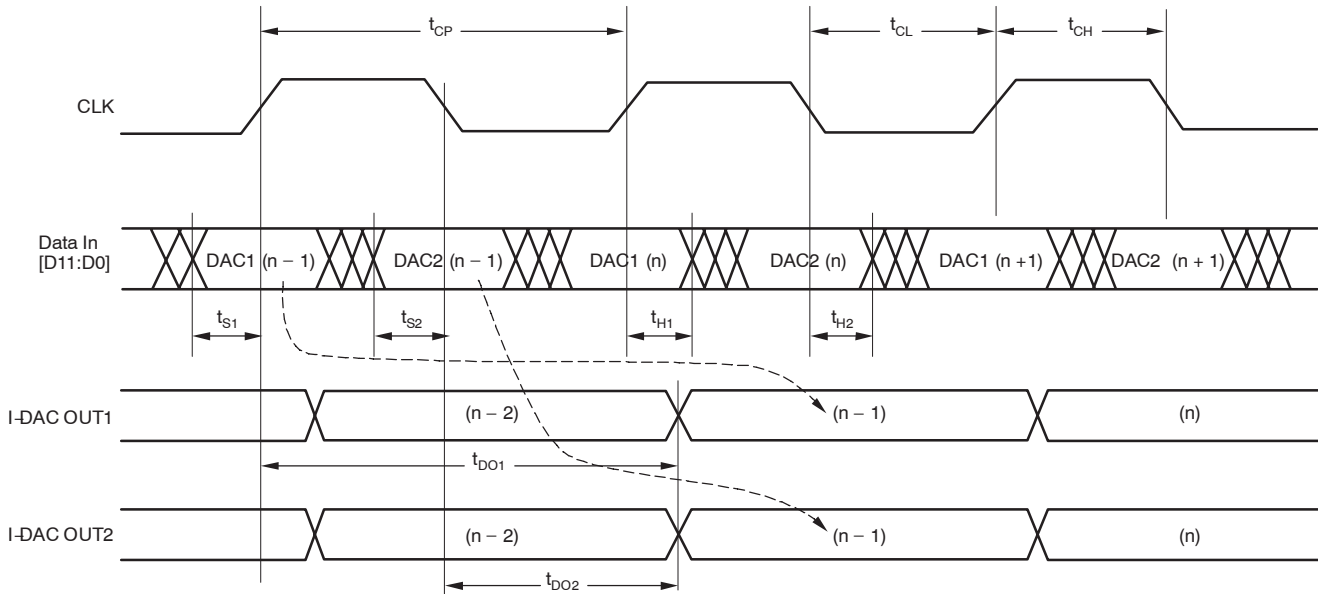

**Figure 1. Timing Diagram of I-DAC**

**TIMING REQUIREMENTS(1,2): I-DAC**

PARAMETER	DESCRIPTION	MIN	TYP	MAX	UNIT
$t_{CP}$	Clock cycle time (period)		25		ns
$t_{CL}$	Clock low time	10			ns
$t_{CH}$	Clock high time	10			ns
$t_{S1}$	Data setup time, I-DAC1	1	5		ns
$t_{S2}$	Data setup time, I-DAC2	1	5		ns
$t_{H1}$	Data hold time, I-DAC1	3.35	5		ns
$t_{H2}$	Data hold time, I-DAC2	3.35	5		ns
$t_{DO1}^{(3)}$	Output delay time, I-DAC1		$t_{S1} + t_{CP}$		ns
$t_{DO2}^{(3)}$	Output delay time, I-DAC2		$t_{S2} + (t_{CP}/2)$		ns
	$\overline{CS}$ hold time (pulse width)	2.49			ns
	$\overline{CS}$ to clock rising or falling edge setup time		0.52		ns
	$\overline{STBY}$ rise time to $I_{OUT}$		17		$\mu s$
	PD fall time to $I_{OUT}$ (I-DAC coming out of power-down mode)		22		$\mu s$

(1) Based on design simulation and characterization; not production tested.

(2) All input signals are specified with  $t_r = t_f \leq 2ns$  (10% to 90% of  $+V_{DV}$ ) and timed from a voltage level of  $(V_{IL} + V_{IH})/2$ .

(3) Output delay time measured from 50% of rising clock edge to 50% point of full-scale transition.

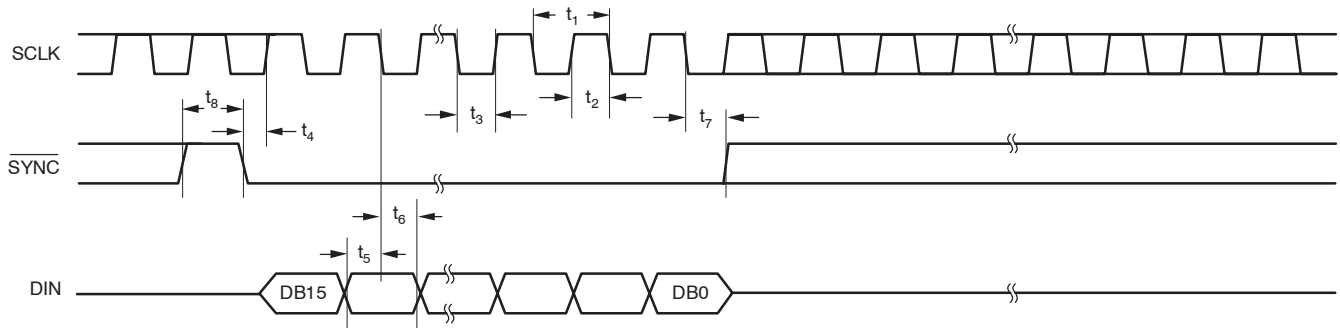

**Figure 2. Serial Write Operation of V-DAC**

**TIMING REQUIREMENTS(1,2): V-DAC**

PARAMETER	DESCRIPTION	MIN	TYP	MAX	UNIT
$t_1^{(3)}$	SCLK cycle time	50			ns
$t_2$	SCLK high time	13			ns
$t_3$	SCLK low time	22.5			ns
$t_4$	SYNC to SCLK rising edge setup time	0			ns
$t_5$	Data setup time	5	7.5		ns
$t_6$	Data hold time	1.5	2.5		ns
$t_7$	SCLK falling edge to SYNC rising edge	0	-6.0		ns
$t_8$	Minimum SYNC high time	50			ns
	PDV fall time to $V_{OUT}$ (V-DAC coming out of power-down mode)		8		$\mu$ s

- (1) All input signals are specified with  $t_r = t_f \leq 2$ ns (10% to 90% of  $+V_{DV}$ ) and timed from a voltage level of  $(V_{IL} + V_{IH})/2$ .
- (2) Based on design simulation and characterization; not production tested.
- (3) Maximum SCLK frequency is 20MHz at  $+V_{AV} = +V_{DV} = +2.7V$  to 3.3V.

**V-DAC: SERIAL DATA INPUT FORMAT**

DB15	DB14	DB13	DB12	DB11	DB10	DB9	DB8	DB7	DB6	DB5	DB4	DB3	DB2	DB1	DB0
<b>A0</b>	<b>A1</b>	<b>A2</b>	<b>A3</b>	<b>D11</b>	<b>D10</b>	<b>D9</b>	<b>D8</b>	<b>D7</b>	<b>D6</b>	<b>D5</b>	<b>D4</b>	<b>D3</b>	<b>D2</b>	<b>D1</b>	<b>D0</b>
DAC1	DAC2	DAC3	DAC4	(MSB)											(LSB)
Address Bits				12-Bit Data Word											

NOTE: A logic high in the address bit will select the corresponding V-DAC and write the data word into its register. If more than one address bit is set high, the selected V-DACs are updated with the same data word simultaneously.

**PIN ASSIGNMENTS**

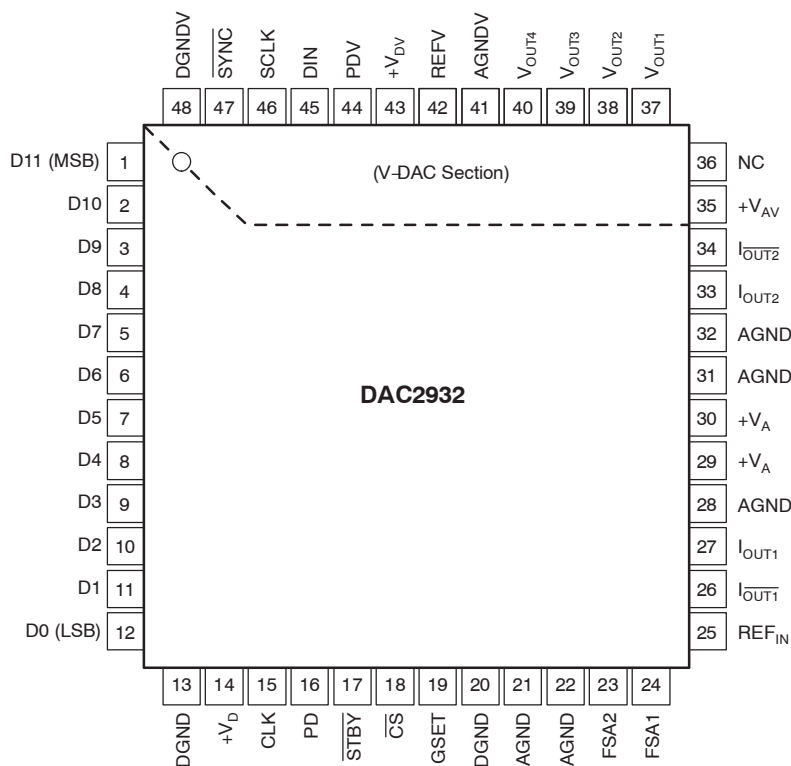

**Terminal Functions**

TERMINAL		I/O	DESCRIPTION
NAME	NO.		
D11:D0	1:12	I	Parallel data input port for the dual I-DACs; MSB = D11, LSB = D0; interleaved operation.
DGND	13		Digital ground of I-DAC
+V <sub>D</sub>	14		Digital supply of I-DAC; 2.7V to 3.3V
CLK	15	I	Clock input of I-DAC
PD	16	I	Power-down pin; active high; a logic high initiates power-down mode.
STBY	17	I	Standby pin of I-DAC; active low; a logic low initiates Standby mode with PD = Low. A logic high configures the I-DAC for normal operation; pin will resume a high state if left open.
CS	18	I	Chip select; active low; enables the parallel data port of the I-DACs; if used as chip select in applications using multiple DAC2932 devices, the parallel port data must be scrambled for proper functionality. Pin will resume a low state if left open.
GSET	19	I	Gain-setting mode. A logic high enables the use of two separate full-scale adjust resistors on pins FSA1 and FSA2. A logic low allows the use of a common full-scale adjust resistor connected to FSA1. The function of the FSA2 pin is disabled, and any remaining resistor has no effect. The value for the R <sub>SET</sub> resistor remains the same for a given full-scale range, regardless of the selected GSET mode. Pin will resume a low state if left open.
DGND	20		Digital ground of I-DAC
AGND	21		Analog ground of I-DAC
AGND	22		Analog ground of I-DAC
FSA2	23	I	Full-scale adjust of I-DAC2; connect external gain setting resistor R <sub>SET2</sub> = 19.6kΩ.
FSA1	24	I	Full-scale adjust of I-DAC1; connect external gain setting resistor R <sub>SET1</sub> = 19.6kΩ.



**Terminal Functions (continued)**

TERMINAL		I/O	DESCRIPTION
NAME	NO.		
REF <sub>IN</sub>	25	I	External reference voltage input; internal reference voltage output; bypass with 0.1μF to AGND for internal reference operation.
I <sub>OUT1</sub>	26	O	Complementary current output of I-DAC1
I <sub>OUT1</sub>	27	O	Current output of I-DAC1
AGND	28		Analog ground of I-DAC
+V <sub>A</sub>	29		Analog supply of I-DAC; 2.7V to 3.3V
+V <sub>A</sub>	30		Analog supply of I-DAC; 2.7V to 3.3V
AGND	31		Analog ground of I-DAC
AGND	32		Analog ground of I-DAC
I <sub>OUT2</sub>	33	O	Current output of I-DAC2
I <sub>OUT2</sub>	34	O	Complementary current output of I-DAC2
+V <sub>AV</sub>	35		Analog supply of V-DAC; 2.7V to 3.3V
NC	36		No internal connection
V <sub>OUT1</sub>	37	O	Voltage output of V-DAC1
V <sub>OUT2</sub>	38	O	Voltage output of V-DAC2
V <sub>OUT3</sub>	39	O	Voltage output of V-DAC3
V <sub>OUT4</sub>	40	O	Voltage output of V-DAC4
AGNDV	41		Analog ground of V-DAC
REFV	42	I	Reference voltage input for V-DACs; typically connected to supply (+V <sub>AV</sub> )
+V <sub>DV</sub>	43		Digital supply of V-DAC; 2.7V to 3.3V
PDV	44	I	Power-down of V-DACs; active high; a logic high initiates the power-down mode
DIN	45	I	Serial digital input for V-DAC; see timing and application sections for details
SCLK	46	I	Clock input of V-DAC
SYNC	47	I	Frame synchronization signal for the serial data at DIN. Refer to timing section for details.
DGNDV	48		Digital ground of V-DAC.

### TYPICAL CHARACTERISTICS

$T_A = +25^\circ\text{C}$ ,  $+V_A = +V_{AV} = +3\text{V}$ ,  $+V_D = +V_{DV} = +3\text{V}$ ,  $I_{OUTFS} = 2\text{mA}$ , differential transformer-coupled output ( $n = 4:1$ ),  $R_L = 400\Omega$  on I-DAC,  $R_L = 2\text{k}\Omega$  on V-DAC, and GSET = H unless otherwise noted.

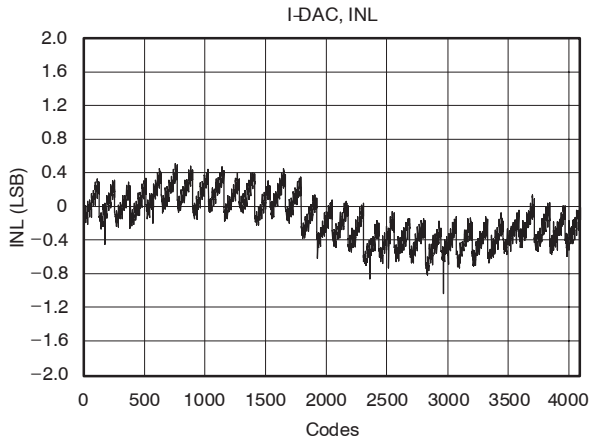

Figure 3

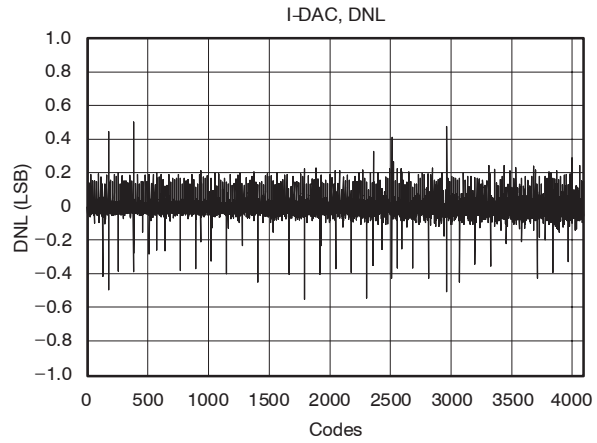

Figure 4

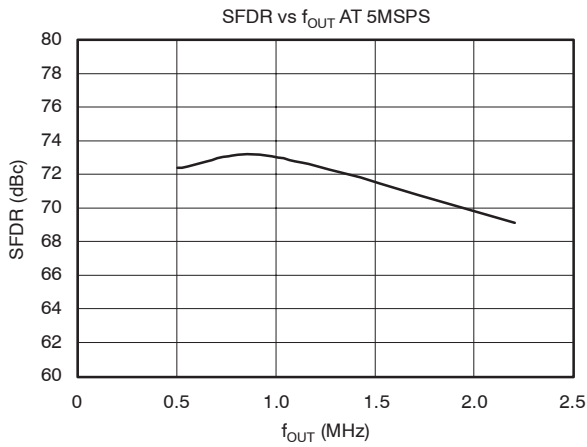

Figure 5

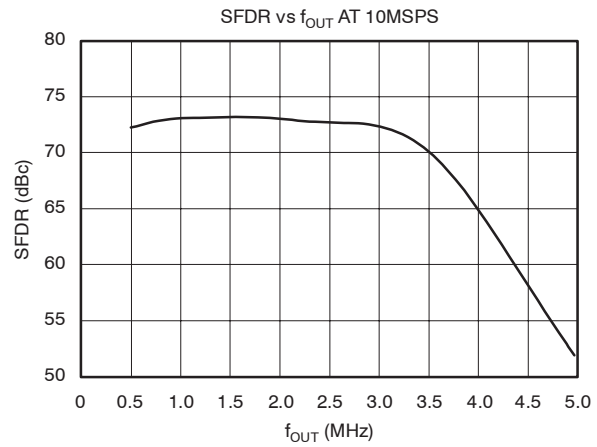

Figure 6

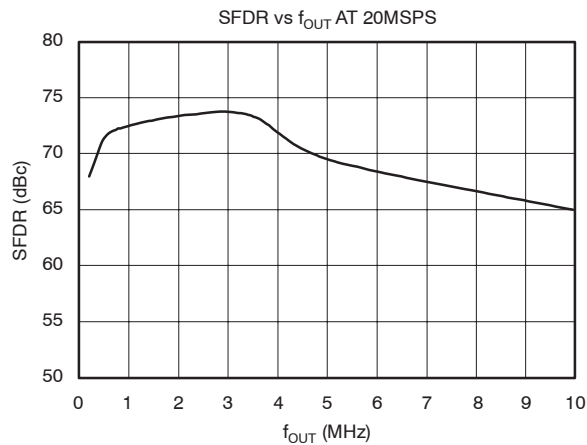

Figure 7

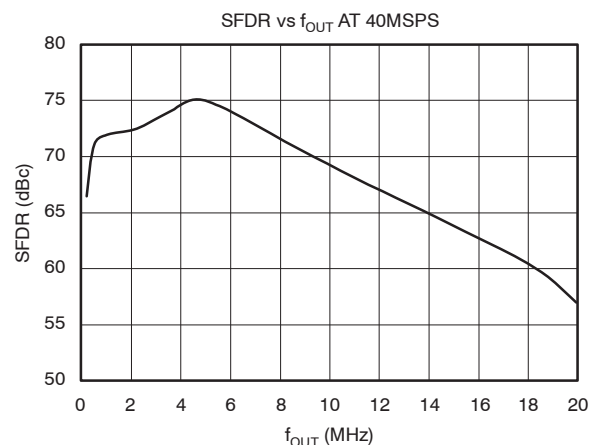
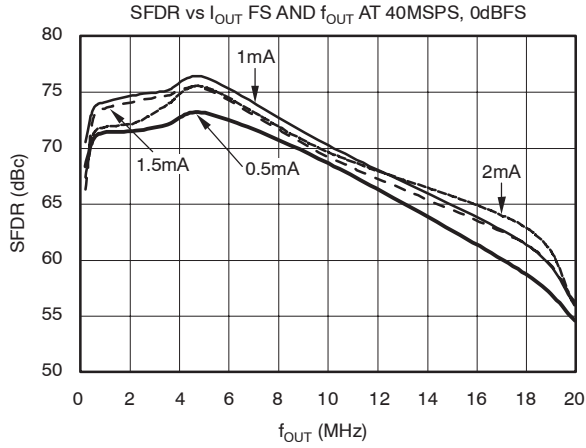

Figure 8

**TYPICAL CHARACTERISTICS (continued)**

$T_A = +25^\circ\text{C}$ ,  $+V_A = +V_{AV} = +3\text{V}$ ,  $+V_D = +V_{DV} = +3\text{V}$ ,  $I_{OUTFS} = 2\text{mA}$ , differential transformer-coupled output ( $n = 4:1$ ),  $R_L = 400\Omega$  on I-DAC,  $R_L = 2\text{k}\Omega$  on V-DAC, and GSET = H unless otherwise noted.



**Figure 9**

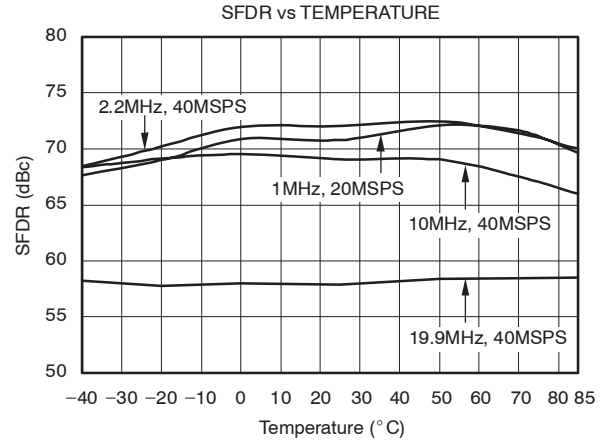

**Figure 10**

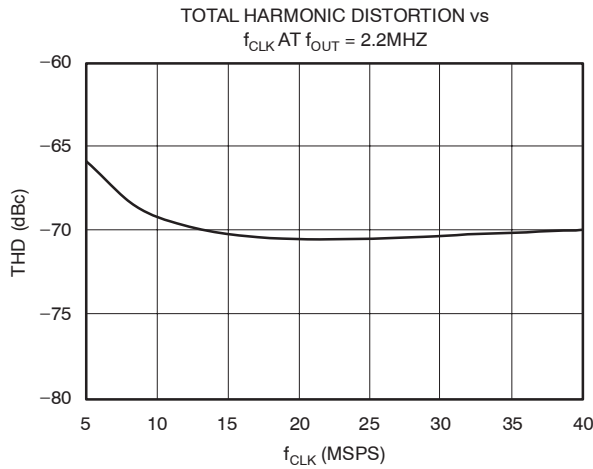

**Figure 11**

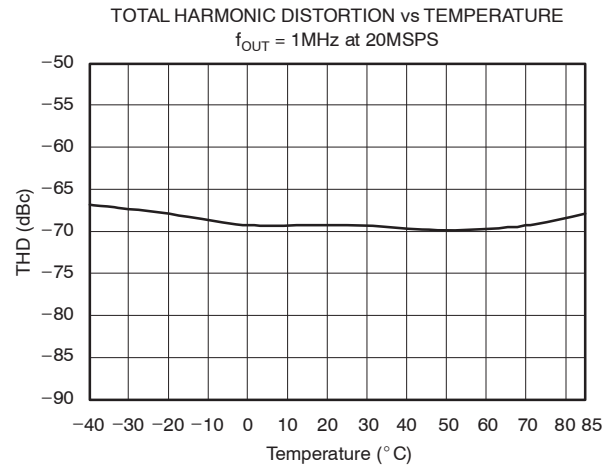

**Figure 12**

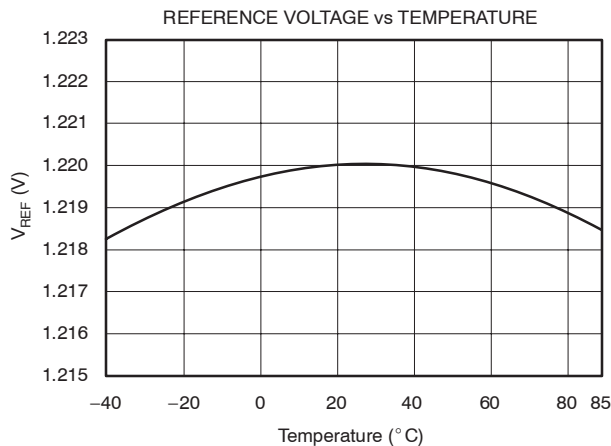

**Figure 13**

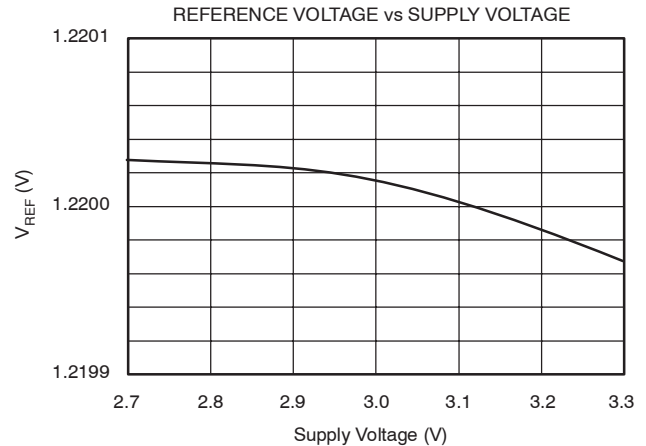

**Figure 14**

**TYPICAL CHARACTERISTICS (continued)**

$T_A = +25^\circ\text{C}$ ,  $+V_A = +V_{AV} = +3\text{V}$ ,  $+V_D = +V_{DV} = +3\text{V}$ ,  $I_{OUTFS} = 2\text{mA}$ , differential transformer-coupled output ( $n = 4:1$ ),  $R_L = 400\Omega$  on I-DAC,  $R_L = 2\text{k}\Omega$  on V-DAC, and GSET = H unless otherwise noted.

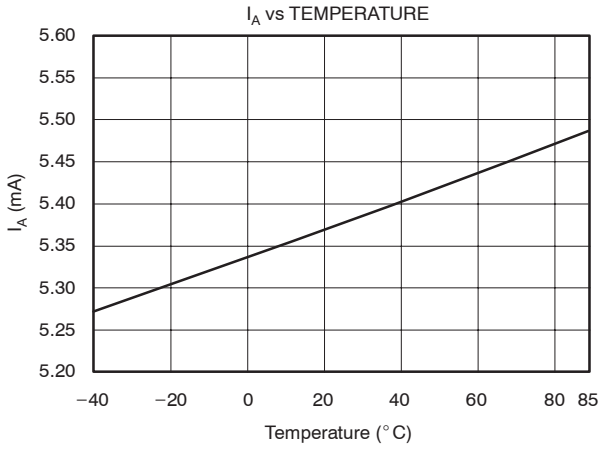

**Figure 15**

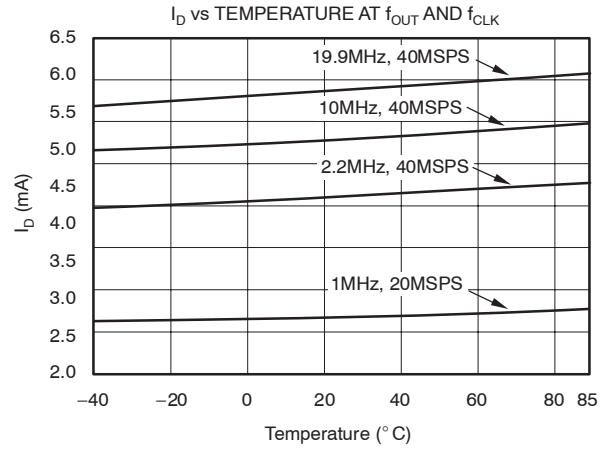

**Figure 16**

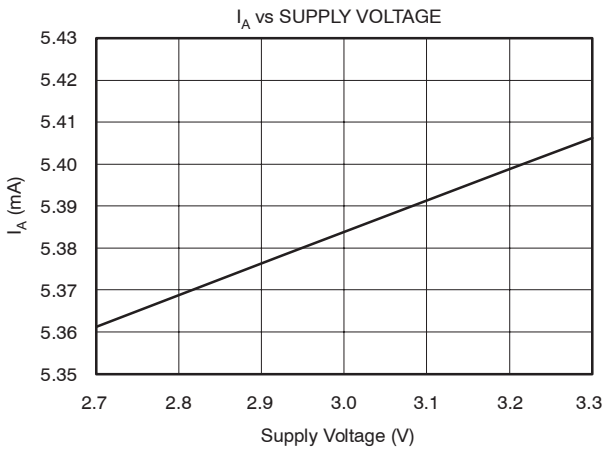

**Figure 17**

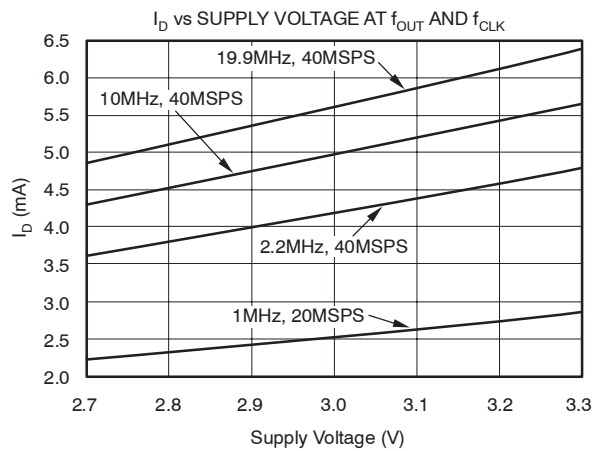

**Figure 18**

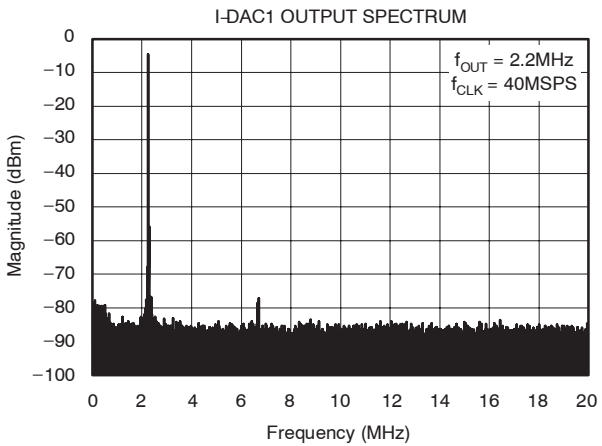

**Figure 19**

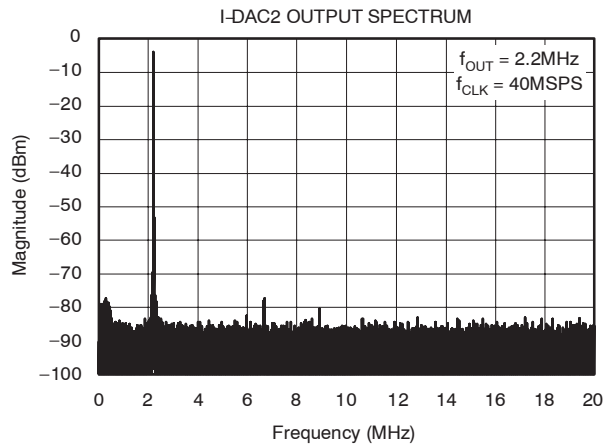

**Figure 20**

**TYPICAL CHARACTERISTICS (continued)**

$T_A = +25^\circ\text{C}$ ,  $+V_A = +V_{AV} = +3\text{V}$ ,  $+V_D = +V_{DV} = +3\text{V}$ ,  $I_{OUTFS} = 2\text{mA}$ , differential transformer-coupled output ( $n = 4:1$ ),  $R_L = 400\Omega$  on I-DAC,  $R_L = 2\text{k}\Omega$  on V-DAC, and GSET = H unless otherwise noted.

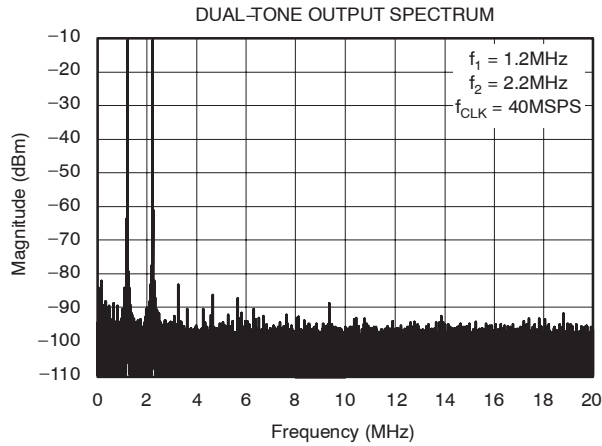

**Figure 21**

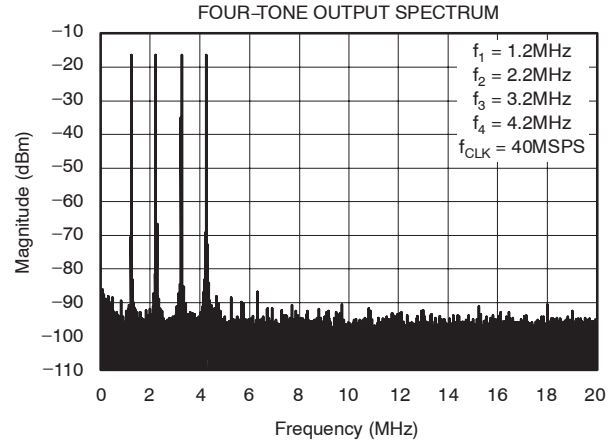

**Figure 22**

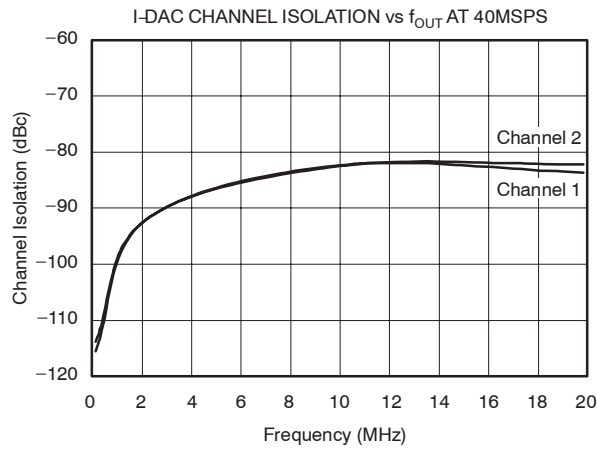

**Figure 23**

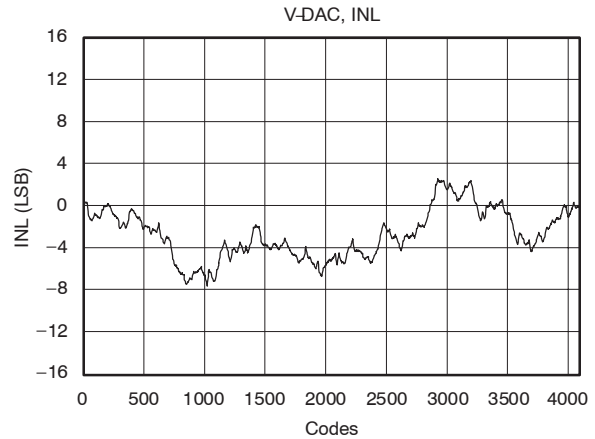

**Figure 24**

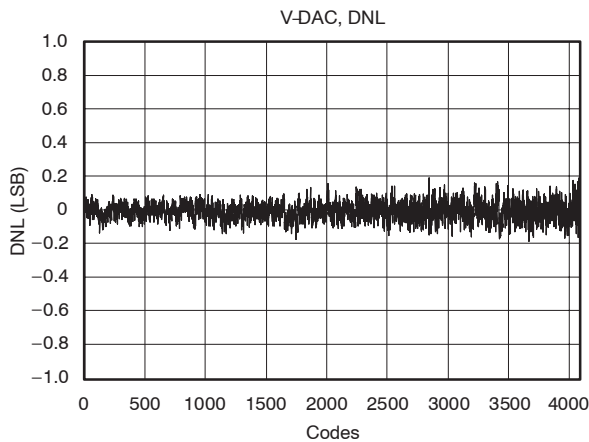

**Figure 25**

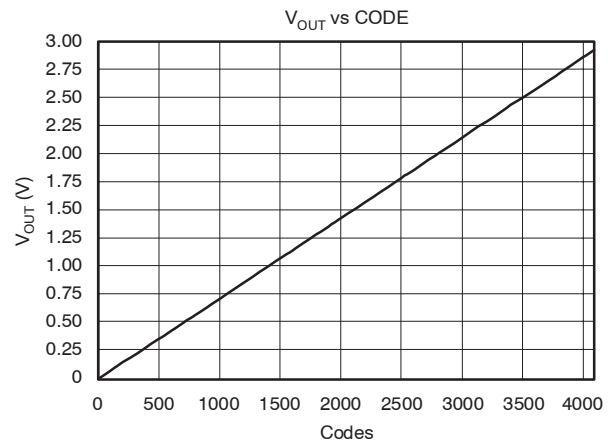

**Figure 26**

## APPLICATION INFORMATION

### THEORY OF OPERATION

The architecture of the DAC2932 uses the current steering technique to enable fast switching and a high update rate. The core element within the monolithic DAC is an array of segmented current sources that are designed to deliver a full-scale output current of up to 2mA, as shown in Figure 27. An internal decoder addresses the differential current switches each time the DAC is updated and a corresponding output current is formed by steering all currents to either output summing node,  $I_{OUT}$  or  $\overline{I_{OUT}}$ . The complementary outputs deliver a differential output signal, which improves the dynamic performance through reduction of even-order harmonics and common-mode signals (noise), and doubles the peak-to-peak output signal swing by a factor of two, compared to single-ended operation.

The segmented architecture results in a significant reduction of the glitch energy, and improves the dynamic performance (SFDR) and DNL. The current outputs maintain a very high output impedance of greater than 200k $\Omega$ .

The full-scale output current is determined by the ratio of the internal reference voltage (approximately +1.2V) and an external resistor,  $R_{SET}$ . The resulting  $I_{REF}$  is internally multiplied by a factor of 32 to produce an effective DAC output current that can range from 0.5mA to 2mA, depending on the value of  $R_{SET}$ .

The DAC2932 is split into a digital and an analog portion, each of which is powered through its own supply pin. The digital section includes edge-triggered input latches and the decoder logic, while the analog section comprises the current source array with its associated switches, and the reference circuitry.

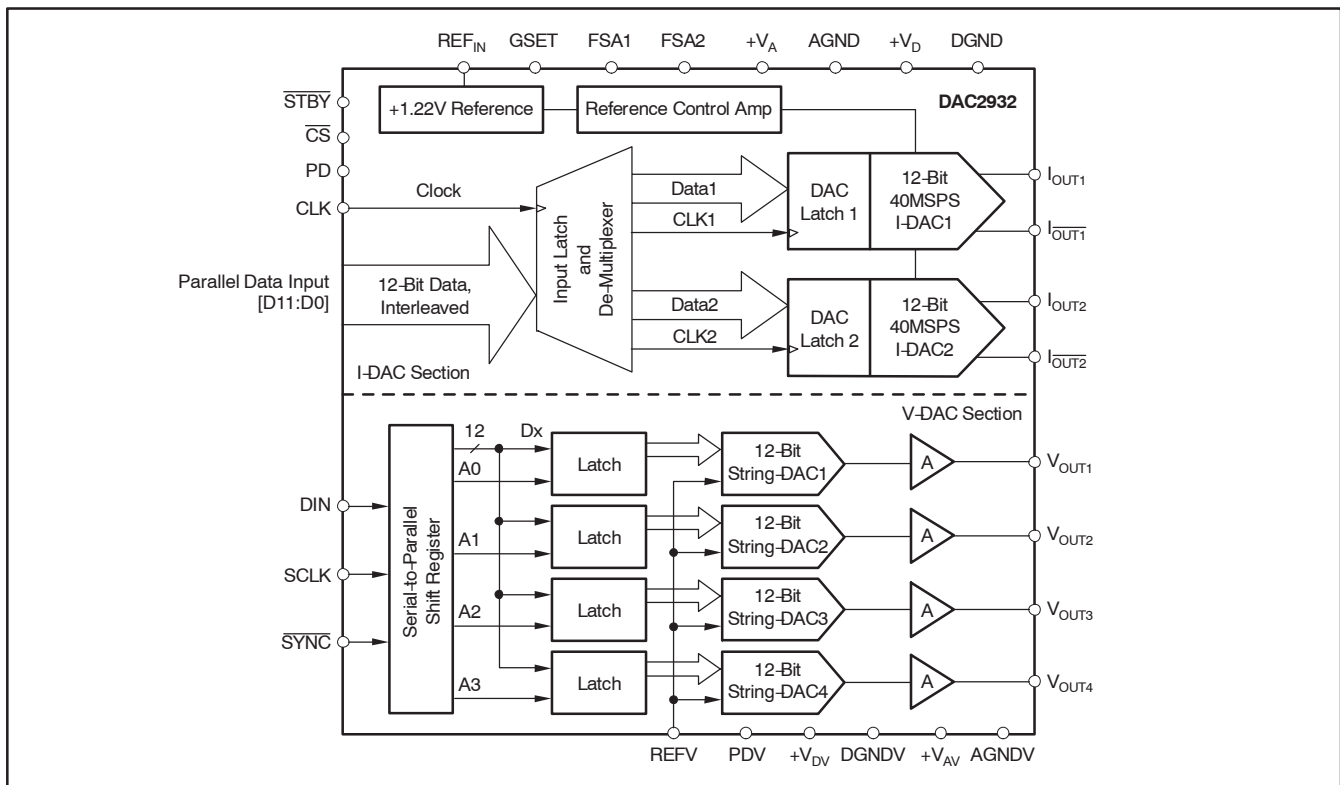

Figure 27. Block Diagram of the DAC2932

## DAC TRANSFER FUNCTION

Each of the I-DACs in the DAC2932 has a complementary current output,  $I_{OUT1}$  and  $I_{OUT2}$ . The full-scale output current,  $I_{OUTFS}$ , is the summation of the two complementary output currents:

$$I_{OUTFS} = I_{OUT} + I_{\overline{OUT}} \quad (1)$$

The individual output currents depend on the DAC code and can be expressed as:

$$I_{OUT} = I_{OUTFS} \times (\text{Code}/4096) \quad (2)$$

$$I_{\overline{OUT}} = I_{OUTFS} \times (4095 - \text{Code})/4096 \quad (3)$$

where Code is the decimal representation of the DAC data input word (0 to 4095).

Additionally,  $I_{OUTFS}$  is a function of the reference current  $I_{REF}$ , which is determined by the reference voltage and the external setting resistor,  $R_{SET}$ .

$$I_{OUTFS} = 32 \times I_{REF} = 32 \times \frac{V_{REF}}{R_{SET}} \quad (4)$$

In most cases, the complementary outputs will drive resistive loads or a terminated transformer. A signal voltage will develop at each output according to:

$$V_{OUT} = I_{OUT} \times R_{LOAD} \quad (5)$$

$$V_{\overline{OUT}} = I_{\overline{OUT}} \times R_{LOAD} \quad (6)$$

The value of the load resistance is limited by the output compliance specification of the DAC2932. To maintain optimum linearity performance, the compliance voltage at  $I_{OUT}$  and  $I_{\overline{OUT}}$  should be limited to +0.5V or less.

The two single-ended output voltages can be combined to find the total differential output swing:

$$\begin{aligned} V_{OUTDIFF} &= V_{OUT} - V_{\overline{OUT}} \\ &= \frac{(2 \times \text{Code} - 4095)}{4096} \times I_{OUTFS} \times R_{LOAD} \end{aligned} \quad (7)$$

## POWER-DOWN MODES

The DAC2932 has several modes of operation. Besides normal operation, the I-DAC section features a Standby mode and a full power-down mode, while the V-DAC section has one power-down mode. All modes are controlled by appropriate logic levels on the assigned pins of the DAC2932. Table 1 lists all pins and possible modes. The pins have internal pull-ups or pull-downs; if left open, all pins will resume logic levels that place the I-DAC and V-DAC in a normal operating mode (fully functional).

When in Standby mode the analog functions of the I-DAC section are powered down. The internal logic is still active and will consume some power if the clock remains applied. To further reduce the power in Standby mode the  $\overline{CS}$  pin may be pulled high, which disables the internal logic from being clocked, even with the clock signal applied.

If  $\overline{CS}$  remains low during the Standby mode and a running clock remains applied, any new data on the parallel data port will be latched into the DAC. The analog output, however, will not be updated as long as the I-DACs remain in Standby mode.

**Table 1. Power-Down Modes**

PD (16)	STBY(17)	CS (18)	PDV (44)	DAC	MODE	DAC OUTPUTS
0	0	0	X	I-DAC enabled	Standby; data can still be written into the DACs with running clock applied	High-Z
0	0	1	X	I-DAC disabled	Standby; writing into DAC disabled—clock input disabled by $\overline{CS}$	High-Z
0	1	0	X	I-DAC enabled	Normal operation (return from Standby)	Last state prior to Standby
0	1	1	X	I-DAC disabled	Data input and clock input disabled; use when multiple devices on one bus	Last data held
1	X	X	X	I-DAC disabled	Full power-down; STBY and CS have no effect	High-Z
0	X	X	0	V-DAC enabled	V-DAC normal operation	
X	X	X	1	V-DAC disabled	V-DAC in power-down mode; independent operation of any I-DAC power-down configuration	All outputs; High-Z

NOTE: X = don't care.

**CHIP SELECT OPERATION**

The I-DAC clock is controlled by PD and  $\overline{CS}$  through a digital clock interface that generates an internal clock which controls the data latches. Under normal operation PD and  $\overline{CS}$  are kept low and the internal clock is just a delayed version of the clock signal present at the CLK pin. The data for channel 1 and channel 2 are latched by the rising and falling edges of CLK, respectively. The rising edge of CLK also causes the DAC to output the previously latched data pair.

The  $\overline{CS}$  pin can be used to synchronize the latching of data from a single data bus connected to multiple DAC2932 devices, however in order for this operation to work correctly the data pairs on the bus have to be scrambled so that they are arranged correctly at the DAC outputs. The reason for this is explained in the following:

Figure 28 shows a timing diagram of the  $\overline{CS}$  operation. When the  $\overline{CS}$  pin is pulled high, the data in the parallel input port is not latched. The high condition on the  $\overline{CS}$  pin is latched into the clock interface on the first rising edge of CLK following the  $\overline{CS}$  edge; this holds the internal clock in

a high condition, ignoring the CLK edges and thus not latching the bus data. In order to enable data latching, the  $\overline{CS}$  pin must be returned to a low state. The change of state in  $\overline{CS}$  is latched into the clock interface on the first rising CLK edge; this enables the internal clock which causes the data in channel 2 to be latched on the first falling edge of CLK. The next rising edge of CLK causes the DAC to output the old data from channel 1 and the new data just latched into channel 2 as well as to latch the new data into channel 1.

The operation previously described causes problems in those situations that have two or more DAC2932 devices sharing the same data bus with each DAC2932 reading every nth data pair. The (channel1, channel2) data pairs appearing at the DAC output correspond to (channel1 from the previous read cycle, channel2 data from the current read cycle) pairs. In order for the data bus pairs to be output correctly it is necessary to scramble the (channel1, channel2) data pairs so that the bus data corresponds to . . . , channel1, data for other DACs, channel2, . . . for each DAC2932.

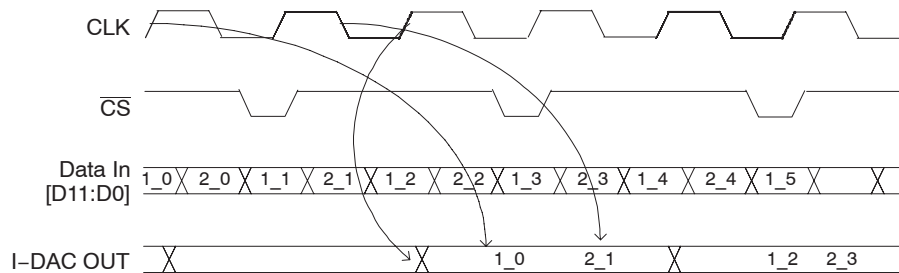
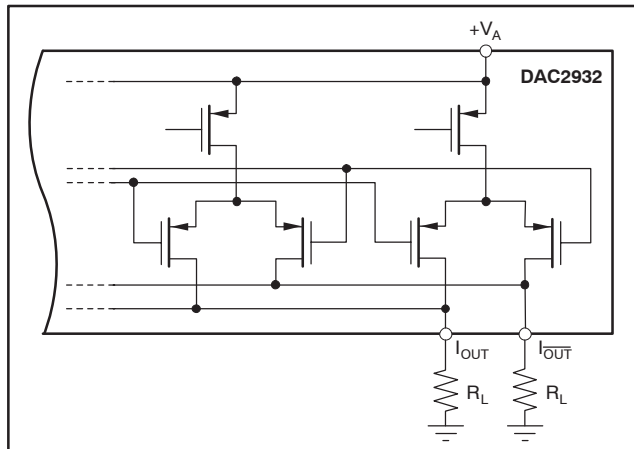

**Figure 28. Timing Diagram of the  $\overline{CS}$  Pin**



## ANALOG OUTPUTS

The DAC2932 provides two sets of complementary current outputs,  $I_{OUT}$  and  $\overline{I_{OUT}}$ . The simplified circuit of the analog output stage representing the differential topology is shown in Figure 29. The output impedance of  $I_{OUT}$  and  $\overline{I_{OUT}}$  results from the parallel combination of the differential switches, along with the current sources and associated parasitic capacitances.



**Figure 29. Equivalent Analog Output**

The signal voltage swing that develops at the two outputs,  $I_{OUT}$  and  $\overline{I_{OUT}}$ , is limited by a negative and positive compliance. The negative limit of  $-0.5V$  is given by the breakdown voltage of the CMOS process, and exceeding it will compromise the reliability of the DAC2932, or even cause permanent damage. With the full-scale output set to 2mA, the positive compliance equals 0.8V, operating with an analog supply of  $+V_A = 3V$ . To avoid degradation of the distortion performance and integral linearity, care must be taken so that the configuration of the DAC2932 does not exceed the compliance range.

Best distortion performance is typically achieved with the maximum full-scale output signal limited to approximately  $0.5V_{PP}$ . This is the case for a  $250\Omega$  load and a 2mA full-scale output current. A variety of loads can be adapted to the output of the DAC2932 by selecting a suitable transformer while maintaining optimum voltage levels at  $I_{OUT}$  and  $\overline{I_{OUT}}$ . Furthermore, using the differential output configuration in combination with a transformer is instrumental in achieving excellent distortion performance. Common-mode errors, such as even-order harmonics or noise, can be substantially reduced. This is particularly the case with high output frequencies.

For those applications requiring the optimum distortion and noise performance, it is recommended to select a full-scale output of 2mA. A lower full-scale range down to

0.5mA may be considered for applications that require low power consumption, but can tolerate a slightly reduced performance level.

The current-output DACs of the DAC2932 have a straight offset binary coding format. With all bits high, the full-scale output current (for example, 2mA) will be sourced at pins  $I_{OUT1}$  and  $I_{OUT2}$ , as shown in Table 2.

**Table 2. Input Coding vs Analog Output Current**

INPUT CODE (D11–D0)	$I_{OUT}$ (mA)	$\overline{I_{OUT}}$ (mA)
1111 1111 1111	2	0
1000 0000 0000	1	1
0000 0000 0000	0	2

## OUTPUT CONFIGURATIONS

As mentioned previously, utilizing the differential outputs of the converter yields the best dynamic performance. Such a differential output circuit may consist of an RF transformer or a differential amplifier configuration. The transformer configuration is ideal for most applications with ac coupling, while op amps are suitable for a dc-coupled configuration.

The single-ended configuration may be considered for applications requiring a unipolar output voltage. Connecting a resistor from either one of the outputs to ground converts the output current into a ground-referenced voltage signal. To improve on the dc linearity by maintaining a virtual ground, an I-to-V or op-amp configuration may be considered.

## DIFFERENTIAL WITH TRANSFORMER

Using an RF transformer provides a convenient way of converting the differential output signal into a single-ended signal while achieving excellent dynamic performance (see Figure 3). The appropriate transformer should be carefully selected based on the output frequency spectrum and impedance requirements. The differential transformer configuration has the benefit of significantly reducing common-mode signals, thus improving the dynamic performance over a wide range of frequencies. Furthermore, by selecting a suitable impedance ratio (winding ratio), the transformer can be used to provide optimum impedance matching while controlling the compliance voltage for the converter outputs. The model shown, ADT16-6T (by Mini-Circuits), has a 16:1 ratio and may be used to interface the DAC2932 to a  $50\Omega$  load. This results in a  $200\Omega$  load for each of the outputs,  $I_{OUT}$  and  $\overline{I_{OUT}}$ . The output signals are ac coupled and inherently isolated by the transformer.

As shown in Figure 30, the transformer center tap is connected to ground. This forces the voltage swing on  $I_{OUT}$  and  $\overline{I_{OUT}}$  to be centered at 0V. In this case the two resistors,  $R_L$ , may be replaced with one,  $R_{DIFF}$ , or omitted altogether. Alternatively, if the center tap is not connected, the signal swing will be centered at  $R_L \times I_{OUTFS}/2$ . However, in this case, the two resistors ( $R_L$ ) must be used to enable the necessary dc-current flow for both outputs.

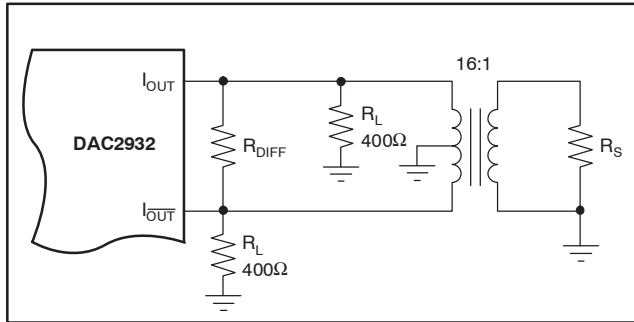

**Figure 30. Differential Output Configuration Using an RF Transformer**

**DIFFERENTIAL CONFIGURATION USING AN OP AMP**

If the application requires a dc-coupled output, a difference amplifier may be considered, as shown in Figure 31. Four external resistors are needed to configure the OPA690 voltage-feedback op amp as a difference amplifier performing the differential to single-ended conversion. Under the configuration shown, the DAC2932 generates a differential output signal of 0.5V<sub>PP</sub> at the load resistors,  $R_L$ .

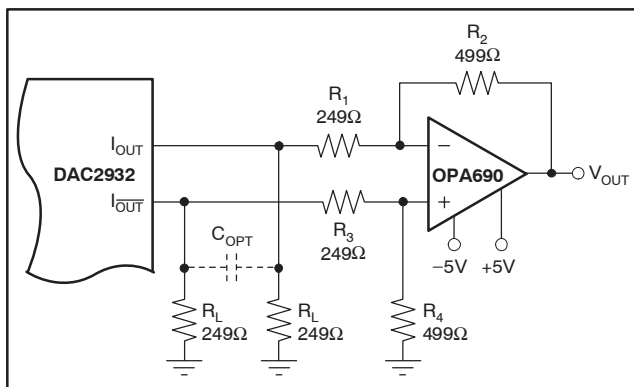

**Figure 31. Difference Amplifier Provides Differential-to-Single-Ended Conversion and DC-Coupling**

The OPA690 is configured for a gain of two. Therefore, operating the DAC2932 with a 2mA full-scale output produces a voltage output of  $\pm 1V$ . This requires the amplifier to operate from a dual power supply ( $\pm 5V$ ). The tolerance of the resistors typically sets the limit for the achievable common-mode rejection. An improvement can be obtained by fine tuning resistor  $R_4$ .

This configuration typically delivers a lower level of ac performance than the previously discussed transformer solution because the amplifier introduces another source of distortion. Suitable amplifiers should be selected based on their slew-rate, harmonic distortion, and output swing capabilities. A high-speed amplifier like the OPA690 may be considered. The ac performance of this circuit can be improved by adding a small capacitor ( $C_{DIFF}$ ) between the outputs  $I_{OUT}$  and  $\overline{I_{OUT}}$ , as shown in Figure 31. This will introduce a real pole to create a low-pass filter in order to slew-limit the fast output signal steps of the DAC, which otherwise could drive the amplifier into slew-limitations or into an overload condition; both would cause excessive distortion. The difference amplifier can easily be modified to add a level shift for applications requiring the single-ended output voltage to be unipolar (that is, swing between 0V and +2V).

**DUAL TRANSIMPEDANCE OUTPUT CONFIGURATION**

The circuit example of Figure 32 shows the signal output currents connected into the summing junctions of the OPA2690 dual voltage-feedback op amp, which is set up as a transimpedance stage or I-to-V converter. With this circuit, the DAC output will be kept at a virtual ground, minimizing the effects of output impedance variations, which results in the best dc linearity (INL). As mentioned previously, care should be taken not to drive the amplifier into slew-rate limitations and produce unwanted distortion.

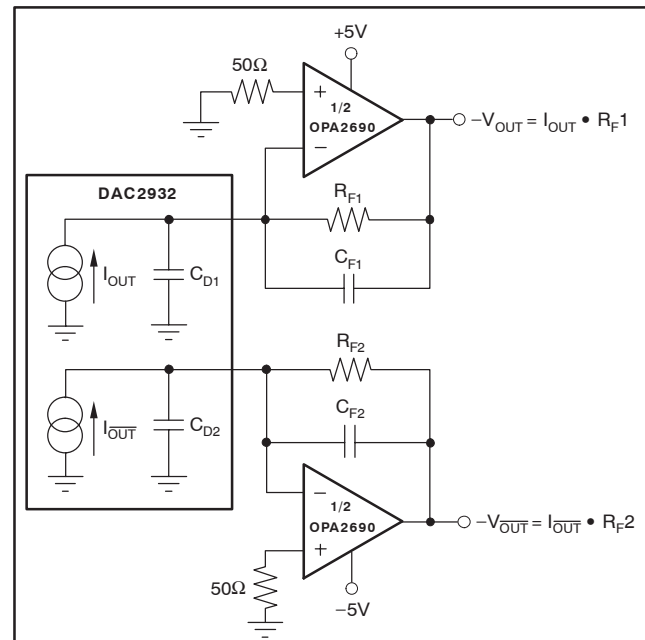

**Figure 32. The OPA2690 Dual, Voltage-Feedback Amplifier Forms a Transimpedance Amplifier**

The DC gain for this circuit is equal to feedback resistor  $R_F$ . At high frequencies, the DAC output impedance ( $C_{D1}$ ,  $C_{D2}$ ) produces a zero in the noise gain for the OPA2690 that can cause peaking in the closed-loop frequency response.  $C_F$  is added across  $R_F$  to compensate for this noise gain peaking. To achieve a flat transimpedance frequency response, the pole in each feedback network should be set to:

$$\frac{1}{2\pi R_F C_F} = \frac{\sqrt{GBP}}{4\pi R_F C_F} \quad (8)$$

where  $GBP$  = gain bandwidth product of the op amp, which gives a corner frequency  $f_{-3dB}$  of approximately:

$$f_{-3dB} = \frac{\sqrt{GBP}}{2\pi R_F C_D} \quad (9)$$

The full-scale output voltage is simply defined by the product of  $I_{OUTFS} \cdot R_F$ , and has a negative unipolar excursion. To improve on the ac performance of this circuit, adjustment of  $R_F$  and/or  $I_{OUTFS}$  should be considered. Further extensions of this application example may include adding a differential filter at the OPA2690 output followed by a transformer, in order to convert to a single-ended signal.

### SINGLE-ENDED CONFIGURATION

Using a single load resistor connected to one of the DAC outputs, a simple current-to-voltage conversion can be accomplished. The circuit in Figure 33 shows a 250Ω resistor connected to  $I_{OUT}$ . Therefore, with a nominal output current of 2mA, the DAC produces a total signal swing of 0V to 0.5V.

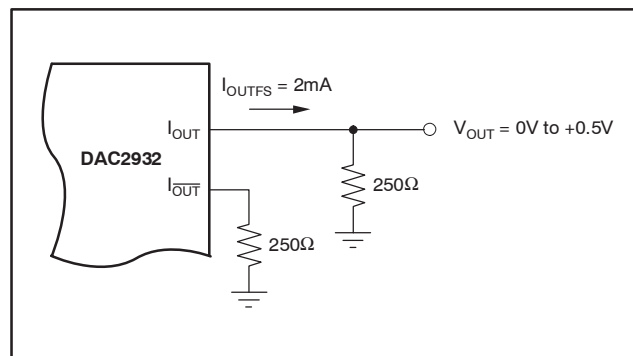
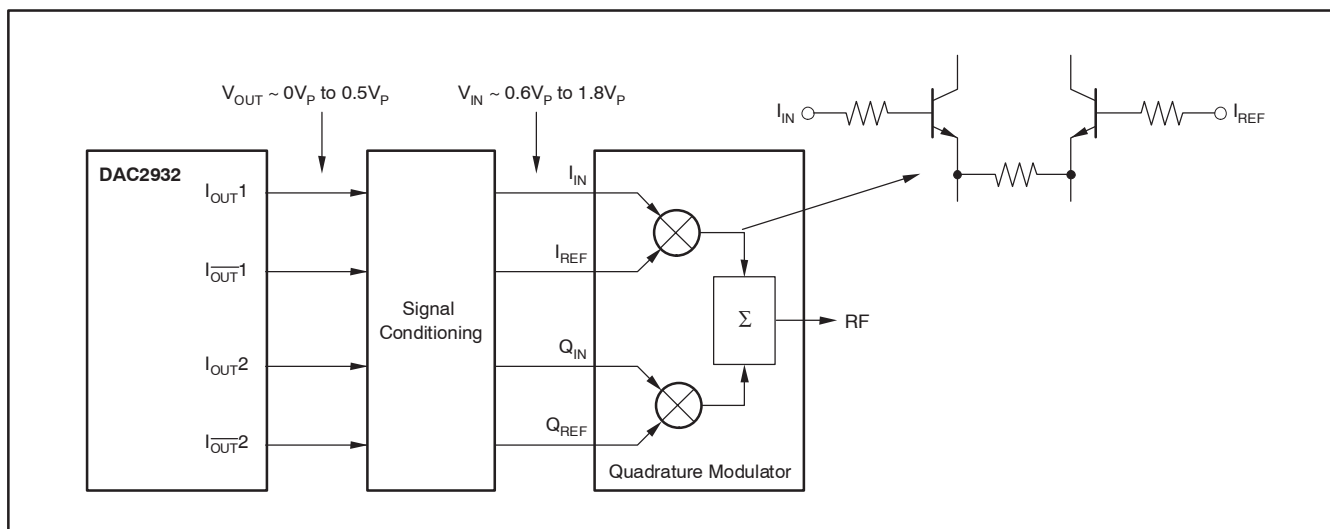

**Figure 33. Differential Output Configuration Using an RF Transformer**

Different load resistor values may be selected, as long as the output compliance range is not exceeded. Additionally, the output current ( $I_{OUTFS}$ ) and the load resistor can be mutually adjusted to provide the desired output signal swing and performance.

### INTERFACING ANALOG QUADRATURE MODULATORS

One of the main applications for the dual-channel DAC is baseband I- and Q-channel transmission for digital communications. In this application, the DAC is followed by an analog quadrature modulator, modulating an IF carrier with the baseband data, as shown in Figure 34. Often, the input stages of these quadrature modulators consist of npn-type transistors that require a dc bias (base) voltage of  $> 0.8V$ .



**Figure 34. Generic Interface to a Quadrature Modulator. Signal conditioning (level shifting) may be required to ensure correct dc common-mode levels at the input of the quadrature modulator.**

Figure 35 shows an example of a dc-coupled interface with dc level-shifting, using a precision resistor network. An ac-coupled interface, as shown in Figure 36, has the advantage in that the common-mode levels at the input of the modulator can be set independently of those at the output of the DAC. Furthermore, no voltage loss occurs in this setup.

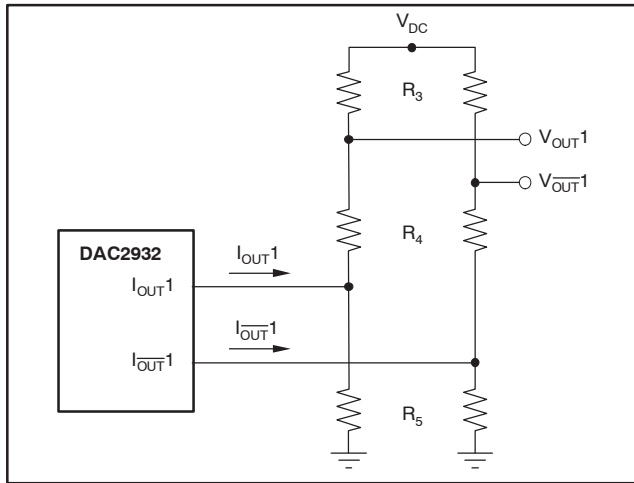

Figure 35. DC-Coupled Interface to a Quadrature Modulator Applying Level Shifting

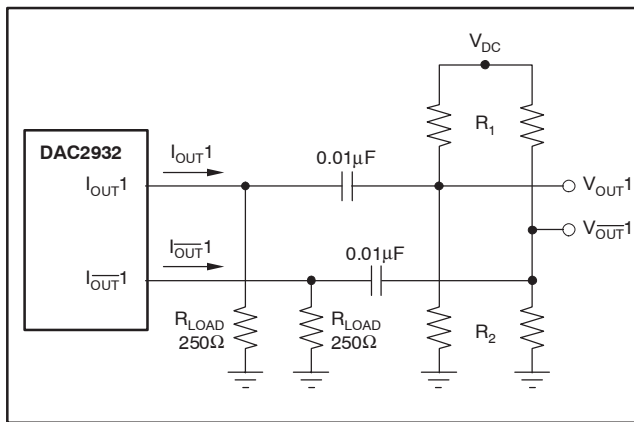

Figure 36. AC-Coupled Interface to a Quadrature Modulator Applying Level Shifting

### INTERNAL REFERENCE OPERATION

The DAC2932 has an on-chip reference circuit that comprises a 1.22V bandgap reference and two control amplifiers, one for each DAC. The full-scale output current,  $I_{OUTFS}$ , of the DAC2932 is determined by the reference voltage,  $V_{REF}$ , and the value of resistor  $R_{SET}$ .  $I_{OUTFS}$  can be calculated by:

$$I_{OUTFS} = 32 \times I_{REF} = 32 \times \frac{V_{REF}}{R_{SET}} \quad (10)$$

The external resistor  $R_{SET}$  connects to the FSA pin (full-scale adjust) as shown in Figure 37. The reference control amplifier operates as a V-to-I converter producing a reference current,  $I_{REF}$ , which is determined by the ratio of  $V_{REF}$  and  $R_{SET}$ , as shown in Equation 10. The full-scale output current,  $I_{OUTFS}$ , results from multiplying  $I_{REF}$  by a fixed factor of 32.

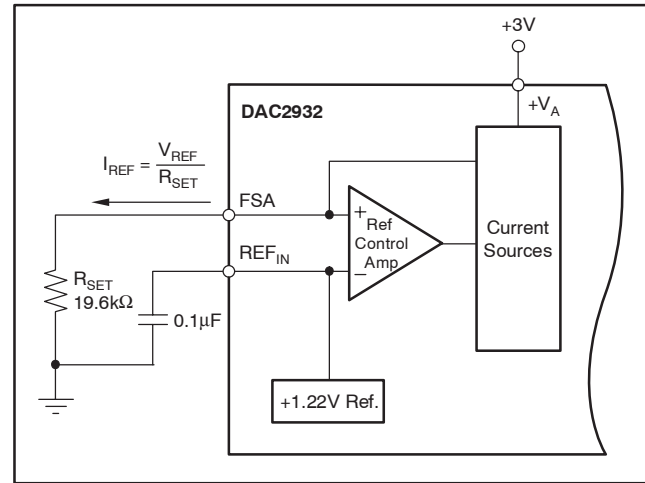

Figure 37. Internal Reference Configuration

Using the internal reference, a 19.6kΩ resistor value results in a full-scale output of approximately 2mA. Resistors with a tolerance of 1% or better should be considered. Selecting higher values, the output current can be adjusted from 2mA down to 0.5mA. Operating the DAC2932 at lower than 2mA output currents may be desirable for reasons of reducing the total power consumption or observing the output compliance voltage limitations for a given load condition.

It is recommended to bypass the  $REF_{IN}$  pin with a ceramic chip capacitor of 0.1μF or more. The control amplifier is internally compensated, and its small signal bandwidth is approximately 0.1MHz.

### GAIN SETTING OPTIONS

The full-scale output current on the DAC2932 can be set two ways: either for each of the two DAC channels independently or for both channels simultaneously. For the independent gain set mode, GSET (pin 19) must be high (that is, connected to  $+V_A$ ). In this mode, two external resistors are required—one  $R_{SET}$  connected to the FSA1 pin (pin 24) and the other to the FSA2 pin (pin 23). In this configuration, the user has the flexibility to set and adjust the full-scale output current for each DAC independently, allowing for the compensation of possible gain mismatches elsewhere within the transmit signal path.

Alternatively, bringing GSET low (that is, connected to AGND), switches the DAC2932 into the simultaneous gain set mode. Now the full-scale output current of both DAC channels is determined by only one external  $R_{SET}$  resistor connected to the FSA1 pin. The resistor at the FSA2 pin may be removed; however, this is not required since this pin is not functional in this mode and the resistor has no effect on the gain equation. The formula for deriving the correct  $R_{SET}$  remains unchanged. For example,  $R_{SET} = 19.6k\Omega$  will result in a 2mA output for both DACs. The DAC2932 is specified with GSET being high and operating in independent gain mode. It should be noted that when using the simultaneous gain mode, the gain error and gain matching error will increase.

### EXTERNAL REFERENCE OPERATION

The internal reference can be disabled by simply applying an external reference voltage into the  $REF_{IN}$  pin, which in this case functions as an input, as shown in Figure 38. The use of an external reference may be considered for applications that require higher accuracy and drift performance.

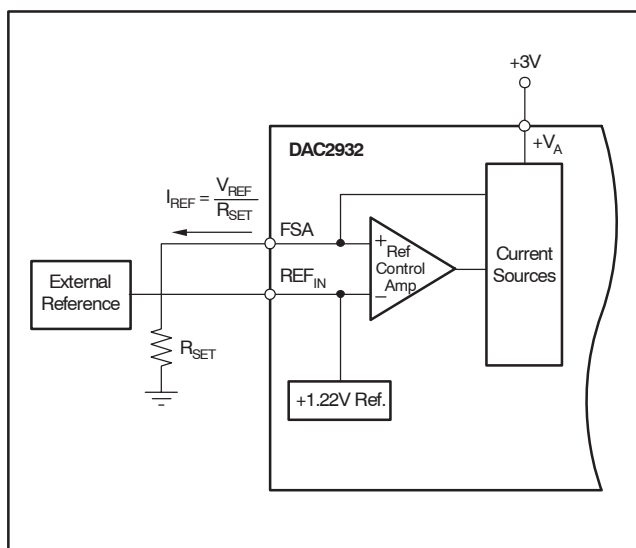
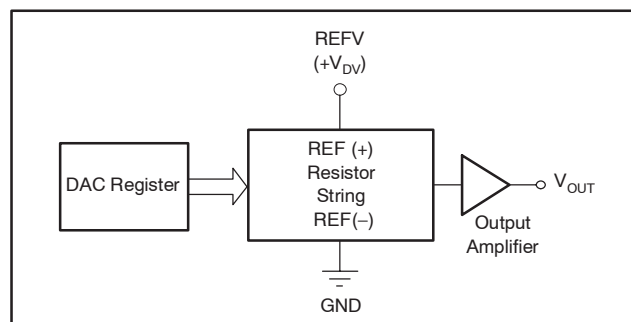

**Figure 38. External Reference Configuration**

While a 0.1 $\mu$ F capacitor is recommended for use with the internal reference, it is optional for the external reference operation. The reference input,  $REF_{IN}$ , has a high input impedance and can easily be driven by various sources.

### V-DAC

The architecture consists of a resistor string DAC followed by an output buffer amplifier. Figure 39 shows a block diagram of the DAC architecture.



**Figure 39. V-DAC Architecture**

The input coding to the V-DAC is straight binary, so the ideal output voltage is given by:

$$V_{OUT} = REFV \times \frac{D}{4096} \quad (11)$$

where D = decimal equivalent of the binary code that is loaded to the DAC register; it can range from 0 to 4095.

### SERIAL INTERFACE

The V-DACs have a three-wire serial interface ( $\overline{SYNC}$ , SCLK, and DIN), which is compatible with SPI, QSPI, and Microwire interface standards as well as most Digital Signal Processors (DSPs).

The write sequence begins by bringing the  $\overline{SYNC}$  line low. Data from the DIN line is clocked into the 16-bit shift register on the falling edge of SCLK. The serial clock frequency can be as high as 20MHz, making the V-DACs compatible with high-speed DSPs. On the 16th falling edge of the serial clock, the last data bit is clocked in and the programmed function is executed (that is, a change in DAC register contents and/or a change in the mode of operation).

At this point, the  $\overline{SYNC}$  line may be kept low or brought high. In either case, it must be brought high for a minimum of 50ns before the next write sequence so that a falling edge of  $\overline{SYNC}$  can initiate the next write sequence. Since the  $\overline{SYNC}$  buffer draws more current when the  $\overline{SYNC}$  signal is high than it does when it is low,  $\overline{SYNC}$  should be idled low between write sequences for lowest power operation of the part. As mentioned above, however, it must be brought high again just before the next write sequence.

## INPUT SHIFT REGISTER

The input shift register is 16 bits wide. The first four bits are the address bits to the four V-DACs. The next 12 bits are the data bits. These are transferred to the DAC register on the 16th falling edge of the clock (SCLK).

## SYNC INTERRUPT

In a normal write sequence, the  $\overline{\text{SYNC}}$  line is kept low for at least 16 falling edges of SCLK and the DAC is updated on the 16th falling edge. However, if  $\overline{\text{SYNC}}$  is brought high before the 16th falling edge, this acts as an interrupt to the write sequence. The shift register is reset and the write sequence is seen as invalid. Neither an update of the DAC register contents nor a change in the operating mode occurs, as shown in Figure 40.

## POWER-ON RESET

The V-DACs contain a power-on reset circuit that controls the output voltage during power-up. On power-up, the DAC register is filled with zeros and the output voltage is 0V; it remains there until a valid write sequence is made to the DAC. This is useful in applications where it is important to know the state of the output of the DAC while it is in the process of powering up.

## GROUNDING, DECOUPLING, AND LAYOUT INFORMATION

Proper grounding and bypassing, short lead length, and the use of ground planes are particularly important for high-frequency designs. Multilayer printed circuit boards (PCBs) are recommended for best performance since they offer distinct advantages such as minimization of ground impedance, separation of signal layers by ground layers, etc.

The DAC2932 uses separate pins for its analog and digital supply and ground connections. The placement of the decoupling capacitor should be such that the analog supply ( $+V_A$ ) is bypassed to the analog ground (AGND), and the digital supply bypassed to the digital ground (DGND). In most cases, 0.1 $\mu\text{F}$  ceramic chip capacitors at

each supply pin are adequate to provide a low impedance decoupling path. Keep in mind that their effectiveness largely depends on the proximity to the individual supply and ground pins. Therefore, they should be located as close as physically possible to those device leads. Whenever possible, the capacitors should be located immediately under each pair of supply/ground pins on the reverse side of the PCB. This layout approach minimizes the parasitic inductance of component leads and PCB runs.

Further supply decoupling with surface-mount tantalum capacitors (1 $\mu\text{F}$  to 4.7 $\mu\text{F}$ ) can be added as needed in proximity of the converter.

Low noise is required for all supply and ground connections to the DAC2932. It is recommended to use a multilayer PCB with separate power and ground planes. Mixed signal designs require particular attention to the routing of the different supply currents and signal traces. Generally, analog supply and ground planes should only extend into analog signal areas, such as the DAC output signal and the reference signal. Digital supply and ground planes must be confined to areas covering digital circuitry, including the digital input lines connecting to the converter, as well as the clock signal. The analog and digital ground planes should be joined together at one point underneath the DAC. This can be realized with a short track of approximately 1/8" (3mm).

The power to the DAC2932 should be provided through the use of wide PCB runs or planes. Wide runs present a lower trace impedance, further optimizing the supply decoupling. The analog and digital supplies for the converter should only be connected together at the supply connector of the PCB. In the case of only one supply voltage being available to power the DAC, ferrite beads along with bypass capacitors can be used to create an LC filter. This will generate a low-noise analog supply voltage that can then be connected to the  $+V_A$  supply pin of the DAC2932.

While designing the layout, it is important to keep the analog signal traces separated from any digital line, in order to prevent noise coupling onto the analog signal path.

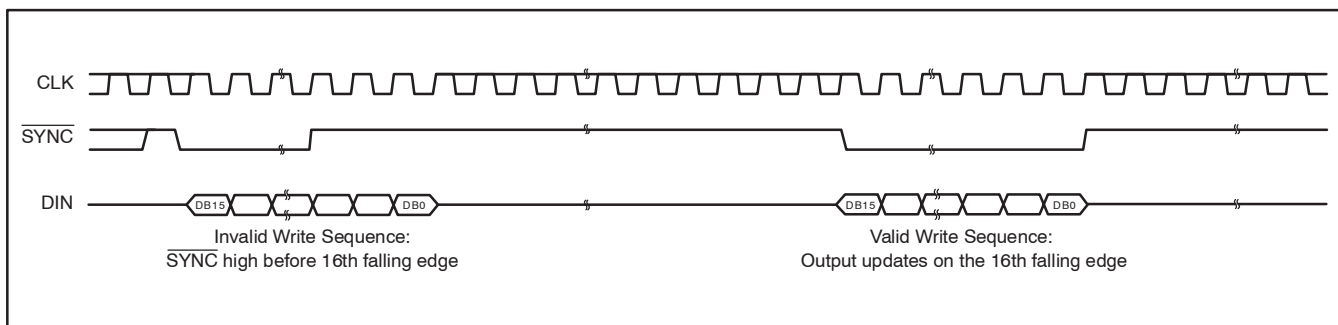

Figure 40.  $\overline{\text{SYNC}}$  Interrupt Facility

## Revision History

DATE	REV	PAGE	SECTION	DESCRIPTION
JUL 05	D	6	Timing Requirements	Changed tS1, tS2, tH1, tH2 min values, $\overline{\text{CS}}$ hold time (pulse width) min value, and $\overline{\text{CS}}$ to clock rising or falling edge setup time typ value.
		8	Pin Assignments	Changed pin names for pins 1 – 12
		8	Terminal Functions	Changed $\overline{\text{CS}}$ description.
		15	Power-Down Modes	In Table 1, changed column 1 row 7 from X to 0.
		16	Chip Select Operation	Added Chip Select Operation section with figure
		17	Differential With Transformer	Changed ratio and load in first paragraph. Changed ratio and load in Figure 30.
AUG 03	*	—	—	Original version

NOTE: Page numbers for previous revisions may differ from page numbers in the current version.

**PACKAGING INFORMATION**

Orderable Device	Status (1)	Package Type	Package Drawing	Pins	Package Qty	Eco Plan (2)	Lead/Ball Finish	MSL Peak Temp (3)	Op Temp (°C)	Top-Side Markings (4)	Samples
DAC2932PFBR	ACTIVE	TQFP	PFB	48	2000	Green (RoHS & no Sb/Br)	CU NIPDAU	Level-2-260C-1 YEAR	-40 to 85	DAC2932PFB	<a href="#">Samples</a>
DAC2932PFBRG4	ACTIVE	TQFP	PFB	48	2000	Green (RoHS & no Sb/Br)	CU NIPDAU	Level-2-260C-1 YEAR	-40 to 85	DAC2932PFB	<a href="#">Samples</a>
DAC2932PFBT	ACTIVE	TQFP	PFB	48	250	Green (RoHS & no Sb/Br)	CU NIPDAU	Level-2-260C-1 YEAR	-40 to 85	DAC2932PFB	<a href="#">Samples</a>
DAC2932PFBTG4	ACTIVE	TQFP	PFB	48	250	Green (RoHS & no Sb/Br)	CU NIPDAU	Level-2-260C-1 YEAR	-40 to 85	DAC2932PFB	<a href="#">Samples</a>

(1) The marketing status values are defined as follows:

**ACTIVE:** Product device recommended for new designs.

**LIFEBUY:** TI has announced that the device will be discontinued, and a lifetime-buy period is in effect.

**NRND:** Not recommended for new designs. Device is in production to support existing customers, but TI does not recommend using this part in a new design.

**PREVIEW:** Device has been announced but is not in production. Samples may or may not be available.

**OBSELETE:** TI has discontinued the production of the device.

(2) Eco Plan - The planned eco-friendly classification: Pb-Free (RoHS), Pb-Free (RoHS Exempt), or Green (RoHS & no Sb/Br) - please check <http://www.ti.com/productcontent> for the latest availability information and additional product content details.

**TBD:** The Pb-Free/Green conversion plan has not been defined.

**Pb-Free (RoHS):** TI's terms "Lead-Free" or "Pb-Free" mean semiconductor products that are compatible with the current RoHS requirements for all 6 substances, including the requirement that lead not exceed 0.1% by weight in homogeneous materials. Where designed to be soldered at high temperatures, TI Pb-Free products are suitable for use in specified lead-free processes.

**Pb-Free (RoHS Exempt):** This component has a RoHS exemption for either 1) lead-based flip-chip solder bumps used between the die and package, or 2) lead-based die adhesive used between the die and leadframe. The component is otherwise considered Pb-Free (RoHS compatible) as defined above.

**Green (RoHS & no Sb/Br):** TI defines "Green" to mean Pb-Free (RoHS compatible), and free of Bromine (Br) and Antimony (Sb) based flame retardants (Br or Sb do not exceed 0.1% by weight in homogeneous material)

(3) MSL, Peak Temp. -- The Moisture Sensitivity Level rating according to the JEDEC industry standard classifications, and peak solder temperature.

(4) Multiple Top-Side Markings will be inside parentheses. Only one Top-Side Marking contained in parentheses and separated by a "~" will appear on a device. If a line is indented then it is a continuation of the previous line and the two combined represent the entire Top-Side Marking for that device.

**Important Information and Disclaimer:** The information provided on this page represents TI's knowledge and belief as of the date that it is provided. TI bases its knowledge and belief on information provided by third parties, and makes no representation or warranty as to the accuracy of such information. Efforts are underway to better integrate information from third parties. TI has taken and continues to take reasonable steps to provide representative and accurate information but may not have conducted destructive testing or chemical analysis on incoming materials and chemicals. TI and TI suppliers consider certain information to be proprietary, and thus CAS numbers and other limited information may not be available for release.

In no event shall TI's liability arising out of such information exceed the total purchase price of the TI part(s) at issue in this document sold by TI to Customer on an annual basis.





**TAPE AND REEL INFORMATION**

**QUADRANT ASSIGNMENTS FOR PIN 1 ORIENTATION IN TAPE**

\*All dimensions are nominal

Device	Package Type	Package Drawing	Pins	SPQ	Reel Diameter (mm)	Reel Width W1 (mm)	A0 (mm)	B0 (mm)	K0 (mm)	P1 (mm)	W (mm)	Pin1 Quadrant
DAC2932PFBR	TQFP	PFB	48	2000	330.0	16.8	9.6	9.6	1.5	12.0	16.0	Q2
DAC2932PFBT	TQFP	PFB	48	250	177.8	16.4	9.6	9.6	1.5	12.0	16.0	Q2

**TAPE AND REEL BOX DIMENSIONS**

\*All dimensions are nominal

Device	Package Type	Package Drawing	Pins	SPQ	Length (mm)	Width (mm)	Height (mm)
DAC2932PFBR	TQFP	PFB	48	2000	367.0	367.0	38.0
DAC2932PFBT	TQFP	PFB	48	250	210.0	185.0	35.0

PFB (S-PQFP-G48)

PLASTIC QUAD FLATPACK



- NOTES: A. All linear dimensions are in millimeters.  
 B. This drawing is subject to change without notice.  
 C. Falls within JEDEC MS-026

PFB (S-PQFP-G48)



- NOTES:
- A. All linear dimensions are in millimeters.
  - B. This drawing is subject to change without notice.
  - C. Publication IPC-7351 is recommended for alternate designs.
  - D. Laser cutting apertures with trapezoidal walls and also rounding corners will offer better paste release. Customers should contact their board assembly site for stencil design recommendations. Refer to IPC-7525.
  - E. Customers should contact their board fabrication site for solder mask tolerances between and around signal pads.

## IMPORTANT NOTICE

Texas Instruments Incorporated and its subsidiaries (TI) reserve the right to make corrections, enhancements, improvements and other changes to its semiconductor products and services per JESD46, latest issue, and to discontinue any product or service per JESD48, latest issue. Buyers should obtain the latest relevant information before placing orders and should verify that such information is current and complete. All semiconductor products (also referred to herein as "components") are sold subject to TI's terms and conditions of sale supplied at the time of order acknowledgment.

TI warrants performance of its components to the specifications applicable at the time of sale, in accordance with the warranty in TI's terms and conditions of sale of semiconductor products. Testing and other quality control techniques are used to the extent TI deems necessary to support this warranty. Except where mandated by applicable law, testing of all parameters of each component is not necessarily performed.

TI assumes no liability for applications assistance or the design of Buyers' products. Buyers are responsible for their products and applications using TI components. To minimize the risks associated with Buyers' products and applications, Buyers should provide adequate design and operating safeguards.

TI does not warrant or represent that any license, either express or implied, is granted under any patent right, copyright, mask work right, or other intellectual property right relating to any combination, machine, or process in which TI components or services are used. Information published by TI regarding third-party products or services does not constitute a license to use such products or services or a warranty or endorsement thereof. Use of such information may require a license from a third party under the patents or other intellectual property of the third party, or a license from TI under the patents or other intellectual property of TI.

Reproduction of significant portions of TI information in TI data books or data sheets is permissible only if reproduction is without alteration and is accompanied by all associated warranties, conditions, limitations, and notices. TI is not responsible or liable for such altered documentation. Information of third parties may be subject to additional restrictions.

Resale of TI components or services with statements different from or beyond the parameters stated by TI for that component or service voids all express and any implied warranties for the associated TI component or service and is an unfair and deceptive business practice. TI is not responsible or liable for any such statements.

Buyer acknowledges and agrees that it is solely responsible for compliance with all legal, regulatory and safety-related requirements concerning its products, and any use of TI components in its applications, notwithstanding any applications-related information or support that may be provided by TI. Buyer represents and agrees that it has all the necessary expertise to create and implement safeguards which anticipate dangerous consequences of failures, monitor failures and their consequences, lessen the likelihood of failures that might cause harm and take appropriate remedial actions. Buyer will fully indemnify TI and its representatives against any damages arising out of the use of any TI components in safety-critical applications.

In some cases, TI components may be promoted specifically to facilitate safety-related applications. With such components, TI's goal is to help enable customers to design and create their own end-product solutions that meet applicable functional safety standards and requirements. Nonetheless, such components are subject to these terms.

No TI components are authorized for use in FDA Class III (or similar life-critical medical equipment) unless authorized officers of the parties have executed a special agreement specifically governing such use.

Only those TI components which TI has specifically designated as military grade or "enhanced plastic" are designed and intended for use in military/aerospace applications or environments. Buyer acknowledges and agrees that any military or aerospace use of TI components which have **not** been so designated is solely at the Buyer's risk, and that Buyer is solely responsible for compliance with all legal and regulatory requirements in connection with such use.

TI has specifically designated certain components as meeting ISO/TS16949 requirements, mainly for automotive use. In any case of use of non-designated products, TI will not be responsible for any failure to meet ISO/TS16949.

### Products

Audio	<a href="http://www.ti.com/audio">www.ti.com/audio</a>
Amplifiers	<a href="http://amplifier.ti.com">amplifier.ti.com</a>
Data Converters	<a href="http://dataconverter.ti.com">dataconverter.ti.com</a>
DLP® Products	<a href="http://www.dlp.com">www.dlp.com</a>
DSP	<a href="http://dsp.ti.com">dsp.ti.com</a>
Clocks and Timers	<a href="http://www.ti.com/clocks">www.ti.com/clocks</a>
Interface	<a href="http://interface.ti.com">interface.ti.com</a>
Logic	<a href="http://logic.ti.com">logic.ti.com</a>
Power Mgmt	<a href="http://power.ti.com">power.ti.com</a>
Microcontrollers	<a href="http://microcontroller.ti.com">microcontroller.ti.com</a>
RFID	<a href="http://www.ti-rfid.com">www.ti-rfid.com</a>
OMAP Applications Processors	<a href="http://www.ti.com/omap">www.ti.com/omap</a>
Wireless Connectivity	<a href="http://www.ti.com/wirelessconnectivity">www.ti.com/wirelessconnectivity</a>

### Applications

Automotive and Transportation	<a href="http://www.ti.com/automotive">www.ti.com/automotive</a>
Communications and Telecom	<a href="http://www.ti.com/communications">www.ti.com/communications</a>
Computers and Peripherals	<a href="http://www.ti.com/computers">www.ti.com/computers</a>
Consumer Electronics	<a href="http://www.ti.com/consumer-apps">www.ti.com/consumer-apps</a>
Energy and Lighting	<a href="http://www.ti.com/energy">www.ti.com/energy</a>
Industrial	<a href="http://www.ti.com/industrial">www.ti.com/industrial</a>
Medical	<a href="http://www.ti.com/medical">www.ti.com/medical</a>
Security	<a href="http://www.ti.com/security">www.ti.com/security</a>
Space, Avionics and Defense	<a href="http://www.ti.com/space-avionics-defense">www.ti.com/space-avionics-defense</a>
Video and Imaging	<a href="http://www.ti.com/video">www.ti.com/video</a>

### TI E2E Community

[e2e.ti.com](http://e2e.ti.com)