



Integrated Analog Front-End for Pulse Oximeters

Check for Samples: [AFE4490](#)

FEATURES

- Fully-Integrated Analog Front-End for Pulse Oximeter Applications:
 - Flexible Pulse Sequencing and Timing Control
- Transmit:
 - Integrated LED Driver (H-Bridge or Push/Pull)
 - 110-dB Dynamic Range Across Full Range (Enables Low Noise at Low LED Current)
 - LED Current:
 - Programmable Ranges of 50 mA, 75 mA, 100 mA, 150 mA, and 200 mA, Each with 8-Bit Current Resolution
 - Low Power:
 - 100 μ A + Average LED Current
 - LED On-Time Programmability from (50 μ s + Settle Time) to 4 ms
 - Independent LED2 and LED1 Current Reference
- Receive Channel with High Dynamic Range:
 - Input-Referred Noise: 50 pA_{RMS} (at 5- μ A PD Current)
 - 13.5 Noise-Free Bits (at 5- μ A PD Current)
 - Analog Ambient Cancellation Scheme with Selectable 1- μ A to 10- μ A Ambient Current
 - Low Power: < 2.3 mA at 3.0-V Supply
 - Rx Sample Time: 50 μ s to 250 μ s
 - I-V Amplifier with Seven Separate LED2 and LED1 Programmable Feedback R and C Settings
 - Integrated Digital Ambient Estimation and Subtraction
- Integrated Fault Diagnostics:
 - Photodiode and LED Open and Short Detection
 - Cable On/Off Detection
- Supplies:
 - Rx = 2.0 V to 3.6 V
 - Tx = 3.0 V or 5.25 V

- Package: Compact QFN-40 (6 mm \times 6 mm)
- Specified Temperature Range: -40°C to $+85^{\circ}\text{C}$

APPLICATIONS

- Medical Pulse Oximeter Applications
- Industrial Photometry Applications

DESCRIPTION

The AFE4490 is a fully-integrated analog front-end (AFE) that is ideally suited for pulse-oximeter applications. The device consists of a low-noise receiver channel with a 22-bit analog-to-digital converter (ADC), an LED transmit section, and diagnostics for sensor and LED fault detection. The AFE4490 is a very configurable timing controller. This flexibility enables the user to have complete control of the device timing characteristics. To ease clocking requirements and provide a low-jitter clock to the AFE4490, an oscillator is also integrated that functions from an external crystal. The device communicates to an external microcontroller or host processor using an SPI™ interface.

The AFE4490 is a complete AFE solution packaged in a single, compact QFN-40 package (6 mm \times 6 mm) and is specified over the operating temperature range of -40°C to $+85^{\circ}\text{C}$.

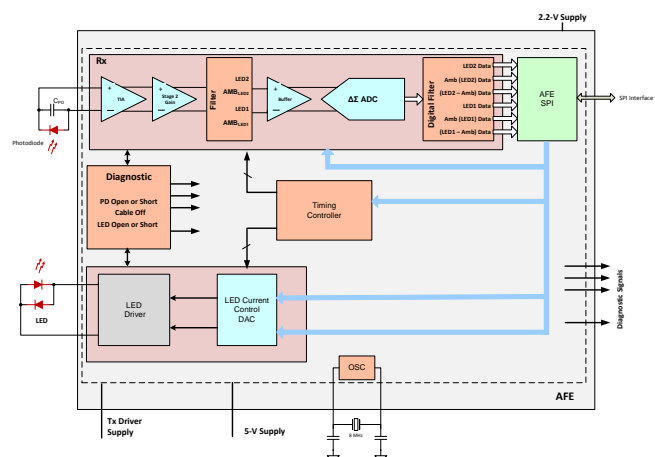

Please be aware that an important notice concerning availability, standard warranty, and use in critical applications of Texas Instruments semiconductor products and disclaimers thereto appears at the end of this data sheet.

SPI is a trademark of Motorola.

All other trademarks are the property of their respective owners.



This integrated circuit can be damaged by ESD. Texas Instruments recommends that all integrated circuits be handled with appropriate precautions. Failure to observe proper handling and installation procedures can cause damage.

ESD damage can range from subtle performance degradation to complete device failure. Precision integrated circuits may be more susceptible to damage because very small parametric changes could cause the device not to meet its published specifications.

FAMILY AND ORDERING INFORMATION

PRODUCT	PACKAGE-LEAD	LED DRIVE CONFIGURATION	LED DRIVE CURRENT (mA, max)	POWER SUPPLY (V)	OPERATING TEMPERATURE RANGE
AFE4490	QFN-40	Bridge, push-pull	50, 75, 100, 150, and 200	3 to 5.25	–40°C to +85°C
AFE4400	QFN-40	Bridge, push-pull	50	3 to 3.6	0°C to +70°C

ABSOLUTE MAXIMUM RATINGS⁽¹⁾

Over operating free-air temperature range, unless otherwise noted.

	VALUE	UNIT
AVDD to AVSS	–0.3 to +7	V
DVDD to DGND	–0.3 to +7	V
AGND to DGND	–0.3 to +0.3	V
Analog input to AVSS	AVSS – 0.3 to AVDD + 0.3	V
Digital input to DVDD	DVSS – 0.3 to DVDD + 0.3	V
Input current to any pin except supply pins ⁽²⁾	±7	mA
Input current	Momentary	±50
	Continuous	±7
Operating temperature range	–40 to +85	°C
Storage temperature range, T _{stg}	–60 to +150	°C
Maximum junction temperature, T _J	+125	°C
Electrostatic discharge (ESD) ratings	Human body model (HBM) JEDEC standard 22, test method A114-C.01, all pins	±4000
	Charged device model (CDM) JEDEC standard 22, test method C101, all pins	±1500

- (1) Stresses beyond those listed under *Absolute Maximum Ratings* may cause permanent damage to the device. These are stress ratings only, and do not imply functional operation of the device at these or any other conditions beyond those indicated under *Recommended Operating Conditions*. Exposure to absolute-maximum-rated conditions for extended periods may affect device reliability.
- (2) Input terminals are diode-clamped to the power-supply rails. Input signals that can swing beyond the supply rails must be current-limited to 10 mA or less.

THERMAL INFORMATION

THERMAL METRIC ⁽¹⁾		AFE4490	UNITS
		RHA (QFN)	
		40 PINS	
θ_{JA}	Junction-to-ambient thermal resistance	35	°C/W
$\theta_{Jc\text{top}}$	Junction-to-case (top) thermal resistance	31	
θ_{JB}	Junction-to-board thermal resistance	26	
Ψ_{JT}	Junction-to-top characterization parameter	0.1	
Ψ_{JB}	Junction-to-board characterization parameter	N/A	
$\theta_{Jc\text{bot}}$	Junction-to-case (bottom) thermal resistance	N/A	

- (1) For more information about traditional and new thermal metrics, see the *IC Package Thermal Metrics* application report, [SPRA953](#).

RECOMMENDED OPERATING CONDITIONS

Over operating free-air temperature range, unless otherwise noted.

PARAMETER		VALUE	UNIT
SUPPLIES			
RX_ANA_SUP	AFE analog supply	2.0 to 3.6	V
RX_DIG_SUP	AFE digital supply	2.0 to 3.6	V
TX_CTRL_SUP	Transmit controller supply	3.0 to 5.25	V
LED_DRV_SUP	Transmit LED driver supply	[3.0 or (1.4 + V_{LED} + V_{CABLE}) ⁽¹⁾⁽²⁾ , whichever is greater] to 5.25	V
	H-bridge configuration		
	Common anode configuration	[3.0 or (1.3 + V_{LED} + V_{CABLE}) ⁽¹⁾⁽²⁾ , whichever is greater] to 5.25	V
Difference between LED_DRV_SUP and TX_CTRL_SUP		-0.3 to +0.3	V
TEMPERATURE			
Specified temperature range		-40 to +85	°C
Storage temperature range		-60 to +150	°C

- (1) V_{LED} refers to the voltage drop across the external LED connected between the TXP and TXM pins (in H-bridge mode) and from the TXP and TXM pins to LED_DRV_SUP (in the common anode configuration).
- (2) V_{CABLE} refers to voltage drop across any cable, connector, or any other component in series with the LED.

ELECTRICAL CHARACTERISTICS

Minimum and maximum specifications are at $T_A = -40^\circ\text{C}$ to $+85^\circ\text{C}$. Typical specifications are at $+25^\circ\text{C}$.

All specifications are at $RX_ANA_SUP = RX_DIG_SUP = 3\text{ V}$, $TX_CTRL_SUP = LED_DRV_SUP = 5\text{ V}$, and $f_{CLK} = 8\text{ MHz}$, unless otherwise noted.

PARAMETER	TEST CONDITIONS	MIN	TYP	MAX	UNIT
PERFORMANCE (Full-Signal Chain)					
I_{IN_FS}	Full-scale input current				
	$R_F = 10\text{ k}\Omega$		50		μA
	$R_F = 25\text{ k}\Omega$		20		μA
	$R_F = 50\text{ k}\Omega$		10		μA
	$R_F = 100\text{ k}\Omega$		5		μA
	$R_F = 250\text{ k}\Omega$		2		μA
	$R_F = 500\text{ k}\Omega$		1		μA
	$R_F = 1\text{ M}\Omega$		0.5		μA
PRF	Pulse repetition frequency	61		5000	SPS
DC _{PRF}	PRF duty cycle			25%	
I_{IN_FS}	Full-scale input current				
	$R_F = 10\text{ k}\Omega$		50		μA
	$R_F = 1\text{ M}\Omega$		0.5		μA
CMRR	Common-mode rejection ratio				
	$f_{CM} = 50\text{ Hz}$ and 60 Hz , LED1 and LED2 with $R_{SERIES} = 500\text{ k}\Omega$, $R_F = 500\text{ k}\Omega$		75		dB
	$f_{CM} = 50\text{ Hz}$ and 60 Hz , LED1-AMB and LED2-AMB with $R_{SERIES} = 500\text{ k}\Omega$, $R_F = 500\text{ k}\Omega$		95		dB
PSRR	Power-supply rejection ratio				
	$f_{PS} = 50\text{ Hz}$, 60 Hz at PRF = 200 Hz		100		dB
	$f_{CM} = 50\text{ Hz}$, 60 Hz at PRF = 600 Hz		106		dB
PSRR _{LED}	PSRR, transmit LED driver		75		dB
PSRR _{TX}	PSRR, transmit control		60		dB
PSRR _{Rx}	PSRR, receiver		60		dB
	Total integrated noise current, input-referred (receiver with transmitter loop back, 0.1-Hz to 20-Hz bandwidth)	$R_F = 100\text{ k}\Omega$ with stage 2 gain disabled, PRF = 1300 Hz , duty cycle = 5%	36		pA_{RMS}
	$R_F = 500\text{ k}\Omega$ with ambient cancellation enabled and stage 2 gain = 4, PRF = 1300 Hz , duty cycle = 25%	13		pA_{RMS}	
N_{FB}	Noise-free bits (receiver with transmitter loop back, 0.1-Hz to 20-Hz bandwidth) ⁽¹⁾	$R_F = 100\text{ k}\Omega$, PRF = 1300 Hz , duty cycle = 5%	14.3		Bits
	$R_F = 500\text{ k}\Omega$, PRF = 1300 Hz , duty cycle = 25%	13.5		Bits	
RECEIVER FUNCTIONAL BLOCK LEVEL SPECIFICATION					
	Total integrated noise current, input-referred (receiver alone) over 0.1-Hz to 5-Hz bandwidth	$R_F = 500\text{ k}\Omega$, ambient cancellation enabled, stage 2 gain = 4, PRF = 1300 Hz , LED duty cycle = 25%	1.4		pA_{RMS}
	$R_F = 500\text{ k}\Omega$, ambient cancellation enabled, stage 2 gain = 4, PRF = 1300 Hz , LED duty cycle = 5%	5		pA_{RMS}	

(1) Noise-free bits (N_{FB}) are defined as:

$$N_{FB} = \log_2 \left(\frac{I_{PD}}{6.6 \times I_{NOISE}} \right)$$

where:

I_{PD} is the photodiode current, and I_{NOISE} is the input-referred RMS noise current.

ELECTRICAL CHARACTERISTICS (continued)

Minimum and maximum specifications are at $T_A = -40^\circ\text{C}$ to $+85^\circ\text{C}$. Typical specifications are at $+25^\circ\text{C}$.

All specifications are at $RX_ANA_SUP = RX_DIG_SUP = 3\text{ V}$, $TX_CTRL_SUP = LED_DRV_SUP = 5\text{ V}$, and $f_{CLK} = 8\text{ MHz}$, unless otherwise noted.

PARAMETER		TEST CONDITIONS	MIN	TYP	MAX	UNIT
I-V TRANSIMPEDANCE AMPLIFIER						
G	Gain	$R_F = 10\text{ k}\Omega$ to $R_F = 1\text{ M}\Omega$	See the Receiver Channel section for details			V/ μA
	Gain accuracy		$\pm 7\%$			
	Feedback resistance	R_F	10k, 25k, 50k, 100k, 250k, 500k, and 1M			Ω
	Feedback resistor tolerance	R_F	$\pm 7\%$			
	Feedback capacitance	C_F	5, 10, 25, 50, 100, and 250			pF
	Feedback capacitor tolerance	C_F	$\pm 20\%$			
$V_{OD(fs)}$	Full-scale differential output voltage		1			V
	Common-mode voltage on input pins	Set internally	0.9			V
	External differential input capacitance	Includes equivalent capacitance of photodiode, cables, EMI filter, and so forth	10	1000		pF
$V_{O(shield)}$	Shield output voltage, V_{CM}	With a 1-k Ω series resistor and a 10-nF decoupling capacitor to ground	0.9			V
AMBIENT CANCELLATION STAGE						
G	Gain		1, 1.414, 2, 2.828, and 4			V/V
	Current DAC range		0	10		μA
	Current DAC step size		1			μA
LOW-PASS FILTER						
	Low-pass corner frequency	3-dB attenuation	0.5 and 1			kHz
	Pass-band attenuation, 2 Hz to 10 Hz	Duty cycle = 25%	0.004			dB
		Duty cycle = 10%	0.041			dB
ANALOG-TO-DIGITAL CONVERTER						
	Resolution		22			Bits
	Sample rate	See the ADC Operation and Averaging Module section	4 x PRF			SPS
	ADC full-scale voltage		± 1.2			V
	ADC conversion time	See the ADC Operation and Averaging Module section	50	PRF / 4		μs
	ADC reset time		2			t_{CLK}
TRANSMITTER						
	Output current range		0, 50, 75, 100, 150, and 200 (see the LEDCNTRL: LED Control Register for details)			mA
	LED current DAC error		$\pm 5\%$			
	Output current resolution		8			Bits
	Transmitter noise dynamic range	0.1-Hz to 20-Hz bandwidth, at 25-mA output current	110			dB
		0.1-Hz to 20-Hz bandwidth, at 100-mA output current	110			dB
	Minimum sample time of LED1 and LED2 pulses		50			μs
	LED current DAC leakage current	LED_ON = 0	1			μA
		LED_ON = 1	50			μA
	LED current DAC linearity	Percent of full-scale current	0.5%			
	Output current settling time (with resistive load)	From zero current to 150 mA	7			μs
		From 150 mA to zero current	7			μs

ELECTRICAL CHARACTERISTICS (continued)

Minimum and maximum specifications are at $T_A = -40^{\circ}\text{C}$ to $+85^{\circ}\text{C}$. Typical specifications are at $+25^{\circ}\text{C}$.

All specifications are at $RX_ANA_SUP = RX_DIG_SUP = 3\text{ V}$, $TX_CTRL_SUP = LED_DRV_SUP = 5\text{ V}$, and $f_{CLK} = 8\text{ MHz}$, unless otherwise noted.

PARAMETER		TEST CONDITIONS	MIN	TYP	MAX	UNIT
DIAGNOSTICS						
Duration of diagnostics state machine		EN_SLOW_DIAG = 0 Start of diagnostics after the DIAG_EN register bit is set. End of diagnostic indicated by DIAG_END going high.		8		ms
		EN_SLOW_DIAG = 1 Start of diagnostics after the DIAG_EN register bit is set. End of diagnostic indicated by DIAG_END going high.		16		ms
Open fault resistance				> 100		k Ω
Short fault resistance				< 10		k Ω
INTERNAL OSCILLATOR						
f_{CLKOUT}	CLKOUT frequency	With an 8-MHz crystal connected to the XIN and XOUT pins		4		MHz
DC_{CLKOUT}	CLKOUT duty cycle			50%		
	Crystal oscillator start-up time	With an 8-MHz crystal connected to the XIN and XOUT pins		200		μs
EXTERNAL CLOCK						
	Maximum allowable external clock jitter				50	ps
	External clock input frequency	$\pm 10\%$		8		MHz
	External clock input voltage	Voltage input high (V_{IH})		$0.75 \times RX_DIG_SUP$		V
		Voltage input low (V_{IL})		$0.25 \times RX_DIG_SUP$		V
	External clock input current			1		μA
TIMING						
	Wake-up time from complete power-down			1000		ms
	Wake-up time from Rx power-down			100		μs
	Wake-up time from Tx power-down			1000		ms
$t_{\overline{RESET}}$	Active low \overline{RESET} pulse duration			1		ms
$t_{DIAGEND}$	DIAG_END pulse duration at diagnostics completion			4		CLKOUT cycles
t_{ADCRDY}	ADC_RDY pulse duration			1		CLKOUT cycles
DIGITAL SIGNAL CHARACTERISTICS						
V_{IH}	Logic high input voltage	$\overline{AFE_PDN}$, SPI CLK, SPI SIMO, SPI STE, \overline{RESET}		$0.75 \times RX_DIG_SUP$		V
V_{IL}	Logic low input voltage	$\overline{AFE_PDN}$, SPI CLK, SPI SIMO, SPI STE, \overline{RESET}		$0.25 \times RX_DIG_SUP$		V
I_{IN}	Logic input current	Digital inputs at V_{IH} or V_{IL}		0.1		μA
V_{OH}	Logic high output voltage	DIAG_END, LED_ALM, PD_ALM, SPI SOMI, ADC_RDY, CLKOUT		$RX_DIG_SUP - 0.1$		V
V_{OL}	Logic low output voltage	DIAG_END, LED_ALM, PD_ALM, SPI SOMI, ADC_RDY, CLKOUT			0.1	V
PIN LEAKAGE CURRENT						
	Pin leakage current	To GND and supply		1		nA

ELECTRICAL CHARACTERISTICS (continued)

Minimum and maximum specifications are at $T_A = -40^{\circ}\text{C}$ to $+85^{\circ}\text{C}$. Typical specifications are at $+25^{\circ}\text{C}$.

All specifications are at $\text{RX_ANA_SUP} = \text{RX_DIG_SUP} = 3\text{ V}$, $\text{TX_CTRL_SUP} = \text{LED_DRV_SUP} = 5\text{ V}$, and $f_{\text{CLK}} = 8\text{ MHz}$, unless otherwise noted.

PARAMETER		TEST CONDITIONS	MIN	TYP	MAX	UNIT
SUPPLY CURRENT						
Receiver analog supply current	RX_ANA_SUP = 3.0 V, with 8-MHz clock running, Rx stage 2 disabled			0.6		mA
	RX_ANA_SUP = 3.0 V, with 8-MHz clock running, Rx stage 2 enabled			0.7		mA
Receiver digital supply current	RX_DIG_SUP = 3.0 V			0.27		mA
ADC bypass mode	RX_ANA_SUP + RX_DIG_SUP (Excluding external ADC current)			1.8		mA
LED_DRV_SUP LED driver supply current	With zero LED current setting			55		μA
TX_CTRL_SUP Transmitter control supply current				15		μA
Complete power-down (using AFE_PDN pin)	Receiver current only (RX_ANA_SUP)			3		μA
	Receiver current only (RX_DIG_SUP)			3		μA
	Transmitter current only (LED_DRV_SUP)			1		μA
	Transmitter current only (TX_CTRL_SUP)			1		μA
Power-down Rx alone	Receiver current only (RX_ANA_SUP)			220		μA
	Receiver current only (RX_DIG_SUP)			220		μA
Power-down Tx alone	Transmitter current only (LED_DRV_SUP)			2		μA
	Transmitter current only (TX_CTRL_SUP)			2		μA

ELECTRICAL CHARACTERISTICS (continued)

Minimum and maximum specifications are at $T_A = -40^\circ\text{C}$ to $+85^\circ\text{C}$. Typical specifications are at $+25^\circ\text{C}$.

All specifications are at $RX_ANA_SUP = RX_DIG_SUP = 3\text{ V}$, $TX_CTRL_SUP = LED_DRV_SUP = 5\text{ V}$, and $f_{CLK} = 8\text{ MHz}$, unless otherwise noted.

PARAMETER		TEST CONDITIONS	MIN	TYP	MAX	UNIT
POWER DISSIPATION						
$P_{D(q)}$	Quiescent power dissipation	Normal operation (excluding LEDs)		2.84		mW
		Power-down		0.1		mW
Power-down with the AFE_PDN pin	LED_DRV_SUP	LED_DRV_SUP current value. Does not include LED current.		1		μA
	TX_CTRL_SUP			1		μA
	RX_ANA_SUP			5		μA
	RX_DIG_SUP			0.1		μA
Power-down with the PDNAFE register bit	LED_DRV_SUP	LED_DRV_SUP current value. Does not include LED current.		1		μA
	TX_CTRL_SUP			1		μA
	RX_ANA_SUP			15		μA
	RX_DIG_SUP			20		μA
Power-down Rx	LED_DRV_SUP	LED_DRV_SUP current value. Does not include LED current.		50		μA
	TX_CTRL_SUP			15		μA
	RX_ANA_SUP			220		μA
	RX_DIG_SUP			220		μA
Power-down Tx	LED_DRV_SUP	LED_DRV_SUP current value. Does not include LED current.		2		μA
	TX_CTRL_SUP			2		μA
	RX_ANA_SUP			600		μA
	RX_DIG_SUP			230		μA
After reset, with 8-MHz clock running	LED_DRV_SUP	LED_DRV_SUP current value. Does not include LED current.		55		μA
	TX_CTRL_SUP			15		μA
	RX_ANA_SUP			600		μA
	RX_DIG_SUP			230		μA
With stage 2 mode enabled and 8-MHz clock running	LED_DRV_SUP	LED_DRV_SUP current value. Does not include LED current.		55		μA
	TX_CTRL_SUP			15		μA
	RX_ANA_SUP			700		μA
	RX_DIG_SUP			270		μA

PARAMETRIC MEASUREMENT INFORMATION

SERIAL INTERFACE TIMING

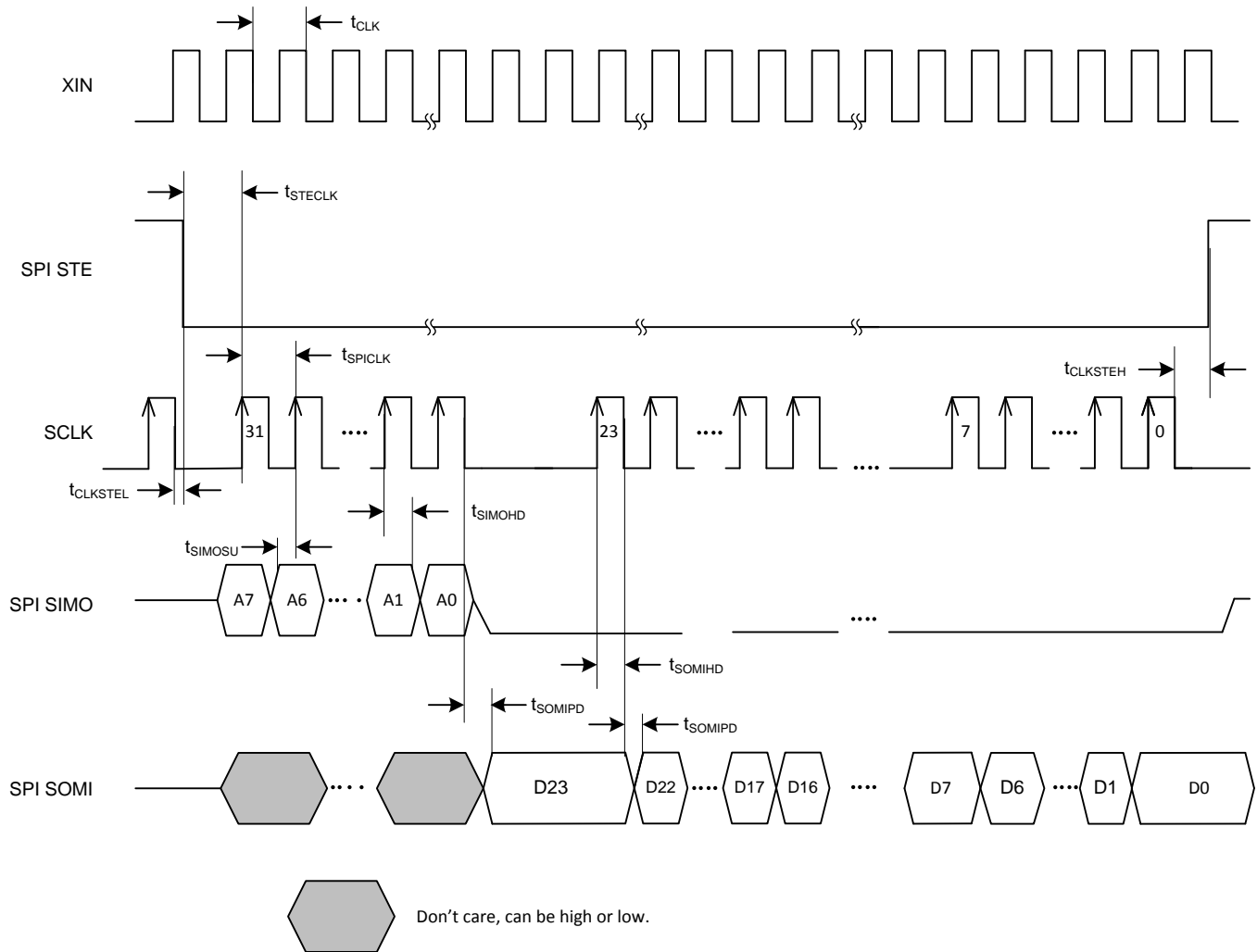

- (1) The SPI_READ register bit must be enabled before attempting a register read.
- (2) Specify the register address whose contents must be read back on A[7:0].
- (3) The AFE outputs the contents of the specified register on the SOMI pin.

Figure 1. Serial Interface Timing Diagram, Read Operation (1)(2)(3)

PARAMETRIC MEASUREMENT INFORMATION (continued)

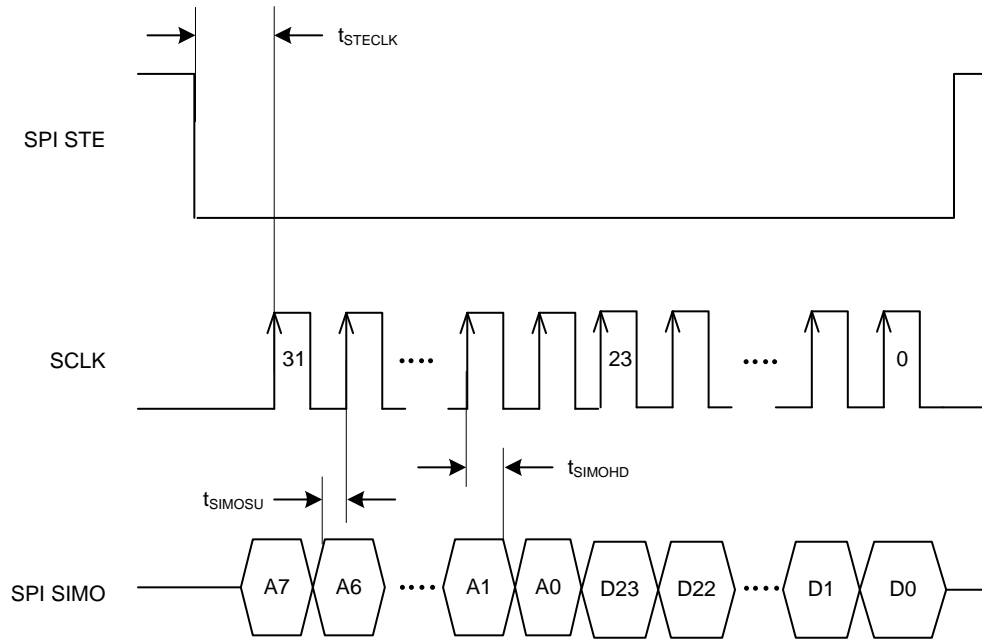
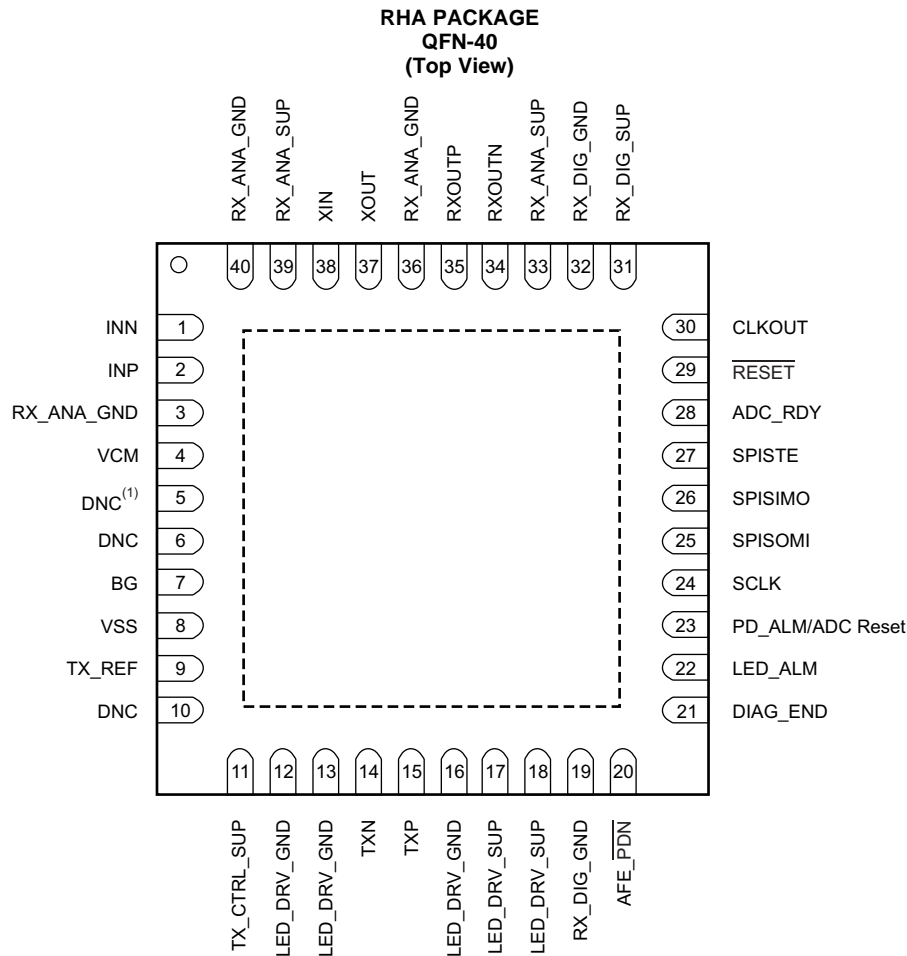

Figure 2. Serial Interface Timing Diagram, Write Operation

Table 1. Timing Requirements for [Figure 1](#) and [Figure 2](#)

PARAMETER		MIN	TYP	MAX	UNIT
t_{CLK}	Clock frequency on XIN pin		8		MHz
t_{SCLK}	Serial shift clock period	62.5			ns
t_{STECLK}	STE low to SCLK rising edge, setup time	10			ns
$t_{CLKSTEH,L}$	SCLK transition to SPI STE high or low	10			ns
t_{SIMOSU}	SIMO data to SCLK rising edge, setup time	10			ns
t_{SIMOHD}	Valid SIMO data after SCLK rising edge, hold time	10			ns
t_{SOMIPD}	SCLK falling edge to valid SOMI, setup time	17			ns
t_{SOMIHD}	SCLK rising edge to invalid data, hold time	0.5			t_{SCLK}

PIN CONFIGURATION



(1) DNC = Do not connect.

PIN DESCRIPTIONS

NAME	NO.	FUNCTION	DESCRIPTION
ADC_RDY	28	Digital	Output signal that indicates ADC conversion completion. Can be connected to the interrupt input pin of an external microcontroller.
AFE_PDN	20	Digital	AFE-only power-down input; active low. Can be connected to the port pin of an external microcontroller.
BG	7	Reference	Decoupling capacitor for internal band-gap voltage to ground (2.2- μ F decoupling capacitor to ground, expected voltage = 1.0 V).
CLKOUT	30	Digital	Buffered 4-MHz output clock output. Can be connected to the clock input pin of an external microcontroller.
DIAG_END	21	Digital	Output signal that indicates completion of diagnostics. Can be connected to the port pin of an external microcontroller.
DNC ⁽¹⁾	5, 6, 10	—	Do not connect these pins. Leave as open-circuit.
INN	1	Analog	Receiver input pin. Connect to photodiode anode.
INP	2	Analog	Receiver input pin. Connect to photodiode cathode.
LED_DRV_GND	12, 13, 16	Supply	LED driver ground pin, H-bridge. Connect to common board ground.
LED_DRV_SUP	17, 18	Supply	LED driver supply pin, H-bridge. Connect to an external power supply capable of supplying the large LED current, which is drawn by this supply pin.
LED_ALM	22	Digital	Output signal that indicates an LED cable fault. Can be connected to the port pin of an external microcontroller.

(1) Leave pins as open circuit. Do not connect.

PIN DESCRIPTIONS (continued)

NAME	NO.	FUNCTION	DESCRIPTION
PD_ALM/ADC Reset	23	Digital	Output signal that indicates a PD sensor or cable fault. Can be connected to the port pin of an external microcontroller. In ADC bypass mode, the PD_ALM pin can be used to bring out the ADC reset signal.
$\overline{\text{RESET}}$	29	Digital	AFE-only reset input, active low. Can be connected to the port pin of an external microcontroller.
RX_ANA_GND	3, 36, 40	Supply	Rx analog ground pin. Connect to common board ground.
RX_ANA_SUP	33, 39	Supply	Rx analog supply pin; 0.1- μF decoupling capacitor to ground
RX_DIG_GND	19, 32	Supply	Rx digital ground pin. Connect to common board ground.
RX_DIG_SUP	31	Supply	Rx digital supply pin; 0.1- μF decoupling capacitor to ground
RXOUTN	34	Analog	External ADC negative input when in ADC bypass mode
RXOUTP	35	Analog	External ADC positive input when in ADC bypass mode
SCLK	24	SPI	SPI clock pin
SPISIMO	26	SPI	SPI serial in master out
SPISOMI	25	SPI	SPI serial out master in
SPISTE	27	SPI	SPI serial interface enable
TX_CTRL_SUP	11	Supply	Transmit control supply pin (0.1- μF decoupling capacitor to ground)
TX_REF	9	Reference	Tx reference voltage
TXN	14	Analog	LED driver out B, H-bridge output. Connect to LED.
TXP	15	Analog	LED driver out B, H-bridge output. Connect to LED.
VCM	4	Reference	Input common-mode voltage output. Connect a series resistor (1 k Ω) and a decoupling capacitor (10 nF) to ground. The voltage across the capacitor can be used to shield (guard) the INP, INM traces. Expected voltage = 0.9 V.
VSS	8	Supply	Substrate ground. Connect to common board ground.
XOUT	37	Digital	Crystal oscillator pins. Connect an external 8-MHz crystal between these pins with the correct load capacitor (as specified by vendor) to ground.
XIN	38	Digital	Crystal oscillator pins. Connect an external 8-MHz crystal between these pins with the correct load capacitor (as specified by vendor) to ground.

TYPICAL CHARACTERISTICS

At $T_A = +25^\circ\text{C}$, $RX_ANA_SUP = RX_DIG_SUP = 3.0\text{ V}$, $TX_CTRL_SUP = LED_DRV_SUP = 5\text{ V}$, and $f_{CLK} = 8\text{ MHz}$, unless otherwise noted.

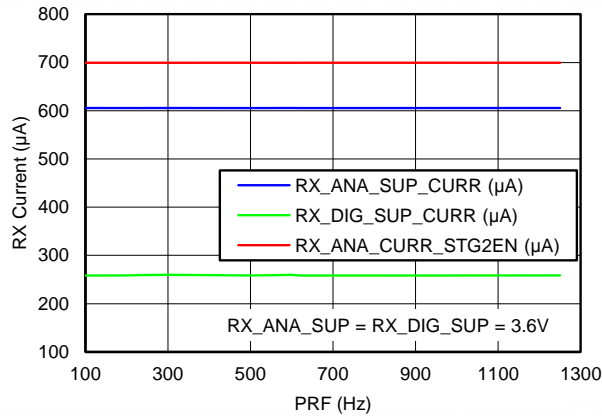

Figure 3. TOTAL Rx CURRENT vs PRF

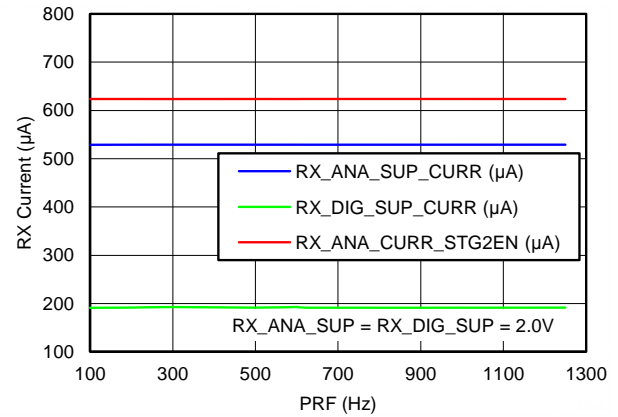

Figure 4. TOTAL Rx CURRENT vs PRF

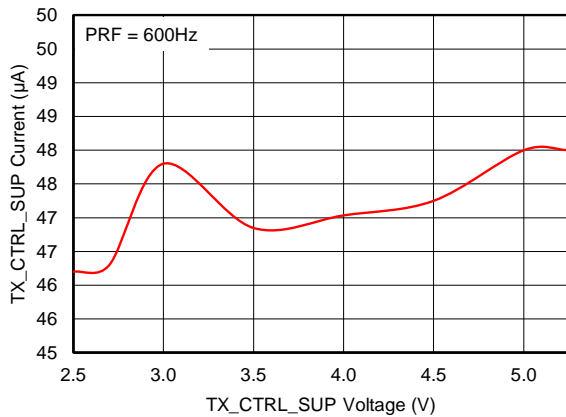

Figure 5. TX_CTRL_SUP CURRENT vs TX_CTRL_SUP VOLTAGE

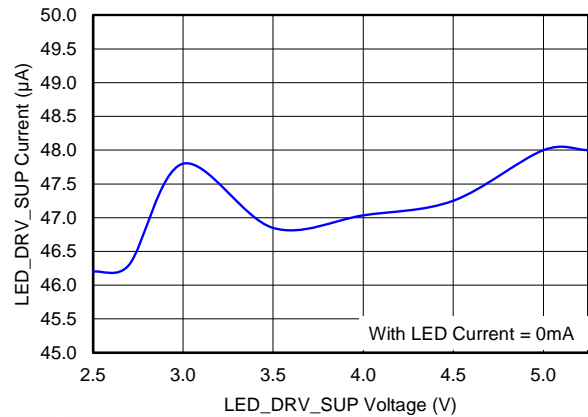

Figure 6. LED_DRV_SUP CURRENT vs LED_DRV_SUP VOLTAGE

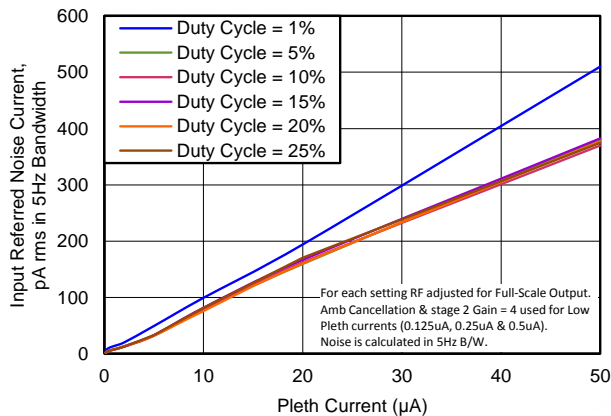

Figure 7. INPUT-REFERRED NOISE CURRENT vs PLETH CURRENT (BW = 5 Hz, PRF = 100 Hz)

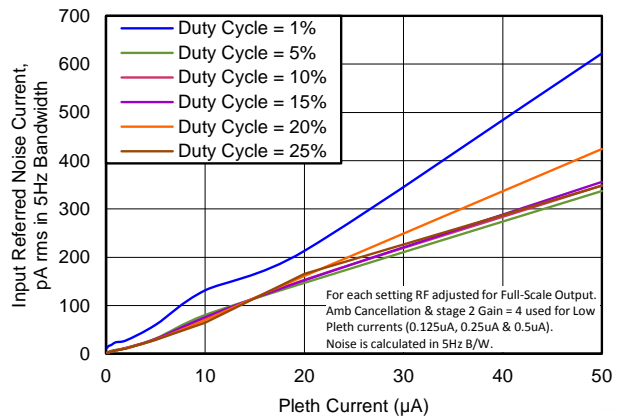

Figure 8. INPUT-REFERRED NOISE CURRENT vs PLETH CURRENT (BW = 5 Hz, PRF = 300 Hz)

TYPICAL CHARACTERISTICS (continued)

At $T_A = +25^\circ\text{C}$, $RX_ANA_SUP = RX_DIG_SUP = 3.0\text{ V}$, $TX_CTRL_SUP = LED_DRV_SUP = 5\text{ V}$, and $f_{CLK} = 8\text{ MHz}$, unless otherwise noted.

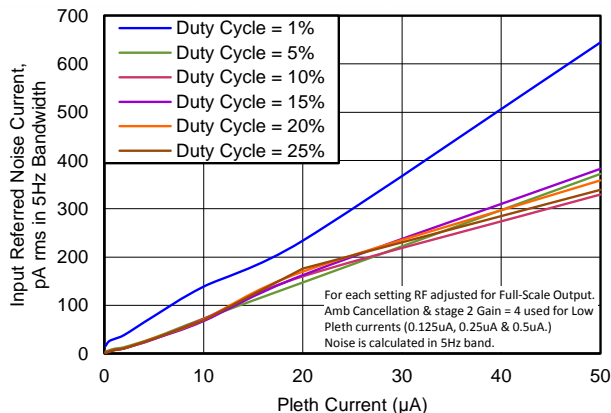

Figure 9. INPUT-REFERRED NOISE CURRENT vs PLETH CURRENT (BW = 5 Hz, PRF = 600 Hz)

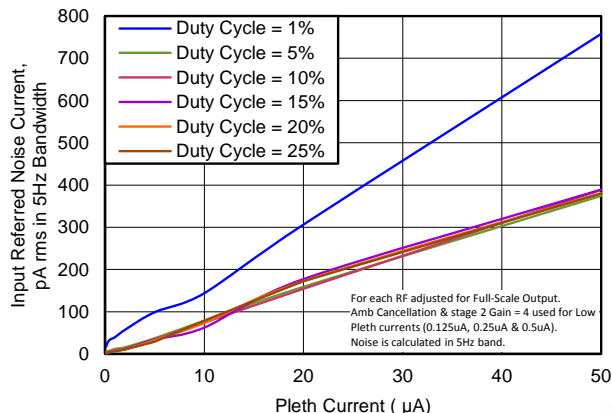

Figure 10. INPUT-REFERRED NOISE CURRENT vs PLETH CURRENT (BW = 5 Hz, PRF = 1200 Hz)

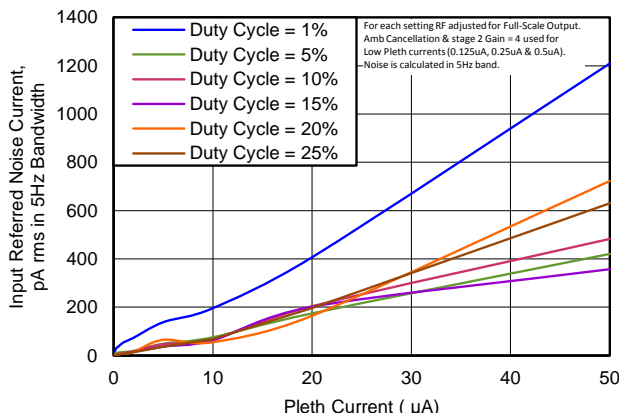

Figure 11. INPUT-REFERRED NOISE CURRENT vs PLETH CURRENT (BW = 5 Hz, PRF = 2500 Hz)

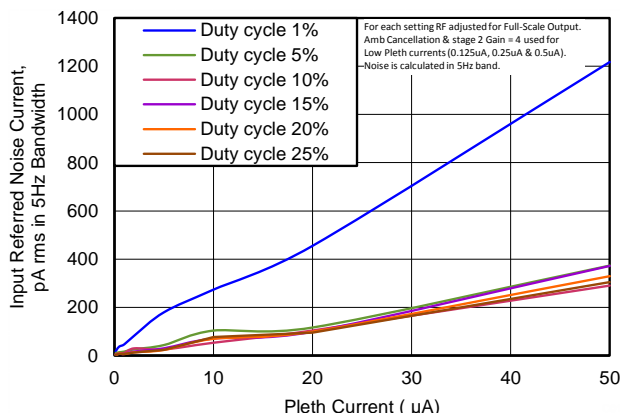

Figure 12. INPUT-REFERRED NOISE CURRENT vs PLETH CURRENT (BW = 5 Hz, PRF = 5000 Hz)

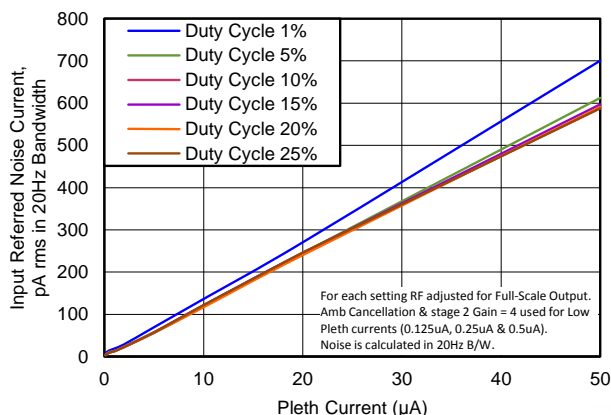

Figure 13. INPUT-REFERRED NOISE CURRENT vs PLETH CURRENT (BW = 20 Hz, PRF = 100 Hz)

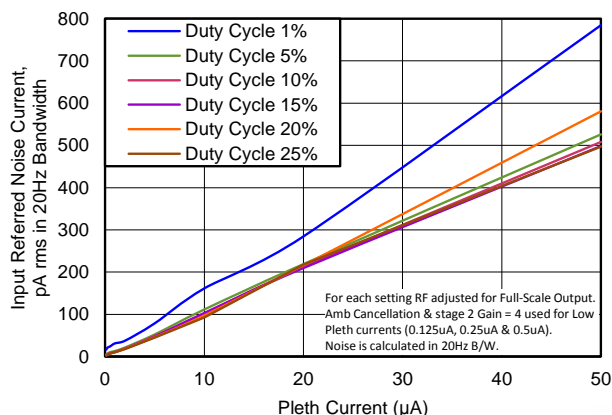

Figure 14. INPUT-REFERRED NOISE CURRENT vs PLETH CURRENT (BW = 20 Hz, PRF = 300 Hz)

TYPICAL CHARACTERISTICS (continued)

At $T_A = +25^\circ\text{C}$, $RX_ANA_SUP = RX_DIG_SUP = 3.0\text{ V}$, $TX_CTRL_SUP = LED_DRV_SUP = 5\text{ V}$, and $f_{CLK} = 8\text{ MHz}$, unless otherwise noted.

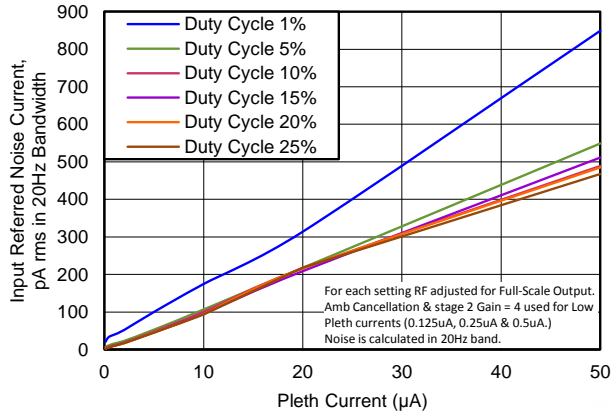

Figure 15. INPUT-REFERRED NOISE CURRENT vs PLETH CURRENT (BW = 20 Hz, PRF = 600 Hz)

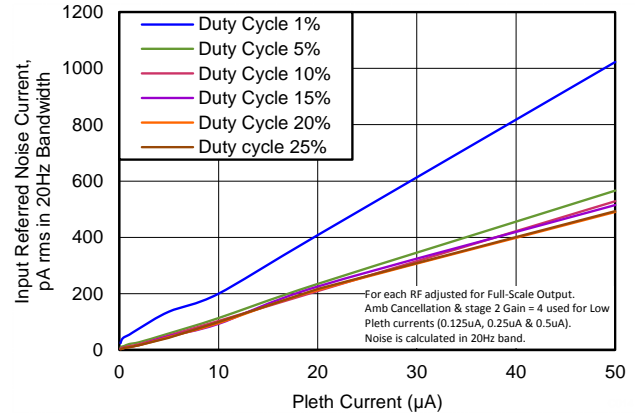

Figure 16. INPUT-REFERRED NOISE CURRENT vs PLETH CURRENT (BW = 20 Hz, PRF = 1200 Hz)

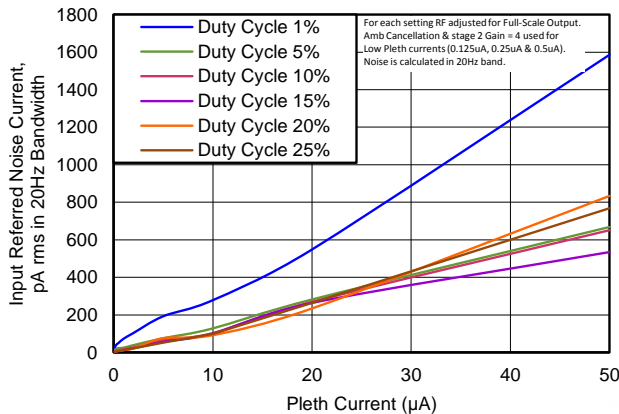

Figure 17. INPUT-REFERRED NOISE CURRENT vs PLETH CURRENT (BW = 20 Hz, PRF = 2500 Hz)

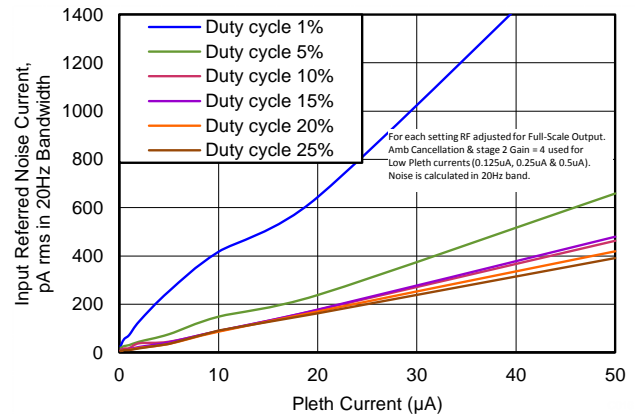

Figure 18. INPUT-REFERRED NOISE CURRENT vs PLETH CURRENT (BW = 20 Hz, PRF = 5000 Hz)

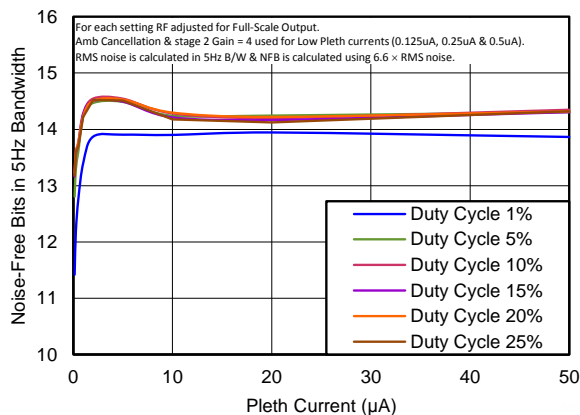

Figure 19. NOISE-FREE BITS vs PLETH CURRENT (BW = 5 Hz, PRF = 100 Hz)

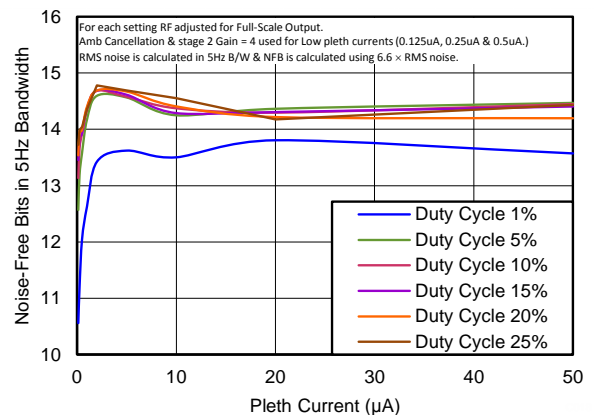

Figure 20. NOISE-FREE BITS vs PLETH CURRENT (BW = 5 Hz, PRF = 300 Hz)

TYPICAL CHARACTERISTICS (continued)

At $T_A = +25^\circ\text{C}$, $RX_ANA_SUP = RX_DIG_SUP = 3.0\text{ V}$, $TX_CTRL_SUP = LED_DRV_SUP = 5\text{ V}$, and $f_{CLK} = 8\text{ MHz}$, unless otherwise noted.

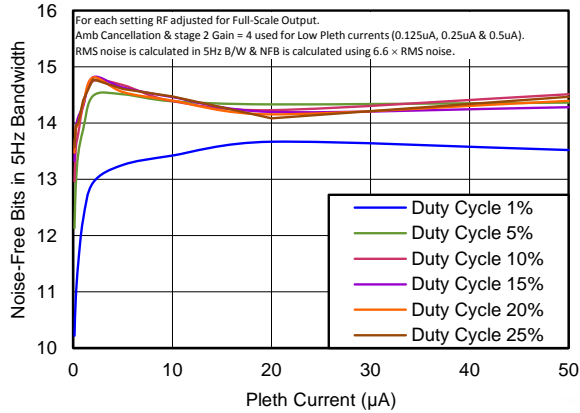

Figure 21. NOISE-FREE BITS vs PLETH CURRENT (BW = 5 Hz, PRF = 600 Hz)

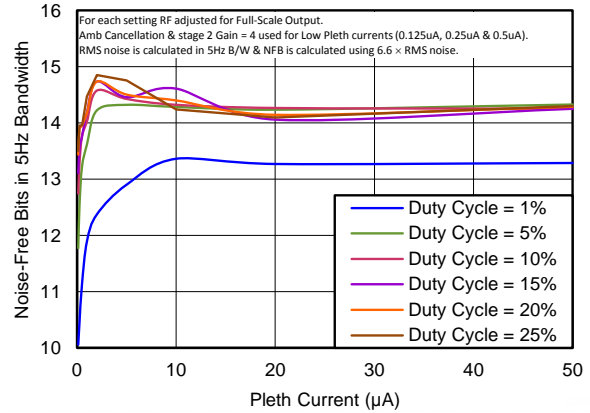

Figure 22. NOISE-FREE BITS vs PLETH CURRENT (BW = 5 Hz, PRF = 1200 Hz)

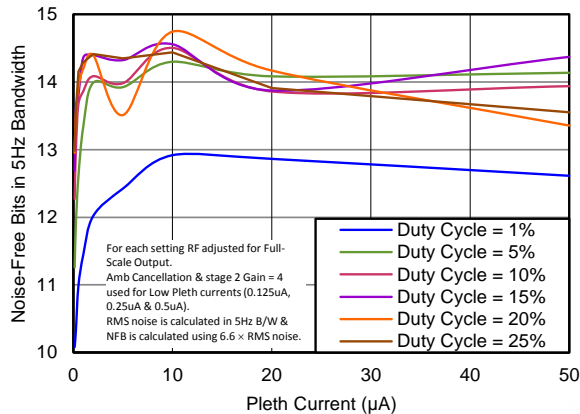

Figure 23. NOISE-FREE BITS vs PLETH CURRENT (BW = 5 Hz, PRF = 2500 Hz)

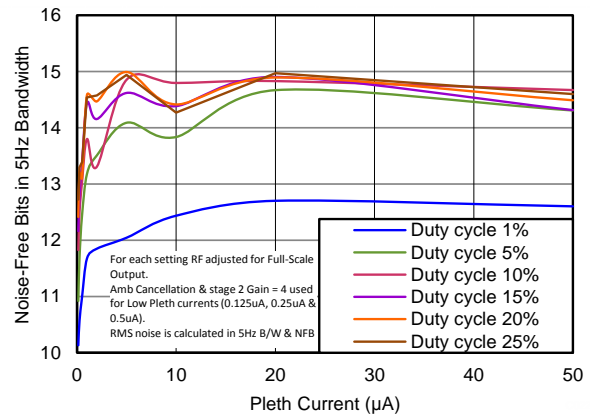

Figure 24. NOISE-FREE BITS vs PLETH CURRENT (BW = 5 Hz, PRF = 5000 Hz)

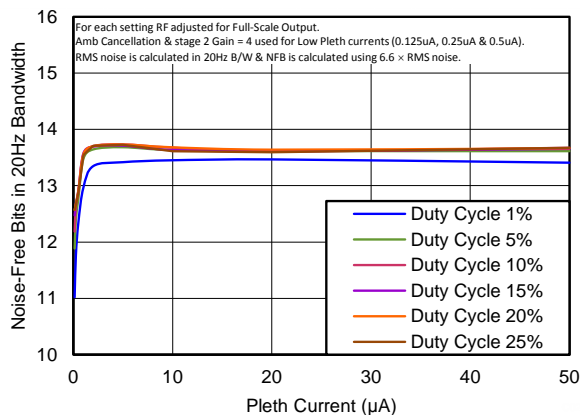

Figure 25. NOISE-FREE BITS vs PLETH CURRENT (BW = 20 Hz, PRF = 100 Hz)

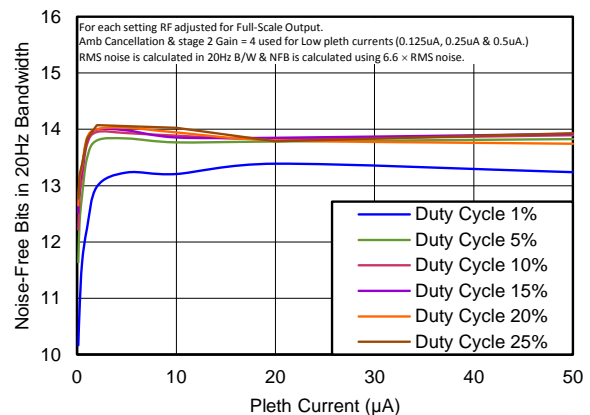

Figure 26. NOISE-FREE BITS vs PLETH CURRENT (BW = 20 Hz, PRF = 300 Hz)

TYPICAL CHARACTERISTICS (continued)

At $T_A = +25^\circ\text{C}$, $RX_ANA_SUP = RX_DIG_SUP = 3.0\text{ V}$, $TX_CTRL_SUP = LED_DRV_SUP = 5\text{ V}$, and $f_{CLK} = 8\text{ MHz}$, unless otherwise noted.

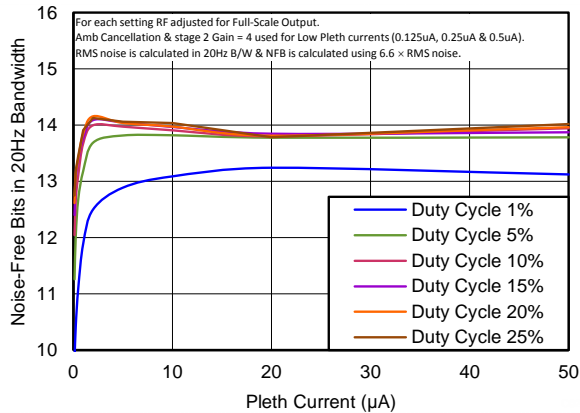

Figure 27. NOISE-FREE BITS vs PLETH CURRENT (BW = 20 Hz, PRF = 600 Hz)

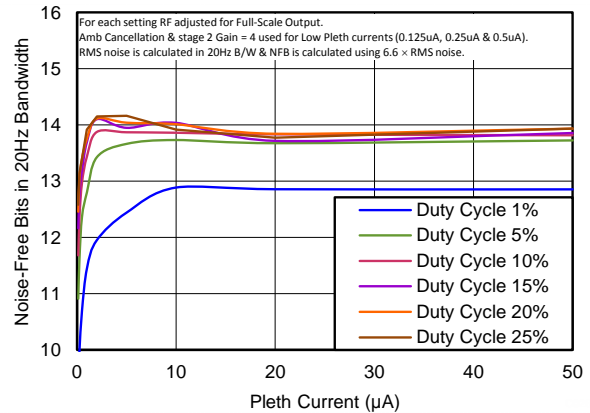

Figure 28. NOISE-FREE BITS vs PLETH CURRENT (BW = 20 Hz, PRF = 1200 Hz)

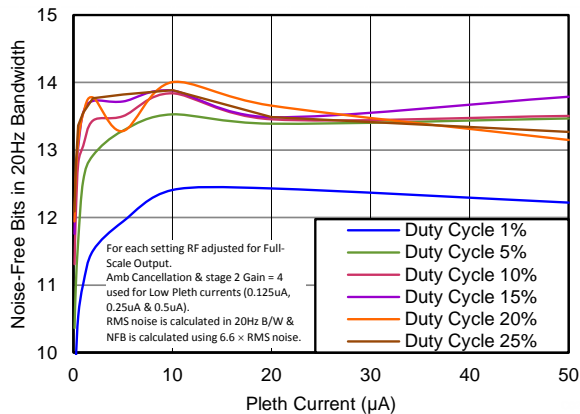

Figure 29. NOISE-FREE BITS vs PLETH CURRENT (BW = 20 Hz, PRF = 2500 Hz)

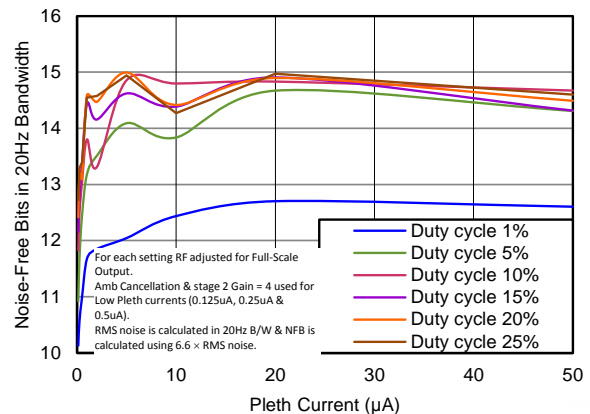

Figure 30. NOISE-FREE BITS vs PLETH CURRENT (BW = 20 Hz, PRF = 5000 Hz)

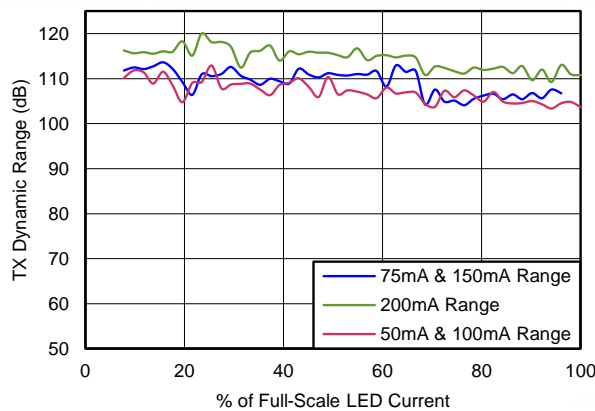

Figure 31. TRANSMITTER DYNAMIC RANGE (5-Hz BW)

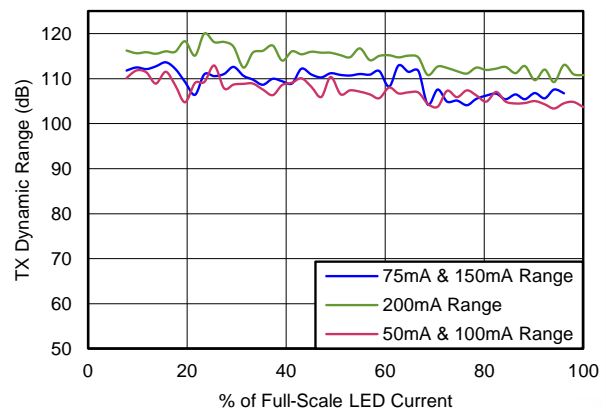

Figure 32. TRANSMITTER DYNAMIC RANGE (20-Hz BW)

TYPICAL CHARACTERISTICS (continued)

At $T_A = +25^\circ\text{C}$, $RX_ANA_SUP = RX_DIG_SUP = 3.0\text{ V}$, $TX_CTRL_SUP = LED_DRV_SUP = 5\text{ V}$, and $f_{CLK} = 8\text{ MHz}$, unless otherwise noted.

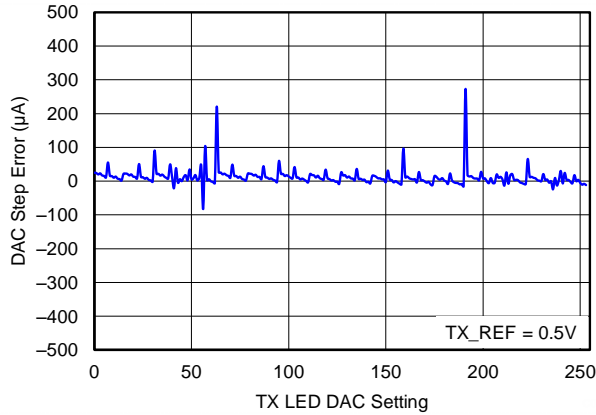

Figure 33. TRANSMITTER DAC CURRENT STEP ERROR (200 mA, Max)

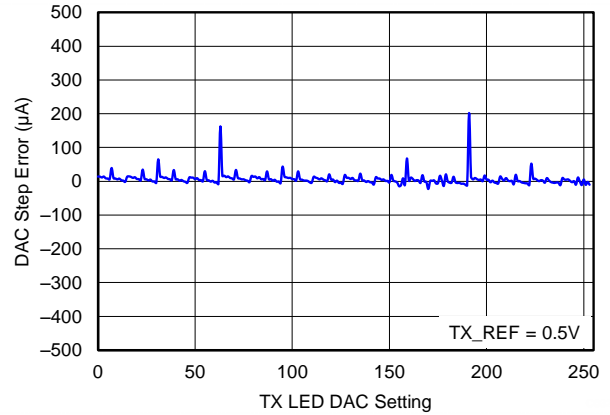

Figure 34. TRANSMITTER DAC CURRENT STEP ERROR (150 mA, Max)

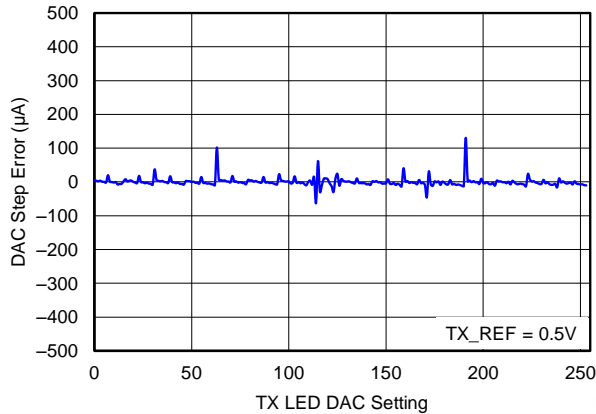

Figure 35. TRANSMITTER DAC CURRENT STEP ERROR (100 mA, Max)

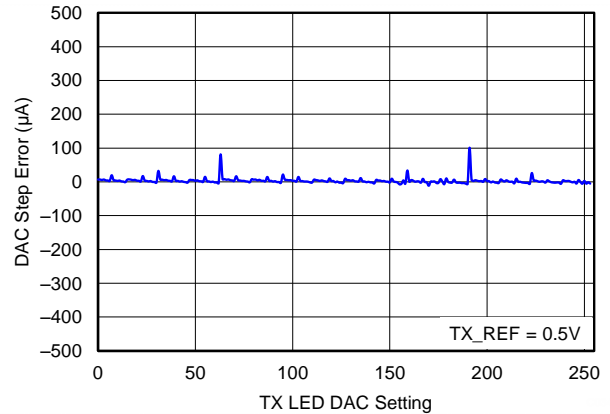

Figure 36. TRANSMITTER DAC CURRENT STEP ERROR (75 mA, Max)

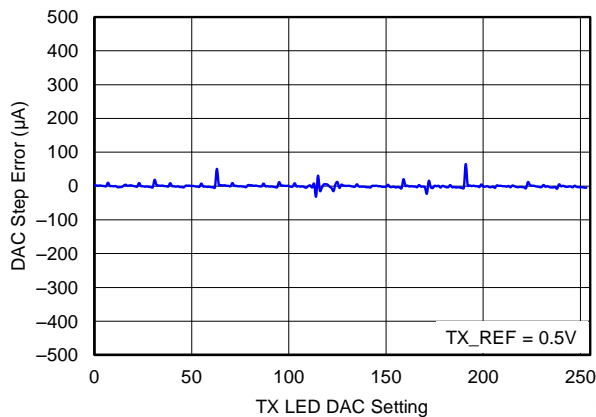

Figure 37. TRANSMITTER DAC CURRENT STEP ERROR (50 mA, Max)

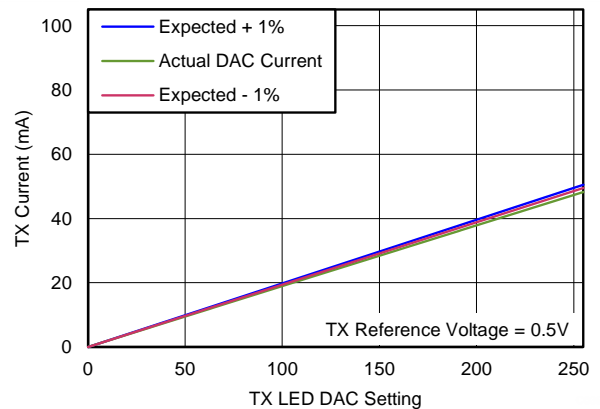

Figure 38. TRANSMITTER CURRENT LINEARITY (50-mA Range)

TYPICAL CHARACTERISTICS (continued)

At $T_A = +25^\circ\text{C}$, $RX_ANA_SUP = RX_DIG_SUP = 3.0\text{ V}$, $TX_CTRL_SUP = LED_DRV_SUP = 5\text{ V}$, and $f_{CLK} = 8\text{ MHz}$, unless otherwise noted.

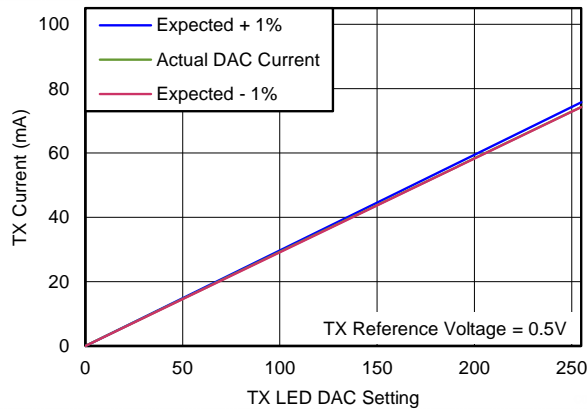

Figure 39. TRANSMITTER CURRENT LINEARITY (75-mA Range)

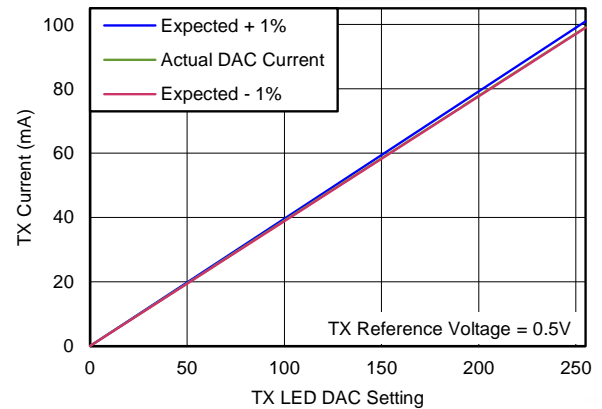

Figure 40. TRANSMITTER CURRENT LINEARITY (100-mA Range)

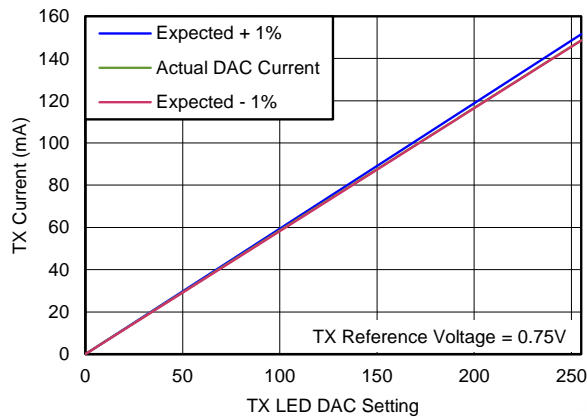

Figure 41. TRANSMITTER CURRENT LINEARITY (150-mA Range)

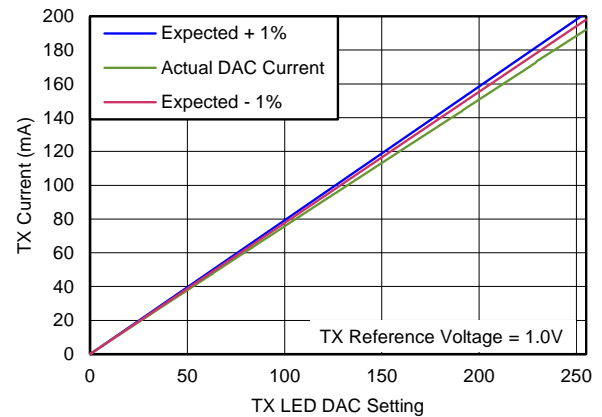

Figure 42. TRANSMITTER CURRENT LINEARITY (200-mA Range)

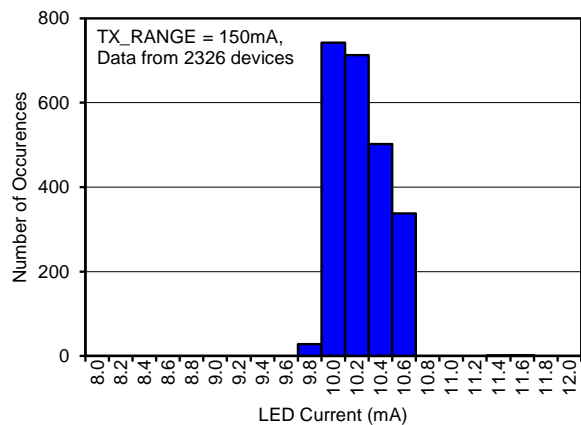

Figure 43. LED CURRENT WITH Tx DAC SETTING = 17 (10 mA)

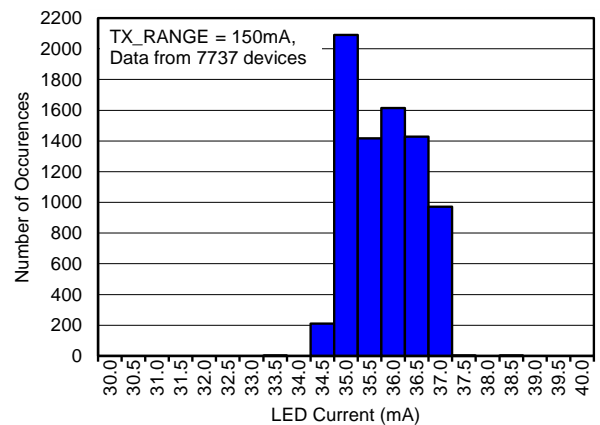

Figure 44. LED CURRENT WITH Tx DAC SETTING = 60 (35 mA)

TYPICAL CHARACTERISTICS (continued)

At $T_A = +25^\circ\text{C}$, $RX_ANA_SUP = RX_DIG_SUP = 3.0\text{ V}$, $TX_CTRL_SUP = LED_DRV_SUP = 5\text{ V}$, and $f_{CLK} = 8\text{ MHz}$, unless otherwise noted.

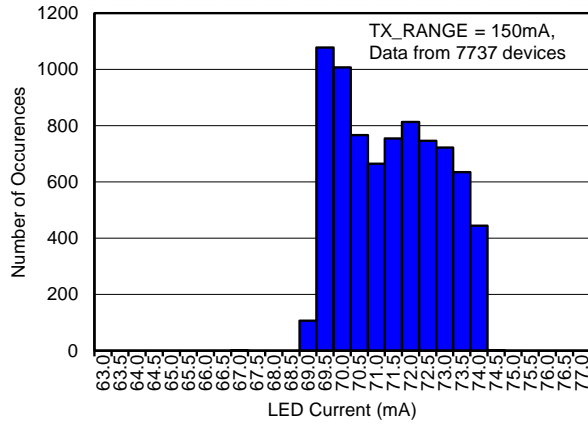

Figure 45. LED CURRENT WITH Tx DAC SETTING = 120 (70 mA)

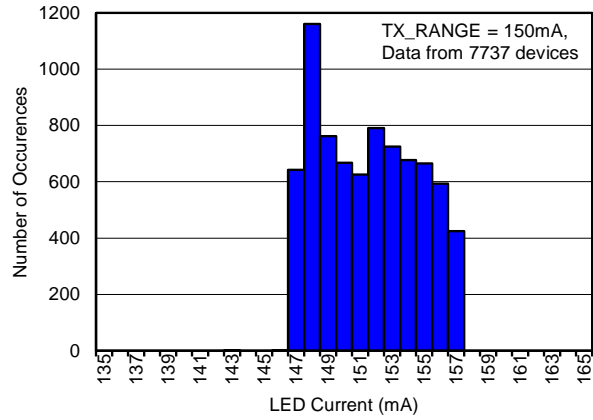

Figure 46. LED CURRENT WITH Tx DAC SETTING = 255 (150 mA)

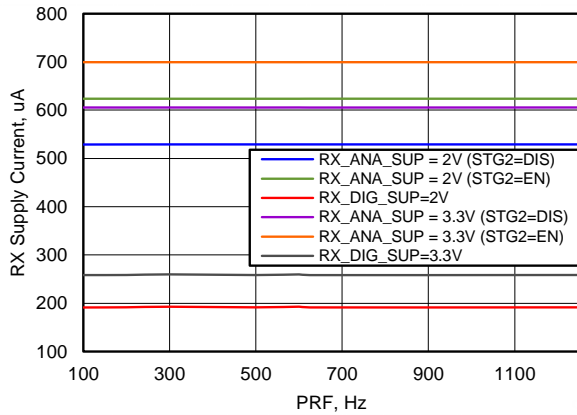

Figure 47. RECEIVER SUPPLIES vs PRF

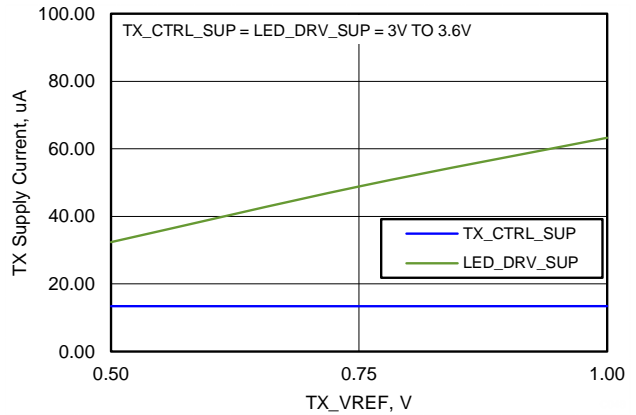

Figure 48. TRANSMITTER SUPPLIES vs TX_REF

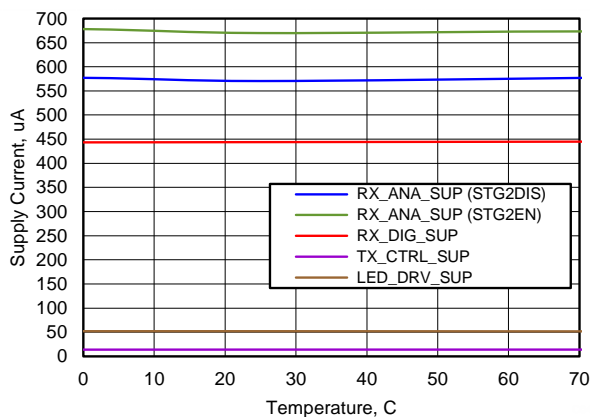

Figure 49. POWER SUPPLIES vs TEMPERATURE

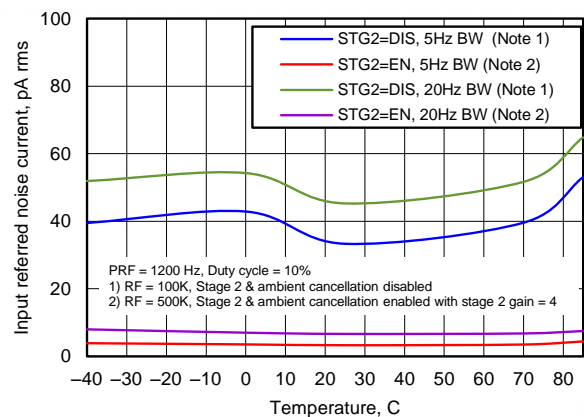

Figure 50. INPUT-REFERRED NOISE vs TEMPERATURE

TYPICAL CHARACTERISTICS (continued)

At $T_A = +25^\circ\text{C}$, $RX_ANA_SUP = RX_DIG_SUP = 3.0\text{ V}$, $TX_CTRL_SUP = LED_DRV_SUP = 5\text{ V}$, and $f_{CLK} = 8\text{ MHz}$, unless otherwise noted.

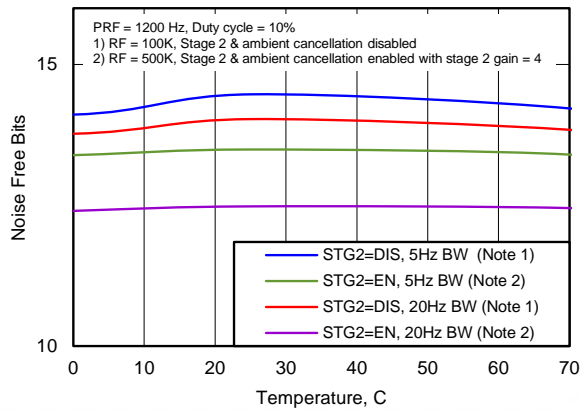

Figure 51. NOISE-FREE BITS vs TEMPERATURE

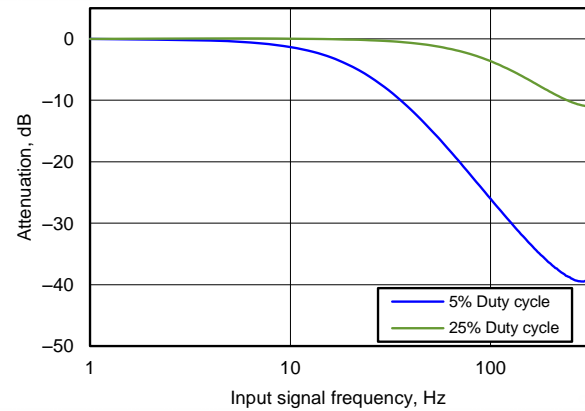

Figure 52. FILTER RESPONSE vs DUTY CYCLE

OVERVIEW

The AFE4490 is a complete analog front-end (AFE) solution targeted for pulse-oximeter applications. The device consists of a low-noise receiver channel, an LED transmit section, and diagnostics for sensor and LED fault detection. To ease clocking requirements and provide the low-jitter clock to the AFE, an oscillator is also integrated that functions from an external crystal. The device communicates to an external microcontroller or host processor using an SPI interface. Figure 53 shows a detailed block diagram for the AFE4490. The blocks are described in more detail in the following sections.

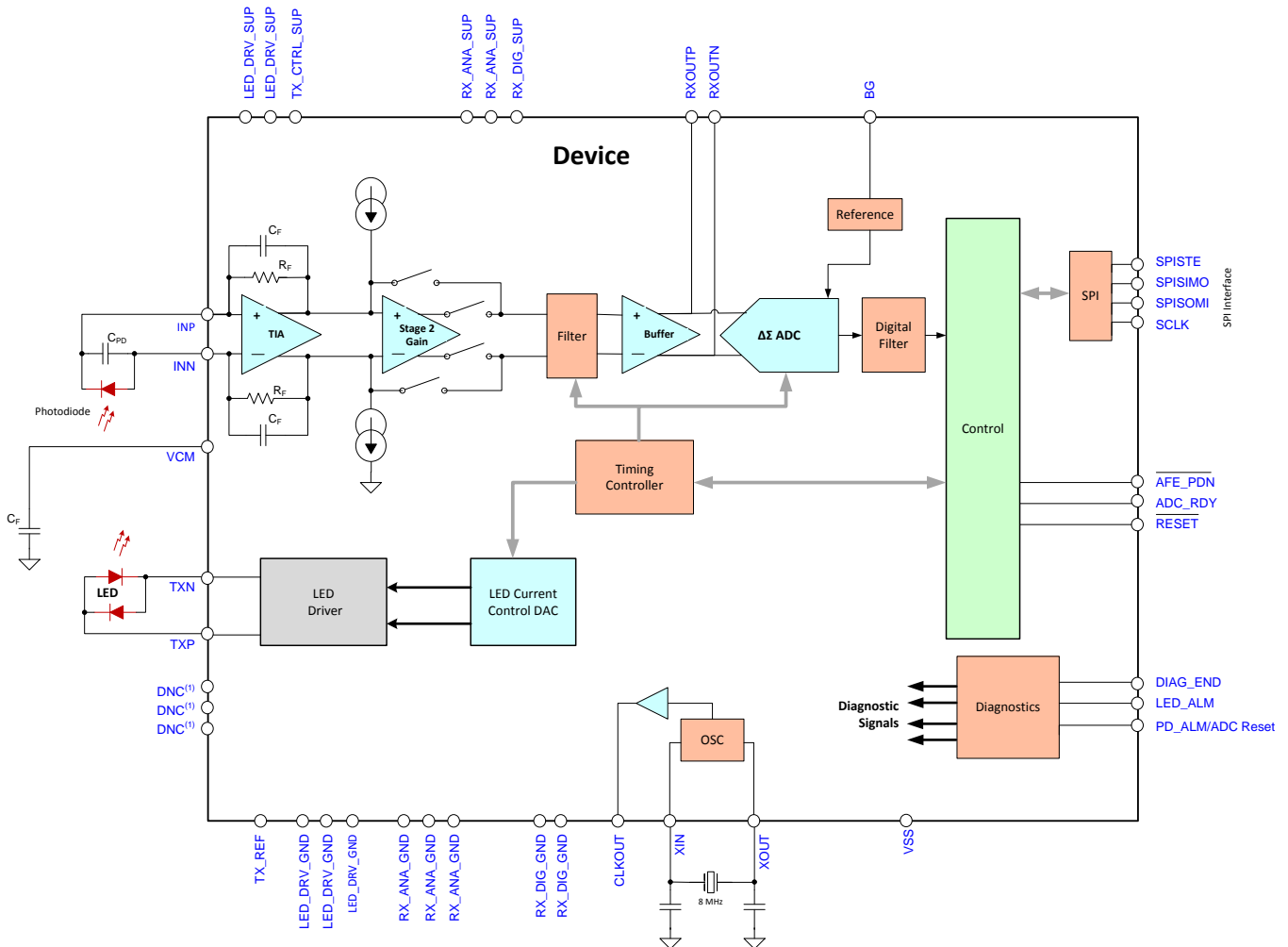

Figure 53. Detailed Block Diagram

RECEIVER CHANNEL

This section describes the receiver channel functionality.

Receiver Front-End

The receiver consists of a differential current-to-voltage (I-V) transimpedance amplifier that converts the input photodiode current into an appropriate voltage, as shown in Figure 54. The feedback resistor of the amplifier (R_F) is programmable to support a wide range of photodiode currents. Available R_F values include: 1 M Ω , 500 k Ω , 250 k Ω , 100 k Ω , 50 k Ω , 25 k Ω , and 10 k Ω .

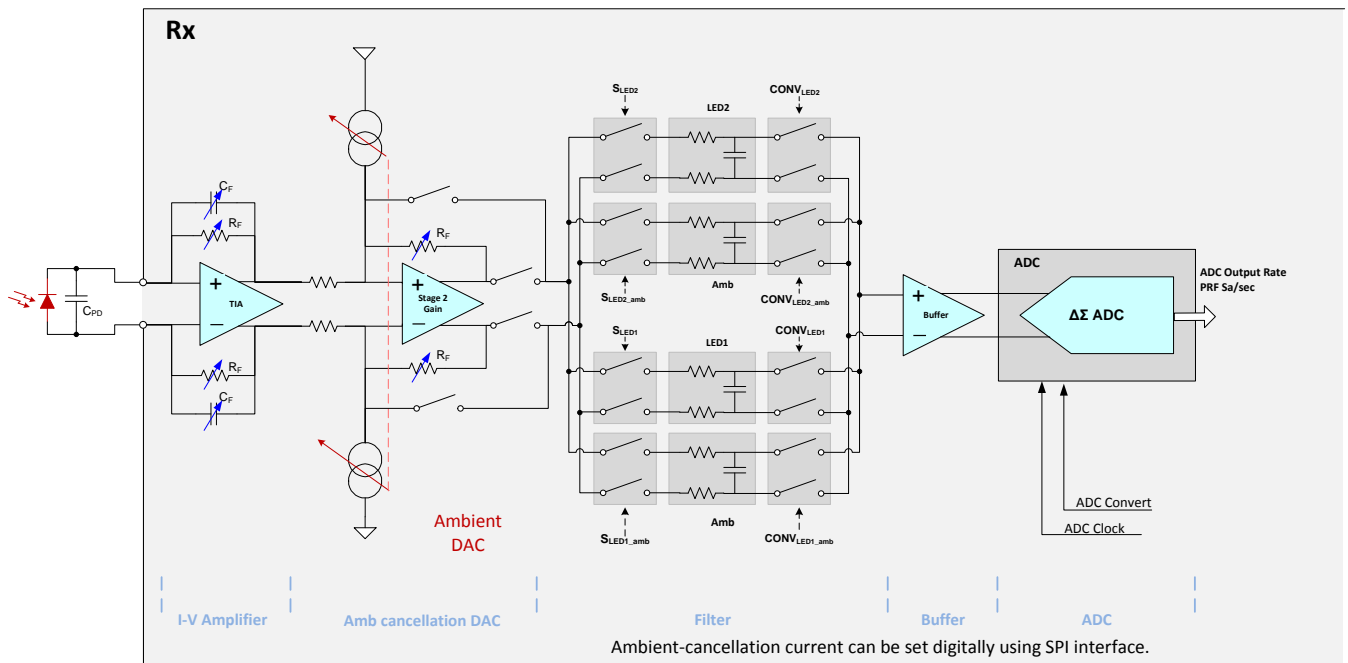

Figure 54. Receiver Front-End

The R_F amplifier and the feedback capacitor (C_F) form a low-pass filter for the input signal current. Always ensure that the low-pass filter has sufficiently high bandwidth (as shown by Equation 1) because the input current consists of pulses. For this reason, the feedback capacitor is also programmable. Available C_F values include: 5 pF, 10 pF, 25 pF, 50 pF, 100 pF, and 250 pF. Any combination of these capacitors can also be used.

$$R_F \times C_F \leq \frac{\text{Rx Sample Time}}{10} \quad (1)$$

The output voltage of the I-V amplifier includes the pleth component (the desired signal) and a component resulting from the ambient light leakage. The I-V amplifier is followed by the second stage, which consists of a current digital-to-analog converter (DAC) that sources the cancellation current and an amplifier that gains up the pleth component alone. The amplifier has five programmable gain settings: 1, 1.414, 2, 2.828, and 4. The gained-up pleth signal is then low-pass filtered (500-Hz bandwidth) and buffered before driving a 22-bit ADC. The current DAC has a cancellation current range of 10 μA with 10 steps (1 μA each). The DAC value can be digitally specified with the SPI interface.

The output of the ambient cancellation amplifier is separated into LED2 and LED1 channels. When LED2 is on, the amplifier output is filtered and sampled on capacitor C_R . Similarly, the LED1 signal is sampled on the C_{LED1} capacitor when LED1 is ON. In between the LED2 and LED1 pulses, the idle amplifier output is sampled to estimate the ambient signal on capacitors C_{LED2_amb} and C_{LED1_amb} .

The sampling duration is termed the *Rx sample time* and is programmable for each signal, independently. Sampling can start after the I-V amplifier output is stable (to account for LED and cable settling times). The Rx sample time is used for all dynamic range calculations; the minimum time supported is 50 μs .

A single, 22-bit ADC converts the sampled LED2, LED1, and ambient signals sequentially. Each conversion takes a maximum of 25% of the pulse repetition period (PRP) and provides a single digital code at the ADC output. As discussed in the [Receiver Timing](#) section, the conversions are staggered so that the LED2 conversion starts after the end of the LED2 sample phase, and so on. This configuration also means that the Rx sample time for each signal is no greater than 25% of the pulse repetition period.

Note that four data streams are available at the ADC output (LED2, LED1, ambient LED2, and ambient LED1) at the same rate as the pulse repetition frequency. The ADC is followed by a digital ambient subtraction block that additionally outputs the (LED2 – ambient LED2) and (LED1 – ambient LED1) data values.

Ambient Cancellation Scheme

The receiver provides digital samples corresponding to ambient duration. The host processor (external to the AFE) can use these ambient values to estimate the amount of ambient light leakage. The processor must then set the value of the ambient cancellation DAC using the SPI, as shown in [Figure 55](#).

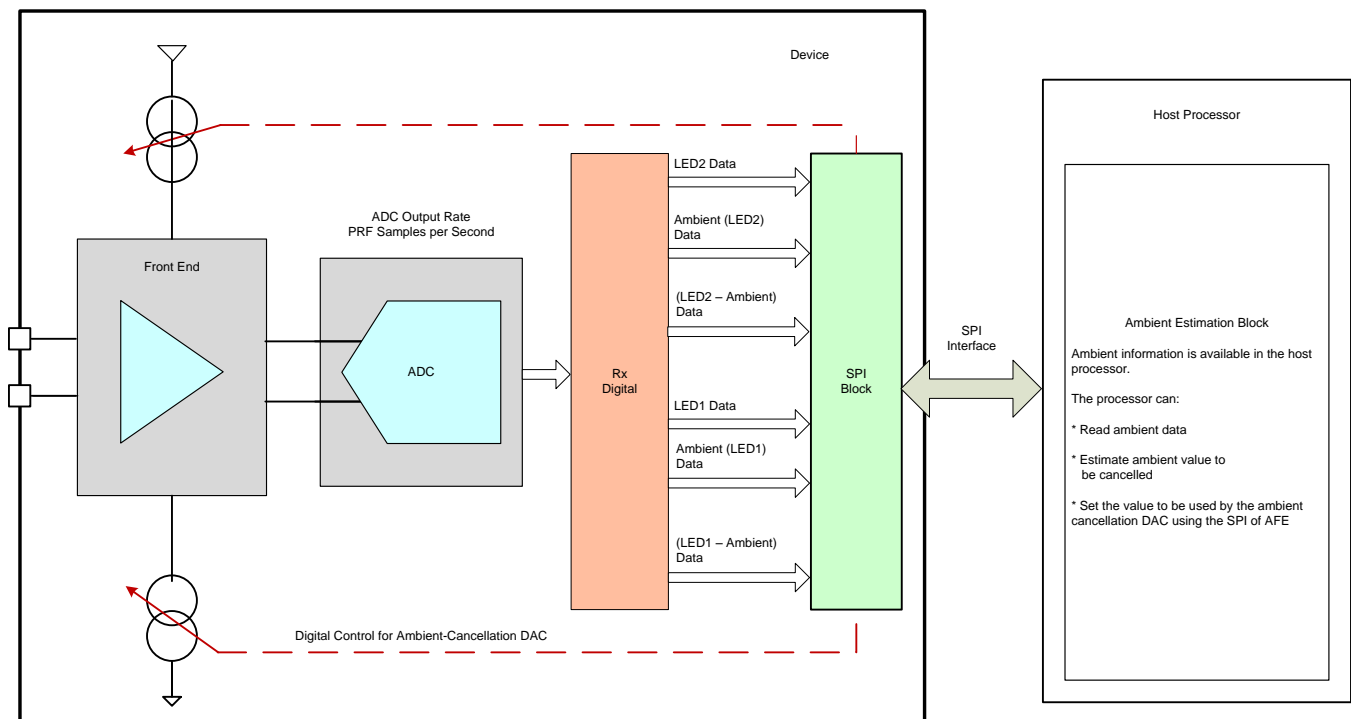

Figure 55. Ambient Cancellation Loop (Closed by the Host Processor)

Using the set value, the ambient cancellation stage subtracts the ambient component and gains up only the pleth component of the received signal, as shown in Figure 56.

The amplifier gain is programmable to 1, 1.5, 2, 3, and 4.

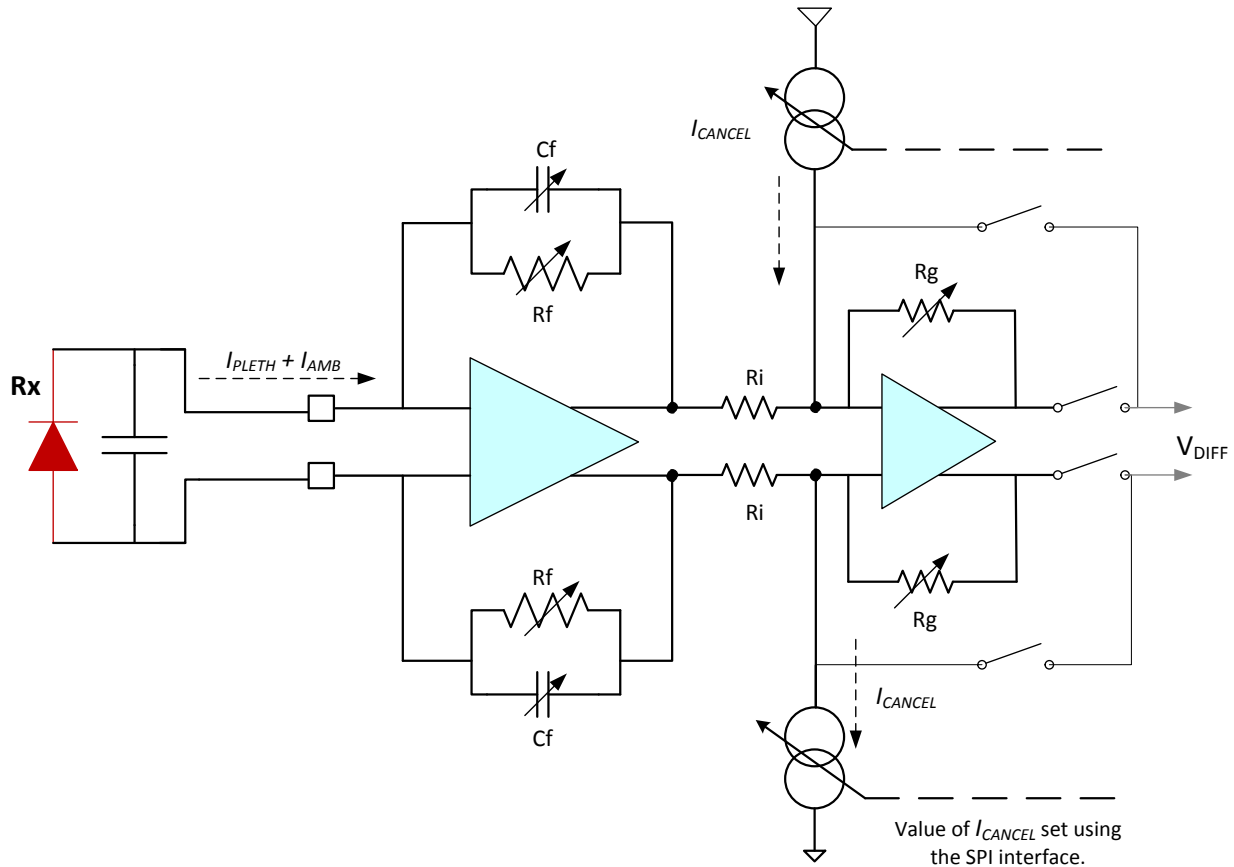

Figure 56. Front-End (I-V Amplifier and Cancellation Stage)

The differential output of the second stage is V_{DIFF} , as given by Equation 2:

$$V_{DIFF} = 2 \times \left[I_{PLETH} \times \frac{R_F}{R_I} + I_{AMB} \times \frac{R_F}{R_I} - I_{CANCEL} \right] \times R_G$$

where:

- $R_I = 100 \text{ k}\Omega$,
- I_{PLETH} = photodiode current pleth component,
- I_{AMB} = photodiode current ambient component, and
- I_{CANCEL} = the cancellation current DAC value (as estimated by the host processor).

(2)

Receiver Control Signals

LED2 sample phase (S_{LED2}): When this signal is high, the amplifier output corresponds to the LED2 on-time. The amplifier output is filtered and sampled into capacitor C_{LED2} . To avoid settling effects resulting from the LED or cable, program S_{LED2} to start after the LED turns on. This settling delay is programmable.

Ambient sample phase (S_{LED2_amb}): When this signal is high, the amplifier output corresponds to the LED2 off-time and can be used to estimate the ambient signal (for the LED2 phase). The amplifier output is filtered and sampled into capacitor C_{LED2_amb} .

LED1 sample phase (S_{LED1}): When this signal is high, the amplifier output corresponds to the LED1 on-time. The amplifier output is filtered and sampled into capacitor C_{LED1} . To avoid settling effects resulting from the LED or cable, program S_{LED1} to start after the LED turns on. This settling delay is programmable.

Ambient sample phase (S_{LED1_amb}): When this signal is high, the amplifier output corresponds to the LED1 off-time and can be used to estimate the ambient signal (for the LED1 phase). The amplifier output is filtered and sampled into capacitor C_{LED1_amb} .

LED2 convert phase ($CONV_{LED2}$): When this signal is high, the voltage sampled on C_{LED2} is buffered and applied to the ADC for conversion. The conversion time duration is always 25% of the pulse repetition period. At the end of the conversion, the ADC provides a single digital code corresponding to the LED2 sample.

Ambient convert phases ($CONV_{LED2_amb}$, $CONV_{LED1_amb}$): When this signal is high, the voltage sampled on C_{LED2_amb} (or C_{LED1_amb}) is buffered and applied to the ADC for conversion. The conversion time duration is always 25% of the pulse repetition period. At the end of the conversion, the ADC provides a single digital code corresponding to the ambient sample.

LED1 convert phase ($CONV_{LED1}$): When this signal is high, the voltage sampled on C_{LED1} is buffered and applied to the ADC for conversion. The conversion time duration is always 25% of the pulse repetition period. At the end of the conversion, the ADC provides a single digital code corresponding to the LED1 sample.

Receiver Timing

See [Figure 57](#) for a timing diagram detailing the control signals related to the LED on-time, Rx sample time, and the ADC conversion times for each channel.

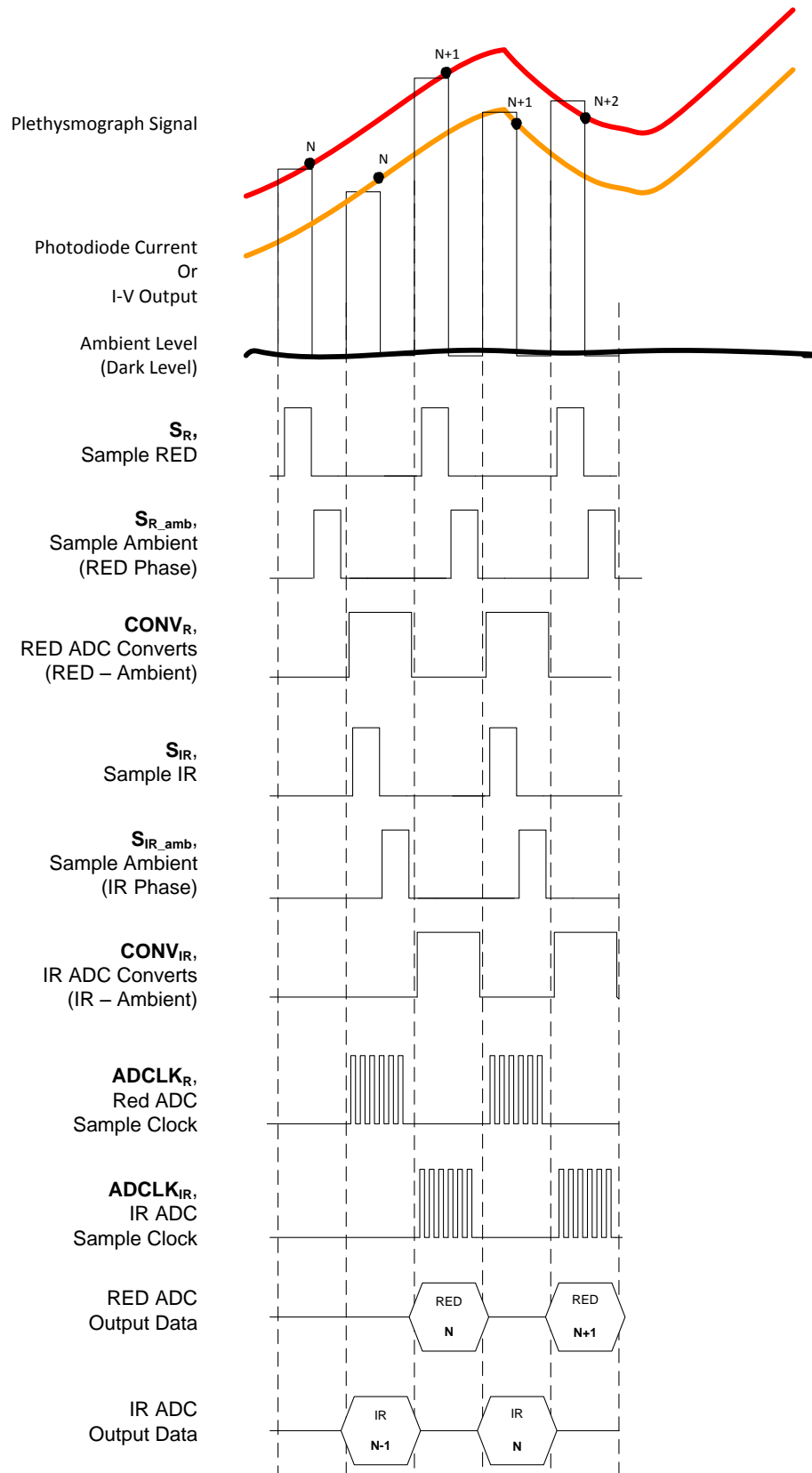

NOTE: Relationship to the AFE4490EVM is: LED1 = IR and LED2 = RED.

Figure 57. Rx Timing Diagram

CLOCKING AND TIMING SIGNAL GENERATION

The crystal oscillator generates a master clock signal using an external 8-MHz crystal. A divide-by-2 block converts the 8-MHz clock to 4 MHz, which is used by the AFE to operate the timer modules, ADC, and diagnostics. The 4-MHz clock is buffered and output from the AFE in order to clock an external microcontroller. The clocking functionality is shown in [Figure 58](#).

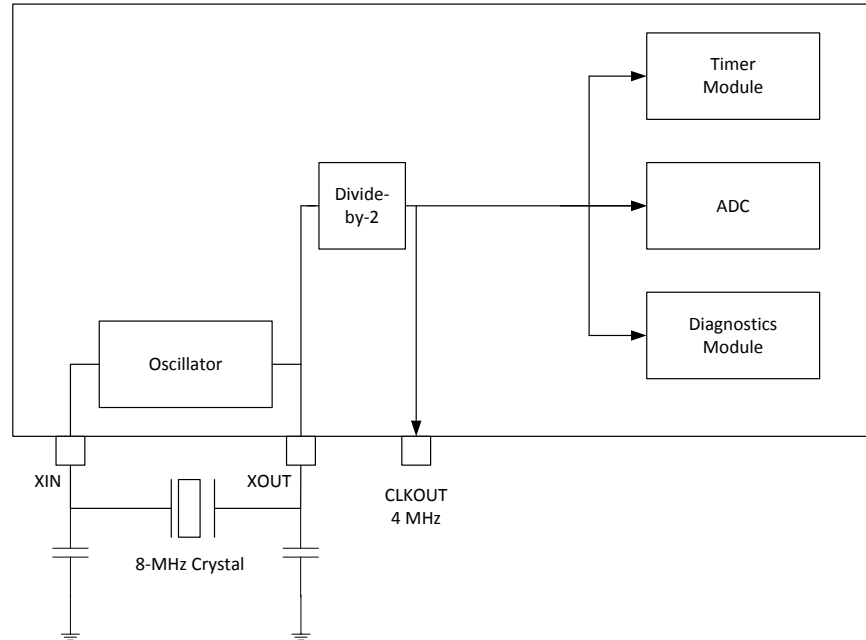
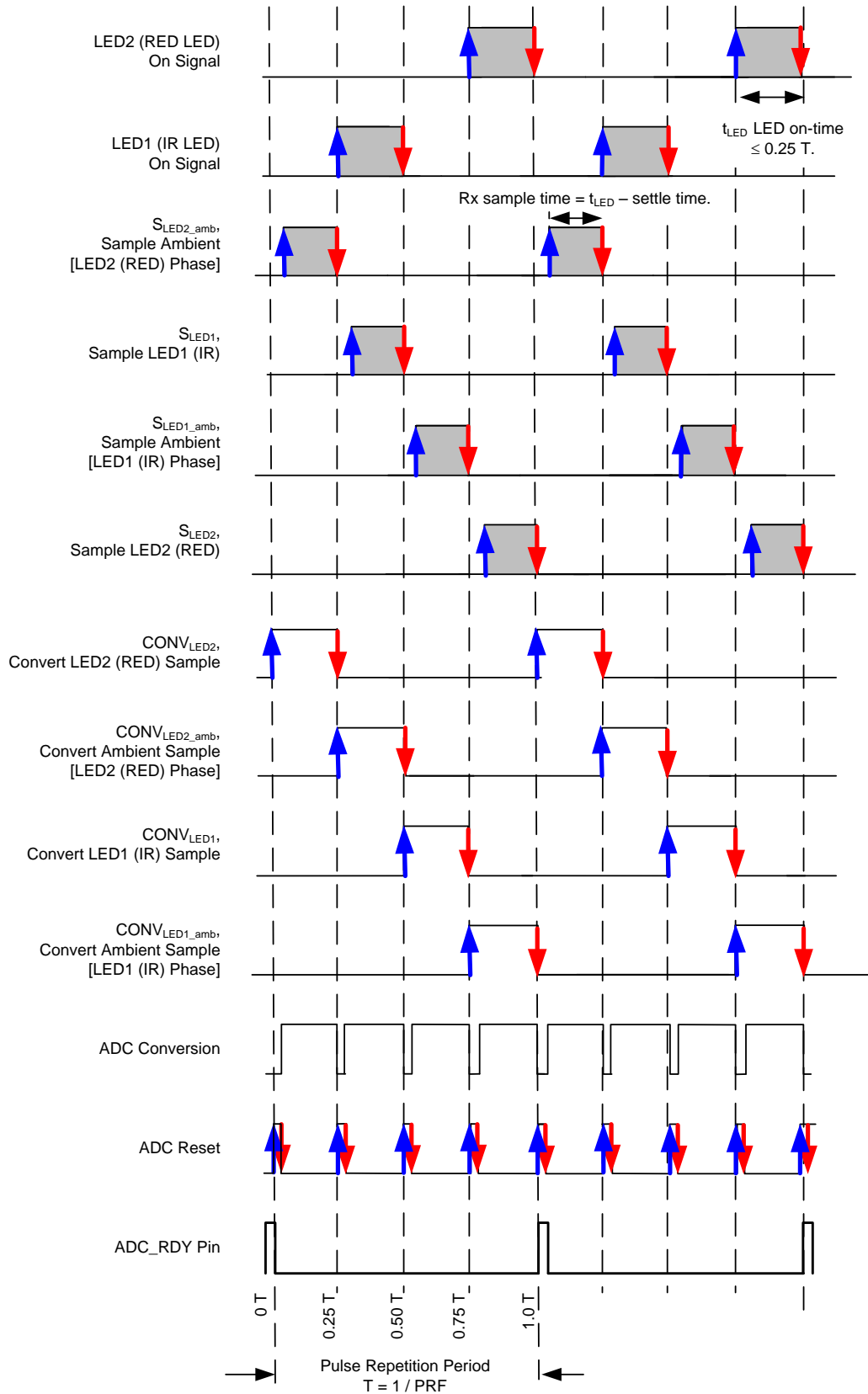

Figure 58. AFE Clocking

TIMER MODULE

See [Figure 59](#) for a timing diagram detailing the various timing edges that are programmable using the timer module. The rising and falling edge positions of 11 signals can be controlled. The module uses a single 16-bit counter (running off of the 4-MHz clock) to set the time-base.

All timing signals are set with reference to the pulse repetition period (PRP). Therefore, a dedicated compare register compares the 16-bit counter value with the reference value specified in the PRF register. Every time that the 16-bit counter value is equal to the reference value in the PRF register, the counter is reset to '0'.



NOTE: Programmable edges are shown in blue and red.

Figure 59. AFE Control Signals

For the 11 signals in [Figure 57](#), the start and stop edge positions are programmable with respect to the PRF period. Each signal uses a separate timer compare module that compares the counter value with preprogrammed reference values for the start and stop edges. All reference values can be set using the SPI interface.

When the counter value equals the start reference value, the output signal is set. When the counter value equals the stop reference value, the output signal is reset. [Figure 60](#) shows a diagram of the timer compare register. With a 4-MHz clock, the edge placement resolution is 0.25 μ s. The ADC conversion signal requires four pulses in each PRF clock period. The 11th timer compare register uses four sets of start and stop registers to control the ADC conversion signal.

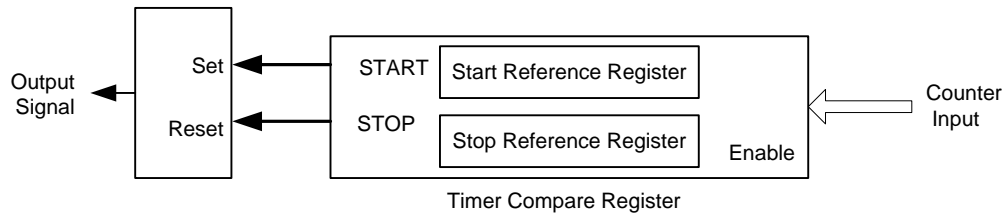

Figure 60. Compare Register

The ADC conversion signal requires four pulses in each PRF clock period. Timer compare register 11 uses four sets of start and stop registers to control the ADC conversion signal, as shown in [Figure 61](#).

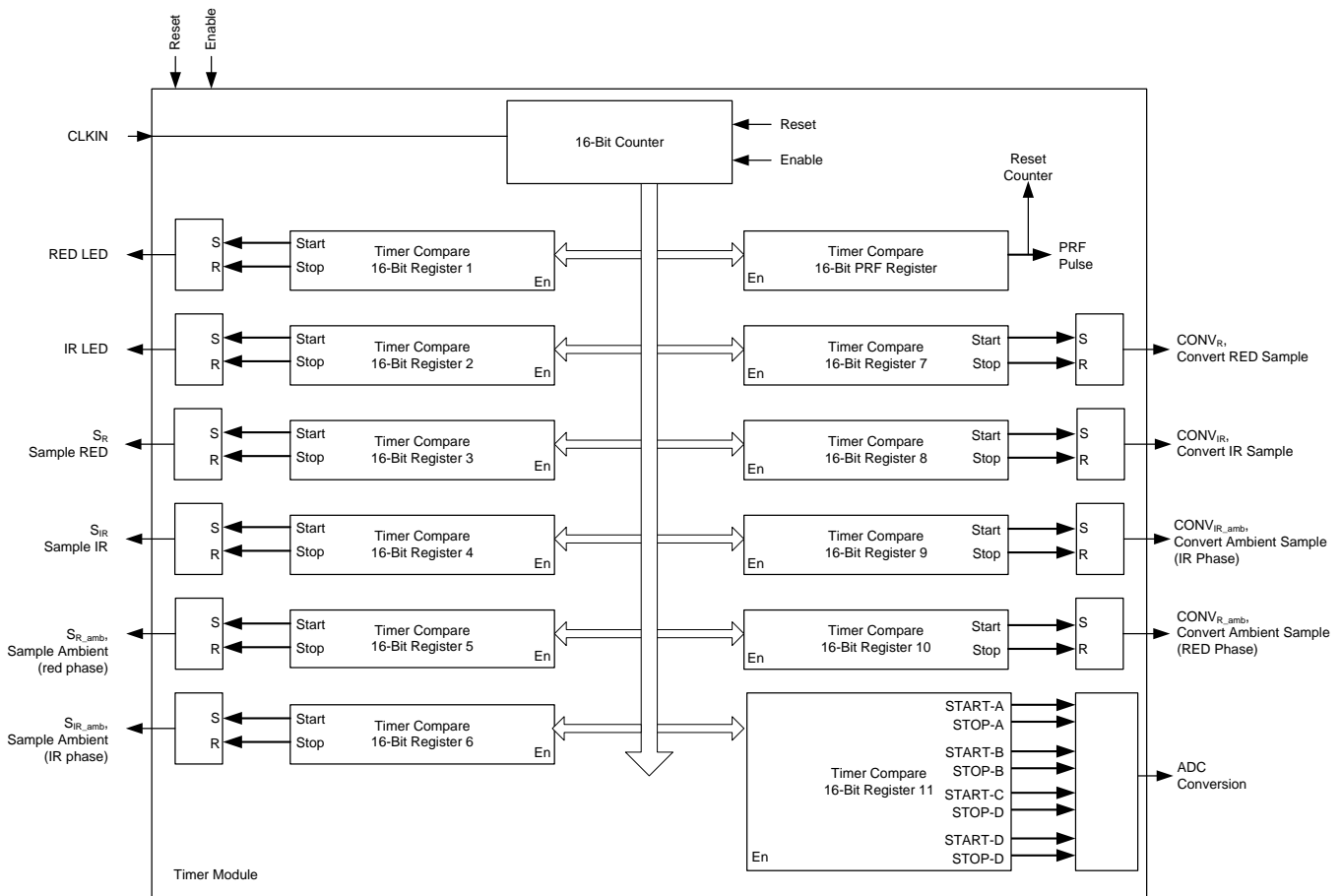

Figure 61. Timer Module

Using the Timer Module

The timer module registers can be used to program the start and end instants in units of 4-MHz clock cycles. These timing instants and the corresponding registers are listed in [Table 2](#).

Note that the device does not restrict the values in these registers; thus, the start and end edges can be positioned anywhere within the pulse repetition period. Care must be taken by the user to program suitable values in these registers to avoid overlapping the signals and to make sure none of the edges exceed the value programmed in the PRP register. Writing the same value in the start and end registers results in a pulse duration of one clock cycle. The following steps describe the timer sequencing configuration:

1. With respect to the start of the PRP period (indicated by timing instant t_0 in [Figure 62](#)), the sequence of conversions must be followed in order: convert LED2 → LED2 ambient → LED1 → LED1 ambient.
2. Also, starting from t_0 , the sequence of sampling instants must be staggered with respect to the respective conversions as follows: sample LED2 ambient → LED1 → LED1 ambient → LED2.
3. Finally, align the edges for the two LED pulses with the respective sampling instants.

Table 2. Clock Edge Mapping to SPI Registers

TIME INSTANT (See Figure 62 and Figure 63)	DESCRIPTION	CORRESPONDING REGISTER ADDRESS AND REGISTER BITS	EXAMPLE (Decimal)
t_0	Start of pulse repetition period	No register control	—
t_1	Start of sample LED2 pulse	Sample LED2 start count (bits 15-0 of register 01h)	4800
t_2	End of sample LED2 pulse	Sample LED2 end count (bits 15-0 of register 02h)	6399
t_3	Start of LED2 pulse	LED2 start count (bits 15-0 of register 03h)	4800
t_4	End of LED2 pulse	LED2 end count (bits 15-0 of register 04h)	6399
t_5	Start of sample LED2 ambient pulse	Sample ambient LED2 start count (bits 15-0 of register 05h)	0
t_6	End of sample LED2 ambient pulse	Sample ambient LED2 end count (bits 15-0 of register 06h)	1599
t_7	Start of sample LED1 pulse	Sample LED1 start count (bits 15-0 of register 07h)	1600
t_8	End of sample LED1 pulse	Sample LED1 end count (bits 15-0 of register 08h)	3199
t_9	Start of LED1 pulse	LED1 start count (bits 15-0 of register 09h)	1600
t_{10}	End of LED1 pulse	LED1 end count (bits 15-0 of register 0Ah)	3199
t_{11}	Start of sample LED1 ambient pulse	Sample ambient LED1 start count (bits 15-0 of register 0Bh)	3200
t_{12}	End of sample LED1 ambient pulse	Sample ambient LED1 end count (bits 15-0 of register 0Ch)	4700
t_{13}	Start of convert LED2 pulse	LED2 convert start count (bits 15-0 of register 0Dh)	0
t_{14}	End of convert LED2 pulse	LED2 convert end count (bits 15-0 of register 0Eh)	1599
t_{15}	Start of convert LED2 ambient pulse	LED2 ambient convert start count (bits 15-0 of register 0Fh)	1600
t_{16}	End of convert LED2 ambient pulse	LED2 ambient convert end count (bits 15-0 of register 10h)	3199
t_{17}	Start of convert LED1 pulse	LED1 convert start count (bits 15-0 of register 11h)	3200
t_{18}	End of convert LED1 pulse	LED1 convert end count (bits 15-0 of register 12h)	4799
t_{19}	Start of convert LED1 ambient pulse	LED1 ambient convert start count (bits 15-0 of register 13h)	4800
t_{20}	End of convert LED1 ambient pulse	LED1 ambient convert end count (bits 15-0 of register 14h)	6399
t_{21}	Start of first ADC conversion reset pulse	ADC reset 0 start count (bits 15-0 of register 15h)	0
t_{22}	End of first ADC conversion reset pulse	ADC reset 0 end count (bits 15-0 of register 16h)	0
t_{23}	Start of second ADC conversion reset pulse	ADC reset 1 start count (bits 15-0 of register 17h)	1600
t_{24}	End of second ADC conversion reset pulse	ADC reset 1 end count (bits 15-0 of register 18h)	1600
t_{25}	Start of third ADC conversion reset pulse	ADC reset 2 start count (bits 15-0 of register 19h)	3200
t_{26}	End of third ADC conversion reset pulse	ADC reset 2 end count (bits 15-0 of register 1Ah)	3200
t_{27}	Start of fourth ADC conversion reset pulse	ADC reset 3 start count (bits 15-0 of register 1Bh)	4800
t_{28}	End of fourth ADC conversion reset pulse	ADC reset 3 end count (bits 15-0 of register 1Ch)	4800
t_{29}	End of pulse repetition period	Pulse repetition period count (bits 15-0 of register 1Dh)	6399

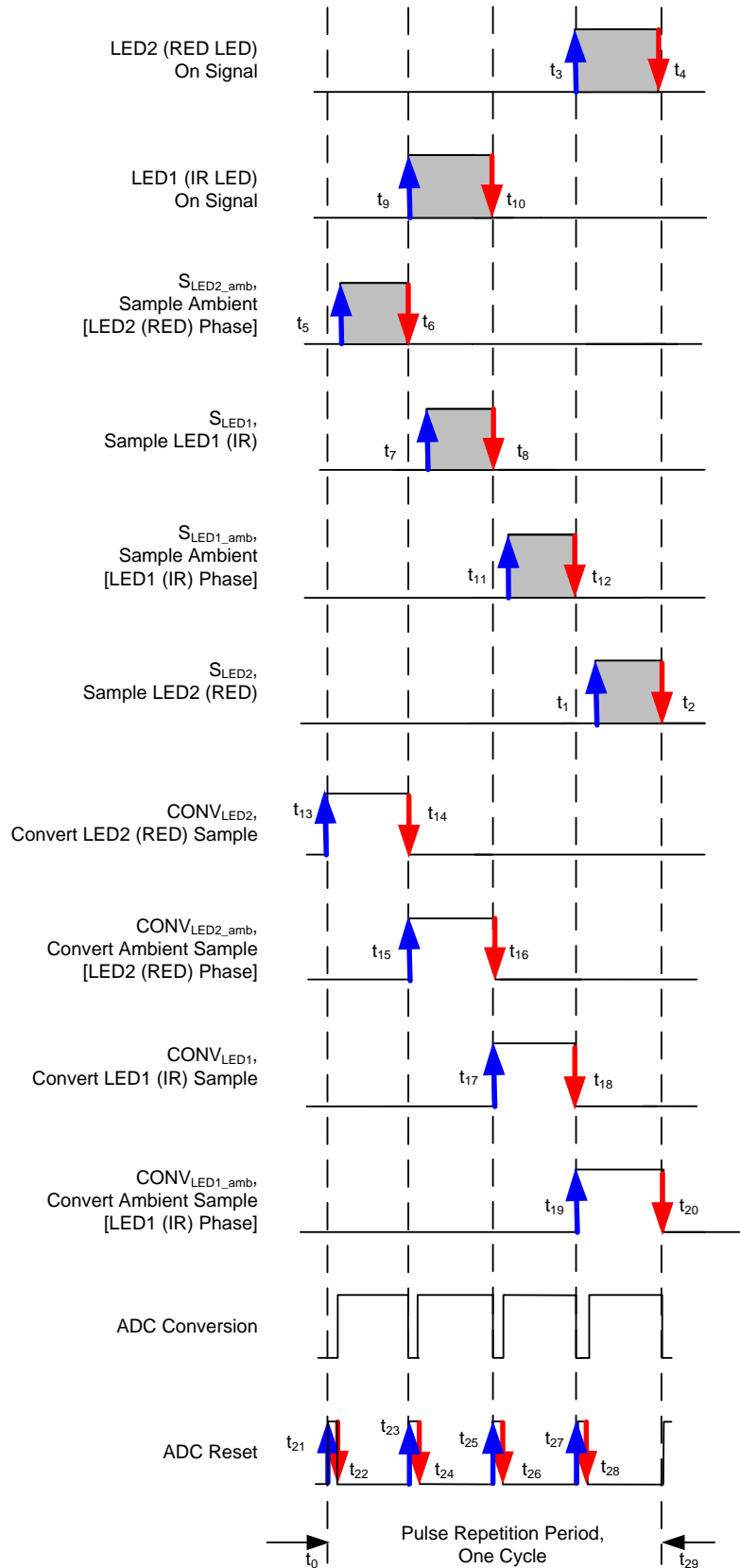

(1) RED = LED2, IR = LED1.

Figure 62. Programmable Clock Edges

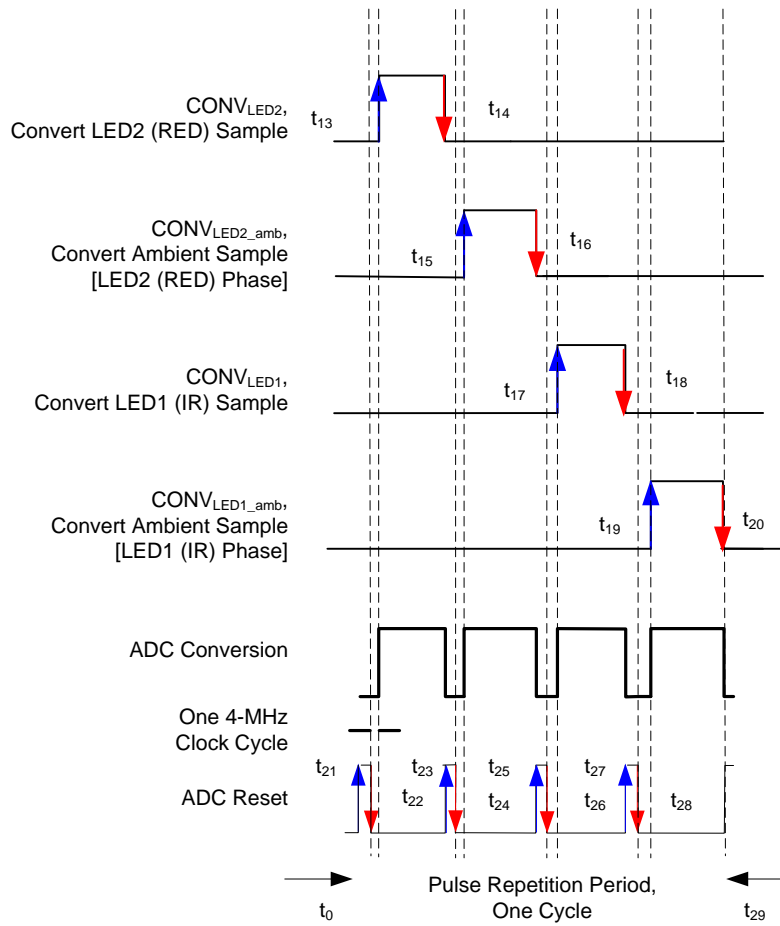

(1) RED = LED2, IR = LED1.

Figure 63. Relationship Between the ADC Reset and ADC Conversion Signals

ADC OPERATION AND AVERAGING MODULE

The ADC reset signal must be positioned at 25% intervals of the pulse repetition period (that is, 0%, 25%, 50%, and 75%). After the falling edge of the ADC reset signal, the ADC conversion phase starts (refer to [Figure 63](#)). Each ADC conversion takes 50 μ s.

There are two modes of operation: without averaging and with averaging. The averaging mode can average multiple ADC samples and reduce noise to improve dynamic range because the ADC conversion time is usually shorter than 25% of the pulse repetition period. [Figure 64](#) shows a diagram of the averaging module.

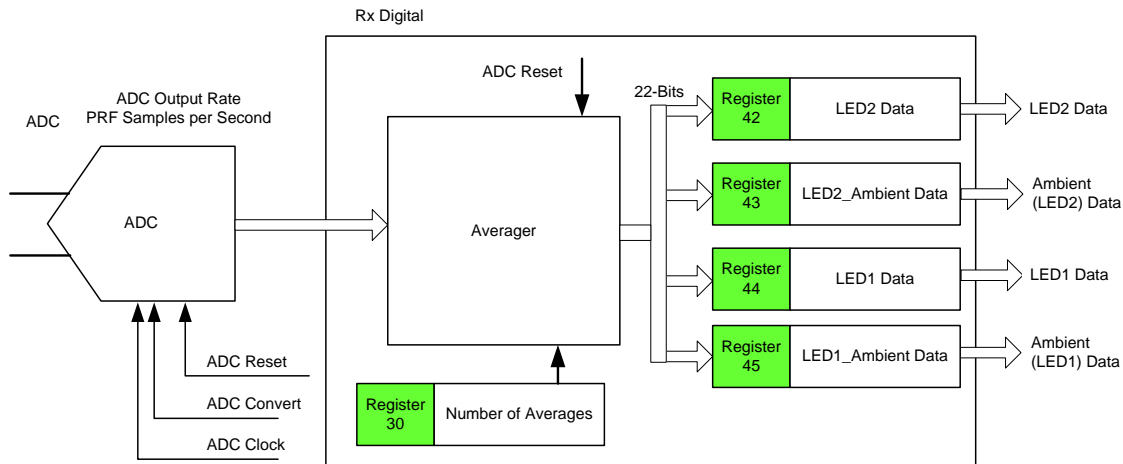

Figure 64. Averaging Module

Operation Without Averaging

In this mode, the ADC outputs a digital sample one time for every 50 μ s. At the next rising edge of the ADC reset signal, the first 22-bit conversion value is written into the result registers sequentially as follows (see [Figure 65](#)):

- At the 25% reset signal, the first 22-bit ADC sample is written to register 2Ah.
- At the 50% reset signal, the first 22-bit ADC sample is written to register 2Bh.
- At the 75% reset signal, the first 22-bit ADC sample is written to register 2Ch.
- At the next 0% reset signal, the first 22-bit ADC sample is written to register 2Dh. The contents of registers 2Ah and 2Bh are written to register 2Eh and the contents of registers 2Ch and 2Dh are written to register 2Fh.

At the rising edge of the ADC_RDY signal, the contents of all six result registers can be read out.

Operation With Averaging

In this mode, all ADC digital samples are accumulated and averaged after every 50 μ s. At the next rising edge of the ADC reset signal, the average value (22-bit) is written into the output registers sequentially as follows (see [Figure 66](#)):

- At the 25% reset signal, the averaged 22-bit word is written to register 2Ah.
- At the 50% reset signal, the averaged 22-bit word is written to register 2Bh.
- At the 75% reset signal, the averaged 22-bit word is written to register 2Ch.
- At the next 0% reset signal, the averaged 22-bit word is written to register 2Dh. The contents of registers 2Ah and 2Bh are written to register 2Eh and the contents of registers 2Ch and 2Dh are written to register 2Fh.

At the rising edge of the ADC_RDY signal, the contents of all six result registers can be read out.

The number of samples to be used per conversion phase is specified in the CONTROL1 register (NUMAV[7:0]). The user must specify the correct value for the number of averages, as described in Equation 3:

$$\text{NUMAV}[7:0] + 1 = \frac{0.25 \times \text{Pulse Repetition Period}}{50 \mu\text{s}} \quad (3)$$

When the number of averages is '0', the averaging is disabled and only one ADC sample is written to the result registers.

Note that the number of average conversions is limited by 25% of the PRF. For example, eight samples can be averaged with PRF = 625 Hz, and four samples can be averaged with PRF = 1250 Hz.

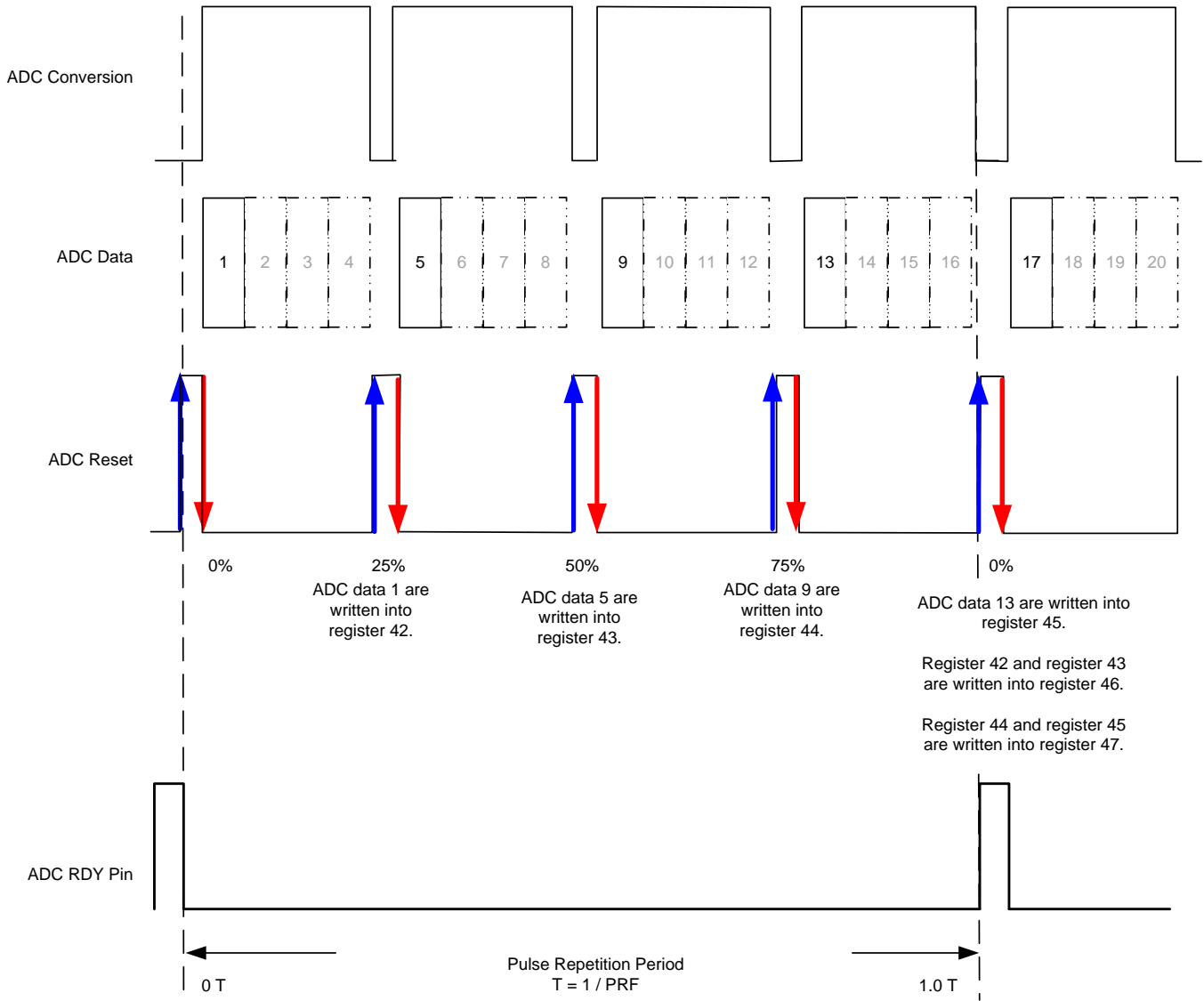
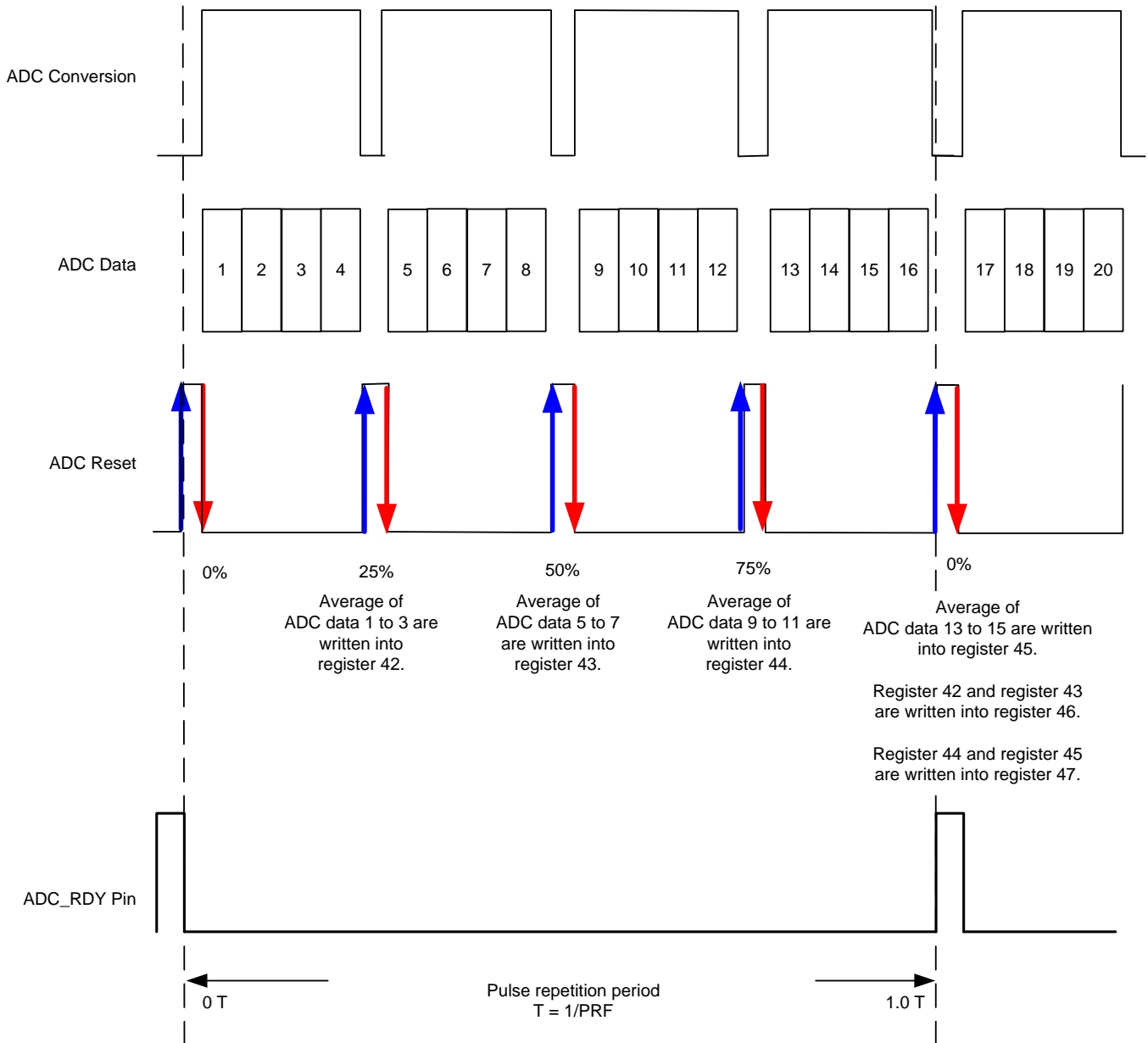

Figure 65. ADC Data Without Averaging (When Number of Averages = 0)



NOTE: Example is with three averages. The value of the NUMAVG[7:0] register bits = 2.

Figure 66. ADC Data with Averaging Enabled

AFE ANALOG OUTPUT MODE (ADC Bypass Mode)

The ADC bypass mode brings out the analog output voltage of the receiver front-end on two pins (RXOUTP, RXOUTN), around a common-mode voltage of approximately 0.9 V. In this mode, the internal ADC of the AFE4490 is disabled. Figure 67 shows a block diagram of this mode.

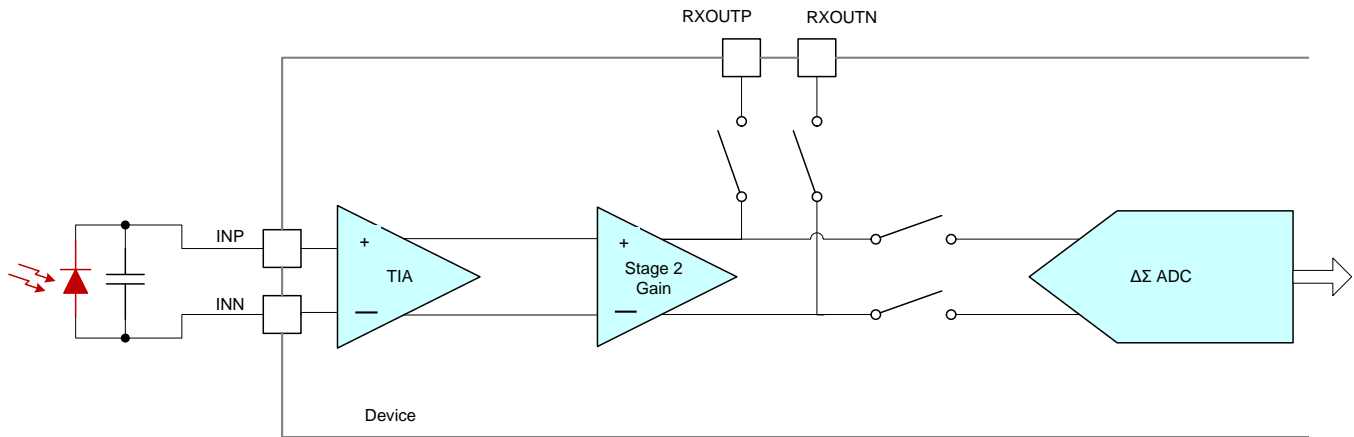

Figure 67. AFE4490 Set to ADC Bypass Mode

In ADC bypass mode, one of the internal clocks (ADC_Reset) can be brought out on the PD_ALM pin, as shown in Figure 68. This signal can be used to convert each of the four phases (within every pulse repetition period). Additionally, the ADC_RDY signal can be used to synchronize the external ADC with the AFE. See Figure 69 for the timing of this mode.

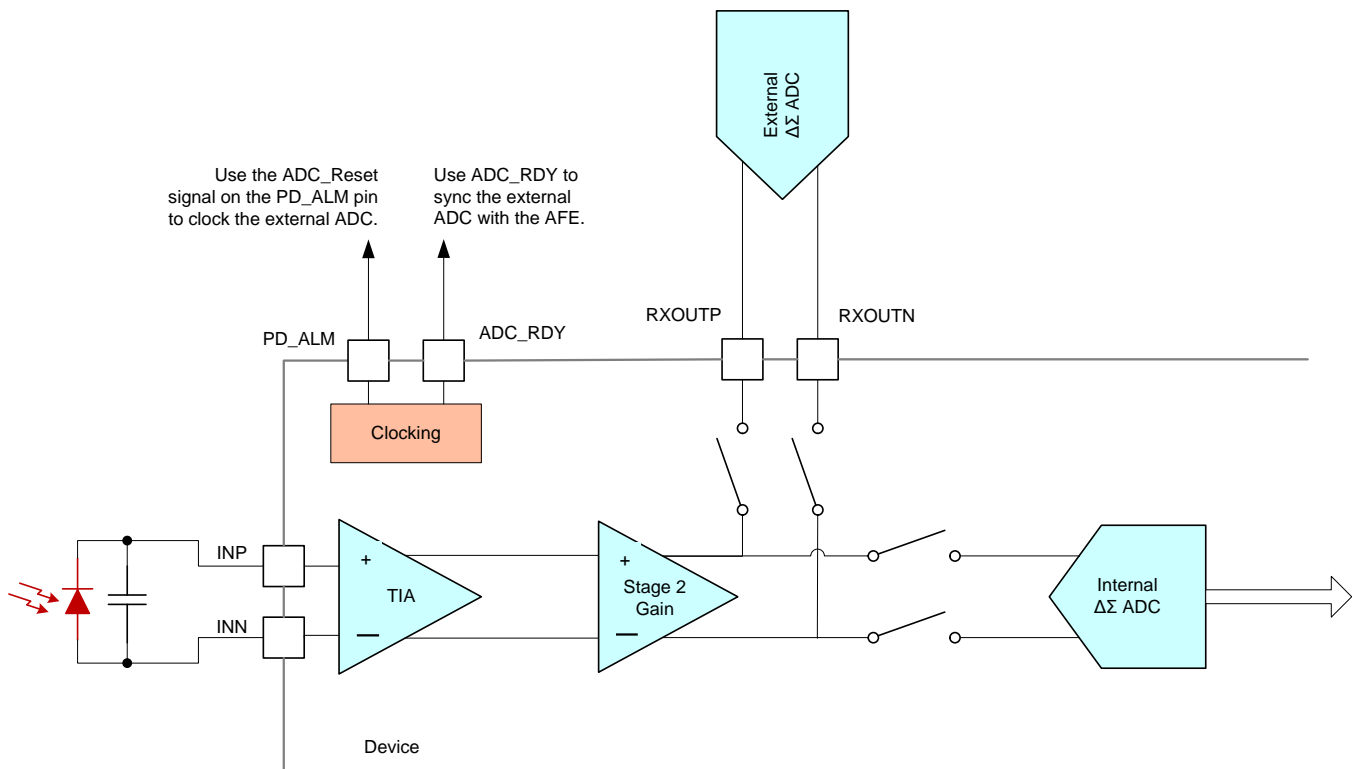
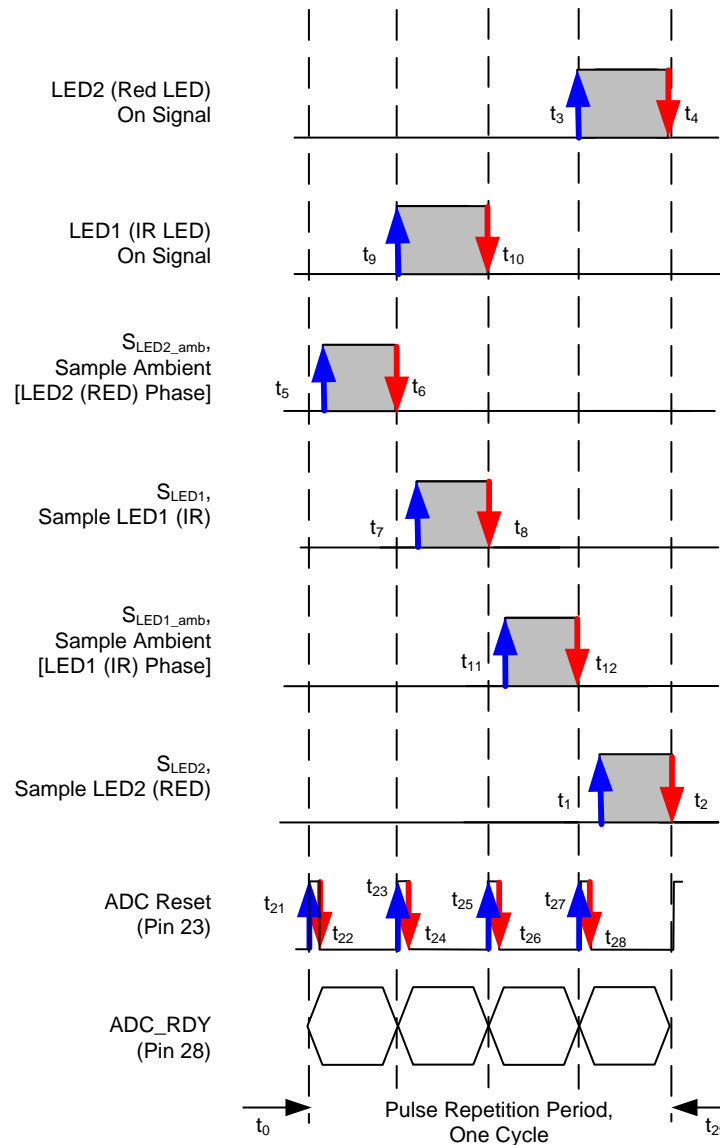

Figure 68. AFE4490 in ADC Bypass Mode with ADC_Reset to PD_ALM Pin



NOTE: RED = LED2, IR = LED1.

Figure 69. AFE4490 Analog Output Mode (ADC Bypass) Timing Diagram

In ADC bypass mode, the ADC reset signal can be used to start conversions with the external ADC. Use registers 15h through 1Ch to position the ADC reset signal edges appropriately. Also, use the CLKALMPIN[2:0] bits on the PD_ALM pin register bit to bring out the ADC reset signal to the PD_ALM pin. ADC_RDY can be used to indicate the start of the pulse repetition period to the external ADC.

RECEIVER SUBSYSTEM POWER PATH

The block diagram in [Figure 70](#) shows the AFE4490 Rx subsystem power routing.

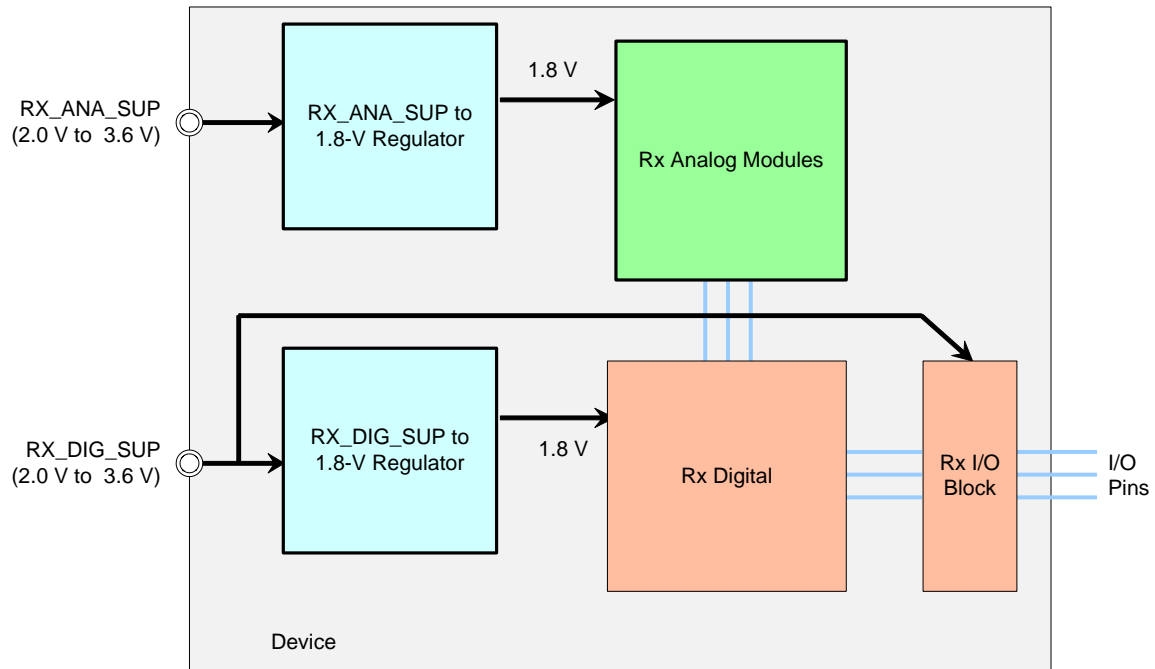

Figure 70. Receive Subsystem Power Routing

TRANSMIT SECTION

The transmit section integrates the LED driver and the LED current control section with 8-bit resolution. This integration is designed to meet the specified dynamic range (based on a 1-sigma LED current noise).

The LED2 and LED1 reference currents can be independently set. The current source (I_{LED}) locally regulates and ensures that the actual LED current tracks the specified reference.

Two LED driver schemes are supported:

- An H-bridge drive for a two-terminal back-to-back LED package, as shown in [Figure 71](#). The minimum H-bridge supply voltage must be $2.5\text{ V} + (\text{maximum voltage drop across the LED})$.
- A push-pull drive for a three-terminal LED package; see [Figure 72](#). The minimum external supply voltage = $2.0\text{ V} + (\text{maximum voltage drop across the LED})$. This value is the nominal value and depends on the registry LED current settings (refer to the LED_RANGE[1:0] bits in the LEDCNTRL register).

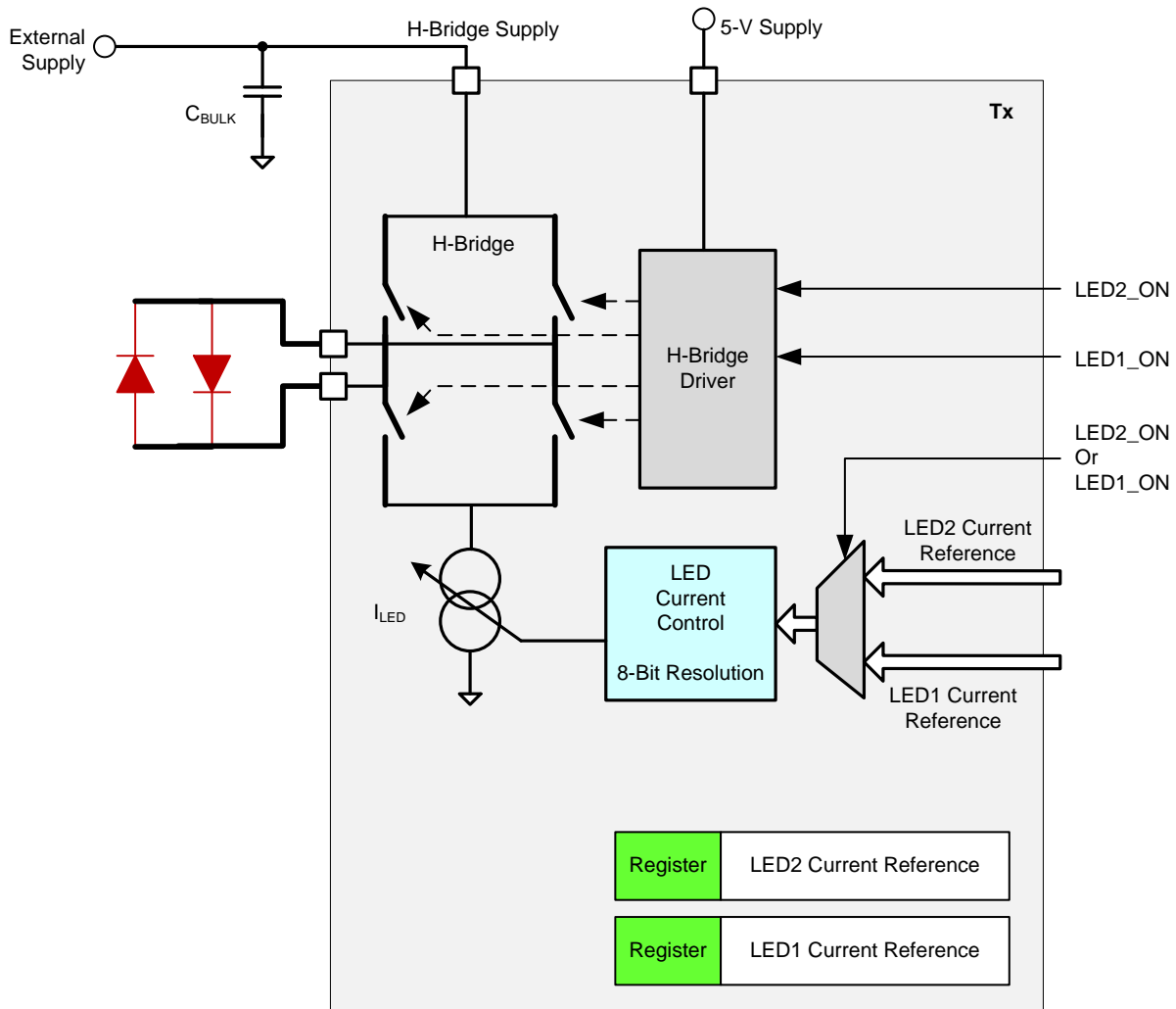

Figure 71. Transmit: H-Bridge Drive

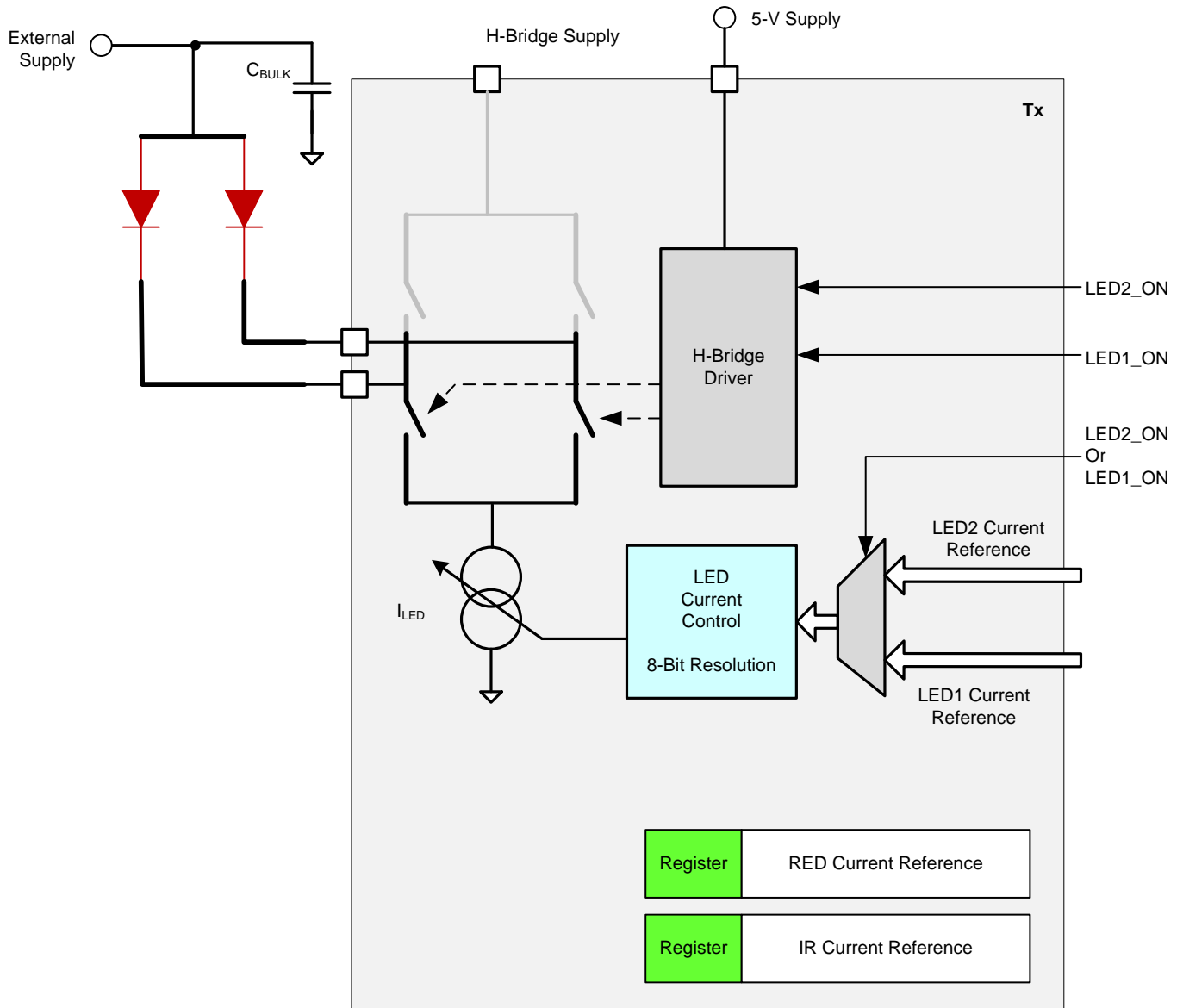

Figure 72. Transmit: Push-Pull LED Drive for Common Anode LED Configuration

Transmitter Power Path

The block diagram in [Figure 73](#) shows the AFE4490 Tx subsystem power routing.

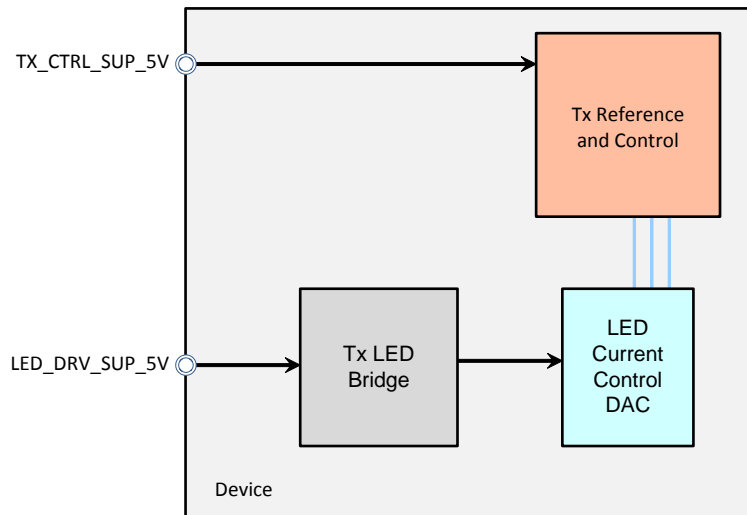

Figure 73. Transmit Subsystem Power Routing

LED Power Reduction During Periods of Inactivity

The diagram in [Figure 74](#) shows how LED bias current passes 50 μA whenever LED_ON occurs. In order to minimize power consumption in periods of inactivity, the LED_ON control must be turned off. Furthermore, the TIMEREN bit in the CONTROL1 register should be disabled by setting the value to '0'.

Note that depending on the LEDs used, the LED may sometimes appear dimly lit even when the LED current is set to 0 mA. This appearance is because of the switching leakage currents (as shown in [Figure 74](#)) inherent to the timer function. The dimmed appearance does not effect the ambient light level measurement because during the ambient cycle, LED_ON is turned off for the duration of the ambient measurement.

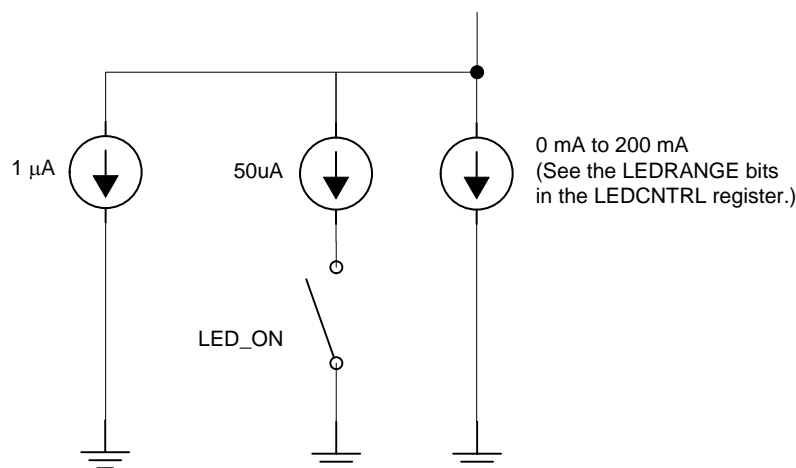

Figure 74. LED Bias Current

DIAGNOSTICS

The device includes diagnostics to detect open or short conditions of the LED and photosensor, LED current profile feedback, and cable on or off detection.

Photodiode-Side Fault Detection

Figure 75 shows the diagnostic for the photodiode-side fault detection.

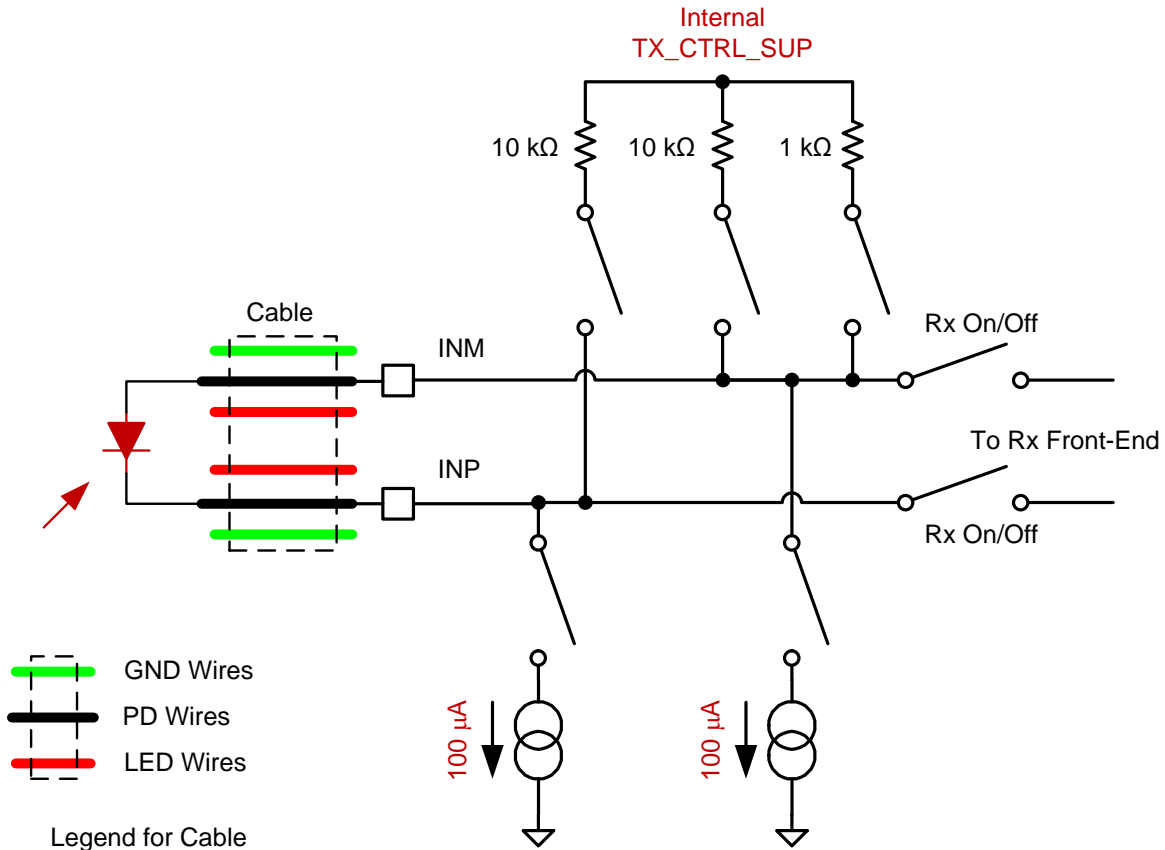

Figure 75. Photodiode Diagnostic

Transmitter-Side Fault Detection

Figure 76 shows the diagnostic for the transmitter-side fault detection.

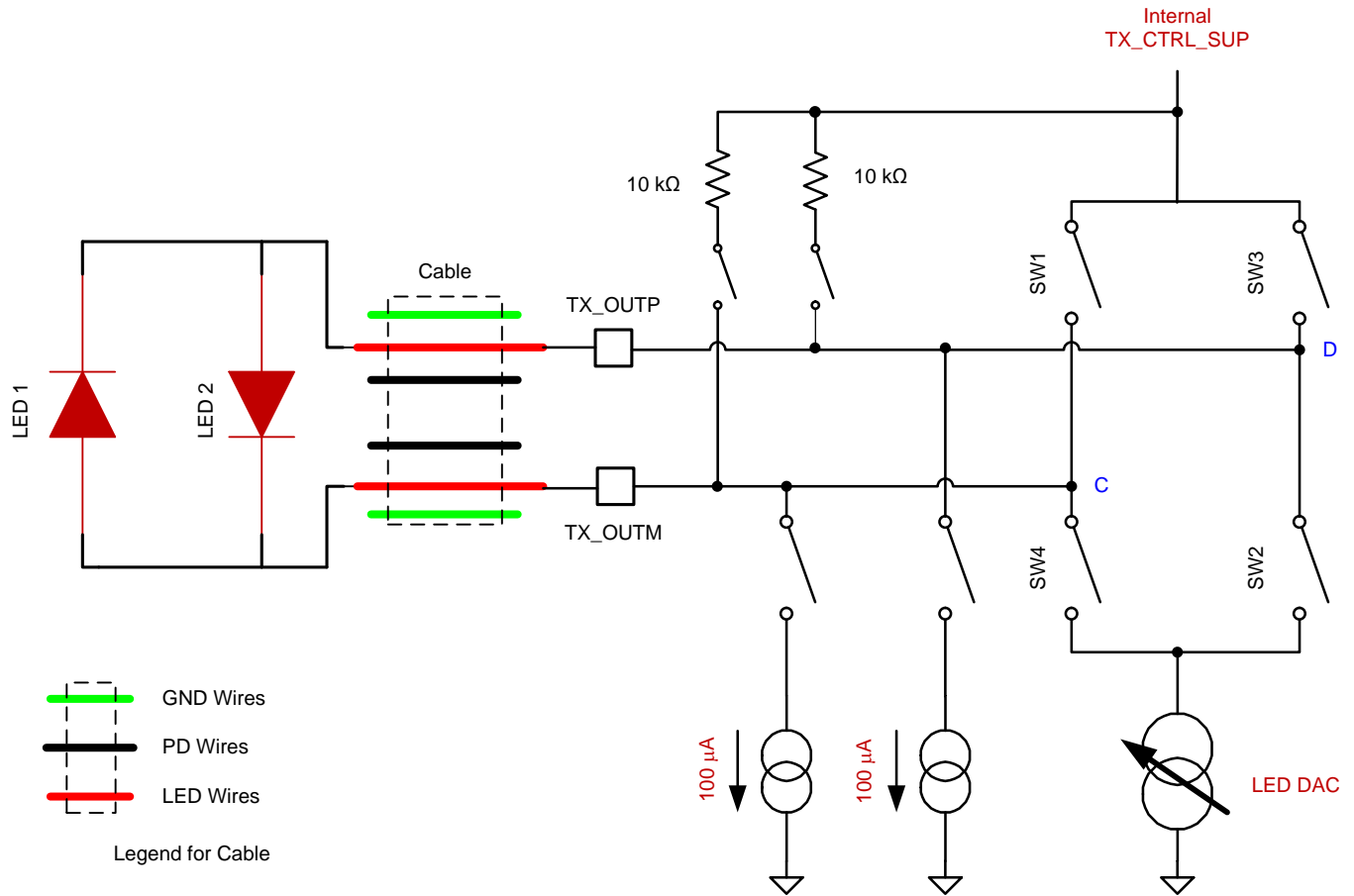

Figure 76. Transmitter Diagnostic

Diagnostics Module

The diagnostics module, when enabled, checks for nine types of faults sequentially. The results of all faults are latched in 11 separate flags. At the end of the sequence, the state of the 11 flags are combined to generate two interrupt signals: PD_ALM for photodiode-related faults and LED_ALM for transmit-related faults. The status of all flags can also be read using the SPI interface. Table 3 details each fault and flag used. Note that the diagnostics module requires all AFE blocks to be enabled in order to function reliably.

Table 3. Fault and Flag Diagnostics⁽¹⁾

MODULE	SEQ.	FAULT	FLAG1	FLAG2	FLAG3	FLAG4	FLAG5	FLAG6	FLAG7	FLAG8	FLAG9	FLAG10	FLAG11
—	—	No fault	0	0	0	0	0	0	0	0	0	0	0
PD	1	Rx INP cable shorted to LED cable	1										
	2	Rx INM cable shorted to LED cable		1									
	3	Rx INP cable shorted to GND cable			1								
	4	Rx INM cable shorted to GND cable				1							
	5	PD open or shorted					1	1					
LED	6	Tx OUTM line shorted to GND cable							1				
	7	Tx OUTP line shorted to GND cable								1			
	8	LED open or shorted									1	1	
	9	LED open or shorted											1

(1) Resistances below 10 kΩ are considered to be shorted.

Figure 77 shows the timing for the diagnostic function.

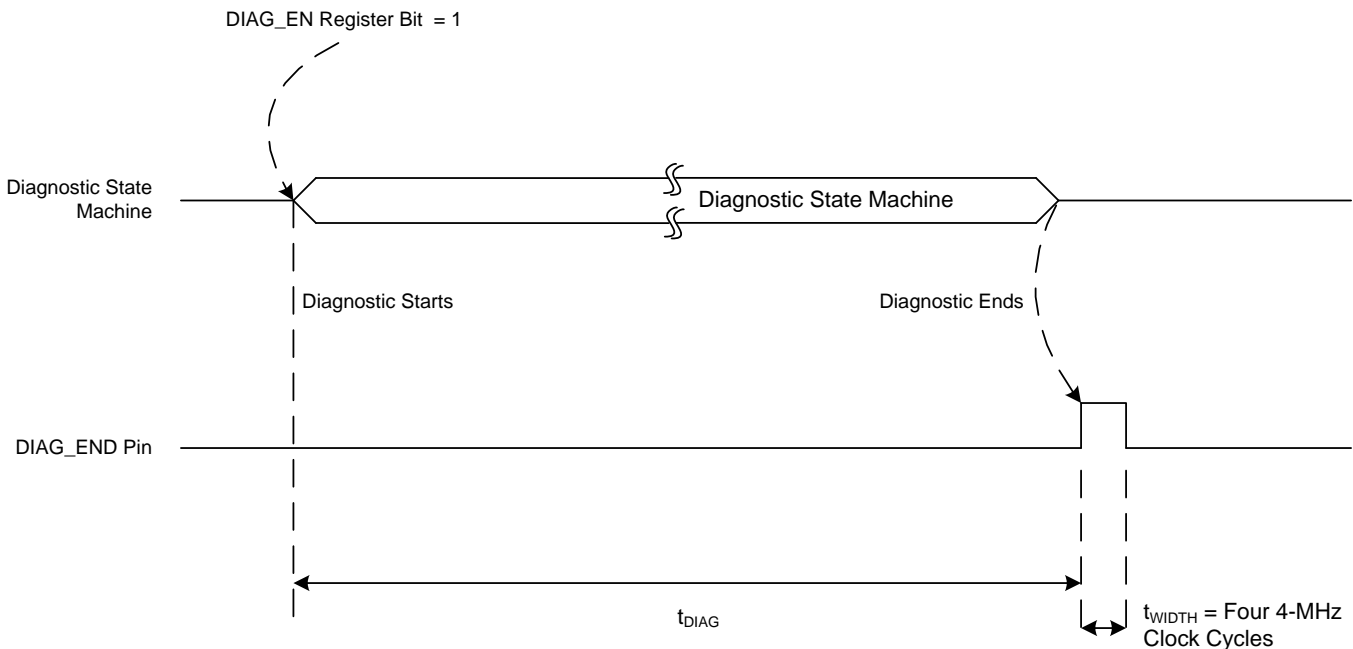

Figure 77. Diagnostic Timing Diagram

By default, the diagnostic function takes $t_{DIAG} = 8$ ms to complete after the DIAG_EN register bit is enabled. By setting the EN_SLOW_DIAG register bit (CONTROL2 register, bit D8) the diagnostic time can be increased to 16 ms.

SERIAL PROGRAMMING INTERFACE

The SPI-compatible serial interface consists of four signals: SCLK (serial clock), SPISOMI (serial interface data output), SPISIMO (serial interface data input), and SPISTE (serial interface enable).

The serial clock (SCLK) is the serial peripheral interface (SPI) serial clock. SCLK shifts in commands and shifts out data from the device. SCLK features a Schmitt-triggered input and clocks data out on SPISOMI. Data are clocked in on the SPISIMO pin. Even though the input has hysteresis, TI recommends keeping SCLK as clean as possible to prevent glitches from accidentally shifting the data. When the serial interface is idle, hold SCLK low.

The SPISOMI (SPI serial out master in) pin is used with SCLK to clock out the AFE4490 data. The SPISIMO (SPI serial in master out) pin is used with SCLK to clock in data to the AFE4490. The SPISTE (SPI serial interface enable) pin enables the serial interface to clock data on the SPISIMO pin in to the device.

READING AND WRITING DATA

The device has a set of internal registers that can be accessed by the serial programming interface formed by the SPISTE, SCLK, SPISIMO, and SPISOMI pins.

Writing Data

When SPISTE is low,

- Serially shifting bits into the device is enabled.
- Serial data (on the SPISIMO pin) are latched at every SCLK rising edge.
- The serial data are loaded into the register at every 32nd SCLK rising edge.

In case the word length exceeds a multiple of 32 bits, the excess bits are ignored. Data can be loaded in multiples of 32-bit words within a single active SPISTE pulse. The first eight bits form the register address and the remaining 24 bits form the register data. [Figure 78](#) shows a diagram of the write timing.

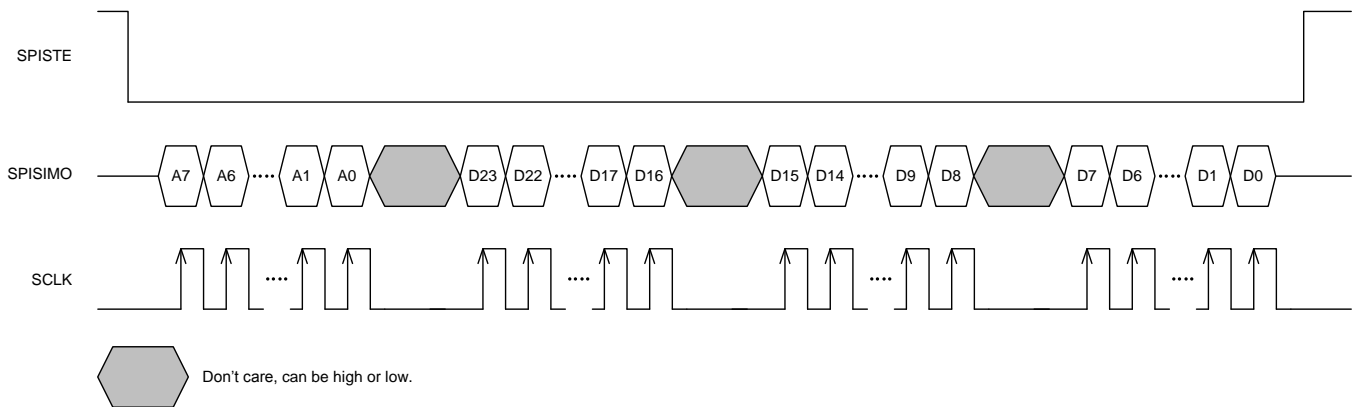
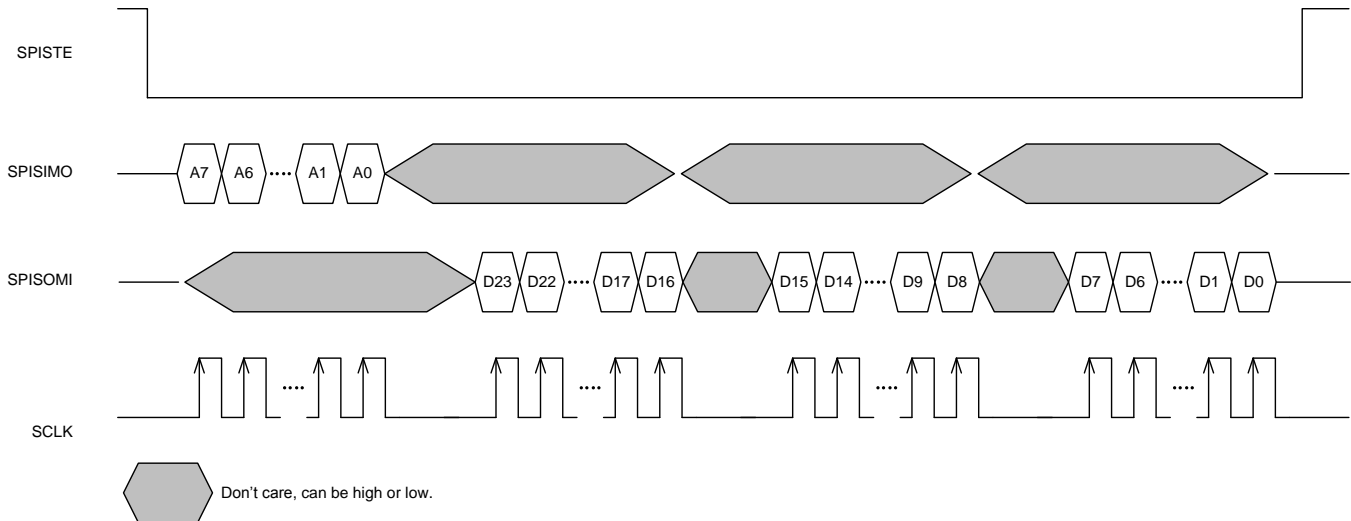

Figure 78. AFE SPI Write Timing Diagram

Reading Data

The AFE4490 includes a mode where the contents of the internal registers can be read back on the SPISOMI pin. This mode may be useful as a diagnostic check to verify the serial interface communication between the external controller and the AFE. To enable this mode, first set the SPI_READ register bit using the SPI write command, as described in the [Writing Data](#) section. In the next command, specify the SPI register address with the desired content to be read. Within the same SPI command sequence, the AFE outputs the contents of the specified register on the SPISOMI pin. [Figure 79](#) shows a timing diagram for the SPI read operation.



- (1) The SPI_READ register bit must be enabled before attempting a serial readout from the AFE.
- (2) Specify the register address of the content that must be readback on bits A[7:0].
- (3) The AFE outputs the contents of the specified register on the SPISOMI pin.

Figure 79. AFE SPI Read Timing Diagram⁽¹⁾⁽²⁾⁽³⁾

Register Initialization

After power-up, the internal registers must be initialized to the default values. This initialization can be done in one of two ways:

- Through a hardware reset by applying a low-going pulse on the $\overline{\text{RESET}}$ pin, or
- By applying a software reset. Using the serial interface, set SW_RESET (bit D3 in register 00h) high. This setting initializes the internal registers to the default values and then self-resets to '0'. In this case, the $\overline{\text{RESET}}$ pin is kept high (inactive).

AFE SPI Interface Design Considerations

Note that when the AFE4490 is deselected, the SPISOMI, CLKOUT, ADC_RDY, PD_ALM, LED_ALM, and DIAG_END digital output pins do not enter a 3-state mode. This condition, therefore, must be taken into account when connecting multiple devices to the SPI port and for power-management considerations.

AFE REGISTER MAP

The AFE consists of a set of registers that can be used to configure it, such as receiver timings, I-V amplifier settings, transmit LED currents, and so forth. The registers and their contents are listed in [Table 4](#). These registers can be accessed using the AFE SPI interface.

Table 4. AFE Register Map

NAME	ADDRESS		REGISTER DATA																							
	Hex	Dec	D23	D22	D21	D20	D19	D18	D17	D16	D15	D14	D13	D12	D11	D10	D9	D8	D7	D6	D5	D4	D3	D2	D1	D0
CONTROL0	00	0	0	0	0	0	0	0	0	0	0	0	0	0	0	0	0	0	0	0	0	0	SW_RST	DIAG_EN	TIM_COUNT_RST	SPI_READ
LED2STC	01	1	0	0	0	0	0	0	0	0	LED2STC[15:0]															
LED2ENDC	02	2	0	0	0	0	0	0	0	0	LED2ENDC[15:0]															
LED2LEDSTC	03	3	0	0	0	0	0	0	0	0	LED2LEDSTC[15:0]															
LED2LEDENDC	04	4	0	0	0	0	0	0	0	0	LED2LEDENDC[15:0]															
ALED2STC	05	5	0	0	0	0	0	0	0	0	ALED2STC[15:0]															
ALED2ENDC	06	6	0	0	0	0	0	0	0	0	ALED2ENDC[15:0]															
LED1STC	07	7	0	0	0	0	0	0	0	0	LED1STC[15:0]															
LED1ENDC	08	8	0	0	0	0	0	0	0	0	LED1ENDC[15:0]															
LED1LEDSTC	09	9	0	0	0	0	0	0	0	0	LED1LEDSTC[15:0]															
LED1LEDENDC	0A	10	0	0	0	0	0	0	0	0	LED1LEDENDC[15:0]															
ALED1STC	0B	11	0	0	0	0	0	0	0	0	ALED1STC[15:0]															
ALED1ENDC	0C	12	0	0	0	0	0	0	0	0	ALED1ENDC[15:0]															
LED2CONVST	0D	13	0	0	0	0	0	0	0	0	LED2CONVST[15:0]															
LED2CONVEND	0E	14	0	0	0	0	0	0	0	0	LED2CONVEND[15:0]															
ALED2CONVST	0F	15	0	0	0	0	0	0	0	0	ALED2CONVST[15:0]															
ALED2CONVEND	10	16	0	0	0	0	0	0	0	0	ALED2CONVEND[15:0]															
LED1CONVST	11	17	0	0	0	0	0	0	0	0	LED1CONVST[15:0]															
LED1CONVEND	12	18	0	0	0	0	0	0	0	0	LED1CONVEND[15:0]															
ALED1CONVST	13	19	0	0	0	0	0	0	0	0	ALED1CONVST[15:0]															
ALED1CONVEND	14	20	0	0	0	0	0	0	0	0	ALED1CONVEND[15:0]															
ADCRSTSTCT0	15	21	0	0	0	0	0	0	0	0	ADCRSTSTCT0[15:0]															
ADCRSTENDCT0	16	22	0	0	0	0	0	0	0	0	ADCRSTENDCT0[15:0]															
ADCRSTSTCT1	17	23	0	0	0	0	0	0	0	0	ADCRSTSTCT1[15:0]															
ADCRSTENDCT1	18	24	0	0	0	0	0	0	0	0	ADCRSTENDCT1[15:0]															
ADCRSTSTCT2	19	25	0	0	0	0	0	0	0	0	ADCRSTSTCT2[15:0]															
ADCRSTENDCT2	1A	26	0	0	0	0	0	0	0	0	ADCRSTENDCT2[15:0]															
ADCRSTSTCT3	1B	27	0	0	0	0	0	0	0	0	ADCRSTSTCT3[15:0]															
ADCRSTENDCT3	1C	28	0	0	0	0	0	0	0	0	ADCRSTENDCT3[15:0]															
PRPCOUNT	1D	29	0	0	0	0	0	0	0	0	PRPCT[15:0]															
CONTROL1	1E	30	0	0	0	0	0	0	0	0	0	0	0	0	CLKALMPIN[2:0]		TIMEREN	NUMAV[7:0]								
SPARE1	1F	31	0	0	0	0	0	0	0	0	0	0	0	0	0	0	0	0	0	0	0	0	0	0	0	0

Table 4. AFE Register Map (continued)

NAME	ADDRESS		REGISTER DATA																							
	Hex	Dec	D23	D22	D21	D20	D19	D18	D17	D16	D15	D14	D13	D12	D11	D10	D9	D8	D7	D6	D5	D4	D3	D2	D1	D0
TIAGAIN	20	32	0	0	0	0	0	0	0	0	ENSEPGAN	0	0	0	0	0	0	0	CF_LED1[4:0]				RF_LED1[2:0]			
TIA_AMB_GAIN	21	33	0	0	0	0	AMBDAC[3:0]				FLTRCNRSSEL	STAGEZEN	0	0	0	STG2GAIN[2:0]			CF_LED2[4:0]				RF_LED2[2:0]			
LEDCNTRL	22	34	0	0	0	0	0	0	LED RANGE[1:0]		LED1[7:0]							LED2[7:0]								
CONTROL2	23	35	0	0	0	0	0	TX_REF1	TX_REF0	0	EN_ADC_BYP	0	0	0	TXBRGMOD	0	XTALDIS	EN_SLOW_DIAG	0	0	0	0	0	PDNTX	PDNRX	PDNAFE
SPARE2	24	36	0	0	0	0	0	0	0	0	0	0	0	0	0	0	0	0	0	0	0	0	0	0	0	0
SPARE3	25	37	0	0	0	0	0	0	0	0	0	0	0	0	0	0	0	0	0	0	0	0	0	0	0	0
SPARE4	26	38	0	0	0	0	0	0	0	0	0	0	0	0	0	0	0	0	0	0	0	0	0	0	0	0
RESERVED1	27	39	X	X	X	X	X	X	X	X	X	X	X	X	X	X	X	X	X	X	X	X	X	X	X	X
RESERVED2	28	40	X	X	X	X	X	X	X	X	X	X	X	X	X	X	X	X	X	X	X	X	X	X	X	X
ALARM	29	41	0	0	0	0	0	0	0	0	0	0	0	0	0	0	0	0	ALMPINLKEN	0	0	0	0	0	0	0
LED2VAL	2A	42	LED2VAL[23:0]																							
ALED2VAL	2B	43	ALED2VAL[23:0]																							
LED1VAL	2C	44	LED1VAL[23:0]																							
ALED1VAL	2D	45	ALED1VAL[23:0]																							
LED2-ALED2VAL	2E	46	LED2-ALED2VAL[23:0]																							
LED1-ALED1VAL	2F	47	LED1-ALED1VAL[23:0]																							
DIAG	30	48	0	0	0	0	0	0	0	0	0	0	0	PD_ALM	LED_ALM	LED1OPEN	LED2OPEN	LEDSC	OUTPSHGND	OUTNSHGND	PDOC	PDSC	INNSCGND	INPSCGND	INNSCLED	INPSCLED

AFE REGISTER DESCRIPTION

CONTROL0: Control Register 0 (Address = 00h, Reset Value = 0000h)

D23	D22	D21	D20	D19	D18	D17	D16	D15	D14	D13	D12
0	0	0	0	0	0	0	0	0	0	0	0
D11	D10	D9	D8	D7	D6	D5	D4	D3	D2	D1	D0
0	0	0	0	0	0	0	0	SW_RST	DIAG_EN	TIM_COUNT_RST	SPI_READ

This register is used for AFE software and count timer reset, diagnostics enable, and SPI read functions.

Bits D[23:4] Must be '0'

Bit D3 SW_RST: Software reset

0 = No action (default after reset)

1 = Software reset applied; resets all internal registers to the default values and self-clears to '0'

Bit D2 DIAG_EN: Diagnostic enable

0 = No Action (default after reset)

1 = Diagnostic mode is enabled and the diagnostics sequence starts when this bit is set. At the end of the sequence, all fault statuses are stored in the [DIAG: Diagnostics Flag Register](#). Afterwards, the DIAG_EN register bit self-clears to '0'.

Bit D1 TIM_CNT_RST: Timer counter reset

0 = Disables timer counter reset, required for normal timer operation (default after reset)

1 = Timer counters are in reset state

Bit D0 SPI_READ: SPI read

0 = SPI read is disabled (default after reset)

1 = SPI read is enabled

LED2STC: Sample LED2 Start Count Register (Address = 01h, Reset Value = 0000h)

D23	D22	D21	D20	D19	D18	D17	D16	D15	D14	D13	D12
0	0	0	0	0	0	0	0	LED2STC[15:0]			
D11	D10	D9	D8	D7	D6	D5	D4	D3	D2	D1	D0
LED2STC[15:0]											

This register sets the start timing value for the LED2 signal sample.

Bits D[23:16] Must be '0'

Bits D[15:0] LED2STC[15:0]: Sample LED2 start count

The contents of this register can be used to position the start of the sample LED2 signal with respect to the pulse repetition period (PRP), as specified in the PRPCOUNT register. The count is specified as the number of 4-MHz clock cycles. Refer to the [Using the Timer Module](#) section for details.

LED2ENDC: Sample LED2 End Count Register (Address = 02h, Reset Value = 0000h)

D23	D22	D21	D20	D19	D18	D17	D16	D15	D14	D13	D12
0	0	0	0	0	0	0	0	LED2ENDC[15:0]			
D11	D10	D9	D8	D7	D6	D5	D4	D3	D2	D1	D0
LED2ENDC[15:0]											

This register sets the end timing value for the LED2 signal sample.

Bits D[23:16] Must be '0'

Bits D[15:0] LED2ENDC[15:0]: Sample LED2 end count

The contents of this register can be used to position the end of the sample LED2 signal with respect to the PRP, as specified in the PRPCOUNT register. The count is specified as the number of 4-MHz clock cycles. Refer to the [Using the Timer Module](#) section for details.

LED2LEDSTC: LED2 LED Start Count Register (Address = 03h, Reset Value = 0000h)

D23	D22	D21	D20	D19	D18	D17	D16	D15	D14	D13	D12
0	0	0	0	0	0	0	0	LED2LEDSTC[15:0]			
D11	D10	D9	D8	D7	D6	D5	D4	D3	D2	D1	D0
LED2LEDSTC[15:0]											

This register sets the start timing value for when the LED2 signal turns on.

Bits D[23:16] Must be '0'

Bits D[15:0] LED2LEDSTC[15:0]: LED2 start count

The contents of this register can be used to position the start of the LED2 with respect to the PRP, as specified in the PRPCOUNT register. The count is specified as the number of 4-MHz clock cycles. Refer to the [Using the Timer Module](#) section for details.

LED2LEDENDC: LED2 LED End Count Register (Address = 04h, Reset Value = 0000h)

D23	D22	D21	D20	D19	D18	D17	D16	D15	D14	D13	D12
0	0	0	0	0	0	0	0	LED2LEDENDC[15:0]			
D11	D10	D9	D8	D7	D6	D5	D4	D3	D2	D1	D0
LED2LEDENDC[15:0]											

This register sets the end timing value for when the LED2 signal turns off.

Bits D[23:16] Must be '0'

Bits D[15:0] LED2LEDENDC[15:0]: LED2 end count

The contents of this register can be used to position the end of the LED2 signal with respect to the PRP, as specified in the PRPCOUNT register. The count is specified as the number of 4-MHz clock cycles. Refer to the [Using the Timer Module](#) section for details.

ALED2STC: Sample Ambient LED2 Start Count Register (Address = 05h, Reset Value = 0000h)

D23	D22	D21	D20	D19	D18	D17	D16	D15	D14	D13	D12
0	0	0	0	0	0	0	0	ALED2STC[15:0]			
D11	D10	D9	D8	D7	D6	D5	D4	D3	D2	D1	D0
ALED2STC[15:0]											

This register sets the start timing value for the ambient LED2 signal sample.

Bits D[23:16] Must be '0'

Bits D[15:0] ALED2STC[15:0]: Sample ambient LED2 start count

The contents of this register can be used to position the start of the sample ambient LED2 signal with respect to the PRP, as specified in the PRPCOUNT register. The count is specified as the number of 4-MHz clock cycles. Refer to the [Using the Timer Module](#) section for details.

ALED2ENDC: Sample Ambient LED2 End Count Register (Address = 06h, Reset Value = 0000h)

D23	D22	D21	D20	D19	D18	D17	D16	D15	D14	D13	D12
0	0	0	0	0	0	0	0	ALED2ENDC[15:0]			
D11	D10	D9	D8	D7	D6	D5	D4	D3	D2	D1	D0
ALED2ENDC[15:0]											

This register sets the end timing value for the ambient LED2 signal sample.

Bits D[23:16] Must be '0'

Bits D[15:0] ALED2ENDC[15:0]: Sample ambient LED2 end count

The contents of this register can be used to position the end of the sample ambient LED2 signal with respect to the PRP, as specified in the PRPCOUNT register. The count is specified as the number of 4-MHz clock cycles. Refer to the [Using the Timer Module](#) section for details.

LED1STC: Sample LED1 Start Count Register (Address = 07h, Reset Value = 0000h)

D23	D22	D21	D20	D19	D18	D17	D16	D15	D14	D13	D12
0	0	0	0	0	0	0	0	LED1STC[15:0]			
D11	D10	D9	D8	D7	D6	D5	D4	D3	D2	D1	D0
LED1STC[15:0]											

This register sets the start timing value for the LED1 signal sample.

Bits D[23:17] Must be '0'

Bits D[16:0] LED1STC[15:0]: Sample LED1 start count

The contents of this register can be used to position the start of the sample LED1 signal with respect to the PRP, as specified in the PRPCOUNT register. The count is specified as the number of 4-MHz clock cycles. Refer to the [Using the Timer Module](#) section for details.

LED1ENDC: Sample LED1 End Count (Address = 08h, Reset Value = 0000h)

D23	D22	D21	D20	D19	D18	D17	D16	D15	D14	D13	D12
0	0	0	0	0	0	0	0	LED1ENDC[15:0]			
D11	D10	D9	D8	D7	D6	D5	D4	D3	D2	D1	D0
LED1ENDC[15:0]											

This register sets the end timing value for the LED1 signal sample.

Bits D[23:17] Must be '0'

Bits D[16:0] LED1ENDC[15:0]: Sample LED1 end count

The contents of this register can be used to position the end of the sample LED1 signal with respect to the PRP, as specified in the PRPCOUNT register. The count is specified as the number of 4-MHz clock cycles. Refer to the [Using the Timer Module](#) section for details.

LED1LEDSTC: LED1 LED Start Count Register (Address = 09h, Reset Value = 0000h)

D23	D22	D21	D20	D19	D18	D17	D16	D15	D14	D13	D12
0	0	0	0	0	0	0	0	LED1LEDSTC[15:0]			
D11	D10	D9	D8	D7	D6	D5	D4	D3	D2	D1	D0
LED1LEDSTC[15:0]											

This register sets the start timing value for when the LED1 signal turns on.

Bits D[23:16] Must be '0'

Bits D[15:0] LED1LEDSTC[15:0]: LED1 start count

The contents of this register can be used to position the start of the LED1 signal with respect to the PRP, as specified in the PRPCOUNT register. The count is specified as the number of 4-MHz clock cycles. Refer to the [Using the Timer Module](#) section for details.

LED1LEDENDC: LED1 LED End Count Register (Address = 0Ah, Reset Value = 0000h)

D23	D22	D21	D20	D19	D18	D17	D16	D15	D14	D13	D12
0	0	0	0	0	0	0	0	LED1LEDENDC[15:0]			
D11	D10	D9	D8	D7	D6	D5	D4	D3	D2	D1	D0
LED1LEDENDC[15:0]											

This register sets the end timing value for when the LED1 signal turns off.

Bits D[23:16] Must be '0'

Bits D[15:0] LED1LEDENDC[15:0]: LED1 end count

The contents of this register can be used to position the end of the LED1 signal with respect to the PRP, as specified in the PRPCOUNT register. The count is specified as the number of 4-MHz clock cycles. Refer to the [Using the Timer Module](#) section for details.

ALED1STC: Sample Ambient LED1 Start Count Register (Address = 0Bh, Reset Value = 0000h)

D23	D22	D21	D20	D19	D18	D17	D16	D15	D14	D13	D12
0	0	0	0	0	0	0	0	ALED1STC[15:0]			
D11	D10	D9	D8	D7	D6	D5	D4	D3	D2	D1	D0
ALED1STC[15:0]											

This register sets the start timing value for the ambient LED1 signal sample.

Bits D[23:16] Must be '0'

Bits D[15:0] ALED1STC[15:0]: Sample ambient LED1 start count

The contents of this register can be used to position the start of the sample ambient LED1 signal with respect to the PRP, as specified in the PRPCOUNT register. The count is specified as the number of 4-MHz clock cycles. Refer to the [Using the Timer Module](#) section for details.

ALED1ENDC: Sample Ambient LED1 End Count Register (Address = 0Ch, Reset Value = 0000h)

D23	D22	D21	D20	D19	D18	D17	D16	D15	D14	D13	D12
0	0	0	0	0	0	0	0	ALED1ENDC[15:0]			
D11	D10	D9	D8	D7	D6	D5	D4	D3	D2	D1	D0
ALED1ENDC[15:0]											

This register sets the end timing value for the ambient LED1 signal sample.

Bits D[23:16] Must be '0'

Bits D[15:0] ALED1ENDC[15:0]: Sample ambient LED1 end count

The contents of this register can be used to position the end of the sample ambient LED1 signal with respect to the PRP, as specified in the PRPCOUNT register. The count is specified as the number of 4-MHz clock cycles. Refer to the [Using the Timer Module](#) section for details.

LED2CONVST: LED2 Convert Start Count Register (Address = 0Dh, Reset Value = 0000h)

D23	D22	D21	D20	D19	D18	D17	D16	D15	D14	D13	D12
0	0	0	0	0	0	0	0	LED2CONVST[15:0]			
D11	D10	D9	D8	D7	D6	D5	D4	D3	D2	D1	D0
LED2CONVST[15:0]											

This register sets the start timing value for the LED2 conversion.

Bits D[23:16] Must be '0'

Bits D[15:0] LED2CONVST[15:0]: LED2 convert start count

The contents of this register can be used to position the start of the LED2 conversion signal with respect to the PRP, as specified in the PRPCOUNT register. The count is specified as the number of 4-MHz clock cycles. Refer to the [Using the Timer Module](#) section for details.

LED2CONVEND: LED2 Convert End Count Register (Address = 0Eh, Reset Value = 0000h)

D23	D22	D21	D20	D19	D18	D17	D16	D15	D14	D13	D12
0	0	0	0	0	0	0	0	LED2CONVEND[15:0]			
D11	D10	D9	D8	D7	D6	D5	D4	D3	D2	D1	D0
LED2CONVEND[15:0]											

This register sets the end timing value for the LED2 conversion.

Bits D[23:16] Must be '0'

Bits D[15:0] LED2CONVEND[15:0]: LED2 convert end count

The contents of this register can be used to position the end of the LED2 conversion signal with respect to the PRP, as specified in the PRPCOUNT register. The count is specified as the number of 4-MHz clock cycles. Refer to the [Using the Timer Module](#) section for details.

ALED2CONVST: LED2 Ambient Convert Start Count Register (Address = 0Fh, Reset Value = 0000h)

D23	D22	D21	D20	D19	D18	D17	D16	D15	D14	D13	D12
0	0	0	0	0	0	0	0	ALED2CONVST[15:0]			
D11	D10	D9	D8	D7	D6	D5	D4	D3	D2	D1	D0
ALED2CONVST[15:0]											

This register sets the start timing value for the ambient LED2 conversion.

Bits D[23:16] Must be '0'

Bits D[15:0] ALED2CONVST[15:0]: LED2 ambient convert start count

The contents of this register can be used to position the start of the LED2 ambient conversion signal with respect to the PRP, as specified in the PRPCOUNT register. The count is specified as the number of 4-MHz clock cycles. Refer to the [Using the Timer Module](#) section for details.

ALED2CONVEND: LED2 Ambient Convert End Count Register (Address = 10h, Reset Value = 0000h)

D23	D22	D21	D20	D19	D18	D17	D16	D15	D14	D13	D12
0	0	0	0	0	0	0	0	ALED2CONVEND[15:0]			
D11	D10	D9	D8	D7	D6	D5	D4	D3	D2	D1	D0
ALED2CONVEND[15:0]											

This register sets the end timing value for the ambient LED2 conversion.

Bits D[23:16] Must be '0'

Bits D[15:0] ALED2CONVEND[15:0]: LED2 ambient convert end count

The contents of this register can be used to position the end of the LED2 ambient conversion signal with respect to the PRP. The count is specified as the number of 4-MHz clock cycles. Refer to the [Using the Timer Module](#) section for details.

LED1CONVST: LED1 Convert Start Count Register (Address = 11h, Reset Value = 0000h)

D23	D22	D21	D20	D19	D18	D17	D16	D15	D14	D13	D12
0	0	0	0	0	0	0	0	LED1CONVST[15:0]			
D11	D10	D9	D8	D7	D6	D5	D4	D3	D2	D1	D0
LED1CONVST[15:0]											

This register sets the start timing value for the LED1 conversion.

Bits D[23:16] Must be '0'

Bits D[15:0] LED1CONVST[15:0]: LED1 convert start count

The contents of this register can be used to position the start of the LED1 conversion signal with respect to the PRP, as specified in the PRPCOUNT register. The count is specified as the number of 4-MHz clock cycles. Refer to the [Using the Timer Module](#) section for details.

LED1CONVEND: LED1 Convert End Count Register (Address = 12h, Reset Value = 0000h)

D23	D22	D21	D20	D19	D18	D17	D16	D15	D14	D13	D12
0	0	0	0	0	0	0	0	LED1CONVEND[15:0]			
D11	D10	D9	D8	D7	D6	D5	D4	D3	D2	D1	D0
LED1CONVEND[15:0]											

This register sets the end timing value for the LED1 conversion.

Bits D[23:16] Must be '0'

Bits D[15:0] LED1CONVEND[15:0]: LED1 convert end count

The contents of this register can be used to position the end of the LED1 conversion signal with respect to the PRP. The count is specified as the number of 4-MHz clock cycles. Refer to the [Using the Timer Module](#) section for details.

ALED1CONVST: LED1 Ambient Convert Start Count Register (Address = 13h, Reset Value = 0000h)

D23	D22	D21	D20	D19	D18	D17	D16	D15	D14	D13	D12
0	0	0	0	0	0	0	0	ALED1CONVST[15:0]			
D11	D10	D9	D8	D7	D6	D5	D4	D3	D2	D1	D0
ALED1CONVST[15:0]											

This register sets the start timing value for the ambient LED1 conversion.

Bits D[23:16] Must be '0'

Bits D[15:0] ALED1CONVST[15:0]: LED1 ambient convert start count

The contents of this register can be used to position the start of the LED1 ambient conversion signal with respect to the PRP, as specified in the PRPCOUNT register. The count is specified as the number of 4-MHz clock cycles. Refer to the [Using the Timer Module](#) section for details.

ALED1CONVEND: LED1 Ambient Convert End Count Register (Address = 14h, Reset Value = 0000h)

D23	D22	D21	D20	D19	D18	D17	D16	D15	D14	D13	D12
0	0	0	0	0	0	0	0	ALED1CONVEND[15:0]			
D11	D10	D9	D8	D7	D6	D5	D4	D3	D2	D1	D0
ALED1CONVEND[15:0]											

This register sets the end timing value for the ambient LED1 conversion.

Bits D[23:16] Must be '0'

Bits D[15:0] ALED1CONVEND[15:0]: LED1 ambient convert end count

The contents of this register can be used to position the end of the LED1 ambient conversion signal with respect to the PRP. The count is specified as the number of 4-MHz clock cycles. Refer to the [Using the Timer Module](#) section for details.

ADCRSTSTCT0: ADC Reset 0 Start Count Register (Address = 15h, Reset Value = 0000h)

D23	D22	D21	D20	D19	D18	D17	D16	D15	D14	D13	D12
0	0	0	0	0	0	0	0	ADCRSTSTCT0[15:0]			
D11	D10	D9	D8	D7	D6	D5	D4	D3	D2	D1	D0
ADCRSTSTCT0[15:0]											

This register sets the start position of the ADC0 reset conversion signal.

Bits D[23:16] Must be '0'

Bits D[15:0] ADCRSTSTCT0[15:0]: ADC RESET 0 start count

The contents of this register can be used to position the start of the ADC reset conversion signal (default value after reset is 0000h). Refer to the [Using the Timer Module](#) section for details.

ADCRSTENDCT0: ADC Reset 0 End Count Register (Address = 16h, Reset Value = 0000h)

D23	D22	D21	D20	D19	D18	D17	D16	D15	D14	D13	D12
0	0	0	0	0	0	0	0	ADCRSTENDCT0[15:0]			
D11	D10	D9	D8	D7	D6	D5	D4	D3	D2	D1	D0
ADCRSTENDCT0[15:0]											

This register sets the end position of the ADC0 reset conversion signal.

Bits D[23:16] Must be '0'

Bits D[15:0] ADCRSTENDCT0[15:0]: ADC RESET 0 end count

The contents of this register can be used to position the end of the ADC reset conversion signal (default value after reset is 0000h). Refer to the [Using the Timer Module](#) section for details.

ADCRSTSTCT1: ADC Reset 1 Start Count Register (Address = 17h, Reset Value = 0000h)

D23	D22	D21	D20	D19	D18	D17	D16	D15	D14	D13	D12
0	0	0	0	0	0	0	0	ADCRSTSTCT1[15:0]			
D11	D10	D9	D8	D7	D6	D5	D4	D3	D2	D1	D0
ADCRSTSTCT1[15:0]											

This register sets the start position of the ADC1 reset conversion signal.

Bits D[23:16] Must be '0'

Bits D[15:0] ADCRSTSTCT1[15:0]: ADC RESET 1 start count

The contents of this register can be used to position the start of the ADC reset conversion. Refer to the [Using the Timer Module](#) section for details.

ADCRSTENDCT1: ADC Reset 1 End Count Register (Address = 18h, Reset Value = 0000h)

D23	D22	D21	D20	D19	D18	D17	D16	D15	D14	D13	D12
0	0	0	0	0	0	0	0	ADCRSTENDCT1[15:0]			
D11	D10	D9	D8	D7	D6	D5	D4	D3	D2	D1	D0
ADCRSTENDCT1[15:0]											

This register sets the end position of the ADC1 reset conversion signal.

Bits D[23:16] Must be '0'

Bits D[15:0] ADCRSTENDCT1[15:0]: ADC RESET 1 end count

The contents of this register can be used to position the end of the ADC reset conversion. Refer to the [Using the Timer Module](#) section for details.

ADCRSTSTCT2: ADC Reset 2 Start Count Register (Address = 19h, Reset Value = 0000h)

D23	D22	D21	D20	D19	D18	D17	D16	D15	D14	D13	D12
0	0	0	0	0	0	0	0	ADCRSTSTCT2[15:0]			
D11	D10	D9	D8	D7	D6	D5	D4	D3	D2	D1	D0
ADCRSTSTCT2[15:0]											

This register sets the start position of the ADC2 reset conversion signal.

Bits D[23:16] Must be '0'

Bits D[15:0] ADCRSTSTCT2[15:0]: ADC RESET 2 start count

The contents of this register can be used to position the start of the ADC reset conversion. Refer to the [Using the Timer Module](#) section for details.

ADCRSTENDCT2: ADC Reset 2 End Count Register (Address = 1Ah, Reset Value = 0000h)

D23	D22	D21	D20	D19	D18	D17	D16	D15	D14	D13	D12
0	0	0	0	0	0	0	0	ADCRSTENDCT2[15:0]			
D11	D10	D9	D8	D7	D6	D5	D4	D3	D2	D1	D0
ADCRSTENDCT2[15:0]											

This register sets the end position of the ADC2 reset conversion signal.

Bits D[23:16] Must be '0'

Bits D[15:0] ADCRSTENDCT2[15:0]: ADC RESET 2 end count

The contents of this register can be used to position the end of the ADC reset conversion. Refer to the [Using the Timer Module](#) section for details.

ADCRSTSTCT3: ADC Reset 3 Start Count Register (Address = 1Bh, Reset Value = 0000h)

D23	D22	D21	D20	D19	D18	D17	D16	D15	D14	D13	D12
0	0	0	0	0	0	0	0	ADCRSTSTCT3[15:0]			
D11	D10	D9	D8	D7	D6	D5	D4	D3	D2	D1	D0
ADCRSTSTCT3[15:0]											

This register sets the start position of the ADC3 reset conversion signal.

Bits D[23:16] Must be '0'

Bits D[15:0] ADCRSTSTCT3[15:0]: ADC RESET 3 start count

The contents of this register can be used to position the start of the ADC reset conversion. Refer to the [Using the Timer Module](#) section for details.

ADCRSTENDCT3: ADC Reset 3 End Count Register (Address = 1Ch, Reset Value = 0000h)

D23	D22	D21	D20	D19	D18	D17	D16	D15	D14	D13	D12
0	0	0	0	0	0	0	0	ADCRSTENDCT3[15:0]			
D11	D10	D9	D8	D7	D6	D5	D4	D3	D2	D1	D0
ADCRSTENDCT3[15:0]											

This register sets the end position of the ADC3 reset conversion signal.

Bits D[23:16] Must be '0'

Bits D[15:0] ADCRSTENDCT3[15:0]: ADC RESET 3 end count

The contents of this register can be used to position the end of the ADC reset conversion signal (default value after reset is 0000h). Refer to the [Using the Timer Module](#) section for details.

PRPCOUNT: Pulse Repetition Period Count Register (Address = 1Dh, Reset Value = 0000h)

D23	D22	D21	D20	D19	D18	D17	D16	D15	D14	D13	D12
0	0	0	0	0	0	0	0	PRPCOUNT[15:0]			
D11	D10	D9	D8	D7	D6	D5	D4	D3	D2	D1	D0
PRPCOUNT[15:0]											

This register sets the device pulse repetition period count.

Bits D[23:16] Must be '0'

Bits D[15:0] PRPCOUNT[15:0]: Pulse repetition period count

The contents of this register can be used to set the pulse repetition period (in number of clock cycles of the 4-MHz clock).

CONTROL1: Control Register 1 (Address = 1Eh, Reset Value = 0000h)

D23	D22	D21	D20	D19	D18	D17	D16	D15	D14	D13	D12
0	0	0	0	0	0	0	0	0	0	0	0
D11	D10	D9	D8	D7	D6	D5	D4	D3	D2	D1	D0
CLKALMPIN[2:0]			TIMEREN	NUMAV[7:0]							

This register configures the clock alarm pin, timer, and number of averages.

Bits D[23:12] Must be '0'

Bits D[11:9] CLKALMPIN[2:0]: Clocks on ALM pins

Internal clocks can be brought to the PD_ALM and LED_ALM pins for monitoring. Note that the CLKALMPIN[2:0] register bits must be set before using this register bit. [Table 5](#) defines the settings for the two alarm pins.

Bit D8 TIMEREN: Timer enable

0 = Timer module is disabled and all internal clocks are off (default after reset)
1 = Timer module is enabled

Bits D[7:0] NUMAV[7:0]: Number of averages

Specify an 8-bit value corresponding to the number of ADC samples to be averaged – 1. For example, to average four ADC samples, set NUMAV[7:0] equal to 3.

Table 5. PD_ALM and LED_ALM Pin Settings

CLKALMPIN[2:0]	PD_ALM PIN SIGNAL	LED_ALM PIN SIGNAL
000	Sample LED2	Sample LED1
001	LED2 pulse	LED1 pulse
010	Sample LED2	Sample LED1 pulse
011	LED2 convert	LED1 convert
100	LED2 ambient	LED1 ambient
101	No output	No output
110	No output	No output
111	No output	No output

SPARE1: SPARE1 Register For Future Use (Address = 1Fh, Reset Value = 0000h)

D23	D22	D21	D20	D19	D18	D17	D16	D15	D14	D13	D12
0	0	0	0	0	0	0	0	0	0	0	0
D11	D10	D9	D8	D7	D6	D5	D4	D3	D2	D1	D0
0	0	0	0	0	0	0	0	0	0	0	0

This register is a spare register and is reserved for future use.

Bits D[23:0] Must be '0'

TIAGAIN: Transimpedance Amplifier Gain Setting Register (Address = 20h, Reset Value = 0000h)

D23	D22	D21	D20	D19	D18	D17	D16	D15	D14	D13	D12
0	0	0	0	0	0	0	0	ENSEP GAIN	0	0	0
D11	D10	D9	D8	D7	D6	D5	D4	D3	D2	D1	D0
0	0	0	0	CF_LED1[4:0]				RF_LED1[2:0]			

This register sets the device transimpedance amplifier gain mode and feedback resistor and capacitor values.

Bits D[23:16] Must be '0'

Bit D15 ENSEPGAIN: Enable separate gain mode

0 = The R_F and C_F values are the same for both LED2 and LED1 signals; the value specified by the RF_LED2[2:0] register bits is used (default after reset)

1 = The R_F value is different for the LED2 and LED1 signals; the values are specified by the RF_LED1[2:0] and RF_LED2[2:0] register bits

Bits D[14:8] Must be '0'

Bits D[7:3] CF_LED1[4:0]: Program C_F for LED1

00000 = 5 pF (default after reset)

00001 = 5 pF + 5 pF

00010 = 15 pF + 5 pF

00100 = 25 pF + 5 pF

01000 = 50 pF + 5 pF

10000 = 150 pF + 5 pF

Note that any combination of these C_F settings is also supported by setting multiple bits to '1'. For example, to obtain $C_F = 100$ pF, set D[7:3] = 01111.

Bits D[2:0] RF_LED1[2:0]: Program R_F for LED1

000 = 500 k Ω (default after reset)

001 = 250 k Ω

010 = 100 k Ω

011 = 50 k Ω

100 = 25 k Ω

101 = 10 k Ω

110 = 1 M Ω

111 = None

TIA_AMB_GAIN: Transimpedance Amplifier and Ambient Cancellation Stage Gain Register
(Address = 21h, Reset Value = 0000h)

D23	D22	D21	D20	D19	D18	D17	D16	D15	D14	D13	D12
0	0	0	0	AMBDAC[3:0]				FLTR CNRSEL	STAGE2 EN	0	0
D11	D10	D9	D8	D7	D6	D5	D4	D3	D2	D1	D0
0	STG2GAIN[2:0]			CF_LED2[4:0]				RF_LED2[2:0]			

This register configures the ambient light cancellation amplifier gain, cancellation current, and filter corner frequency.

Bits D[23:20] Must be '0'

Bits D[19:16] AMBDAC[3:0]: Ambient DAC value

These bits set the value of the cancellation current.

0000 = 0 μ A (default after reset)	1000 = 8 μ A
0001 = 1 μ A	1001 = 9 μ A
0010 = 2 μ A	1010 = 10 μ A
0011 = 3 μ A	1011 = Do not use
0100 = 4 μ A	1100 = Do not use
0101 = 5 μ A	1101 = Do not use
0110 = 6 μ A	1110 = Do not use
0111 = 7 μ A	1111 = Do not use

Bit D15 FLTRCNRSEL: Filter corner selection

0 = 500-Hz filter corner (default after reset)
1 = 1000-Hz filter corner

Bit D14 STAGE2EN: Stage 2 enable

0 = Stage 2 is bypassed (default after reset)
1 = Stage 2 is enabled with the gain value specified by the STG2GAIN[2:0] bits

Bits D[13:11] Must be '0'

Bits D[10:8] STG2GAIN[2:0]: Stage 2 gain setting

000 = 0 dB, or linear gain of 1 (default after reset)	100 = 12 dB, or linear gain of 4
001 = 3 dB, or linear gain of 1.414	101 = Do not use
010 = 6 dB, or linear gain of 2	110 = Do not use
011 = 9 dB, or linear gain of 2.818	111 = Do not use

Bits D[7:3] CF_LED2[4:0]: Program C_F for LED2

00000 = 5 pF (default after reset)	00100 = 25 pF + 5 pF
00001 = 5 pF + 5 pF	01000 = 50 pF + 5 pF
00010 = 15 pF + 5 pF	10000 = 150 pF + 5 pF

Note that any combination of these C_F settings is also supported by setting multiple bits to '1'. For example, to obtain $C_F = 100$ pF, set D[7:3] = 01111.

Bits D[2:0] RF_LED2[2:0]: Program R_F for LED2

000 = 500 k Ω	100 = 25 k Ω
001 = 250 k Ω	101 = 10 k Ω
010 = 100 k Ω	110 = 1 M Ω
011 = 50 k Ω	111 = None

LEDCNTRL: LED Control Register (Address = 22h, Reset Value = 0000h)

D23	D22	D21	D20	D19	D18	D17	D16	D15	D14	D13	D12
0	0	0	0	0	0	LED_RANGE[1:0]		LED1[7:0]			
D11	D10	D9	D8	D7	D6	D5	D4	D3	D2	D1	D0
LED1[7:0]					LED2[7:0]						

This register sets the LED current range and the LED1 and LED2 drive current.

Bits D[23:18] Must be '0'

Bits D[17:16] LED_RANGE[1:0]: LED range

These bits program the full-scale LED current range for Tx. [Table 6](#) details the settings.

Bits D[15:8] LED1[7:0]: Program LED current for LED1 signal

Use these register bits to specify the LED current setting for LED1 (default after reset is 00h).

The nominal value of the LED current is given by [Equation 4](#), where the full-scale LED current is either 0 mA, 50 mA, 75 mA, 100 mA, 150 mA, or 200 mA (as specified by the LED_RANGE[1:0] register bits).

Bits D[7:0] LED2[7:0]: Program LED current for LED2 signal

Use these register bits to specify the LED current setting for LED2 (default after reset is 00h).

The nominal value of LED current is given by [Equation 5](#), where the full-scale LED current is either 0 mA, 50 mA, 75 mA, 100 mA, 150 mA, or 200 mA (as specified by the LED_RANGE[1:0] register bits).

Table 6. Full-Scale LED Current across Tx Reference Voltage Settings⁽¹⁾

LED_RANGE[1:0]	LED CURRENT RANGE FOR Tx REFERENCE VOLTAGE		
	0.75 V (TX_REF[1:0] = 00)	0.5 V (TX_REF[1:0] = 01)	1.0 V (TX_REF[1:0] = 10)
00 (default after reset)	150 mA	100 mA	200 mA
01	75 mA	50 mA	100 mA
10	150 mA	100 mA	200 mA
11	Tx is off	Tx is off	Tx is off

(1) For a 3-V to 3.6-V supply, use TX_REF = 0.5 V. For a 4.75-V to 5.25-V supply, use TX_REF = 0.75 V or 1.0 V.

$$\frac{\text{LED1}[7:0]}{256} \times \text{Full-Scale Current} \quad (4)$$

$$\frac{\text{LED2}[7:0]}{256} \times \text{Full-Scale Current} \quad (5)$$

CONTROL2: Control Register 2 (Address = 23h, Reset Value = 0000h)

D23	D22	D21	D20	D19	D18	D17	D16	D15	D14	D13	D12
0	0	0	0	0	TX_REF1	TX_REF0	0	EN_ADC_BYP	0	0	0
D11	D10	D9	D8	D7	D6	D5	D4	D3	D2	D1	D0
TXBRG_MOD	0	XTAL_DIS	EN_SLOW_DIAG	0	0	0	0	0	PDNTX	PDNRX	PDNAFE

This register controls the LED transmitter, crystal, and the AFE, transmitter, and receiver power modes.

Bits D[23:19] Must be '0'

Bits D[18:17] TX_REF[1:0]: Tx reference voltage

These bits set the transmitter reference voltage. This Tx reference voltage is available on the device TX_REF pin.

00 = 0.75-V Tx reference voltage (default value after reset)

01 = 0.5-V Tx reference voltage

10 = 1.0-V Tx reference voltage

11 = 0.75-V Tx reference voltage

NOTE: For best results, use TX_REF = 0.5 V for 3-V operation. Use TX_REF = 0.75V and TX_REF = 1.0 V for 5-V operation.

Bit D16 Must be '0'

Bit D15 EN_ADC_BYP: ADC bypass mode enable

0 = Normal mode, the internal ADC is active (default after reset)

1 = ADC bypass mode, the analog signal is output to the ADC_BYPP and ADC_BYPN pins

Bits D[14:12] Must be '0'

Bit D11 TXBRG_MOD: Tx bridge mode

0 = LED driver is configured as an H-bridge (default after reset)

1 = LED driver is configured as a push-pull

Bit D10 Must be '0'

Bit D9 XTALDIS: Crystal disable mode

0 = The crystal module is enabled; the 8-MHz crystal must be connected to the XIN and XOUT pins

1 = The crystal module is disabled; an external 8-MHz clock must be applied to the XIN pin

Bit D8 EN_SLOW_DIAG: Fast diagnostics mode enable

0 = Fast diagnostics mode, 8 ms (default value after reset)

1 = Slow diagnostics mode, 16 ms

Bits D[7:3] Must be '0'

Bit D2 PDN_TX: Tx power-down

0 = The Tx is powered up (default after reset)

1 = Only the Tx module is powered down

Bit D1 PDN_RX: Rx power-down

0 = The Rx is powered up (default after reset)

1 = Only the Rx module is powered down

Bit D0 PDN_AFE: AFE power-down

0 = The AFE is powered up (default after reset)

1 = The entire AFE is powered down (including the Tx, Rx, and diagnostics blocks)

SPARE2: SPARE2 Register For Future Use (Address = 24h, Reset Value = 0000h)

D23	D22	D21	D20	D19	D18	D17	D16	D15	D14	D13	D12
0	0	0	0	0	0	0	0	0	0	0	0
D11	D10	D9	D8	D7	D6	D5	D4	D3	D2	D1	D0
0	0	0	0	0	0	0	0	0	0	0	0

This register is a spare register and is reserved for future use.

Bits D[23:0] Must be '0'

SPARE3: SPARE3 Register For Future Use (Address = 25h, Reset Value = 0000h)

D23	D22	D21	D20	D19	D18	D17	D16	D15	D14	D13	D12
0	0	0	0	0	0	0	0	0	0	0	0
D11	D10	D9	D8	D7	D6	D5	D4	D3	D2	D1	D0
0	0	0	0	0	0	0	0	0	0	0	0

This register is a spare register and is reserved for future use.

Bits D[23:0] Must be '0'

SPARE4: SPARE4 Register For Future Use (Address = 26h, Reset Value = 0000h)

D23	D22	D21	D20	D19	D18	D17	D16	D15	D14	D13	D12
0	0	0	0	0	0	0	0	0	0	0	0
D11	D10	D9	D8	D7	D6	D5	D4	D3	D2	D1	D0
0	0	0	0	0	0	0	0	0	0	0	0

This register is a spare register and is reserved for future use.

Bits D[23:0] Must be '0'

RESERVED1: RESERVED1 Register For Factory Use Only (Address = 27h, Reset Value = XXXXh)

D23	D22	D21	D20	D19	D18	D17	D16	D15	D14	D13	D12
X	X	X	X	X	X	X	X	X	X	X	X
D11	D10	D9	D8	D7	D6	D5	D4	D3	D2	D1	D0
X	X	X	X	X	X	X	X	X	X	X	X

A. X = don't care.

This register is reserved for factory use. Readback values vary between devices.

Bits D[23:0] Must be '0'**RESERVED2: RESERVED2 Register For Factory Use Only (Address = 28h, Reset Value = XXXXh)**

D23	D22	D21	D20	D19	D18	D17	D16	D15	D14	D13	D12
X	X	X	X	X	X	X	X	X	X	X	X
D11	D10	D9	D8	D7	D6	D5	D4	D3	D2	D1	D0
X	X	X	X	X	X	X	X	X	X	X	X

B. X = don't care.

This register is reserved for factory use. Readback values vary between devices.

Bits D[23:0] Must be '0'**ALARM: Alarm Register (Address = 29h, Reset Value = 0000h)**

D23	D22	D21	D20	D19	D18	D17	D16	D15	D14	D13	D12
0	0	0	0	0	0	0	0	0	0	0	0
D11	D10	D9	D8	D7	D6	D5	D4	D3	D2	D1	D0
0	0	0	0	ALMPIN CLKEN	0	0	0	0	0	0	0

This register controls the Alarm pin functionality.

Bits D[23:8] Must be '0'**Bit D7 ALMPINCLKEN: Alarm pin clock enable**

0 = Disables the monitoring of internal clocks; the PD_ALM and LED_ALM pins function as diagnostic fault alarm output pins (default after reset)

1 = Enables the monitoring of internal clocks; these clocks can be brought out on PD_ALM and LED_ALM selectively (depending on the value of the CLKALMPIN[2:0] register bits).

Bits D[6:0] Must be '0'

LED2VAL: LED2 Digital Sample Value Register (Address = 2Ah, Reset Value = 0000h)

D23	D22	D21	D20	D19	D18	D17	D16	D15	D14	D13	D12
LED2VAL[23:0]											
D11	D10	D9	D8	D7	D6	D5	D4	D3	D2	D1	D0
LED2VAL[23:0]											

This register contains the digital value of the latest LED2 sample converted by the ADC. The ADC_RDY signal goes high each time that the contents of this register are updated. The host processor must readout this register before the next sample is converted by the AFE.

Bits D[23:0] LED2VAL[23:0]: LED2 digital value

This register contains the digital value of the latest LED2 sample converted by the ADC. The ADC_RDY signal goes high each time that the contents of this register are updated. The host processor must readout this register before the next sample is converted by the AFE.

ALED2VAL: Ambient LED2 Digital Sample Value Register (Address = 2Bh, Reset Value = 0000h)

D23	D22	D21	D20	D19	D18	D17	D16	D15	D14	D13	D12
ALED2VAL[23:0]											
D11	D10	D9	D8	D7	D6	D5	D4	D3	D2	D1	D0
ALED2VAL[23:0]											

This register contains the digital value of the latest LED2 ambient sample converted by the ADC. The ADC_RDY signal goes high each time that the contents of this register are updated. The host processor must readout this register before the next sample is converted by the AFE.

Bits D[23:0] ALED2VAL[23:0]: LED2 ambient digital value

This register contains the digital value of the latest LED2 ambient sample converted by the ADC. The ADC_RDY signal goes high each time that the contents of this register are updated. The host processor must readout this register before the next sample is converted by the AFE.

LED1VAL: LED1 Digital Sample Value Register (Address = 2Ch, Reset Value = 0000h)

D23	D22	D21	D20	D19	D18	D17	D16	D15	D14	D13	D12
LED1VAL[23:0]											
D11	D10	D9	D8	D7	D6	D5	D4	D3	D2	D1	D0
LED1VAL[23:0]											

This register contains the digital value of the latest LED1 sample converted by the ADC. The ADC_RDY signal goes high each time that the contents of this register are updated. The host processor must readout this register before the next sample is converted by the AFE.

Bits D[23:0] LED1VAL[23:0]: LED1 digital value

This register contains the digital value of the latest LED1 sample converted by the ADC. The ADC_RDY signal goes high each time that the contents of this register are updated. The host processor must readout this register before the next sample is converted by the AFE.

ALED1VAL: Ambient LED1 Digital Sample Value Register (Address = 2Dh, Reset Value = 0000h)

D23	D22	D21	D20	D19	D18	D17	D16	D15	D14	D13	D12
ALED1VAL[23:0]											
D11	D10	D9	D8	D7	D6	D5	D4	D3	D2	D1	D0
ALED1VAL[23:0]											

This register contains the digital value of the latest LED1 ambient sample converted by the ADC. The ADC_RDY signal goes high each time that the contents of this register are updated. The host processor must readout this register before the next sample is converted by the AFE.

Bits D[23:0] ALED1VAL[23:0]: LED1 ambient digital value

This register contains the digital value of the latest LED1 ambient sample converted by the ADC. The ADC_RDY signal goes high each time that the contents of this register are updated. The host processor must readout this register before the next sample is converted by the AFE.

**LED2-ALED2VAL: LED2-Ambient LED2 Digital Sample Value Register
(Address = 2Eh, Reset Value = 0000h)**

D23	D22	D21	D20	D19	D18	D17	D16	D15	D14	D13	D12
LED2-ALED2VAL[23:0]											
D11	D10	D9	D8	D7	D6	D5	D4	D3	D2	D1	D0
LED2-ALED2VAL[23:0]											

This register contains the digital value of the LED2 sample after the LED2 ambient is subtracted. The host processor must readout this register before the next sample is converted by the AFE.

Bits D[23:0] LED2-ALED2VAL[23:0]: (LED2 – LED2 ambient) digital value

This register contains the digital value of the LED2 sample after the LED2 ambient is subtracted. The host processor must readout this register before the next sample is converted by the AFE.

Note that this value is inverted when compared to waveforms shown in many publications.

**LED1-ALED1VAL: LED1-Ambient LED1 Digital Sample Value Register
(Address = 2Fh, Reset Value = 0000h)**

D23	D22	D21	D20	D19	D18	D17	D16	D15	D14	D13	D12
LED1-ALED1VAL[23:0]											
D11	D10	D9	D8	D7	D6	D5	D4	D3	D2	D1	D0
LED1-ALED1VAL[23:0]											

This register contains the digital value of the LED1 sample after the LED1 ambient is subtracted. The host processor must readout this register before the next sample is converted by the AFE.

Bits D[23:0] LED1-ALED1VAL[23:0]: (LED1 – LED1 ambient) digital value

This register contains the digital value of the LED1 sample after the LED1 ambient is subtracted from it. The host processor must readout this register before the next sample is converted by the AFE.

Note that this value is inverted when compared to waveforms shown in many publications.

DIAG: Diagnostics Flag Register (Address = 30h, Reset Value = 0000h)

D23	D22	D21	D20	D19	D18	D17	D16	D15	D14	D13	D12
0	0	0	0	0	0	0	0	0	0	0	PD_ALM
D11	D10	D9	D8	D7	D6	D5	D4	D3	D2	D1	D0
LED_ALM	LED1_OPEN	LED2_OPEN	LEDSC	OUTPSH_GND	OUTNSH_GND	PDOC	PDSC	INNSC_GND	INPSC_GND	INNSC_LED	INPSC_LED

This register is read only. This register contains the status of all diagnostic flags at the end of the diagnostics sequence. The end of the diagnostics sequence is indicated by the signal going high on DIAG_END pin.

Bits D[23:13] Read only

Bit D12 PD_ALM: Power-down alarm status diagnostic flag

This bit indicates the status of PD_ALM (and the PD_ALM pin).
 0 = No fault (default after reset)
 1 = Fault present

Bit D11 LED_ALM: LED alarm status diagnostic flag

This bit indicates the status of LED_ALM (and the LED_ALM pin).
 0 = No fault (default after reset)
 1 = Fault present

Bit D10 LED1OPEN: LED1 open diagnostic flag

This bit indicates that LED1 is open.
 0 = No fault (default after reset)
 1 = Fault present

Bit D9 LED2OPEN: LED2 open diagnostic flag

This bit indicates that LED2 is open.
 0 = No fault (default after reset)
 1 = Fault present

Bit D8 LEDSC: LED short diagnostic flag

This bit indicates an LED short.
 0 = No fault (default after reset)
 1 = Fault present

Bit D7 OUTPSHGND: OUTP to GND diagnostic flag

This bit indicates that OUTP is shorted to the GND cable.
 0 = No fault (default after reset)
 1 = Fault present

Bit D6 OUTNSHGND: OUTN to GND diagnostic flag

This bit indicates that OUTN is shorted to the GND cable.
 0 = No fault (default after reset)
 1 = Fault present

Bit D5 PDOC: PD open diagnostic flag

This bit indicates that PD is open.
 0 = No fault (default after reset)
 1 = Fault present

Bit D4 PDSC: PD short diagnostic flag

This bit indicates a PD short.
 0 = No fault (default after reset)
 1 = Fault present

- Bit D3** **INNSCGND: INN to GND diagnostic flag**
This bit indicates a short from the INN pin to the GND cable.
0 = No fault (default after reset)
1 = Fault present
- Bit D2** **INPSCGND: INP to GND diagnostic flag**
This bit indicates a short from the INP pin to the GND cable.
0 = No fault (default after reset)
1 = Fault present
- Bit D1** **INNSCLED: INN to LED diagnostic flag**
This bit indicates a short from the INN pin to the LED cable.
0 = No fault (default after reset)
1 = Fault present
- Bit D0** **INPSCLED: INP to LED diagnostic flag**
This bit indicates a short from the INP pin to the LED cable.
0 = No fault (default after reset)
1 = Fault present

REVISION HISTORY

NOTE: Page numbers for previous revisions may differ from page numbers in the current version.

Changes from Revision C (April 2013) to Revision D	Page
• Added <i>CMRR</i> parameter to Electrical Characteristics table	4
• Added External Clock, <i>External clock input voltage</i> and <i>External clock input current</i> parameters to Electrical Characteristics table	6
• Changed TIMING, t_{RESET} parameter unit in Electrical Characteristics table	6
• Added <i>Pin Leakage Current</i> section to Electrical Characteristics table	6
• Added Supply Current, <i>ADC bypass mode</i> parameter to Electrical Characteristics table	7
• Changed <i>Serial Interface Timing</i> section	9
• Changed descriptions of RX_ANA_SUP, RX_DIG_SUP, and TX_CTRL_SUP pins in Pin Descriptions table	12
• Added Figure 12 , INPUT-REFERRED NOISE CURRENT vs PLETH CURRENT (BW = 5 Hz, PRF = 5000 Hz)	14
• Added Figure 18 , INPUT-REFERRED NOISE CURRENT vs PLETH CURRENT (BW = 20 Hz, PRF = 5000 Hz)	15
• Added Figure 24 , NOISE-FREE BITS vs PLETH CURRENT (BW = 5 Hz, PRF = 5000 Hz)	16
• Added Figure 30 , NOISE-FREE BITS vs PLETH CURRENT (BW = 20 Hz, PRF = 5000 Hz)	17
• Added Figure 52	20
• Updated Figure 53	22
• Changed name of register 15h	48
• Changed name of ADCRSTSTCT0 register	57
• Added note to descriptions of LED2-ALED2VAL and LED1-ALED1VAL registers	68

Changes from Revision B (February 2013) to Revision C	Page
• Changed first two sub-bullets of <i>Receive Channel with High Dynamic Range Features</i> bullet	1
• Changed ESD ratings specification values in Absolute Maximum Ratings table	2
• Added Performance, <i>PSRR</i> parameter to Electrical Characteristics table	4
• Changed Performance, <i>Total integrated noise current</i> and N_{FB} parameters in Electrical Characteristics table	4
• Changed first row of Receiver Functional Block Level Specification, <i>Total integrated noise current</i> parameter in Electrical Characteristics table	4
• Changed Ambient Cancellation Stage, <i>Gain</i> parameter specifications in Electrical Characteristics table	5
• Changed Transmitter, <i>Transmitter noise dynamic range</i> parameter in Electrical Characteristics table	5
• Added External Clock, <i>External clock input frequency</i> parameter to Electrical Characteristics table	6
• Added Timing, <i>Wake-up time from Rx power-down</i> and <i>Wake-up time from Tx power-down</i> parameters to Electrical Characteristics table	6
• Changed Supply Current section of Electrical Characteristics table	7
• Changed typical specification in first row and unit in second row of Power Dissipation, $P_{D(q)}$ parameter in Electrical Characteristics table	8
• Changed Power Dissipation, <i>After reset</i> LED_DRV_SUP typical specification in Electrical Characteristics table	8
• Changed Power Dissipation, <i>With stage 2 mode enabled</i> LED_DRV_SUP, TX_CTRL_SUP, and RX_DIG_SUP typical specifications in Electrical Characteristics table	8
• Changed pin out figure	11
• Added Figure 11	14
• Deleted Figure 11 , INPUT-REFERRED NOISE CURRENT vs PLETH CURRENT (BW = 5 Hz, PRF = 5000 Hz)	14
• Deleted Figure 17 , INPUT-REFERRED NOISE CURRENT vs PLETH CURRENT (BW = 20 Hz, PRF = 5000 Hz)	15
• Added Figure 22	15
• Deleted Figure 23 , NOISE-FREE BITS vs PLETH CURRENT (BW = 5 Hz, PRF = 5000 Hz)	16
• Added Figure 22	16

• Deleted Figure 29, NOISE-FREE BITS vs PLETH CURRENT (BW = 20 Hz, PRF = 5000 Hz)	17
• Added Figure 36 through Figure 39	18
• Added Figure 47 to Figure 51	20
• Changed gain setting range in <i>Receiver Front-End</i> section	23
• Changed corresponding register column description in rows t_{24} , t_{26} , and t_{28} in Table 2	31
• Added text reference for Figure 63 in <i>ADC Operation and Averaging Module</i> section	34
• Changed last paragraph of <i>AFE Analog Output Mode (ADC Bypass Mode)</i> section	38
• Changed description of <i>LED Power Reduction During Periods of Inactivity</i> section	42
• Updated Figure 75	43
• Updated Figure 76	44
• Changed LED2CONVEND register name in Table 4	48
• Changed RESERVED1 and RESERVED2 register descriptions in Table 4	49
• Changed description of bits D[15:0] in LED2STC register	50
• Changed description of bits D[15:0] in LED2ENDC, LED2LEDSTC, and LED2LEDENDC registers	51
• Changed description of bits D[15:0] in ALED2STC, ALED2ENDC, and LED1STC registers	52
• Changed description of bits D[15:0] in LED1ENDC, LED1LEDSTC, and LED1LEDENDC registers	53
• Changed description of bits D[15:0] in ALED1STC, ALED1ENDC, and LED2CONVST registers	54
• Changed LED2CONVEND register	55
• Changed description of bits D[15:0] in ALED2CONVST and ALED2CONVEND registers	55
• Changed description of bits D[15:0] in LED1CONVST, LED1CONVEND, and ALED1CONVST registers	56
• Changed description of bits D[15:0] in ALED1CONVEND register	57
• Changed $\overline{\text{RESET}}$ to RESET in ADCRSTSTCT0 and ADCRSTENDCT0 registers	57
• Changed $\overline{\text{RESET}}$ to RESET in ADCRSTSTCT1, ADCRSTENDCT1, and ADCRSTSTCT2 registers	58
• Changed $\overline{\text{RESET}}$ to RESET in ADCRSTENDCT2, ADCRSTSTCT3, and ADCRSTENDCT3 registers	59
• Added footnote to Table 6	63
• Changed bits D18 and D17 names in CONTROL2 bit register	64
• Added note to description of bits D[18:17] in CONTROL2 register	64
• Changed RESERVED1 and RESERVED2 registers	66

PACKAGING INFORMATION

Orderable Device	Status (1)	Package Type	Package Drawing	Pins	Package Qty	Eco Plan (2)	Lead/Ball Finish	MSL Peak Temp (3)	Op Temp (°C)	Top-Side Markings (4)	Samples
AFE4490RHAR	ACTIVE	VQFN	RHA	40	2500	Green (RoHS & no Sb/Br)	CU NIPDAU	Level-3-260C-168 HR	0 to 70	AFE4490	Samples
AFE4490RHAT	ACTIVE	VQFN	RHA	40	250	Green (RoHS & no Sb/Br)	CU NIPDAU	Level-3-260C-168 HR	0 to 70	AFE4490	Samples

(1) The marketing status values are defined as follows:

ACTIVE: Product device recommended for new designs.

LIFEBUY: TI has announced that the device will be discontinued, and a lifetime-buy period is in effect.

NRND: Not recommended for new designs. Device is in production to support existing customers, but TI does not recommend using this part in a new design.

PREVIEW: Device has been announced but is not in production. Samples may or may not be available.

OBSOLETE: TI has discontinued the production of the device.

(2) Eco Plan - The planned eco-friendly classification: Pb-Free (RoHS), Pb-Free (RoHS Exempt), or Green (RoHS & no Sb/Br) - please check <http://www.ti.com/productcontent> for the latest availability information and additional product content details.

TBD: The Pb-Free/Green conversion plan has not been defined.

Pb-Free (RoHS): TI's terms "Lead-Free" or "Pb-Free" mean semiconductor products that are compatible with the current RoHS requirements for all 6 substances, including the requirement that lead not exceed 0.1% by weight in homogeneous materials. Where designed to be soldered at high temperatures, TI Pb-Free products are suitable for use in specified lead-free processes.

Pb-Free (RoHS Exempt): This component has a RoHS exemption for either 1) lead-based flip-chip solder bumps used between the die and package, or 2) lead-based die adhesive used between the die and leadframe. The component is otherwise considered Pb-Free (RoHS compatible) as defined above.

Green (RoHS & no Sb/Br): TI defines "Green" to mean Pb-Free (RoHS compatible), and free of Bromine (Br) and Antimony (Sb) based flame retardants (Br or Sb do not exceed 0.1% by weight in homogeneous material)

(3) MSL, Peak Temp. -- The Moisture Sensitivity Level rating according to the JEDEC industry standard classifications, and peak solder temperature.

(4) Multiple Top-Side Markings will be inside parentheses. Only one Top-Side Marking contained in parentheses and separated by a "~" will appear on a device. If a line is indented then it is a continuation of the previous line and the two combined represent the entire Top-Side Marking for that device.

Important Information and Disclaimer: The information provided on this page represents TI's knowledge and belief as of the date that it is provided. TI bases its knowledge and belief on information provided by third parties, and makes no representation or warranty as to the accuracy of such information. Efforts are underway to better integrate information from third parties. TI has taken and continues to take reasonable steps to provide representative and accurate information but may not have conducted destructive testing or chemical analysis on incoming materials and chemicals. TI and TI suppliers consider certain information to be proprietary, and thus CAS numbers and other limited information may not be available for release.

In no event shall TI's liability arising out of such information exceed the total purchase price of the TI part(s) at issue in this document sold by TI to Customer on an annual basis.

TAPE AND REEL INFORMATION



QUADRANT ASSIGNMENTS FOR PIN 1 ORIENTATION IN TAPE



*All dimensions are nominal

Device	Package Type	Package Drawing	Pins	SPQ	Reel Diameter (mm)	Reel Width W1 (mm)	A0 (mm)	B0 (mm)	K0 (mm)	P1 (mm)	W (mm)	Pin1 Quadrant
AFE4490RHAR	VQFN	RHA	40	2500	330.0	16.4	6.3	6.3	1.5	12.0	16.0	Q2
AFE4490RHAT	VQFN	RHA	40	250	180.0	16.4	6.3	6.3	1.5	12.0	16.0	Q2

TAPE AND REEL BOX DIMENSIONS

*All dimensions are nominal

Device	Package Type	Package Drawing	Pins	SPQ	Length (mm)	Width (mm)	Height (mm)
AFE4490RHAR	VQFN	RHA	40	2500	367.0	367.0	38.0
AFE4490RHAT	VQFN	RHA	40	250	210.0	185.0	35.0

RHA (S-PVQFN-N40)

PLASTIC QUAD FLATPACK NO-LEAD

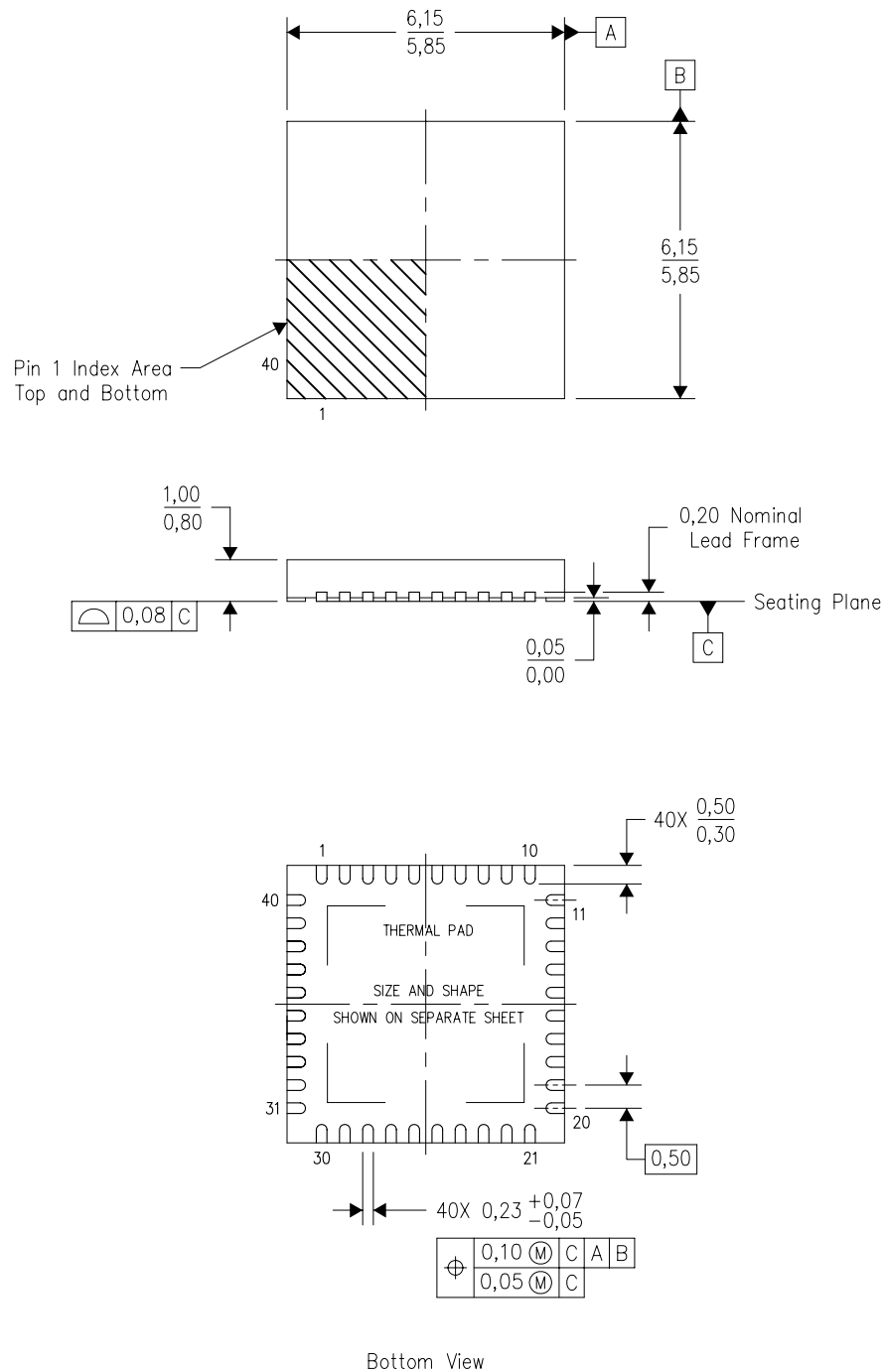

Bottom View

4204276/E 06/11

- NOTES:
- A. All linear dimensions are in millimeters. Dimensioning and tolerancing per ASME Y14.5M-1994.
 - B. This drawing is subject to change without notice.
 - C. QFN (Quad Flatpack No-Lead) Package configuration.
 - D. The package thermal pad must be soldered to the board for thermal and mechanical performance.
 - E. See the additional figure in the Product Data Sheet for details regarding the exposed thermal pad features and dimensions.
 - F. Package complies to JEDEC MO-220 variation VJJD-2.

THERMAL PAD MECHANICAL DATA

RHA (S-PVQFN-N40)

PLASTIC QUAD FLATPACK NO-LEAD

THERMAL INFORMATION

This package incorporates an exposed thermal pad that is designed to be attached directly to an external heatsink. The thermal pad must be soldered directly to the printed circuit board (PCB). After soldering, the PCB can be used as a heatsink. In addition, through the use of thermal vias, the thermal pad can be attached directly to the appropriate copper plane shown in the electrical schematic for the device, or alternatively, can be attached to a special heatsink structure designed into the PCB. This design optimizes the heat transfer from the integrated circuit (IC).

For information on the Quad Flatpack No-Lead (QFN) package and its advantages, refer to Application Report, QFN/SON PCB Attachment, Texas Instruments Literature No. SLUA271. This document is available at www.ti.com.

The exposed thermal pad dimensions for this package are shown in the following illustration.

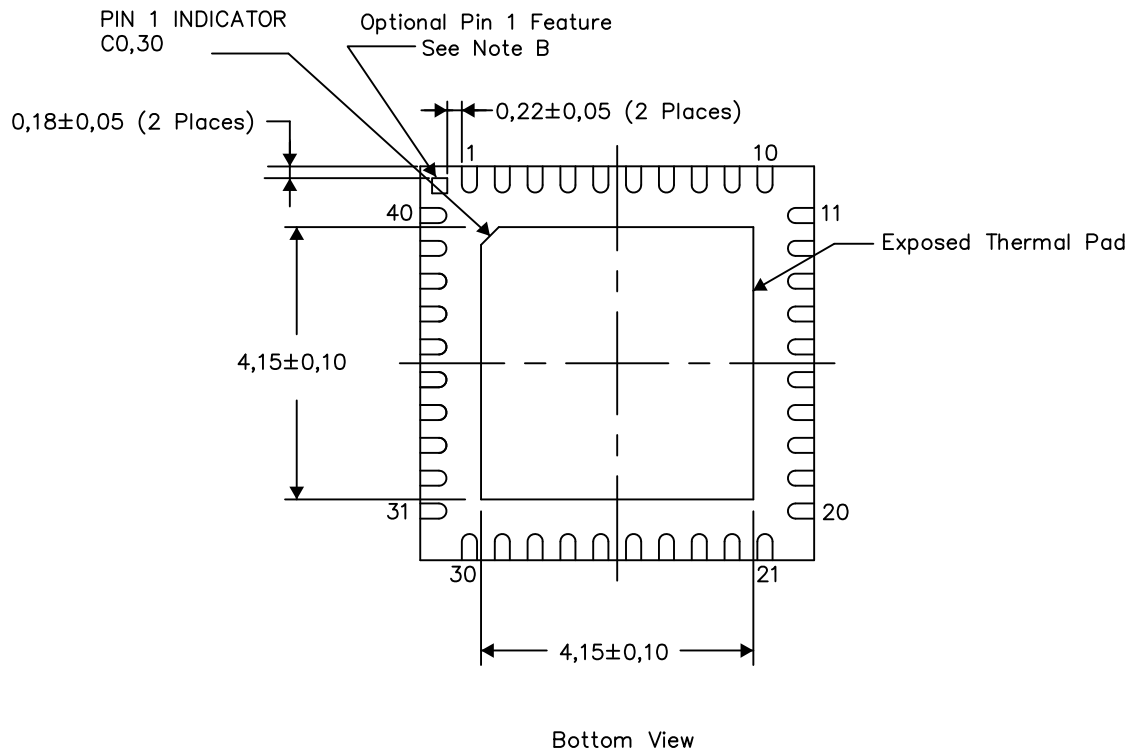

Exposed Thermal Pad Dimensions

4206355-2/U 12/12

- NOTES: A. All linear dimensions are in millimeters
- B. The Pin 1 Identification mark is an optional feature that may be present on some devices. In addition, this Pin 1 feature if present is electrically connected to the center thermal pad and therefore should be considered when routing the board layout.

RHA (S-PVQFN-N40)

PLASTIC QUAD FLATPACK NO-LEAD

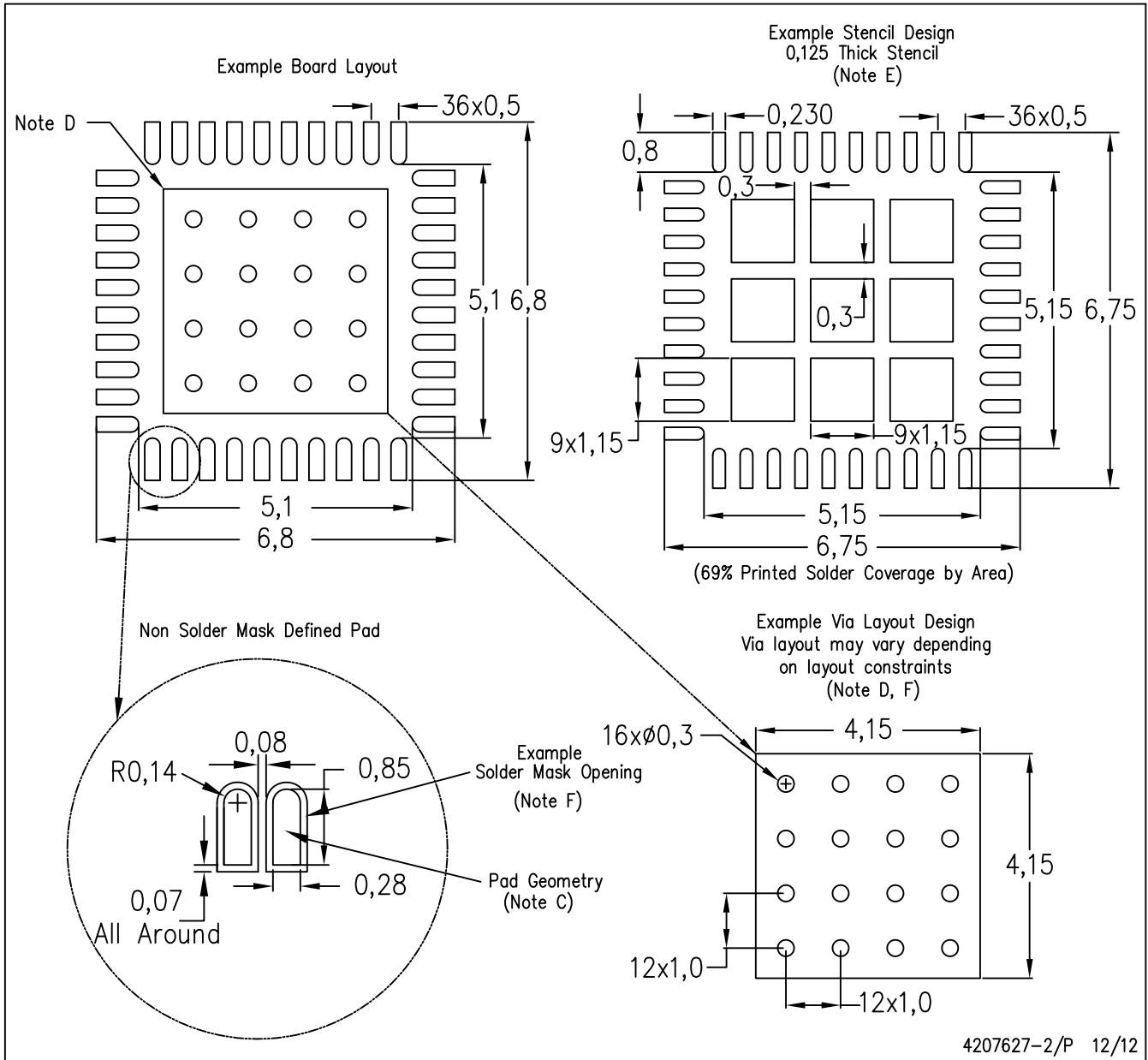

- NOTES:
- All linear dimensions are in millimeters.
 - This drawing is subject to change without notice.
 - Publication IPC-7351 is recommended for alternate designs.
 - This package is designed to be soldered to a thermal pad on the board. Refer to Application Note, Quad Flat-Pack Packages, Texas Instruments Literature No. SLUA271, and also the Product Data Sheets for specific thermal information, via requirements, and recommended board layout. These documents are available at www.ti.com <<http://www.ti.com>>.
 - Laser cutting apertures with trapezoidal walls and also rounding corners will offer better paste release. Customers should contact their board assembly site for stencil design recommendations. Refer to IPC 7525 for stencil design considerations.
 - Customers should contact their board fabrication site for recommended solder mask tolerances and via tenting recommendations for vias placed in the thermal pad.

IMPORTANT NOTICE

Texas Instruments Incorporated and its subsidiaries (TI) reserve the right to make corrections, enhancements, improvements and other changes to its semiconductor products and services per JESD46, latest issue, and to discontinue any product or service per JESD48, latest issue. Buyers should obtain the latest relevant information before placing orders and should verify that such information is current and complete. All semiconductor products (also referred to herein as "components") are sold subject to TI's terms and conditions of sale supplied at the time of order acknowledgment.

TI warrants performance of its components to the specifications applicable at the time of sale, in accordance with the warranty in TI's terms and conditions of sale of semiconductor products. Testing and other quality control techniques are used to the extent TI deems necessary to support this warranty. Except where mandated by applicable law, testing of all parameters of each component is not necessarily performed.

TI assumes no liability for applications assistance or the design of Buyers' products. Buyers are responsible for their products and applications using TI components. To minimize the risks associated with Buyers' products and applications, Buyers should provide adequate design and operating safeguards.

TI does not warrant or represent that any license, either express or implied, is granted under any patent right, copyright, mask work right, or other intellectual property right relating to any combination, machine, or process in which TI components or services are used. Information published by TI regarding third-party products or services does not constitute a license to use such products or services or a warranty or endorsement thereof. Use of such information may require a license from a third party under the patents or other intellectual property of the third party, or a license from TI under the patents or other intellectual property of TI.

Reproduction of significant portions of TI information in TI data books or data sheets is permissible only if reproduction is without alteration and is accompanied by all associated warranties, conditions, limitations, and notices. TI is not responsible or liable for such altered documentation. Information of third parties may be subject to additional restrictions.

Resale of TI components or services with statements different from or beyond the parameters stated by TI for that component or service voids all express and any implied warranties for the associated TI component or service and is an unfair and deceptive business practice. TI is not responsible or liable for any such statements.

Buyer acknowledges and agrees that it is solely responsible for compliance with all legal, regulatory and safety-related requirements concerning its products, and any use of TI components in its applications, notwithstanding any applications-related information or support that may be provided by TI. Buyer represents and agrees that it has all the necessary expertise to create and implement safeguards which anticipate dangerous consequences of failures, monitor failures and their consequences, lessen the likelihood of failures that might cause harm and take appropriate remedial actions. Buyer will fully indemnify TI and its representatives against any damages arising out of the use of any TI components in safety-critical applications.

In some cases, TI components may be promoted specifically to facilitate safety-related applications. With such components, TI's goal is to help enable customers to design and create their own end-product solutions that meet applicable functional safety standards and requirements. Nonetheless, such components are subject to these terms.

No TI components are authorized for use in FDA Class III (or similar life-critical medical equipment) unless authorized officers of the parties have executed a special agreement specifically governing such use.

Only those TI components which TI has specifically designated as military grade or "enhanced plastic" are designed and intended for use in military/aerospace applications or environments. Buyer acknowledges and agrees that any military or aerospace use of TI components which have **not** been so designated is solely at the Buyer's risk, and that Buyer is solely responsible for compliance with all legal and regulatory requirements in connection with such use.

TI has specifically designated certain components as meeting ISO/TS16949 requirements, mainly for automotive use. In any case of use of non-designated products, TI will not be responsible for any failure to meet ISO/TS16949.

Products

Audio	www.ti.com/audio
Amplifiers	amplifier.ti.com
Data Converters	dataconverter.ti.com
DLP® Products	www.dlp.com
DSP	dsp.ti.com
Clocks and Timers	www.ti.com/clocks
Interface	interface.ti.com
Logic	logic.ti.com
Power Mgmt	power.ti.com
Microcontrollers	microcontroller.ti.com
RFID	www.ti-rfid.com
OMAP Applications Processors	www.ti.com/omap
Wireless Connectivity	www.ti.com/wirelessconnectivity

Applications

Automotive and Transportation	www.ti.com/automotive
Communications and Telecom	www.ti.com/communications
Computers and Peripherals	www.ti.com/computers
Consumer Electronics	www.ti.com/consumer-apps
Energy and Lighting	www.ti.com/energy
Industrial	www.ti.com/industrial
Medical	www.ti.com/medical
Security	www.ti.com/security
Space, Avionics and Defense	www.ti.com/space-avionics-defense
Video and Imaging	www.ti.com/video

TI E2E Community

e2e.ti.com