

## CCD Analog Front-End with Timing Generator and Vertical Driver for Digital Cameras

### FEATURES

- **CCD Signal Processing:**
  - 36-MHz Correlated Double Sampling (CDS)
- **16-Bit Analog-to Digital Conversion:**
  - 36-MHz Conversion Rate
  - No Missing Codes Ensured
- **80-dB Input-Referred SNR (at 12-dB Gain)**
- **Programmable Black Level Clamping**
- **Programmable Gain Amplifier (PGA):**
  - –9 dB to +44 dB
  - –3 dB to +18 dB by Analog Front Gain
  - –6 dB to +26 dB by Digital Gain
- **Timing Generator:**
  - Fully Programmable  $V_{\text{RATE}}$  Timing by Serial I/O
  - Default Timing Supports Standard Operation
  - Flexible  $V_{\text{RATE}}$  Pin Assignment
  - HD/VD Master or Slave Mode
  - External Trigger, Strobe Function Support
  - Flexible Draft or Pixel Summing Operation
- **RG and HG Driver:**
  - Programmable Drivability Control
  - Two Horizontal Transfer Independent Drivers
  - One Reset Gate Driver
- **CCD Horizontal High-Speed Clock Phase Control:**
  - Fine Step: 0.28 ns
  - Wide Step: 1/3 Pixel Rate
- **Vertical CCD Driver:**
  - 8-Channel  $V_{\text{DRIVER}}$  with Sub-Driver
  - Supports Three-Field CCD Driving
  - Three Level Drivers ( $V_{\text{TRANSFER}} \times 5$ )
  - Two Level Drivers ( $V_{\text{TRANSFER}} \times 3$ )
  - Two Level Drivers ( $E_{\text{SHUTTER}} \times 1$ )
  - 450 pF to 1890 pF with 60  $\Omega$  to 240  $\Omega$
- **Flexible Voltage Operation:**
  - AFET + TG: 2.7 V to 3.6 V
  - VL: –5.0 V to –9.0 V
  - VM: GND
  - VH: 11.5 V to 15.5 V
  - Low Power: 139 mW at 3.0 V, 36 MHz
  - Stand-By + Power-Save Mode: 36 mW
  - Stand-By Mode (MCK Off): 10 mW
- **BGA-100 Package**

### DESCRIPTION

The VSP01M01 and VSP01M02 are complete mixed-signal ICs for charge-coupled device (CCD) signal processing with a built-in CCD timing generator, analog-to-digital converter (ADC), and CCD vertical driver. The AFE CCD channel has correlated double sampling to extract image information from the CCD output signal. Signal paths have gains ranging from –9 dB to +44 dB. The black level clamping circuit enables accurate black reference level and quick black level recovery after gain changes. An input signal clamp with CDS offset adjustment function is available. The system synchronizes the master clock, horizontal driver (HD), and vertical driver (VD). The VSP01M01 and VSP01M02 support all signal terminals required by CCD architecture. The RG driver, HG driver, and vertical driver synchronize the ADC clock phase in order to realize ideal performance.



Please be aware that an important notice concerning availability, standard warranty, and use in critical applications of Texas Instruments semiconductor products and disclaimers thereto appears at the end of this data sheet.



This integrated circuit can be damaged by ESD. Texas Instruments recommends that all integrated circuits be handled with appropriate precautions. Failure to observe proper handling and installation procedures can cause damage.

ESD damage can range from subtle performance degradation to complete device failure. Precision integrated circuits may be more susceptible to damage because very small parametric changes could cause the device not to meet its published specifications.

### PACKAGE/ORDERING INFORMATION<sup>(1)</sup>

PRODUCT	PACKAGE-LEAD	PACKAGE DESIGNATOR	SPECIFIED TEMPERATURE RANGE	PACKAGE MARKING	ORDERING NUMBER	TRANSPORT MEDIA, QUANTITY
VSP01M01ZWD <sup>(2)</sup>	BGA-100	ZWD	–25°C to +85°C	VSP01M01	VSP01M01ZWD	Tray, 360
					VSP01M01ZWDR	Tape and Reel
VSP01M01GWD	BGA-100	GWD	–25°C to +85°C	VSP01M01	VSP01M01GWD	Tray, 360
					VSP01M01GWDR	Tape and Reel
VSP01M02ZWD <sup>(2)</sup>	BGA-100	ZWD	–25°C to +85°C	VSP01M02	VSP01M02ZWD	Tray, 360
					VSP01M02ZWDR	Tape and Reel

(1) For the most current package and ordering information see the Package Option Addendum at the end of this document, or see the TI web site at [www.ti.com](http://www.ti.com).

(2) The package is Pb-free.

### ABSOLUTE MAXIMUM RATINGS<sup>(1)</sup>

Over operating free-air temperature range, unless otherwise noted.

PARAMETER	VSP01M01, VSP01M02	UNIT	
Supply voltage	AVDD	–0.3 to +4.0	V
	DRVDD	–0.3 to +4.0	V
	VDD5	–0.3 to +6.0	V
	VL	GND to –10	V
	VH	VL + 26	V
Supply voltage differences	AVDD, DRVDD	±0.1	V
Ground voltage differences	VSS	±0.1	V
Digital input voltage		–0.3 to (DVDD + 0.3)	V
Analog input voltage		–0.3 to (AVDD + 0.3)	V
Input current (any pins except supplies)		±10	mA
Ambient temperature under bias		–25 to +85	°C
Storage temperature		–55 to +125	°C
Junction temperature		+150	°C
Package temperature (IR reflow, peak)		+250	°C

(1) Stresses beyond those listed under absolute maximum ratings may cause permanent damage to the device. Exposure to absolute-maximum-rated conditions for extended periods may affect device reliability. These are stress ratings only and functional operation of the device at these or any other conditions beyond those indicated under recommended operating conditions is not implied.

### RECOMMENDED OPERATING CONDITIONS

Over operating free-air temperature range, unless otherwise noted.

PARAMETER		MIN	TYP	MAX	UNIT
Analog supply voltage	AVDD	2.7	3.0	3.6	V
	DRVDD	2.7	3.0	3.6	V
Digital supply voltage	VDD5	3.0		5.5	V
	VL	–9.0		–5.0	V
Driver supply voltage	VH	11.5		15.5	V
	Digital input logic family		CMOS		
Digital input clock frequency	MCK	12		36	MHz
	SCLK			20	MHz
Digital output load capacitance				10	pF
Operating free-air temperature	T <sub>A</sub>	–25		+85	°C

## ELECTRICAL CHARACTERISTICS

All specifications at  $T_A = +25^\circ\text{C}$ , all power supply voltages = +3.0 V, and conversion rate = 36 MHz, unless otherwise noted.

PARAMETER	TEST CONDITIONS	VSP01M01ZWD, VSP01M01GWD, VSP01M02ZWD			UNIT	
		MIN	TYP	MAX		
<b>RESOLUTION</b>						
Resolution	VSP01M01 only		10		Bits	
	VSP01M02 only		12		Bits	
<b>CONVERSION/CLOCK RATE</b>						
Conversion/clock rate				36	MHz	
<b>ANALOG INPUT (CCDIN)</b>						
Input signal level for full-scale out	CDS gain = 0 dB, DPGA gain = 0 dB			1000	mV	
Maximum input range	CDS gain = -3 dB, DPGA gain = 0 dB			1300	mV	
Input capacitance			15		pF	
Input limit		-0.3		3.3	V	
<b>TRANSFER CHARACTERISTICS</b>						
Differential nonlinearity	DNL	CDS gain = 0 dB, DPGA gain = 0 dB		±0.25	LSB	
Integral nonlinearity	INL	CDS gain = 0 dB, DPGA gain = 0 dB		±0.5	LSB	
No missing codes				Ensured		
Step response settling time		Full-scale step input		1	Pixel	
Overload recovery time		Step input from 1.8 V to 0 V		2	Pixels	
Data latency				9	Clocks	
Signal-to-noise ratio <sup>(1)</sup>		Grounded input capacitor, PGA gain = 0 dB		76	dB	
		Grounded input capacitor, analog gain = +12 dB		68	dB	
CCD offset correction range			-200	200	mV	
<b>INPUT CLAMP</b>						
Clamp on-resistance				400	Ω	
Clamp level				1.5	V	
<b>PROGRAMMABLE ANALOG FRONT GAIN (CDS)</b>						
Minimum gain		Gain code = 111b		-3	dB	
Default gain		Gain code = 000b		0	dB	
Medium gain 1		Gain code = 001b		6	dB	
Medium gain 2		Gain code = 010b		12	dB	
Maximum gain		Gain code = 011b		18	dB	
Gain control error				0.5	dB	
<b>PROGRAMMABLE DIGITAL GAIN (DPGA)</b>						
Programmable gain range				-6	26	dB
Gain step				0.03125		dB
<b>OPTICAL BLACK CLAMP LOOP</b>						
Control DAC resolution				10	Bits	
Loop time constant				40.7	μs	
Optical black clamp level (VSP01M01 only)		Programmable range of clamp level	16	78	LSB	
		OBCLP level at code = 01000b		32	LSB	
		OB level program step		2	LSB	
Optical black clamp level (VSP01M02 only)		Programmable range of clamp level	64	312	LSB	
		OBCLP level at code = 01000b		128	LSB	
		OB level program step		8	LSB	

(1) SNR = 20 log (full-scale voltage/rms noise).

### ELECTRICAL CHARACTERISTICS (continued)

All specifications at  $T_A = +25^\circ\text{C}$ , all power supply voltages = +3.0 V, and conversion rate = 36 MHz, unless otherwise noted.

PARAMETER		TEST CONDITIONS	VSP01M01ZWD, VSP01M01GWD, VSP01M02ZWD			UNIT
			MIN	TYP	MAX	
<b>DIGITAL INPUTS</b>						
Logic family				CMOS		
Input voltage	$V_{T+}$	Low to high threshold voltage		1.7		V
	$V_{T-}$	High to low threshold voltage		1.0		V
Input current	$I_{IH}$	Logic high, $V_{IN} = +3\text{ V}$		$\pm 20$		$\mu\text{A}$
	$I_{IL}$	Logic low, $V_{IN} = 0\text{ V}$		$\pm 20$		$\mu\text{A}$
Input capacitance				5		pF
Maximum input voltage				-0.3	DVDD + 0.3	V
<b>DIGITAL OUTPUTS (DATA)</b>						
Logic family				CMOS		
Logic coding				Straight Binary		
Output voltage	$V_{OH}$	Logic high		2.4		V
	$V_{OL}$	Logic low		0.4		V
Additional output data delay			Output data delay code = 00b	0		ns
			Output data delay code = 01b	2		ns
			Output data delay code = 10b	4		ns
			Output data delay code = 11b	6		ns
<b>H<sub>DRIVER</sub> OUTPUTS</b>						
Output voltage	RG, HL	Logic high ( $V_{OH}$ ) $I_{OH} = 0\text{ mA}$		VDD5 – 0.05		V
		Logic high ( $V_{OH}$ ) $I_{OH} = -6.8\text{ mA}$		VDD5 – 0.6		V
		Logic low ( $V_{OL}$ ) $I_{OL} = 6.8\text{ mA}$		0.4		V
Output voltage (HG1A, HG1B, HG2A, HG2B)		Logic high ( $V_{OH}$ ) $I_{OH} = 0\text{ mA}$		VDD5 – 0.05		V
		Logic high ( $V_{OH}$ ) $I_{OH} = -13.6\text{ mA (max)}$ , $-6.8\text{ mA (min)}$		VDD5 – 0.6		V
		Logic low ( $V_{OL}$ ) $I_{OL} = 13.6\text{ mA (max)}$ , $6.8\text{ mA (min)}$		0.4		V
<b>TG OUTPUTS</b>						
Output voltage (V0N-V12N, P0-P5, SUBN, FIELD, STROBE, MSHUT, SUBSW1, SUBSW2, ADCCK, HD, VD)		Logic high ( $V_{OH}$ ) $I_{OH} = -1.7\text{ mA}$		DVDD – 0.6		V
		Logic low ( $V_{OL}$ ) $I_{OL} = 1.7\text{ mA}$		0.4		V
TP output voltage (TPP, TPD)		Logic high ( $V_{OH}$ ) $I_{OH} = -1.7\text{ mA}$		DVDD – 0.6		V
		Logic low ( $V_{OL}$ ) $I_{OL} = 1.7\text{ mA}$		0.4		V
<b>V<sub>DRIVER</sub> OUTPUTS</b>						
Output current (V1, V2, V3A, V3B, V4, V5A, V5B, V6) ( $V_L = -9.0\text{ V}$ , $V_M = 0\text{ V}$ , $V_H = 15.5\text{ V}$ )	$I_{OL}$	V1, V2, V3A, V3B, V4, V5A, V5B, V6 = -8.1 V		10		mA
	$I_{OM1}$	V1, V2, V3A, V3B, V4, V5A, V5B, V6 = -0.2 V				mA
	$I_{OM2}$	V1, V3A, V3B, V5A, V5B = 0.2 V		5		mA
	$I_{OH}$	V1, V3A, V3B, V5A, V5B = 14.55 V				mA
	$I_{OSL}$	SUB = -8.1 V		5.4		mA
	$I_{OSH}$	SUB = 14.55 V				mA

## ELECTRICAL CHARACTERISTICS (continued)

All specifications at  $T_A = +25^\circ\text{C}$ , all power supply voltages = +3.0 V, and conversion rate = 36 MHz, unless otherwise noted.

PARAMETER		TEST CONDITIONS	VSP01M01ZWD, VSP01M01GWD, VSP01M02ZWD			UNIT
			MIN	TYP	MAX	
<b>POWER SUPPLY</b>						
Supply voltage	$AV_{DD}$		2.7	3.0	3.6	V
	$DV_{DD}$					
	VDD5	for HG1A, HG1B, HG2A, HG2B, HL, RG	3.0		5.5	V
	VL	for V1, V2, V3A, V3B, V4, V5A, V5B, V6	–9		–5	V
	VH	for V1, V2, V3A, V3B, V4, V5A, V5B, V6	11.5		15.5	V
Power dissipation	AFE	Normal operation mode: no CCD load (at 3.0 V, 38 MHz)	85			mW
Power dissipation	TG + H, $R_{DRIVER}$		50			mW
Power dissipation	$V_{DRIVER}$		4			mW
Power dissipation (total) without CCD load			139			mW
Power dissipation (total)			Standby + power-save mode (at 3.0 V, 38 MHz)	36		
		Master clock off mode (at 3.0 V)	10			mW
<b>TEMPERATURE RANGE</b>						
Operating temperature			–25		+85	$^\circ\text{C}$
Thermal resistance	$\theta_{JA}$	At 165 mW power dissipation with load	46.18			$^\circ\text{C}/\text{W}$

## SWITCHING CHARACTERISTICS

All specifications at  $T_A = +25^\circ\text{C}$ , all power supply voltages = +3.0 V, and conversion rate = 36 MHz, unless otherwise noted.

PARAMETER		TEST CONDITIONS	MIN	TYP	MAX	UNIT	
Propagation delay time	$t_{PLM}$			15	100	ns	
	$t_{PMH}$			20	100	ns	
	$t_{PLH}$			20	100	ns	
	$t_{PML}$			15	50	ns	
	$t_{PHM}$				30	50	ns
	$t_{PHL}$				30	50	ns
Rise time	$t_{TLM}$	VL → VM			300	ns	
	$t_{TMH}$	VM → VH			300	ns	
	$t_{TLH}$	VL → VH			300	ns	
Fall time	$t_{TML}$	VM → VL			300	ns	
	$t_{THM}$	VH → VM			300	ns	
	$t_{THL}$	VH → VL			300	ns	
Output noise voltage	$V_{CLH}$				2.0	V	
	$V_{CLL}$				2.0	V	
	$V_{CMH}$				2.0	V	
	$V_{CML}$				2.0	V	
	$V_{CHL}$				2.0	V	

**PIN CONFIGURATION**

**VSP01M01ZWD, VSP01M01GWD  
BGA PACKAGE  
(BOTTOM VIEW)**

	1	2	3	4	5	6	7	8	9	10
A	DAC1	V12N	CH2N	V6N	NC	V1N	V0N	NC	NC	CH0N
B	DAC2	V11N	V10N	V8N	V7N	CH1N	NC	CH3N	B8	NC
C	CCDIN	CCDGND	V9N	V3N	V4N	V2N	CH5N	B9	B6	B7
D	COB	BYP	BYP2	AVDD	DVSS	DVSS	DRVDD	CH4N	B4	B5
E	CM	BYPM	REFN	AVDD	AVSS	AVSS	DRVDD	B3	B1	B2
F	REFP	V5N	NC	AVDD	AVSS	AVSS	DRVDD	V2	B0	SUB
G	BYPD	V3B	TPD	DVSS	VL	VH	VDD5	VSS5	VSS5	NC
H	TPP	SYSRST	R <sub>LOAD</sub>	V5A	V3A	STROBE	VDD5	V6	RG	H1A
J	SDATA	SCLK	TRIG	VD	SUBSW1	MSHUT	SUBN	HL	V4	ADCCK
K	MCK	$\overline{CS}$	HD	SUBSW2	V1	FIELD	V5B	H2A	H1B	H2B

**PIN CONFIGURATION**

**VSP01M02ZWD  
BGA PACKAGE  
(BOTTOM VIEW)**

	1	2	3	4	5	6	7	8	9	10
A	DAC1	V12N	CH2N	V6N	NC	V1N	V0N	NC	NC	CH0N
B	DAC2	V11N	V10N	V8N	V7N	CH1N	NC	CH3N	B10	B1
C	CCDIN	CCDGND	V9N	V3N	V4N	V2N	CH5N	B11	B8	B9
D	COB	BYP	BYP2	AVDD	DVSS	DVSS	DRVDD	CH4N	B6	B7
E	CM	BYPM	REFN	AVDD	AVSS	AVSS	DRVDD	B5	B3	B4
F	REFP	V5N	NC	AVDD	AVSS	AVSS	DRVDD	V2	B2	SUB
G	BYPD	V3B	TPD	DVSS	VL	VH	VDD5	VSS5	VSS5	B0
H	TPP	SYSRST	R <sub>LOAD</sub>	V5A	V3A	STROBE	VDD5	V6	RG	H1A
J	SDATA	SCLK	TRIG	VD	SUBSW1	MSHUT	SUBN	HL	V4	ADCCK
K	MCK	$\overline{CS}$	HD	SUBSW2	V1	FIELD	V5B	H2A	H1B	H2B

**Table 1. TERMINAL FUNCTIONS**

TERMINAL		TYPE <sup>(1)</sup>	DESCRIPTION
NAME	PIN		
DAC1	A1	DO	DAC1 output
V12N	A2	DO	Vertical rate signal 12N
CH2N	A3	DO	Universal vertical rate signal 2N (for V3A)
V6N	A4	DO	Vertical rate signal 6N (for V6)
NC	A5	—	No connection
V1N	A6	DO	Vertical rate signal 1N (for V1)
V0N	A7	DO	Vertical rate signal 0N
NC	A8	—	No connection
NC	A9	—	No connection
CH0N	A10	DO	Universal vertical rate signal 0N
DAC2	B1	DO	DAC2 output
V11N	B2	DO	Vertical rate signal 11N
V10N	B3	DO	Vertical rate signal 10N
V8N	B4	DO	Vertical rate signal 8N
V7N	B5	DO	Vertical rate signal 7N
CH1N	B6	DO	Universal vertical rate signal 1N (for V1)
NC	B7	—	No connection
CH3N	B8	DO	Universal vertical rate signal 3N (for V5A)
B8	B9	DO	Data out bit 8 (VSP01M01 only)
B10	B9	DO	Data out bit 10 (VSP01M02 only)
NC	B10	—	No connection (VSP01M01 only)
B1	B10	DO	Data out bit 1 (VSP01M02 only)
CCDIN	C1	AI	CCD signal input
CCDGND	C2	AI	CCD signal input ground
V9N	C3	DO	Vertical rate signal 9N
V3N	C4	DO	Vertical rate signal 3N (for V3A, V3B)
V4N	C5	DO	Vertical rate signal 4N (for V4)
V2N	C6	DO	Vertical rate signal 2N (for V2)
CH5N	C7	DO	Universal vertical rate signal 5N (for V5B)
B9	C8	DO	Data out bit 9 (MSB) (VSP01M01 only)
B11	C8	DO	Data out bit 11 (MSB) (VSP01M02 only)
B6	C9	DO	Data out bit 6 (VSP01M01 only)
B8	C9	DO	Data out bit 8 (VSP01M02 only)
B7	C10	DO	Data out bit 7 (VSP01M01 only)
B9	C10	DO	Data out bit 9 (VSP01M02 only)
COB	D1	AO	OB loop feedback capacitor <sup>(2)</sup>
BYP	D2	AO	Internal reference <sup>(3)</sup>
BYP2	D3	AO	Internal reference <sup>(4)</sup>
AVDD	D4	P	Analog power supply
DVSS	D5	P	Ground
DVSS	D6	P	Ground

(1) Designators by type: P: power-supply and ground, DI: digital input, DO: digital output, DI/O: digital input and output, AI: analog input, AO: analog output, and VDO:  $V_{DRIVER}$  digital output.

(2) Should be connected to ground with a bypass capacitor. The recommended value is 0.1  $\mu\text{F}$  to 0.22  $\mu\text{F}$ ; however, actual value depends on the application environment. Refer to the [OB Loop and OB Clamp Level](#) section for more detail.

(3) Should be connected to ground with a bypass capacitor (0.1  $\mu\text{F}$ ). Refer to the [Voltage Reference](#) section for more detail.

(4) Should be connected to ground with a bypass capacitor. The recommended value is 400 pF to 1000 pF; however, actual value depends on the application environment. Refer to the [Voltage Reference](#) section for more detail.

**Table 1. TERMINAL FUNCTIONS (continued)**

TERMINAL		TYPE <sup>(1)</sup>	DESCRIPTION
NAME	PIN		
DRVDD	D7	P	Digital output power supply
CH4N	D8	DO	Universal vertical rate signal 4N (for V3B)
B4	D9	DO	Data out bit 4 (VSP01M01 only)
B6	D9	DO	Data out bit 6 (VSP01M02 only)
B5	D10	DO	Data out bit 5 (VSP01M01 only)
B7	D10	DO	Data out bit 7 (VSP01M02 only)
CM	E1	AO	Internal reference <sup>(3)</sup>
BYPM	E2	AO	Internal reference <sup>(4)</sup>
REFN	E3	AO	Internal reference <sup>(3)</sup>
AVDD	E4	P	Analog power supply
AVSS	E5	P	Ground
AVSS	E6	P	Ground
DRVDD	E7	P	Digital output power supply
B3	E8	DO	Data out bit 3 (VSP01M01 only)
B5	E8	DO	Data out bit 5 (VSP01M02 only)
B1	E9	DO	Data out bit 1 (VSP01M01 only)
B3	E9	DO	Data out bit 3 (VSP01M02 only)
B2	E10	DO	Data out bit 2 (VSP01M01 only)
B4	E10	DO	Data out bit 4 (VSP01M02 only)
REFP	F1	AO	Internal reference <sup>(5)</sup>
V5N	F2	DO	Vertical rate signal 5N (for V5A, V5B)
NC	F3	—	No connection
AVDD	F4	P	Analog power supply
AVSS	F5	P	Ground
AVSS	F6	P	Ground
DRVDD	F7	P	Digital output power supply
V2	F8	VDO	V <sub>DRIVER</sub> out 2
B0	F9	DO	Data out bit 0 (LSB) (VSP01M01 only)
B2	F9	DO	Data out bit 2 (VSP01M02 only)
SUB	F10	VDO	V <sub>DRIVER</sub> out for CCD electric shutter
BYPD	G1	AO	DLL bypass <sup>(6)</sup>
V3B	G2	VDO	V <sub>DRIVER</sub> out 3B
TPD	G3	DO	Test pin for SHD, CLPDM, HDIV
DVSS	G4	P	Ground
VL	G5	P	V <sub>DRIVER</sub> power supply
VH	G6	P	V <sub>DRIVER</sub> power supply
VDD5	G7	P	Digital power supply
VSS5	G8	P	Digital ground
VSS5	G9	P	Digital ground
NC	G10	—	No connection (VSP01M01 only)
B0	G10	DO	Data out bit 0 (LSB) (VSP01M02 only)
TPP	H1	DO	Test pin for SHP, CLPOB, PBLK, HBLK
SYSRST	H2	DI	Asynchronous reset
R <sub>LOAD</sub>	H3	DI	Register load

(5) Should be connected to ground with a bypass capacitor (0.1  $\mu$ F). Refer to the [Voltage Reference](#) section for more detail.

(6) Should be connected to ground with a bypass capacitor. The recommended value is 1000 pF to 0.1  $\mu$ F; however, actual value depends on the application environment.



**Table 1. TERMINAL FUNCTIONS (continued)**

TERMINAL		TYPE <sup>(1)</sup>	DESCRIPTION
NAME	PIN		
V5A	H4	VDO	V <sub>DRIVER</sub> out 5A
V3A	H5	VDO	V <sub>DRIVER</sub> out 3A
STROBE	H6	DO	Strobe signal
VDD5	H7	P	Digital power supply
V6	H8	VDO	V <sub>DRIVER</sub> out 6
RG	H9	DO	CCD reset gate signal
H1A	H10	DO	CCD horizontal transfer signal 1A
SDATA	J1	DI	Serial data
SCLK	J2	DI	Serial data clock
TRIG	J3	DI	External trigger
VD	J4	DI/O	Vertical sync
SUBSW1	J5	DO	CCD substrate signal switch 1
MSHUT	J6	DO	Mechanical shutter signal
SUBN	J7	DO	CCD electric shutter (for SUB)
HL	J8	DO	CCD horizontal transfer signal
V4	J9	VDO	V <sub>DRIVER</sub> out 4
ADCK	J10	DO	Clock for digital output buffer
MCK	K1	DI	Master clock
$\overline{CS}$	K2	DI	Chip select
HD	K3	DI/O	Horizontal sync
SUBSW2	K4	DO	CCD substrate signal switch 2
V1	K5	VDO	V <sub>DRIVER</sub> out 1
FIELD	K6	DO	Field index signal
V5B	K7	VDO	V <sub>DRIVER</sub> out 5B
H2A	K8	DO	CCD horizontal transfer signal 2A
H1B	K9	DO	CCD horizontal transfer signal 1B
H2B	K10	DO	CCD horizontal transfer signal 2B

### FUNCTIONAL BLOCK DIAGRAM

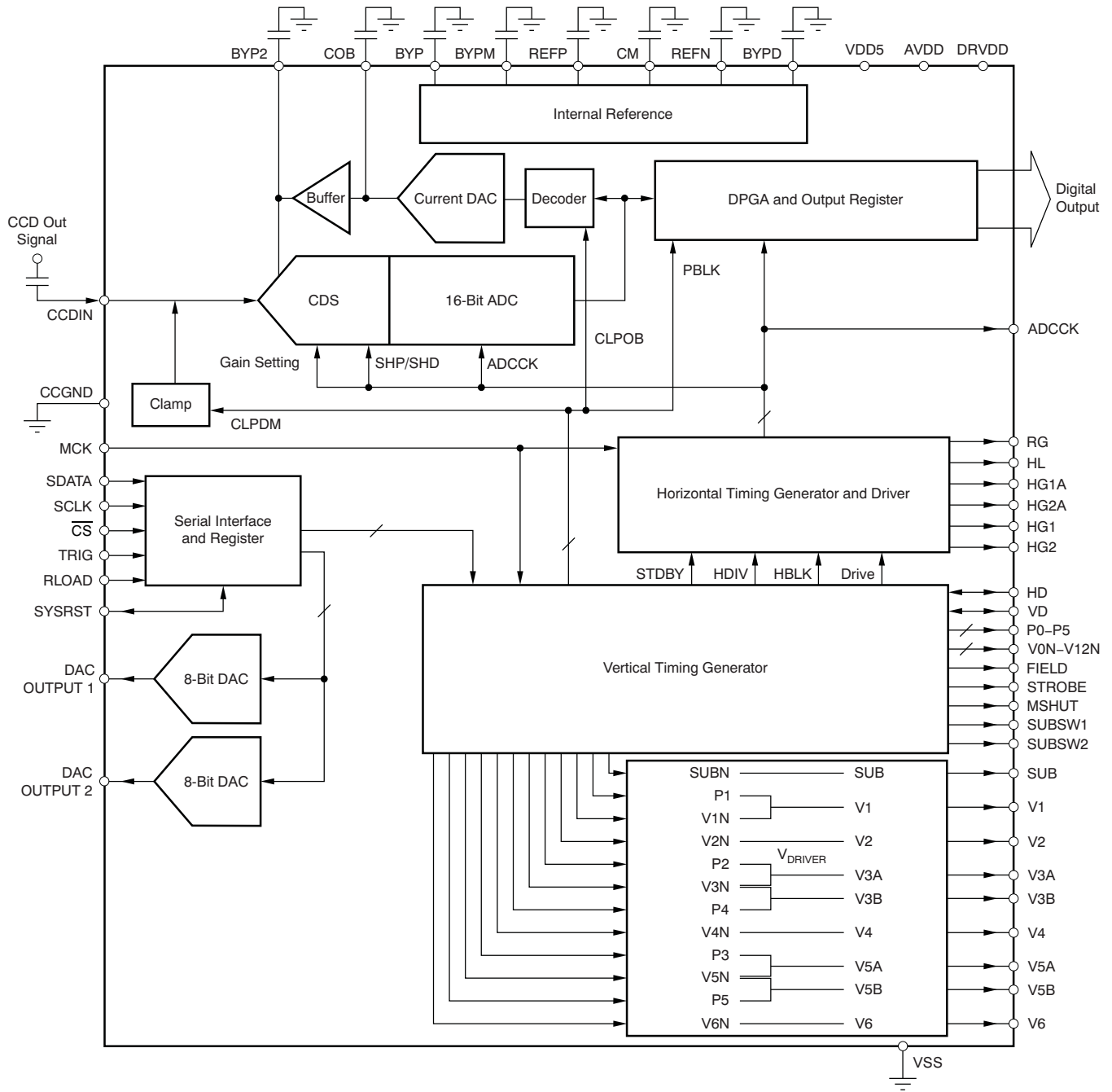

### TIMING CHARACTERISTICS

#### TG HIGH-SPEED PULSE TIMING

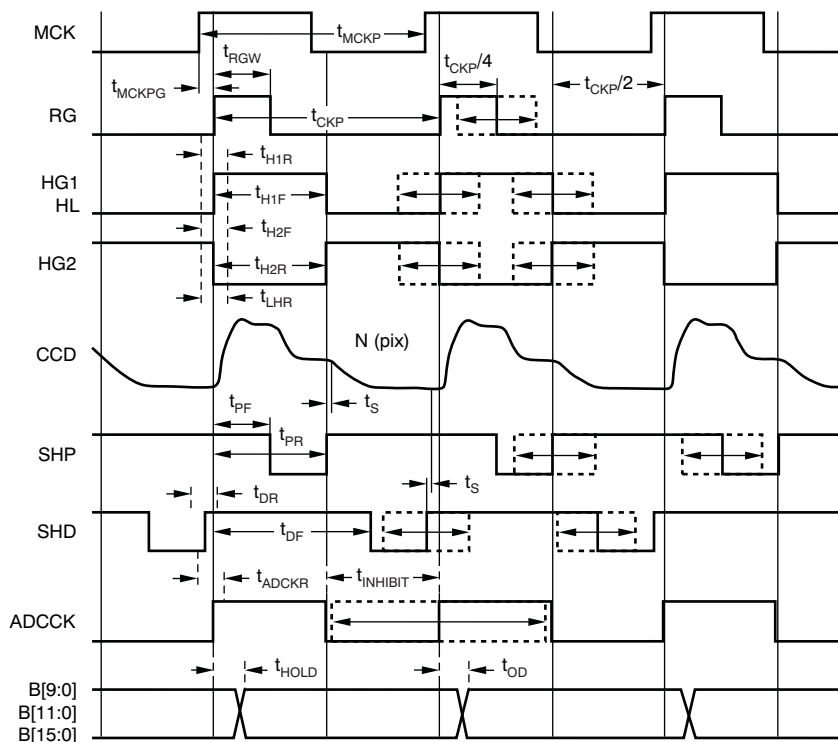

NOTE: Dashed lines indicate programmable parameters.

Figure 1. TG High-Speed Pulse Timing

**Table 2. Timing Characteristics for Figure 1**

PARAMETER		MIN	TYP	MAX	UNIT
$t_{MCKP}$	MCK clock period	27.7		83.3	ns
$t_{MCKRG}$	MCK rising edge to RG rising edge <sup>(1)</sup>		14		ns
$t_{CKP}$	Pixel rate	27.7		83.3	ns
$t_{RGW}$	RG rising edge to RG falling edge <sup>(2)</sup>	$t_{CKP}/4 - 16t_{CKP}/100$	$t_{CKP}/4$	$t_{CKP}/4 + 15t_{CKP}/100$	ns
$t_{H1R}$	RG rising edge to HG1 rising edge <sup>(2)</sup>	$-16t_{CKP}/100$	0	$15t_{CKP}/100$	ns
$t_{H1F}$	RG rising edge to HG1 falling edge <sup>(2)</sup>	$t_{CKP}/2 - 16t_{CKP}/100$	$t_{CKP}/2$	$t_{CKP}/2 + 15t_{CKP}/100$	ns
$t_{H2R}$	RG rising edge to HG2 rising edge <sup>(2)</sup>	$t_{CKP}/2 - 16t_{CKP}/100$	$t_{CKP}/2$	$t_{CKP}/2 + 15t_{CKP}/100$	ns
$t_{H2F}$	RG rising edge to HG2 falling edge <sup>(2)</sup>	$-16t_{CKP}/100$	0	$+15t_{CKP}/100$	ns
$t_{LHR}$	RG rising edge to HL rising edge <sup>(2)</sup>	$-16t_{CKP}/100$	0	$+15t_{CKP}/100$	ns
$t_{LHF}$	RG rising edge to HL falling edge <sup>(2)</sup>	$t_{CKP}/2 - 16t_{CKP}/100$	$t_{CKP}/2$	$t_{CKP}/2 + 15t_{CKP}/100$	ns
$t_{PF}$	RG rising edge to SHP falling edge <sup>(2)</sup>	$t_{CKP}/4 - 16t_{CKP}/100$	$t_{CKP}/4$	$t_{CKP}/4 + 15t_{CKP}/100 + 6$	ns
$t_{PR}$	RG rising edge to SHP rising edge <sup>(2)</sup>	$t_{CKP}/2 - 16t_{CKP}/100$	$t_{CKP}/2$	$t_{CKP}/2 + 15t_{CKP}/100 + 6$	ns
$t_{DF}$	RG rising edge to SHD falling edge <sup>(2)</sup>	$3t_{CKP}/4 - 24t_{CKP}/100$	$3t_{CKP}/4 - 8t_{CKP}/100$	$3t_{CKP}/4 + 7t_{CKP}/100 + 6$	ns
$t_{DR}$	RG rising edge to SHD rising edge <sup>(2)</sup>	$-24t_{CKP}/100$	$-8t_{CKP}/100$	$7t_{CKP}/100 + 6$	ns
$t_{ADCKR}$	RG rising edge to ADCCK rising edge <sup>(3)</sup>	$-50t_{CKP}/100$	0	$49t_{CKP}/100$	ns
$t_s$	Sampling delay for SHP and SHD		3		ns
$t_{INHIBIT}$	Inhibited clock period	4	7	10	ns
$t_{ADC}$	ADCCK duty		50		%
$t_{DOD}$	Data out delay (register setting 002h)	0	0	6	ns
$t_{HOLD}$	Output hold time	$2 + t_{DOD}$			ns
$t_{OD}$	Output delay (no load)	$27 + t_{DOD}$			ns
DL	Data latency	9 (fixed)			$t_{CKP}$ cycles

- (1) Pulse phase can be programmed through the serial interface.
- (2) RG pulse width can be programmed through the serial interface. Refer to the [High-Speed Pulse Adjustment](#) section of the [TG \(Timing Generator\) Section](#) for details.
- (3) ADCCK phase can also be programmed as a 90-degree step through the serial interface.

## SLAVE MODE: VD, HD SPECIFICATIONS

### VD, HD Detect

The odd field of the two-field CCD operation and the first field of the even field operation is detected by the VD and HD phase. The delay limit of the VD and HD phase is specified in [Figure 2](#) and [Figure 3](#).

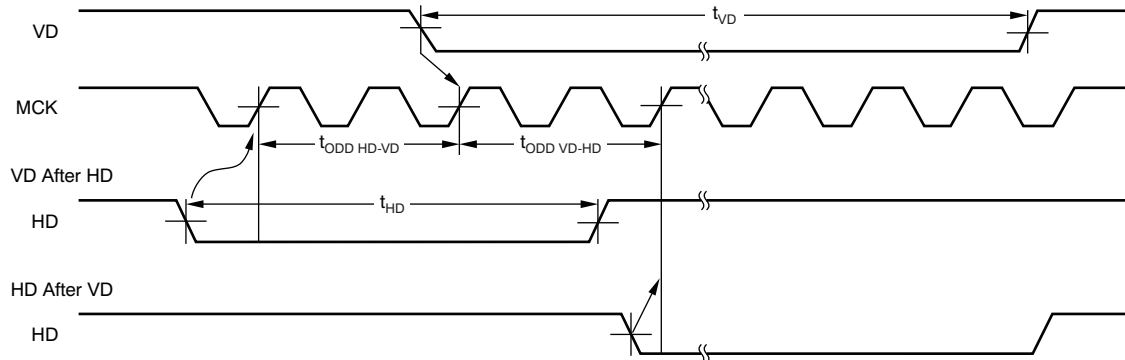

Figure 2. VD, HD Falling Edge Detect

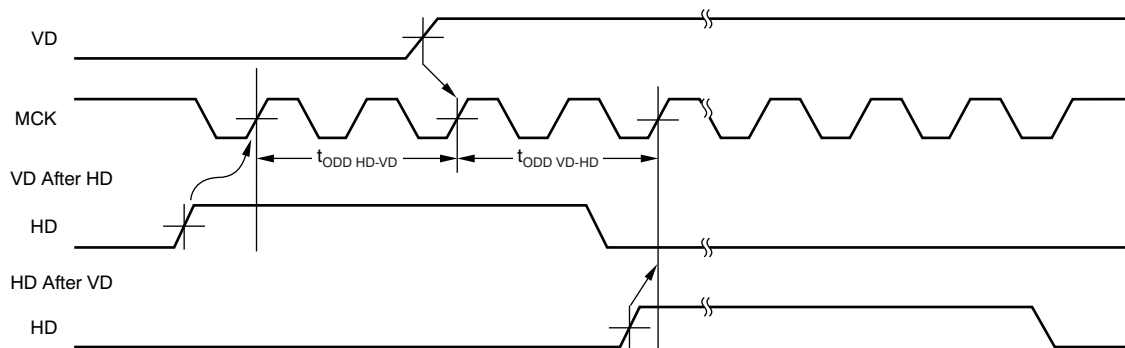

Figure 3. VD, HD Rising Edge Detect

Table 3. Timing Characteristics for [Figure 2](#) and [Figure 3](#)<sup>(1)</sup>

PARAMETER	MIN	TYP	MAX	UNIT
$t_{VD}$	10			$\tau$ (MCK cycles)
$t_{HD}$	10			$\tau$ (MCK cycles)
$t_{ODD\ HD-VD}$	0	1	6	$\tau$ (MCK cycles)
$t_{ODD\ VD-HD}$	0	1	6	$\tau$ (MCK cycles)

(1) The VD, HD edge is detected by the rising edge of MCK.

**H<sub>COUNTER</sub> Reset**

H<sub>COUNTER</sub> is reset via HD detection. The timing is shown in Figure 4 and Figure 5.

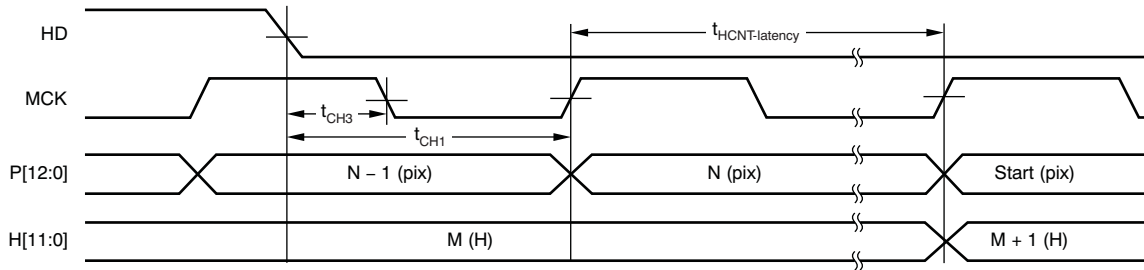

**Figure 4. HD Falling Edge Detect**

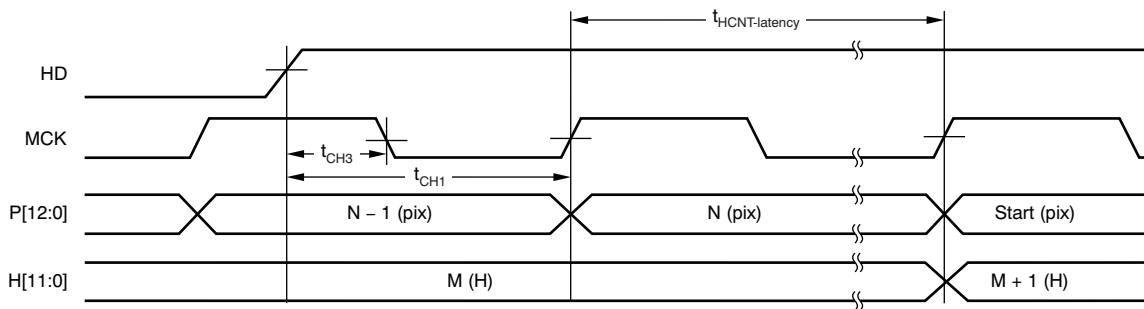

**Figure 5. HD Rising Edge Detect**

**Table 4. Timing Characteristics for Figure 4 and Figure 5<sup>(1)</sup>**

PARAMETER		REGISTER		MIN	TYP	MAX	UNIT
		VD, HD EDGE 020h[3]	MCK EDGE 020h[2]				
t <sub>CH1</sub>	HD falling edge to MCK rising edge	0 (falling)	0 (rising)	-6		1	ns
t <sub>CH2</sub>	HD rising edge to MCK rising edge	1 (rising)	0 (rising)	-6		1	ns
t <sub>CH3</sub>	HD falling edge to MCK falling edge	0 (falling)	1 (falling)	-4		3	ns
t <sub>CH4</sub>	HD rising edge to MCK falling edge	1 (rising)	1 (falling)	-4		3	ns
t <sub>HCNT-LATENCY</sub>	H <sub>COUNTER</sub> reset latency (register setting 034h[3:0])	—	—		6		τ (MCK cycles)

(1) H<sub>COUNTER</sub> reset timing is selected by MCK edge polarity.

## MASTER MODE: HD, VD SPECIFICATIONS

The HD, VD MCK timing is shown in [Figure 6](#) and [Figure 7](#).

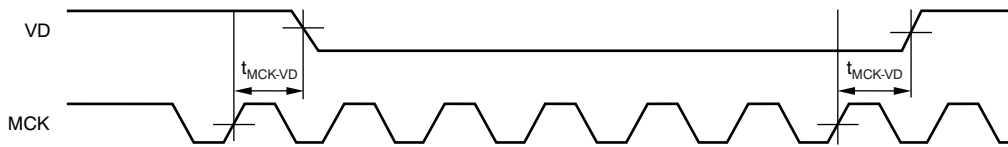

Figure 6. VD MCK Specification

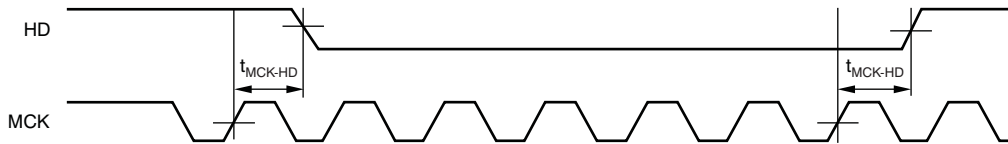

Figure 7. HD MCK Specification

Table 5. Timing Characteristics for [Figure 6](#) and [Figure 7](#)

PARAMETER	MIN	TYP	MAX	UNIT
$t_{MCK-VD}$	MCK rising edge to VD falling edge	10		ns
$t_{MCK-HD}$	MCK rising edge to HD falling edge	10		ns

## SERIAL INTERFACE TIMING SPECIFICATION

The serial interface has two writing modes: standard and continuous write. These modes are shown in [Figure 8](#) and [Figure 9](#).

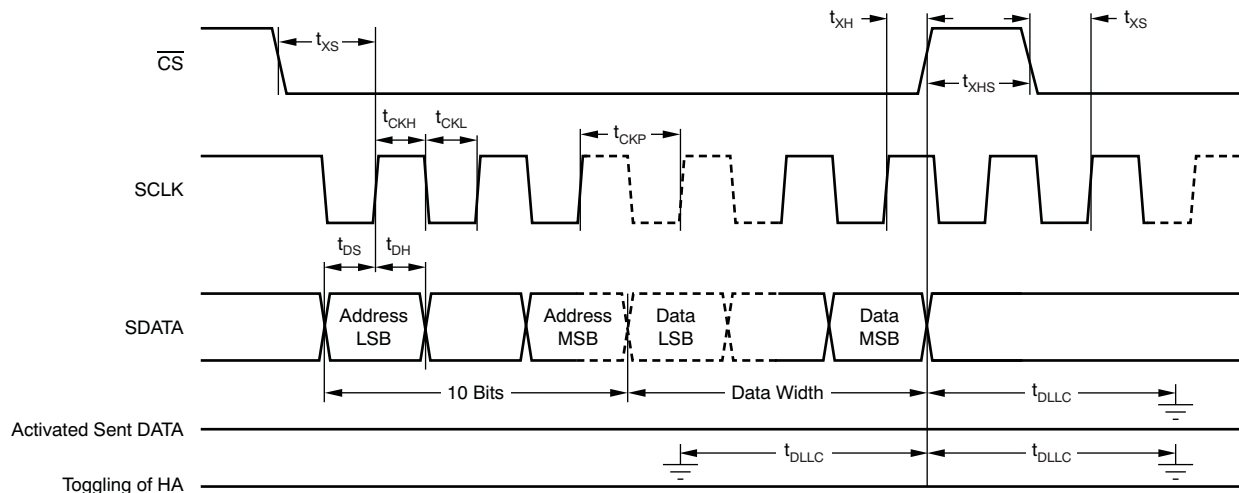

Figure 8. Standard Mode Timing

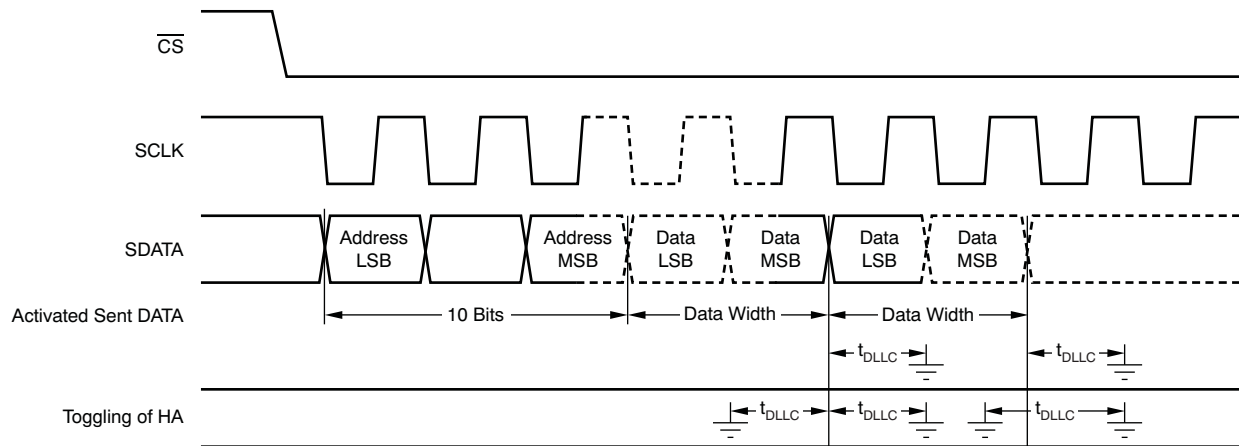

Figure 9. Continuous Write Mode Timing

Table 6. Timing Characteristics for Figure 8 and Figure 9

PARAMETER	MIN	TYP	MAX	UNIT
$t_{CKP}$	50			ns
$t_{CKH}$	25			ns
$t_{CKL}$	25			ns
$t_{DS}$	15			ns
$t_{DH}$	15			ns
$t_{XS}$	20			ns
$t_{XH}$	20			ns
$t_{XHS}$	20			ns
$t_{DLLC}$			10	MCK CLK

Data shift operation should decode at the rising edges of SCLK while  $\overline{CS}$  is low.

Parallel latch timing for each mode is described in Table 7.

Table 7. Parallel Latch

MODE	PARALLEL LATCH TIMING
Standard write	Rising edge of $\overline{CS}$
Continuous write	End of data (MSB)

In addition to the parallel latch, there are several registers dedicated to the specific features of the device; these registers are synchronized with MCK. It takes less than 10 clock cycles for the data in the parallel latch to be written to these registers. Therefore, to complete the data updates, it requires less than 10 clock cycles after parallel latching.

Toggling of HA is inhibited from parallel latch. Refer to the *Serial interface (SPI)* section of the *Common Section* for details.



### EQUIVALENT CIRCUITS

Figure 10 shows the HG1A, HG1B, HG2A, and HG2B high-speed driver and load model. The driver supports up to 150 pF. Figure 11 shows the RG and HL high-speed driver and load model. The driver supports up to 10 pF.

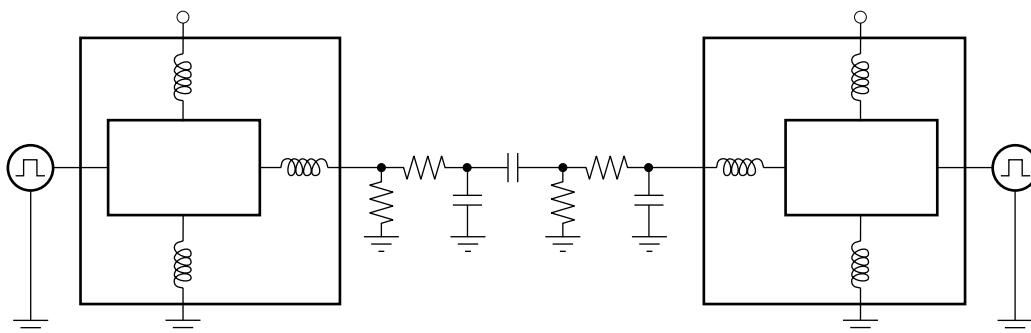

Figure 10. HG Driver and Load Model

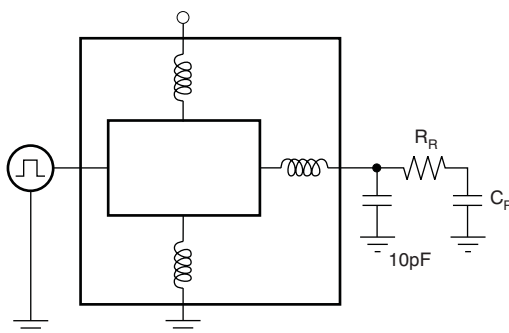
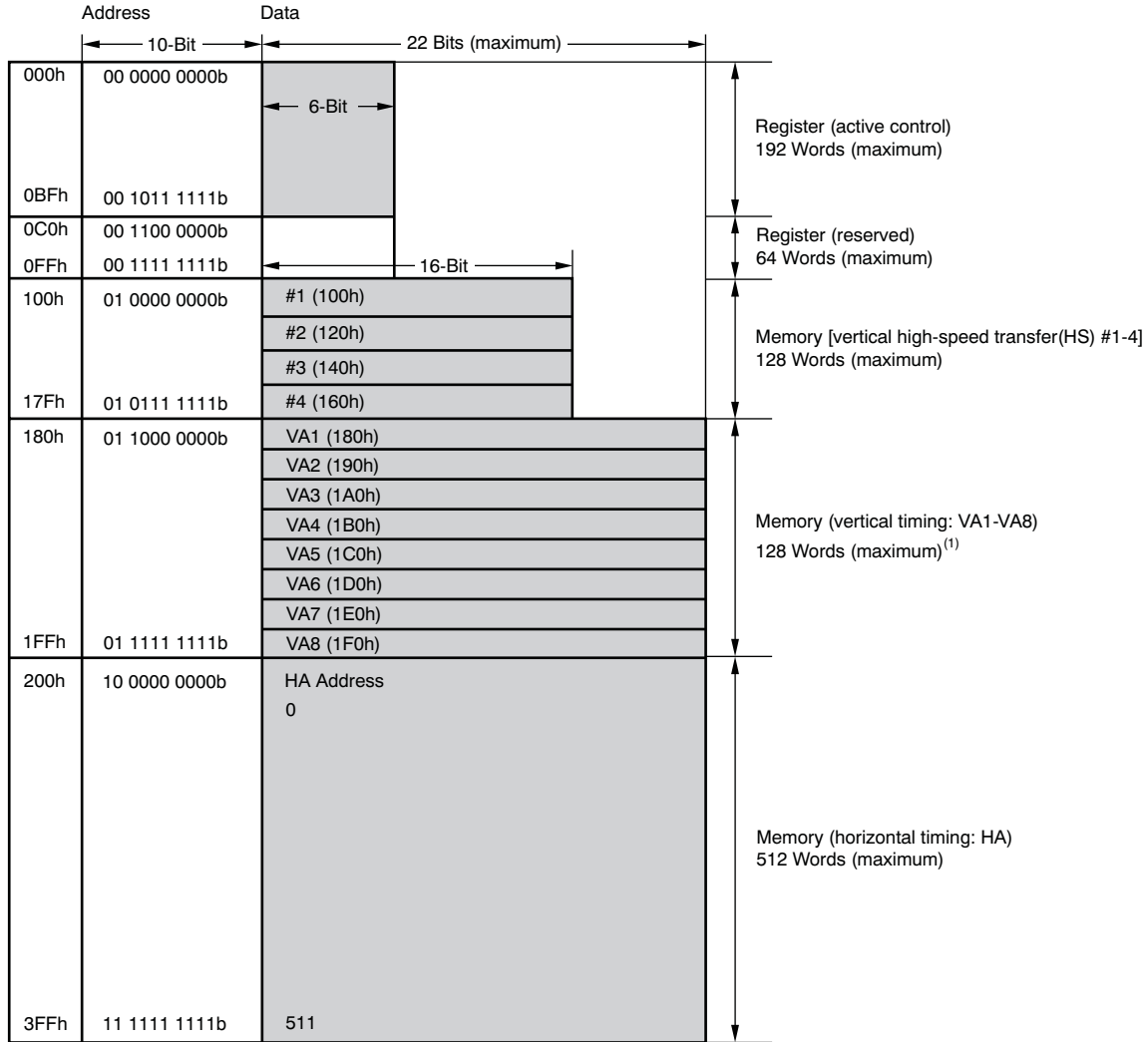

Figure 11. RG Driver and Load Model

COMMON SECTION

REGISTER/MEMORY MAP

Figure 12 shows the TG register/memory map, which has 1024 words of 32-bit instruction (max). The 256-word register area enables active instruction, which requires dynamic operation. The 768-word memory area enables static instruction, which is almost fixed during a frame rate.



NOTE: Shaded cells indicate the area under discussion.

(1) Refer to the *TG Instruction Hierarchy* section of the *TG (Timing Generator) Section* for details.

Figure 12. VSP01M01/VSP01M02 TG Register/Memory Map

## SERIAL INTERFACE (SPI)

The SPI functions and timings are controlled through the serial interface, which is composed of three signals: SDATA, SCLK, and  $\overline{CS}$ . SDATA data are sequentially stored to the shift register at the rising edge of SCLK. Before a write operation,  $\overline{CS}$  must go low, and remain low during writing. Refer to [Serial Interface Timing Specification](#) for further details.

The serial interface command is composed of a 10-bit address and 6-bit, 16-bit, or 22-bit data. [Table 8](#) shows the data width for each address area.

**Table 8. Address Data Width<sup>(1)</sup>**

ADDRESS (10-Bit)	DATA WIDTH (Bits)	USAGE
000h-0BFh	6	Register
100h-17Fh	16	HS memory
180h-3FFh	22	HA and VA memory

(1) Refer to [Register/Memory Map](#) for details.

The SPI has two write modes: standard and continuous.

### Standard Write Mode

The VSP01M01 and VSP01M02 support a standard write mode, as shown in [Figure 13](#). Normally, a serial interface command is sent by one address and data combination. The 10-bit address should primarily be sent LSB first; the following 6-bit, 16-bit, or 22-bit data should also sent LSB first. 6-bit, 16-bit, or 22-bit data are stored in the respective register by the 10-bit address at the rising edge of  $\overline{CS}$ . The stored serial command data change immediately at rising edge of  $\overline{CS}$  or are reserved by programmable control. If the data bit does not contain either 6-bits, 16-bits, or 22-bits at the end of the data stream, any empty data bits are ignored.

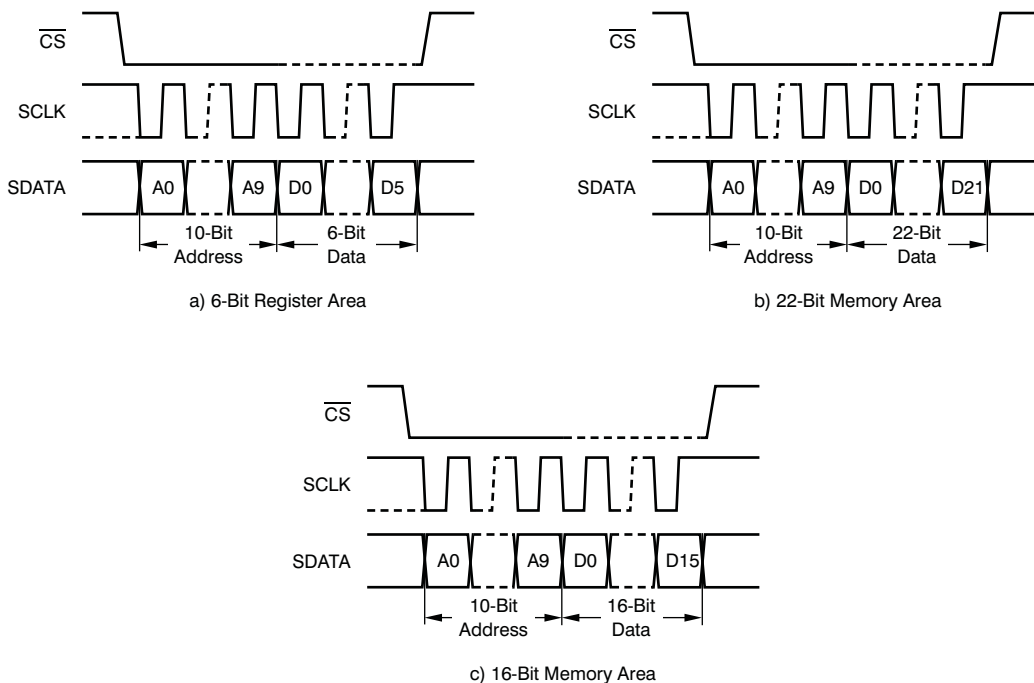

**Figure 13. SPI Standard Write Mode**

### Continuous Write Mode

These devices also support a continuous write mode, as shown in Figure 14. When the input serial data are longer than one set of instructions, the following data stream is automatically recognized as the data of the next address. In this mode, 6-bit, 16-bit, or 22-bit serial command data are stored to the respective registers immediately when those data are fetched. Address and data should be sent LSB first, in the same way as standard write mode. If the data bit does not contain either 6-bits, 16-bits, or 22-bits at the end of the data stream, any empty data bits are ignored.

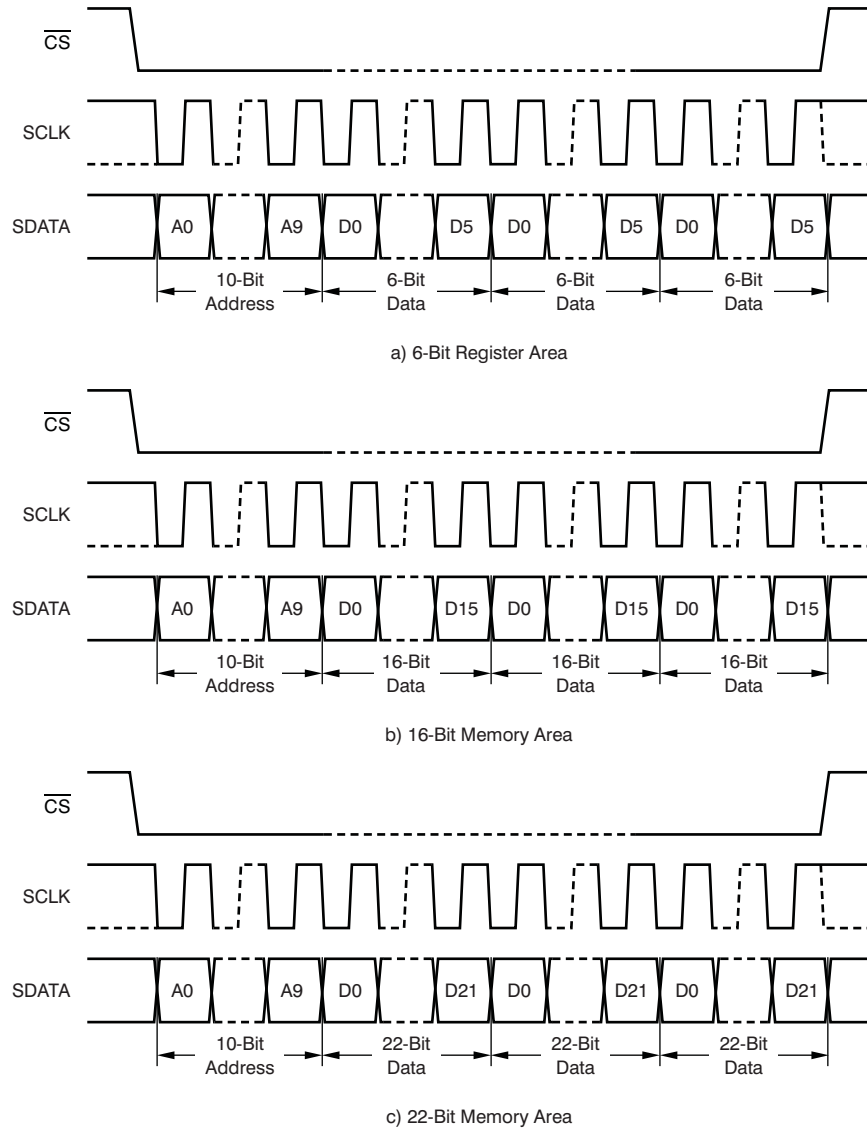

Figure 14. SPI Continuous Write Mode

### Mode Confusion

If 22 bits of data are sent to a 6-bit register area, the SPI recognizes *continuous write mode*, because usually only 6-bit data should be sent to 6-bit register area in *standard write mode*, as shown in Figure 15. The end-of-data point is recognized by the rising edge of CS.

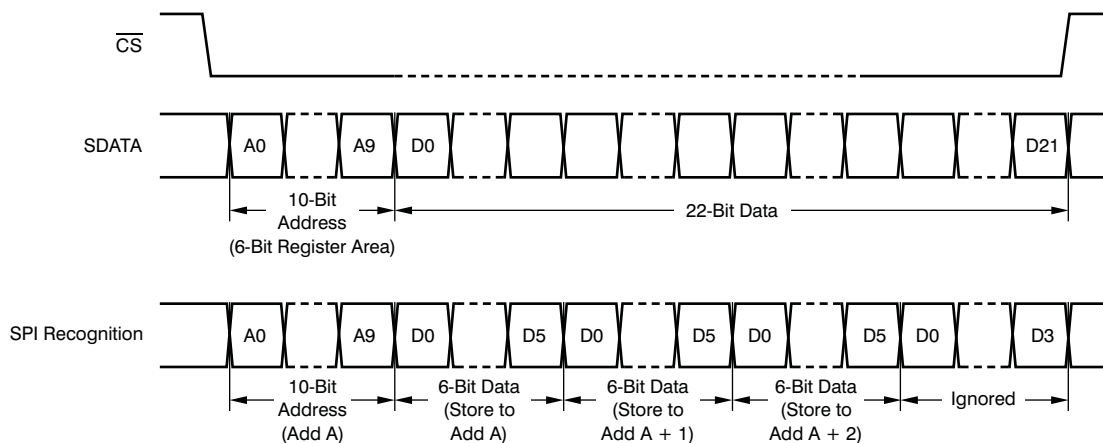

Figure 15. Mode Confusion

SPI recognition is shown in Table 9.

Table 9. SPI Recognition

ADDRESS AREA	DATA WIDTH			
	6-BIT	16-BIT	22-BIT	32-BIT
6-bit register	Standard <sup>(1)</sup> (one word)	Continuous <sup>(2)</sup> (two words)	Continuous (three words)	Continuous (five words)
16-bit memory	Ignored	Standard (one word)	Standard <sup>(3)</sup> (one word)	Continuous (two words)
22-bit memory	Ignored	Ignored	Standard (one word)	Standard (one word)

- (1) Shaded cells indicate standard operation.
- (2) Continuous = continuous write mode.
- (3) Standard = standard write mode.

### Read and Write Batting

Address 100h-3FFh is the memory area. HA, VA, and HS access this memory area to read programs. If the SPI writes to the memory area during a program read, the programmed operation is cancelled. SPI operation should be done with *TG disable*. If SPI operation must be done with *TG enable* (TG operating), the SPI must write for a no-read term (no toggling term). For the register area (000h-0FFh), this precaution is not necessary.

### REGISTER UPDATE

The update timing of each register is specified in Table 10.

Table 10. Updated Timing

REGISTER ADDRESS	UPDATE TIMING
000h	Real time
001h-01Fh	Timing specified at bits 0-2 of 000h (AFE update)
020h-035h	Real time
036h[2:0]	VD; refer to the <i>CCD Timing Composition</i> section of the <i>TG (Timing Generator) Section</i> for details.
036h[5:3]	TRIG; refer to the <i>CCD Timing Composition</i> section of the <i>TG (Timing Generator) Section</i> for details.
037h-0FFh	Timing specified at bit 3 of 000h (TG update)

The AFE register is updated in real time by the R<sub>LOAD</sub> pin or VD, as shown in [Table 11](#).

**Table 11. Update Select Register (AFE)**

PARAMETER	REGISTER ADDRESS	DESCRIPTION
AFE UPDATE	000h[0]	0 = Real-time update (default) 1 = Updated by R <sub>LOAD</sub> pin or VD
AFE UP POL	000h[2:1]	AFE register update signal and polarity 00b = R <sub>LOAD</sub> rising edge (default) 10b = VD rising edge 01b = R <sub>LOAD</sub> falling edge 11b = VD falling edge

The TG register can be updated at a specified line number through VA instruction. The update method selection is described in [Table 12](#). In general, this function is used for SUBN control.

**Table 12. Update Select Register (TG)**

PARAMETER	REGISTER ADDRESS	DESCRIPTION
TG UPDATE	000h[3]	0 = Real-time update (default) 1 = Updated by VA instruction line number Refer to the <a href="#">Vertical Sequence</a> section for VA instruction details.

### MCK STOP DETECT

The MCK stop detect function is supported, as shown in [Table 13](#). If an MCK stop was detected, all register values are cleared. After an MCK stop detect, a SYSRST is required.

**Table 13. MCK Stop Detect Register**

PARAMETER	REGISTER ADDRESS	DESCRIPTION
MCK detect	020h[4]	0 = Disabled 1 = Enabled (default)

### STANDBY FUNCTION

For increased power savings, this device can be put into a standby mode (power-down mode) through serial interface control when the device is not in use. In this mode, all function blocks are disabled. Current consumption drops to about 2 mA. Because all the bypass capacitors discharge during this mode, a substantial time (usually on the order of 200 ms to 300 ms) is required to return from standby mode. A four-part standby is selected independently, as described in [Table 14](#).

**Table 14. Standby Control Register**

SECTION	REGISTER ADDRESS	DESCRIPTION	SIGNAL STATUS IN STANDBY
TG	020h[0]	0 = Standby (default) 1 = Normal operation	Refer to the <a href="#">Signal</a> section of the <a href="#">TG (Timing Generator) Section</a> .
AFE	001h[0]	0 = Normal operation (default) 1 = Standby	Digital output = high impedance
DAC1	001h[1]	0 = Enabled 1 = Disabled (Standby) (default)	Analog output = low
DAC2	001h[2]	0 = Enabled 1 = Disabled (Standby) (default)	—

AFE standby, DAC1 standby, or DAC2 standby should be completed before TG standby if using the VD update method for the the AFE section. If the AFE standby is completed after TG standby, the AFE standby, DAC1 standby, or DAC2 standby are not activated.

## SYSTEM RESET

All parameters are reset to the respective default values when the SYSRST pin goes low asynchronously with respect to the system clock. All register and memory values are cleared by SYSRST. SYSRST should be pulled up for operation. Figure 16 shows typical SYSRST implementation with a pull-up resistor.

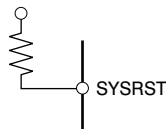

Figure 16. SYSRST Pin

## POWER-UP SEQUENCE

When the device is powered up, follow this recommended sequence:

1. Turn on the power supplies for the device.
2. Apply the master clock input to the MCK, VD, and HD signals.
3. Input the serial data for the 6-bit register setting. Input SRG for 16-bit serial data. (10-bit address + 6-bit data). TG disable must be complete. (020h[0] = 0)
4. Input the serial data for  $V_{HIGH\ SPEED}$  transfer toggling. Input SRG for 26-bit serial data. (10-bit address + 16-bit data)
5. Input the serial data for  $V_{RATE}$  toggling. Input SRG for 32-bit serial data. (10-bit address + 22-bit data)
6. Input the serial data for  $H_{RATE}$  toggling. Input SRG for 32-bit serial data. (10-bit address + 22-bit data)
7. Input the serial data for TG enable. Input SRG for 16-bit serial data. (10-bit address + 16-bit data) TG enable must be complete. (020h[0] = 1)

Figure 17 shows the timing for the power-up sequence.

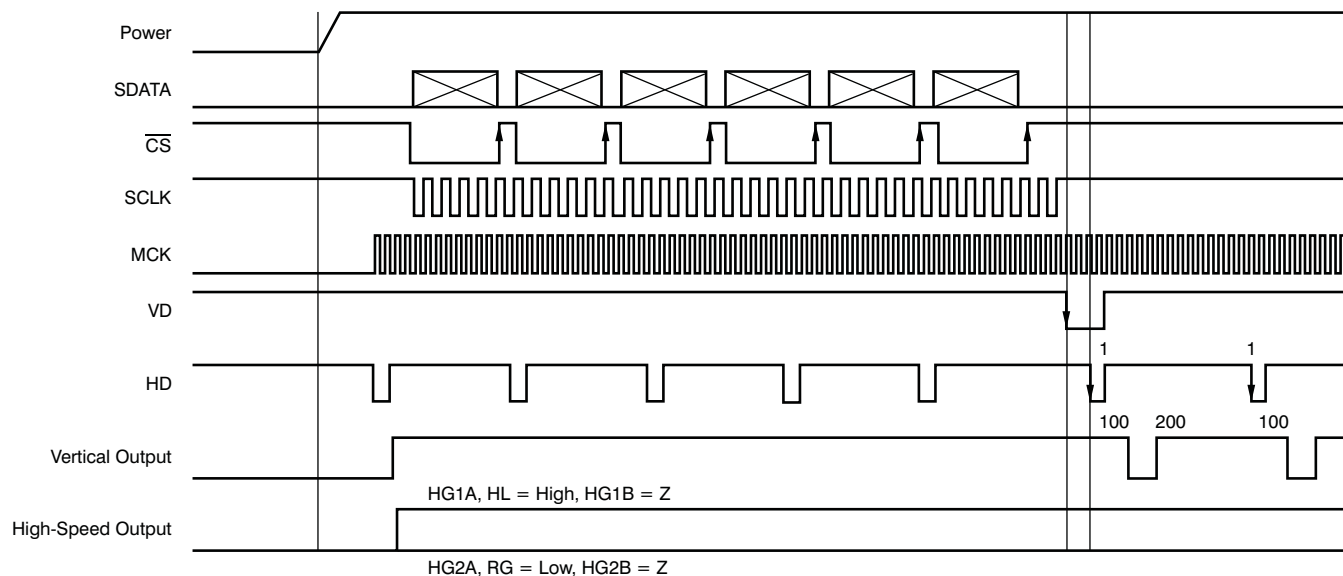

Figure 17. Power-Up Sequence

## AFE (ANALOG FRONT-END) SECTION

### OVERVIEW

#### Composition

The VSP01M01/VSP01M02 are complete mixed-signal ICs that contain all of the key features associated with processing of the CCD imager output signal in video cameras, digital still cameras, security cameras, or similar applications. A simplified block diagram of the AFE section is shown in [Figure 18](#). The AFE section includes these features:

- Correlated double sampler (CDS)
- Programmable gain amplifier (PGA)
- Analog-to-digital converter (ADC)
- Input clamp
- Optical black (OB) level clamp loop
- Timing control
- Internal reference voltage generator

It is recommended that an off-chip emitter follower buffer be placed between the CCD output and the device CCDIN input. The serial interface controls PGA gain, clock polarity setting, and operation mode.

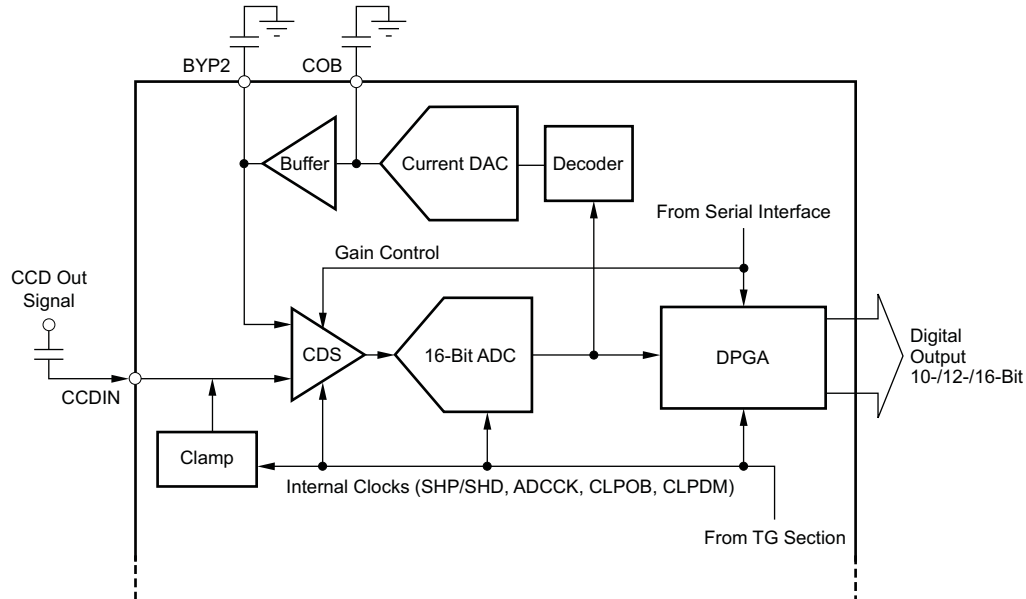

Figure 18. Simplified Block Diagram of the AFE Section

#### Function

[Table 15](#) shows the major functions of the AFE section.

Table 15. AFE Functional Summary

FUNCTION	RELATED REGISTER	SECTION
Selectable CDS (analog) gain	008h	Programmable Gain
Programmable digital gain	006h, 007h	
Programmable OB clamp level	004h	OB Loop and OB Clamp Level
Standby mode	001h[2:0]	Standby Function
Hot pixel rejection	005h	Hot Pixel Rejection
Selectable register update	000h[2:0]	AFE Register Update Function
Data output enable control	002h[2]	Data Output Enable



## CORRELATED DOUBLE SAMPLER (CDS)

The output signal of the CCD image sensor is sampled twice during one pixel period: once at the reference interval and again at the data interval. Subtracting these two samples extracts the video information of the pixel as well as removes any noise, which is common to both intervals. Thus, CDS is very important to reduce the reset noise and the low-frequency noise that are present on the CCD output signal. Figure 19 shows the block diagram of the CDS section. SHP, SHD, CLPDM, and CLPOB are supplied from the TG section; these signals are active low (close).

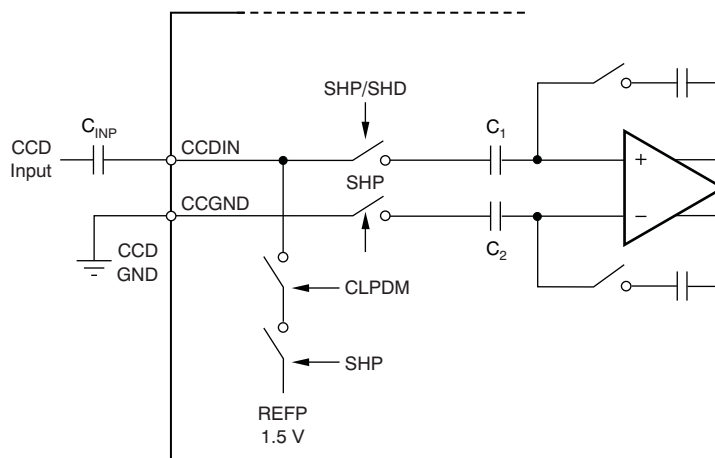

Figure 19. Block Diagram of CDS and Input Clamp

## INPUT CLAMP

The buffered CCD output is capacitively coupled to this device. The purpose of the input clamp is to restore the dc component of the input signal, which was lost with the ac coupling, and to establish the desired dc bias point for the CDS. Figure 19 also shows the block diagram of the input clamp. The input level is clamped to the internal reference voltage, CM (1.25 V), during the dummy pixel interval. More specifically, the clamping function becomes active when both CLPDM and SHP are active.

Immediately after power on, the clamp voltage of the input capacitor is not charged. For fast charge-up for clamp voltage, these devices provide a boost-up circuit.

## ANALOG-TO-DIGITAL CONVERTER (ADC)

These devices provide a high-speed, 16-bit analog-to-digital converter (ADC). This ADC uses a fully differential pipelined architecture with a correction feature. The ADC error correction architecture is very advantageous to realize a better linearity for lower signal levels. Large linearity errors tend to occur at specific points in the full-scale range and the linearity improves for a signal level below that specific point. The ADC ensures 16-bit resolution across the entire full-scale range.

## OB LOOP AND OB CLAMP LEVEL

This device has a built-in OB offset self-calibration circuit (OB loop) that compensates the OB level by using optical black (OB) pixels output from the CCD image sensor. A block diagram of the OB loop and OB clamp circuit is shown in Figure 20.

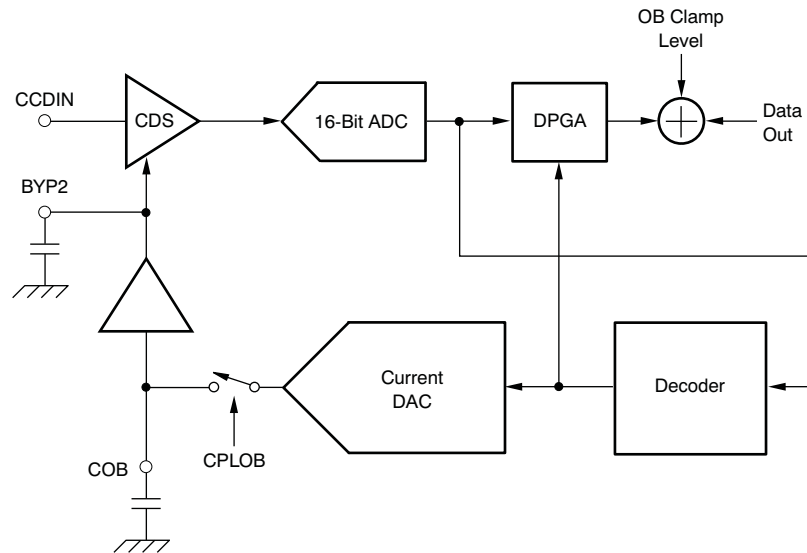

Figure 20. OB Loop and OB Clamp Level

CCD offset is compensated by the convergence of this calibration circuit while activating CLPOB during a period when OB pixels are output from the CCD. Note that the total number of effective pixels is (the CLPOB period – 6 pixels).

At the CDS circuit, CCD offset is compensated as a difference between reference level and data level of the OB pixel. These compensated signal levels are recognized as actual *OB levels*, and the outputs are clamped to the OB levels set by the serial interface. These OB levels are the base of black for the effective pixel period thereafter.

Because DPGA, which is a gain stage, is outside the OB loop, OB levels are not affected even if the gain is changed.

Converging time of the OB loop is determined by the capacitor value connected to the COB terminal and output from the current output DAC of the loop. The time constant can be obtained from Equation 1:

$$T = \frac{C}{(16384 \times I_{\text{MIN}})} \quad (1)$$

Where:

C is the capacitor value connected to COB,

$I_{\text{MIN}}$  is the minimum current (0.15  $\mu\text{A}$ ) of the current DAC which is an equivalent current to 1 LSB of the DAC output.

When  $C = 0.1 \mu\text{F}$ , T is 40.8  $\mu\text{s}$ .

Slew rate (SR) can be obtained from Equation 2:

$$\text{SR} = \frac{I_{\text{MAX}}}{C} \quad (2)$$

Where:

C is the capacitor value connected to COB,

$I_{\text{MAX}}$  is the maximum current (76  $\mu\text{A}$ ) of the current DAC which is an equivalent current to 511 LSB of the DAC output.

Immediately after power-on, the COB capacitors are not charged. For fast start-up, a COB voltage boost-up circuit is provided.

The OB clamp level (digital output value) can be set externally through the serial interface by inputting a digital code to the OB clamp level register. The digital codes to be input and the corresponding OB clamp levels are shown in [Table 16](#).

**Table 16. Input Code and OB Clamp Level to Be Set**

CODE (Register = 004h)	CLAMP LEVEL (LSB)	
	VSP01M01 (10-Bit)	VSP01M02 (12-Bit)
00000b	16	64
00001b	18	72
—	—	—
00110b	28	112
00111b	30	120
01000b (default)	32	128
01001b	34	136
—	—	—
11110b	76	304
11111b	78	312

## PROGRAMMABLE GAIN

The VSP01M01 and VSP01M02 gain ranges from  $-9$  dB to 44 dB. The desired gain is set as a combination of CDS gain and the digital programmable gain amplifier (DPGA). CDS gain can be programmed in the range of  $-3$  dB to 18 dB ( $-3$  dB, 0 dB, 6 dB, 12 dB, 18 dB).  $-3$  dB gain supports large input levels ranging from 1 V to 1.3 V. Digital gain can be programmed in the range of  $-6$  dB to 26 dB in 0.03125-dB steps. Both gains are controlled through the serial interface. Gain changes linearly in proportion to the setting code, as shown in [Figure 21](#).

**Table 17. Programmable Gain Register<sup>(1)</sup>**

PARAMETER	REGISTER ADDRESS
CDS (analog) gain	008h
DPGA	006h, 007h

(1) Refer to the [Configuration Register](#) section for details.

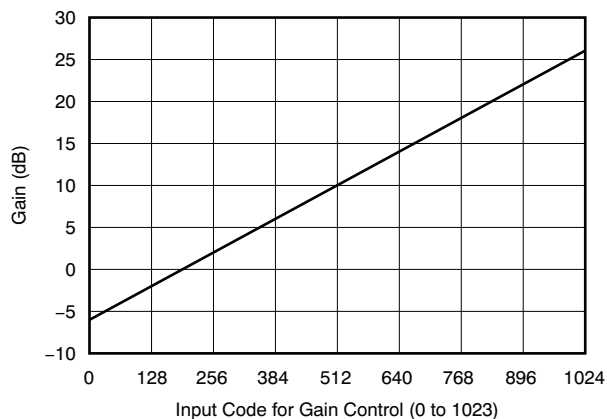

**Figure 21. DPGA Setting Code vs Gain**

## PRE-BLANKING AND DATA LATENCY

These devices have a pre-blanking function. When PBLK = low, all digital outputs are set to '0' after the latching ADCCK clocks counting from PBLK go low to accommodate the clock latency of these devices.

## CLOCK TIMINGS FOR THE AFE SECTION

The CDS and the ADC are operated by SHP and SHD; the derivative timing clocks are generated by the on-chip timing generator. The output register and decoder are operated by ADCCK. The digital output data are synchronized with ADCCK. The timing relationship between the CCD signal, SHP, SHD, ADCCK, and the output data is described in the [Timing Characteristics](#). CLPOB is used to activate the black level clamp loop during the OB pixel interval and CLPDM is used to activate the input clamping during the dummy pixel interval. In standby mode, ADCCK, SHP, SHD, CLPOB, and CLPDM are internally masked and pulled high. Refer to the [Standby Function](#) section of the [Common Section](#) and the [Signal](#) section of the [TG \(Timing Generator\) Section](#) for details.

## VOLTAGE REFERENCE

All reference voltages and bias currents used on the device are created from an internal band-gap circuitry. The VSP01M01 and VSP01M02 have symmetrically independent voltage references.

CDS and the ADC primarily use three reference voltages: REFP (1.5 V), REFN (1.0 V), and CM (1.25 V) of the individual reference. REFP and REFN are buffered on-chip. CM is derived as the mid-voltage of the register chain connecting REFP and REFN internally. Twice the difference voltage between REFP and REFN [that is, 2(REFP – REFN)] determines the ADC full-scale range.

REFP, REFN, and CM should be heavily decoupled with appropriate capacitors. Refer to the [Terminal Functions](#) section for details.

## HOT PIXEL REJECTION

Sometimes the OB pixel output signal from the CCD includes an unusual level signal that causes pixel defection. If this level reaches a full-scale level, it may affect OB level stability. These devices have a function that rejects this large unusual pixel level (hot pixel) at the OB pixel. Through this function, these devices improve the CCD yield at camera manufacturing.

The rejection level for hot pixels can be programmed through the serial interface. When a hot pixel comes from the CCD, the VSP01M01 and VSP01M02 omit it and replace it with the previous pixel level from the OB level calculation.

**Table 18. Hot Pixel Rejection Register<sup>(1)</sup>**

PARAMETER	REGISTER ADDRESS
Hot pixel rejection	005h

(1) Refer to the [Configuration Register](#) section for details.

## AFE REGISTER UPDATE FUNCTION

Some registers for the AFE section can be selected during update timing. Refer to the [Register Update](#) section of the [Common Section](#) for details.

## DATA OUTPUT ENABLE

Data out is enabled or disabled by the Data Output Enable register, as shown in [Table 19](#). When disabled, the output level is high impedance.

**Table 19. Data Output Enable Register**

PARAMETER	REGISTER ADDRESS	DESCRIPTION
OE	002h[2]	0 = Enabled (default) 1 = Disabled (high impedance)

## DAC

The VSP01M01 and VSP01M02 provide a two-channel, general-purpose, 8-bit DAC, as shown in [Table 20](#). This DAC can be used for various applications such as CCD bias control, iris control, etc.

**Table 20. DAC Input Register<sup>(1)</sup>**

PARAMETER	REGISTER ADDRESS
DAC1	00Ah, 00Bh
DAC2	00Ch, 00Dh

(1) Refer to the [Configuration Register](#) section for details.

## TG (TIMING GENERATOR) SECTION

### OVERVIEW

#### Composition

The VSP01M01 and VSP01M02 support variable CCD timing. For horizontal and vertical sequencing, full programming is available. These devices include a counter, high-speed signal generator, VA selector for frame mode change, output controller, and a TRIG function section.

High-speed signal rise and fall timing are generated through the high-speed signal generator.

For each signal, enabling and initial polarity are controlled by the output controller.

#### Counter

Table 21 shows the operation of each counter.

**Table 21. Counter Operation**

COUNTER	INCREASED BY	RESET BY	OUTPUT/OPERATION
Frame	Reset (VA)	VA instruction TRIG	Frame count
VA (vertical)	Reset (HA)	VD EOF (VA) TRIG	Line count Instruction:  Call HA Address  Frame count reset Initialize Event number start/stop EOF
HA (horizontal)	MCK	HD EOL (HA) TRIG	Pixel count Signal toggling V0N-12N, P0-5, CLPDM, CLPOB, PBLK, HBLK, HDIV, HD, VD  Instruction: HS number start/stop EOL
HS (V <sub>HIGH SPEED</sub> transfer)	MCK	HS number start (HA) Repeat (HS)	V <sub>SIGNAL</sub> toggling Repeat instruction
Event	Trigger V	Event number start (VA)	V <sub>SIGNAL</sub> control

The HA counter controls the horizontal sequence with the pixel counter. Some signal toggling is controlled by the pixel step. The VA counter controls the vertical sequence with the line counter. The VA calls the HA address by a line step. HS controls the V<sub>HIGH SPEED</sub> transfer sequence with a pixel counter. V<sub>SIGNAL</sub> toggling is controlled by a pixel step. This counter is started by the HA start command. The loop cycle continues until an HA stop command is issued. An event counter controls V<sub>HIGH-SPEED</sub> transfer for an electrical zoom function. This counter operates between the VA start and stop commands.

#### TRIG Function Section

TRIG has the following functionality:

- Frame counter reset function
- Load frame function
- TG stop function

These functions are activated by a register setting.

## CCD Support

The VSP01M01 and VSP01M02 TG are designed for various kinds of CCD sensor operation, including IT-CCD as well as FT-CCD, IT progressive CCD, FIT-CCD, and motion CCD, as shown in [Figure 22](#).

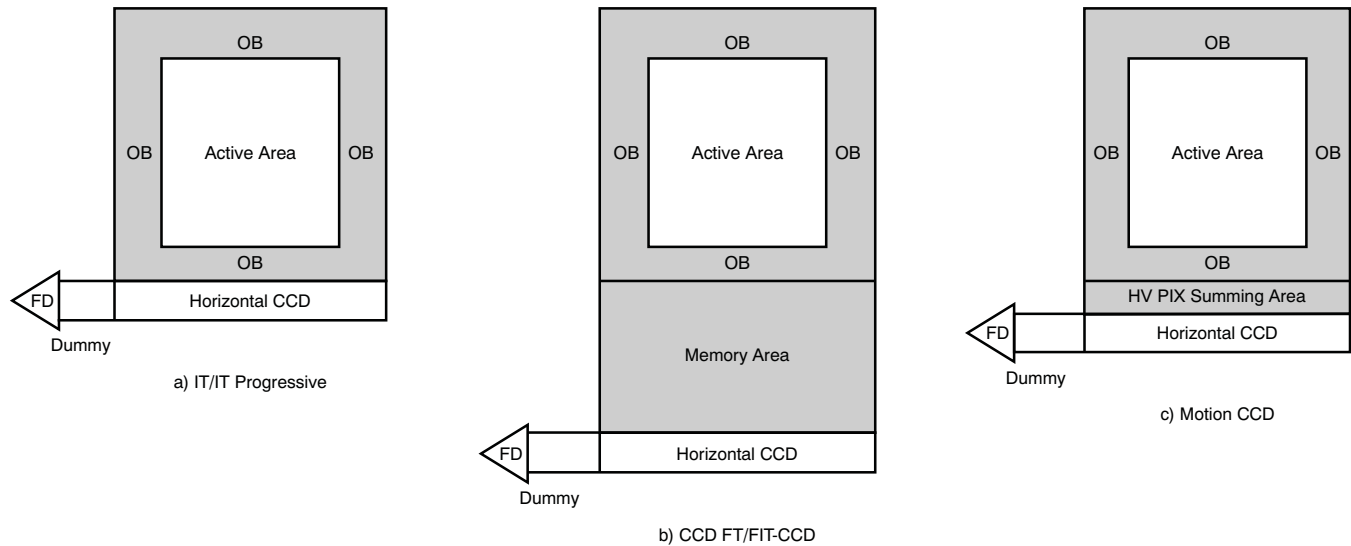

NOTE: Shaded cells indicate the area under discussion.

**Figure 22. CCD Support Applications**

The CCD operation supports these functions:

- Vertical format:
  - IT-CCD: two, three, or four field types
  - IT-progressive CCD
  - FT-CCD
  - FIT-CCD
  - Motion CCD
- Horizontal transfer format:
  - Four channels, two phases
- Floating diffusion reset:
  - One floating diffusion or single phase reset

### Timing Range

The VSP01M01 and VSP01M02 have a horizontal 13-bit counter and a vertical 12-bit counter. The counter synchronizes the pixel rate master clock (MCK). The reference signal (HD/VD) has flexibility that can select either the master or slave mode. The timing is programmable so that the TG generates every signal. Apply the program through the serial interface. Refer to the [Register/Memory Map](#) section of the [Common Section](#) for details.

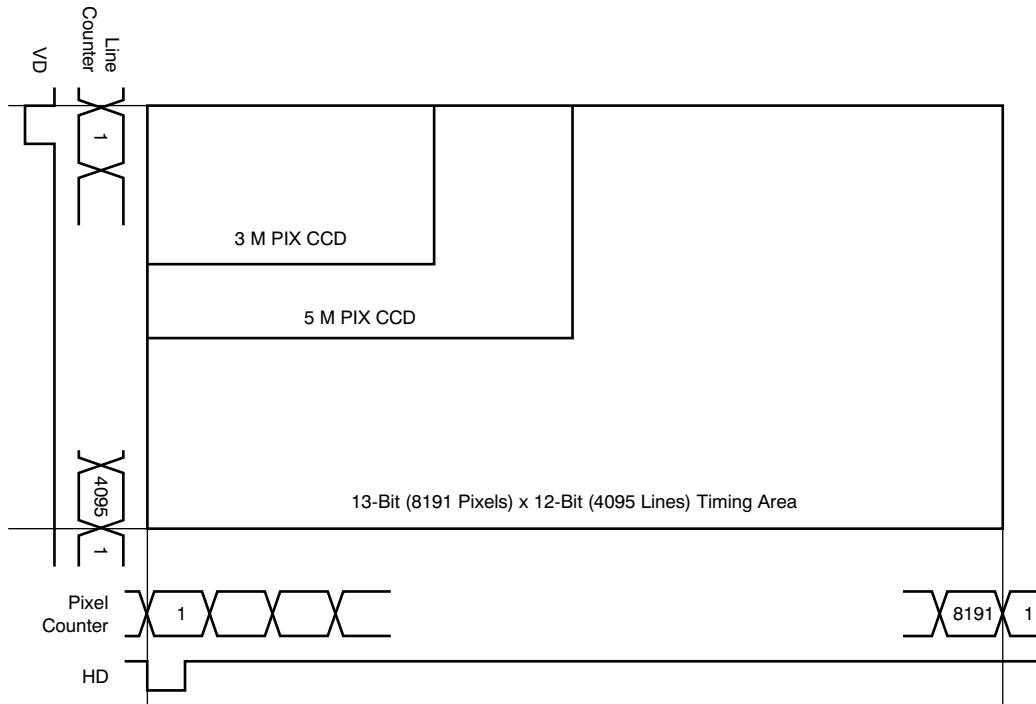

Figure 23. TG Handling Time Range

### Operating Mode

The primary operating mode consists of a combination of normal mode, monitor mode, still mode, and motion picture mode.



### Normal Mode

Normal mode operates as a basic function with an electric shutter, integration, readout, vertical transfer, and horizontal transfer.

IT-CCD, FT-CCD, and progressive-CCD use a horizontal sequence (see the [Horizontal Sequence](#) section), vertical sequence (see the [Vertical Sequence](#) section), and an HBLK function (see the [HBLK Function](#) section). IT-CCD, progressive-CCD, and most of the FT-CCD use an electric shutter function (see the [Electric Shutter Function](#) section).

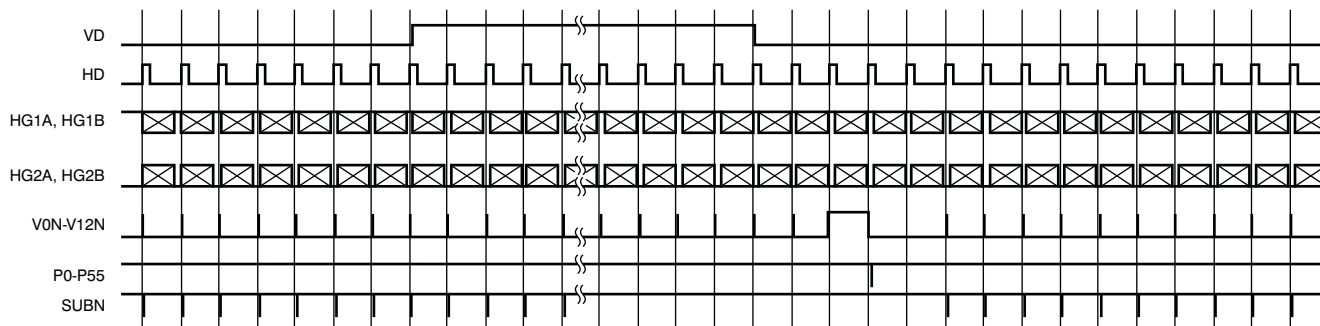

Figure 24. Normal Mode Timing Example

### Monitor Mode

Monitor mode operates vertically over several pixel intervals, with an electric shutter, integration, readout, vertical transfer, and horizontal transfer.

IT-CCD, FT-CCD, and progressive-CCD use a horizontal sequence (see the [Horizontal Sequence](#) section), vertical sequence (see the [Vertical Sequence](#) section), and an HBLK function (see the [HBLK Function](#) section). IT-CCD, progressive-CCD, and most of the FT-CCD use an electric shutter function (see the [Electric Shutter Function](#) section).

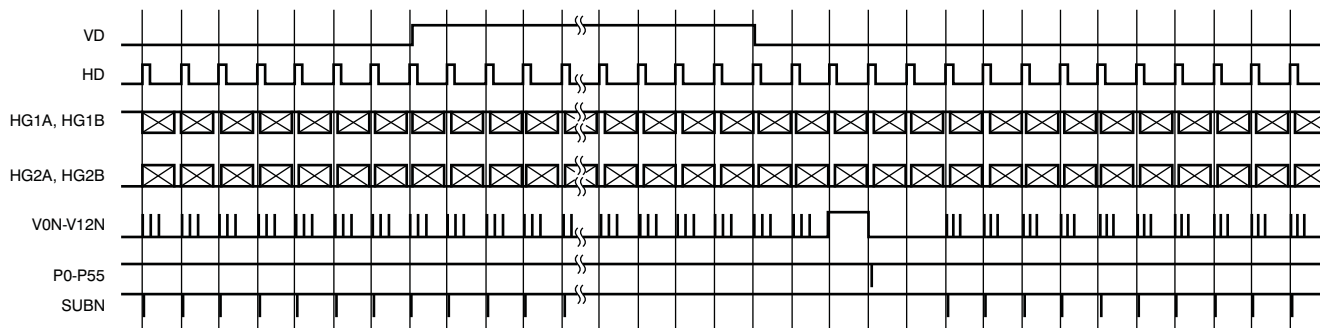
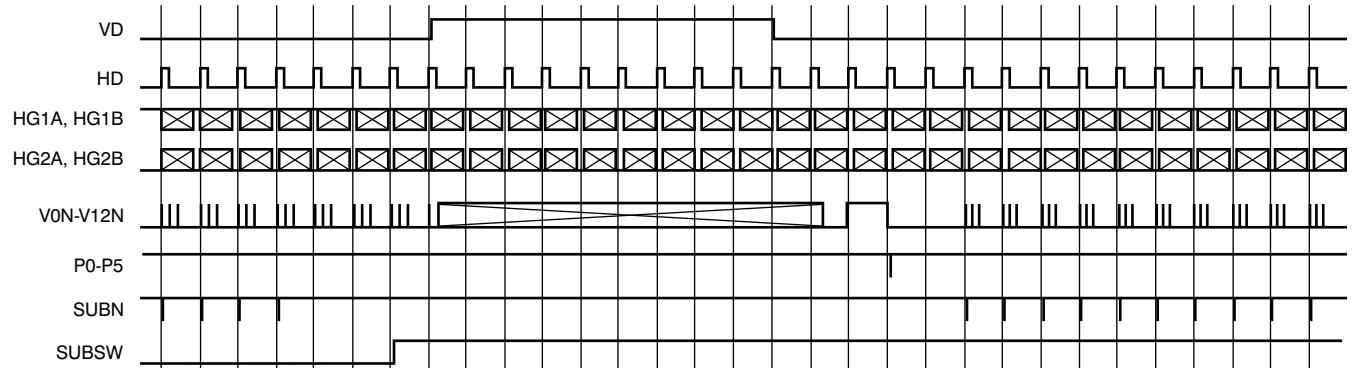

Figure 25. Monitor Mode Timing Example

**Still Mode**

Still mode operates as a smear dump operation and SUBSW control.

IT-CCD, FT-CCD, and progressive-CCD use a vertical sequence (see the [Vertical Sequence](#) section), horizontal sequence (see the [Horizontal Sequence](#) section), vertical high-speed transfer sequence (see the [Vertical High-Speed Transfer \(HS\) Sequence](#) section), and an HBLK function (see the [HBLK Function](#) section). IT-CCD, progressive-CCD, and most of the FT-CCD uses an electric shutter function (see the [Electric Shutter Function](#) section). IT-CCD and progressive-CCD use a SUBSW function (see the [SUBSW Function](#) section) for CCD substrate bias control.

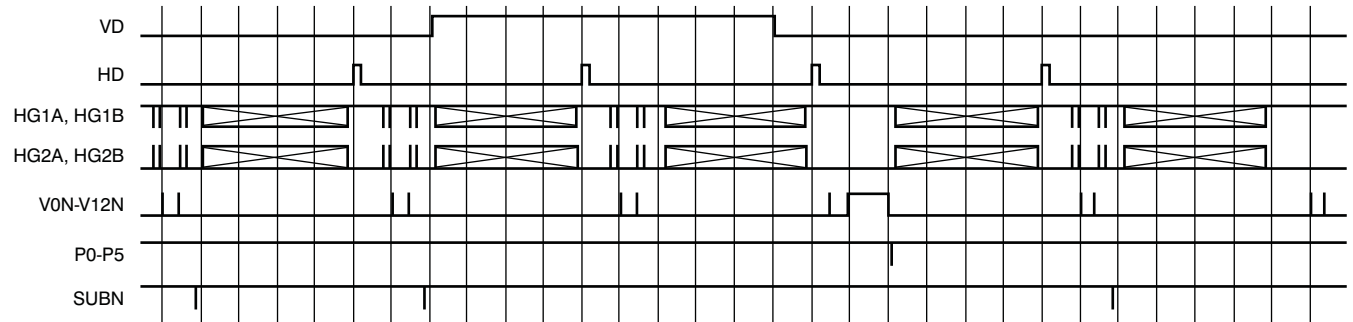

**Figure 26. Still Mode Timing Example**

**Motion Picture Mode**

Motion picture mode adds up the pixels in the CCD horizontal and vertical transfer.

IT-CCD is dedicated to this mode and uses a vertical sequence (see the [Vertical Sequence](#) section), horizontal sequence (see the [Horizontal Sequence](#) section), an HBLK function (see the [HBLK Function](#) section), and HDIV function (see the [HDIV Function](#) section).



**Figure 27. Motion Picture Mode Timing Example**

**Function**

Table 22 summarizes the primary TG section functionality.

**Table 22. TG Function**

FUNCTION	RELATED REGISTER	SECTION
Adjustable high-speed pulse	002h, 003h, 010h-01Ah	<a href="#">High-Speed Pulse Adjustment</a>
Programmable horizontal pattern	200h-3FFh	<a href="#">Horizontal Sequence</a>
Programmable vertical pattern	180h-1FFh	<a href="#">Vertical Sequence</a>
Programmable $V_{CCD}$ high-speed transfer pattern	100h-17Fh	<a href="#">Vertical High-Speed (HS) Transfer Sequence</a>
Electrical zoom function	030h-033h, 037h-03Eh	
Sync signal selectable (master or slave)	020h	<a href="#">Synchronous Function</a>
Field index for two-field CCD	022h, 02Fh, 035h[0]	
Programmable electrical shutter	08Ch-0A3h	<a href="#">Electric Shutter Function</a>
Programmable strobe	04Ch-07Bh	<a href="#">Strobe Function</a>
Programmable MECH shutter	040h-04Bh	<a href="#">MSHUT Function</a>
Programmable SUBSW	07Ch-08Bh	<a href="#">SUBSW Function</a>
Programmable frame sequence for strobe, MECH shutter, and SUBSW	021h[4], 022h[2]	<a href="#">Frame Count Function</a>
Frame mode control by trigger	021h[3:2], 036h[5:3]	<a href="#">Trigger Function</a>
Waiting mode by trigger	020h[4], 021h[1:0]	
Frame sequence (for strobe, MECH shutter, and SUBSW) control by trigger	021h[4:3], 022h[2]	
Standby mode	020h[0]	<a href="#">Standby Function</a>
Programmable HG signal for horizontal blank	—	<a href="#">HBLK Function</a>
Flexible pixel summing operation	01Bh[2:0]	<a href="#">HDIV Function</a>
Monitor out for internal signal	001h[3], 0B5h	<a href="#">Signal</a>
Selectable HG power	01Ch[1:0]	
Flexible register update	000h[3]	<a href="#">TG Register Update Function</a>

## SIGNAL

This device has 32 vertical signals and nine horizontal signals. The universal-purpose signal has flexible usage. Refer to the [Terminal Functions](#) table for details.

Pin enabling of vertical signals is set by register address 023h-028h. Pin initial polarity is set by register address 029h-02Eh. The initial polarity is applied by the VA *initialize* instruction. (The initial polarity is not applied by the TG operation start). Refer to the [Configuration Register](#) section for details.

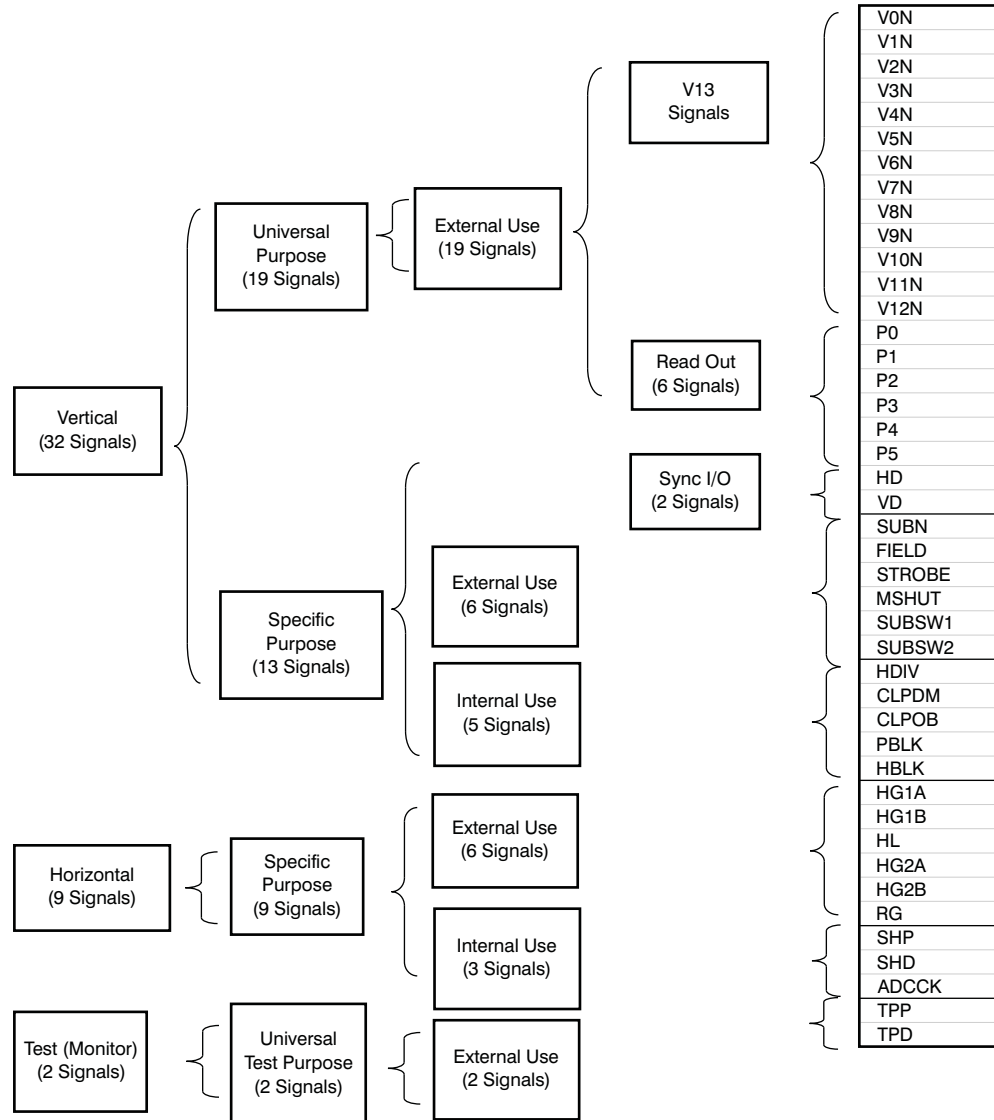

Figure 28. Signal Overview

### Programmed Signal (Memory Assignment)

The signal timing (described in [Table 23](#)) is specified by the HA (horizontal address) program. Terminal assignment numbers are used by the HA command (data[17:13]). The default output level is fixed except for an MCK stop condition. These signals are disabled with a power-up default. The CLPDM, CLPOB, PBLK, HBLK, and HDIV signal active polarity is low.

**Table 23. Memory Assignment Signal**

TERMINAL NAME	SIGNAL FUNCTION	TERMINAL ASSIGNMENT	REGISTER ADDRESS		LEVEL			
			ENABLE	INITIAL	POWER-UP DEFAULT	AFE STANDBY	TG STANDBY	TRIG STOP MCK
V[0:12]N	Vertical transfer signal (high-speed transfer)	00001b-01101b (1-13)	023h-025h	029h-02Bh	High		High	
P[0:5]	Vertical transfer signal (general signal)	10000b-10101b (16-21)	025h-026h	02Bh-02Ch				
CLPDM	Clump dummy signal	11000b (24)	026h[5]	02Ch[5]	Low	No effect	Low	No effect
CLPOB	Clump OB signal	11001b (25)	[0]	[0]				
PBLK	Pre-blanking signal (digital out = low)	11010b (26)	[1]	[1]				
HBLK	Horizontal transfer pulse blank	11011b (27)	[2]	[2]				
HDIV	Horizontal transfer pulse divide	11100b (28)	[3]	[3]				
VD	Vertical sync signal (master mode)	11101b (29)	[4]	[4]				
HD	Horizontal sync signal (master mode)	11110b (30)	[5]	[5]				

### Decoded Signal (Register Assignment)

The signal timing of [Table 24](#) is specified by the decoder. The decoder refers to the register value of the frame number, line number, or pixel number. Default output levels are fixed except for an MCK stop condition. These signals are disabled with a power-up default.

**Table 24. Register Assignment Signal**

TERMINAL NAME	SIGNAL FUNCTION	REGISTER ADDRESS		LEVEL				
		ENABLE	INITIAL	POWER-UP DEFAULT	AFE STANDBY	TG STANDBY	TRIG STOP MCK	
SUBN	Electric shutter	028h	[0]	[0]	High		High	No effect
FIELD	Field index		[1]	[1]				
STROBE	Strobe signal		[2]	[2]	Low	No effect	Low	
MSHUT	Mechanical shutter		[3]	[3]				
SUBSW1	CCD substrate bias control 1		[4]	[4]				
SUBSW2	CCD substrate bias control 2		[5]	[5]				

**Phase Controlled Signal (Register Assignment)**

The high-speed signal timing is specified by a register. Default output levels are shown in [Table 25](#).

**Table 25. Horizontal Signal**

TERMINAL NAME	SIGNAL FUNCTION	REGISTER ADDRESS		LEVEL				
		ENABLE		POWER-UP DEFAULT	DISABLE 01Bh[2]	ENABLE		
		01Bh[3]				01Ch[2]	AFE STANDBY	TG STANDBY
HG1A, HL	Horizontal transfer signal 1	—		High	01Bh[4] 0 = Low 1 = High	High	High	High
HG1B		01Ch[2]		Z				
HG2A	Horizontal transfer signal 2	—		Low	Low	Low	Low	Low
HG2B		01Ch[2]		Z				
RG	CCD reset signal	Always enable		Toggling	No effect	Low	Toggling	Toggling
SHP	Reference level sampling					High		
SHD	Data level sampling					High		
ADCCK	ADCCK buffer					Low		

**HG Drive**

The HG drive power for HG1A, HG1B, HG2A, and HG2B is selected by the HG power select register (01Ch[1:0]), as shown in [Table 26](#).

**Table 26. HG Power Select Register**

TERMINAL NAME	REGISTER 01Ch[1:0]
HG1A	00 = Minimum
HG1B	01 = Default
HG2A	10 = Mid-range
HG2B	11 = Maximum

The HG drive power can be doubled by a connection between HGAx and HGBx. However, this setting is typically used for power dissipation. If HGBx is not used, disable and do not connect HGBx.

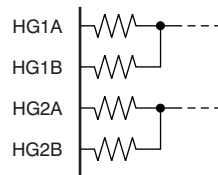

**Figure 29. HG Double Power Connection**

## Monitor Signal

The test pin (TPP, TPD) is set up by address 001h, data bit [3] = 1, as shown in [Table 27](#). [Table 28](#) describes TPP and TPD.

**Table 27. Monitor Pin Enable Register<sup>(1)</sup>**

PARAMETER	REGISTER ADDRESS	VALUE
Monitor pin	001h[3]	1 = Enable

(1) Refer to the [Configuration Register](#) section for details.

**Table 28. Test Pin Output Select**

REGISTER 0B5h[3:0]	TPP	TPD
1000b (8)	SHP	SHD
1001b (9)	CLPOB	CLPDM
1010b (10)	PBLK	HDIV
1011b (11)	HBLK	—

SHP and SHD are monitored at the TG section output, as shown in [Figure 30](#). The actual sampling point is delayed from the monitor point. The delay time is shown in [Figure 30](#). The actual sampling point delay = delay controller value (003h[1:0] = 0 ns-6 ns) + sampling delay (3 ns).

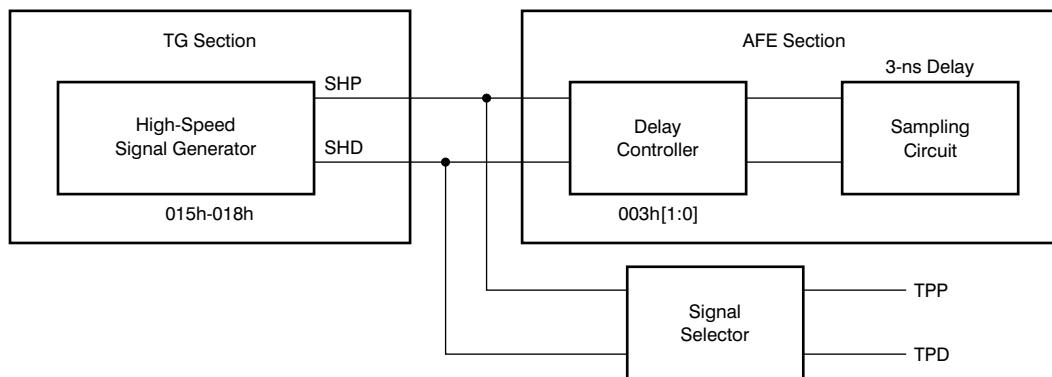

**Figure 30. SHP/SHD Monitor Out**

## HIGH-SPEED PULSE ADJUSTMENT

The high-speed pulse can be adjusted in steps of one pixel clock cycle per 100. The assignment register for each pulse is shown in [Table 29](#). The rising edge of the RG pulse as a reference.

**Table 29. High-Speed Pulse Adjustment Register**

CONTROL ITEM	TERMINAL NAME	REGISTER ADDRESS		
		FALLING	RISING	DELAY
RG	RG	014h[4:0]	—	—
G1h	G1Ah G1Bh HL	011h[4:0]	010h[4:0]	
	G2h	G2Ah G2Bh	012h[4:0]	
SHP	SHP	015h[4:0]	016h[4:0]	
SHD	SHD	017h[4:0]	018h[4:0]	003h[1:0]
ADCK	ADCK	—	—	019h[5:0] 019h[6]
Data out	B0-B15	—	—	002h[1:0]

**RG Control**

RG control is described in [Figure 31](#) and [Table 30](#).

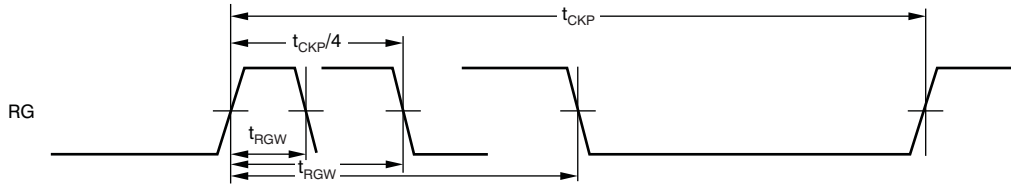

**Figure 31. RG Fall Timing**

**Table 30. RG Fall Register**

ADDRESS	NAME	DESCRIPTION		
00 0001 0100b (014h)	RG FALL[4:0]	RG falling edge from RG rising edge ( $t_{CKP}/4 - 16t_{CKP}/100 < t_{RGW} < t_{CKP}/4 + 15t_{CKP}/100$ )		
		DATA	(DEC)	STEP
		10000b	(16)	-16
		10001b	(17)	-15
		—	—	—
		11111b	(31)	-1
		00000b	(0)	0 (default)
		00001b	(1)	1
—	—	—		
01110b	(14)	14		
01111b	(15)	15		
STEP is twos complement of data. 1 step = (1 pixel clock term)/100				

**HG1 Control**

HG1 control is described in [Figure 32](#) and [Table 31](#).

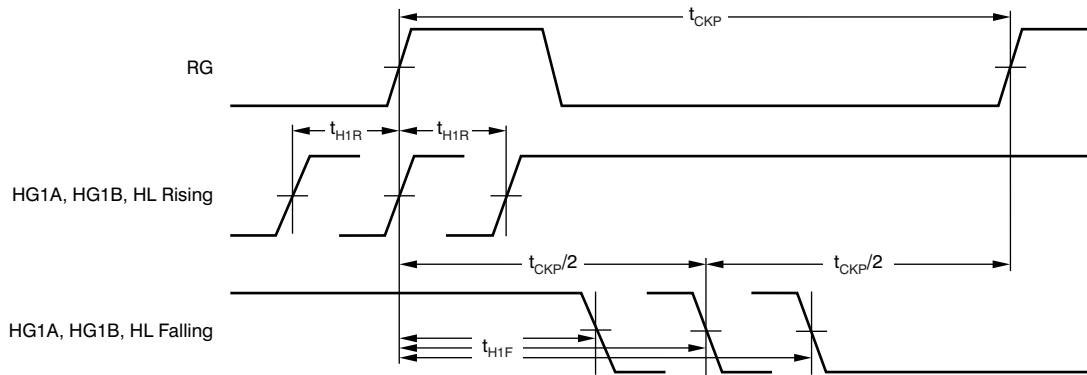

**Figure 32. HG1 Timing**

**Table 31. HG1 Register**

ADDRESS	NAME	DESCRIPTION
00 0001 0000b (010h)	HG1 RISE[4:0]	HG1A, HG1B, and HL rising edge from RG rising edge ( $-t_{CKP}/16 < t_{H1R} < t_{CKP}/15$ ) Same step control as for <a href="#">Table 30</a> . Default = 00000b.
00 0001 0001b (011h)	HG1 FALL[4:0]	HG1A, HG1B, and HL falling edge from RG rising edge ( $t_{CKP}/2 - 16t_{CKP}/100 < t_{H1F} < t_{CKP}/2 + 15t_{CKP}/100$ ) Same step control as for <a href="#">Table 30</a> . Default = 00000b.



### HG2 Control

HG2 control is described in [Figure 33](#) and [Table 32](#).

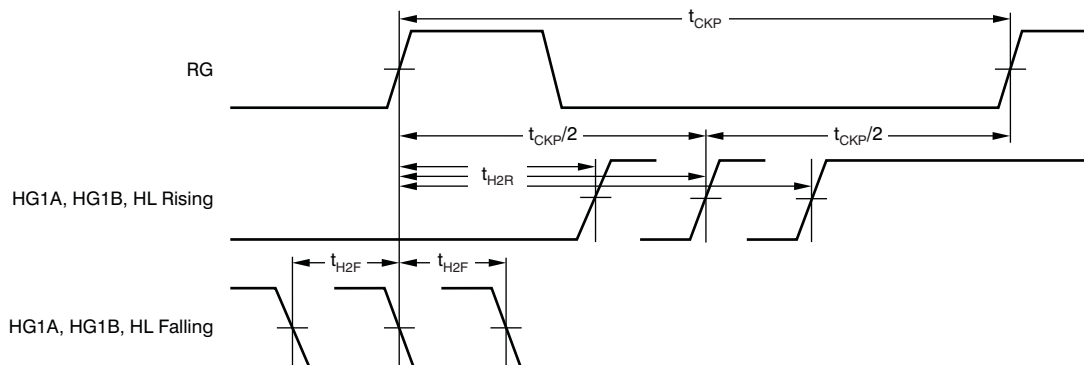

Figure 33. HG2 Timing

Table 32. HG2 Register

ADDRESS	NAME	DESCRIPTION
00 0001 0011b (013h)	HG2 RISE[4:0]	HG2A and HG2B rising edge from RG rising edge ( $t_{CKP}/2 - 16t_{CKP}/100 < t_{H2R} < t_{CKP}/2 + 15t_{CKP}/100$ ) Same step control as for <a href="#">Table 30</a> . Default = 00000b.
00 0001 0010b (012h)	HG2 FALL[4:0]	HG2A and HG2B falling edge from RG rising edge ( $-t_{CKP}16/100 < t_{H2F} < t_{CKP}15/100$ ) Same step control as for <a href="#">Table 30</a> . Default = 00000b.

### SHP Control

SHP control is described in [Figure 34](#) and [Table 33](#).

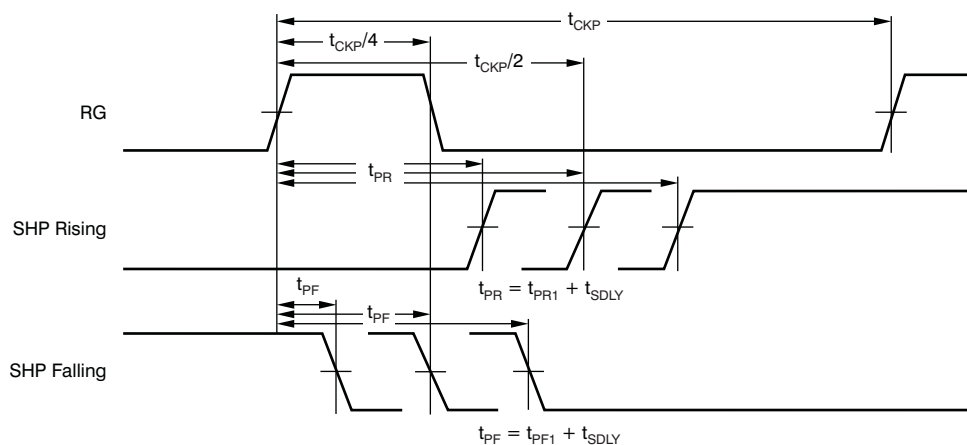

Figure 34. SHP Timing

**Table 33. SHP Register**

ADDRESS	NAME	DESCRIPTION
00 0001 0110b (016h)	SHP RISE[4:0]	SHP rising edge from RG rising edge ( $t_{CKP}/2 - 16t_{CKP}/100 < t_{PR1} < t_{CKP}/2 + 15t_{CKP}/100$ ) Same step control as for <a href="#">Table 30</a> . Default = 00000b.
00 0001 0101b (015h)	SHP FALL[4:0]	SHP falling edge from RG rising edge ( $t_{CKP}/4 - 16t_{CKP}/100 < t_{PF1} < t_{CKP}/4 + 15t_{CKP}/100$ ) Same step control as for <a href="#">Table 30</a> . Default = 00000b.
00 0000 0011b (003h)	S-DELAY[1:0]	Sampling delay for SHP/SHD ( $0 \text{ ns} < t_{SDLY} < 6 \text{ ns}$ ) 00b = 0 ns (default) 01b = 2 ns 10b = 4 ns 11b = 6 ns

**SHD Control**

SHD control is described in [Figure 35](#) and [Table 34](#).

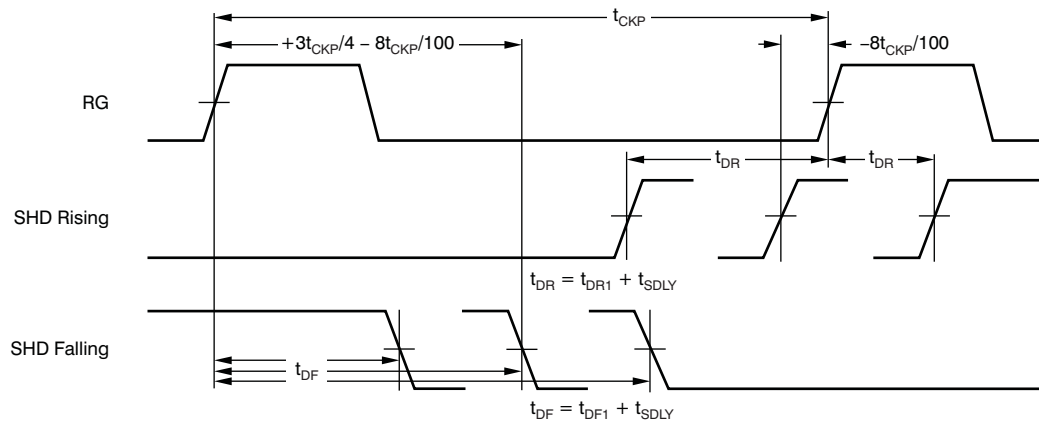

**Figure 35. SHD Timing**

**Table 34. SHD Register**

ADDRESS	NAME	DESCRIPTION
00 0001 1000b (018h)	SHD RISE[4:0]	SHD rising edge from RG rising edge ( $-24t_{CKP}/100 < t_{DR1} < 7t_{CKP}/100$ ) Same step control as for <a href="#">Table 30</a> . Default = 00000b.
00 0001 0111b (017h)	SHD FALL[4:0]	SHD falling edge from RG rising edge ( $3t_{CKP}/4 - 24t_{CKP}/100 < t_{DF1} < 3t_{CKP}/4 + 7t_{CKP}/100$ ) Same step control as for <a href="#">Table 30</a> . Default = 00000b.
00 0000 0011b (003h)	S-DELAY[1:0]	Sampling delay for SHP/SHD ( $0 \text{ ns} < t_{SDLY} < 6 \text{ ns}$ ) ( $0 \text{ ns} < t_{SDLY} < 6 \text{ ns}$ ) 00b = 0 ns (default) 01b = 2 ns 10b = 4 ns 11b = 6 ns

### ADCCK Control

ADCCK control is described in [Figure 36](#) and [Table 35](#).

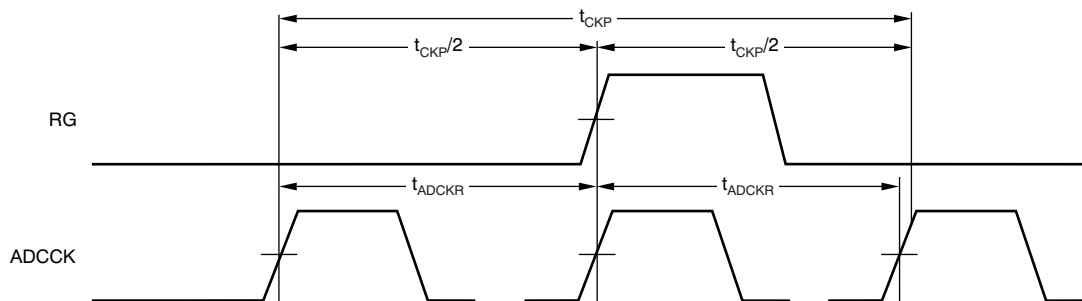

Figure 36. ADCCK Delay Timing

Table 35. ADCCK Delay Register

ADDRESS	NAME	DESCRIPTION				
00 0001 1001b (019h)	ADCCK DELAY[5:0]	ADCCK rising edge from RG rising edge ( $-50t_{MCKP}/100 < t_{ADCKR} < 49t_{MCKP}/100$ ) Default = 00 0000b.				
00 0001 1010b (01Ah)	ADCCK DELAY[6]	Data[6:0] = 01Ah[0] × 26 + 019h[5:0]				
		<b>DATA[6]</b>	<b>01Ah[0]</b>	<b>019h[5:0]</b>	<b>(DEC)</b>	<b>STEP</b>
		100 0000b	1	00 0000b	(64)	Reserved
		100 1101b	1	00 1101b	(77)	Reserved
		100 1110b	1	00 1110b	(78)	-50
		100 1111b	1	00 1111b	(79)	-49
		—	—	—	—	—
		111 1111b	1	11 1111b	(127)	-1
		000 0000b	0	00 0000b	(0)	0 (default)
		000 0001b	0	00 0001b	(1)	1
		—	—	—	—	—
		011 0000b	0	11 0000b	(48)	48
		011 0001b	0	11 0001b	(49)	49
011 0010b	0	11 0010b	(50)	Reserved		
011 1111b	0	11 1111b	(63)	Reserved		
STEP is twos complement of data. 1 step = (1 pixel clock term)/100.						

### Data Out Delay Control

Data out delay control is described in [Figure 37](#) and [Table 36](#).

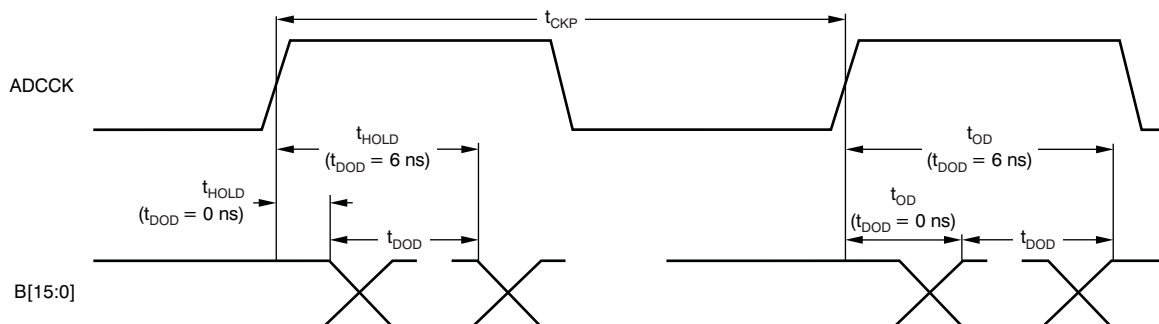

Figure 37. Data Out Delay Timing

**Table 36. Data Out Delay Register**

ADDRESS	NAME	DESCRIPTION
00 0000 0010b (002h)	DATA OUT DELAY[1:0]	Data out delay 00b to 11b (0 ns < t <sub>DOD</sub> < 6 ns) 00b = 0 ns (default) 01b = 2 ns 10b = 4 ns 11b = 6 ns

**TG INSTRUCTION HIERARCHY**

Figure 38 shows the instruction hierarchy. The VA number corresponds to the frame template, and the HA number corresponds to the line template. Each VA has a set of HA number instructions in the vertical timing memory; each HA number has a set of toggling instructions in the horizontal memory. The frame mode is selected by a register (036h).

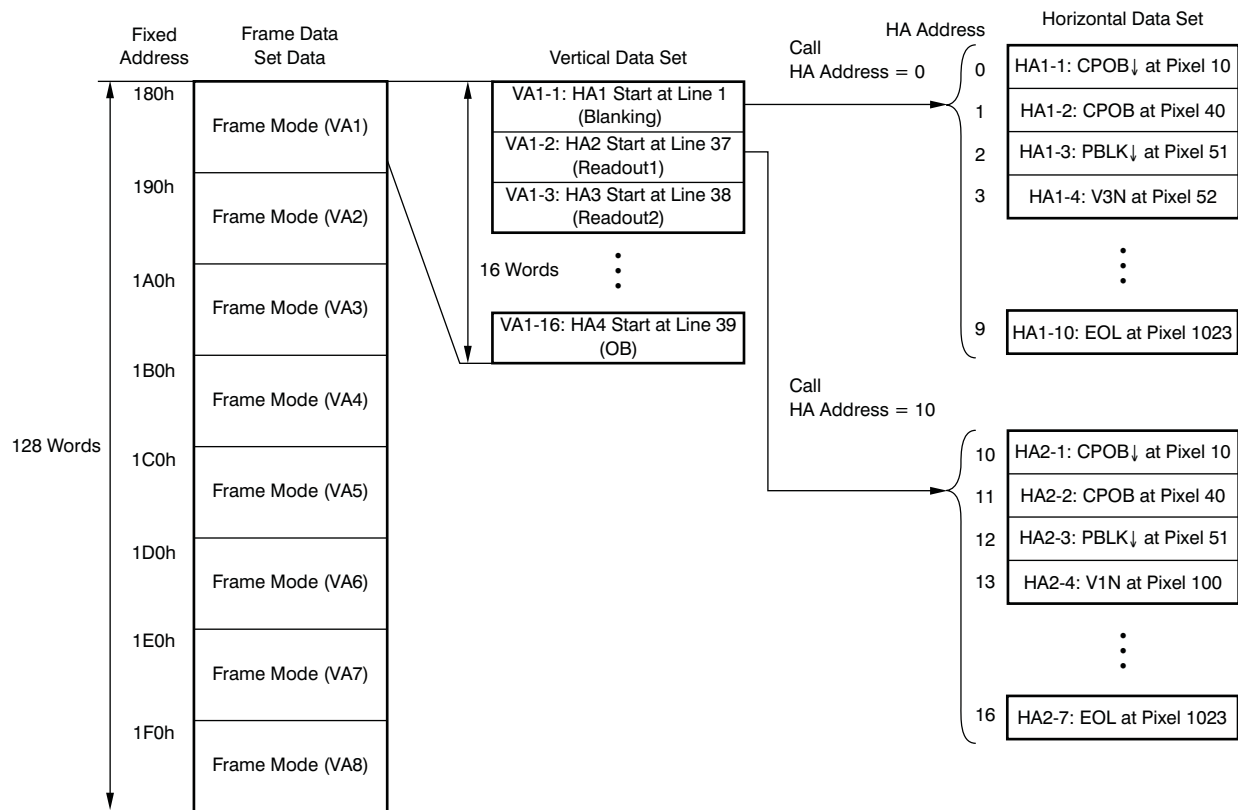

NOTE: Line number, pixel number, and start of HA address are programmable.

**Figure 38. Instruction Hierarchy (Standard Sequence Sample)**

**CCD TIMING COMPOSITION**

TG timing is composed of a vertical data set (VA) that contains eight frames. VA has a horizontal data set (HA), which has several numbers of lines for specific functions. Frame mode is provided by VA. Table 37 shows the frame number for each VA number.

**Table 37. Frame Number**

PARAMETER	FRAME							
VA number	1	2	3	4	5	6	7	8
Frame number	0	1	2	3	4	5	6	7

Operated VA is updated to the *Frame Now* register by VD. Operated VA is updated to *Frame TRIG* by the TRIG signal with a *Load TRIG frame function*. This updating process is shown in [Table 38](#).

**Table 38. Frame Mode Register**

PARAMETER	REGISTER ADDRESS	DESCRIPTION
Frame now	036h[2:0]	Set current frame number Default = 000b.
Frame TRIG	036h[5:3]	Set frame number when trigger input Default = 000b.

[Figure 39](#) shows the TG mode transition.

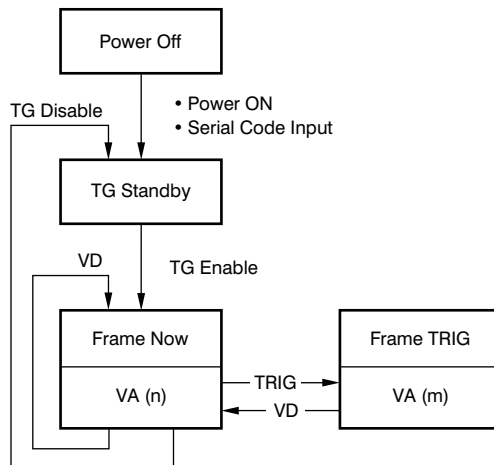

**Figure 39. TG Mode Transition**

[Figure 40](#) shows the CCD timing composition example, which consists of frames for several operation modes. Each frame counts the line count. *VD (master/slave)* or *TRIG (external trigger)* signal the reset line counter and change during the next frame.

**Table 39. TRIG Frame Function Register Setting<sup>(1)(2)</sup>**

PARAMETER	REGISTER ADDRESS	VALUE
VD frame	022h[0]	1 = Enabled
TRIG frame INCR	021h[2]	1 = Enabled
TRIG counter RST	021h[3]	1 = Enabled
Static frame number	036h[2:0]	—
TRIG frame number	036h[5:3]	7

- (1) If the TRIG function is not used, *TRIG Frame INCR* and *TRIG Counter RST* should be disabled. Refer to the [TRIG Function Section](#) of this document
- (2) Refer to the [Configuration Register](#) section for details.

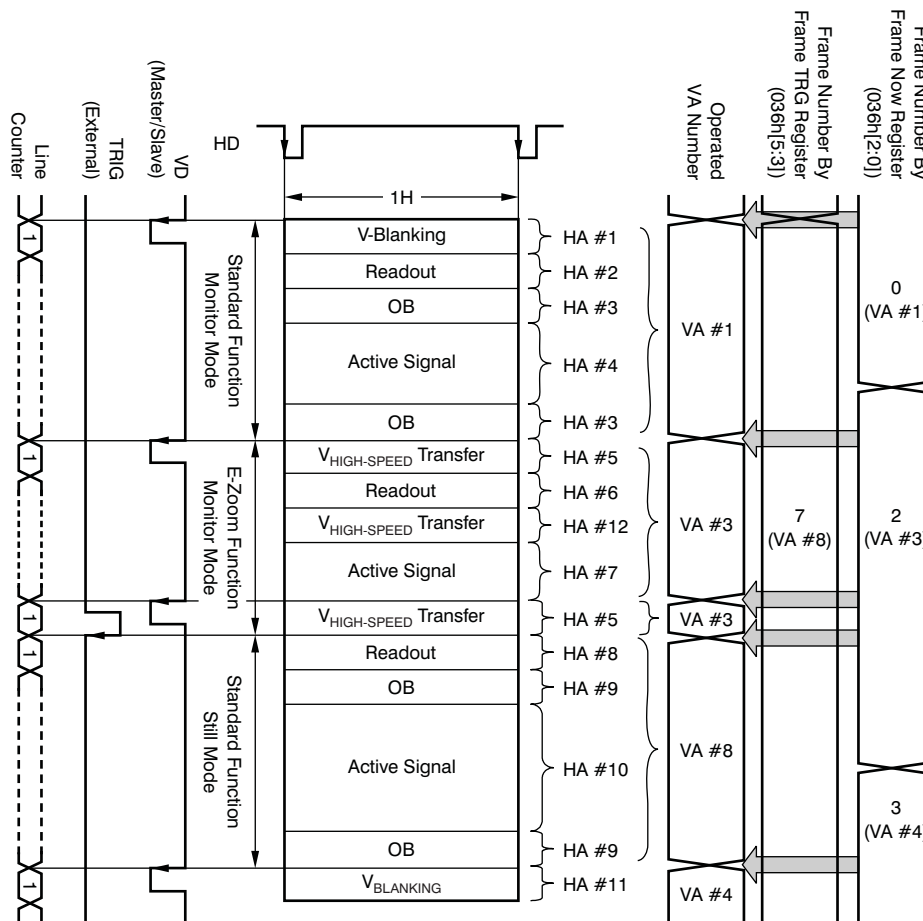

Figure 40. CCD Timing Composition (Example)

## SYNCHRONOUS FUNCTION

The system follows either the HD/VD master or slave mode. Select the master/slave mode through register setting (020h[1]: 0 = Slave, 1 = Master), as shown in Table 40. The default setting is slave mode. TG also follows an external HD/VD signal. The master mode generates HD/VD timing according to HA instruction.

Table 40. Sync Mode

MODE	REGISTER 020h[1]	HD AND VD PIN	HD AND VD TIMING	H <sub>CYCLE</sub>	V <sub>CYCLE</sub>
Slave	0 (default)	Input		Synchronous	
Master	1	Output	HA command	EOL of HA	EOF of VA

### Slave Mode

The system synchronizes the external master clock, HD, and VD. Note that the HD and VD pins are input modes.

### VD, HD Detection

VD- and HD-detected edge polarity are selected by register 020h[3]. The selected edge is detected as a rising edge of MCK. VD is detected by the HD phase. If the pixel count between the VD edge and HD edge is within the selected range, VD is detected. The range is selected as shown in [Table 41](#).

**Table 41. VD HD Detect Register<sup>(1)</sup>**

PARAMETER	REGISTER ADDRESS	DESCRIPTION
VD HD TRG edge	020h[3]	0 = Falling edge (default) 1 = Rising edge
ODD HD-VD	02Fh[2:0]	VD after HD detect range 0-7 pixel delay Default = 001b
ODD VD-HD	02Fh[5:3]	HD after VD detect range 0-8 pixel delay Default = 001b

(1) Refer to the [Slave Mode: VD, HD Specifications](#) section for details.

### H<sub>COUNTER</sub> Reset

H<sub>COUNTER</sub> reset is selected by MCK edge polarity (020h[2]). [Table 42](#) shows the register.

**Table 42. MCK Edge Polarity<sup>(1)</sup>**

PARAMETER	REGISTER ADDRESS	DESCRIPTION
VH, HD, and MCK edge	020h[2]	0 = MCK rising edge (default) 1 = MCK falling edge

(1) Refer to the [Slave Mode: VD, HD Specifications](#) section for details.

### Field Index

Field for two-field operation is detected. The detection method is selected to the *VD and HD phase* or *Register*. The *Field* output signal is selected by a register, as shown in [Table 43](#).

ODD detect range is selected by register 02Fh[5:0]. More than seven enabled instructions will always odd detect. Refer to the [Configuration Register](#) and [Slave Mode: VD, HD Specifications](#) section for details.

**Table 43. ODD/EVEN Detect Register**

PARAMETER	REGISTER ADDRESS	DESCRIPTION
Detect method	022h[3]	0 = VD/HD phase (default) 1 = Register (035h[0])
Register select	035h[0]	0 = ODD (default) 1 = EVEN
Field POL	022h[4]	0 = Low at ODD, high at EVEN (default) 1 = High at ODD, low at EVEN
VD even	022h[5]	0 = Disabled (default) 1 = Enabled

### Master Mode

The system synchronizes the external master clock, internal HD, and internal VD. Note that the HD and VD pins are output modes. HD and VD timing are provided by the HA command. H<sub>CYCLE</sub> is provided by an *end-of-line* instruction of the HA command. V<sub>CYCLE</sub> is provided by the *end-of-frame* instruction of the VA command.

## HORIZONTAL SEQUENCE

The horizontal sequence contains toggling information for 1H. Each word describes toggling information. The user must input 2-bit delay information, 2-bit toggling information, 5-bit terminal assignment, and 13-bit pixel count. TG decodes the pixel count and precedes each event sequentially according to the address. A maximum of four signals toggling at the same pixel counter are allowed using the 2-bit delay instruction.

### Horizontal Address (HA) Memory

The HA memory area is shown in [Table 44](#).

**Table 44. HA Memory Area**

PARAMETER	DESCRIPTION
Address	200h-3FFh
Memory area	512 words
Data width	22-bit

### Basic Functionality

[Table 45](#) defines the terminal assignment (5-bit) command and pixel address for toggling.

**Table 45. HA Bit Function**

21	20	19	18	17	16	15	14	13	12	11	10	9	8	7	6	5	4	3	2	1	0
Delay		Toggle		Terminal					Pixel count												
BITS		NAME		DESCRIPTION																	
21-20		DELAY		Toggling delay pixel number using two bits (0-3)																	
19-18		TOGGLE		Toggling set to high/low using two bits 00b = Low, 01b = High																	
17-13		TERMINAL		Terminal assignment using five bit. Terminal: V0N-12N, P0-5, CLPDM, CLPOB, PBLK, HBLK, HDIV, HD (master mode), and VD (master mode) Refer to the <a href="#">Signal</a> section for details.																	
12-0		PIXEL CNT		Toggling of the pixel count using 13 bits (10-8191). Bits below 9 are prohibited. Order in one HA part must be added order. Same pixel count is prohibited.																	

### General Instruction

[Table 46](#) details the  $V_{CCD}$  high-speed start and end-of-line commands.

**Table 46. HA Instruction Bit Function**

21	20	19	18	17	16	15	14	13	12	11	10	9	8	7	6	5	4	3	2	1	0
				1	1	1	1	1													
General instruction				General instruction fix					Pixel count (same as for <a href="#">Table 45</a> )												
GENERAL INSTRUCTION		NAME		DESCRIPTION																	
1111b		EOL		The end-of-line reset pixel counter is at the pixel number.																	
				Mode		Pixel Number															
				Master		Target $H_{CYCLE} - 1 + \text{register } 034h[3:0]$															
				Slave		8191															
0001b		Start HS 1		Start $V_{CCD}$ high-speed transfer (HS 1)																	
0010b		Start HS 2		Start $V_{CCD}$ high-speed transfer (HS 2)																	
0011b		Start HS 3		Start $V_{CCD}$ high-speed transfer (HS 3)																	
0100b		Start HS 4		Start $V_{CCD}$ high-speed transfer (HS 4)																	
0101b		Stop HS		Stop $V_{CCD}$ high-speed transfer																	



**V<sub>HIGH-SPEED</sub> Transfer (HS) Instruction**

Two sets of commands specify the HS start/stop information and the HS toggling pixel address information. As shown in Table 47, HS start/stop information is part of the horizontal memory. Four types of HS are available using the [21:18] bit instruction. An HA programming example is shown in Table 47. Note that sync mode is a slave mode.

**Table 47. Horizontal Memory Example**

MEMORY ADDRESS		DELAY [21:20]	TOGGLING [19:18]	TERMINAL ASSIGNMENT [17:13]	PIXEL COUNT [12:0]
FIXED [31]	SEQUENTIAL [30:22]				
1	0 0000 0000b (A1h-1h)	00b	00b	11001b (CLPOB)	0 0000 0000 1010b (10)
1	0 0000 0001b (A1h-2h)	00b	01b	11001b (CLPOB)	0 0000 0010 1000b (40)
1	0 0000 0010b (A1h-3h)	00b	00b	11011b (HBLK)	0 0000 0011 0011b (51)
1	0 0000 0011b (A1h-4h)	01b	01b	00001b (VON flexible)	0 0000 0011 1111b (63)
1	0 0000 0100b (A1h-5h)	00b	01b	00010b (V1N flexible)	0 0000 0100 0000b (64)
1	0 0000 0101b (A1h-6h)	00b	00b	00001b (VON flexible)	0 0000 0110 0100b (100)
1	0 0000 0110b (A1h-7h)	00b	00b	00010b (V1N flexible)	0 0000 1001 0110b (150)
1	0 0000 0111b (A1h-8h)	00b	01b	11011b (HBLK)	0 0000 1111 0001b (241)
1	0 0000 1000b (A1h-9h)	00b	00b	11000b (CLPDM)	0 0000 1111 1010b (250)
1	0 0000 1001b (A1h-10h)	00b	01b	11000b (CLPDM)	0 0001 0001 1000b (280)
1	0 0000 1010b (A1h-11h)	1111b (EOL)		11111b (general instruction)	1 1111 1111 1111b (8191)

Figure 41 shows the horizontal timing. Sequentially input 22-bit data for each toggling position.

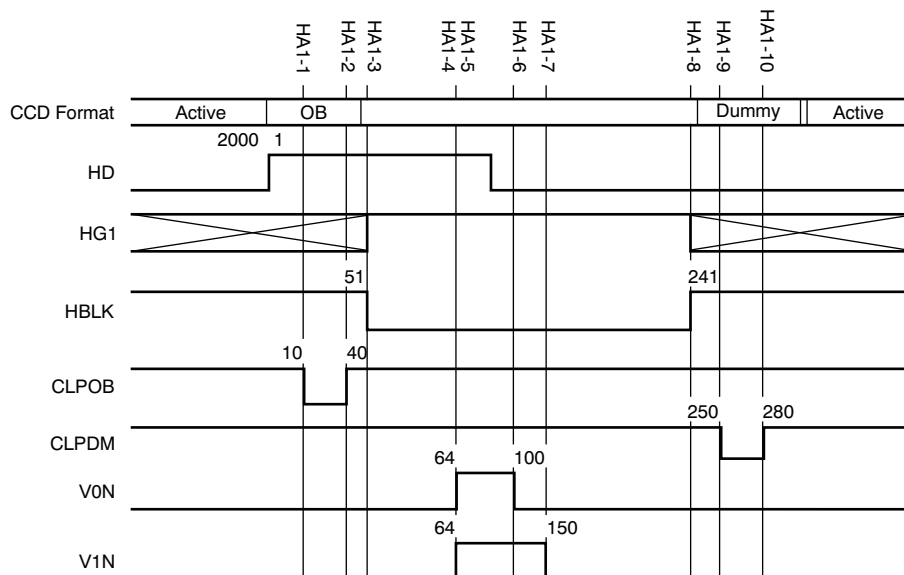

**Figure 41. Horizontal Timing Example**

## VERTICAL SEQUENCE

The vertical sequence consists of elements of the *Horizontal Sequence*. Each word contains a horizontal memory address and a line number, which is applied for the operation. The user must input 1-bit loading information, 9-bit HA address, and 12-bit line number. The TG decodes the line count and precedes each event sequentially according to the address.

### Vertical Address (VA) Memory

The VA is detailed in [Table 48](#) and [Table 49](#).

**Table 48. VA Memory Area**

PARAMETER	DESCRIPTION
Address	180h-1FFh
Memory area	128 words
Data width	22-bit

**Table 49. VA Number Start Address**

VA NUMBER	1	2	3	4	5	6	7	8
Start address	180h	190h	1A0h	1B0h	1C0h	1D0h	1E0h	1F0h

### Basic Functionality

[Table 50](#) defines the HA (horizontal address) command and HA pattern apply line number command.

**Table 50. VA Bit Function**

21	20	19	18	17	16	15	14	13	12	11	10	9	8	7	6	5	4	3	2	1	0
0																					
(1)	HA ADD										LINE										

(1)  $V_{LOAD}$ .

BITS	NAME	DESCRIPTION
21	$V_{LOAD}$	Vertical timing load, fixed at '0'
20-12	HA ADD	HA address load using 9-bit, HA address = (HA physical memory address) – 512
11-0	LINE	Line count using 12-bit (1-4095). Order in one VA must be added order. Same line count is prohibited.

**MISC Instruction**

Table 51 shows the vertical command apply line number command.

**Table 51. VA Instruction Bit Function**

21	20	19	18	17	16	15	14	13	12	11	10	9	8	7	6	5	4	3	2	1	0	
0					X	X	X	X	X													
(1)	Instruction				Don't care						LINE											

(1)  $V_{LOAD}$ .

BITS	NAME	DESCRIPTION
21	$V_{LOAD}$	Vertical timing load, fixed at '0'
11-0	LINE	Line count using 12-bit (1-4095). Order in one VA must be added order. Same line count is not prohibited.

INSTRUCTION	NAME	DESCRIPTION	
1111b	EOF	End of frame, reset line counter. In master mode, renew frame mode.	
		<b>MODE</b>	<b>LINE NUMBER</b>
		Master Slave	Target $V_{CYCLE} + 1$ 4095
0001b	Initialize	Initialize pin output at line 1. ( $V_{ON-12N}$ , P0-5, SUBN, CLPDM, CLPOB, PBLK, HBLK, HDIV, FIELD, STROBE, MSHUT, SUBSW1, and SUBSW2)	
0010b	Reserved	Reserved	
0011b	$R_{UPDATE}$	Register update. Renew TG register (H037-H0A3) at line number.	
0100b	Start event 1	Start $V_{CCD}$ high-speed transfer (dynamic mode) 1 at line number.	
0101b	Start event 2	Start $V_{CCD}$ high-speed transfer (dynamic mode) 2 at line number.	
0110b	End event	Stop $V_{CCD}$ high-speed transfer (dynamic mode) at line number.	
0111b	Frame counter reset	Frame counter reset. Reset and start frame counter at line 1.	

VA programming is shown in [Table 52](#). Sync mode is a slave mode.

**Table 52. Vertical Memory Example**

MEMORY ADDRESS		LOAD [21]	HA ADDRESS (0-511) OR INSTRUCTION [20:12]	LINE COUNT [11:0]
FIXED [31:30]	SEQUENTIAL [29:22]			
01b	1000 0000b (VA1-0)	0	0 0000 0000b (A1h)	0000 0000 0001b (01)
01b	1000 0001b (VA1-1)	1	0 0010 0000b (initialize)	0000 0000 0001b (01)
01b	1000 0010b (VA1-2)	1	0 1110 0000b (frame count reset)	0000 0000 0001b (01)
01b	1000 0011b (VA1-3)	0	0 0001 0000b (A2h)	0000 0010 0001b (33)
01b	1000 0100b (VA1-4)	0	0 0001 1101b (A3h)	0000 0010 0010b (34)
01b	1000 0101b (VA1-5)	0	0 0011 0011b (A4h)	0000 0010 0011b (35)
01b	1000 0110b (VA1-6)	0	0 0000 0001b (A1h)	0000 0010 0100b (36)
01b	1000 0110b (VA1-7)	1	1 1110 0000b (end of frame)	1111 1111 1111b (4095)

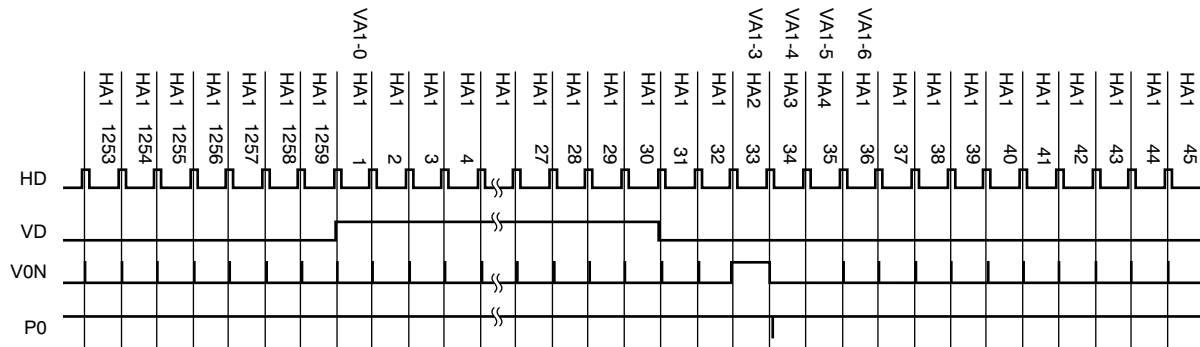

**Figure 42. Vertical Timing Example**

### VERTICAL HIGH-SPEED (HS) TRANSFER SEQUENCE

The vertical high-speed (HS) transfer shifts a charge for a specified number of lines. The still mode and electric zoom use HS. Counter start of HS has three pixel delays from the *Start HS* command of HA. The vertical high-speed transfer has both a programmed operation mode and register dynamic mode.

#### HS Memory

HS memory is described in [Table 53](#) and [Table 54](#).

**Table 53. HS Memory Area**

PARAMETER	DESCRIPTION
Address	100h-17Fh
Memory area	128 words
Data width	16-bit

**Table 54. HS Number Start Address**

HS NUMBER	1	2	3	4
Start address	100h	120h	140h	160h

## Basic Functionality

Table 55 describes the HS basic functionality.

**Table 55. HS Bit Function**

15	14	13	12	11	10	9	8	7	6	5	4	3	2	1	0
Delay		Toggle	Terminal			Pixel count									
BITS		NAME		DESCRIPTION											
15-14		DELAY		HS delay using two bits (0-3)											
13		TOGGLE		HS is set to high/low 0 = Low, 1 = High											
12-9		TERMINAL		HS pin using four bits (1-13)											
				TERMINAL NUMBER						V					
				1						V0N					
				13						V12N					
8-0		PIXEL CNT		HS toggling pixel using nine bits (1-511)											

## Instruction

Table 56 details the HS instruction.

**Table 56. HS Instruction Bit Function**

15	14	13	12	11	10	9	8	7	6	5	4	3	2	1	0
General instruction							Pixel count								
GENERAL INSTRUCTION				NAME		DESCRIPTION									
111 0000b				Repeat		Reset HS pixel counter, pixel number = target cycle – 1									

**Programmed Operation Mode**

The  $V_{HIGH-SPEED}$  transfer function is used to clear the  $V_{CCD}$ . The HS pattern is supplied in the HS memory area. The pattern can be provided four types. HS start and stop timing is provided in the HA memory area. The operation continues until a decoding stop command of HA.  $V_{TOGGLING}$  must not be provided under an HS operation.

1. Provide toggling information in HS memory.
2. Provide HS start and stop instruction in the HA memory with no  $V_{TOGGLING}$  of HA.
3. Provide the above HA to the VA memory.

**$V_{CCD}$  Clear Example**

Figure 43 shows an example of a programmable operation mode.

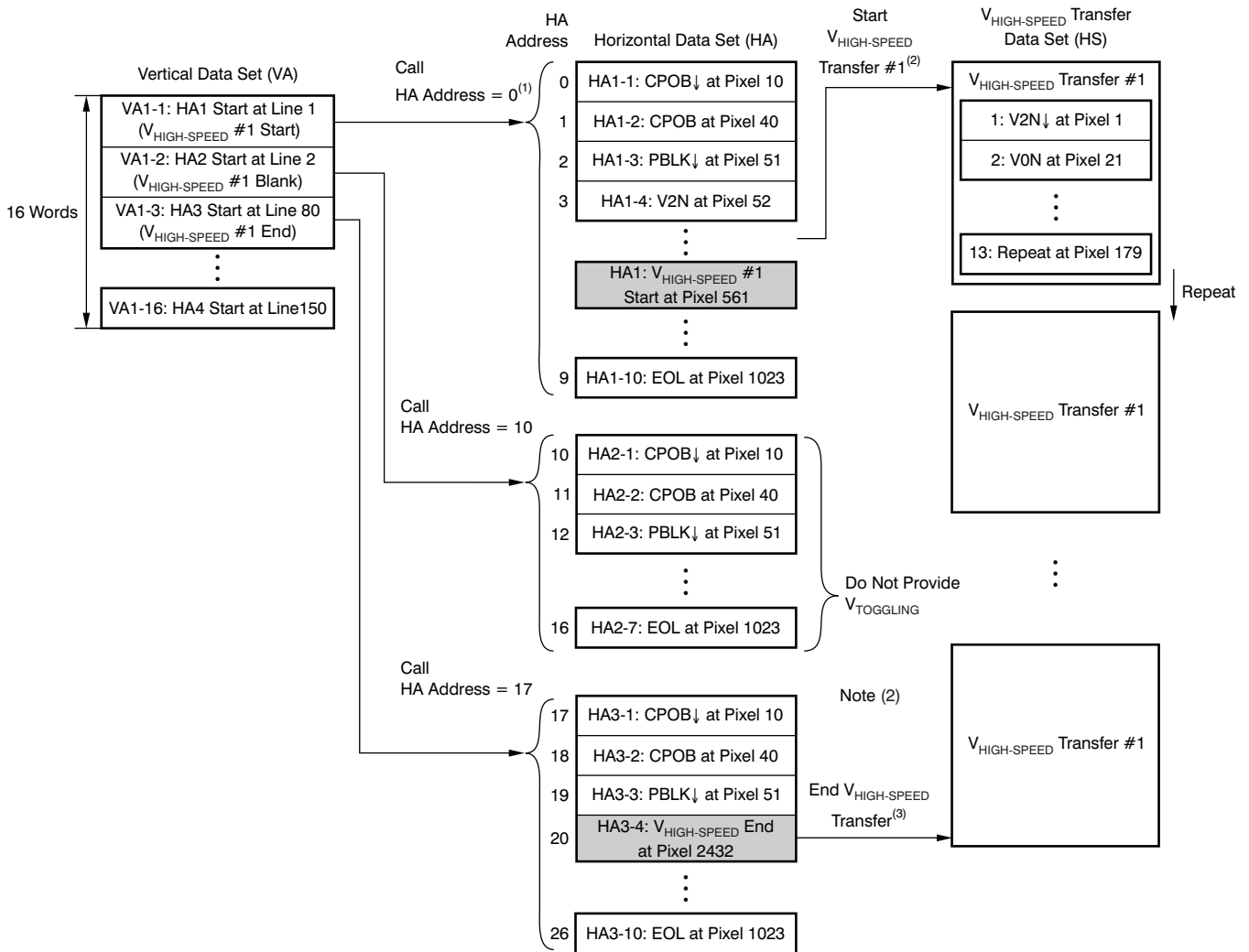

NOTE: Shaded cells indicate the area under discussion.

- (1) The HA command block is called by a VA command.
- (2) The HS loop sequence is started by an HA command at the selected pixel.
- (3) The HS loop sequence is stopped by an HA command at the selected pixel.
- (4) Line number, pixel number, and start of HA address are programmable.

**Figure 43. Programmed Operation Mode Sequence**

As shown in Table 57,  $V_{\text{HIGH-SPEED}}$  toggling pixel address information is part of the HS memory. Input toggling points for one vertical transfer and one cycle address for repeat.

Table 57. V High-Speed Toggling Memory Example

MEMORY ADDRESS		DELAY [15:14]	SET [13]	TERMINAL ASSIGNMENT [12:9]	PIXEL COUNT [8:0]
FIXED	SEQUENTIAL				
01b	0000 0000b (HS 1-1)	00b	0	0011b	0 0000 0001b (1)
01b	0000 0001b (HS 1-2)	00b	1	0001b	0 0001 0101b (21)
01b	0000 0010b (HS 1-3)	01b	0	0100b	0 0010 1001b (41)
01b	0000 0011b (HS 1-4)	00b	1	0010b	0 0011 1101b (61)
—	—	—	—	—	—
01b	0000 0100b (HS 1-5)	11b	1	0000b (repeat)	0 1011 0011 (179)

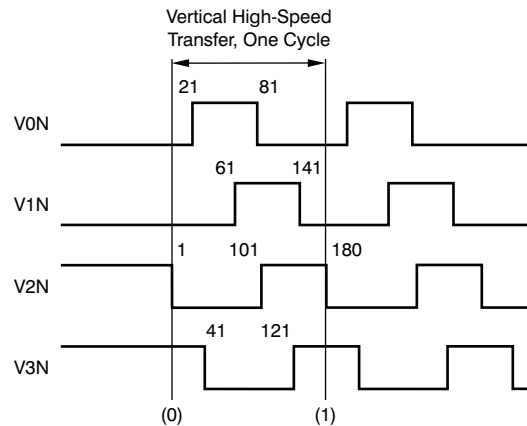

Figure 44. HS One Cycle Example

The HS start and stop command of HA is delayed by three pixel terms. Table 58 shows the delay.

Table 58. HA and HS Pixel Count

ITEM	LINE NUMBER	HA PIXEL COUNT	HS PIXEL COUNT
HA1 $V_{\text{HIGH-SPEED}}$ transfer start.	1	561	—
$V_{\text{HIGH-SPEED}}$ transfer counter start and V2 pulled low.	1	564	1
—	—	—	—
HA3 $V_{\text{HIGH-SPEED}}$ transfer stop.	80	2432	177
$V_{\text{HIGH-SPEED}}$ transfer cycle end.	80	2435	180

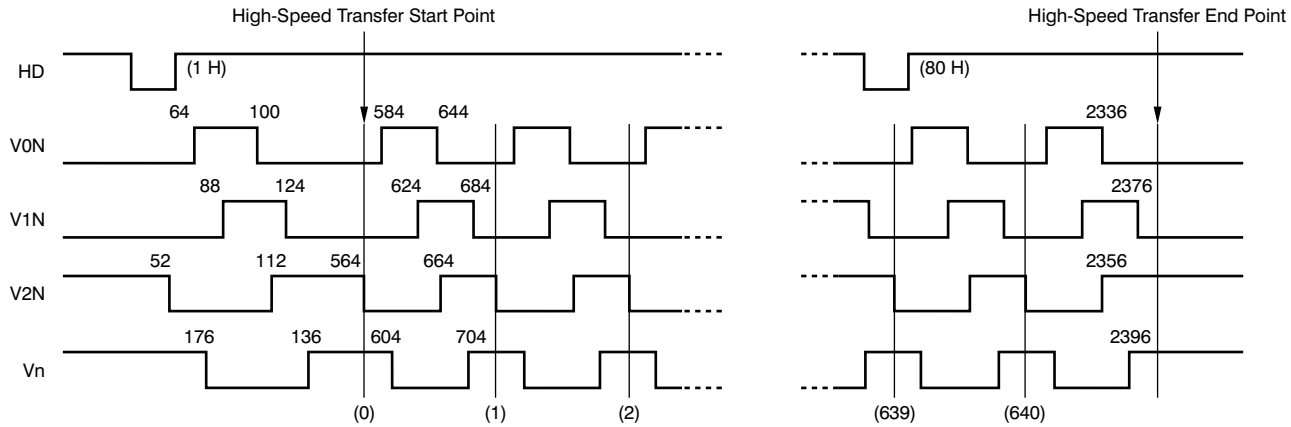
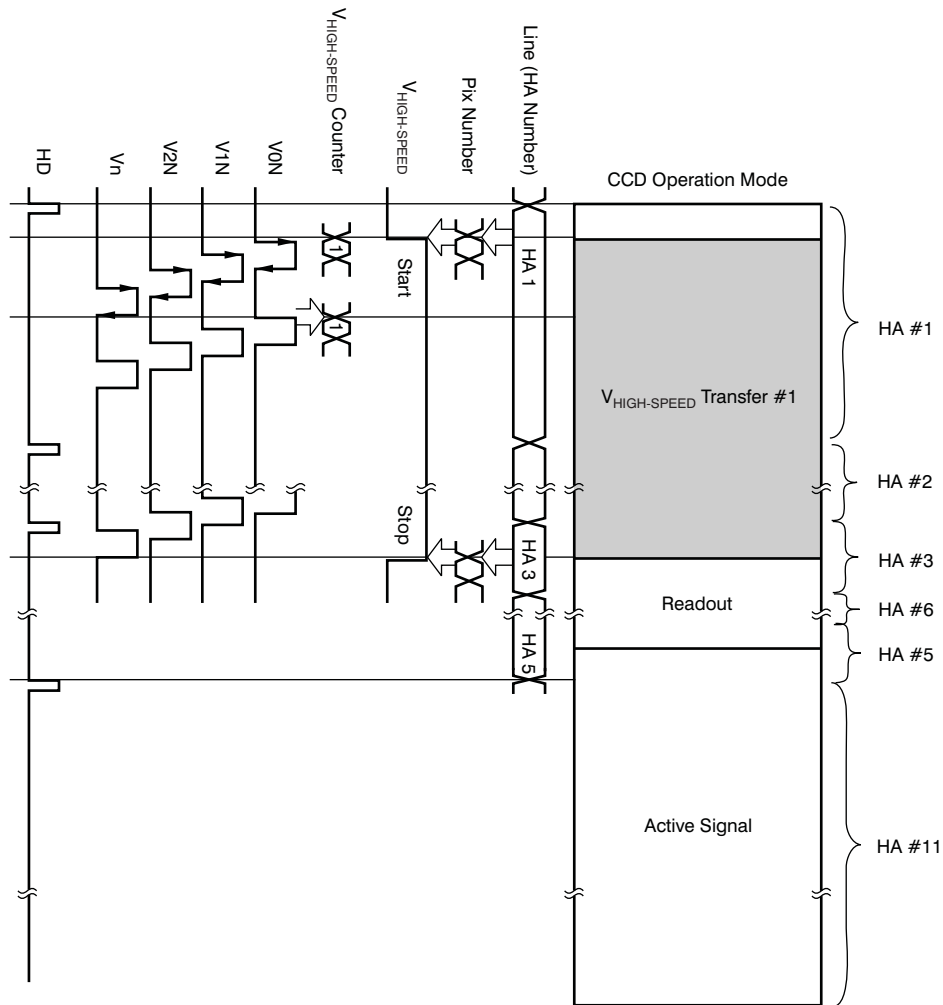

Figure 45. HS Timing Chart Example

Figure 46 shows the programmed operation mode for a still picture.



NOTE: Shaded cells indicate the area under discussion.

Figure 46. Programmed Operation Mode for A Still Picture



**Example for Electrical Zoom**

Figure 47 shows the programmed operation mode for an electric zoom function.

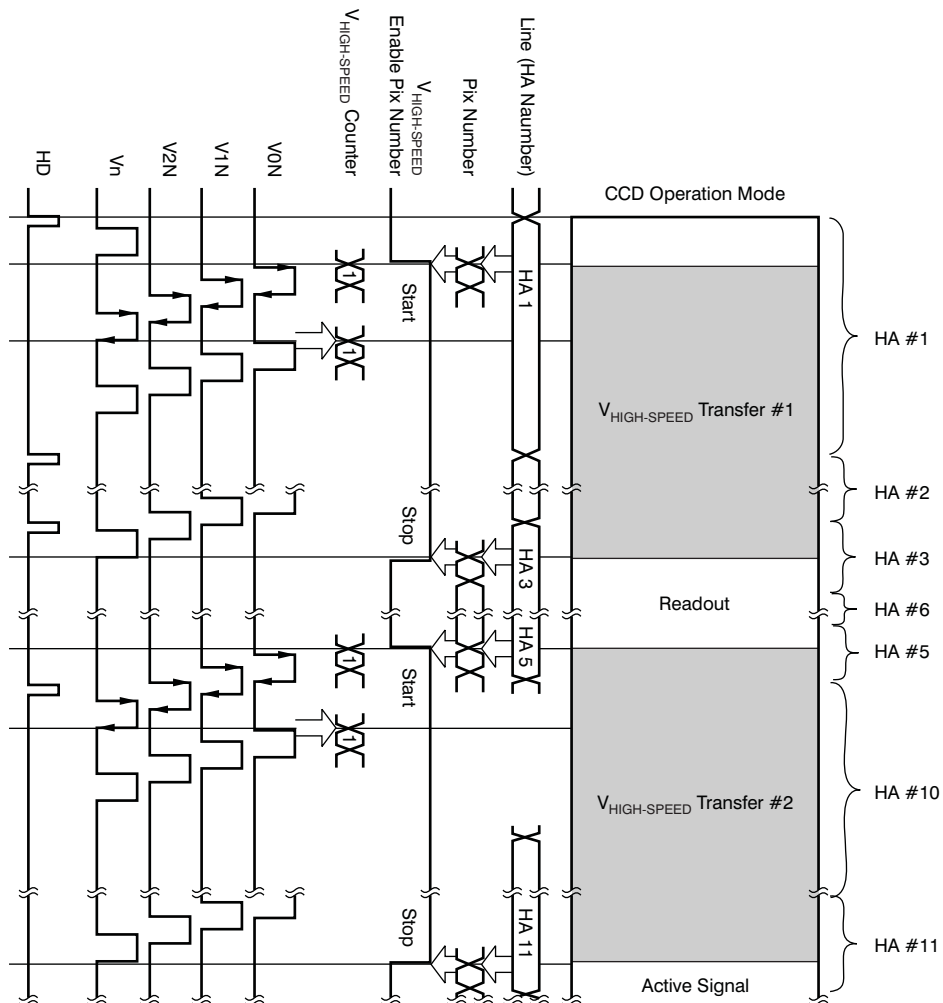

NOTE: Shaded cells indicate the area under discussion.

**Figure 47. Programmed Operation Mode for An Electric Zoom Function**

### Register Dynamic Operation Mode

The HS changes for a specified number of lines. Specifically, the electric zoom requires a dynamic adjustment of the vertical transfer line number. In addition to the programmed operation mode, the HS enables/disables the line number memory and  $V_{EVENT}$  counter; the  $V_{EVENT}$  start/stop register enables the dynamic adjustment. HS enable/disable memory is included in the vertical memory area. A  $V_{EVENT}$  start command resets the  $V_{EVENT}$  counter (bit) at a specified line count.

Follow this recommended procedure to:

1. Select the  $V_{SIGNAL}$  for the event function. All  $V_{SIGNALS}$  for a  $V_{HIGH-SPEED}$  transfer must be enabled by a register setting, as shown in [Table 59](#).
2. Select the  $V_{SIGNAL}$  for the event counter trigger. This signal counts up the event counter, as shown in [Table 60](#). The last signal of the  $V_{HIGH-SPEED}$  transfer is useful.
3. Provide toggling information in the HS memory.
4. Provide *HS start and stop* instruction in the HA memory. Refer to the [Horizontal Sequence](#) section for details.
5. Provide *Event* instruction in the VA memory. Refer to the [Vertical Sequence](#) section for details.
6. Set the event count value for an event start and stop, as shown in [Table 61](#).

**Table 59.  $V_{EVENT}$  Pin Register<sup>(1)</sup>**

PARAMETER	REGISTER ADDRESS
$V_{EVENT}$ pin	030h-032h

(1) Refer to the [Configuration Register](#) section for details.

**Table 60. Event Counter Trigger Select Register**

PARAMETER	REGISTER ADDRESS	DESCRIPTION
TRG pin	033h[4:0]	Terminal number (V0N-12N) Refer to the <a href="#">Signal</a> section for details. Default = 00000b.
TRG edge	033h[5]	0 = Rising edge (default) 1 = Falling edge

**Table 61. Event Start/Stop Register**

PARAMETER	REGISTER ADDRESS	
EVENT 1	Start	037h, 038h
	Stop	039h, 03Ah
EVENT 2	Start	03Bh, 03Ch
	Stop	03Dh, 03Eh

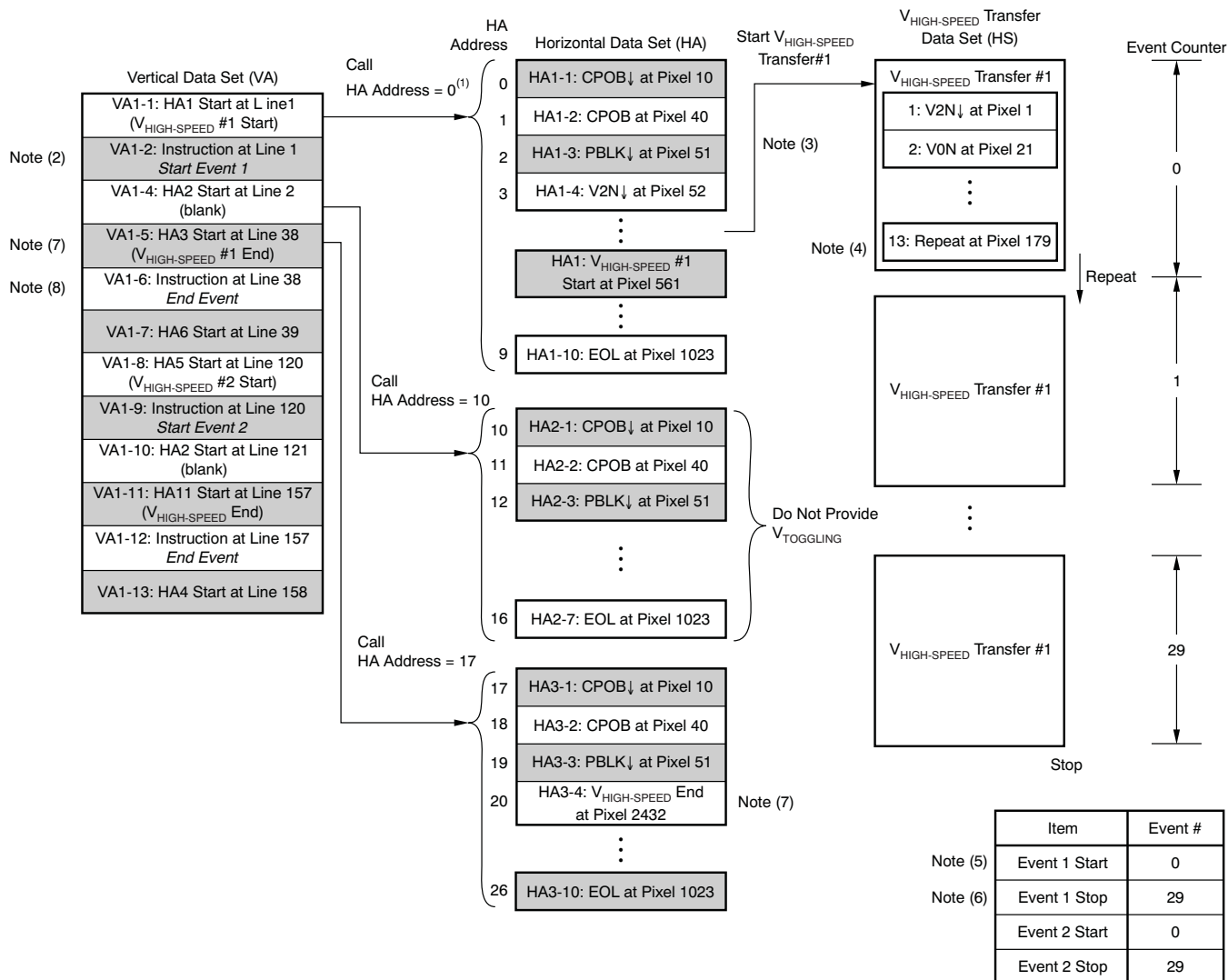

NOTE: Shaded cells indicate the area under discussion.

- (1) The HA command block is called by the VA command.
- (2) Event 1 is started by a VA command at same line number as that of note 1.
- (3) The HS loop sequence is started by an HA command at the selected pixel number. However, the vertical signal does not output.
- (4) The event counter is increased by one count a trigger vertical signal.
- (5) When the event counter reaches the value of the *Event 1 Start* register, the vertical signal starts to output.
- (6) When the event counter reaches the value of the *Event 1 Stop* register, the vertical signal stops outputting.
- (7) The HS loop sequence is stopped by an HA command at the selected pixel number.
- (8) The event is stopped by a VA command at the same line number as in note 7.
- (9) Line number, pixel number, and start of the HA address are programmable. The operation of event 2 is the same as event 1.

Figure 48. Register Dynamic Operation Mode Sequence

Table 62. Event Start/Stop<sup>(1)</sup>

PARAMETER	EVENT NUMBER
Event 1 start	0
Event 1 stop	29
Event 2 start	0
Event 2 stop	29

(1) The operation of Event 2 is the same as Event 1.

Vertical high-speed transfer has higher priority than any other vertical transfer instruction. Figure 49 shows the register dynamic operation mode for an electric zoom.

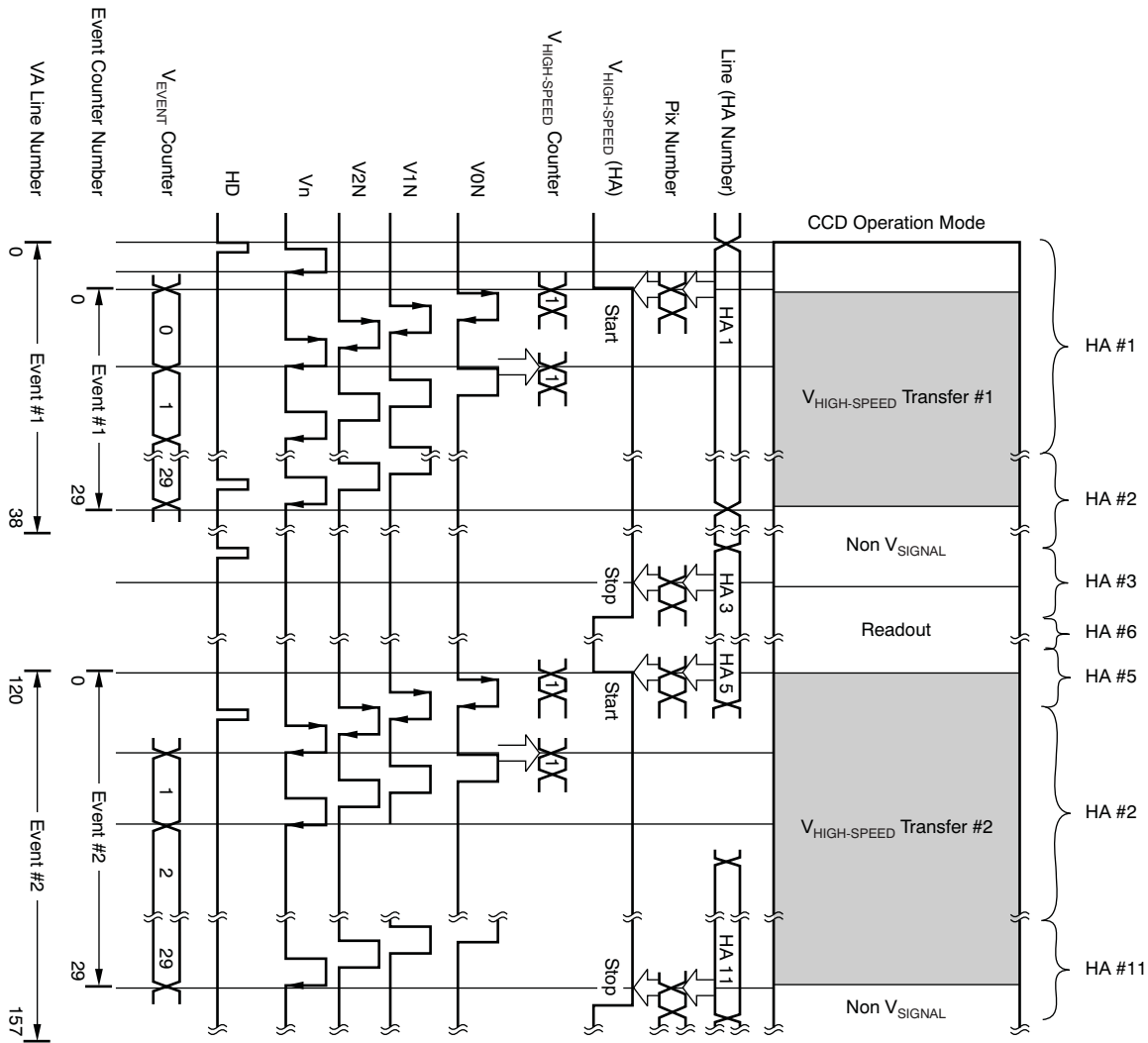

Figure 49. Register Dynamic Operation Mode for Electric Zoom Function

## FRAME COUNT FUNCTION

The frame counter counts up by '1' for each VD update event. The frame counter range is from 1 to 63. This counter value is controlled by the following functions:

- SUBSW1 and SUBSW2 control
- MSHUT control
- Strobe control

A counter reset is accomplished by the following operation. The counter value is '1' after reset.

- VA instruction (Refer to the [Vertical Sequence](#) section for details.)
- TRIG (Refer to the [Trigger Function](#) section for details.)

If the counter value reaches the maximum value (63), the value can only be changed with a frame counter reset.

**Table 63. Frame Counter Register**

PARAMETER	REGISTER ADDRESS	DESCRIPTION
Frame Counter	022h[2]	0 = Disabled (default) 1 = Enabled

## TG REGISTER UPDATE FUNCTION

Some registers of the TG section can be selected for update timing. Refer to the [Register Update](#) section of the [Common Section](#) for details.

## PIXEL COUNTER PRESET

The preset value of the horizontal sequence pixel counter is set, as shown in [Table 64](#).

**Table 64. Pixel Counter Preset Register**

PARAMETER	REGISTER ADDRESS	DESCRIPTION
Pixel Counter Preset	034h[3:0]	Slave = 6 (default) Master = 0 (recommend)

## ELECTRIC SHUTTER FUNCTION

The electric shutter is operated by the SUBN pattern setting and SUBN pattern change setting.

### SUBN Pattern Setting

The SUBN pattern has four types of toggling positions that are stored in the registers shown in [Table 65](#). Patterns 2 and 3 enable fine pitch integration time control.

**Table 65. SUBN Pattern Register<sup>(1)</sup>**

PATTERN	REGISTER ADDRESS
Point 1 pixel number and polarity	08Ch-08Eh
Point 2 pixel number and polarity	08Fh-091h
Point 3 pixel number and polarity	092h-094h
Point 4 pixel number and polarity	095h-097h

(1) Refer to the [Configuration Register](#) section for details.

The SUBN pattern is specified by each point combination, as [Table 66](#) shows.

**Table 66. SUBN Pattern Description**

PATTERN	DESCRIPTION
0	Non SUBN pulse
1	Operation of point 1 and point 2
2	Operation of point 3 and point 4
3	Operation of points 1 to 4

[Table 67](#) describes an example SUBN pattern. [Figure 50](#) shows a four-pattern example of an electric shutter.

**Table 67. SUBN Pattern Example**

TOGGLE POINT	PIXEL NUMBER	POLARITY
1	50	0
2	80	1
3	180	0
4	210	1

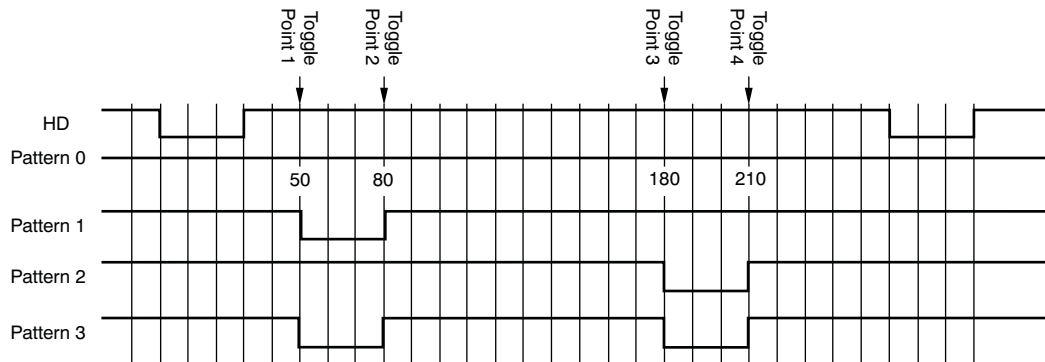

**Figure 50. Electric Shutter Four-Pattern Example**

### SUBN Pattern Change

The electric shutter function has four sequential registers, as shown in [Table 68](#). For each register, the SUBN pattern is assigned among four types of patterns and is selected at the pattern change point.

**Table 68. SUBN Pattern Change<sup>(1)</sup>**

PARAMETER	REGISTER ADDRESS
Pattern change point 1 line number and SUBN pattern number	098h-09Ah
Pattern change point 2 line number and SUBN pattern number	09Bh-09Dh
Pattern change point 3 line number and SUBN pattern number	09Eh-0A0h
Pattern change point 4 line number and SUBN pattern number	0A1h-0A3h

(1) Refer to the [Configuration Register](#) section for details.

[Table 69](#) lists an electrical shutter example method with the register update function activated.

**Table 69. Register Update Setting**

PARAMETER	REGISTER ADDRESS	VALUE
TG Update	000h[3]	1 = VA Internal instruction (R_UPDATE)

This example method has three cases of exposure time within one frame cycle. [Table 70](#) lists several electrical shutter parameters.

**Table 70. Electrical Shutter Parameter**

PARAMETER	LINE NUMBER	NOTE
SUBN operation term	A	Use with calculation of <a href="#">Table 71</a>
Exposure time	B	
Read out	C	
1 frame cycle	D	
R_UPDATE	1	Should be provided at the VA internal instruction

**Table 71. SUBN Start and End Line Number<sup>(1)</sup>**

CASE	DESCRIPTION	LINE NUMBER		
		CONDITION	SUBN_START	SUBN_END
1	Line number $1 \leq \text{SUBN\_Start} < \text{SUBN\_End} < \text{Read\_out}$	$C - B - A \geq 0$	$C - B - A$	$C - B$
2	Line number $1 \leq \text{SUBN\_End} < \text{Read\_out} < \text{SUBN\_Start}$	$(C - B \geq 0)$ and $(C - B - A < 0)$	$D + (C - B - A)$	$C - B$
3	Line number $1 < \text{Read\_out} < \text{SUBN\_Start} < \text{SUBN\_End}$	$C - B < 0$	$D + (C - B - A)$	$D + (C - B)$

(1) Line number  $\neq$  Read\_out, and Read\_out  $\neq$  SUBN\_Start  $\neq$  SUBN\_End.

An actual value example is shown in [Table 72](#).

**Table 72. Example Parameter**

PARAMETER	LINE NUMBER	VALUE
SUBN operation term	A	28
Read out	C	34
1 frame cycle	D	1259

**Table 73. Example Parameter for Each Case<sup>(1)</sup>**

CASE	DESCRIPTION	LINE NUMBER		
		INTEGRATION TIME	SUBN_START	SUBN_END
1	Line number $1 \leq \text{SUBN\_Start} < \text{SUBN\_End} < \text{Read\_out}$	$B = 2$	$C - B - A = 4$	$C - B = 32$
2	Line number $1 \leq \text{SUBN\_End} < \text{Read\_out} < \text{SUBN\_Start}$	$B = 6$	$D + (C - B - A) = 1259$	$C - B = 28$
3	Line number $1 < \text{Read\_out} < \text{SUBN\_Start} < \text{SUBN\_End}$	$B = 1229$	$D + (C - B - A) = 36$	$D + (C - B) = 64$

(1) Actual integration time is increased less than 1H by SUBN pattern three.

**Case 1: Line Number 1 ≤ SUBN\_Start < SUBN\_End < Read\_out**

**Table 74. Register Setting: Case 1**

PATTERN CHANGE POINT	LINE NUMBER	SUBN PATTERN	NOTE
1	1	0 (non SUBN)	—
2	4	1	SUBN_Start
3	31	3	—
4	32	0 (non SUBN)	SUBN_End

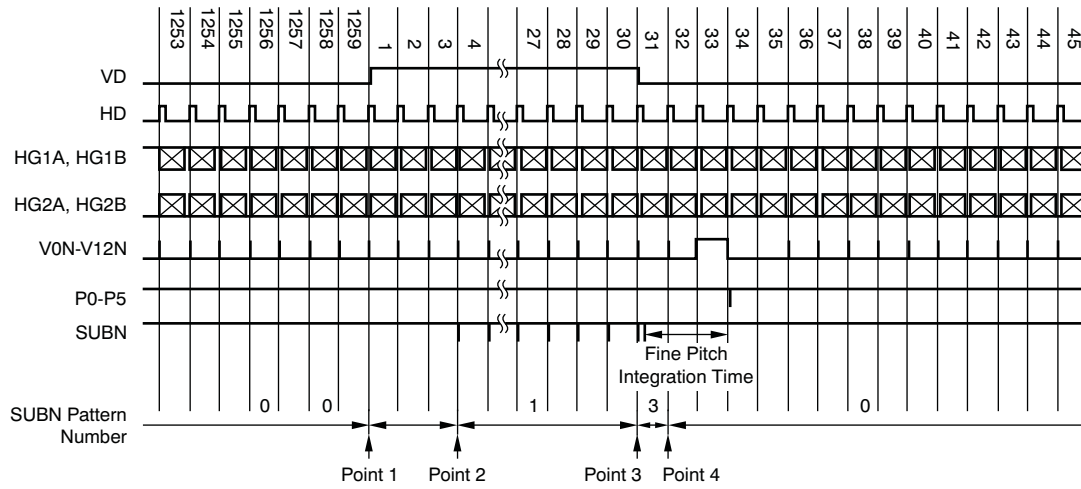
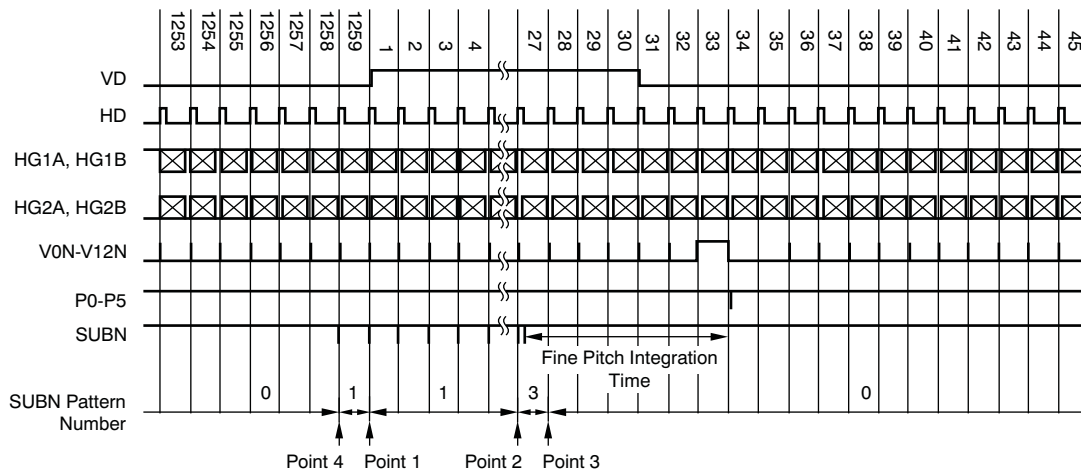

**Figure 51. Electrical Shutter Timing: Case 1**

**Case 2: Line Number 1 ≤ SUBN\_End < Read\_out < SUBN\_Start**

**Table 75. Register Setting: Case 2**

PATTERN CHANGE POINT	LINE NUMBER	SUBN PATTERN	NOTE
1	1	1	—
2	27	3	—
3	28	0 (non SUBN)	SUBN_End
4	1259	1	SUBN_Start



**Figure 52. Electrical Shutter Timing: Case 2**



Case 3: Line Number 1 < Read\_out < SUBN\_Start < SUBN\_End

Table 76. Register Setting: Case 3

PATTERN CHANGE POINT	LINE NUMBER	SUBN PATTERN	NOTE
1	1	0 (non SUBN)	—
2	36	1	SUBN_Start
3	63	3	—
4	64	0 (non SUBN)	SUBN_End

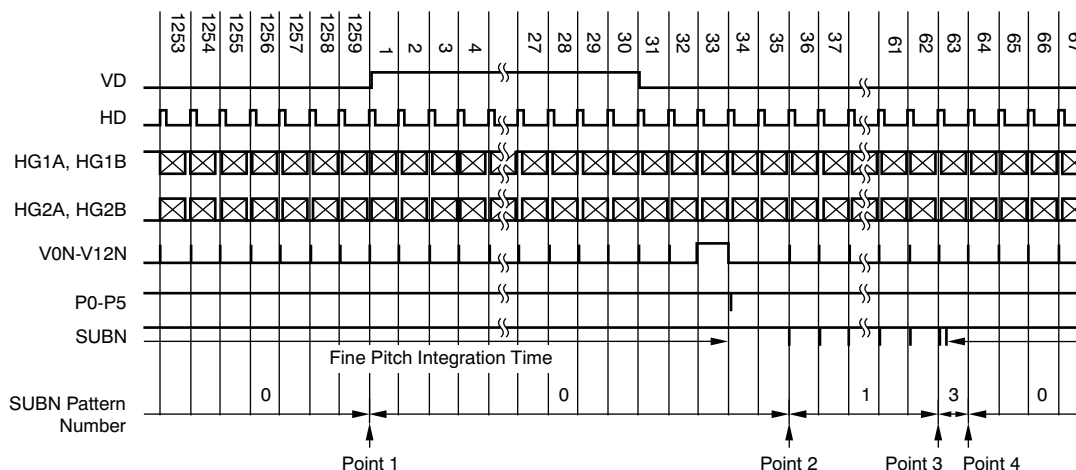

Figure 53. Electrical Shutter Timing: Case 3

SUBSW FUNCTION

The still mode uses an SUBSW1 and SUBSW2 function with two toggling registers for SUBSW1 and SUBSW2, respectively. The instruction consists of a frame number, line number, and polarity, as shown in Table 77.

Table 77. SUBSW Register<sup>(1)</sup>

PARAMETER		REGISTER ADDRESS	
SUBSW1	Point 1	Line number	07Ch, 07Dh
		Frame number	07Eh
		Polarity	07Fh
	Point 2	Line number	080h, 081h
		Frame number	082h
		Polarity	083h
SUBSW2	Point 1	Line number	084h, 085h
		Frame number	086h
		Polarity	087h
	Point 2	Line number	088h, 089h
		Frame number	08Ah
		Polarity	08Bh

(1) Refer to the Configuration Register and Frame Count Function sections for details.

Table 78 and Figure 54 show an example SUBSW register and operation, respectively.

**Table 78. SUBSW Register Example**

PARAMETER		VALUE	
SUBSW1	Point 1	Line number	1259
		Frame number	1
		Polarity	1
	Point 2	Line number	35
		Frame number	2
		Polarity	0

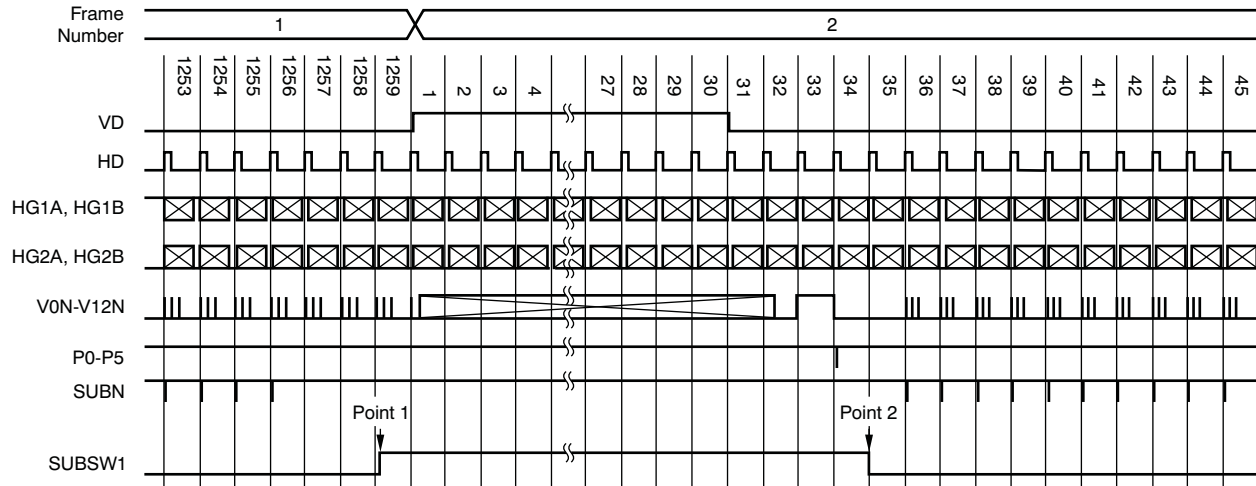

**Figure 54. SUBSW Operation Example**

## MSHUT Function

The mechanical shutter function has a total of two words. The instruction consists of a frame number, line number, pixel number, and polarity, as shown in [Table 79](#).

**Table 79. MSHUT Register<sup>(1)</sup>**

	PARAMETER	REGISTER ADDRESS
Point 1	Pixel number, line number, frame number, and polarity	040h-045h
Point 2	Pixel number, line number, frame number, and polarity	046h-04Bh

(1) Refer to the [Configuration Register](#) and [Frame Count Function](#) sections for details.

[Table 80](#) and [Figure 55](#) show an example MSHUT register and operation, respectively.

**Table 80. MSHUT Register Example**

	PARAMETER	VALUE
Point 1	Pixel number	900
	Line number	1253
	Frame number	1
	Polarity	1
Point 2	Pixel number	400
	Line number	1259
	Frame number	1
	Polarity	0

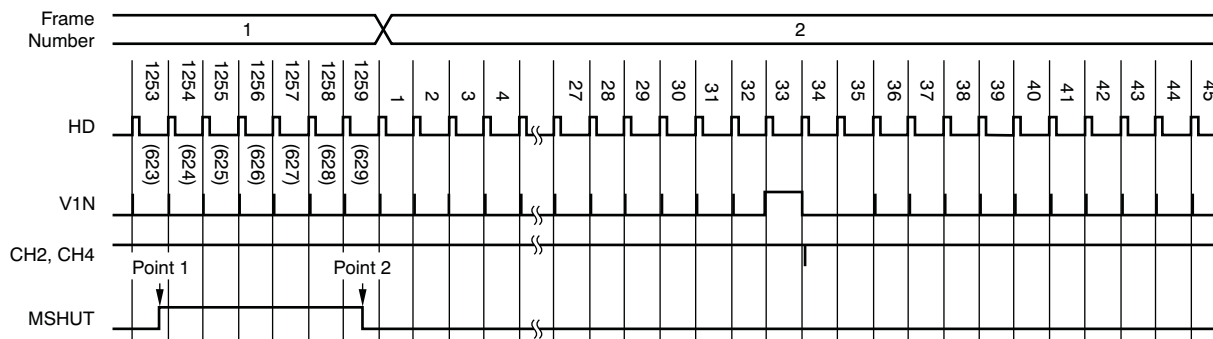

**Figure 55. MSHUT Operation Example**

## STROBE FUNCTION

The strobe shutter function has eight words. The instruction consists of a frame number, line number, pixel number, and polarity, as shown in [Table 81](#).

**Table 81. Strobe Register<sup>(1)</sup>**

	PARAMETER	REGISTER ADDRESS
Point 1	Pixel number, line number, frame number, and polarity	04Ch-051h
Point 2	Pixel number, line number, frame number, and polarity	052h-057h
Point 3	Pixel number, line number, frame number, and polarity	058h-05Dh
Point 4	Pixel number, line number, frame number, and polarity	05Eh-063h
Point 5	Pixel number, line number, frame number, and polarity	064h-069h
Point 6	Pixel number, line number, frame number, and polarity	06Ah-06Fh
Point 7	Pixel number, line number, frame number, and polarity	070h-075h
Point 8	Pixel number, line number, frame number, and polarity	076h-07Bh

(1) Refer to the [Configuration Register](#) and [Frame Count Function](#) sections for details.

Table 82 and Figure 56 show an example strobe register and operation, respectively.

**Table 82. Strobe Register Example**

PARAMETER		VALUE
Point 1	Pixel number	200
	Line number	1257
	Frame number	1
	Polarity	1
Point 2	Pixel number	500
	Line number	1
	Frame number	2
	Polarity	0
Point 3	Pixel number	800
	Line number	4
	Frame number	2
	Polarity	1
Point 4	Pixel number	300
	Line number	31
	Frame number	2
	Polarity	0

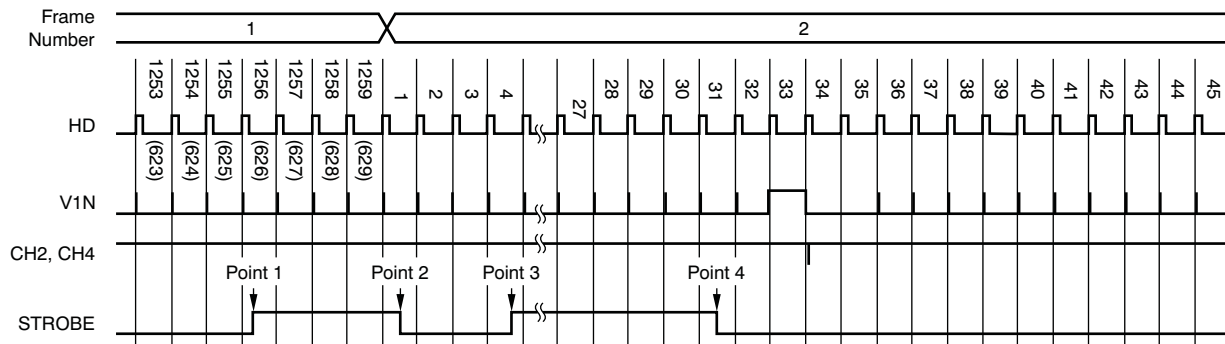

**Figure 56. Strobe Operation Example**

## HBLK FUNCTION

The horizontal blanking signal (HBLK) controls the H1, H2, and HL outputs. H1 and HL are high and H2 is low during blanking time. HBLK timing is provided by HA memory command. An example HBLK timing sequence is shown in Figure 57.

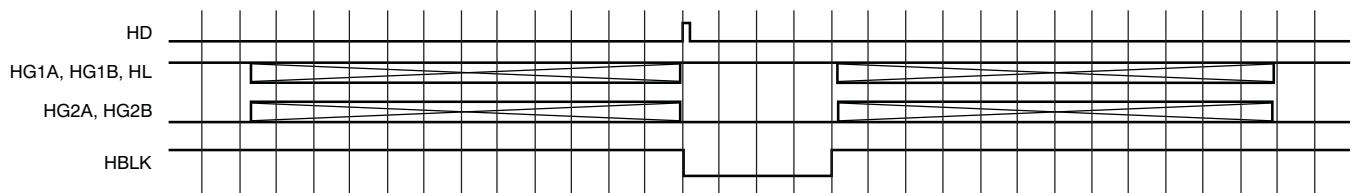

**Figure 57. Horizontal Blanking Timing Example**

## HDIV FUNCTION

The motion picture CCD requires horizontal transfer during horizontal blanking. Select the horizontal transfer clock rate (divide H clock) from 2, 4, 6, 8, 10, or 12 by register (01Bh[2:0]). HDIV timing is provided by HA memory command. An example HDIV timing is shown in Figure 58.

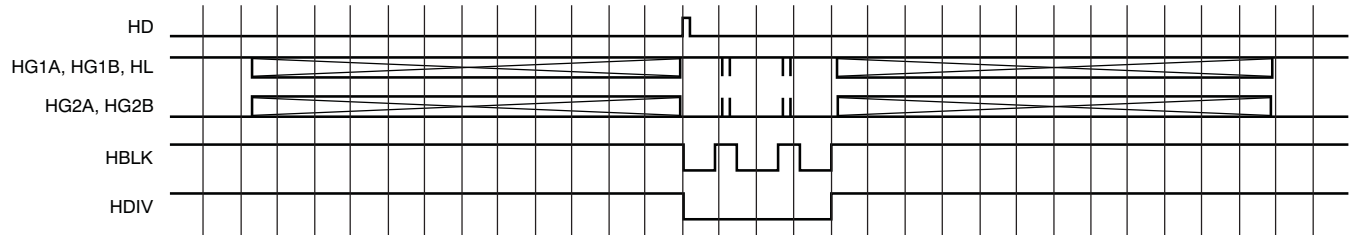

Figure 58. Motion Picture CCD Timing Example

## SHP/SHD SKIPPING

An SHP and SHD skipping function is supported by VSP01M01 and VSP01M02. The skipping ratio is selected by the register, as shown in Table 83.

Table 83. SHP and SHD Skipping Register<sup>(1)</sup>

PARAMETER	REGISTER ADDRESS
SHP/SHD skipping	01Dh, 01Eh

(1) Refer to the [Configuration Register](#) section for details.

## TRIGGER FUNCTION

### Load TRIG Frame

The TRIG frame number is operated by the falling edge of the TRIG signal. The required register setting is shown in Table 84. For an example, refer to the [CCD Timing Composition](#) section.

Table 84. Load TRIG Frame Register Setting<sup>(1)</sup>

PARAMETER	REGISTER ADDRESS	VALUE
TRIG frame INCR	021h[2]	1 = Enabled
TRIG counter RST	021[3]	1 = Enabled
TRIG frame number	036h[5:3]	1-7

(1) Refer to the [Configuration Register](#) section for details.

### TG Stop

TG is stopped by a TRIG signal polarity. The required register setting is shown in Table 85.

Table 85. TG Stop Register Setting<sup>(1)</sup>

PARAMETER	REGISTER ADDRESS	VALUE
MCK detect	020h[4]	0 = Disabled
TG CLK stop	021h[1]	1 = Enabled
TRIG POL	021h[0]	0 = High or 1 = Low

(1) Refer to the [Configuration Register](#) section for details.

Figure 59 shows a CCD timing composition example that operates the *Long Time Exposure by TRIG*. The falling edge of the TRIG (external trigger) signal reset line counter changes during the next frame. TG is stopped when the TRIG signal is high.

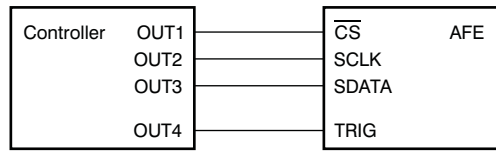
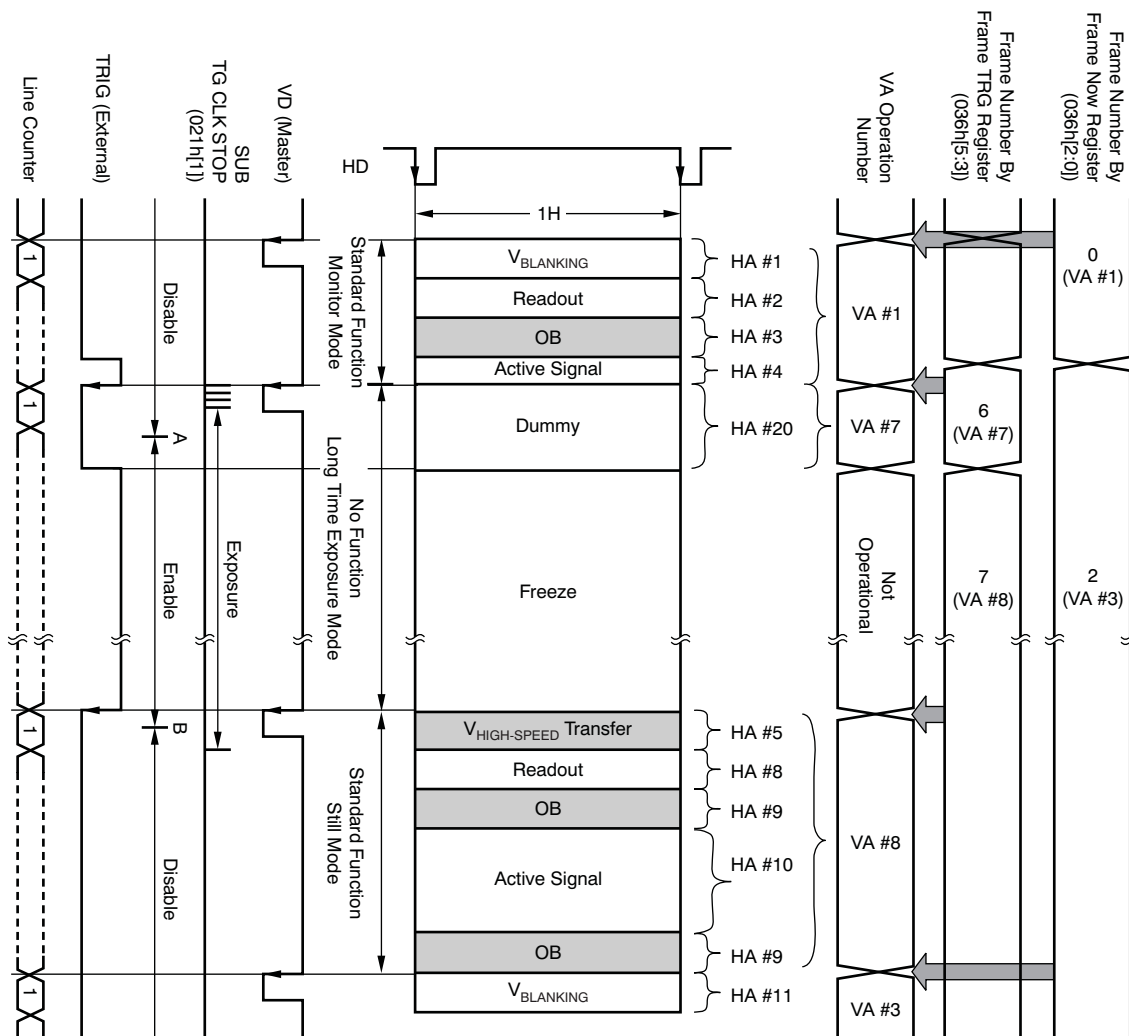

Figure 59. TRIG Signal Connection Example

Table 86. Long-Time Exposure by TRIG Example<sup>(1)</sup>

PARAMETER	REGISTER ADDRESS	VALUE
VD frame	022h[0]	1 = Enabled
TRIG frame INCR	021h[2]	1 = Enabled
TRIG counter RST	021h[3]	1 = Enabled
Static frame number	036h[2:0]	0 or 2
TRIG frame number	036h[5:3]	6 or 7
MCK detect	020h[4]	0 = Disabled
TG CLK stop	021h[1]	0 = Disabled 1 = Enabled (between A and B)
TRIG POL	021h[0]	0 = High

(1) Refer to the [Configuration Register](#) section for details.



NOTE: Shaded cells indicate the area under discussion.

Figure 60. Long-Time Exposure by TRIG Example

### Frame Counter Reset

The frame counter is reset by the falling edge of the TRIG signal. The required register setting is shown in Table 87.

Table 87. Frame Counter Reset Register Setting<sup>(1)</sup>

PARAMETER	REGISTER ADDRESS	VALUE
Frame counter	022h[2]	1 = Enabled
Frame RST	021h[4]	1 = Enabled
TRIG counter RST	021h[3]	1 = Enabled

(1) Refer to the Configuration Register section for details.

## V<sub>DRIVER</sub> SECTION

### Signal Connection and Truth Table

#### 3-State Output

Table 88. 3-State Output

INPUT (TG OUTPUT)		OUTPUT (DEVICE PIN OUTPUT)
SIGNAL NAME		SIGNAL NAME
VxN	Px	
V1N	P1	
V3N	P2	
	P4	
V5N	P3	
	P5	
TRUTH TABLE		LEVEL
VxN	Px	
Low	Low	VH
	High	VM
High	Low	Hi-Z
	High	VL

#### 2-State Output

Table 89. 2-State Output

INPUT (TG OUTPUT)		OUTPUT (DEVICE PIN OUTPUT)
SIGNAL NAME		SIGNAL NAME
VxN		
V2N		V2
V4N		V4
V6N		V6
TRUTH TABLE		LEVEL
VxN		
Low		VM
High		VL

#### SUB 2-State Output

Table 90. SUB 2-State Output

INPUT (TG OUTPUT)		OUTPUT (DEVICE PIN OUTPUT)
SIGNAL NAME		SIGNAL NAME
SUBN		SUB
TRUTH TABLE		LEVEL
SUBN		
Low		VH
High		VL

#### Output

Hi-Z = high impedance

VH = high level

VM = middle level

VL = low level



## CONFIGURATION REGISTER

The 6-bit register area is described in [Table 91](#). The addresses range from 000h to 0BFh.

**Table 91. Register Section Overview**

	SECTION	REGISTER ADDRESS		UPDATE METHOD
		DEC	HEX	
Common	Update	0	000h	Real time
AFE	Standby	1	001h	Real Time, VD, or R <sub>LOAD</sub> (selected by 000h[2:0])
	Data out	2	002h	
	S-delay	3	003h	
	OB clamp	4	004h	
	Hot-pixel rejection	5	005h	
	DPGA	6, 7	006h, 007h	
	CDS gain	8	008h	
	IDAC power	9	009h	
	DAC1 input	10, 11	00Ah, 00Bh	
	DAC2 input	12, 13	00Ch, 00Dh	
TG	High-speed timing	16-24	010h-018h	Real time
	ADCCK rise	25, 26	019h, 01Ah	
	HG1/HG2	27	01Bh	
	HG drive	28	01Ch	
	SHP/SHD pix skip	29, 30	01Dh, 01Eh	
	TG enable and sync	32	020h	
	TRG	33	021h	
	Frame field	34	022h	
	Pin enable	35-40	023h-028h	
	Pin initialize	41-46	029h-02Eh	
	ODD range	47	02Fh	Real time
	V <sub>EVENT</sub> pin	48-51	030h-033h	
	Pixel counter	52	034h	
	Field	53	035h	VD or F <sub>LOAD</sub> (selected by 022h[1:0]) TRIG is input when h021h[2] is enabled
	Frame	54	036h	
	V <sub>EVENT</sub>	55-62	037h-03Eh	Real Time or R_Update (selected by 000h[3])
	Mech shut	64-75	040h-04Bh	
	Strobe	76-123	04Ch-07Bh	
	SUBSW1	124-131	07Ch-083h	
	SUBSW2	132-139	084h-08Bh	
SUBN	140-151	08Ch-097h		
SUBN CHG	152-163	098h-0A3h		
Monitor pin select	181	0B5h		

**Detailed Common Section**

SECTION	ADDRESS		PARAMETER			DESCRIPTION		UPDATE METHOD
	DEC	HEX	BITS	PARAMETER	# OF BITS	DESCRIPTION	VALUE	
Update	0	—	—	—	—	—	0 = Real time 1 = External trigger (R <sub>LOAD</sub> pin or VD)	Real time
			[2:1]	AFE UP POL	2	AFE register update signal and polarity	00b = R <sub>LOAD</sub> input rising edge (default) 01b = R <sub>LOAD</sub> input falling edge 10b = VD rising edge 11b = VD falling edge	
			[3]	TG update	1	TG register update timing	0 = Real time 1 = VA internal instruction (R_UPDATE) (default)	
			[5:4]	—	2	—	Reserved Default = 00b	

**Detailed AFE Section**

SECTION	ADDRESS		PARAMETER			DESCRIPTION				UPDATE METHOD	
	DEC	HEX	BITS	PARAMETER	# OF BITS	DESCRIPTION	VALUE				
Standby	1	1	[0]	AFE standby	1	AFE standby	0 = AFE functions normally (default) 1 = AFE standby			Real time, VD, or R <sub>LOAD</sub> (selected by 000h[2:0])	
			[1]	8-bit DAC1 standby	1	Independent 8-bit DAC1 standby	0 = Enabled 1 = Standby (default)				
			[2]	8-bit DAC2 standby	1	Independent 8-bit DAC2 standby					
			[3]	Monitor pin	1	Monitor pin enable	0 = Disabled (default) 1 = Enabled				
			[5:4]	—	2	—	Reserved Default = 00b				
Data out	2	2	[1:0]	Data out delay	2	Data out delay	00b = 0 ns (default) 01b = 2 ns 10b = 4 ns 11b = 6 ns			Real time, VD, or R <sub>LOAD</sub> (selected by 000h[2:0])	
			[2]	$\overline{OE}$	1	Data output enable	0 = Enabled (default) 1 = Disabled (high impedance)				
			[5:3]	—	3	—	Reserved Default = 000b				
S-DELAY	3	3	[1:0]	←	2	Sampling delay for SHP/SHD internal delay circuit	00b = 0 ns (default) 01b = 2 ns 10b = 4 ns 11b = 6 ns			Real time, VD, or R <sub>LOAD</sub> (selected by 000h[2:0])	
			[5:2]	—	4	—	Reserved Default = 0000b				
OB clamp	4	4	[4:0]	←	5	OB clamp level	<b>DATA</b>	<b>(DEC)</b>	<b>12-BIT</b>	<b>10-BIT</b>	Real time, VD, or R <sub>LOAD</sub> (selected by 000h[2:0])
							00000b	(0)	64	16	
							00001b	(1)	72	18	
							—	—	—	—	
							00110b	(6)	112	28	
							00111b	(7)	120	30	
							01000b	(8)	128	32 (default)	
							01001b	(9)	136	34	
							—	—	—	—	
							01110b	(14)	176	44	
01111b	(15)	184	46								
—	—	—	—								
11110b	(30)	304	76								
11111b	(31)	312	78								
Step	—	8	2								
[5]	—	1	—	Reserved Default = 0							
Hot-pixel rejection	5	5	[4:0]	HOT PIX LEVEL	5	Hot-pixel rejection level	R <sub>L</sub> (LSB) = 16 × (code[4:0] + 1) (R <sub>L</sub> is the difference from OB level of 10-bit equivalent)			Real time, VD, or R <sub>LOAD</sub> (selected by 000h[2:0])	
			[5]	HOT PIX EN	1	Hot-pixel rejection enable/disable	0 = Disabled (default) 1 = Enabled				

**Detailed AFE Section (continued)**

SECTION	ADDRESS		PARAMETER			DESCRIPTION	DESCRIPTION			UPDATE METHOD			
	DEC	HEX	BITS	PARAMETER	# OF BITS		DATA	VALUE	GAIN				
DPGA	6	6	[5:0]	LSB	←	10	Digital programmable gain			Real time, VD, or R <sub>LOAD</sub> (selected by 000h[2:0])			
	7	7	[3:0]	MSB									
		[5:4]	—	2	—	Reserved Default = 00b							
CDS gain	8	8	[2:0]	←	3	Analog programmable gain	000b = 0 dB (default) 001b = 6 dB 010b = 12 dB 011b = 18 dB 111b = -3 dB		Real time, VD, or R <sub>LOAD</sub> (selected by 000h[2:0])				
			[5:3]	—	3	—	Reserved Default = 000b						
IDAC power	9	9	[1:0]	←	2	IDAC output current	00b = '1' (default) 01b = " 10b = " 11b = "		Real time, VD, or R <sub>LOAD</sub> (selected by 000h[2:0])				
			[5:2]	—	4	—	Reserved Default = 0000b						
DAC1 input	10	A	[5:0]	LSB	←	8	Independent DAC1 input code	<b>DATA</b>	<b>OUT (V)</b>	Real time, VD, or R <sub>LOAD</sub> (selected by 000h[2:0])			
	11	B	[1:0]	MSB			Out (V) = 0.01094 × data + 0.1 Default = 0 (DEC)						
[5:2]			—	4	—	Reserved Default = 0000b							
DAC2 input	12	C	[5:0]	LSB	←	8	Independent DAC2 input code	<b>DATA</b>	<b>OUT (V)</b>	Real time, VD, or R <sub>LOAD</sub> (selected by 000h[2:0])			
	13	D	[1:0]	MSB			Out (V) = 0.01094 × data + 0.1 Default = 0 (DEC)						
[5:2]			—	4	—	Reserved Default = 0000b							
—	14	E	[5:0]	—	6	—	Reserved Default = 0 (DEC)		Real time, VD, or R <sub>LOAD</sub> (selected by 000h[2:0])				
—	15	F	[5:0]	—	6	—	Reserved Default = 0 (DEC)		Real time, VD, or R <sub>LOAD</sub> (selected by 000h[2:0])				

Detailed TG Section

SECTION	ADDRESS		PARAMETER			DESCRIPTION				UPDATE METHOD																											
	DEC	HEX	BITS	PARAMETER	# OF BITS	DESCRIPTION	VALUE																														
High-speed timing	16	10	[4:0]	HG1 rising	5	HG1A, HG1B, HL rising edge	<table border="1"> <thead> <tr> <th>DATA</th> <th>(DEC)</th> <th>STEP</th> </tr> </thead> <tbody> <tr> <td>10000b</td> <td>(16)</td> <td>-16</td> </tr> <tr> <td>10001b</td> <td>(17)</td> <td>-15</td> </tr> <tr> <td>—</td> <td>—</td> <td>—</td> </tr> <tr> <td>11111b</td> <td>(31)</td> <td>-1</td> </tr> <tr> <td>00000b</td> <td>(0)</td> <td>0 (default)</td> </tr> <tr> <td>00001b</td> <td>(default)</td> <td>1</td> </tr> <tr> <td>—</td> <td>(1)</td> <td>—</td> </tr> <tr> <td>01110b</td> <td>(14)</td> <td>14</td> </tr> <tr> <td>01111b</td> <td>(15)</td> <td>15</td> </tr> </tbody> </table>	DATA	(DEC)	STEP	10000b	(16)	-16	10001b	(17)	-15	—	—	—	11111b	(31)	-1	00000b	(0)	0 (default)	00001b	(default)	1	—	(1)	—	01110b	(14)	14	01111b	(15)	15
			DATA	(DEC)	STEP																																
	10000b	(16)	-16																																		
	10001b	(17)	-15																																		
	—	—	—																																		
	11111b	(31)	-1																																		
	00000b	(0)	0 (default)																																		
	00001b	(default)	1																																		
	—	(1)	—																																		
	01110b	(14)	14																																		
	01111b	(15)	15																																		
	[5]	—	1	Reserved																																	
17	11	[4:0]	HG1 falling	5	HG1A, HG1B, HL falling edge																																
		[5]	—	1	Reserved																																
18	12	[4:0]	HG2 falling	5	HG2A, HG2B, falling edge																																
		[5]	—	1	Reserved																																
19	13	[4:0]	HG2 rising	5	HG2A, HG2B, rising edge																																
		[5]	—	1	Reserved																																
20	14	[4:0]	RG falling	5	RG falling edge																																
		[5]	—	1	Reserved																																
21	15	[4:0]	SHP falling	5	SHP falling edge																																
		[5]	—	1	Reserved																																
22	16	[4:0]	SHP rising	5	SHP rising edge																																
		[5]	—	1	Reserved																																
23	17	[4:0]	SHD falling	5	SHD falling edge	Step is twos complement of data. 1 step = (1 pixel clock term)/100.																															
		[5]	—	1	Reserved																																
24	18	[5:0]	SHD rising	5	SHD rising edge																																
		[0]	—	1	Reserved																																
ADCK delay	25	19	[5:0]	LSB	7	ADCK delay	Data[6:0] = 01Ah[0] × 26 + 019h[5:0]																														
							01Ah[0]	019h[5:0]	(DEC)	STEP																											
			1	00 0000b			(64)	Reserved																													
			—	—			—	—																													
			1	00 1101b			(77)	Reserved																													
			1	00 1110b			(78)	Reserved																													
			1	00 1111b			(79)	Reserved																													
			—	—			—	—																													
			1	11 1111b			(127)	-1																													
			0	00 0000b			(0)	0 (default)																													
			0	00 0001b			(default)	1																													
26	1A	[0]	MSB	←	0	—	—	48																													
					0	11 0001b	(48)	49																													
		0	11 0010b		(49)	Reserved																															
		—	—		—	—																															
		0	11 1111b		(63)	Reserved																															
						Step is twos complement of data. 1 step = (1 pixel clock term)/100.																															
					[5:1]	—	5	Reserved	Reserved Default = 0 (DEC)																												
		HG1/HG2	27		1B	[2:0]	DIV	3	High-speed pulse divide rate	000b = Divide by 16 (default) 001b = Divide by 2 — 111b = Divide by 14																											
						[3]	Enable	1	HG1A, HG2A, HG1B, HG2B, HL enable/standby	0 = Enabled (default) 1 = Standby																											
						[4]	HG1 POL	1	HG1A, HG1B, HL polarity during a TG standby condition	0 = High (default) 1 = Low																											
						[5]	—	1	Reserved	Reserved Default = 0																											

**Detailed TG Section (continued)**

SECTION	ADDRESS		PARAMETER			DESCRIPTION		UPDATE METHOD																		
	DEC	HEX	BITS	PARAMETER	# OF BITS	DESCRIPTION	VALUE																			
HG drive	28	1C	[1:0]	H current	2	H1, H2 output drive current	00b = Minimum 01b = Default (default) 10b = Mid-range 11b = Maximum	Real time																		
			[2]	HGB enable	1	HG1B, HG2B enable/disable	0 = Disabled (Z) (default) 1 = Enabled																			
			[5:3]	—	3	Reserved	Reserved Default = 011b																			
SHP/SHD PIX SKIP	29	1D	[2:0]	Ratio	3	RG, SHP, SHD pixel skipping ratio	<table border="1"> <thead> <tr> <th>DATA</th> <th>RATIO</th> </tr> </thead> <tbody> <tr><td>000b (default)</td><td>No skip</td></tr> <tr><td>001b</td><td>2 pixels</td></tr> <tr><td>010b</td><td>3 pixels</td></tr> <tr><td>011b</td><td>4 pixels</td></tr> <tr><td>100b</td><td>5 pixels</td></tr> <tr><td>101b</td><td>6 pixels</td></tr> <tr><td>110b</td><td>7 pixels</td></tr> <tr><td>111b</td><td>8 pixels</td></tr> </tbody> </table>	DATA	RATIO	000b (default)	No skip	001b	2 pixels	010b	3 pixels	011b	4 pixels	100b	5 pixels	101b	6 pixels	110b	7 pixels	111b	8 pixels	Real time
			DATA	RATIO																						
	000b (default)	No skip																								
	001b	2 pixels																								
	010b	3 pixels																								
	011b	4 pixels																								
100b	5 pixels																									
101b	6 pixels																									
110b	7 pixels																									
111b	8 pixels																									
[5:3]	Start	3	RG, SHP, SHD pixel skipping start point. Count from HD edge	Pixel number Default = 000b																						
—	30	1E	[0]	CLPDM	1	RG, SHP, SHD pixel skipping when CLPDM is active	0 = Continue 1 = Stop (default)	Real time																		
			[1]	CLPOB	1	RG, SHP, SHD pixel skipping when CLPOB is active	Reserved Default = 0000b																			
			[5:2]	—	4	Reserved	Reserved Default = 0000b																			
—	31	1F	[5:0]	—	6	Reserved	Reserved Default = 0 (DEC)	Real time																		
TG enable and sync	32	20	[0]	TG enable	1	TG function enable/disable	0 = TG function disabled (standby) (default) 1 = TG function enabled	Real time																		
			[1]	Master/slave	1	Master/slave mode	0 = Slave mode (HD, VD input) (default) 1 = Master mode (HD, VD output)																			
			[2]	VH, HD, MCK edge	1	VD, HD signal latch by MCK	0 = MCK rising edge (default) 1 = MCK falling edge																			
			[3]	VD, HD, TRG edge	1	VD, HD signal trigger	0 = Falling edge (default) 1 = Rising edge																			
			[4]	MCK detect	1	Detect MCK stop and set output default	0 = Disabled 1 = Enabled (default)																			
			[5]	—	1	Reserved	Reserved Default = 0																			
TRG	33	21	[0]	POL	1	Trigger polarity for TG CLK STOP (021h[1])	0 = Active high (default) 1 = Active low	Real time																		
			[1]	CLK stop	1	Trigger state (021h[0]) stops MCK for TG circuit (020h[4] does not work)	0 = Disabled (default) 1 = Enabled																			
			[2]	Frame INC	1	Trigger falling edge sets the frame (defined by 036h[5:3]) when this bit is enabled																				
			[3]	Counter RST	1	Trigger falling edge resets the line and pixel counter																				
			[4]	Frame RST	1	Trigger falling edge resets the frame counter when 021h[3] = 1																				
			[5]	—	1	Reserved			Reserved Default = 0																	

Detailed TG Section (continued)

SECTION	ADDRESS		PARAMETER			DESCRIPTION		UPDATE METHOD
	DEC	HEX	BITS	PARAMETER	# OF BITS	DESCRIPTION	VALUE	
Frame field	34	22	[0]	VD	1	Restart frame by VD	0 = Disabled 1 = Enabled (default)	Real time
			[1]	F <sub>LOAD</sub>	1	Restart frame by F <sub>LOAD</sub> of VA	0 = Disabled (default) 1 = Enabled	
			[2]	Frame, CNT, RST	1	Reset and start frame counter	0 = Disabled (default) 1 = Enabled	
			[3]	Field SET	1	Field setting selection	0 = VD/HD phase (default) 1 = Register setting	
			[4]	Field POL	1	Field polarity	0 = Low when ODD (default) 1 = High when EVEN	
			[5]	VD Even	1	VD edge trigger in EVEN field	0 = Disabled (default) 1 = Enabled	
Pin enable	35	23	[0]	V0N	1	Pin enable selection	0 = Disabled (default) 1 = Enabled	Real time
			[1]	V1N	1			
			[2]	V2N	1			
			[3]	V3N	1			
			[4]	V4N	1			
			[5]	V5N	1			
	36	24	[0]	V6N	1	Pin enable selection	0 = Disabled (default) 1 = Enabled	
			[1]	V7N	1			
			[2]	V8N	1			
			[3]	V9N	1			
			[4]	V10N	1			
			[5]	V11N	1			
	37	25	[0]	V12N	1	Pin enable selection	0 = Disabled (default) 1 = Enabled	
			[1]	—	1			
			[2]	—	1			
			[3]	P0	1			
			[4]	P1	1			
			[5]	P2	1			
	38	26	[0]	P3	1	Pin enable selection	0 = Disabled (default) 1 = Enabled	
			[1]	P4	1			
[2]			P5	1				
[3]			—	1				
[4]			—	1				
[5]			CLPDM	1				
39	27	[0]	CLPOB	1	Pin enable selection	0 = Disabled (default) 1 = Enabled		
		[1]	PBLK	1				
		[2]	HBLK	1				
		[3]	HDIV	1				
		[4]	VD	1				
		[5]	HD	1				
40	28	[0]	Field	1	Pin enable selection	0 = Disabled (default) 1 = Enabled		
		[1]	SUBN	1				
		[2]	Strobe	1				
		[3]	MSHUT	1				
		[4]	SUBSW1	1				
		[5]	SUBSW2	1				

**Detailed TG Section (continued)**

SECTION	ADDRESS		PARAMETER			DESCRIPTION		UPDATE METHOD
	DEC	HEX	BITS	PARAMETER	# OF BITS	DESCRIPTION	VALUE	
Pin initialization	41	29	[0]	V0N	1	Pin initialization polarity	0 = Low 1 = High (default)	VA initialization instruction
			[1]	V1N	1			
			[2]	V2N	1			
			[3]	V3N	1			
			[4]	V4N	1			
			[5]	V5N	1			
	42	2A	[0]	V6N	1			
			[1]	V7N	1			
			[2]	V8N	1			
			[3]	V9N	1			
			[4]	V10N	1			
			[5]	V11N	1			
	43	2B	[0]	V12N	1			
			[1]	—	1			
			[2]	—	1			
			[3]	P0	1			
			[4]	P1	1			
			[5]	P2	1			
	44	2C	[0]	P3	1			
			[1]	P4	1			
			[2]	P5	1			
			[3]	—	1			
			[4]	—	1			
			[5]	CLPDM	1			
	45	2D	[0]	CLPOB	1			
[1]			PBLK	1				
[2]			HBLK	1				
[3]			HDIV	1				
[4]			VD	1				
[5]			HD	1				
46	2E	[0]	Field	1				
		[1]	SUBN	1				
		[2]	Strobe	1				
		[3]	MSHUT	1				
		[4]	SUBSW1	1				
		[5]	SUBSW2	1				
ODD range	47	2F	[2:0]	ODD HD-VD	3	HD-VD delay for ODD detection	0-7 pixel delay Default = 001b	Real time
			[5:3]	ODD VD-HD	3	VD-HD delay for ODD detection	0-8 pixel delay Default = 001b	

Detailed TG Section (continued)

SECTION	ADDRESS		PARAMETER			DESCRIPTION		UPDATE METHOD															
	DEC	HEX	BITS	PARAMETER	# OF BITS	DESCRIPTION	VALUE																
V <sub>EVENT</sub> pin	48	30	[0]	V0N	1	Pin used for vertical event control	0 = Disabled (default) 1 = Enabled	Real time															
			[1]	V1N	1																		
			[2]	V2N	1																		
			[3]	V3N	1																		
			[4]	V4N	1																		
	49	31	[5]	V5N	1																		
			[0]	V6N	1																		
			[1]	V7N	1																		
			[2]	V8N	1																		
			[3]	V9N	1																		
50	32	[4]	V10N	1																			
		[5]	V11N	1																			
		[0]	V12N	1	Pin used for vertical event control	0 = Disabled (default) 1 = Enabled	Real time																
		[1]	—	1																			
		[2]	—	1																			
51	33	[5:3]	—	3	Reserved	Reserved Default = 000b																	
		[4:0]	TRG pin	5	Vertical event trigger pin	Terminal number. Refer to the <a href="#">Signal</a> section for details. Default = 0 (DEC)																	
Pixel counter	52	34	[5]	TRG edge	1	Vertical event trigger	0 = Rising edge (default) 1 = Falling edge																
			[3:0]	Pixel count	4	Pin counter start offset	Pixel number. Slave mode = 0110 (default) Master mode = 0	Real time															
Field	53	35	[5:4]	—	2	Reserved	Reserved Default = 00b																
			[0]	ODD/EVEN	1	Field index	0 = ODD (default) 1 = EVEN	Real time															
Frame	54	36	[5:1]	—	5	Reserved	Reserved Default = 0 (DEC)																
			[2:0]	Frame now	3	Set current frame number	Frame number. Default = 000b	VD or F <sub>LOAD</sub> (selected by 022h[1:0])															
			[5:3]	Frame TRG	3	Set frame number when trigger input	<table border="1"> <thead> <tr> <th>VA</th> <th>FRAME NUMBER</th> </tr> </thead> <tbody> <tr><td>VA1 (180h)</td><td>0</td></tr> <tr><td>VA2 (190h)</td><td>1</td></tr> <tr><td>VA3 (1A0h)</td><td>2</td></tr> <tr><td>VA4 (1B0h)</td><td>3</td></tr> <tr><td>VA5 (1C0h)</td><td>4</td></tr> <tr><td>VA6 (1D0h)</td><td>5</td></tr> <tr><td>VA7 (1E0h)</td><td>6</td></tr> <tr><td>VA8 (1F0h)</td><td>7</td></tr> </tbody> </table>		VA	FRAME NUMBER	VA1 (180h)	0	VA2 (190h)	1	VA3 (1A0h)	2	VA4 (1B0h)	3	VA5 (1C0h)	4	VA6 (1D0h)	5	VA7 (1E0h)
VA	FRAME NUMBER																						
VA1 (180h)	0																						
VA2 (190h)	1																						
VA3 (1A0h)	2																						
VA4 (1B0h)	3																						
VA5 (1C0h)	4																						
VA6 (1D0h)	5																						
VA7 (1E0h)	6																						
VA8 (1F0h)	7																						
V <sub>EVENT1</sub>	55	37	[5:0]	LSB	Start	12	Vertical event start 1	Event number Default = 0 (DEC)	Real time or R_Update (selected by 000h[3])														
			[5:0]	MSB																			
			[5:0]	LSB	Stop	12	Vertical event stop 1																
			[5:0]	MSB																			
V <sub>EVENT2</sub>	59	3B	[5:0]	LSB	Start	12	Vertical event start 2																
			[5:0]	MSB																			
			[5:0]	LSB	Stop	12	Vertical event stop 2																
			[5:0]	MSB																			
—	63	3F	[5:0]	—	6	Reserved	Reserved Default = 0 (DEC)	Real time or R_Update (selected by 000h[3])															



**Detailed TG Section (continued)**

SECTION	ADDRESS		PARAMETER			DESCRIPTION		UPDATE METHOD
	DEC	HEX	BITS	PARAMETER	# OF BITS	DESCRIPTION	VALUE	
MECH SHUT1	64	40	[5:0]	LSB	PIX	13	Mechanical shutter 1 toggling pix	Pixel number Default = 0 (DEC)
	65	41	[5:0]	MID				
	66	42	[0]	MSB				
			[5:1]	LSB	Line	12	Mechanical shutter 1 toggling line	Line number Default = 0 (DEC)
	67	43	[5:0]	MID				
	68	44	[0]	MSB				
			[5:1]	LSB	Frame	6	Mechanical shutter 1 toggling frame	Frame number Default = 0 (DEC)
	69	45	[0]	MSB				
			[1]	POL	1	Mechanical shutter 1 toggling polarity	0 = Low (default) 1 = High	
[5:2]	—	4	Reserved	Reserved Default = 0000b				
MECH SHUT2	70	46	[5:0]	LSB	PIX	13	Mechanical shutter 2 toggling pix	Pixel number Default = 0 (DEC)
	71	47	[5:0]	MID				
	72	48	[0]	MSB				
			[5:1]	LSB	Line	12	Mechanical shutter 2 toggling line	Line number Default = 0 (DEC)
	73	49	[5:0]	MID				
	74	4A	[0]	MSB				
			[5:1]	LSB	Frame	6	Mechanical shutter 2 toggling frame	Frame number Default = 0 (DEC)
	75	4B	[0]	MSB				
			[1]	POL	1	Mechanical shutter 2 toggling polarity	0 = Low (default) 1 = High	
[5:2]	—	4	Reserved	Reserved Default = 0000b				
Strobe 1	76	4C	[5:0]	LSB	PIX	13	Strobe 1 toggling pix	Pixel number Default = 0 (DEC)
	77	4D	[5:0]	MID				
	78	4E	[0]	MSB				
			[5:1]	LSB	Line	12	Strobe 1 toggling line	Line number Default = 0 (DEC)
	79	4F	[5:0]	MID				
	80	50	[0]	MSB				
			[5:1]	LSB	Frame	6	Strobe 1 toggling frame	Frame number Default = 0 (DEC)
	81	51	[0]	MSB				
			[1]	POL	1	Strobe 1 toggling polarity	0 = Low (default) 1 = High	
[5:2]	—	4	Reserved	Reserved Default = 0000b				
Strobe 2	82	52	[5:0]	LSB	PIX	13	Strobe 2 toggling pix	Pixel number Default = 0 (DEC)
	83	53	[5:0]	MID				
	84	54	[0]	MSB				
			[5:1]	LSB	Line	12	Strobe 2 toggling line	Line number Default = 0 (DEC)
	85	55	[5:0]	MID				
	86	56	[0]	MSB				
			[5:1]	LSB	Frame	6	Strobe 2 toggling frame	Frame number Default = 0 (DEC)
	87	57	[0]	MSB				
			[1]	POL	1	Strobe 2 toggling polarity	0 = Low (default) 1 = High	
[5:2]	—	4	Reserved	Reserved Default = 0000b				

Detailed TG Section (continued)

SECTION	ADDRESS		PARAMETER				DESCRIPTION		UPDATE METHOD
	DEC	HEX	BITS	PARAMETER	# OF BITS	DESCRIPTION	VALUE		
Strobe 3	88	58	[5:0]	LSB	PIX	13	Strobe 3 toggling pix	Pixel number Default = 0 (DEC)	Real time or R_Update (selected by 000h[3])
	89	59	[5:0]	MID					
	90	5A	[0]	MSB					
			[5:1]	LSB	Line	12	Strobe 3 toggling line	Line number Default = 0 (DEC)	
	91	5B	[5:0]	MID					
	92	5C	[0]	MSB					
			[5:1]	LSB	Frame	6	Strobe 3 toggling frame	Frame number Default = 0 (DEC)	
	93	5D	[0]	MSB					
[1]			POL	1	Strobe 3 toggling polarity	0 = Low (default) 1 = High			
[5:2]	—	4	Reserved	Reserved Default = 0000b					
Strobe 4	94	5E	[5:0]	LSB	PIX	13	Strobe 4 toggling pix	Pixel number Default = 0 (DEC)	Real time or R_Update (selected by 000h[3])
	95	5F	[5:0]	MID					
	96	60	[0]	MSB					
			[5:1]	LSB	Line	12	Strobe 4 toggling line	Line number Default = 0 (DEC)	
	97	61	[5:0]	MID					
	98	62	[0]	MSB					
			[5:1]	LSB	Frame	6	Strobe 4 toggling frame	Frame number Default = 0 (DEC)	
	99	63	[0]	MSB					
[1]			POL	1	Strobe 4 toggling polarity	0 = Low (default) 1 = High			
[5:2]	—	4	Reserved	Reserved Default = 0000b					
Strobe 5	100	64	[5:0]	LSB	PIX	13	Strobe 5 toggling pix	Pixel number Default = 0 (DEC)	Real time or R_Update (selected by 000h[3])
	101	65	[5:0]	MID					
	102	66	[0]	MSB					
			[5:1]	LSB	Line	12	Strobe 5 toggling line	Line number Default = 0 (DEC)	
	103	67	[5:0]	MID					
	104	68	[0]	MSB					
			[5:1]	LSB	Frame	6	Strobe 5 toggling frame	Frame number Default = 0 (DEC)	
	105	69	[0]	MSB					
[1]			POL	1	Strobe 5 toggling polarity	0 = Low (default) 1 = High			
[5:2]	—	4	Reserved	Reserved Default = 0000b					
Strobe 6	106	6A	[5:0]	LSB	PIX	13	Strobe 6 toggling pix	Pixel number Default = 0 (DEC)	Real time or R_Update (selected by 000h[3])
	107	6B	[5:0]	MID					
	108	6C	[0]	MSB					
			[5:1]	LSB	Line	12	Strobe 6 toggling line	Line number Default = 0 (DEC)	
	109	6D	[5:0]	MID					
	110	6E	[0]	MSB					
			[5:1]	LSB	Frame	6	Strobe 6 toggling frame	Frame number Default = 0 (DEC)	
	111	6F	[0]	MSB					
[1]			POL	1	Strobe 6 toggling polarity	0 = Low (default) 1 = High			
[5:2]	—	4	Reserved	Reserved Default = 0000b					

**Detailed TG Section (continued)**

SECTION	ADDRESS		PARAMETER			DESCRIPTION		UPDATE METHOD
	DEC	HEX	BITS	PARAMETER	# OF BITS	DESCRIPTION	VALUE	
Strobe 7	112	70	[5:0]	LSB	PIX	13	Strobe 7 toggling pix	Pixel number Default = 0 (DEC)
	113	71	[5:0]	MID				
	114	72	[0]	MSB	Line	12	Strobe 7 toggling line	Line number Default = 0 (DEC)
			[5:1]	LSB				
	115	73	[5:0]	MID	Frame	6	Strobe 7 toggling frame	Frame number Default = 0 (DEC)
	116	74	[0]	MSB				
			[5:1]	LSB				
	117	75	[0]	MSB	POL	1	Strobe 7 toggling polarity	0 = Low (default) 1 = High
[1]								
		[5:2]	—		4	Reserved	Reserved Default = 0000b	
Strobe 8	118	76	[5:0]	LSB	PIX	13	Strobe 8 toggling pix	Pixel number Default = 0 (DEC)
	119	77	[5:0]	MID				
	120	78	[0]	MSB	Line	12	Strobe 8 toggling line	Line number Default = 0 (DEC)
			[5:1]	LSB				
	121	79	[5:0]	MID	Frame	6	Strobe 8 toggling frame	Frame number Default = 0 (DEC)
	122	7A	[0]	MSB				
			[5:1]	LSB				
	123	7B	[0]	MSB	POL	1	Strobe 8 toggling polarity	0 = Low (default) 1 = High
[1]								
		[5:2]	—		4	Reserved	Reserved Default = 0000b	
SUBSW1-1	124	7C	[5:0]	LSB	Line	12	SUBSW1-1 toggling line	Line number Default = 0 (DEC)
	125	7D	[5:0]	MSB				
	126	7E	[5:0]		Frame	6	SUBSW1-1 toggling frame	Frame number Default = 0 (DEC)
	127	7F	[0]		POL	1	SUBSW1-1 polarity	0 = Low (default) 1 = High
[5:1]				—	5	Reserved	Reserved Default = 0 (DEC)	
SUBSW1-2	128	80	[5:0]	LSB	Line	12	SUBSW1-2 toggling line	Line number Default = 0 (DEC)
	129	81	[5:0]	MSB				
	130	82	[5:0]		Frame	6	SUBSW1-2 toggling frame	Frame number Default = 0 (DEC)
	131	83	[0]		POL	1	SUBSW1-2 polarity	0 = Low (default) 1 = High
[5:1]				—	5	Reserved	Reserved Default = 0 (DEC)	
SUBSW2-1	132	84	[5:0]	LSB	Line	12	SUBSW2-1 toggling line	Line number Default = 0 (DEC)
	133	85	[5:0]	MSB				
	134	86	[5:0]		Frame	6	SUBSW2-1 toggling frame	Frame number Default = 0 (DEC)
	135	87	[0]		POL	1	SUBSW2-1 polarity	0 = Low (default) 1 = High
[5:1]				—	5	Reserved	Reserved Default = 0 (DEC)	

Detailed TG Section (continued)

SECTION	ADDRESS		PARAMETER				DESCRIPTION		UPDATE METHOD
	DEC	HEX	BITS	PARAMETER	# OF BITS	DESCRIPTION	VALUE		
SUBSW2-2	136	88	[5:0]	LSB	Line	12	SUBSW2-2 toggling line	Line number Default = 0 (DEC)	Real time or R_Update (selected by 000h[3])
	137	89	[5:0]	MSB					
	138	8A	[5:0]	Frame		6	SUBSW2-2 toggling frame	Frame number Default = 0 (DEC)	
	139	8B	[0]	POL		1	SUBSW2-2 polarity	0 = Low (default) 1 = High	
[5:1]			—		5	Reserved	Reserved Default = 0 (DEC)		
SUBN 1	140	8C	[5:0]	LSB	PIX	13	SUBN 1 toggling pixel	Pixel number Default = 0 (DEC)	Real time or R_Update (selected by 000h[3])
	141	8D	[5:0]	MID					
	142	8E	[0]	MSB					
			[1]	POL		1	SUBN 1 polarity	0 = Low (default) 1 = High	
		[5:2]	—		4	Reserved	Reserved Default = 0000b		
		143	8F	[5:0]	LSB	PIX	13	SUBN 2 toggling pixel	Pixel number Default = 0 (DEC)
144	90	[5:0]	MID						
145	91	[0]	MSB						
		[1]	POL		1	SUBN 2 polarity	0 = Low (default) 1 = High		
		[5:2]	—		4	Reserved	Reserved Default = 0000b		
		146	92	[5:0]	LSB	PIX	13	SUBN 3 toggling pixel	Pixel number Default = 0 (DEC)
147	93	[5:0]	MID						
148	94	[0]	MSB						
		[1]	POL		1	SUBN 3 polarity	0 = Low (default) 1 = High		
		[5:2]	—		4	Reserved	Reserved Default = 0000b		
		149	95	[5:0]	LSB	PIX	13	SUBN 4 toggling pixel	Pixel number Default = 0 (DEC)
150	96	[5:0]	MID						
151	97	[0]	MSB						
		[1]	POL		1	SUBN 4 polarity	0 = Low (default) 1 = High		
		[5:2]	—		4	Reserved	Reserved Default = 0000b		
		152	98	[5:0]	LSB	Line	12	Electric shutter 1 toggling line	Line number Default = 0 (DEC)
153	99	[5:0]	MSB						
SUBN CHG 1	154	9A	[1:0]	Pattern		2	Electric shutter 1 SUBN pattern	Pattern number Default = 00b	
			[5:2]	—		4	Reserved	Reserved Default = 0000b	
SUBN CHG 2	155	9B	[5:0]	LSB	Line	12	Electric shutter 2 toggling line	Line number Default = 0 (DEC)	Real time or R_Update (selected by 000h[3])
	156	9C	[5:0]	MSB					
	157	9D	[1:0]	Pattern		2	Electric shutter 2 SUBN pattern	Pattern number Default = 00b	
			[5:2]	—		4	Reserved	Reserved Default = 0000b	
SUBN CHG 3	158	9E	[5:0]	LSB	Line	12	Electric shutter 3 toggling line	Line number Default = 0 (DEC)	Real time or R_Update (selected by 000h[3])
	159	9F	[5:0]	MSB					
	160	A0	[1:0]	Pattern		2	Electric shutter 3 SUBN pattern	Pattern number Default = 00b	
			[5:2]	—		4	Reserved	Reserved Default = 0000b	

**Detailed TG Section (continued)**

SECTION	ADDRESS		PARAMETER				DESCRIPTION		UPDATE METHOD
	DEC	HEX	BITS	PARAMETER	# OF BITS	DESCRIPTION	VALUE		
SUBN CHG 4	161	A1	[5:0]	LSB	Line	12	Electric shutter 4 toggling line	Line number Default = 0 (DEC)	Real time or R_Update (selected by 000h[3])
	162	A2	[5:0]	MSB					
	163	A3	[1:0]	Pattern	2	Electric shutter 4 SUBN pattern	Pattern number Default = 00b		
[5:2]			—	4	Reserved	Reserved Default = 0000b			
—	164	A4	[5:0]	—	6	Reserved	Reserved Default = 0 (DEC)	Real time or R_Update (selected by 000h[3])	
—	165	A5	[5:0]	—	6	Reserved	Reserved Default = 0 (DEC)		
—	166	A6	[5:0]	—	6	Reserved	Reserved Default = 0 (DEC)		
—	167	A7	[5:0]	—	6	Reserved	Reserved Default = 0 (DEC)		
—	168	A8	[5:0]	—	6	Reserved	Reserved Default = 0 (DEC)		
—	169	A9	[5:0]	—	6	Reserved	Reserved Default = 0 (DEC)		
—	170	AA	[5:0]	—	6	Reserved	Reserved Default = 0 (DEC)		
—	171	AB	[5:0]	—	6	Reserved	Reserved Default = 0 (DEC)		
—	172	AC	[5:0]	—	6	Reserved	Reserved Default = 0 (DEC)		
—	173	AD	[5:0]	—	6	Reserved	Reserved Default = 0 (DEC)		
—	174	AE	[5:0]	—	6	Reserved	Reserved Default = 0 (DEC)		
—	175	AF	[5:0]	—	6	Reserved	Reserved Default = 0 (DEC)		
—	176	B0	[5:0]	—	6	Reserved	Reserved Default = 0 (DEC)		
—	177	B1	[5:0]	—	6	Reserved	Reserved Default = 0 (DEC)		
—	178	B2	[5:0]	—	6	Reserved	Reserved Default = 0 (DEC)		
—	179	B3	[5:0]	—	6	Reserved	Reserved Default = 0 (DEC)		
—	180	B4	[5:0]	—	6	Reserved	Reserved Default = 0 (DEC)		

Detailed TG Section (continued)

SECTION	ADDRESS		PARAMETER			DESCRIPTION		UPDATE METHOD
	DEC	HEX	BITS	PARAMETER	# OF BITS	DESCRIPTION	VALUE	
Monitor pin select	181	B5	[3:0]	←	4	Monitor pin selection	1000b = TPP = SHP, TPD = SHD 1001b = TPP = CLPOB, TPD = CLPDM 1010b = TPP = PBLK, TPD = HDIV 1011b = TPP =HBLK, TPD = (na) Default = 0000b	Real time or R_Update (selected by 000h[3])
			[5:4]	—	2	Reserved	Reserved Default = 00b	
—	182	B6	[5:0]	—	6	Reserved	Reserved Default = 0 (DEC)	Real time or R_Update (selected by 000h[3])
—	183	B7	[5:0]	—	6	Reserved	Reserved Default = 0 (DEC)	
—	184	B8	[5:0]	—	6	Reserved	Reserved Default = 0 (DEC)	
—	185	B9	[5:0]	—	6	Reserved	Reserved Default = 0 (DEC)	
—	186	BA	[5:0]	—	6	Reserved	Reserved Default = 0 (DEC)	
—	187	BB	[5:0]	—	6	Reserved	Reserved Default = 0 (DEC)	
—	188	BC	[5:0]	—	6	Reserved	Reserved Default = 0 (DEC)	
—	189	BD	[5:0]	—	6	Reserved	Reserved Default = 0 (DEC)	
—	190	BE	[5:0]	—	6	Reserved	Reserved Default = 0 (DEC)	
—	191	BF	[5:0]	—	6	Reserved	Reserved Default = 0 (DEC)	

## PACKAGING INFORMATION

Orderable Device	Status (1)	Package Type	Package Drawing	Pins	Package Qty	Eco Plan (2)	Lead/Ball Finish	MSL Peak Temp (3)	Op Temp (°C)	Top-Side Markings (4)	Samples
VSP01M01ZWD	OBSOLETE	NFBGA	ZWD	100		TBD	Call TI	Call TI	0 to 85	VSP01M01	
VSP01M01ZWDR	ACTIVE	NFBGA	ZWD	100	1000	Pb-Free (RoHS)	SNAGCU	Level-2-260C-1 YEAR	0 to 85	VSP01M01	<b>Samples</b>

(1) The marketing status values are defined as follows:

**ACTIVE:** Product device recommended for new designs.

**LIFEBUY:** TI has announced that the device will be discontinued, and a lifetime-buy period is in effect.

**NRND:** Not recommended for new designs. Device is in production to support existing customers, but TI does not recommend using this part in a new design.

**PREVIEW:** Device has been announced but is not in production. Samples may or may not be available.

**OBSOLETE:** TI has discontinued the production of the device.

(2) Eco Plan - The planned eco-friendly classification: Pb-Free (RoHS), Pb-Free (RoHS Exempt), or Green (RoHS & no Sb/Br) - please check <http://www.ti.com/productcontent> for the latest availability information and additional product content details.

**TBD:** The Pb-Free/Green conversion plan has not been defined.

**Pb-Free (RoHS):** TI's terms "Lead-Free" or "Pb-Free" mean semiconductor products that are compatible with the current RoHS requirements for all 6 substances, including the requirement that lead not exceed 0.1% by weight in homogeneous materials. Where designed to be soldered at high temperatures, TI Pb-Free products are suitable for use in specified lead-free processes.

**Pb-Free (RoHS Exempt):** This component has a RoHS exemption for either 1) lead-based flip-chip solder bumps used between the die and package, or 2) lead-based die adhesive used between the die and leadframe. The component is otherwise considered Pb-Free (RoHS compatible) as defined above.

**Green (RoHS & no Sb/Br):** TI defines "Green" to mean Pb-Free (RoHS compatible), and free of Bromine (Br) and Antimony (Sb) based flame retardants (Br or Sb do not exceed 0.1% by weight in homogeneous material)

(3) MSL, Peak Temp. -- The Moisture Sensitivity Level rating according to the JEDEC industry standard classifications, and peak solder temperature.

(4) Only one of markings shown within the brackets will appear on the physical device.

**Important Information and Disclaimer:** The information provided on this page represents TI's knowledge and belief as of the date that it is provided. TI bases its knowledge and belief on information provided by third parties, and makes no representation or warranty as to the accuracy of such information. Efforts are underway to better integrate information from third parties. TI has taken and continues to take reasonable steps to provide representative and accurate information but may not have conducted destructive testing or chemical analysis on incoming materials and chemicals. TI and TI suppliers consider certain information to be proprietary, and thus CAS numbers and other limited information may not be available for release.

In no event shall TI's liability arising out of such information exceed the total purchase price of the TI part(s) at issue in this document sold by TI to Customer on an annual basis.

**TAPE AND REEL INFORMATION**
**REEL DIMENSIONS**

**TAPE DIMENSIONS**

A0	Dimension designed to accommodate the component width
B0	Dimension designed to accommodate the component length
K0	Dimension designed to accommodate the component thickness
W	Overall width of the carrier tape
P1	Pitch between successive cavity centers

**TAPE AND REEL INFORMATION**

\*All dimensions are nominal

Device	Package Type	Package Drawing	Pins	SPQ	Reel Diameter (mm)	Reel Width W1 (mm)	A0 (mm)	B0 (mm)	K0 (mm)	P1 (mm)	W (mm)	Pin1 Quadrant
VSP01M01ZWDR	NFBGA	ZWD	100	1000	330.0	16.4	7.3	7.3	2.2	12.0	16.0	Q1



TAPE AND REEL BOX DIMENSIONS



\*All dimensions are nominal

Device	Package Type	Package Drawing	Pins	SPQ	Length (mm)	Width (mm)	Height (mm)
VSP01M01ZWDR	NFBGA	ZWD	100	1000	342.0	336.0	34.0

ZWD (S-PBGA-N100)

PLASTIC BALL GRID ARRAY

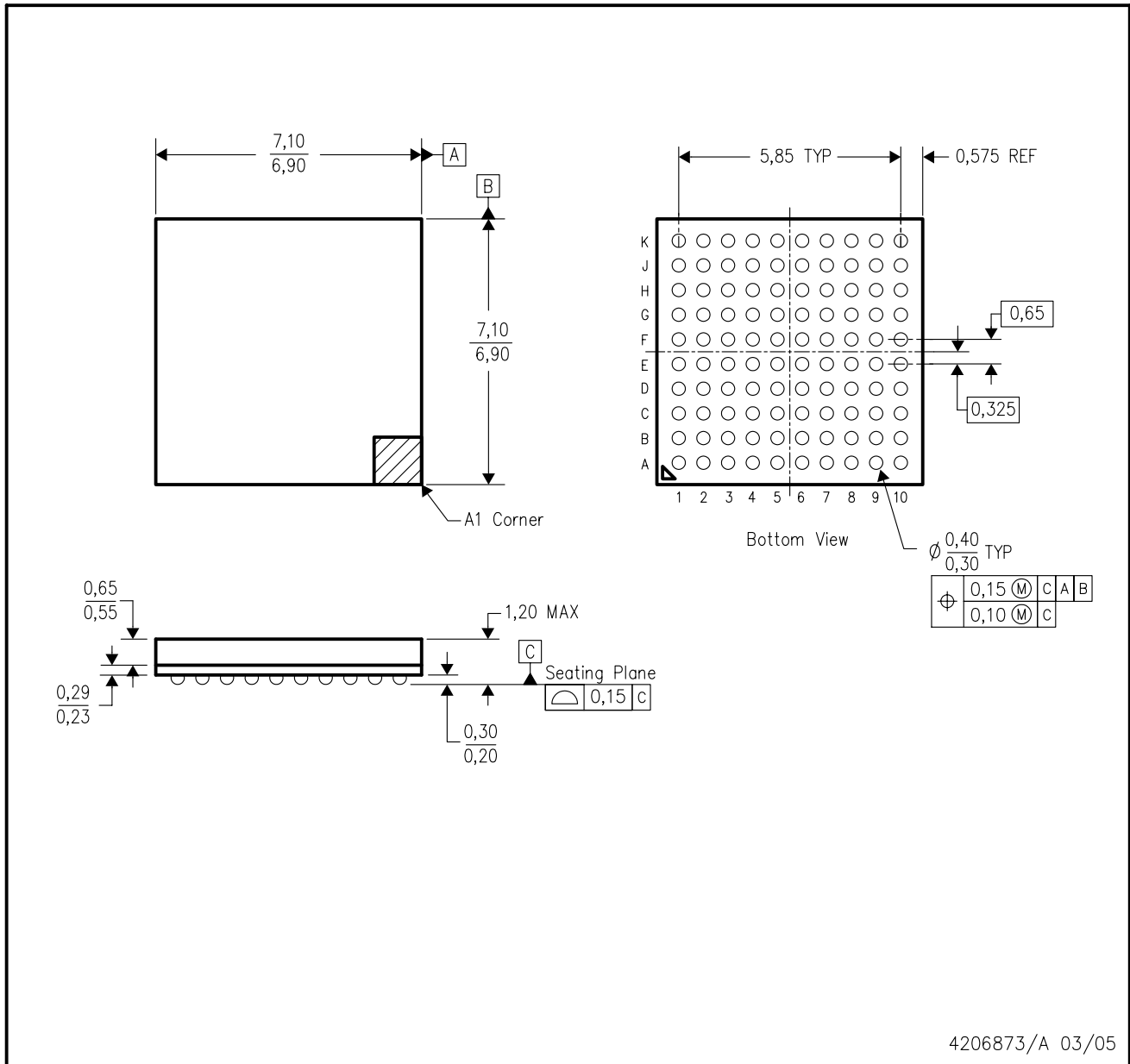

- NOTES:
- A. All linear dimensions are in millimeters.
  - B. This drawing is subject to change without notice.
  - C. This package is lead-free.

## IMPORTANT NOTICE

Texas Instruments Incorporated and its subsidiaries (TI) reserve the right to make corrections, enhancements, improvements and other changes to its semiconductor products and services per JESD46, latest issue, and to discontinue any product or service per JESD48, latest issue. Buyers should obtain the latest relevant information before placing orders and should verify that such information is current and complete. All semiconductor products (also referred to herein as "components") are sold subject to TI's terms and conditions of sale supplied at the time of order acknowledgment.

TI warrants performance of its components to the specifications applicable at the time of sale, in accordance with the warranty in TI's terms and conditions of sale of semiconductor products. Testing and other quality control techniques are used to the extent TI deems necessary to support this warranty. Except where mandated by applicable law, testing of all parameters of each component is not necessarily performed.

TI assumes no liability for applications assistance or the design of Buyers' products. Buyers are responsible for their products and applications using TI components. To minimize the risks associated with Buyers' products and applications, Buyers should provide adequate design and operating safeguards.

TI does not warrant or represent that any license, either express or implied, is granted under any patent right, copyright, mask work right, or other intellectual property right relating to any combination, machine, or process in which TI components or services are used. Information published by TI regarding third-party products or services does not constitute a license to use such products or services or a warranty or endorsement thereof. Use of such information may require a license from a third party under the patents or other intellectual property of the third party, or a license from TI under the patents or other intellectual property of TI.

Reproduction of significant portions of TI information in TI data books or data sheets is permissible only if reproduction is without alteration and is accompanied by all associated warranties, conditions, limitations, and notices. TI is not responsible or liable for such altered documentation. Information of third parties may be subject to additional restrictions.

Resale of TI components or services with statements different from or beyond the parameters stated by TI for that component or service voids all express and any implied warranties for the associated TI component or service and is an unfair and deceptive business practice. TI is not responsible or liable for any such statements.

Buyer acknowledges and agrees that it is solely responsible for compliance with all legal, regulatory and safety-related requirements concerning its products, and any use of TI components in its applications, notwithstanding any applications-related information or support that may be provided by TI. Buyer represents and agrees that it has all the necessary expertise to create and implement safeguards which anticipate dangerous consequences of failures, monitor failures and their consequences, lessen the likelihood of failures that might cause harm and take appropriate remedial actions. Buyer will fully indemnify TI and its representatives against any damages arising out of the use of any TI components in safety-critical applications.

In some cases, TI components may be promoted specifically to facilitate safety-related applications. With such components, TI's goal is to help enable customers to design and create their own end-product solutions that meet applicable functional safety standards and requirements. Nonetheless, such components are subject to these terms.

No TI components are authorized for use in FDA Class III (or similar life-critical medical equipment) unless authorized officers of the parties have executed a special agreement specifically governing such use.

Only those TI components which TI has specifically designated as military grade or "enhanced plastic" are designed and intended for use in military/aerospace applications or environments. Buyer acknowledges and agrees that any military or aerospace use of TI components which have **not** been so designated is solely at the Buyer's risk, and that Buyer is solely responsible for compliance with all legal and regulatory requirements in connection with such use.

TI has specifically designated certain components as meeting ISO/TS16949 requirements, mainly for automotive use. In any case of use of non-designated products, TI will not be responsible for any failure to meet ISO/TS16949.

### Products

Audio	<a href="http://www.ti.com/audio">www.ti.com/audio</a>
Amplifiers	<a href="http://amplifier.ti.com">amplifier.ti.com</a>
Data Converters	<a href="http://dataconverter.ti.com">dataconverter.ti.com</a>
DLP® Products	<a href="http://www.dlp.com">www.dlp.com</a>
DSP	<a href="http://dsp.ti.com">dsp.ti.com</a>
Clocks and Timers	<a href="http://www.ti.com/clocks">www.ti.com/clocks</a>
Interface	<a href="http://interface.ti.com">interface.ti.com</a>
Logic	<a href="http://logic.ti.com">logic.ti.com</a>
Power Mgmt	<a href="http://power.ti.com">power.ti.com</a>
Microcontrollers	<a href="http://microcontroller.ti.com">microcontroller.ti.com</a>
RFID	<a href="http://www.ti-rfid.com">www.ti-rfid.com</a>
OMAP Applications Processors	<a href="http://www.ti.com/omap">www.ti.com/omap</a>
Wireless Connectivity	<a href="http://www.ti.com/wirelessconnectivity">www.ti.com/wirelessconnectivity</a>

### Applications

Automotive and Transportation	<a href="http://www.ti.com/automotive">www.ti.com/automotive</a>
Communications and Telecom	<a href="http://www.ti.com/communications">www.ti.com/communications</a>
Computers and Peripherals	<a href="http://www.ti.com/computers">www.ti.com/computers</a>
Consumer Electronics	<a href="http://www.ti.com/consumer-apps">www.ti.com/consumer-apps</a>
Energy and Lighting	<a href="http://www.ti.com/energy">www.ti.com/energy</a>
Industrial	<a href="http://www.ti.com/industrial">www.ti.com/industrial</a>
Medical	<a href="http://www.ti.com/medical">www.ti.com/medical</a>
Security	<a href="http://www.ti.com/security">www.ti.com/security</a>
Space, Avionics and Defense	<a href="http://www.ti.com/space-avionics-defense">www.ti.com/space-avionics-defense</a>
Video and Imaging	<a href="http://www.ti.com/video">www.ti.com/video</a>

### TI E2E Community

[e2e.ti.com](http://e2e.ti.com)