

DIRECT RAMBUS™ CLOCK GENERATOR

FEATURES

- 533-MHz Differential Clock Source for Direct Rambus™ Memory Systems for an 1066-MHz Data Transfer Rate
- Fail-Safe Power Up Initialization
- Synchronizes the Clock Domains of the Rambus Channel With an External System or Processor Clock
- Three Power Operating Modes to Minimize Power for Mobile and Other Power-Sensitive Applications
- Operates From a Single 3.3-V Supply and 120 mW at 300 MHz (Typ)
- Packaged in a Shrink Small-Outline Package (DBQ)
- Supports Frequency Multipliers: 4, 6, 8, 16/3
- No External Components Required for PLL
- Supports Independent Channel Clocking
- Spread Spectrum Clocking Tracking Capability to Reduce EMI
- Designed for Use With TI's 133-MHz Clock Synthesizers CDC924 and CDC921
- Cycle-Cycle Jitter Is Less Than 40 ps at 533 MHz
- Certified by Gigatest Labs to Exceed the Rambus DRCG Validation Requirement
- Supports Industrial Temperature Range of –40°C to 85°C

DBQ PACKAGE
(TOP VIEW)

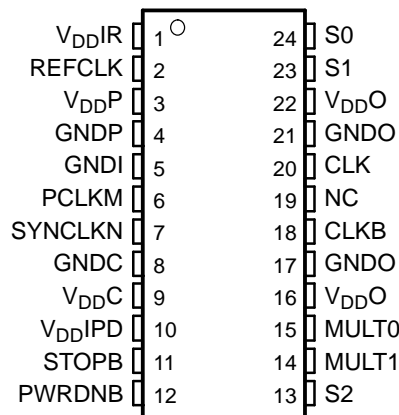

NC – No internal connection

DESCRIPTION

The Direct Rambus clock generator (DRCG) provides the necessary clock signals to support a Direct Rambus memory subsystem. It includes signals to synchronize the Direct Rambus channel clock to an external system or processor clock. It is designed to support Direct Rambus memory on a desktop, workstation, server, and mobile PC motherboards. DRCG also provides an off-the-shelf solution for a broad range of Direct Rambus memory applications.

The DRCG provides clock multiplication and phase alignment for a Direct Rambus memory subsystem to enable synchronous communication between the Rambus channel and ASIC clock domains. In a Direct Rambus memory subsystem, a system clock source provides the REFCLK and PCLK clock references to the DRCG and memory controller, respectively. The DRCG multiplies REFCLK and drives a high-speed BUSCLK to RDRAMs and the memory controller. Gear ratio logic in the memory controller divides the PCLK and BUSCLK frequencies by ratios M and N such that PCLKM = SYNCLKN, where SYNCLK = BUSCLK/4. The DRCG detects the phase difference between PCLKM and SYNCLKN and adjusts the phase of BUSCLK such that the skew between PCLKM and SYNCLKN is minimized. This allows data to be transferred across the SYNCLK/PCLK boundary without incurring additional latency.



Please be aware that an important notice concerning availability, standard warranty, and use in critical applications of Texas Instruments semiconductor products and disclaimers thereto appears at the end of this data sheet.

DIRECT RAMBUS, Rambus are trademarks of Rambus Inc.

User control is provided by multiply and mode selection terminals. The multiply terminals provide selection of one of four clock frequency multiply ratios, generating BUSCLK frequencies ranging from 267 MHz to 533 MHz with clock references ranging from 33 MHz to 100 MHz. The mode select terminals can be used to select a bypass mode where the frequency multiplied reference clock is directly output to the Rambus channel for systems where synchronization between the Rambus clock and a system clock is not required. Test modes are provided to bypass the PLL and output REFCLK on the Rambus channel and to place the outputs in a high-impedance state for board testing.

The CDCFR83A has a fail-safe power up initialization state-machine which supports proper operation under all power up conditions.

The CDCFR83A is characterized for operation over free-air temperatures of -40°C to 85°C .

FUNCTIONAL BLOCK DIAGRAM

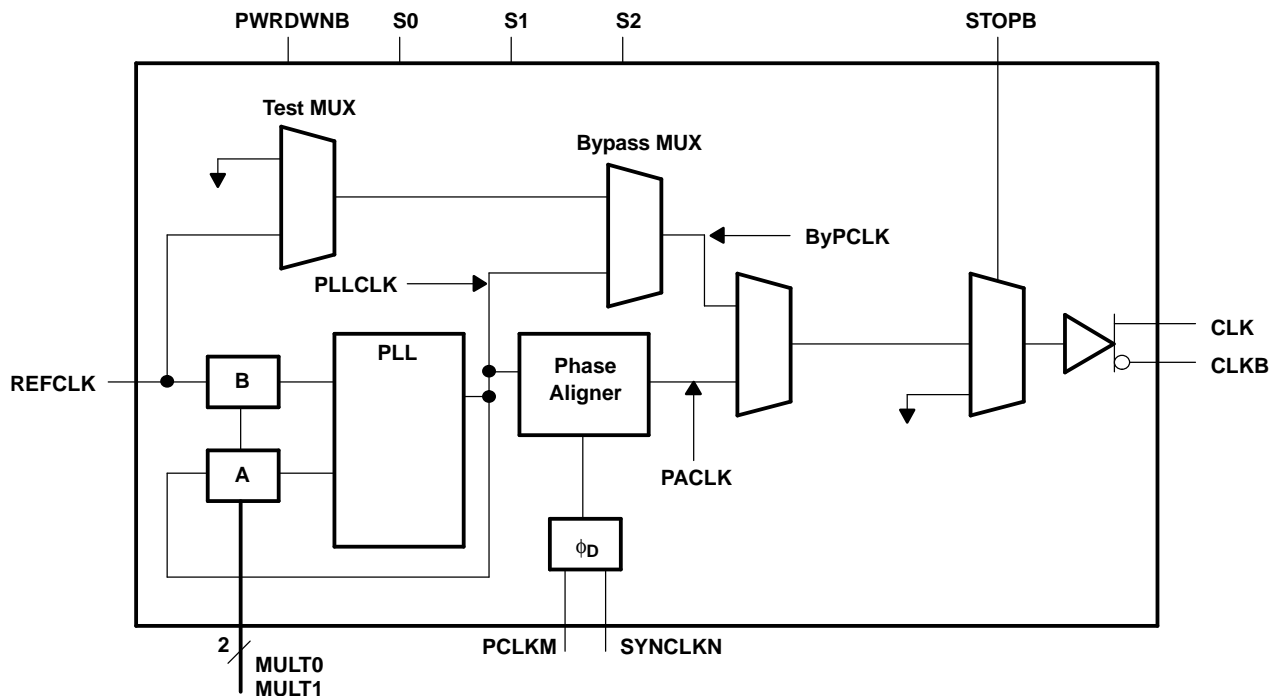

FUNCTION TABLE⁽¹⁾

MODE	S0	S1	S2	CLK	CLKB
Normal	0	0	0	Phase aligned clock	Phase aligned clock B
Bypass	1	0	0	PLLCLK	PLLCLKB
Test	1	1	0	REFCLK	REFCLKB
Output test (OE)	0	1	x	Hi-Z	Hi-Z
Reserved	0	0	1	–	–
Reserved	1	0	1	–	–
Reserved	1	1	1	Hi-Z	Hi-Z

(1) X = don't care, Hi-Z = high impedance

TERMINAL FUNCTIONS

TERMINAL		I/O	DESCRIPTION
NAME	NO.		
CLK	20	O	Output clock
CLKB	18	O	Output clock (complement)
GNDC	8		GND for phase aligner
GNDI	5		GND for control inputs
GNDO	17, 21		GND for clock outputs
GNDP	4		GND for PLL
MULT0	15	I	PLL multiplier select
MULT1	14	I	PLL multiplier select
NC	19		Not used
PCLKM	6	I	Phase detector input
PWRDNB	12	I	Active low power down
REFCLK	2	I	Reference clock
S0	24	I	Mode control
S1	23	I	Mode control
S2	13	I	Mode control
STOPB	11	I	Active low output disable
SYNCLKN	7	I	Phase detector input
V _{DDC}	9		V _{DD} for phase aligner
V _{DDIPD}	10		Reference voltage for phase detector inputs and STOPB
V _{DDIR}	1		Reference voltage for REFCLK
V _{DDO}	16, 22		V _{DD} for clock outputs
V _{DDP}	3		V _{DD} for PLL

PLL DIVIDER SELECTION

Table 1 lists the supported REFCLK and BUSCLK frequencies. Other REFCLK frequencies are permitted, provided that (267 MHz < BUSCLK < 533 MHz) and (33 MHz < REFCLK < 100 MHz).

Table 1. REFCLK and BUSCLK Frequencies

MULT0	MULT1	REFCLK (MHz)	MULTIPLY RATIO	BUSCLK ⁽¹⁾ (MHz)
0	0	67	4	267
0	1	50	6	300
0	1	67	6	400
1	1	33	8	267
1	1	50	8	400
1	1	67	8	533
1	0	67	16/3	356

- (1) BUSCLK will be undefined until a valid reference clock is available at REFCLK. After applying REFCLK, the PLL requires stabilization time to achieve phase lock.

Table 2. Clock Output Driver States

STATE	PWRDNB	STOPB	CLK	CLKB
Powerdown	0	X	GND	GND
CLK stop	1	0	V_{X_STOP}	V_{X_STOP}
Normal	1	1	PACLK/PLLCLK/REFCLK ⁽¹⁾	PACLKB/PLLCLKB/REFCLKB

- (1) Depending on the state of S0, S1, and S2

ABSOLUTE MAXIMUM RATINGS

over operating free-air temperature range (unless otherwise noted)⁽¹⁾

	UNIT
V_{DD} Supply voltage range ⁽²⁾	–0.5 V to 4 V
V_O Output voltage range at any output terminal	–0.5 V to $V_{DD} + 0.5$ V
V_I Input voltage range at any input terminal	–0.5 V to $V_{DD} + 0.5$ V
Continuous total power dissipation	See Dissipation Rating Table
T_A Operating free-air temperature range	–40°C to 85°C
T_{stg} Storage temperature range	–65°C to 150°C
Lead temperature 1,6 mm (1/16 inch) from case for 10 seconds	260°C

- (1) Stresses beyond those listed under *absolute maximum ratings* may cause permanent damage to the device. These are stress ratings only, and functional operation of the device at these or any other conditions beyond those indicated under *recommended operating conditions* is not implied. Exposure to absolute-maximum-rated conditions for extended periods may affect device reliability.
 (2) All voltage values are with respect to the GND terminals.

DISSIPATION RATINGS

PACKAGE	$T_A \leq 25^\circ\text{C}$ POWER RATING	DERATING FACTOR ABOVE $T_A = 25^\circ\text{C}$ ⁽¹⁾	$T_A = 70^\circ\text{C}$ POWER RATING	$T_A = 85^\circ\text{C}$ POWER RATING
DBQ	1400 mW	11 mW/°C	905 mW	740 mW

- (1) This is the inverse of the junction-to-ambient thermal resistance when board-mounted and with no air flow.

RECOMMENDED OPERATING CONDITIONS

over operating free-air temperature range (unless otherwise noted)

		MIN	NOM	MAX	UNIT
V_{DD}	Supply voltage	3.135	3.3	3.465	V
V_{IH}	High-level input voltage (CMOS)	$0.7 \times V_{DD}$			V
V_{IL}	Low-level input voltage (CMOS)	$0.3 \times V_{DD}$			V
	Initial phase error at phase detector inputs (required range for phase aligner)	$-0.5 \times t_{c(PD)}$		$0.5 \times t_{c(PD)}$	V
V_{IL}	REFCLK low-level input voltage	$0.3 \times V_{DD}IR$			V
V_{IH}	REFCLK high-level input voltage	$0.7 \times V_{DD}IR$			V
V_{IL}	Input signal low voltage (STOPB)	$0.3 \times V_{DD}IPD$			V
V_{IH}	Input signal high voltage (STOPB)	$0.7 \times V_{DD}IPD$			V
	Input reference voltage for (REFCLK) ($V_{DD}IR$)	1.235		3.465	V
	Input reference voltage for (PCLKM and SYSCLKN) ($V_{DD}IPD$)	1.235		3.465	V
I_{OH}	High-level output current			-16	mA
I_{OL}	Low-level output current			16	mA
T_A	Operating free-air temperature	-40		85	°C

TIMING REQUIREMENTS

		MIN	MAX	UNIT
$t_{c(in)}$	Input cycle time	10	40	ns
	Input cycle-to-cycle jitter		250	ps
	Input duty cycle over 10,000 cycles	40%	60%	
f_{mod}	Input frequency modulation	30	33	kHz
	Modulation index, nonlinear maximum 0.5%		0.6%	
	Phase detector input cycle time (PCLKM and SYNCLKN)	30	100	ns
SR	Input slew rate	1	4	V/ns
	Input duty cycle (PCLKM and SYNCLKN)	25%	75%	

ELECTRICAL CHARACTERISTICS

over recommended operating free-air temperature range (unless otherwise noted)

PARAMETER		TEST CONDITIONS ⁽¹⁾	MIN	TYP ⁽²⁾	MAX	UNIT	
V _{O(STOP)}	Output voltage during CLK Stop (STOPB = 0)	See Figure 1	1.1		2		
V _{O(X)}	Output crossing-point voltage	See Figure 1 and Figure 6	1.3		1.8	V	
V _O	Output voltage swing	See Figure 1	0.4		0.6	V	
V _{IK}	Input clamp voltage	V _{DD} = 3.135 V, I _I = -18 mA			-1.2	V	
V _{OH}	High-level output voltage	See Figure 1			2	V	
		V _{DD} = min to max, I _{OH} = -1 mA	V _{DD} - 0.1				
		V _{DD} = 3.135 V, I _{OH} = -16 mA	2.4				
V _{OL}	Low-level output voltage	See Figure 1		1		V	
		V _{DD} = min to max, I _{OH} = 1 mA			0.1		
		V _{DD} = 3.135 V, I _{OH} = 16 mA			0.5		
I _{OH}	High-level output current	V _{DD} = 3.135 V, V _O = 1 V	-32	-52		mA	
		V _{DD} = 3.3 V, V _O = 1.65 V		-51			
		V _{DD} = 3.465 V, V _O = 3.135 V	-14.5	-21			
I _{OL}	Low-level output current	V _{DD} = 3.135 V, V _O = 1.95 V	43	61.5		mA	
		V _{DD} = 3.3 V, V _O = 1.65 V		65			
		V _{DD} = 3.465 V, V _O = 0.4 V		25.5	36		
I _{OZ}	High-impedance-state output current	S0 = 0, S1 = 1			±10	µA	
I _{OZ(STOP)}	High-impedance-state output current during CLK stop	Stop = 0, V _O = GND or V _{DD}			±100	µA	
I _{OZ(PD)}	High-impedance-state output current in power-down state	PWRDNB = 0, V _O = GND or V _{DD}	-10		100	µA	
I _{IH}	High-level input current	REFCLK, PCLKM, SYNCLKN, STOPB	V _{DD} = 3.465 V, V _I = V _{DD}		10	µA	
		PWRDNB, S0, S1, S2, MULT0, MULT1			10		
I _{IL}	Low-level input current	REFCLK, PCLKM, SYNCLKN, STOPB	V _{DD} = 3.465 V, V _I = 0		-10	µA	
		PWRDNB, S0, S1, S2, MULT0, MULT1			-10		
Z _O	Output impedance	High state	R _I at I _{O-} 14.5 mA to -16.5 mA	15	35	50	Ω
		Low state	R _I at I _O 14.5 mA to 16.5 mA	11	17	35	
	Reference current	V _{DD} IR, V _{DD} IPD	V _{DD} = 3.465 V	PWRDNB = 0		50	µA
				PWRDNB = 1		0.5	mA
C _I	Input capacitance	V _I = V _{DD} or GND		2		pF	
C _O	Output capacitance	V _O = V _{DD} or GND		3		pF	
I _{DD(PD)}	Supply current in power-down state	REFCLK = 0 MHz to 100 MHz, PWRDNB = 0, STOPB = 1			100	µA	
I _{DD(CLKSTOP)}	Supply current in CLK stop state	BUSCLK configured for 533 MHz			45	mA	
I _{DD(NORMAL)}	Supply current in normal state	BUSCLK = 533 MHz			100	mA	

(1) V_{DD} refers to any of the following; V_{DD}, V_{DD}IPD, V_{DD}IR, V_{DD}O, V_{DD}C, and V_{DD}P

(2) All typical values are at V_{DD} = 3.3 V, T_A = 25°C.

SWITCHING CHARACTERISTICS

over recommended operating free-air temperature range (unless otherwise noted)

PARAMETER		TEST CONDITIONS	MIN	TYP ⁽¹⁾	MAX	UNIT	
$t_{c(out)}$	Clock output cycle time		1.87		3.75	ns	
$t_{(jitter)}$	Total cycle jitter over 1, 2, 3, 4, 5, or 6 clock cycles	Infinite and stopped phase alignment	267 MHz	See Figure 3		80	ps
			300 MHz			70	
			356 MHz			60	
			400 MHz			50	
			533 MHz ⁽²⁾			40	
$t_{(phase)}$	Phase detector phase error for distributed loop	Static phase error ⁽³⁾	–100		100	ps	
$t_{(phase, SSC)}$	PLL output phase error when tracking SSC	Dynamic phase error ⁽³⁾	–100		100	ps	
$I_{(DC)}$	Output duty cycle over 10,000 cycles	See Figure 4	45%		55%		
$t_{(DC, err)}$	Output cycle-to-cycle duty cycle error	Infinite and stopped phase alignment	267 MHz	See Figure 5		80	ps
			300 MHz			70	
			356 MHz			60	
			400 MHz			50	
			533 MHz			50	
t_r, t_f	Output rise and fall times (measured at 20%–80% of output voltage)	See Figure 7	160		400	ps	
Δt	Difference between rise and fall times on a single device (20%–80%) $ t_f - t_r $	See Figure 7			100	ps	

(1) All typical values are at $V_{DD} = 3.3\text{ V}$, $T_A = 25^\circ\text{C}$.

(2) Jitter measurement according to Rambus validation specification

(3) Assured by design

STATE TRANSITION LATENCY SPECIFICATIONS

PARAMETER		FROM	TO	TEST CONDITIONS	MIN	TYP ⁽¹⁾	MAX	UNIT
$t_{(powerup)}$	Delay time, PWRDNB \uparrow to CLK/CLKB output settled (excluding $t_{(DISTLOCK)}$)	Powerdown	Normal	See Figure 8			3	ms
	Delay time, PWRDNB \uparrow to internal PLL and clock are on and settled						3	
$t_{(VDDpowerup)}$	Delay time, power up to CLK/CLKB output settled	V_{DD}	Normal	See Figure 8			3	ms
	Delay time, power up to internal PLL and clock are on and settled						3	
$t_{(MULT)}$	MULT0 and MULT1 change to CLK/CLKB output resettled (excluding $t_{(DISTLOCK)}$)	Normal	Normal	See Figure 9			1	ms
$t_{(CLKON)}$	STOPB \uparrow to CLK/CLKB glitch-free clock edges	CLK Stop	Normal	See Figure 10			10	ns
$t_{(CLKSETL)}$	STOPB \uparrow to CLK/CLKB output settled to within 50 ps of the phase before STOPB was disabled	CLK Stop	Normal	See Figure 10			20	cycles
$t_{(CLKOFF)}$	STOPB \downarrow to CLK/CLKB output disabled	Normal	CLK Stop	See Figure 10			5	ns
$t_{(powerdown)}$	Delay time, PWRDNB \downarrow to the device in the power-down mode	Normal	Powerdown	See Figure 8			1	ms
$t_{(STOP)}$	Maximum time in CLKSTOP (STOPB = 0) before reentering normal mode (STOPB = 1)	STOPB	Normal	See Figure 10			100	μs
$t_{(ON)}$	Minimum time in normal mode (STOPB = 1) before reentering CLKSTOP (STOPB = 0)	Normal	CLK Stop	See Figure 10	100			ms
$t_{(DISTLOCK)}$	Time from when CLK/CLKB output is settled to when the phase error between SYNCLKN and PCLKM falls within $t_{(phase)}$	Unlocked	Locked				5	ms

(1) All typical values are at $V_{DD} = 3.3\text{ V}$, $T_A = 25^\circ\text{C}$.

PARAMETER MEASUREMENT INFORMATION

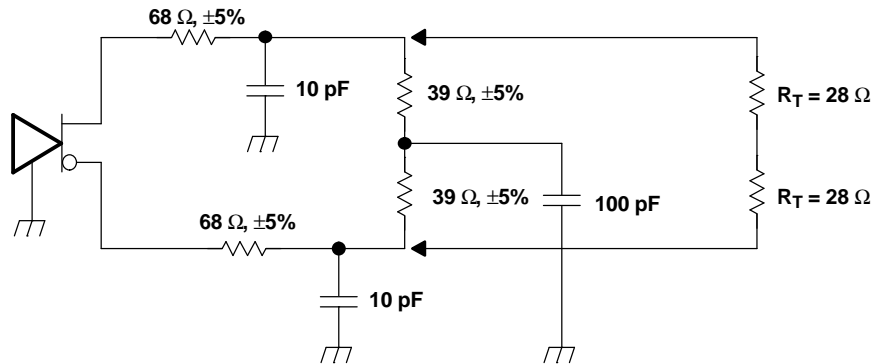
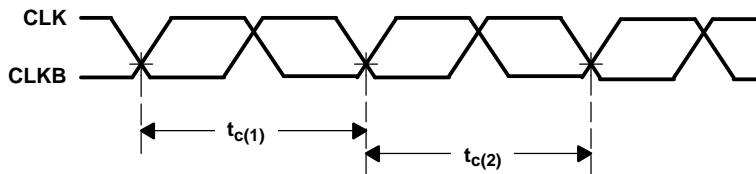
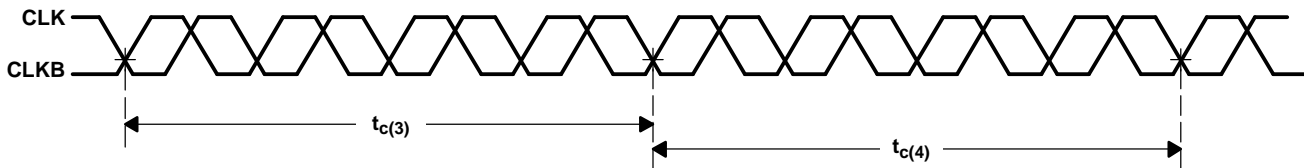

Figure 1. Test Load and Voltage Definitions ($V_{O(STOP)}$, $V_{O(X)}$, V_O , V_{OH} , V_{OL})



Cycle-to-cycle jitter = $|t_{c(1)} - t_{c(2)}|$ over 10000 consecutive cycles

Figure 2. Cycle-to-Cycle Jitter



Cycle-to-cycle jitter = $|t_{c(3)} - t_{c(4)}|$ over 10000 consecutive cycles

Figure 3. Short Term Cycle-to-Cycle Jitter Over Four Cycles

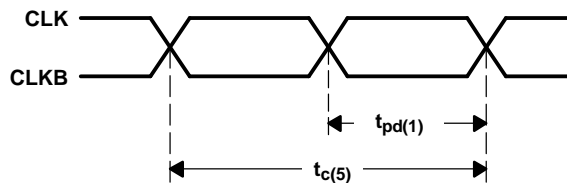

Duty cycle = $(t_{pd(1)}/t_{c(5)})$

Figure 4. Output Duty Cycle

PARAMETER MEASUREMENT INFORMATION (continued)

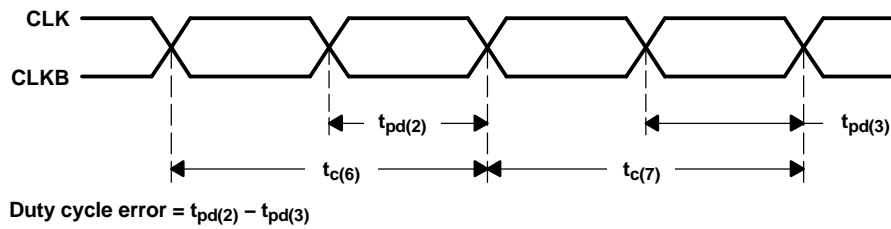

Figure 5. Duty Cycle Error (Cycle-to-Cycle)

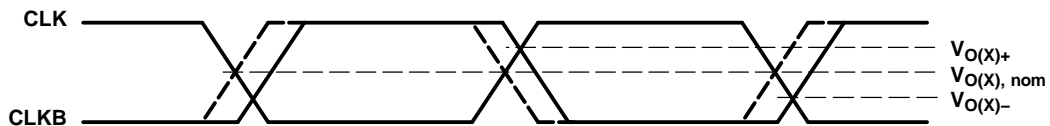

Figure 6. Crossing-Point Voltage



Figure 7. Voltage Waveforms

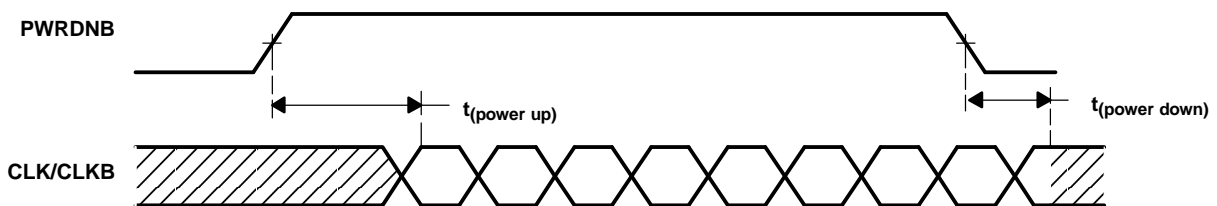

Figure 8. PWRDNB Transition Timings

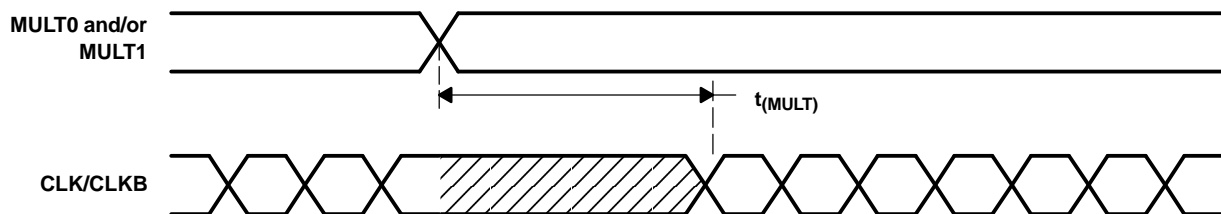
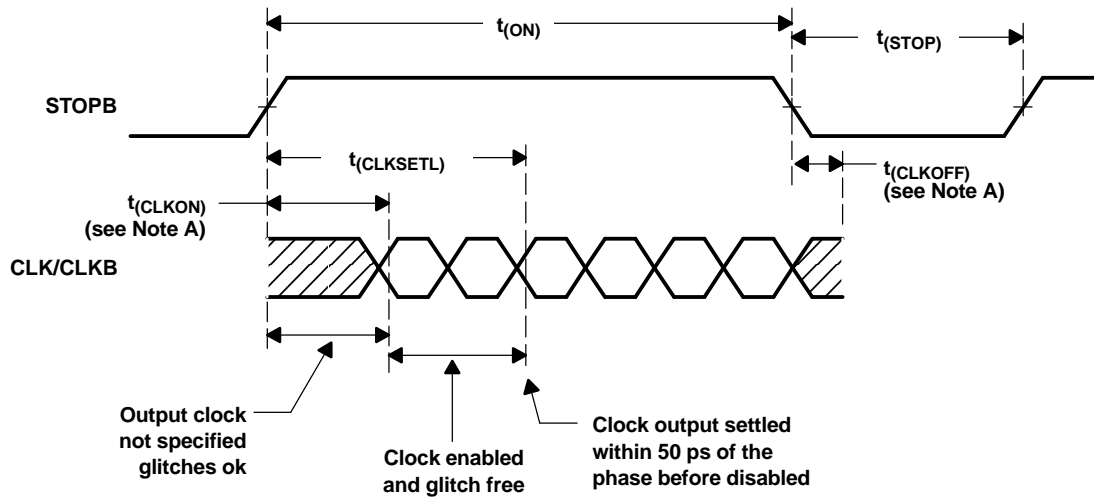

Figure 9. MULT Transition Timings

PARAMETER MEASUREMENT INFORMATION (continued)



A. $V_{ref} = V_O \pm 200 \text{ mV}$

Figure 10. STOPB Transition Timings

TAPE AND REEL INFORMATION
REEL DIMENSIONS

TAPE DIMENSIONS

A0	Dimension designed to accommodate the component width
B0	Dimension designed to accommodate the component length
K0	Dimension designed to accommodate the component thickness
W	Overall width of the carrier tape
P1	Pitch between successive cavity centers

TAPE AND REEL INFORMATION

*All dimensions are nominal

Device	Package Type	Package Drawing	Pins	SPQ	Reel Diameter (mm)	Reel Width W1 (mm)	A0 (mm)	B0 (mm)	K0 (mm)	P1 (mm)	W (mm)	Pin1 Quadrant
CDCFR83ADBQR	SSOP	DBQ	24	2500	330.0	16.4	6.5	9.0	2.1	8.0	16.0	Q1

TAPE AND REEL BOX DIMENSIONS



*All dimensions are nominal

Device	Package Type	Package Drawing	Pins	SPQ	Length (mm)	Width (mm)	Height (mm)
CDCFR83ADBQR	SSOP	DBQ	24	2500	367.0	367.0	38.0

DBQ (R-PDSO-G24)

PLASTIC SMALL-OUTLINE PACKAGE

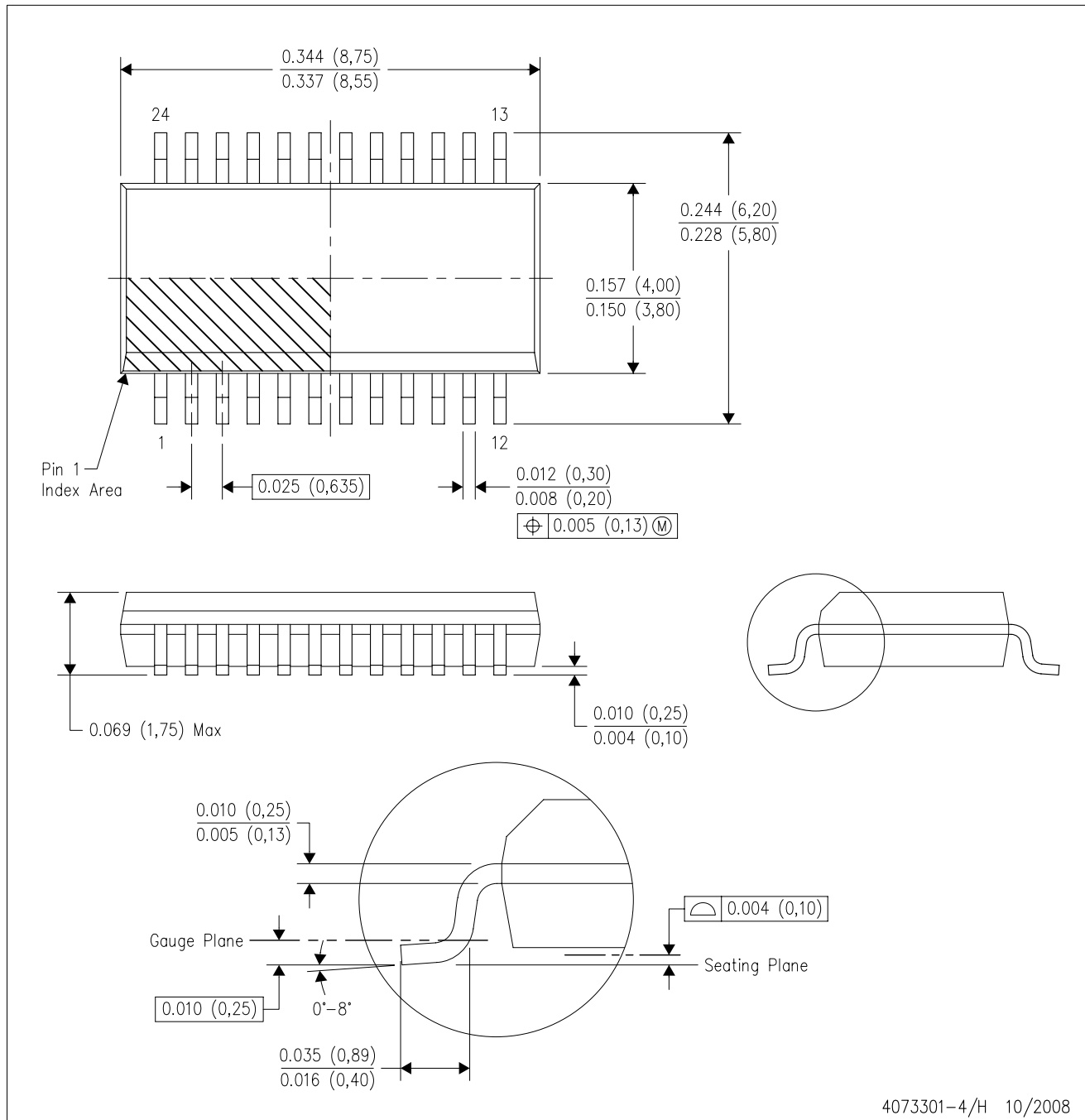

- NOTES:
- A. All linear dimensions are in inches (millimeters).
 - B. This drawing is subject to change without notice.
 - C. Body dimensions do not include mold flash or protrusion not to exceed 0.006 (0,15) per side.
 - D. Falls within JEDEC MO-137 variation AE.

DBQ (R-PDSO-G24)

PLASTIC SMALL OUTLINE PACKAGE

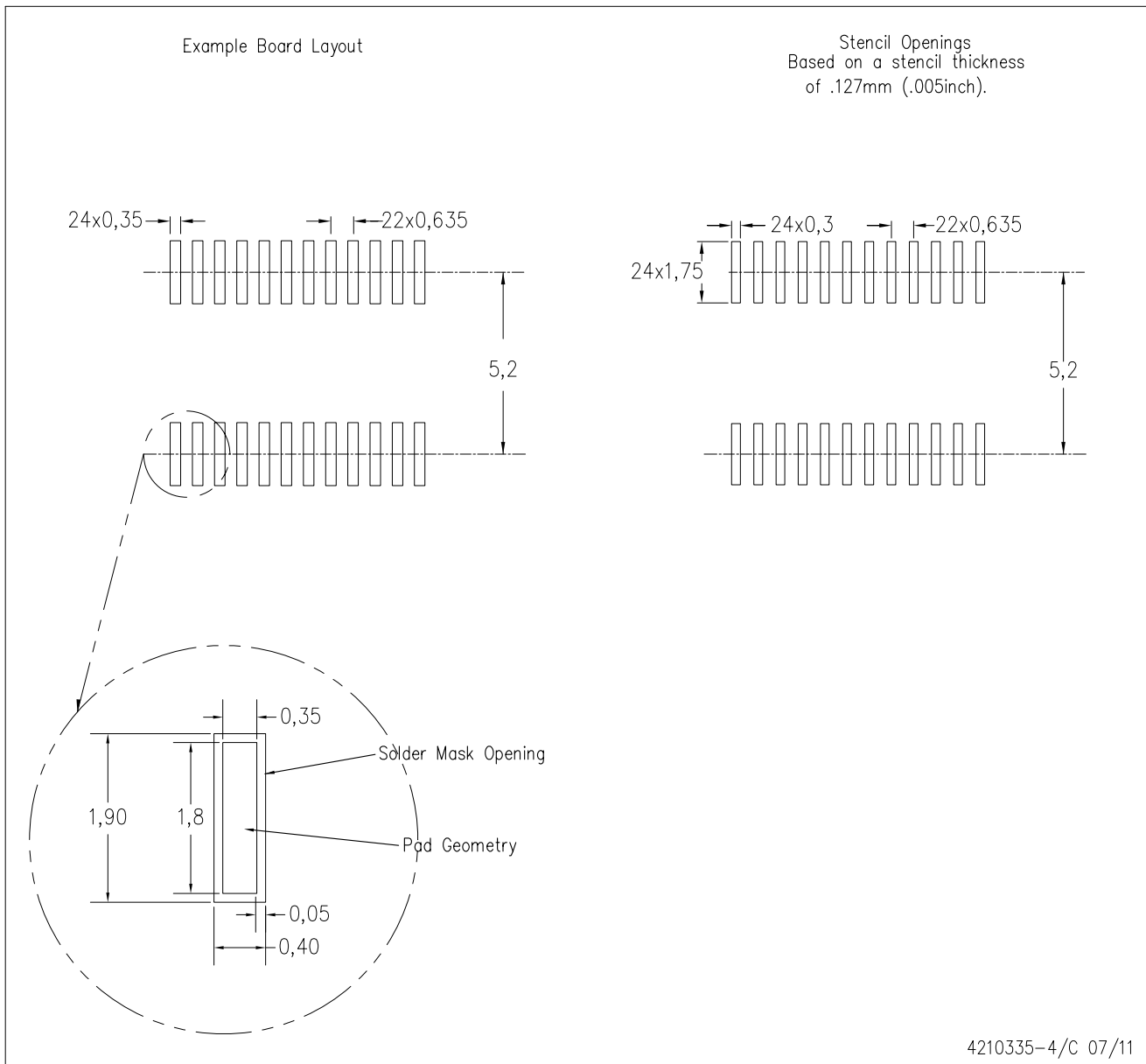

- NOTES:
- A. All linear dimensions are in millimeters.
 - B. This drawing is subject to change without notice.
 - C. Customers should place a note on the circuit board fabrication drawing not to alter the center solder mask defined pad.
 - D. Publication IPC-7351 is recommended for alternate designs.
 - E. Laser cutting apertures with trapezoidal walls and also rounding corners will offer better paste release. Customers should contact their board assembly site for stencil design recommendations. Example stencil design based on a 50% volumetric metal load solder paste. Refer to IPC-7525 for other stencil recommendations.

IMPORTANT NOTICE

Texas Instruments Incorporated and its subsidiaries (TI) reserve the right to make corrections, enhancements, improvements and other changes to its semiconductor products and services per JESD46C and to discontinue any product or service per JESD48B. Buyers should obtain the latest relevant information before placing orders and should verify that such information is current and complete. All semiconductor products (also referred to herein as "components") are sold subject to TI's terms and conditions of sale supplied at the time of order acknowledgment.

TI warrants performance of its components to the specifications applicable at the time of sale, in accordance with the warranty in TI's terms and conditions of sale of semiconductor products. Testing and other quality control techniques are used to the extent TI deems necessary to support this warranty. Except where mandated by applicable law, testing of all parameters of each component is not necessarily performed.

TI assumes no liability for applications assistance or the design of Buyers' products. Buyers are responsible for their products and applications using TI components. To minimize the risks associated with Buyers' products and applications, Buyers should provide adequate design and operating safeguards.

TI does not warrant or represent that any license, either express or implied, is granted under any patent right, copyright, mask work right, or other intellectual property right relating to any combination, machine, or process in which TI components or services are used. Information published by TI regarding third-party products or services does not constitute a license to use such products or services or a warranty or endorsement thereof. Use of such information may require a license from a third party under the patents or other intellectual property of the third party, or a license from TI under the patents or other intellectual property of TI.

Reproduction of significant portions of TI information in TI data books or data sheets is permissible only if reproduction is without alteration and is accompanied by all associated warranties, conditions, limitations, and notices. TI is not responsible or liable for such altered documentation. Information of third parties may be subject to additional restrictions.

Resale of TI components or services with statements different from or beyond the parameters stated by TI for that component or service voids all express and any implied warranties for the associated TI component or service and is an unfair and deceptive business practice. TI is not responsible or liable for any such statements.

Buyer acknowledges and agrees that it is solely responsible for compliance with all legal, regulatory and safety-related requirements concerning its products, and any use of TI components in its applications, notwithstanding any applications-related information or support that may be provided by TI. Buyer represents and agrees that it has all the necessary expertise to create and implement safeguards which anticipate dangerous consequences of failures, monitor failures and their consequences, lessen the likelihood of failures that might cause harm and take appropriate remedial actions. Buyer will fully indemnify TI and its representatives against any damages arising out of the use of any TI components in safety-critical applications.

In some cases, TI components may be promoted specifically to facilitate safety-related applications. With such components, TI's goal is to help enable customers to design and create their own end-product solutions that meet applicable functional safety standards and requirements. Nonetheless, such components are subject to these terms.

No TI components are authorized for use in FDA Class III (or similar life-critical medical equipment) unless authorized officers of the parties have executed a special agreement specifically governing such use.

Only those TI components which TI has specifically designated as military grade or "enhanced plastic" are designed and intended for use in military/aerospace applications or environments. Buyer acknowledges and agrees that any military or aerospace use of TI components which have **not** been so designated is solely at the Buyer's risk, and that Buyer is solely responsible for compliance with all legal and regulatory requirements in connection with such use.

TI has specifically designated certain components which meet ISO/TS16949 requirements, mainly for automotive use. Components which have not been so designated are neither designed nor intended for automotive use; and TI will not be responsible for any failure of such components to meet such requirements.

Products

Audio	www.ti.com/audio
Amplifiers	amplifier.ti.com
Data Converters	dataconverter.ti.com
DLP® Products	www.dlp.com
DSP	dsp.ti.com
Clocks and Timers	www.ti.com/clocks
Interface	interface.ti.com
Logic	logic.ti.com
Power Mgmt	power.ti.com
Microcontrollers	microcontroller.ti.com
RFID	www.ti-rfid.com
OMAP Mobile Processors	www.ti.com/omap
Wireless Connectivity	www.ti.com/wirelessconnectivity

Applications

Automotive and Transportation	www.ti.com/automotive
Communications and Telecom	www.ti.com/communications
Computers and Peripherals	www.ti.com/computers
Consumer Electronics	www.ti.com/consumer-apps
Energy and Lighting	www.ti.com/energy
Industrial	www.ti.com/industrial
Medical	www.ti.com/medical
Security	www.ti.com/security
Space, Avionics and Defense	www.ti.com/space-avionics-defense
Video and Imaging	www.ti.com/video

TI E2E Community e2e.ti.com