

## 1:4 Low Additive Jitter LVDS Buffer With Divider

Check for Samples: [CDCLVD1213](#)

### FEATURES

- 1:4 Differential Buffer
- Low Additive Jitter: <math><300\text{ fs RMS}</math> in 10-kHz to 20-MHz
- Low Output Skew of 20 ps (Max)
- Selectable Divider Ratio 1, /2, /4
- Universal Input Accepts LVDS, LVPECL, and CML
- 4 LVDS Outputs, ANSI EAI/TIA-644A Standard Compatible
- Clock Frequency up to 800 MHz
- 2.375 V–2.625 V Device Power Supply
- Industrial Temperature Range:  $-40^{\circ}\text{C}$  to  $85^{\circ}\text{C}$
- Packaged in 3 mm  $\times$  3 mm 16-Pin QFN (RGT)
- ESD Protection Exceeds 3 kV HBM, 1 kV CDM

### APPLICATIONS

- Telecommunications/Networking
- Medical Imaging
- Test and Measurement Equipment
- Wireless Communications
- General Purpose Clocking

### DESCRIPTION

The CDCLVD1213 clock buffer distributes an input clock to 4 pairs of differential LVDS clock outputs with low additive jitter for clock distribution. The input can either be LVDS, LVPECL, or CML.

The CDCLVD1213 contains a high performance divider for one output (QD) which can divide the input clock signal by a factor of 1, 2, or 4.

The CDCLVD1213 is specifically designed for driving  $50\ \Omega$  transmission lines. The part supports a fail safe function. The device incorporates an input hysteresis which prevents random oscillation of the outputs in the absence of an input signal.

The device operates in 2.5 V supply environment and is characterized from  $-40^{\circ}\text{C}$  to  $85^{\circ}\text{C}$  (ambient temperature). The CDCLVD1213 is packaged in small 16-pin, 3-mm  $\times$  3-mm QFN package.

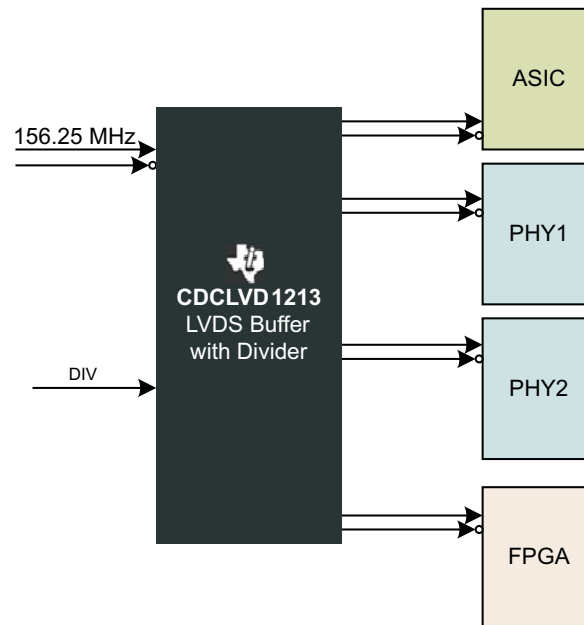

**Figure 1. Application Example**



Please be aware that an important notice concerning availability, standard warranty, and use in critical applications of Texas Instruments semiconductor products and disclaimers thereto appears at the end of this data sheet.



These devices have limited built-in ESD protection. The leads should be shorted together or the device placed in conductive foam during storage or handling to prevent electrostatic damage to the MOS gates.

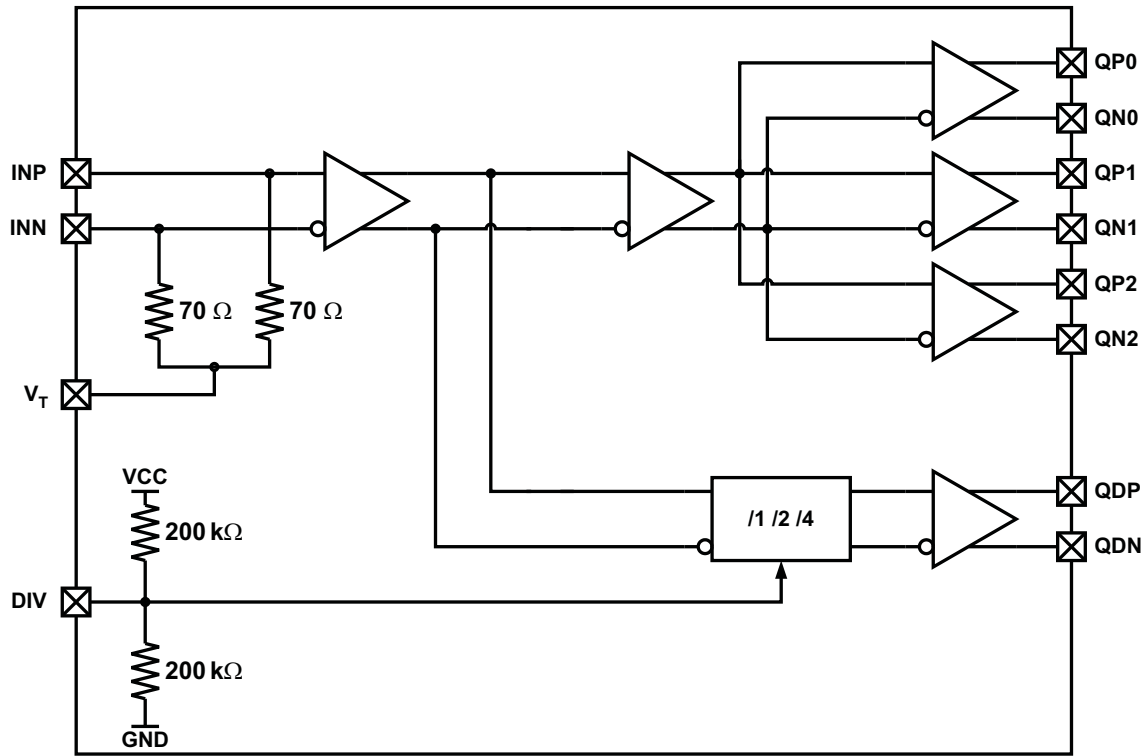
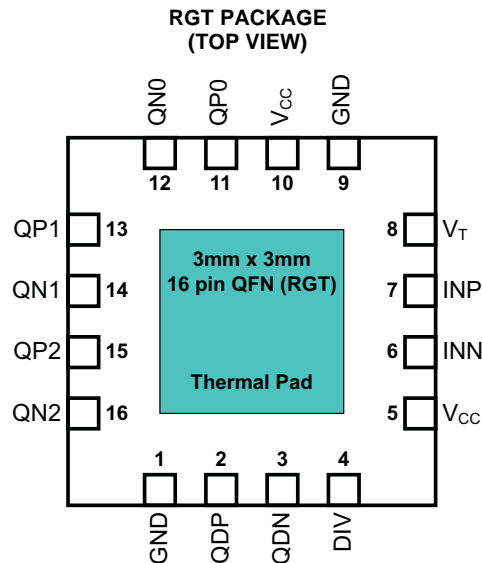

Figure 2. CDCLVD1213 Block Diagram



**PIN DESCRIPTIONS**
**CDCLVD1213 Pin Descriptions**

PIN		TYPE	DESCRIPTION
NAME	NO.		
V <sub>CC</sub>	5, 10	Power	2.5 V supply for the device
GND	1, 9	Ground	Device ground
INP, INN	7, 6	Input	Differential input pair
V <sub>T</sub>	8	Input	Input for threshold voltage
QDP, QDN	2,3	Output	Differential divided LVDS output pair
QP0, QN0	11,12	Output	Differential LVDS output pair no. 0
QP1, QN1	13,14	Output	Differential LVDS output pair no. 1
QP2, QN2	15,16	Output	Differential LVDS output pair no. 2
DIV	4	Input with an internal 200kΩ pull-up and pull-down	Divider selection – selects divider ratio for QD output; (See <a href="#">Table 1</a> )
Thermal Pad			See thermal management recommendations

**Table 1. Divider Selection Table**

DIV	DIVIDER RATIO
0	/1
open	/2
1	/4

**ABSOLUTE MAXIMUM RATINGS**

Over operating free-air temperature range (unless otherwise noted).<sup>(1)</sup>

	VALUE	UNIT
Supply voltage range, V <sub>CC</sub>	–0.3 to 2.8	V
Input voltage range, V <sub>I</sub>	–0.2 to V <sub>CC</sub> +0.2	V
Output voltage range, V <sub>O</sub>	–0.2 to V <sub>CC</sub> +0.2	V
Driver short circuit current , I <sub>OSD</sub>	See Note <sup>(2)</sup>	
Electrostatic discharge (Human Body Model 1.5 kΩ, 100 pF)	>3000	V

(1) Stresses beyond those listed under Absolute Maximum Ratings may cause permanent damage to the device. These are stress ratings only, and functional operation of the device at these or any other conditions beyond those indicated is not implied. Exposure to absolute-maximum-rated conditions for extended periods may affect device reliability.

(2) The output can handle the permanent short.

**RECOMMENDED OPERATING CONDITIONS**

Over operating free-air temperature range (unless otherwise noted).

	MIN	TYP	MAX	UNIT
Device supply voltage, V <sub>CC</sub>	2.375	2.5	2.625	V
Ambient temperature, T <sub>A</sub>	–40		85	°C

## THERMAL INFORMATION

THERMAL METRIC <sup>(1)</sup>		CDCLVD1213	UNITS
		RGT(16 PINS)	
$\theta_{JA}$	Junction-to-ambient thermal resistance	51.3	°C/W
$\theta_{JC(top)}$	Junction-to-case(top) thermal resistance	85.4	
$\theta_{JB}$	Junction-to-board thermal resistance	20.1	
$\psi_{JT}$	Junction-to-top characterization parameter	1.3	
$\psi_{JB}$	Junction-to-board characterization parameter	19.4	
$\theta_{JC(bottom)}$	Junction-to-case(bottom) thermal resistance	6	

(1) For more information about traditional and new thermal metrics, see the *IC Package Thermal Metrics* application report, [SPRA953](#).

## ELECTRICAL CHARACTERISTICS

At  $V_{CC} = 2.375\text{ V}$  to  $2.625\text{ V}$  and  $T_A = -40^\circ\text{C}$  to  $85^\circ\text{C}$  (unless otherwise noted).

PARAMETER	TEST CONDITIONS	MIN	TYP	MAX	UNIT
<b>DIVIDER CONTROL INPUT (DIV) CHARACTERISTICS</b>					
$V_{d3}$	3-State	Open	$0.5 \times V_{CC}$		V
$V_{dIH}$	Input high voltage	$0.7 \times V_{CC}$			V
$V_{dIL}$	Input low voltage			$0.2 \times V_{CC}$	V
$I_{dIH}$	Input high current	$V_{CC} = 2.625\text{ V}$ , $V_{IH} = 2.625\text{ V}$		30	$\mu\text{A}$
$I_{dIL}$	Input low current	$V_{CC} = 2.625\text{ V}$ , $V_{IL} = 0\text{ V}$		-30	$\mu\text{A}$
$R_{pull(DIV)}$	Input pull-up/ pull-down resistor		200		k $\Omega$
<b>DIFFERENTIAL INPUTS (INP, INN) CHARACTERISTICS</b>					
$f_{IN}$	Input frequency	Clock input		800	MHz
$V_{IN, DIFF}$	Differential input voltage peak-to-peak	$V_{ICM} = 1.25\text{ V}$	0.3	1.6	$V_{PP}$
$V_{ICM}$	Input common-mode voltage range		1	$V_{CC} - 0.3$	V
$R_{IN}$	Input termination	INP, INN to $V_T$ , DC	70		$\Omega$
$I_{IH}$	Input high current	$V_{CC} = 2.625\text{ V}$ , $V_{IH} = 2.625\text{ V}$		10	$\mu\text{A}$
$I_{IL}$	Input low current	$V_{CC} = 2.625\text{ V}$ , $V_{IL} = 0\text{ V}$		-10	$\mu\text{A}$
$\Delta V/\Delta T$	Input edge rate	20% to 80%	0.75		V/ns
$C_{IN}$	Input capacitance		2.5		pF

**ELECTRICAL CHARACTERISTICS (continued)**

At  $V_{CC} = 2.375\text{ V}$  to  $2.625\text{ V}$  and  $T_A = -40^\circ\text{C}$  to  $85^\circ\text{C}$  (unless otherwise noted).

PARAMETER		TEST CONDITIONS	MIN	TYP	MAX	UNIT
<b>LVDS OUTPUT CHARACTERISTICS</b>						
$ V_{OD} $	Differential output voltage magnitude	$V_{IN, DIFF, PP} = 0.3\text{ V}$ , $R_L = 100\ \Omega$	250		450	mV
$\Delta V_{OD}$	Change in differential output voltage magnitude		-15		15	mV
$V_{OC(SS)}$	Steady-state common mode output voltage		1.1		1.375	V
$\Delta V_{OC(SS)}$	Steady-state common mode output voltage	$V_{IN, DIFF, PP} = 0.6\text{ V}$ , $R_L = 100\ \Omega$	-15		15	mV
$I_{OS}$	Short-circuit output current	$V_{OD} = 0\text{ V}$			$\pm 24$	mA
$V_{OS}$	Output ac common mode	$V_{IN, DIFF, PP} = 0.6\text{ V}$ , $R_L = 100\ \Omega$		25	70	mV <sub>PP</sub>
$V_{ring}$	Output overshoot and undershoot	Percentage of output amplitude $V_{OD}$			10%	
$t_{PD}$	Propagation delay	$V_{IN, DIFF, PP} = 0.3\text{ V}$		1.5	2.5	ns
$t_{SK, PP}$	Part-to-part skew				600	ps
$t_{SK, O}$	Output skew <sup>(1)</sup>				20	ps
$t_{SK, P}$	Pulse skew (with 50% duty cycle input)	Crossing-point-to-crossing-point distortion	-50		50	ps
$t_{RJIT}$	Random additive jitter (with 50% duty cycle input)	Edge speed 0.75V/ns 10 kHz – 20 MHz			0.3	ps, RMS
$t_R/t_F$	Output rise/fall time	20% to 80%, 100 $\Omega$ , 5 pF	50		300	ps
$I_{CCSTAT}$	Static supply current	Outputs unterminated, $f = 0\text{ Hz}$		17	28	mA
$I_{CC100}$	Supply current	All outputs, $R_L = 100\ \Omega$ , $f = 100\text{ MHz}$		40	58	mA
$I_{CC800}$	Supply current	All outputs, $R_L = 100\ \Omega$ , $f = 800\text{ MHz}$		60	85	mA

(1) Undivided outputs only.

**Typical Additive Phase Noise Characteristics for 100 MHz Clock**

PARAMETER		MIN	TYP	MAX	UNIT
$phn_{100}$	Phase noise at 100 Hz offset		-132.9		dBc/Hz
$phn_{1k}$	Phase noise at 1 kHz offset		-138.8		dBc/Hz
$phn_{10k}$	Phase noise at 10 kHz offset		-147.4		dBc/Hz
$phn_{100k}$	Phase noise at 100 kHz offset		-153.6		dBc/Hz
$phn_{1M}$	Phase noise at 1 MHz offset		-155.2		dBc/Hz
$phn_{10M}$	Phase noise at 10 MHz offset		-156.2		dBc/Hz
$phn_{20M}$	Phase noise at 20 MHz offset		-156.6		dBc/Hz
$t_{RJIT}$	Random additive jitter from 10 kHz to 20 MHz		171		fs, RMS

**Typical Additive Phase Noise Characteristics for 737.27 MHz Clock**

PARAMETER		MIN	TYP	MAX	UNIT
$phn_{100}$	Phase noise at 100 Hz offset		-80.2		dBc/Hz
$phn_{1k}$	Phase noise at 1 kHz offset		-114.3		dBc/Hz
$phn_{10k}$	Phase noise at 10 kHz offset		-138		dBc/Hz
$phn_{100k}$	Phase noise at 100 kHz offset		-143.9		dBc/Hz
$phn_{1M}$	Phase noise at 1 MHz offset		-145.2		dBc/Hz
$phn_{10M}$	Phase noise at 10 MHz offset		-146.5		dBc/Hz
$phn_{20M}$	Phase noise at 20 MHz offset		-146.6		dBc/Hz
$t_{RJIT}$	Random additive jitter from 10 kHz to 20 MHz		65		fs, RMS

**TYPICAL CHARACTERISTICS**  
**INPUT CLOCK AND OUTPUT CLOCK PHASE NOISES**  
 vs  
**FREQUENCY FROM THE CARRIER ( $T_A = 25^\circ\text{C}$  and  $V_{CC} = 2.5\text{V}$ )**

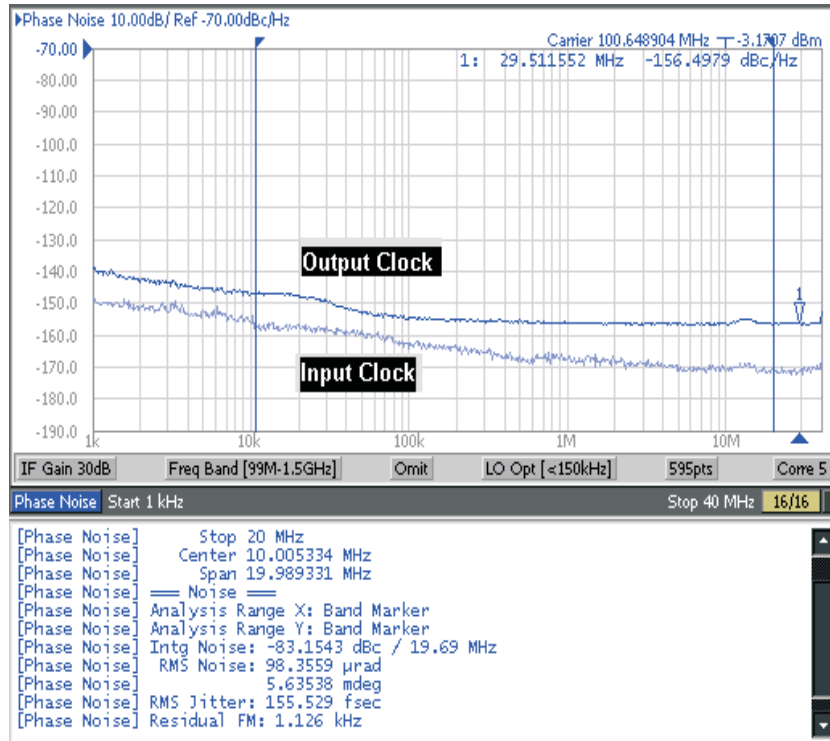

Input clock RMS jitter is 32 fs from 10 kHz to 20 MHz and additive RMS jitter is 152 fs

**Figure 3. 100 MHz Input and Output Phase Noise Plot**

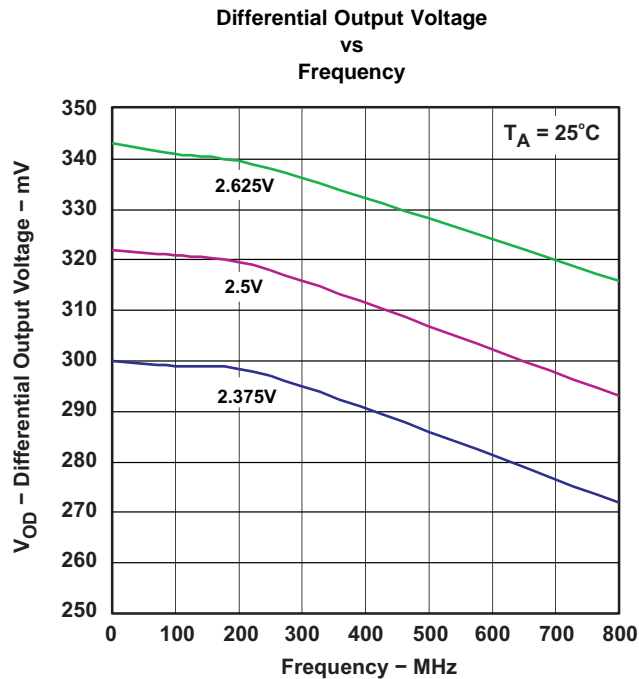

**Figure 4.**

TEST CONFIGURATIONS

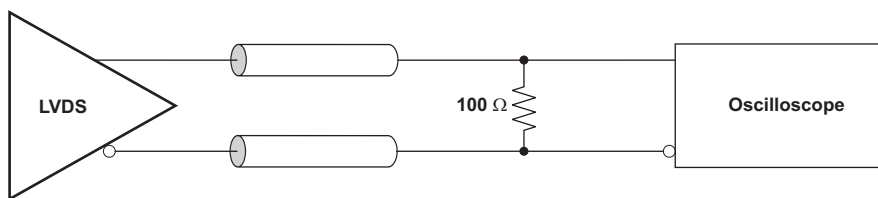

Figure 5. LVDS Output DC Configuration During Device Test

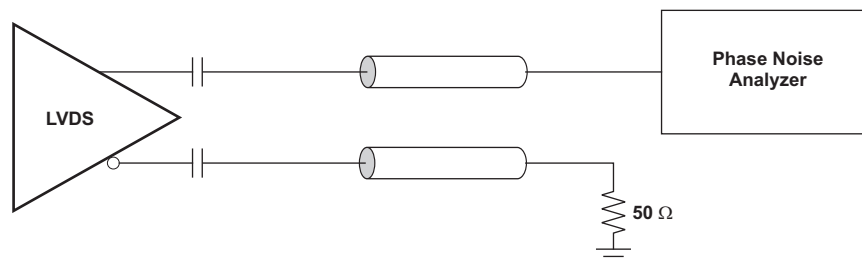

Figure 6. LVDS Output AC Configuration During Device Test

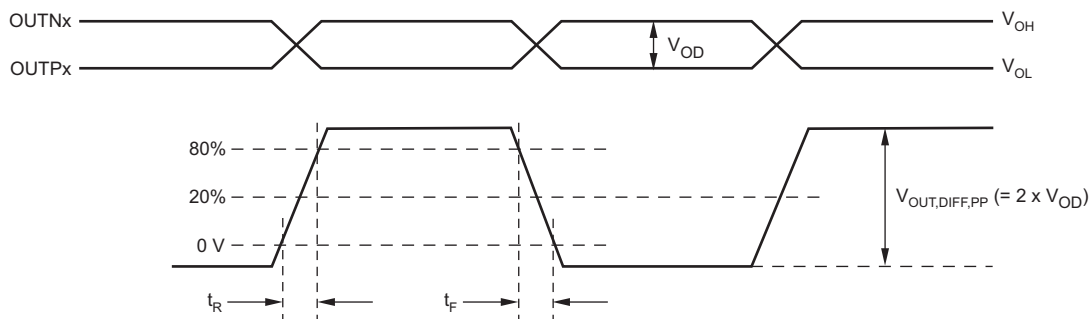
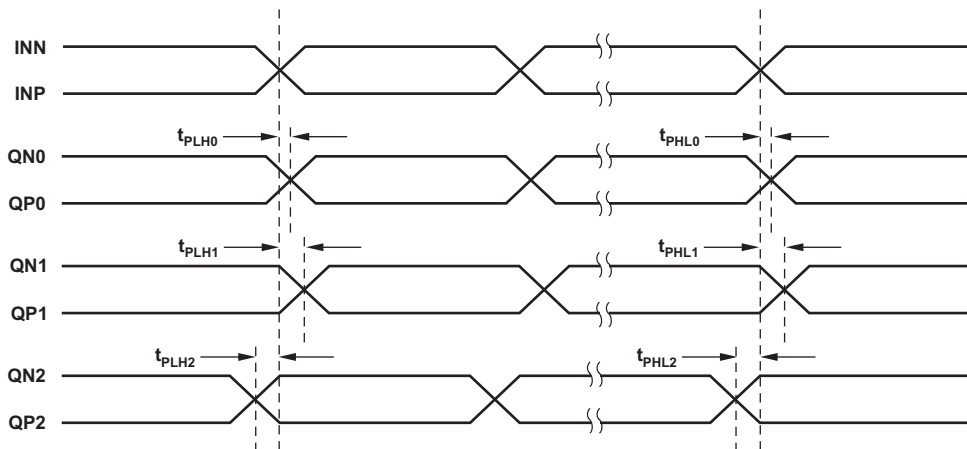

Figure 7. Output Voltage and Rise/Fall Time



- (1) Output skew is calculated as the greater of the following: As the difference between the fastest and the slowest  $t_{PLHn}$  or the difference between the fastest and the slowest  $t_{PHLn}$  ( $n = 0, 1, 2$ ).
- (2) Part-to-part skew is calculated as the greater of the following: As the difference between the fastest and the slowest  $t_{PLHn}$  or the difference between the fastest and the slowest  $t_{PHLn}$  across multiple devices ( $n = 0, 1, 2$ ).

Figure 8. Output and Part-to-Part Skew

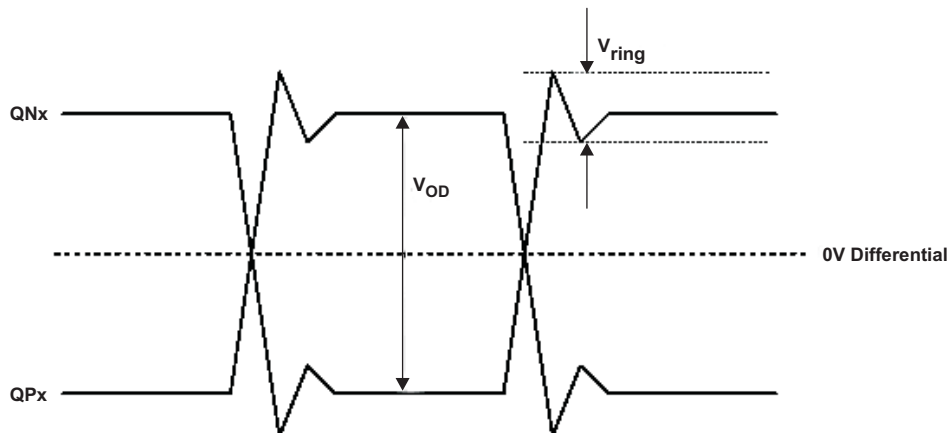

Figure 9. Output Overshoot and Undershoot

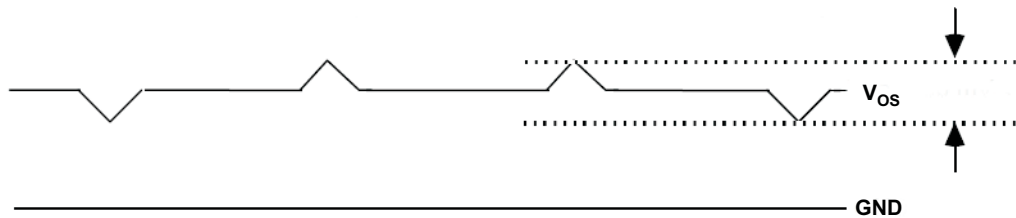

Figure 10. Output AC Common Mode

**APPLICATION INFORMATION**

**THERMAL MANAGEMENT**

For reliability and performance reasons, the die temperature should be limited to a maximum of 125°C.

The device package has an exposed pad that provides the primary heat removal path to the printed circuit board (PCB). To maximize the heat dissipation from the package, a thermal landing pattern including multiple vias to a ground plane must be incorporated into the PCB within the footprint of the package. The thermal pad must be soldered down to ensure adequate heat conduction to the package. Figure 11 shows a recommended land and via pattern.

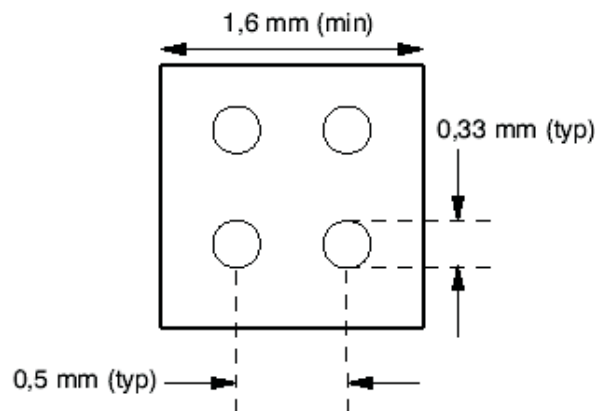

Figure 11. Recommended PCB Layout



## POWER-SUPPLY FILTERING

High-performance clock buffers are sensitive to noise on the power supply, which can dramatically increase the additive jitter of the buffer. Thus, it is essential to reduce noise from the system power supply, especially when jitter/phase noise is critical to applications.

Filter capacitors are used to eliminate the low-frequency noise from the power supply, where the bypass capacitors provide the low impedance path for high-frequency noise and guard the power-supply system against the induced fluctuations. These bypass capacitors also provide instantaneous current surges as required by the device and should have low equivalent series resistance (ESR). To properly use the bypass capacitors, they must be placed close to the power-supply pins and laid out with short loops to minimize inductance. It is recommended to add as many high-frequency (for example, 0.1  $\mu\text{F}$ ) bypass capacitors as there are supply pins in the package. It is recommended, but not required, to insert a ferrite bead between the board power supply and the chip power supply that isolates the high-frequency switching noises generated by the clock driver; these beads prevent the switching noise from leaking into the board supply. Choose an appropriate ferrite bead with low dc resistance because it is imperative to provide adequate isolation between the board supply and the chip supply, as well as to maintain a voltage at the supply pins that is greater than the minimum voltage required for proper operation.

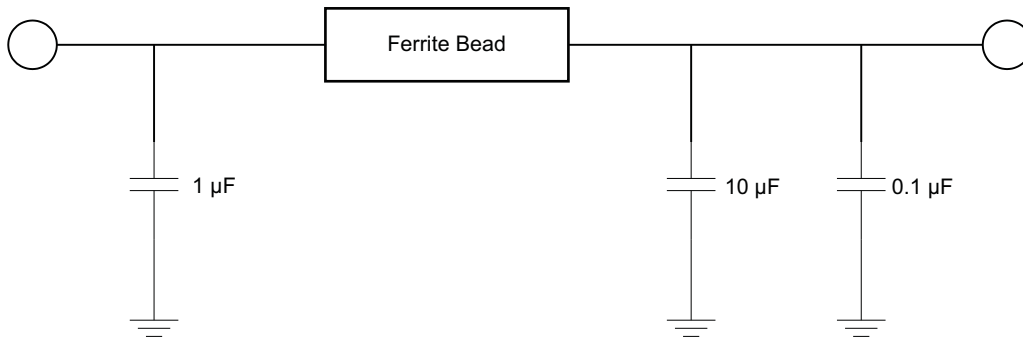

Figure 12. Power-Supply Decoupling

## LVDS OUTPUT TERMINATION

The proper LVDS termination for signal integrity over two 50  $\Omega$  lines is 100  $\Omega$  between the outputs on the receiver end. Either dc-coupled termination or ac-coupled termination can be used for LVDS outputs. It is recommended to place termination resistor close to the receiver. If the receiver is internally biased, ac-coupling should be used. If the LVDS receiver has internal 100  $\Omega$  termination, external termination is not required.

Unused outputs can be left open without connecting any traces to the output pins.

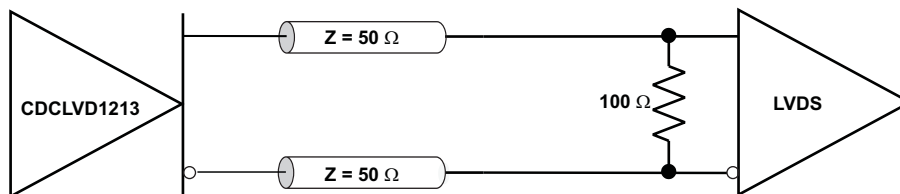

Figure 13. Output DC Termination

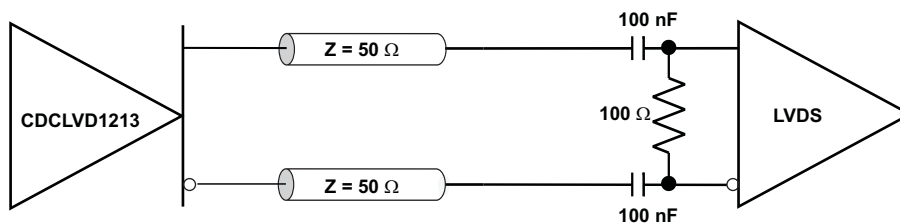

Figure 14. Output AC Termination (With Receiver Internally Biased)

## INPUT TERMINATION

The CDCLVD1213 input has internal  $140\ \Omega$  terminations, and an external  $350\ \Omega$  resistor is required for a  $50\ \Omega$  transmission line. It can be interfaced with LVDS, LVPECL, or CML drivers. LVDS input can be connected directly, dc or ac coupled. With ac coupling, external bias ( $V_{CC}/2$ ) must be provided to  $V_T$  pin.

Figure 16 illustrates how to connect CML input to CDCLVD1213 input buffer. The input does not have internal biasing, so external biasing ( $V_{CC}/2$  to  $V_T$ ) is required for ac coupling. If the CML output swing is  $>1.6\ V_{PP}$ , then signal swing needs to be reduced to meet  $V_{IN, DIF, PP} \leq 1.6\ V_{PP}$ .

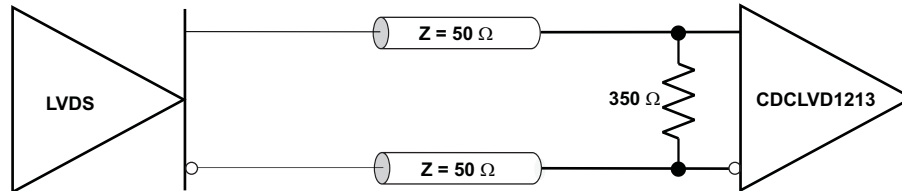

Figure 15. LVDS Clock Driver Connected to CDCLVD1213 Input

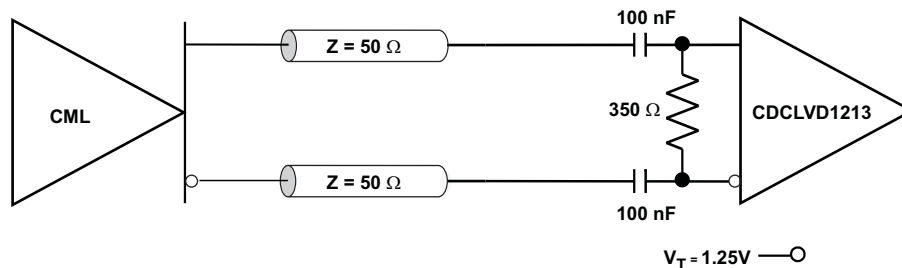

Figure 16. CML Clock Driver Connected to CDCLVD1213 Input

Figure 17 shows how to connect LVPECL input to the CDCLVD1213 input buffer. The input does not have internal biasing, so external biasing ( $V_{CC}/2$  to  $V_T$ ) is required for ac coupling. The series resistors are required to reduce the LVPECL signal swing if the signal swing is  $>1.6\ V_{pp}$ .

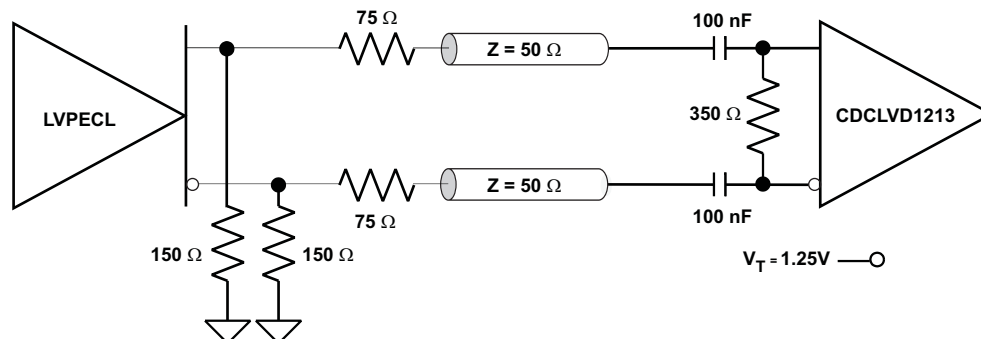

Figure 17. LVPECL Clock Driver Connected to CDCLVD1213 Input

**PACKAGING INFORMATION**

Orderable Device	Status (1)	Package Type	Package Drawing	Pins	Package Qty	Eco Plan (2)	Lead/Ball Finish	MSL Peak Temp (3)	Op Temp (°C)	Top-Side Markings (4)	Samples
CDCLVD1213RGTR	ACTIVE	QFN	RGT	16	3000	Green (RoHS & no Sb/Br)	CU NIPDAU	Level-2-260C-1 YEAR	-40 to 85	D1213	<a href="#">Samples</a>
CDCLVD1213RGTT	ACTIVE	QFN	RGT	16	250	Green (RoHS & no Sb/Br)	CU NIPDAU	Level-2-260C-1 YEAR	-40 to 85	D1213	<a href="#">Samples</a>

(1) The marketing status values are defined as follows:

**ACTIVE:** Product device recommended for new designs.

**LIFEBUY:** TI has announced that the device will be discontinued, and a lifetime-buy period is in effect.

**NRND:** Not recommended for new designs. Device is in production to support existing customers, but TI does not recommend using this part in a new design.

**PREVIEW:** Device has been announced but is not in production. Samples may or may not be available.

**OBSOLETE:** TI has discontinued the production of the device.

(2) Eco Plan - The planned eco-friendly classification: Pb-Free (RoHS), Pb-Free (RoHS Exempt), or Green (RoHS & no Sb/Br) - please check <http://www.ti.com/productcontent> for the latest availability information and additional product content details.

**TBD:** The Pb-Free/Green conversion plan has not been defined.

**Pb-Free (RoHS):** TI's terms "Lead-Free" or "Pb-Free" mean semiconductor products that are compatible with the current RoHS requirements for all 6 substances, including the requirement that lead not exceed 0.1% by weight in homogeneous materials. Where designed to be soldered at high temperatures, TI Pb-Free products are suitable for use in specified lead-free processes.

**Pb-Free (RoHS Exempt):** This component has a RoHS exemption for either 1) lead-based flip-chip solder bumps used between the die and package, or 2) lead-based die adhesive used between the die and leadframe. The component is otherwise considered Pb-Free (RoHS compatible) as defined above.

**Green (RoHS & no Sb/Br):** TI defines "Green" to mean Pb-Free (RoHS compatible), and free of Bromine (Br) and Antimony (Sb) based flame retardants (Br or Sb do not exceed 0.1% by weight in homogeneous material)

(3) MSL, Peak Temp. -- The Moisture Sensitivity Level rating according to the JEDEC industry standard classifications, and peak solder temperature.

(4) Multiple Top-Side Markings will be inside parentheses. Only one Top-Side Marking contained in parentheses and separated by a "~" will appear on a device. If a line is indented then it is a continuation of the previous line and the two combined represent the entire Top-Side Marking for that device.

**Important Information and Disclaimer:** The information provided on this page represents TI's knowledge and belief as of the date that it is provided. TI bases its knowledge and belief on information provided by third parties, and makes no representation or warranty as to the accuracy of such information. Efforts are underway to better integrate information from third parties. TI has taken and continues to take reasonable steps to provide representative and accurate information but may not have conducted destructive testing or chemical analysis on incoming materials and chemicals. TI and TI suppliers consider certain information to be proprietary, and thus CAS numbers and other limited information may not be available for release.

In no event shall TI's liability arising out of such information exceed the total purchase price of the TI part(s) at issue in this document sold by TI to Customer on an annual basis.

**TAPE AND REEL INFORMATION**

**REEL DIMENSIONS**



**TAPE DIMENSIONS**



A0	Dimension designed to accommodate the component width
B0	Dimension designed to accommodate the component length
K0	Dimension designed to accommodate the component thickness
W	Overall width of the carrier tape
P1	Pitch between successive cavity centers

**TAPE AND REEL INFORMATION**

\*All dimensions are nominal

Device	Package Type	Package Drawing	Pins	SPQ	Reel Diameter (mm)	Reel Width W1 (mm)	A0 (mm)	B0 (mm)	K0 (mm)	P1 (mm)	W (mm)	Pin1 Quadrant
CDCLVD1213RGTR	QFN	RGT	16	3000	330.0	12.4	3.3	3.3	1.1	8.0	12.0	Q2
CDCLVD1213RGTT	QFN	RGT	16	250	330.0	12.4	3.3	3.3	1.1	8.0	12.0	Q2

**TAPE AND REEL BOX DIMENSIONS**

\*All dimensions are nominal

Device	Package Type	Package Drawing	Pins	SPQ	Length (mm)	Width (mm)	Height (mm)
CDCLVD1213RGTR	QFN	RGT	16	3000	338.1	338.1	20.6
CDCLVD1213RGTT	QFN	RGT	16	250	338.1	338.1	20.6

RGT (S-PVQFN-N16)

PLASTIC QUAD FLATPACK NO-LEAD



4203495/H 10/11

- NOTES:
- All linear dimensions are in millimeters. Dimensioning and tolerancing per ASME Y14.5M-1994.
  - This drawing is subject to change without notice.
  - Quad Flatpack, No-leads (QFN) package configuration.
  - The package thermal pad must be soldered to the board for thermal and mechanical performance.
  - See the additional figure in the Product Data Sheet for details regarding the exposed thermal pad features and dimensions.
  - Falls within JEDEC MO-220.

# THERMAL PAD MECHANICAL DATA

RGT (S-PVQFN-N16)

PLASTIC QUAD FLATPACK NO-LEAD

## THERMAL INFORMATION

This package incorporates an exposed thermal pad that is designed to be attached directly to an external heatsink. The thermal pad must be soldered directly to the printed circuit board (PCB). After soldering, the PCB can be used as a heatsink. In addition, through the use of thermal vias, the thermal pad can be attached directly to the appropriate copper plane shown in the electrical schematic for the device, or alternatively, can be attached to a special heatsink structure designed into the PCB. This design optimizes the heat transfer from the integrated circuit (IC).

For information on the Quad Flatpack No-Lead (QFN) package and its advantages, refer to Application Report, QFN/SON PCB Attachment, Texas Instruments Literature No. SLUA271. This document is available at [www.ti.com](http://www.ti.com).

The exposed thermal pad dimensions for this package are shown in the following illustration.

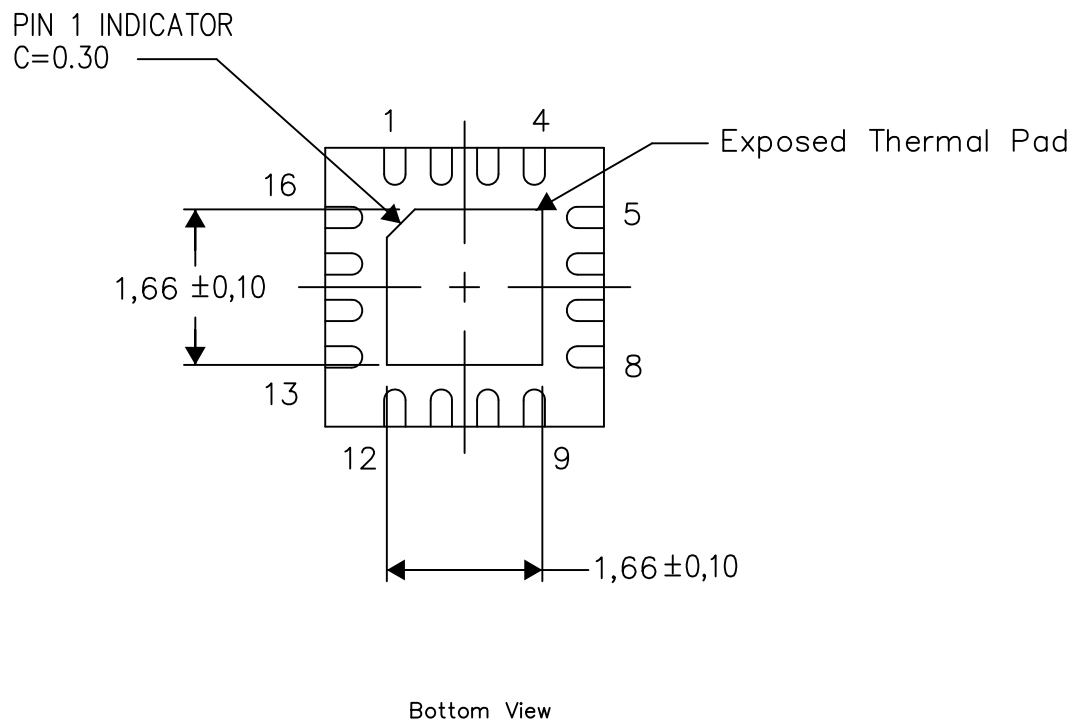

Exposed Thermal Pad Dimensions

4206349-9/T 05/13

NOTE: All linear dimensions are in millimeters

## IMPORTANT NOTICE

Texas Instruments Incorporated and its subsidiaries (TI) reserve the right to make corrections, enhancements, improvements and other changes to its semiconductor products and services per JESD46, latest issue, and to discontinue any product or service per JESD48, latest issue. Buyers should obtain the latest relevant information before placing orders and should verify that such information is current and complete. All semiconductor products (also referred to herein as "components") are sold subject to TI's terms and conditions of sale supplied at the time of order acknowledgment.

TI warrants performance of its components to the specifications applicable at the time of sale, in accordance with the warranty in TI's terms and conditions of sale of semiconductor products. Testing and other quality control techniques are used to the extent TI deems necessary to support this warranty. Except where mandated by applicable law, testing of all parameters of each component is not necessarily performed.

TI assumes no liability for applications assistance or the design of Buyers' products. Buyers are responsible for their products and applications using TI components. To minimize the risks associated with Buyers' products and applications, Buyers should provide adequate design and operating safeguards.

TI does not warrant or represent that any license, either express or implied, is granted under any patent right, copyright, mask work right, or other intellectual property right relating to any combination, machine, or process in which TI components or services are used. Information published by TI regarding third-party products or services does not constitute a license to use such products or services or a warranty or endorsement thereof. Use of such information may require a license from a third party under the patents or other intellectual property of the third party, or a license from TI under the patents or other intellectual property of TI.

Reproduction of significant portions of TI information in TI data books or data sheets is permissible only if reproduction is without alteration and is accompanied by all associated warranties, conditions, limitations, and notices. TI is not responsible or liable for such altered documentation. Information of third parties may be subject to additional restrictions.

Resale of TI components or services with statements different from or beyond the parameters stated by TI for that component or service voids all express and any implied warranties for the associated TI component or service and is an unfair and deceptive business practice. TI is not responsible or liable for any such statements.

Buyer acknowledges and agrees that it is solely responsible for compliance with all legal, regulatory and safety-related requirements concerning its products, and any use of TI components in its applications, notwithstanding any applications-related information or support that may be provided by TI. Buyer represents and agrees that it has all the necessary expertise to create and implement safeguards which anticipate dangerous consequences of failures, monitor failures and their consequences, lessen the likelihood of failures that might cause harm and take appropriate remedial actions. Buyer will fully indemnify TI and its representatives against any damages arising out of the use of any TI components in safety-critical applications.

In some cases, TI components may be promoted specifically to facilitate safety-related applications. With such components, TI's goal is to help enable customers to design and create their own end-product solutions that meet applicable functional safety standards and requirements. Nonetheless, such components are subject to these terms.

No TI components are authorized for use in FDA Class III (or similar life-critical medical equipment) unless authorized officers of the parties have executed a special agreement specifically governing such use.

Only those TI components which TI has specifically designated as military grade or "enhanced plastic" are designed and intended for use in military/aerospace applications or environments. Buyer acknowledges and agrees that any military or aerospace use of TI components which have **not** been so designated is solely at the Buyer's risk, and that Buyer is solely responsible for compliance with all legal and regulatory requirements in connection with such use.

TI has specifically designated certain components as meeting ISO/TS16949 requirements, mainly for automotive use. In any case of use of non-designated products, TI will not be responsible for any failure to meet ISO/TS16949.

### Products

Audio	<a href="http://www.ti.com/audio">www.ti.com/audio</a>
Amplifiers	<a href="http://amplifier.ti.com">amplifier.ti.com</a>
Data Converters	<a href="http://dataconverter.ti.com">dataconverter.ti.com</a>
DLP® Products	<a href="http://www.dlp.com">www.dlp.com</a>
DSP	<a href="http://dsp.ti.com">dsp.ti.com</a>
Clocks and Timers	<a href="http://www.ti.com/clocks">www.ti.com/clocks</a>
Interface	<a href="http://interface.ti.com">interface.ti.com</a>
Logic	<a href="http://logic.ti.com">logic.ti.com</a>
Power Mgmt	<a href="http://power.ti.com">power.ti.com</a>
Microcontrollers	<a href="http://microcontroller.ti.com">microcontroller.ti.com</a>
RFID	<a href="http://www.ti-rfid.com">www.ti-rfid.com</a>
OMAP Applications Processors	<a href="http://www.ti.com/omap">www.ti.com/omap</a>
Wireless Connectivity	<a href="http://www.ti.com/wirelessconnectivity">www.ti.com/wirelessconnectivity</a>

### Applications

Automotive and Transportation	<a href="http://www.ti.com/automotive">www.ti.com/automotive</a>
Communications and Telecom	<a href="http://www.ti.com/communications">www.ti.com/communications</a>
Computers and Peripherals	<a href="http://www.ti.com/computers">www.ti.com/computers</a>
Consumer Electronics	<a href="http://www.ti.com/consumer-apps">www.ti.com/consumer-apps</a>
Energy and Lighting	<a href="http://www.ti.com/energy">www.ti.com/energy</a>
Industrial	<a href="http://www.ti.com/industrial">www.ti.com/industrial</a>
Medical	<a href="http://www.ti.com/medical">www.ti.com/medical</a>
Security	<a href="http://www.ti.com/security">www.ti.com/security</a>
Space, Avionics and Defense	<a href="http://www.ti.com/space-avionics-defense">www.ti.com/space-avionics-defense</a>
Video and Imaging	<a href="http://www.ti.com/video">www.ti.com/video</a>

### TI E2E Community

[e2e.ti.com](http://e2e.ti.com)