

ADVANCED UNIVERSAL SERIAL BUS TRANSCEIVER

FEATURES

- Complies With Universal Serial Bus Specification Rev. 2.0 (USB 2.0)
- Transmits and Receives Serial Data at Both Full-Speed (12-Mbit/s) and Low-Speed (1.5-Mbit/s) Data Rates
- Integrated Bypassable 5-V to 3.3-V Voltage Regulator for Powering Via USB V_{BUS}
- Low-Power Operation is Ideal for Portable Equipment
- Meets the IEC-61000-4-2 Contact Discharge (± 9 kV) and Air-Gap Discharge (± 9 kV) ESD Ratings
- Separate I/O Supply With Operation Down to 1.65 V
- Very-Low Power Consumption to Meet USB Suspend Current Requirements
- No Power-Supply Sequencing Requirements

APPLICATIONS

- Cellular Phones
- Personal Digital Assistants (PDAs)
- Handheld Computers

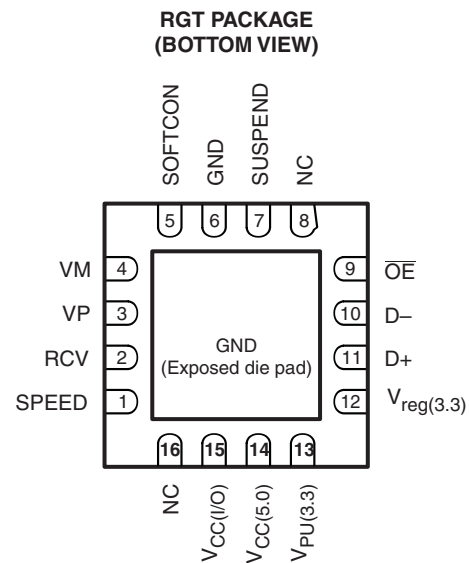
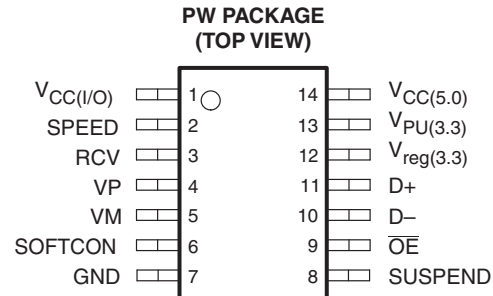

NC – No internal connection

DESCRIPTION/ORDERING INFORMATION

The TUSB2551A is a single-chip transceiver that complies with the physical-layer specifications of universal serial bus (USB) 2.0. The device supports both full-speed (12-Mbit/s) and low-speed (1.5-Mbit/s) operation. The TUSB2551A delivers superior edge-rate control, producing crisper eye diagrams, which ease the task of passing USB compliance testing.

A dual supply-voltage operation allows the TUSB2551A to reference the system interface I/O signals to a supply voltage down to 1.6 V, while independently powered by the USB $V_{CC(5.0)}$. This allows the system interface to operate at its core voltage without the addition of buffering logic, and also reduce system operating current.



Please be aware that an important notice concerning availability, standard warranty, and use in critical applications of Texas Instruments semiconductor products and disclaimers thereto appears at the end of this data sheet.

ORDERING INFORMATION⁽¹⁾

T _A	PACKAGE ⁽²⁾		ORDERABLE PART NUMBER	TOP-SIDE MARKING
–40°C to 85°C	QFN – RGT	Reel of 2000	TUSB2551ARGTR	ZUH
	TSSOP – PW	Reel of 3000	TUSB2551APWR	PREVIEW
		Tube of 90	TUSB2551APW	

- (1) For the most current package and ordering information, see the Package Option Addendum at the end of this document, or see the TI web site at www.ti.com.
- (2) Package drawings, thermal data, and symbolization are available at www.ti.com/packaging.

BLOCK DIAGRAM

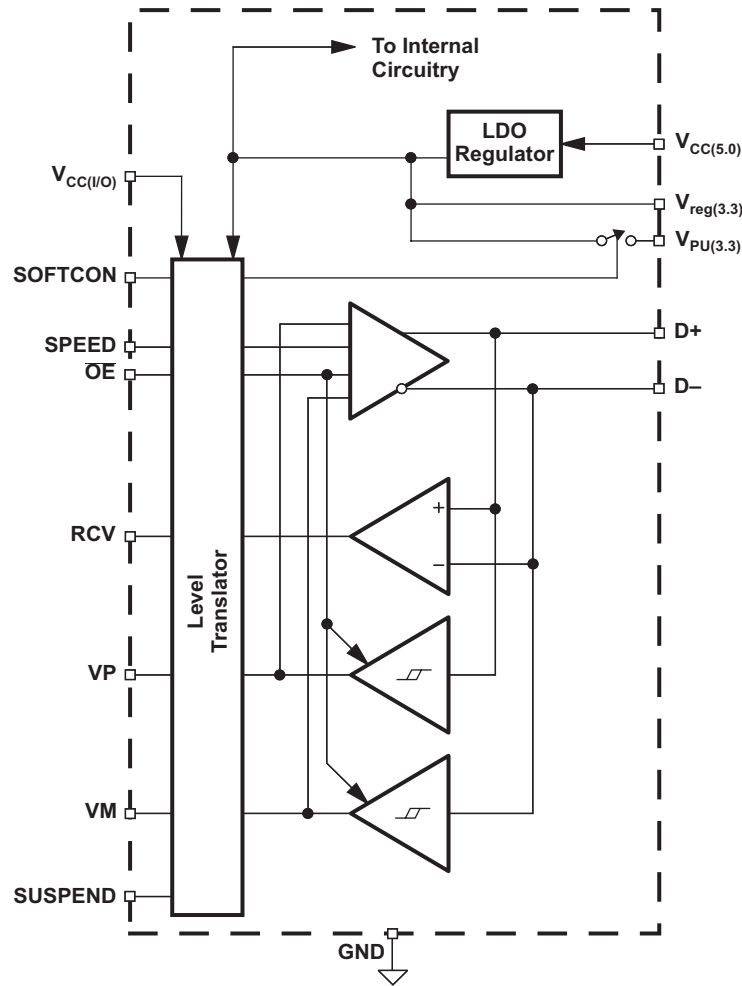

TERMINAL FUNCTIONS

TERMINAL			I/O	DESCRIPTION
NAME	NO.			
	RGT	PW		
$V_{CC(I/O)}$	15	1	I	System interface supply voltage. Used to provide reference supply voltage for system I/O interface signaling.
SPEED	1	2	I	Speed. Edge-rate control: A logic HIGH operates at edge rates for full-speed operation. A logic LOW operates at edge rates for low-speed operation.
RCV	2	3	O	Receive data. Output for USB differential data.
VP	3	4	I/O	If $\overline{OE} = 1$, VP = Receiver output (+) If $\overline{OE} = 0$, VP = Driver input (+)
VM	4	5	I/O	If $\overline{OE} = 1$, VM = Receiver output (-) If $\overline{OE} = 0$, VM = Driver input (-)
SOFTCON	5	6	I	Soft connect. Controls state of $V_{PU(3,3)}$. See $V_{PU(3,3)}$ pin description for details.
GND	6	7		Ground reference
SUSPEND	7	8	I	Suspend. Active high. Turns off internal circuits to reduce supply current.
NC	8, 16			No internal connection
\overline{OE}	9	9	I	Output enable. Active low. Enables the transceiver to transmit data onto the bus. When inactive, the transceiver is in the receive mode.
D-, D+	10, 11	10, 11	I/O	Differential data lines conforming to the USB standard
$V_{reg(3,3)}$	12	12	O	3.3-V reference supply. Requires a minimum 0.1- μ F decoupling capacitor for stability. A 1- μ F capacitor is recommended.
$V_{PU(3,3)}$	13	13	O	Pullup supply voltage. Used to connect 1.5-k Ω pullup speed detect resistor. If SOFTCON = 1, $V_{PU(3,3)}$ is high impedance. If SOFTCON = 0, $V_{PU(3,3)} = 3.3$ V.
$V_{CC(5,0)}$	14	14	I	USB bus supply voltage. Used to power USB transceiver and internal circuitry.

FUNCTIONAL DESCRIPTION
FUNCTION SELECTION

SUSPEND	\overline{OE}	D+, D-	RCV	VP, VM	FUNCTION
0	0	Driving	Active	Active	Normal transmit mode
0	1	Receiving	Active	Active	Normal receive mode
1	0	Hi-Z	0	Not active	Low power state
1	1	Hi-Z	0	Active	Receiving during suspend (low power state) ⁽¹⁾

(1) During suspend, VP and VM are active to detect out-of-band signaling conditions.

TRUTH TABLE DURING NORMAL MODE

$\overline{OE} = 0$					
INPUT		OUTPUT			RESULT
VP	VM	D+	D-	RCV	
0	0	0	0	X ⁽¹⁾	SE0
0	1	0	1	0	Logic 0
1	0	1	0	1	Logic 1
1	1	1	1	X ⁽¹⁾	Undefined
$\overline{OE} = 1$					
INPUT		OUTPUT			RESULT
D+	D-	VP	VM	RCV	
0	0	0	0	X ⁽¹⁾	SE0
0	1	0	1	0	Logic 0
1	0	1	0	1	Logic 1
1	1	1	1	X ⁽¹⁾	Undefined

(1) X = Undefined

Power-Supply Configurations

The TUSB2551A can be used with different power-supply configurations, which can be dynamically changed. An overview is given in [Table 1](#).

- Normal mode – Both $V_{CC(I/O)}$ and $V_{CC(5.0)}$ or $V_{CC(5.0)}$ and $V_{reg(3.3)}$ are connected. For 5-V operation, $V_{CC(5.0)}$ is connected to a 5-V source (4 V to 5.5 V). The internal voltage regulator then produces 3.3 V for the USB connections. For 3.3-V operation, both $V_{CC(5.0)}$ and $V_{reg(3.3)}$ are connected to a 3.3-V source (3 V to 3.6 V). $V_{CC(I/O)}$ is independently connected to a voltage source (1.65 V to 3.6 V), depending on the supply voltage of the external circuit.
- Disable mode – $V_{CC(I/O)}$ is not connected; $V_{CC(5.0)}$ or $V_{CC(5.0)}$ and $V_{reg(3.3)}$ are connected. In this mode, the internal circuits of the TUSB2551A ensure that the D+ and D– pins are in 3-state, and the power consumption drops to the low-power (suspended) state level. Some hysteresis is built into the detection of $V_{CC(I/O)}$ lost.
- Sharing mode – $V_{CC(I/O)}$ is connected; $V_{CC(5.0)}$ and $V_{reg(3.3)}$ are not connected. In this mode, the D+ and D– pins are made 3-state, and the TUSB2551A allows external signals of up to 3.6 V to share the D+ and D– lines. The internal circuits of the TUSB2551A ensure that virtually no current (maximum 10 mA) is drawn via the D+ and D– lines. The power consumption through $V_{CC(I/O)}$ drops to the low-power (suspended) state level. Both the VP and VM pins are driven HIGH to indicate this mode. Pin RCV is made LOW. Some hysteresis is built into the detection of $V_{reg(3.3)}$ lost.

Table 1. Power-Supply Configuration Overview

CONFIGURATION MODE	VBUS/VTRM	VIF	Notes
Normal	Connected	Connected	Normal supply configuration and operation
Disconnect (D+/D– sharing)	Open	Connected	VP/VM are HIGH outputs, RCV is LOW. With $\overline{OE} = 0$ and SUSPEND = 1, data lines may be driven with external devices up to 3.6 V. With D+, D– floating, $I_{CC(I/O)}$ draws less than 1 μ A.
Disconnect	Ground	Connected	VP/VM are HIGH outputs, RCV is LOW. With D+, D– floating, $I_{CC(I/O)F}$ draws less than 1 μ A.
Disable Mode	Connected	Open	Logic controlled inputs pins are Hi-Z.
Prohibited	Connected	Ground	Prohibited condition

Table 2. Pin States in Disable or Sharing Mode

PINS	DISABLE-MODE STATE	SHARING-MODE STATE
$V_{CC(5.0)}/V_{reg(3.3)}$	5-V input/3.3-V output, 3.3-V input/3.3-V input	Not present
$V_{CC(I/O)}$	Not present	1.65-V to 3.6-V input
$V_{PU(3.3)}$	High impedance (off)	High impedance (off)
D+, D–	High impedance	High impedance
VP, VM	Invalid ⁽¹⁾	H
RCV	Invalid ⁽¹⁾	L
Inputs (SPEED, SUSPEND, \overline{OE} , SOFTCON)	High impedance	High impedance

(1) High impedance or driven LOW

Power-Supply Input Options

The TUSB2551A has two power-supply input options.

- Internal regulator – $V_{CC(5.0)}$ is connected to 4 V to 5.5 V. The internal regulator is used to supply the internal circuitry with 3.3 V (nominal). $V_{reg(3.3)}$ becomes a 3.3-V output reference.
- Regulator bypass – $V_{CC(5.0)}$ and $V_{reg(3.3)}$ are connected to the same supply. The internal regulator is bypassed, and the internal circuitry is supplied directly from the $V_{reg(3.3)}$ power supply. The voltage range is 3 V to 3.6 V to comply with the USB specification.

The supply-voltage range for each input option is specified in [Table 3](#).

Table 3. Power-Supply Input Options

INPUT OPTION	$V_{CC(5.0)}$	$V_{reg(3.3)}$	$V_{CC(I/O)}$
Internal regulator	Supply input for internal regulator (4 V to 5.5 V)	Voltage-reference output (3.3 V, 300 μ A)	Supply input for digital I/O pins (1.4 V to 3.6 V)
Regulator bypass	Connected to $V_{reg(3.3)}$ with maximum voltage drop of 0.3 V (2.7 V to 3.6 V)	Supply input (3 V to 3.6 V)	Supply input for digital I/O pins (1.4 V to 3.6 V)

Electrostatic Discharge (ESD)

PIN NAME	ESD	TYP	UNIT
D+, D–, $V_{CC(5.0)}$	IEC61000-4-2, Air-Gap Discharge	± 9	kV
	IEC61000-4-2, Contact Discharge	± 9	
	Human-Body Model	± 15	
All other pins	Human-Body Model	± 2	kV

ABSOLUTE MAXIMUM RATINGS⁽¹⁾

over operating free-air temperature range (unless otherwise noted)

		MIN	MAX	UNIT
$V_{CC(5.0)}$	Supply voltage range	-0.5	6	V
$V_{CC(I/O)}$	I/O supply voltage range	-0.5	4.6	V
$V_{reg(3.3)}$	Regulated voltage range	-0.5	4.6	V
V_I	DC input voltage range	-0.5	$V_{CC(I/O)} + 0.5$	mA
$I_{O(D+, D-)}$	Output current (D+, D-)		±50	mA
I_O	Output current (all others)		±15	mA
I_I	Input Current		±50	mA
T_{stg}	Storage temperature range	-65	150	°C

(1) Stresses beyond those listed under "absolute maximum ratings" may cause permanent damage to the device. These are stress ratings only, and functional operation of the device at these or any other conditions beyond those indicated under "recommended operating conditions" is not implied. Exposure to absolute-maximum-rated conditions for extended periods may affect device reliability.

RECOMMENDED OPERATING CONDITIONS

			MIN	NOM	MAX	UNIT
$V_{CC(5.0)}$	Supply voltage, internal regulator option	5-V operation	4	5	5.25	V
$V_{reg(3.3)}$	Supply voltage, regulator bypass option	3.3-V operation	3	3.3	3.6	V
$V_{CC(I/O)}$	I/O supply voltage		1.65		3.6	V
V_{IL}	Low-level input voltage ⁽¹⁾		$V_{CC(I/O)} - 0.3$		$0.15 V_{CC(I/O)}$	V
V_{IH}	High-level input voltage ⁽¹⁾		$0.85 V_{CC(I/O)}$		$V_{CC(I/O)} + 0.3$	V
D+, D-	Input voltage on analog I/O pins		0		3.6	V
T_c	Junction temperature		-40		85	°C

(1) Specification applies to the following pins: SUSPEND, SPEED, RCV, SOFTCON, VP, VM, and \overline{OE} .

DC ELECTRICAL CHARACTERISTICS – SYSTEM AND USB INTERFACE⁽¹⁾
 $V_{CC(I/O)} = 3.6\text{ V}$, $V_{CC(5.0)} = 5\text{ V}$ (unless otherwise noted), $T_A = 25^\circ\text{C}$. Bold indicates specifications over temperature, -40°C to 85°C .

PARAMETER		TEST CONDITIONS					MIN	TYP	MAX	UNIT	
V_{OH}	High-level output voltage ⁽²⁾	$I_{OH} = 20\ \mu\text{A}$					$0.9\ V_{CC(I/O)}$			V	
V_{OL}	Low-level output voltage ⁽²⁾	$I_{OL} = 20\ \mu\text{A}$								0.1	V
I_{IL}	Input leakage current ⁽²⁾						-5	1.5	5	μA	
$I_{CC(I/O)}$	$V_{CC(I/O)}$ supply current	SPEED	SUSPEND	\overline{OE}	VOLTAGE	LOAD					
		1	0	1	$V_{CC(5.0)} = 5.25\text{ V}$, $V_{CC(I/O)} = 3.6\text{ V}$		1	5	μA		
		1	0	0			1	5			
		0	0	1			1	5			
		0	0	0			1	5			
		0	1	0			1	5			
		1	0	0		$f = 6\text{ MHz}$, $C_L = 50\text{ pF}$	1	2		mA	
		0	0	0	$f = 750\text{ kHz}$, $C_L = 600\text{ pF}$	260	280	μA			
$I_{CC(5.0)}$	$V_{CC(5.0)}$ supply current	1	0	1	$V_{CC(5.0)} = 5.25\text{ V}$, $V_{CC(I/O)} = 3.6\text{ V}$		800	1100	μA		
		1	0	0			3000	5000			
		0	0	1			230	350			
		0	0	0			400	700			
		0	1	0			130	200			
		1	0	0		$f = 6\text{ MHz}$, $C_L = 50\text{ pF}$	6	10		mA	
		0	0	0	$f = 750\text{ kHz}$, $C_L = 600\text{ pF}$	4.3	5				
		$I_{PU(3.3)LEAK}$	$V_{PU(3.3)}$ leakage current	SOFTCON = 1, $V_{PU(3.3)} = 0\text{ V}$					-5		5
$I_{CC(I/O)LEAK}$	$V_{CC(I/O)}$ leakage current	$V_{CC(I/O)} = 3.6\text{ V}$, $V_{CC(5.0)} = 0\text{ V}$					-5		5	μA	
$V_{PU(3.3)}$	Pullup output voltage	$I_{reg(3.3)} = 200\ \mu\text{A}$, $V_{CC(5.0)} = 4\text{ V}$ to 5.25 V					3	3.3	3.6	V	
R_{SW}	$V_{PU(3.3)}$ switch resistance	$I_{reg(3.3)} = 10\text{ mA}$, $V_{CC(5.0)} = 4\text{ V}$ to 5.25 V					10			Ω	
ESD Protection											
IEC-61000-4-2 (D+, D-, $V_{CC(5.0)}$ only)	Air-Gap Discharge	10 pulses					± 9			kV	
	Contact Discharge	10 pulses					± 9				

(1) Specification for packaged product only

(2) Specification applies to the following pins: RCV, VP, VM, \overline{OE} .

DC ELECTRICAL CHARACTERISTICS – TRANSCEIVER ⁽¹⁾

PARAMETER		TEST CONDITIONS	MIN	TYP	MAX	UNIT
Leakage Current						
I_{LO}	Hi-Z state data line leakage (suspend mode)	$0\text{ V} < V_{IN} < 3.3\text{ V}$, SUSPEND = 1	-10		10	μA
Input Levels						
V_{DI}	Differential input sensitivity	$ (D+) - (D-) $	0.2			V
V_{CM}	Differential common mode range	Includes V_{DI} range	0.8		2.5	V
V_{SE}	Single-ended receiver threshold		0.8		2	V
	Receiver hysteresis			200		mV
Output Levels						
V_{OL}	Static output low	$R_L = 1.5\text{ k}\Omega$ to 3.6 V			0.3	V
V_{OH}	Static output high	$R_L = 15\text{ k}\Omega$ to GND	2.8		3.6	V
Capacitance						
C_{IN}	Transceiver capacitance	Pin to GND		10		pF
Z_{DRV}	Driver output resistance	Steady-state drive	1	6	11	Ω

(1) Specification for packaged product only

AC ELECTRICAL CHARACTERISTICS⁽¹⁾

PARAMETER		TEST CONDITIONS	MIN	MAX	UNIT
Driver Characteristics (Low Speed)					
T_R	Transition rise time	$C_L = 200 \text{ pF}$ (see Figure 2), $C_L = 600 \text{ pF}$	75	300	ns
T_F	Transition fall time	$C_L = 200 \text{ pF}$ (see Figure 2), $C_L = 600 \text{ pF}$	75	300	ns
LRFM	Rise/fall time matching	T_R, T_F	80	125	%
V_{CRS}	Output signal crossover voltage		1.3	2	V
Driver Characteristics (Full Speed)					
T_R	Transition rise time	$C_L = 50 \text{ pF}$ (see Figure 2)	4	20	ns
T_F	Transition fall time	$C_L = 50 \text{ pF}$ (see Figure 2)	4	20	ns
FRFM	Rise/fall time matching	T_R, T_F	90	111.1	%
V_{CRS}	Output signal crossover voltage		1.3	2	V
Transceiver Timing (Full Speed)					
t_{PVZ}	\overline{OE} to receiver 3-state delay	See Figure 1		15	ns
t_{PZD}	Receiver 3-state to transmit delay	See Figure 1	15		ns
t_{PDZ}	\overline{OE} to driver 3-state delay	See Figure 1		15	ns
t_{PZV}	Driver 3-state to receive delay	See Figure 1	15		ns
t_{PLH} t_{PHL}	V_P, V_M to D+, D– propagation delay	See Figure 4		17	ns
t_{PLH} t_{PHL}	D+, D– to RCV propagation delay	See Figure 3		17	ns
t_{PLH} t_{PHL}	D+, D– to V_P, V_M propagation delay	See Figure 3		10	ns

(1) Specification for packaged product only

TIMING DIAGRAMS

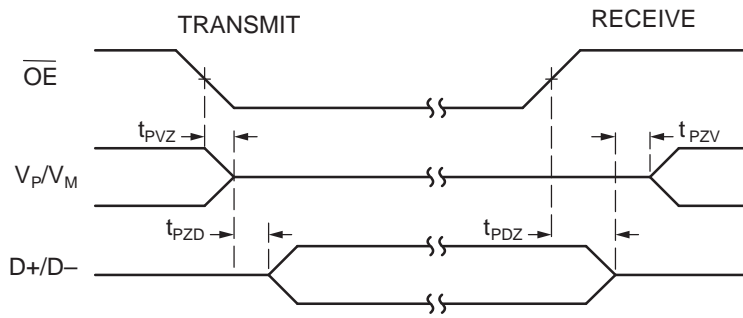

Figure 1. Enable and Disable Times

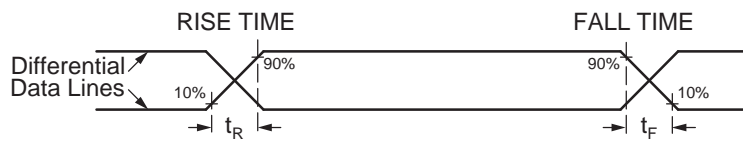

Figure 2. Rise and Fall Times

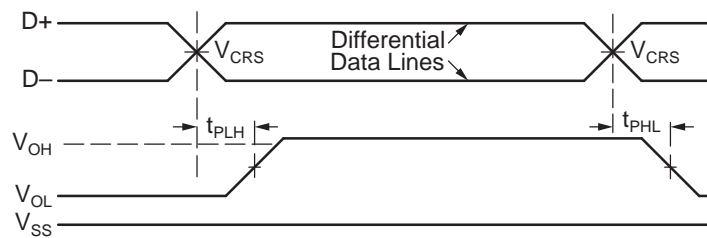

Figure 3. Receiver Propagation Delay

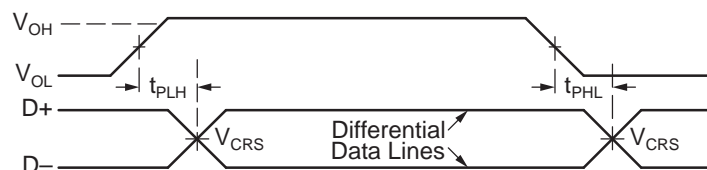

Figure 4. Driver Propagation Delay

TEST CIRCUITS

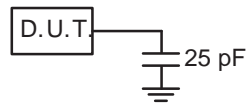

Figure 5. Load for V_p , V_m , RCV

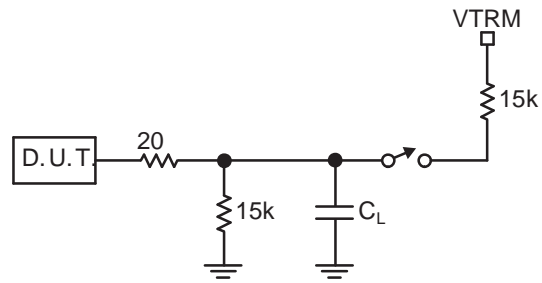

Figure 6. Load for D_+ , D_-

PACKAGING INFORMATION

Orderable Device	Status (1)	Package Type	Package Drawing	Pins	Package Qty	Eco Plan (2)	Lead/Ball Finish	MSL Peak Temp (3)	Op Temp (°C)	Device Marking (4/5)	Samples
TUSB2551APW	PREVIEW	TSSOP	PW	14		TBD	Call TI	Call TI	-40 to 85		
TUSB2551APWR	PREVIEW	TSSOP	PW	16	2000	TBD	Call TI	Call TI	-40 to 85		
TUSB2551ARGTR	ACTIVE	QFN	RGT	16	3000	Green (RoHS & no Sb/Br)	CU NIPDAU	Level-1-260C-UNLIM	-40 to 85	ZUH	Samples

(1) The marketing status values are defined as follows:

ACTIVE: Product device recommended for new designs.

LIFEBUY: TI has announced that the device will be discontinued, and a lifetime-buy period is in effect.

NRND: Not recommended for new designs. Device is in production to support existing customers, but TI does not recommend using this part in a new design.

PREVIEW: Device has been announced but is not in production. Samples may or may not be available.

OBSOLETE: TI has discontinued the production of the device.

(2) Eco Plan - The planned eco-friendly classification: Pb-Free (RoHS), Pb-Free (RoHS Exempt), or Green (RoHS & no Sb/Br) - please check <http://www.ti.com/productcontent> for the latest availability information and additional product content details.

TBD: The Pb-Free/Green conversion plan has not been defined.

Pb-Free (RoHS): TI's terms "Lead-Free" or "Pb-Free" mean semiconductor products that are compatible with the current RoHS requirements for all 6 substances, including the requirement that lead not exceed 0.1% by weight in homogeneous materials. Where designed to be soldered at high temperatures, TI Pb-Free products are suitable for use in specified lead-free processes.

Pb-Free (RoHS Exempt): This component has a RoHS exemption for either 1) lead-based flip-chip solder bumps used between the die and package, or 2) lead-based die adhesive used between the die and leadframe. The component is otherwise considered Pb-Free (RoHS compatible) as defined above.

Green (RoHS & no Sb/Br): TI defines "Green" to mean Pb-Free (RoHS compatible), and free of Bromine (Br) and Antimony (Sb) based flame retardants (Br or Sb do not exceed 0.1% by weight in homogeneous material)

(3) MSL, Peak Temp. -- The Moisture Sensitivity Level rating according to the JEDEC industry standard classifications, and peak solder temperature.

(4) There may be additional marking, which relates to the logo, the lot trace code information, or the environmental category on the device.

(5) Multiple Device Markings will be inside parentheses. Only one Device Marking contained in parentheses and separated by a "~" will appear on a device. If a line is indented then it is a continuation of the previous line and the two combined represent the entire Device Marking for that device.

Important Information and Disclaimer: The information provided on this page represents TI's knowledge and belief as of the date that it is provided. TI bases its knowledge and belief on information provided by third parties, and makes no representation or warranty as to the accuracy of such information. Efforts are underway to better integrate information from third parties. TI has taken and continues to take reasonable steps to provide representative and accurate information but may not have conducted destructive testing or chemical analysis on incoming materials and chemicals. TI and TI suppliers consider certain information to be proprietary, and thus CAS numbers and other limited information may not be available for release.

In no event shall TI's liability arising out of such information exceed the total purchase price of the TI part(s) at issue in this document sold by TI to Customer on an annual basis.

TAPE AND REEL INFORMATION

REEL DIMENSIONS

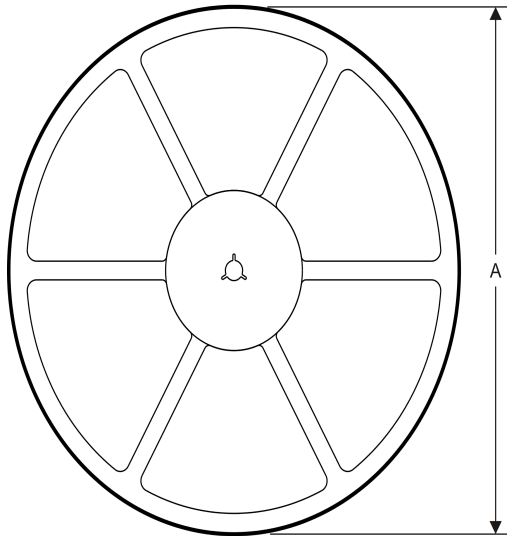

TAPE DIMENSIONS



A0	Dimension designed to accommodate the component width
B0	Dimension designed to accommodate the component length
K0	Dimension designed to accommodate the component thickness
W	Overall width of the carrier tape
P1	Pitch between successive cavity centers

TAPE AND REEL INFORMATION

*All dimensions are nominal

Device	Package Type	Package Drawing	Pins	SPQ	Reel Diameter (mm)	Reel Width W1 (mm)	A0 (mm)	B0 (mm)	K0 (mm)	P1 (mm)	W (mm)	Pin1 Quadrant
TUSB2551ARGTR	QFN	RGT	16	3000	330.0	12.4	3.3	3.3	1.0	8.0	12.0	Q2

TAPE AND REEL BOX DIMENSIONS



*All dimensions are nominal

Device	Package Type	Package Drawing	Pins	SPQ	Length (mm)	Width (mm)	Height (mm)
TUSB2551ARGTR	QFN	RGT	16	3000	346.0	346.0	35.0

PW (R-PDSO-G16)

PLASTIC SMALL OUTLINE



4040064-4/G 02/11

- NOTES:
- A. All linear dimensions are in millimeters. Dimensioning and tolerancing per ASME Y14.5M-1994.
 - B. This drawing is subject to change without notice.
 -  Body length does not include mold flash, protrusions, or gate burrs. Mold flash, protrusions, or gate burrs shall not exceed 0,15 each side.
 -  Body width does not include interlead flash. Interlead flash shall not exceed 0,25 each side.
 - E. Falls within JEDEC MO-153

RGT (S-PVQFN-N16)

PLASTIC QUAD FLATPACK NO-LEAD

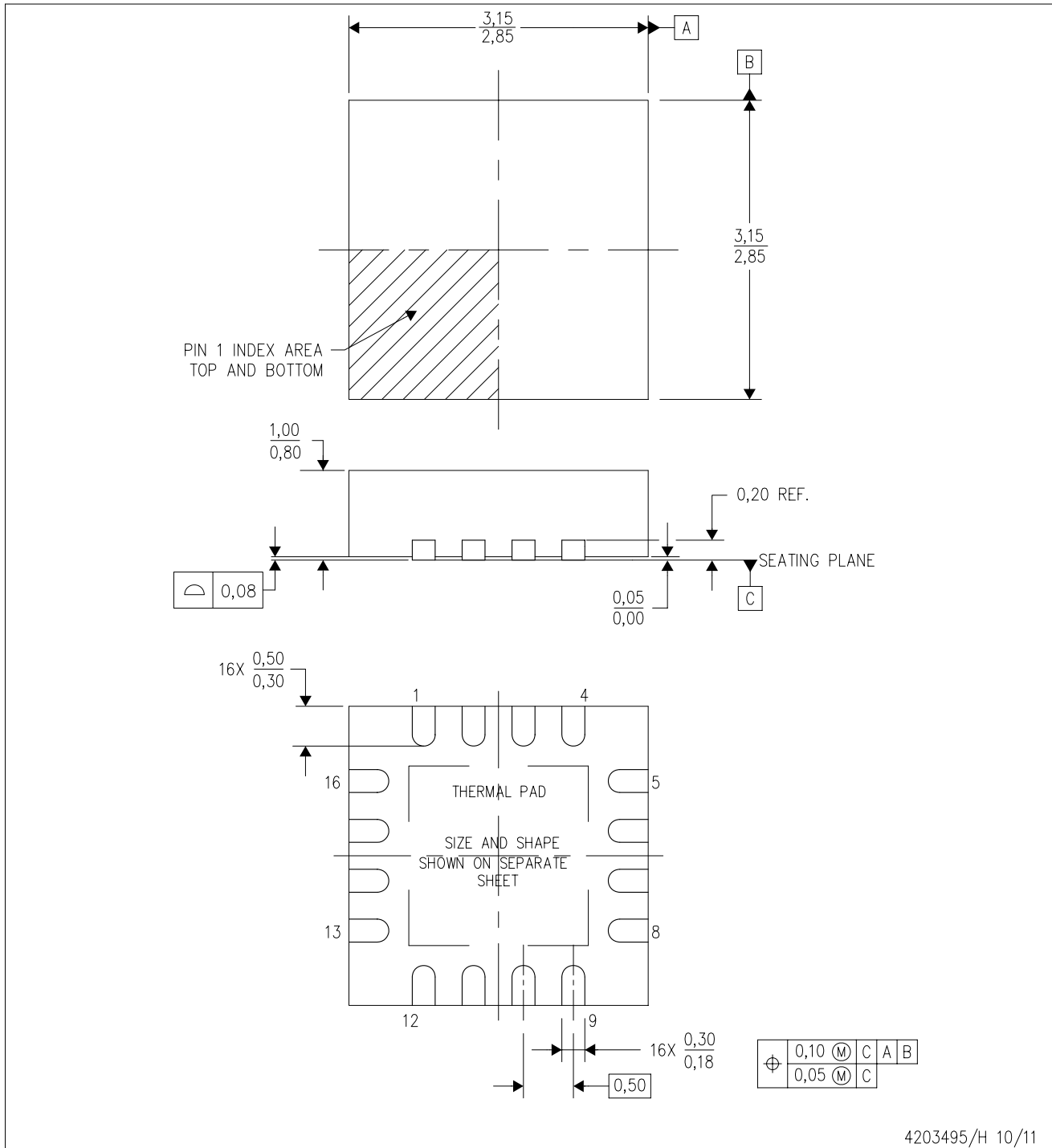

4203495/H 10/11

- NOTES:
- All linear dimensions are in millimeters. Dimensioning and tolerancing per ASME Y14.5M-1994.
 - This drawing is subject to change without notice.
 - Quad Flatpack, No-leads (QFN) package configuration.
 - The package thermal pad must be soldered to the board for thermal and mechanical performance.
 - See the additional figure in the Product Data Sheet for details regarding the exposed thermal pad features and dimensions.
 - Falls within JEDEC MO-220.

THERMAL PAD MECHANICAL DATA

RGT (S-PVQFN-N16)

PLASTIC QUAD FLATPACK NO-LEAD

THERMAL INFORMATION

This package incorporates an exposed thermal pad that is designed to be attached directly to an external heatsink. The thermal pad must be soldered directly to the printed circuit board (PCB). After soldering, the PCB can be used as a heatsink. In addition, through the use of thermal vias, the thermal pad can be attached directly to the appropriate copper plane shown in the electrical schematic for the device, or alternatively, can be attached to a special heatsink structure designed into the PCB. This design optimizes the heat transfer from the integrated circuit (IC).

For information on the Quad Flatpack No-Lead (QFN) package and its advantages, refer to Application Report, QFN/SON PCB Attachment, Texas Instruments Literature No. SLUA271. This document is available at www.ti.com.

The exposed thermal pad dimensions for this package are shown in the following illustration.

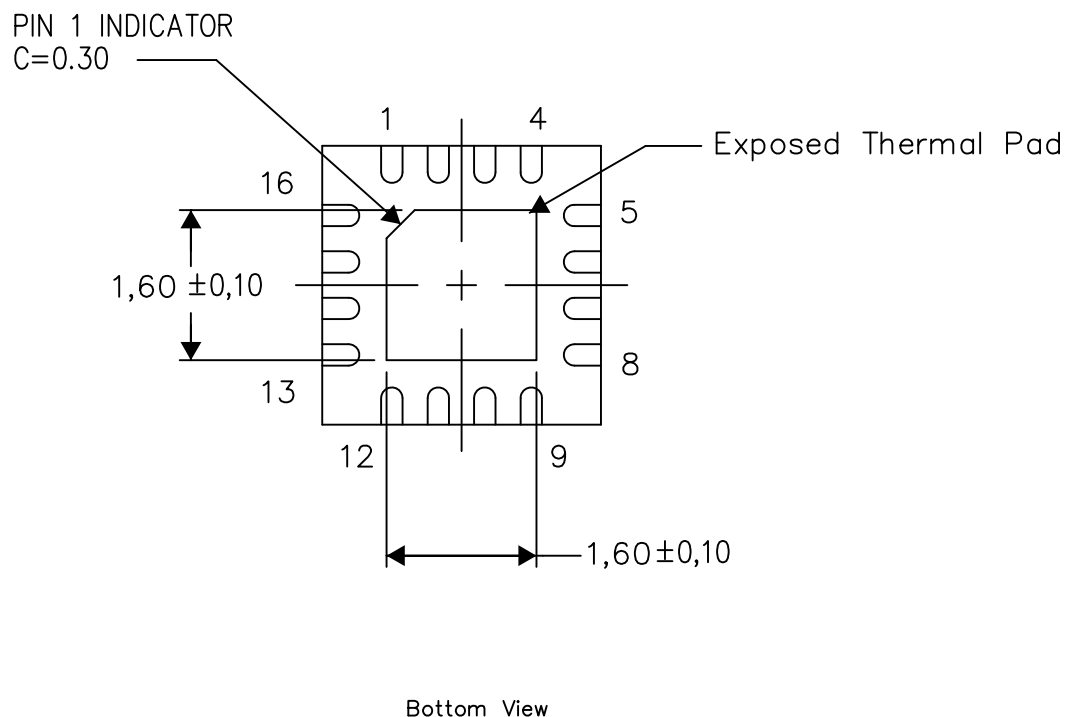

Exposed Thermal Pad Dimensions

4206349-3/S 04/13

NOTE: All linear dimensions are in millimeters

RGT (S-PVQFN-N16)

PLASTIC QUAD FLATPACK NO-LEAD

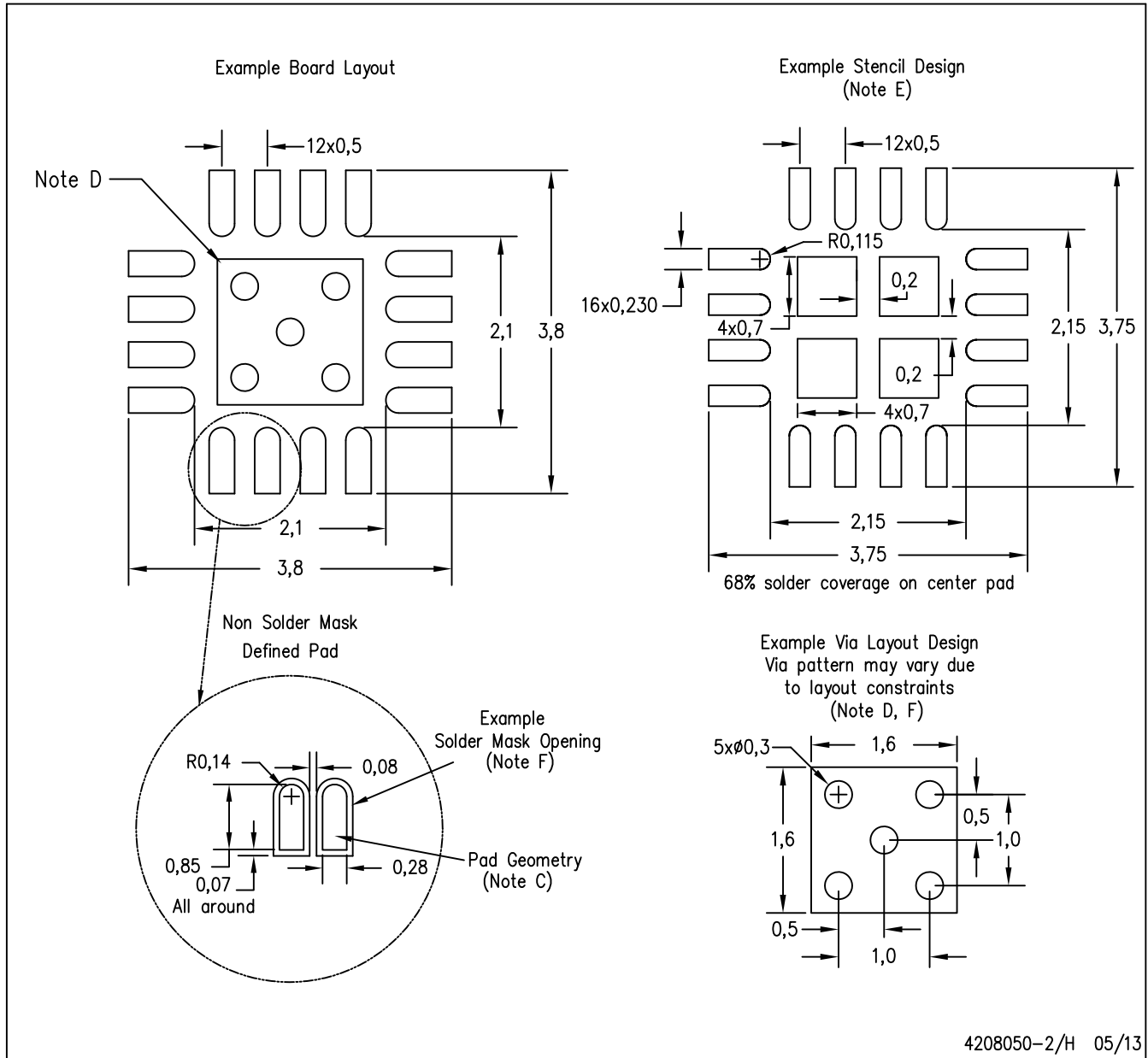

- NOTES:
- A. All linear dimensions are in millimeters.
 - B. This drawing is subject to change without notice.
 - C. Publication IPC-7351 is recommended for alternate designs.
 - D. This package is designed to be soldered to a thermal pad on the board. Refer to Application Note, QFN/SON PCB Attachment, Texas Instruments Literature No. SLUA271, and also the Product Data Sheets for specific thermal information, via requirements, and recommended board layout. These documents are available at www.ti.com <<http://www.ti.com>>.
 - E. Laser cutting apertures with trapezoidal walls and also rounding corners will offer better paste release. Customers should contact their board assembly site for stencil design recommendations. Refer to IPC 7525 for stencil design considerations.
 - F. Customers should contact their board fabrication site for minimum solder mask web tolerances between signal pads.

IMPORTANT NOTICE

Texas Instruments Incorporated and its subsidiaries (TI) reserve the right to make corrections, enhancements, improvements and other changes to its semiconductor products and services per JESD46, latest issue, and to discontinue any product or service per JESD48, latest issue. Buyers should obtain the latest relevant information before placing orders and should verify that such information is current and complete. All semiconductor products (also referred to herein as "components") are sold subject to TI's terms and conditions of sale supplied at the time of order acknowledgment.

TI warrants performance of its components to the specifications applicable at the time of sale, in accordance with the warranty in TI's terms and conditions of sale of semiconductor products. Testing and other quality control techniques are used to the extent TI deems necessary to support this warranty. Except where mandated by applicable law, testing of all parameters of each component is not necessarily performed.

TI assumes no liability for applications assistance or the design of Buyers' products. Buyers are responsible for their products and applications using TI components. To minimize the risks associated with Buyers' products and applications, Buyers should provide adequate design and operating safeguards.

TI does not warrant or represent that any license, either express or implied, is granted under any patent right, copyright, mask work right, or other intellectual property right relating to any combination, machine, or process in which TI components or services are used. Information published by TI regarding third-party products or services does not constitute a license to use such products or services or a warranty or endorsement thereof. Use of such information may require a license from a third party under the patents or other intellectual property of the third party, or a license from TI under the patents or other intellectual property of TI.

Reproduction of significant portions of TI information in TI data books or data sheets is permissible only if reproduction is without alteration and is accompanied by all associated warranties, conditions, limitations, and notices. TI is not responsible or liable for such altered documentation. Information of third parties may be subject to additional restrictions.

Resale of TI components or services with statements different from or beyond the parameters stated by TI for that component or service voids all express and any implied warranties for the associated TI component or service and is an unfair and deceptive business practice. TI is not responsible or liable for any such statements.

Buyer acknowledges and agrees that it is solely responsible for compliance with all legal, regulatory and safety-related requirements concerning its products, and any use of TI components in its applications, notwithstanding any applications-related information or support that may be provided by TI. Buyer represents and agrees that it has all the necessary expertise to create and implement safeguards which anticipate dangerous consequences of failures, monitor failures and their consequences, lessen the likelihood of failures that might cause harm and take appropriate remedial actions. Buyer will fully indemnify TI and its representatives against any damages arising out of the use of any TI components in safety-critical applications.

In some cases, TI components may be promoted specifically to facilitate safety-related applications. With such components, TI's goal is to help enable customers to design and create their own end-product solutions that meet applicable functional safety standards and requirements. Nonetheless, such components are subject to these terms.

No TI components are authorized for use in FDA Class III (or similar life-critical medical equipment) unless authorized officers of the parties have executed a special agreement specifically governing such use.

Only those TI components which TI has specifically designated as military grade or "enhanced plastic" are designed and intended for use in military/aerospace applications or environments. Buyer acknowledges and agrees that any military or aerospace use of TI components which have **not** been so designated is solely at the Buyer's risk, and that Buyer is solely responsible for compliance with all legal and regulatory requirements in connection with such use.

TI has specifically designated certain components as meeting ISO/TS16949 requirements, mainly for automotive use. In any case of use of non-designated products, TI will not be responsible for any failure to meet ISO/TS16949.

Products

Audio	www.ti.com/audio
Amplifiers	amplifier.ti.com
Data Converters	dataconverter.ti.com
DLP® Products	www.dlp.com
DSP	dsp.ti.com
Clocks and Timers	www.ti.com/clocks
Interface	interface.ti.com
Logic	logic.ti.com
Power Mgmt	power.ti.com
Microcontrollers	microcontroller.ti.com
RFID	www.ti-rfid.com
OMAP Applications Processors	www.ti.com/omap
Wireless Connectivity	www.ti.com/wirelessconnectivity

Applications

Automotive and Transportation	www.ti.com/automotive
Communications and Telecom	www.ti.com/communications
Computers and Peripherals	www.ti.com/computers
Consumer Electronics	www.ti.com/consumer-apps
Energy and Lighting	www.ti.com/energy
Industrial	www.ti.com/industrial
Medical	www.ti.com/medical
Security	www.ti.com/security
Space, Avionics and Defense	www.ti.com/space-avionics-defense
Video and Imaging	www.ti.com/video

TI E2E Community

e2e.ti.com