

10-Bit, 40-MSPS ANALOG-TO-DIGITAL CONVERTER WITH PGA AND CLAMP

FEATURES

- Analog Supply 3 V
- Digital Supply 3 V
- Configurable Input Functions:
 - Single-Ended
 - Single-Ended With Analog Clamp
 - Single-Ended With Programmable Digital Clamp
 - Differential
- Built-In Programmable Gain Amplifier (PGA)
- Differential Nonlinearity: ± 0.45 LSB
- Signal-to-Noise: 60 dB Typ $f_{(IN)}$ at 4.8 MHz
- Spurious Free Dynamic Range: 72 dB
- Adjustable Internal Voltage Reference
- Unsigned Binary/2s Complement Output
- Out-of-Range Indicator
- Power-Down Mode

APPLICATIONS

- Video/CCD Imaging
- Communications
- Set-Top-Box
- Medical

DESCRIPTION

The THS1041 is a CMOS, low power, 10-bit, 40 MSPS analog-to-digital converter (ADC) that operates from a single 3-V supply. The THS1041 has been designed to give circuit developers flexibility. The analog input to the THS1041 can be either single-ended or differential. This device has a built-in clamp amplifier whose clamp input level can be driven from an external dc source or from an internal high-precision 10-bit digital clamp level programmable via an internal CLAMP register. A 3-bit PGA is included to maintain SNR for small signals. The THS1041 provides a wide selection of voltage

references to match the user's design requirements. For more design flexibility, the internal reference can be bypassed to use an external reference to suit the dc accuracy and temperature drift requirements of the application. The out-of-range output indicates any out-of-range condition in THS1041's input signal. The format of the digital output can be coded in either unsigned binary or 2s complement.

The speed, resolution, and single-supply operation of the THS1041 are suited to applications in set-top-box (STB), video, multimedia, imaging, high-speed acquisition, and communications. The built-in clamp function allows dc restoration of a video signal and is suitable for video applications. The speed and resolution ideally suit charge-couple device (CCD) input systems such as color scanners, digital copiers, digital cameras, and camcorders. A wide input voltage range allows the THS1041 to be applied in both imaging and communications systems.

The THS1041C is characterized for operation from 0°C to 70°C, while the THS1041I is characterized for operation from –40°C to 85°C.

**28-PIN TSSOP/SOIC PACKAGE
(TOP VIEW)**

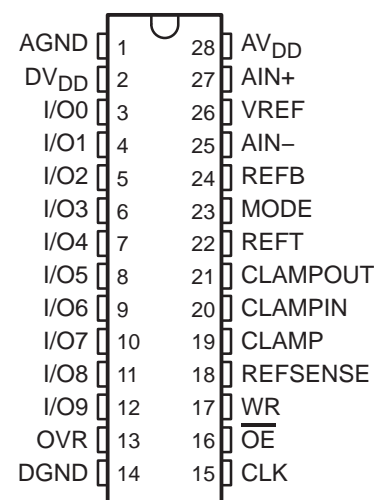

Please be aware that an important notice concerning availability, standard warranty, and use in critical applications of Texas Instruments semiconductor products and disclaimers thereto appears at the end of this data sheet.

AVAILABLE OPTIONS

PRODUCT	PACKAGE LEAD	PACKAGE DESIGNATOR†	SPECIFIED TEMPERATURE RANGE	PACKAGE MARKINGS	ORDERING NUMBER	TRANSPORT MEDIA, QUANTITY
THS1041C	TSSOP-28	PW	0°C to 70°C	TH1041	THS1041CPW	Tube, 50
						THS1041CPWR
THS1041I	TSSOP-28	PW	-40°C to 85°C	TJ1041	THS1041IPW	Tube, 50
						THS1041IPWR
THS1041C	SOP-28	DW	0°C to 70°C	TH1041	THS1041CDW	Tube, 20
						THS1041CDWR
THS1041I	SOP-28	DW	-40°C to 85°C	TJ1041	THS1041IDW	Tube, 20
						THS1041IDWR

† For the most current specification and package information, refer to the TI web site at www.ti.com.

functional block diagram

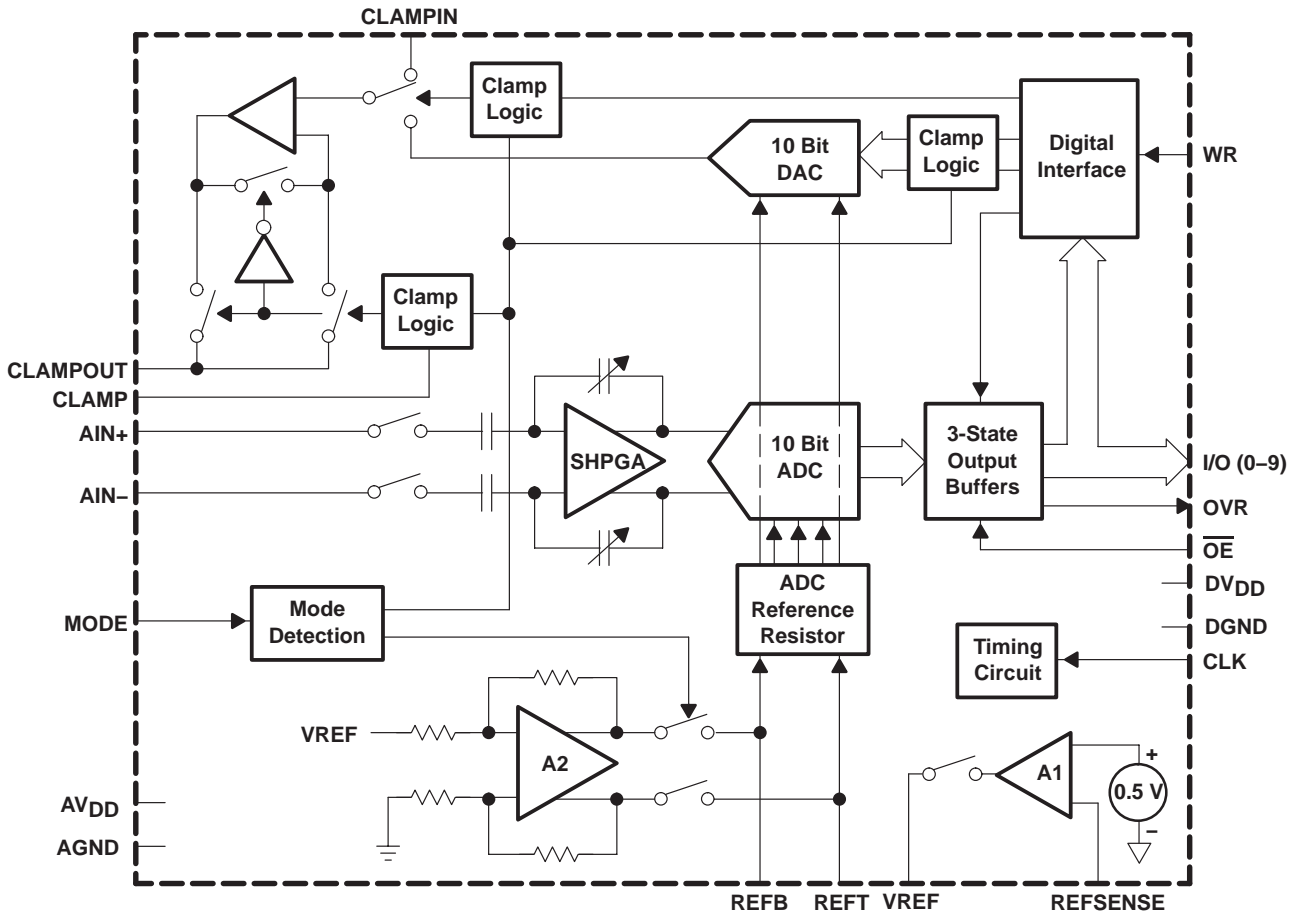

NOTE: A1 – Internal bandgap reference
 A2 – Internal ADC reference generator

Terminal Functions

TERMINAL NAME	NO.	I/O	DESCRIPTION
AGND	1	I	Analog ground
AIN+	27	I	Positive analog input
AIN-	25	I	Negative analog input
AVDD	28	I	Analog supply
CLAMP	19	I	High to enable clamp mode, low to disable clamp mode
CLAMPIN	20	I	Connect to an external analog clamp reference input.
CLAMPOUT	21	O	The CLAMPOUT pin can provide a dc restoration or a bias source function (see AC reference generation section). If neither function is required then the clamp can be disabled to save power (see power management section).
CLK	15	I	Clock input
DGND	14	I	Digital ground
DVDD	2	I	Digital supply
I/O0	3	I/O	Digital I/O bit 0 (LSB)
I/O1	4		Digital I/O bit 1
I/O2	5		Digital I/O bit 2
I/O3	6		Digital I/O bit 3
I/O4	7		Digital I/O bit 4
I/O5	8		Digital I/O bit 5
I/O6	9		Digital I/O bit 6
I/O7	10		Digital I/O bit 7
I/O8	11		Digital I/O bit 8
I/O9	12		Digital I/O bit 9 (MSB)
MODE	23	I	Operating mode select (AGND, AVDD/2, AVDD)
\overline{OE}	16	I	High to high-impedance state the data bus, low to enable the data bus
OVR	13	O	Out-of-range indicator
REFB	24	I/O	Bottom ADC reference voltage
REFSENSE	18	I	VREF mode control
REFT	22	I/O	Top ADC reference voltage
VREF	26	I/O	Internal or external reference
WR	17	I	Write strobe

absolute maximum ratings over operating free-air temperature (unless otherwise noted)†

Supply voltage range: AV _{DD} to AGND, DV _{DD} to DGND	-0.3 V to 4 V
AGND to DGND	-0.3 V to 0.3 V
AV _{DD} to DV _{DD}	-4 V to 4 V
MODE input voltage range, MODE to AGND	-0.3 V to AV _{DD} + 0.3 V
Reference voltage input range, REFT, REFB, to AGND	-0.3 V to AV _{DD} + 0.3 V
Analog input voltage range, AIN to AGND	-0.3 V to AV _{DD} + 0.3 V
Reference input voltage range, VREF to AGND	-0.3 V to AV _{DD} + 0.3 V
Reference output voltage range, VREF to AGND	-0.3 V to AV _{DD} + 0.3 V
Clock input voltage range, CLK to AGND	-0.3 V to AV _{DD} + 0.3 V
Digital input voltage range, digital input to DGND	-0.3 V to DV _{DD} + 0.3 V
Digital output voltage range, digital output to DGND	-0.3 V to DV _{DD} + 0.3 V
Operating junction temperature range, T _J	0°C to 150°C
Storage temperature range, T _{stg}	-65°C to 150°C
Lead temperature 1,6 mm (1/16 in) from case for 10 seconds	300°C

† Stresses beyond those listed under “absolute maximum ratings” may cause permanent damage to the device. These are stress ratings only, and functional operation of the device at these or any other conditions beyond those indicated under “recommended operating conditions” is not implied. Exposure to absolute-maximum-rated conditions for extended periods may affect device reliability.

recommended operating conditions

over operating free-air temperature range T_A, (unless otherwise noted)

PARAMETER	CONDITION	MIN	NOM	MAX	UNIT	
Power Supply						
Supply voltage	AV _{DD} , DV _{DD}	3	3	3.6	V	
Analog and Reference Inputs						
VREF input voltage	V _I (VREF)	REFSENSE = AV _{DD}	0.5	1	V	
REFT input voltage	V _I (REFT)	MODE = AGND	1.75	2	V	
REFB input voltage	V _I (REFB)	MODE = AGND	1	1.25	V	
Reference input voltage	V _I (REFT) – V _I (REFB)	MODE = AGND	0.5	1	V	
Reference common mode voltage	(V _I (REFT) + V _I (REFB))/2	MODE = AGND	(AV _{DD} /2) – 0.05	(AV _{DD} /2) + 0.05	V	
Analog input voltage differential (see Note 1)	V _I (AIN)	REFSENSE = AGND	-1	1	V	
		REFSENSE = VREF	-0.5	0.5	V	
Analog input capacitance, C _I				10	pF	
Clock input (see Note 2)		0		AV _{DD}	V	
Clamp input voltage	V _I (CLAMPIN)	0.1		AV _{DD} – 0.1	V	
Digital Outputs						
Maximum digital output load resistance	R _L	100			kΩ	
Maximum digital output load capacitance	C _L			10	pF	
Digital Inputs						
High-level input voltage, V _{IH}		2.4		DV _{DD}	V	
Low-level input voltage, V _{IL}		DGND		0.8	V	
Clock frequency (see Note 3)	t _c	f(CLK) = 5 MHz to 40 MHz	25	200	nS	
Clock pulse duration	t _w (CKL), t _w (CKH)	f(CLK) = 40 MHz	11.25	12.5	13.75	nS
Operating free-air temperature, T _A		THS1041C	0	70	°C	
		THS1041I	-40	85		

NOTE 1: V_I(AIN) is AIN+ – AIN– range, based on V_I(REFT) – V_I(REFB) = 1V. Varies proportional to the V_I(REFT) – V_I(REFB) value. Input common mode voltage is recommended to be AV_{DD}/2.

NOTE 2: The clock pin is referenced to AV_{SS} and powered by AV_{DD}.

NOTE 3: Clock frequency can be extended to this range without degradation of performance.

electrical characteristics

over recommended operating conditions, $AV_{DD} = 3\text{ V}$, $DV_{DD} = 3\text{ V}$, $f_s = 40\text{ MSPS}/50\%$ duty cycle, $MODE = AV_{DD}$ (internal reference), differential input range = 1 V_{pp} and 2 V_{pp} , $PGA = 1X$, $T_A = T_{min}$ to T_{max} (unless otherwise noted)

power supply

PARAMETER		TEST CONDITIONS	MIN	TYP	MAX	UNIT
AV_{DD}	Supply voltage		3	3	3.6	V
DV_{DD}			3	3	3.6	
I_{CC}	Operating supply current	See Note 4		34	42	mA
P_D	Power dissipation	See Note 4		103	125	mW
$P_D(\text{STBY})$	Standby power			75		μW
	Power up time for all references from standby, $t_{(PU)}$	10 μF bypass		770		μs
	Wake-up time, $t_{(WU)}$	See Note 5		45		μs

REFT, REFB internal ADC reference voltages outputs (MODE = AV_{DD} or $AV_{DD}/2$) (See Note 6)

PARAMETER		TEST CONDITIONS	MIN	TYP	MAX	UNIT
Reference voltage top, REFT	$V_{REF} = 0.5\text{ V}$	$AV_{DD} = 3\text{ V}$		1.75		V
	$V_{REF} = 1\text{ V}$			2		
Reference voltage bottom, REFB	$V_{REF} = 0.5\text{ V}$	$AV_{DD} = 3\text{ V}$		1.25		V
	$V_{REF} = 1\text{ V}$			1		
Input resistance between REFT and REFB			1.4	1.9	2.5	$\text{k}\Omega$

VREF (on-chip voltage reference generator)

PARAMETER	MIN	TYP	MAX	UNIT
Internal 0.5-V reference voltage ($REFSENSE = V_{REF}$)	0.45	0.5	0.55	V
Internal 1-V reference voltage ($REFSENSE = AGND$)	0.95	1	1.05	V
Reference input resistance ($REFSENSE = AV_{DD}$, $MODE = AV_{DD}/2$ or AV_{DD})	7	14	21	$\text{k}\Omega$

dc accuracy

PARAMETER	MIN	TYP	MAX	UNIT
Resolution		10		Bits
INL Integral nonlinearity (see definitions)	-1.5	± 0.75	1.5	LSB
DNL Differential nonlinearity (see definitions)	-0.9	± 0.3	1	LSB
Zero error (see definitions)	-1.5	0.7	1.5	%FSR
Full-scale error (see definitions)	-3	2.2	3	%FSR
Missing code	No missing code assured			

- NOTES:
- A -1 dBFS 10-KHz triangle wave is applied at A_{IN+} and A_{IN-} . Internal bandgap reference and ADC reference are enabled, CLAMPOUT is set to $AV_{DD}/2$. ADC conversions are taking place during power measurements at 40 MSPS. A CLAMPOUT load or V_{REF} load may result in additional current.
 - Wake-up time is from the power-down state to accurate ADC samples being taken and is specified for $MODE = AGND$ with external reference sources applied to the device at the time of release of power-down and an applied 40-MHz clock. Circuits that need to power up are the bandgap, bias generator, ADC, and SHPGA.
 - External reference values are listed in the *Recommended Operating Conditions Table*.

electrical characteristics

over recommended operating conditions, $AV_{DD} = 3\text{ V}$, $DV_{DD} = 3\text{ V}$, $f_s = 40\text{ MSPS}/50\%$ duty cycle, $MODE = AV_{DD}$ (internal reference), differential input range = 1 V_{pp} and 2 V_{pp}, $PGA = 1X$, $T_A = T_{min}$ to T_{max} (unless otherwise noted) (continued)

dynamic performance (ADC and PGA)

PARAMETER		TEST CONDITIONS	MIN	TYP	MAX	UNIT
ENOB	Effective number of bits	$f = 4.8\text{ MHz}$, -0.5 dBFS	8.8	9.6		Bits
		$f = 20\text{ MHz}$, -0.5 dBFS		9.5		
SFDR	Spurious free dynamic range	$f = 4.8\text{ MHz}$, -0.5 dBFS	60.5	72		dB
		$f = 20\text{ MHz}$, -0.5 dBFS		70		
THD	Total harmonic distortion	$f = 4.8\text{ MHz}$, -0.5 dBFS		-72.5	-61.3	dB
		$f = 20\text{ MHz}$, -0.5 dBFS		-71.6		
SNR	Signal-to-noise ratio	$f = 4.8\text{ MHz}$, -0.5 dBFS	55.7	60		dB
		$f = 20\text{ MHz}$, -0.5 dBFS		57		
SINAD	Signal-to-noise and distortion	$f = 4.8\text{ MHz}$, -0.5 dBFS	55.6	59.7		dB
		$f = 20\text{ MHz}$, -0.5 dBFS		59.6		
BW	Full power bandwidth (-3 dB)			900		MHz

PGA (See Note 7)

PARAMETER	MIN	TYP	MAX	UNIT
Gain range (linear scale)	0.5		4	V/V
Gain step size (linear scale)	0.485	0.5	0.515	V/V
Gain error (deviation from ideal, all gain settings)	-3%		3%	
Number of control bits		3		Bits

clamp amplifier and clamp DAC (See Note 8)

PARAMETER	MIN	TYP	MAX	UNIT
Resolution		10		Bits
DAC output range	REFB		REFT	V
DAC differential nonlinearity	-1		1	LSB
DAC integral nonlinearity	-3		3	LSB
Clamping analog output voltage range	0.1		$AV_{DD} - 0.1$	V
Clamping analog output voltage error	-40		40	mV
Clamping analog output bias voltage	$MODE = AV_{DD}$	$AV_{DD}/2 - 0.1$	$AV_{DD}/2 + 0.1$	mV

NOTES: 7. Gain settings increment by the gain step size for eight binary settings of 000 to 111 to correspond to the ideal gain range.

8. The CLAMP_{OUT} pin must see a load capacitance of at least 10 nF to ensure stability of the on-chip clamp buffer. When using the clamp for dc restoration, the signal coupling capacitor should be at least 10 nF. When using the clamp buffer as a dc biasing reference, CLAMP_{OUT} should be decoupled to analog ground through at least a 10-nF capacitor.

electrical characteristics

over recommended operating conditions, $AV_{DD} = 3\text{ V}$, $DV_{DD} = 3\text{ V}$, $f_s = 40\text{ MSPS}/50\%$ duty cycle, $MODE = AV_{DD}$ (internal reference), differential input range = 1 V_{pp} and 2 V_{pp} , $PGA = 1X$, $T_A = T_{min}$ to T_{max} (unless otherwise noted) (continued)

digital specifications

PARAMETER		MIN	NOM	MAX	UNIT
Digital Inputs					
V_{IH}	High-level input voltage	Clock input		$0.8 \times AV_{DD}$	V
		All other inputs		$0.8 \times DV_{DD}$	
V_{IL}	Low-level input voltage	Clock input		$0.2 \times AV_{DD}$	V
		All other inputs		$0.2 \times DV_{DD}$	
I_{IH}	High-level input current			1	μA
I_{IL}	Low-level input current			$ -1 $	μA
C_i	Input capacitance		5		pF
Digital Outputs					
V_{OH}	High-level output voltage	$I_{load} = 50\ \mu\text{A}$		$DV_{DD} - 0.4$	V
V_{OL}	Low-level output voltage	$I_{load} = 50\ \mu\text{A}$		0.4	V
	High impedance output current			± 1	μA
	Rise/fall time	$C_{load} = 15\text{ pF}$		3.5	ns
Clock Input					
t_c	Clock cycle	25		200	ns
$t_w(\text{CKH})$	Pulse duration, clock high	11.25		110	ns
$t_w(\text{CKL})$	Pulse duration, clock low	11.25		110	ns
	Clock duty cycle	45%	50%	55%	
$t_{d(o)}$	Clock to data valid, delay time		9.5	16	ns
	Pipeline latency		4		Cycles
$t_{d(\text{AP})}$	Aperture delay time		0.1		ns
	Aperture uncertainty (jitter)		1		ps

timing

PARAMETER		MIN	TYP	MAX	UNIT
$t_{d(\text{DZ})}$	Output disable to Hi-Z output, delay time	0		10	ns
$t_{d(\text{DEN})}$	Output enable to output valid, delay time	0		10	ns
$t_{d(\text{OEW})}$	Output disable to write enable, delay time	12			ns
$t_{d(\text{WOE})}$	Write disable to output enable, delay time	12			ns
$t_w(\text{WP})$	Write pulse duration	15			ns
t_{su}	Input data setup time	5			ns
t_h	Input data hold time	5			ns

PARAMETER MEASUREMENT INFORMATION

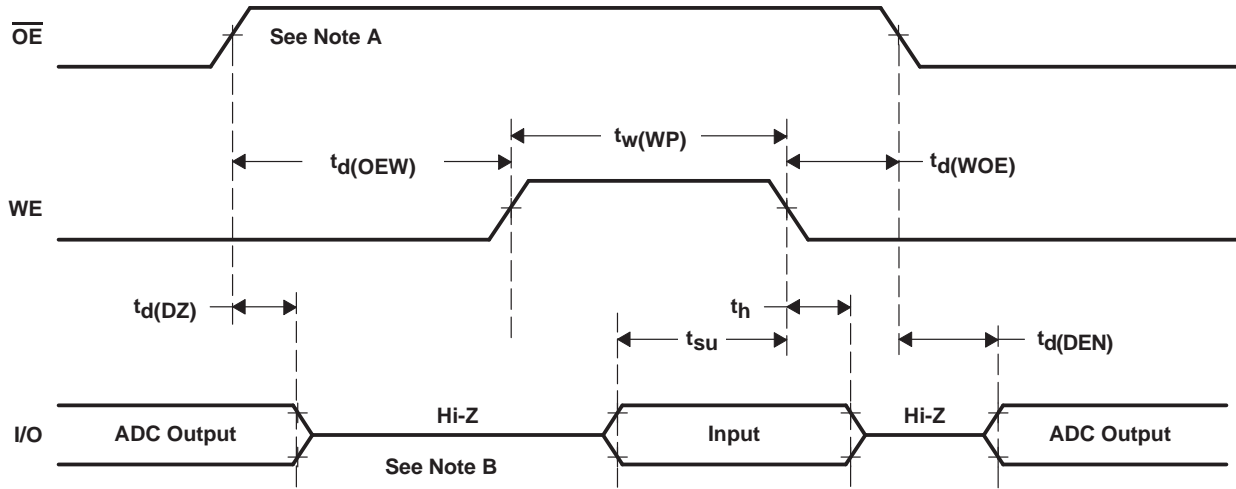

NOTE A: All timing measurements are based on 50% of edge transition.

NOTE B: Output data is converted ADC digital data. The input data is stored in the internal *write only* control registers.

Figure 1. Write Timing Diagram

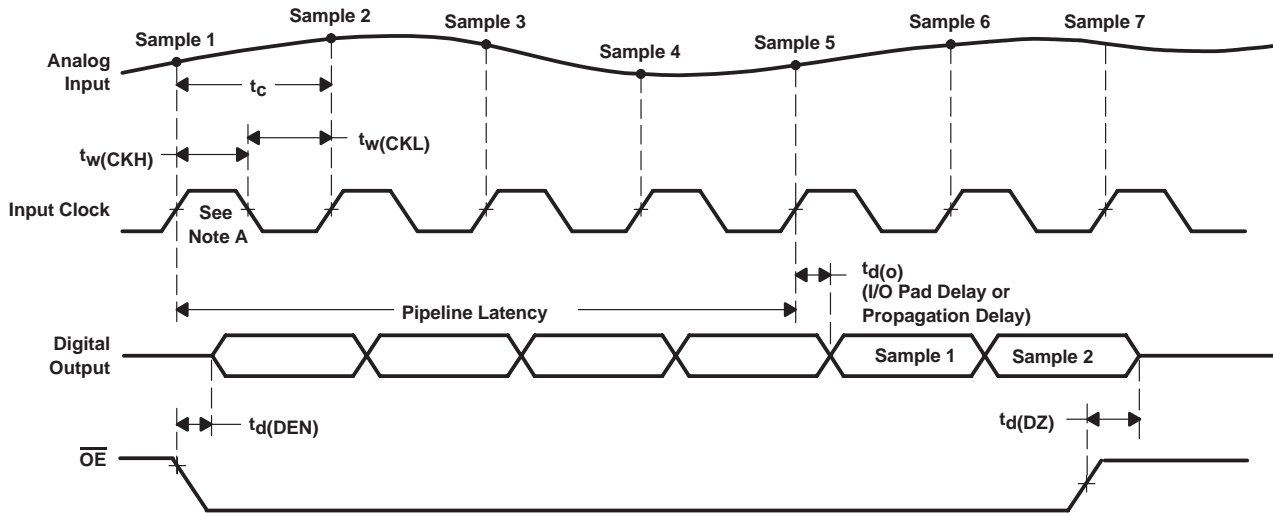

NOTE A: All timing measurements are based on 50% of edge transition.

Figure 2. Digital Output Timing Diagram

TYPICAL CHARACTERISTICS

DIFFERENTIAL NONLINEARITY
VS
INPUT CODE

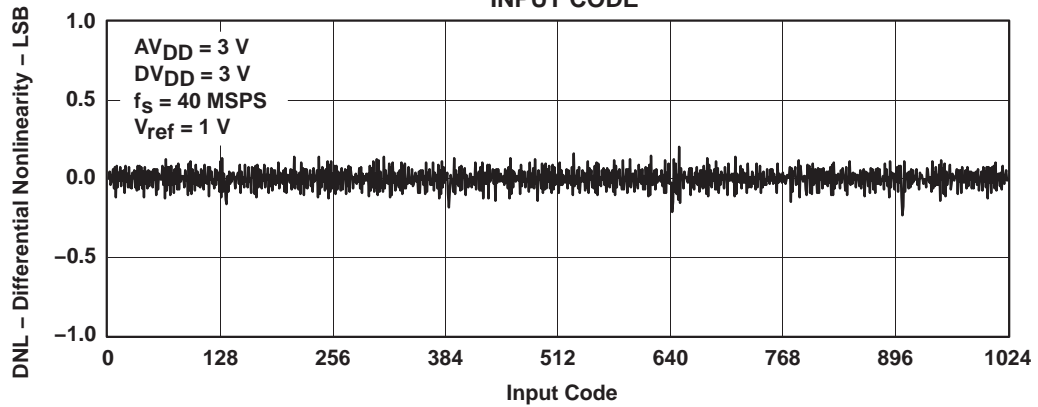

Figure 3

INTEGRAL NONLINEARITY
VS
INPUT CODE

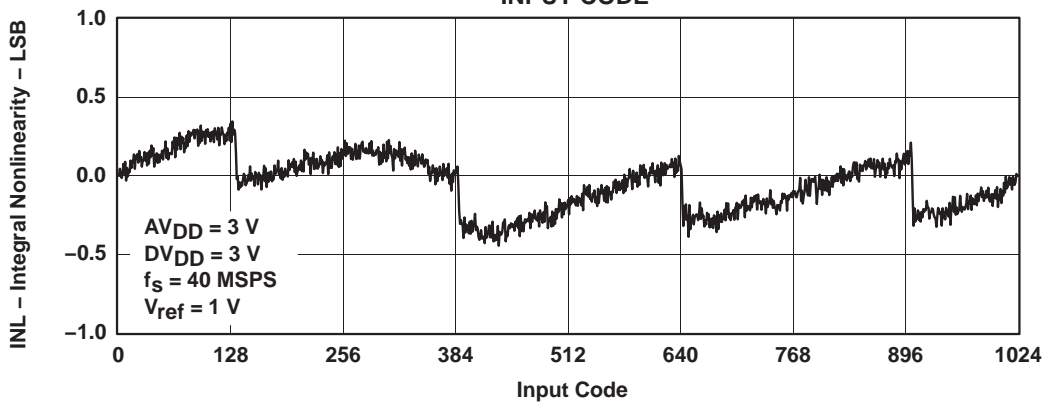

Figure 4

INTEGRAL NONLINEARITY
VS
INPUT CODE

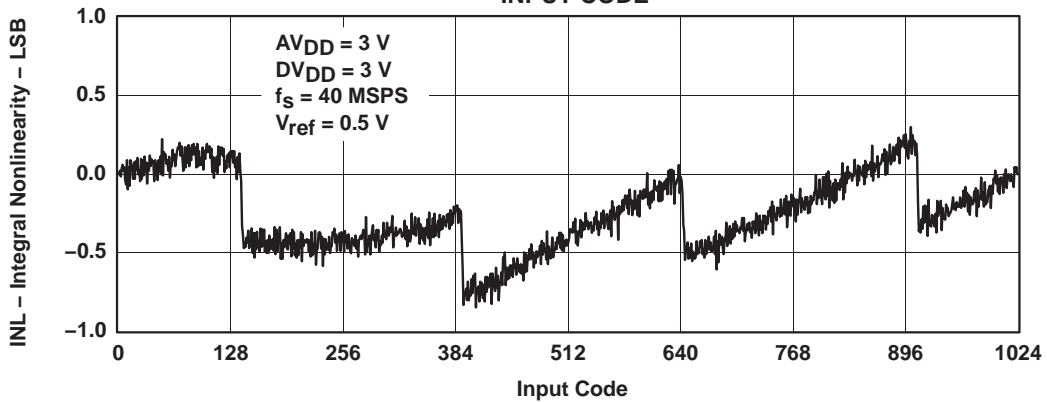

Figure 5

TYPICAL CHARACTERISTICS

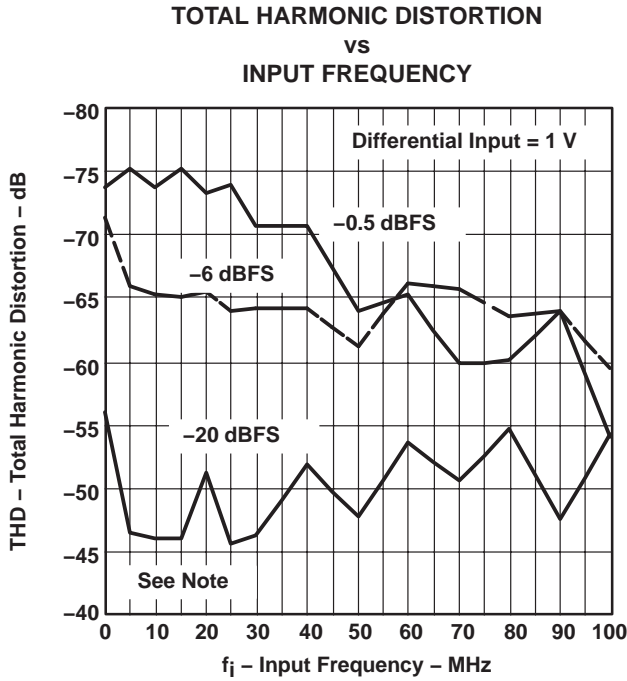

Figure 6

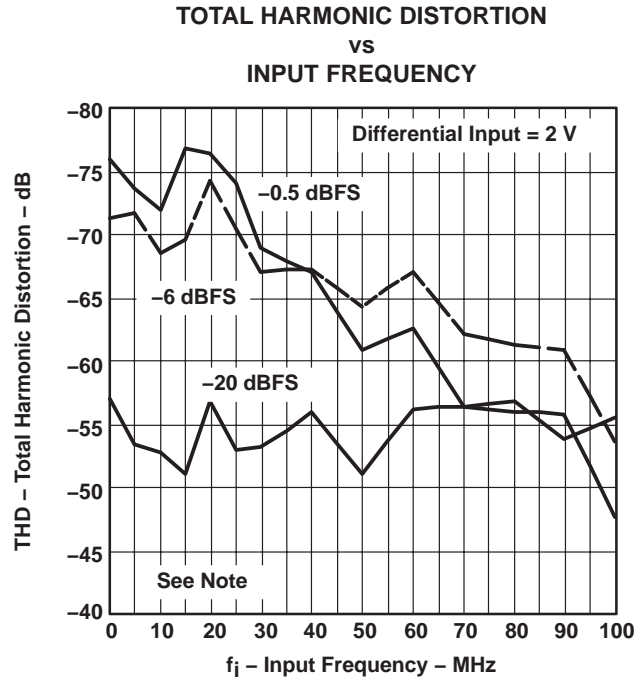

Figure 7

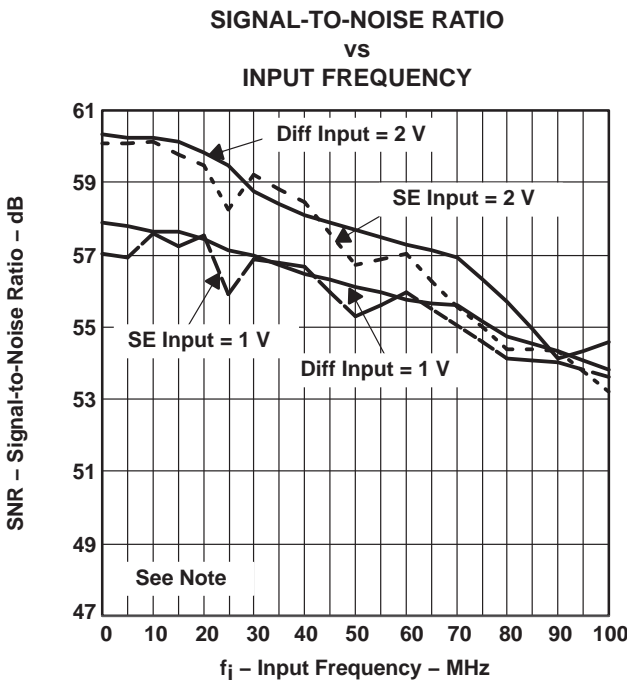

Figure 8

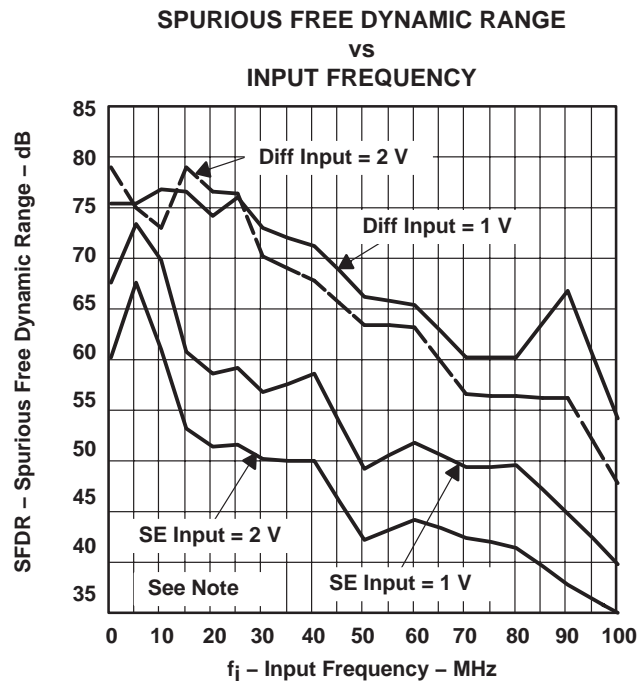

Figure 9

NOTE: $V_{DD} = DV_{DD} = 3 V$, $f_S = 40 \text{ MSPS}$, $PGA = 1$,
 Input series resistor = 25Ω ,
 2-V Input: Ext Ref, REFT = 2 V, REFB = 1 V, -0.5 dBFS
 1-V Input: Ext Ref, REFT = 1.75 V, REFB = 1.25 V, -0.5dBFS

20-pF capacitors AIN+ to AGND and AIN- to AGND,

TYPICAL CHARACTERISTICS

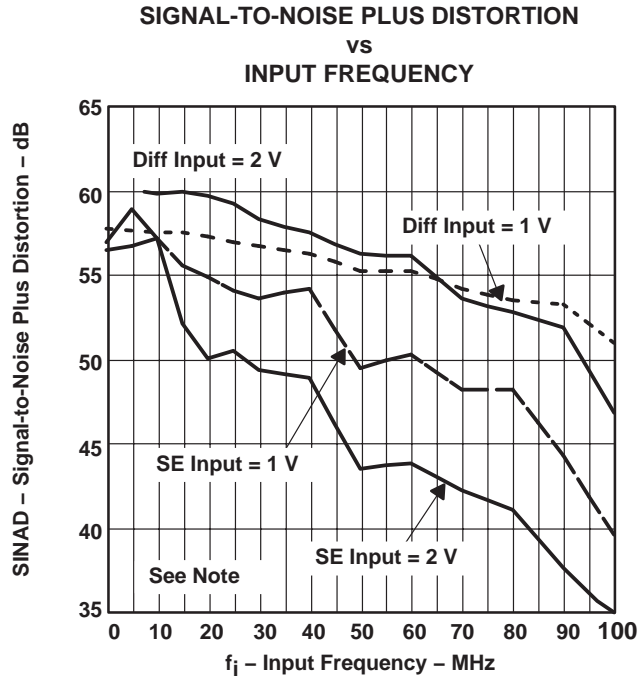

Figure 10

NOTE: $AV_{DD} = DV_{DD} = 3 V$, $f_S = 40 \text{ MSPS}$, $PGA = 1$,
Input series resistor = 25Ω ,
2-V Input: Ext Ref, REFT = 2 V, REFB = 1 V
1-V Input: Ext Ref, REFT = 1.75 V, REFB = 1.25 V

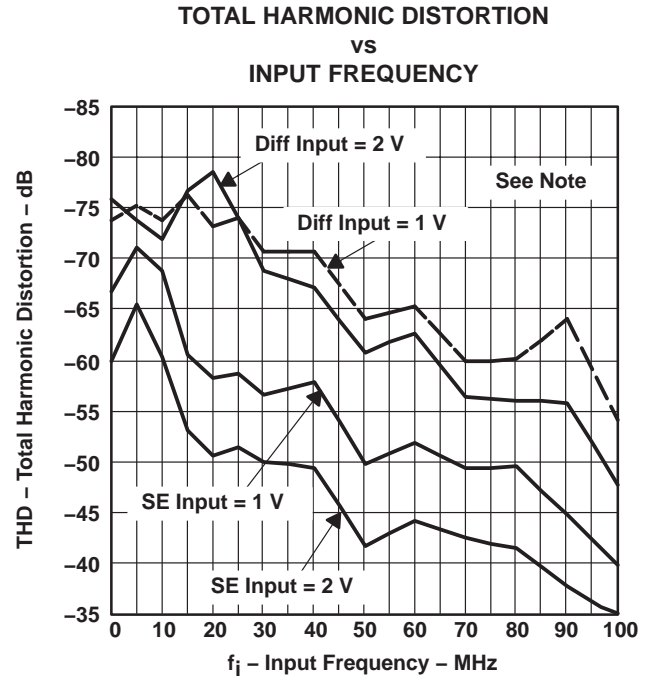

Figure 11

20-pF capacitors AIN+ to AGND and AIN- to AGND,

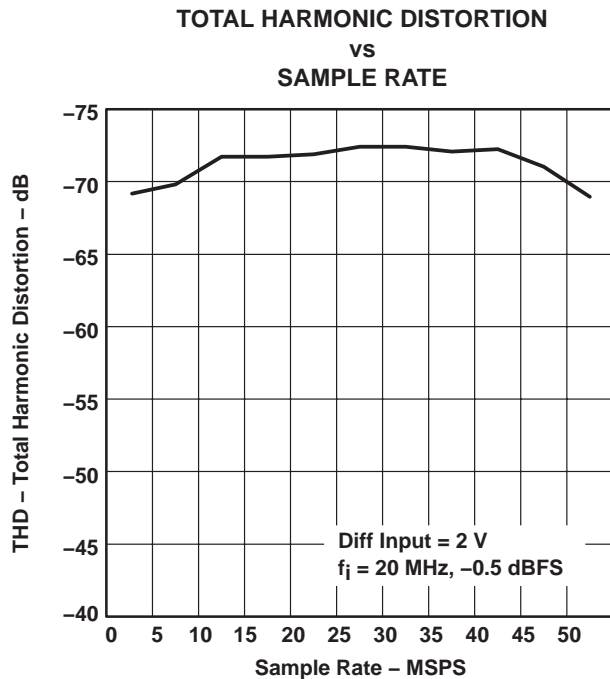

Figure 12

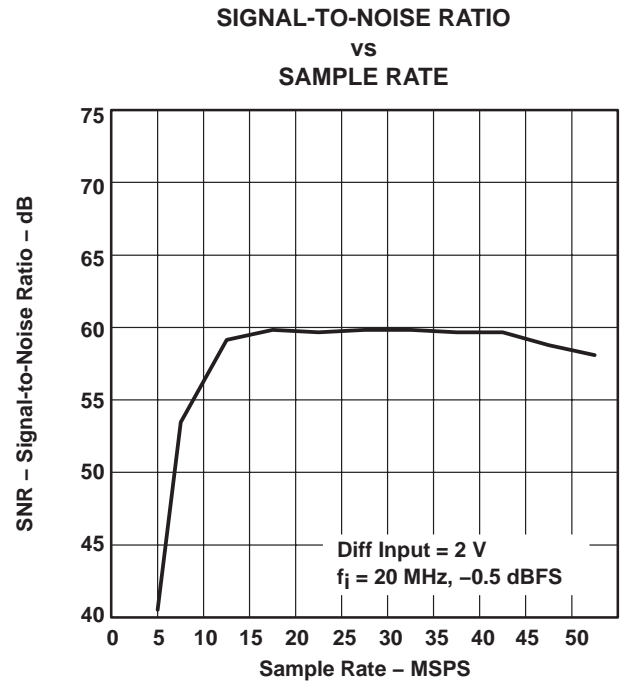

Figure 13

TYPICAL CHARACTERISTICS

SPURIOUS FREE DYNAMIC RANGE
vs
SUPPLY VOLTAGE

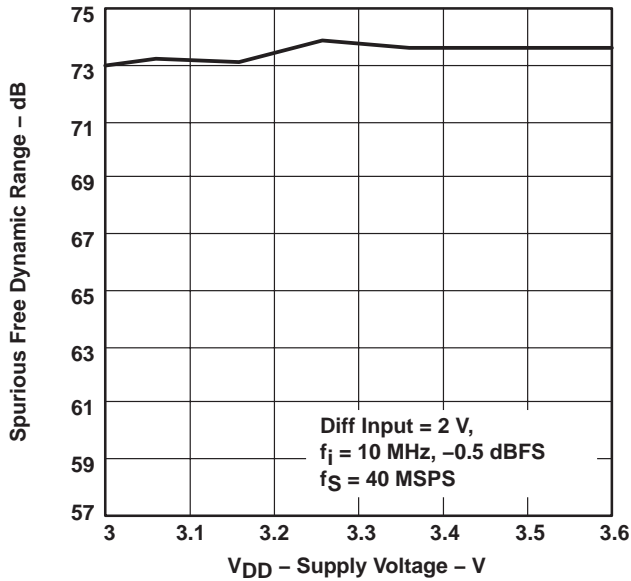

Figure 14

TOTAL HARMONIC DISTORTION
vs
SUPPLY VOLTAGE

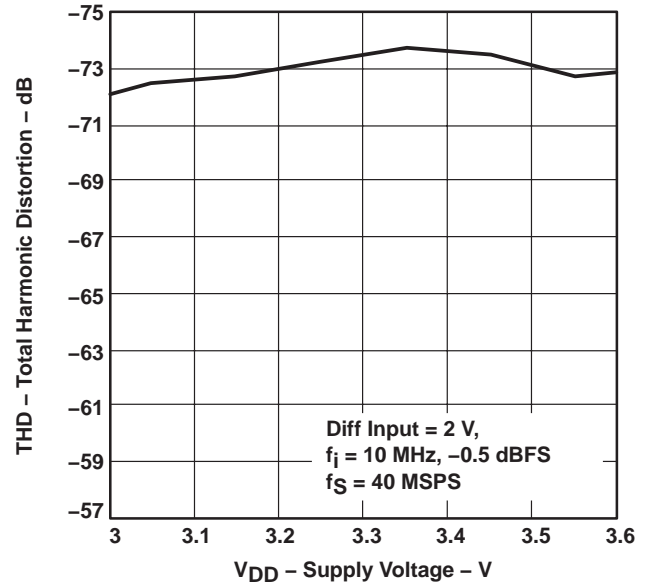

Figure 15

SIGNAL-TO-NOISE RATIO
vs
SUPPLY VOLTAGE

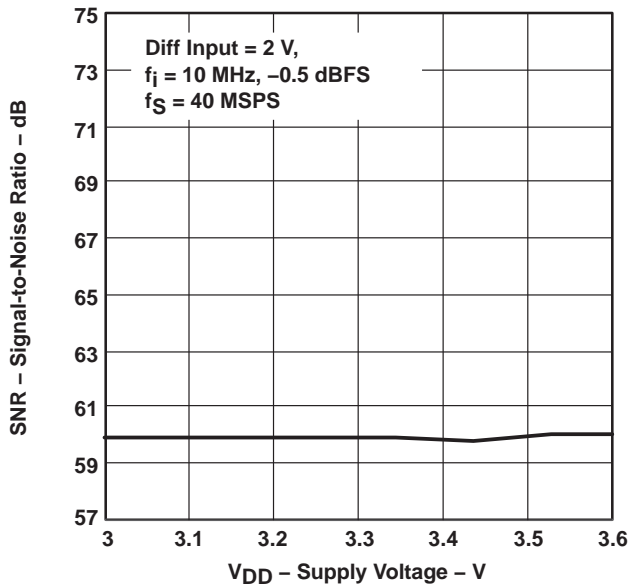

Figure 16

SIGNAL-TO-NOISE PLUS DISTORTION
vs
SUPPLY VOLTAGE

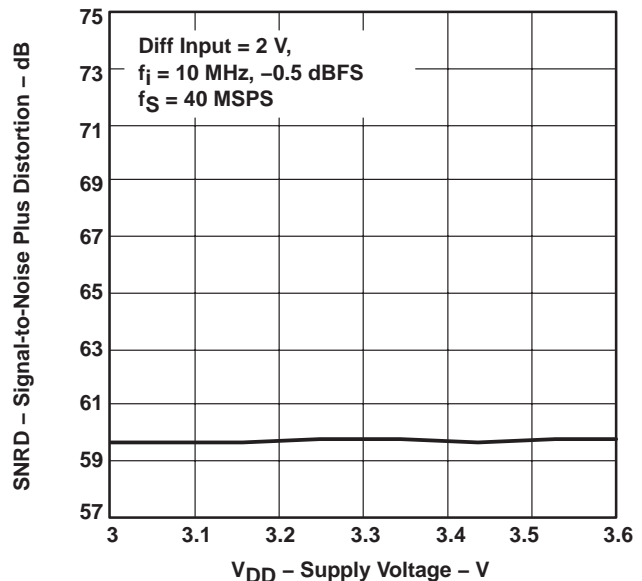
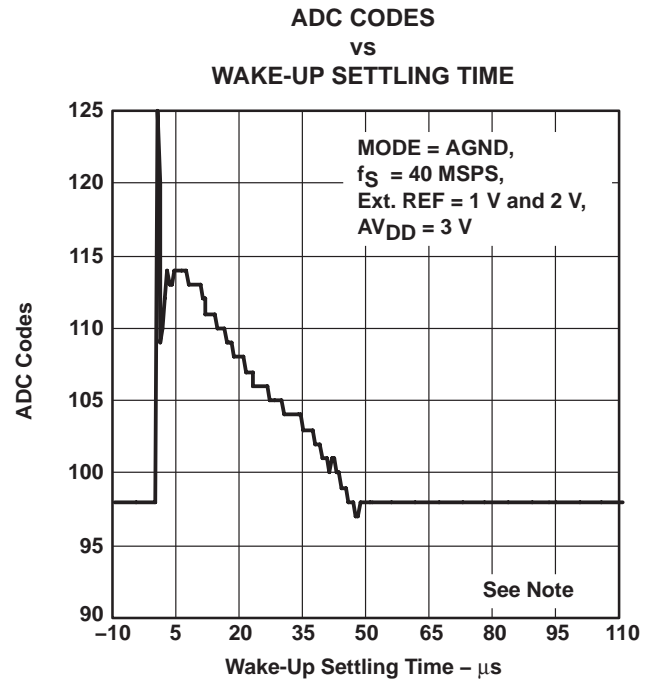
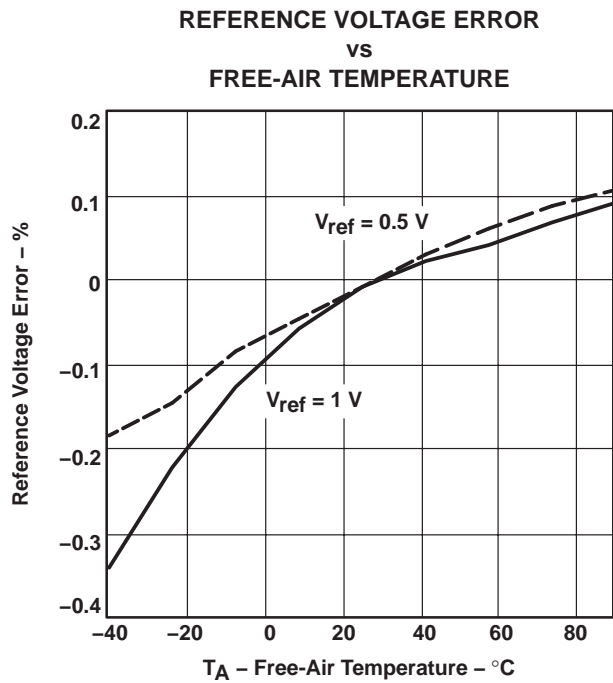
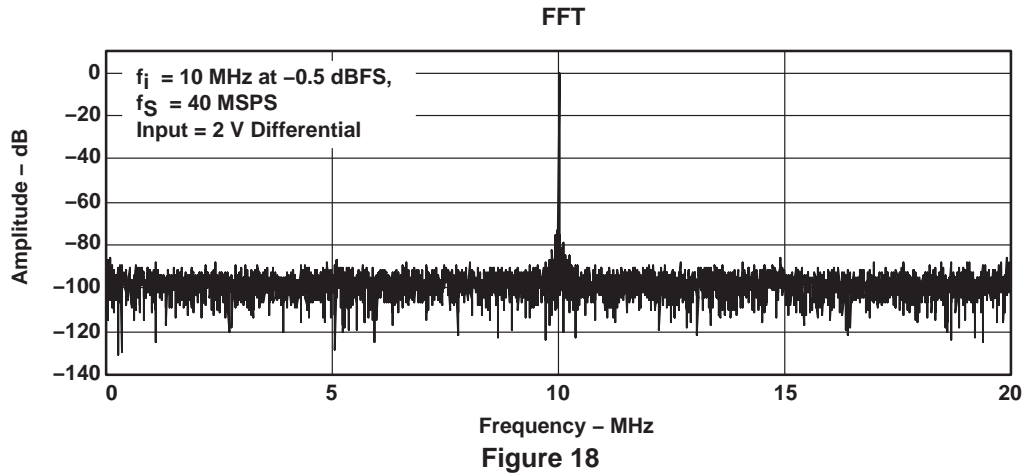

Figure 17

TYPICAL CHARACTERISTICS



NOTE: See wake-up time in definitions at the end of this data sheet.

TYPICAL CHARACTERISTICS

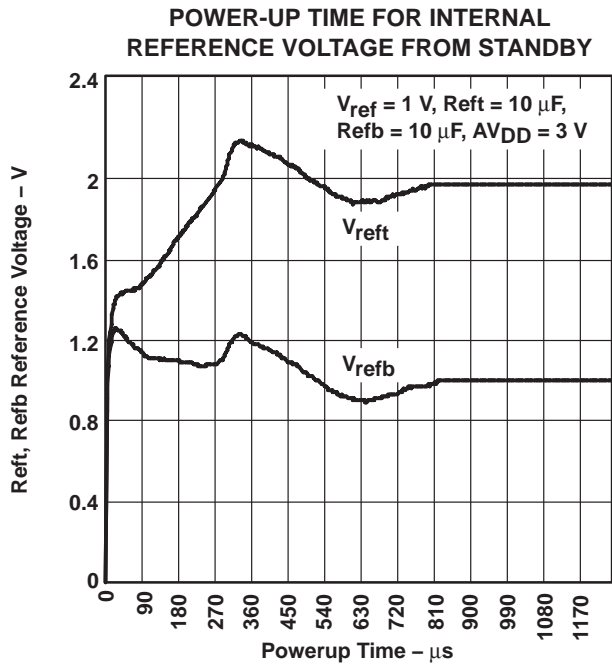

Figure 21

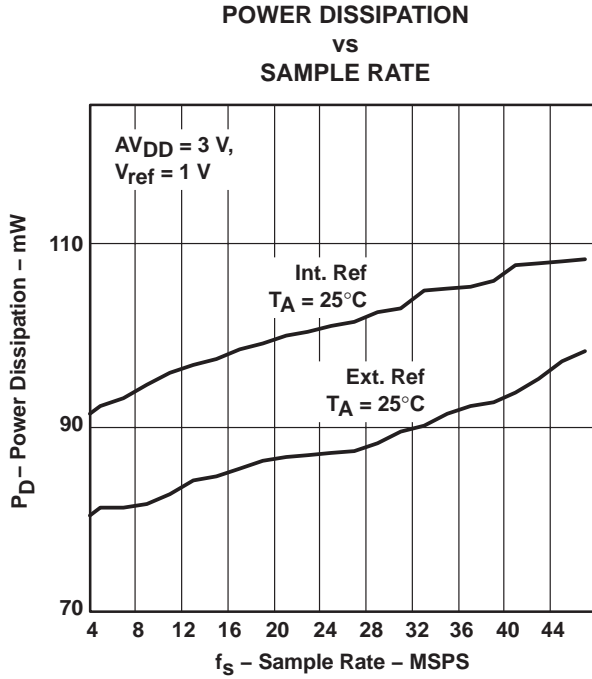

Figure 22

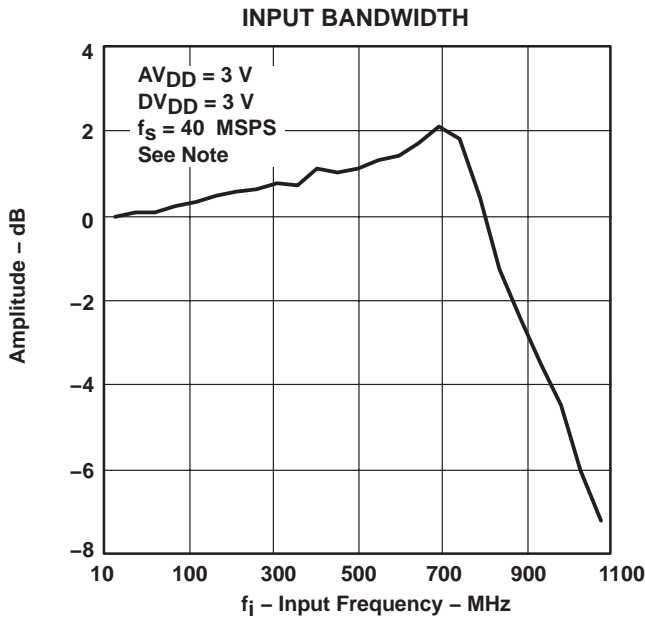

Figure 23

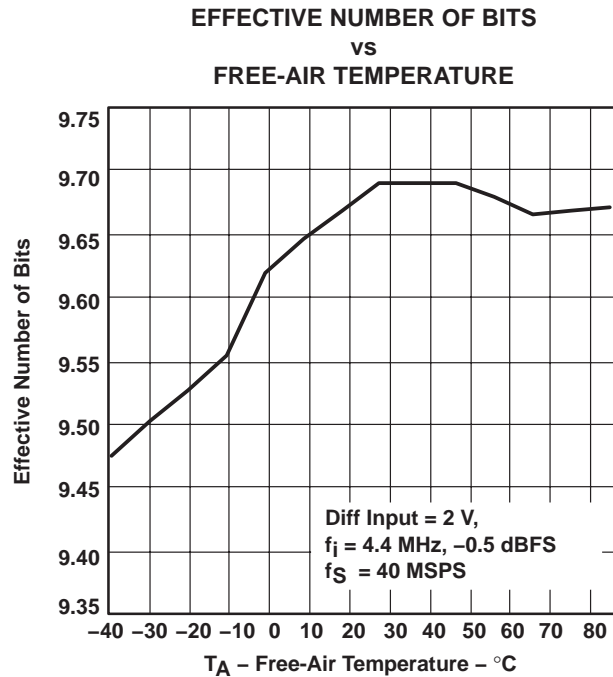

Figure 24

NOTE: No series resistors and no bypass capacitors at AIN+ and AIN- inputs

PRINCIPLES OF OPERATION

functional overview

Refer to functional block diagram. A single-ended, sample rate clock is required at pin CLK for device operation. Analog inputs AIN+ and AIN- are sampled on each rising edge of CLK in a switched capacitor sample and hold unit, the output of which feeds a programmable gain amplifier (PGA) to the ADC core, where analog-to-digital conversion is performed against the ADC reference voltages REFT and REFB.

Internal or external ADC reference voltage configurations are selected by connecting the MODE pin appropriately. When MODE = AGND, the user must provide external sources at pins REFB and REFT. When MODE = AV_{DD} or MODE = AV_{DD}/2, an internal ADC reference generator (A2) is enabled, which drives the REFT and REFB pins using the voltage at pin VREF as its input. The user can choose to drive VREF from the internal bandgap reference, or they can disable A1 and provide their own reference voltage at pin VREF.

On the fourth rising CLK edge following the edge that sampled AIN+ and AIN-, the conversion result is output via data pins I/O0 to I/O9. The output buffers can be disabled by pulling pin OE high, allowing the user to place device configuration data on the data pins, which are then latched into the internal control registers by strobing the WR pin high then low. The internal registers control the data output format (unsigned or twos complement), the PGA gain, device powerdown, the clamp functions, and the clamp DAC voltage.

The THS1041 offers a clamp circuit suitable for dc restoration of ac-coupled signals. The clamp voltage level can be set using an external reference applied to the CLAMPIN pin, or it can be set to a reference level provided by an on-chip 10-bit DAC. The CLAMPOUT pin must be connected externally to AIN+ or AIN- in applications requiring the clamp function.

The following sections explain further:

- How signals flow from AIN+ and AIN- to the ADC core, and how the reference voltages at REFT and REFB set the ADC input range and hence the input range at AIN+ and AIN-
- How to set the ADC references REFT and REFB using external sources or the internal ADC reference buffer (A2) to match the device input range to the input signal
- How to set the output of the internal bandgap reference (A1) if required
- How to use the clamp and device control registers

signal processing chain (sample and hold, PGA, ADC)

Figure 25 shows the signal flow through the sample and hold unit and the PGA to the ADC core.

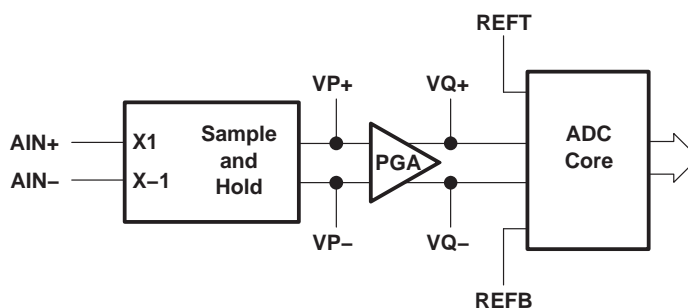

Figure 25. Analog Input Signal Flow

PRINCIPLES OF OPERATION

sample-and-hold

Differential input signal sources can be connected directly to the AIN+ and AIN– pins using either dc- or ac-coupling.

For single-ended sources, the signal can be dc- or ac-coupled to one of AIN+ or AIN–, and a suitable reference voltage (usually the midscale voltage, see *operating configuration examples*) must be applied to the other pin. Note that connecting the signal to AIN– results in it being inverted during sampling.

The sample and hold differential output voltage $V_P = V_{P+} - V_{P-}$ is given by

$$V_P = (A_{IN+}) - (A_{IN-}) \quad (1)$$

A clamp is available for dc restoration of ac-coupled single-ended inputs (see *clamp operation*).

programmable gain amplifier

V_P is amplified by the PGA and fed to the ADC as a voltage $V_Q = V_{Q+} - V_{Q-}$ where

$$V_Q = \text{Gain} \times V_P = \text{Gain} \times [(A_{IN+}) - (A_{IN-})] \quad (2)$$

analog-to-digital converter

V_Q is digitized by the ADC, using the voltages at pins REFT and REFB to set the ADC zero-scale (code 0) and full-scale (code 1023) input voltages.

$$V_Q(\text{ZS}) = -(\text{REFT} - \text{REFB}) \quad (3)$$

$$V_Q(\text{FS}) = (\text{REFT} - \text{REFB}) \quad (4)$$

Any inputs at AIN+ and AIN– that give V_Q voltages less than $V_Q(\text{ZS})$ or greater than $V_Q(\text{FS})$ lie outside the ADC's conversion range and attempts to convert such voltages are signalled by driving pin OVR high when the conversion result is output. V_Q voltages less than $V_Q(\text{ZS})$ digitize to give ADC output code 0, and V_Q voltages greater than $V_Q(\text{FS})$ give ADC output code 1023.

complete system and system input range

Combining the above equations to find the input voltages $[(A_{IN+}) - (A_{IN-})]$ that correspond to the limits of the ADC's valid input range gives:

$$\frac{(\text{REFB} - \text{REFT})}{\text{Gain}} \leq [(A_{IN+}) - (A_{IN-})] \leq \frac{(\text{REFT} - \text{REFB})}{\text{Gain}} \quad (5)$$

For both single-ended and differential inputs, the ADC can thus handle signals with a peak-to-peak input range $[(A_{IN+}) - (A_{IN-})]$ of:

$$[(A_{IN+}) - (A_{IN-})] \text{ pk-pk input range} = 2 \times \frac{(\text{REFT} - \text{REFB})}{\text{Gain}} \quad (6)$$

The next sections describe the options available to the user for setting the REFT and REFB voltages to obtain the desired input range and performance in their THS1041 applications.

PRINCIPLES OF OPERATION

ADC reference generation

The THS1041 ADC references REFT and REFB can be driven from external (off-chip) sources or from the internal A2 reference buffer. The voltage at the MODE pin determines the ADC references source.

Connecting MODE to AGND enables external ADC references mode. In this mode the internal buffer A2 is powered down and the user must provide the REFT and REFB voltages by connecting external sources directly to these pins. This mode is useful where several THS1041 devices must share common references for best matching of their ADC input ranges, or when the application requires better accuracy and temperature stability than the on-chip reference source can provide.

Connecting MODE to AV_{DD} or AV_{DD}/2 enables internal ADC references mode. In this mode the buffer A2 is powered up and drives the REFT and REFB pins. External reference sources should not be connected in this mode. Using internal ADC references mode when possible helps to reduce the component count and hence the system cost.

When MODE is connected to AV_{DD}, a buffered AV_{DD}/2 voltage is also available at the CLAMPOUT pin. This voltage can be used as a dc bias level for any ac-coupling networks connecting the input signal sources to the AIN+ and AIN– pins.

MODE PIN	REFERENCE SELECTION	CLAMPOUT PIN FUNCTION
AGND	External	Clamp
AV _{DD} /2	Internal	Clamp
AV _{DD}	Internal	AV _{DD} /2 for AIN± bias

external reference mode (MODE = AGND)

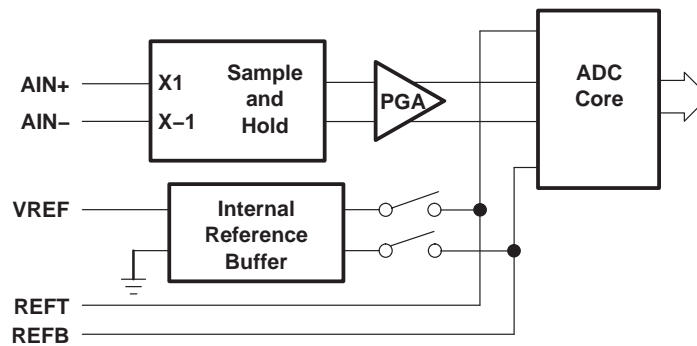

Figure 26. ADC Reference Generation, MODE = AGND

Connecting pin MODE to AGND powers-down the internal references buffer A2 and disconnects its outputs from the REFT and REFB pins. The user must connect REFT and REFB to external sources to provide the ADC reference voltages required to match the THS1041 input range to their application requirements. The common-mode reference voltage must be AV_{DD}/2 for correct THS1041 operation:

$$\frac{(\text{REFT} + \text{REFB})}{2} = \frac{AV_{DD}}{2} \quad (7)$$

PRINCIPLES OF OPERATION

internal reference mode (MODE = AV_{DD} or AV_{DD}/2)

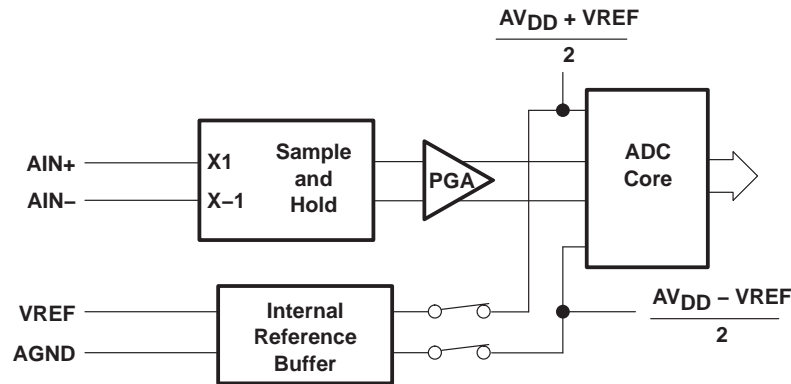

Figure 27. ADC Reference Generation, MODE = AV_{DD}/2

Connecting MODE to AV_{DD} or AV_{DD}/2 enables the internal ADC references buffer A2. The outputs of A2 are connected to the REFT and REFB pins and its inputs are connected to pins VREF and AGND. The resulting voltages at REFT and REFB are:

$$REFT = \frac{(AV_{DD} + VREF)}{2} \tag{8}$$

$$REFB = \frac{(AV_{DD} - VREF)}{2} \tag{9}$$

Depending on the connection of the REFSENSE pin, the voltage on VREF may be driven by an off-chip source or by the internal bandgap reference (A1) (see *onboard reference generator configuration*) to match the THS1041 input range to their application requirements.

When MODE = AV_{DD} the CLAMPOUT pin provides a buffered, stabilized AV_{DD}/2 output voltage that can be used as a bias reference for ac coupling networks connecting the signal sources to the AIN+ or AIN- inputs. This removes the need for the user to provide a stabilized external bias reference.

PRINCIPLES OF OPERATION

internal reference mode (MODE = AV_{DD} or AV_{DD}/2) (continued)

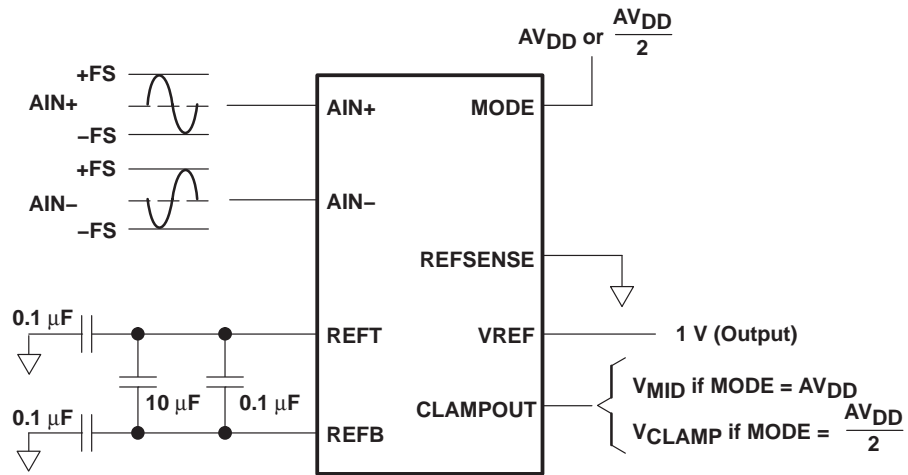

Figure 28. Internal Reference Mode, 1-V Reference Span

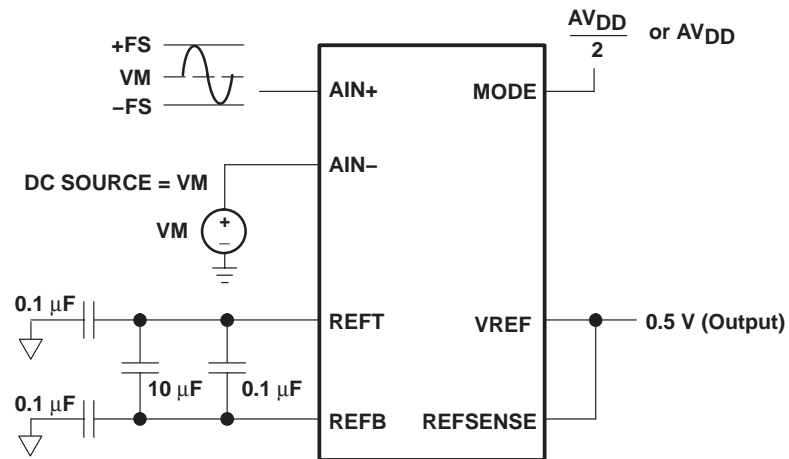

Figure 29. Internal Reference Mode, 0.5-V Reference Span, Single-Ended Input

PRINCIPLES OF OPERATION

onboard reference generator configuration

The internal bandgap reference A1 can provide a supply-voltage-independent and temperature-independent voltage on pin VREF.

External connections to REFSENSE control A1's output to the VREF pin as shown in Table 1.

Table 1. Effect of REFSENSE Connection on VREF Value

REFSENSE CONNECTION	A1 OUTPUT TO VREF	REFER TO:
VREF pin	0.5 V	Figure 30
AGND	1 V	Figure 31
External divider junction	$(1 + R_a/R_b)/2$ V	Figure 32
AV _{DD}	Open circuit	Figure 33

REFSENSE = AV_{DD} powers the internal bandgap reference A1 down, saving power when A1 is not required. If MODE is connected to AV_{DD} or AV_{DD}/2, then the voltage at VREF determines the ADC reference voltages:

$$REFT = \frac{AV_{DD}}{2} + \frac{VREF}{2} \tag{10}$$

$$REFB = \frac{AV_{DD}}{2} - \frac{VREF}{2} \tag{11}$$

$$REFT - REFB = VREF \tag{12}$$

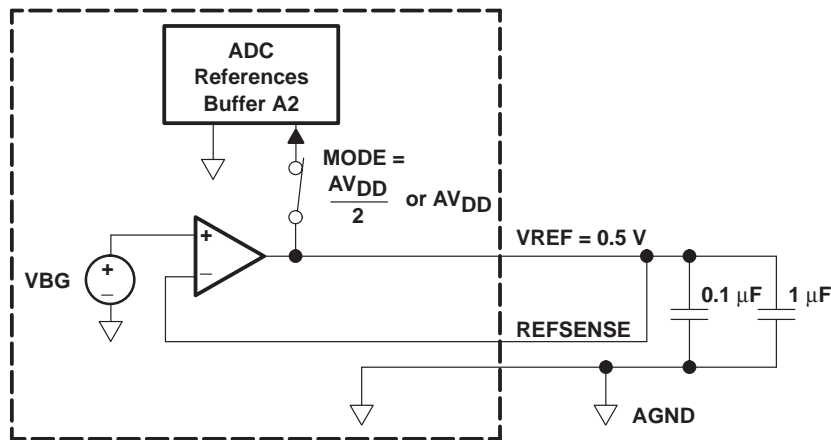

Figure 30. 0.5-V VREF Using the Internal Bandgap Reference A1

PRINCIPLES OF OPERATION

onboard reference generator configuration (continued)

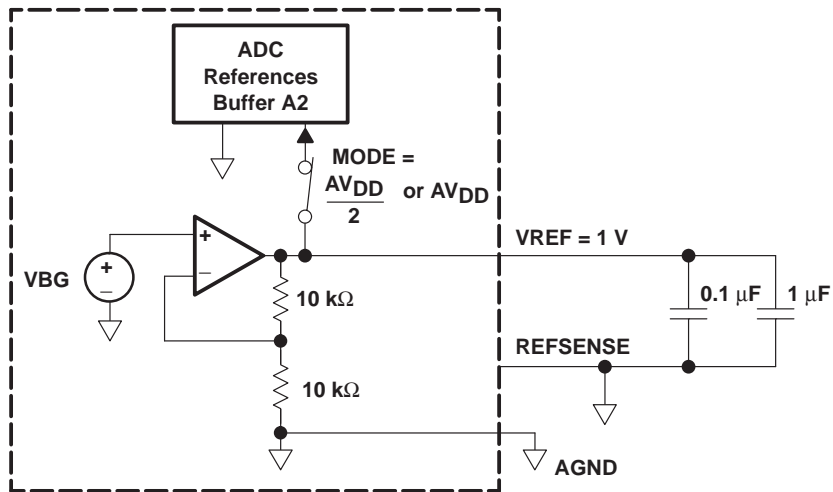

Figure 31. 1-V VREF Using the Internal Bandgap Reference A1

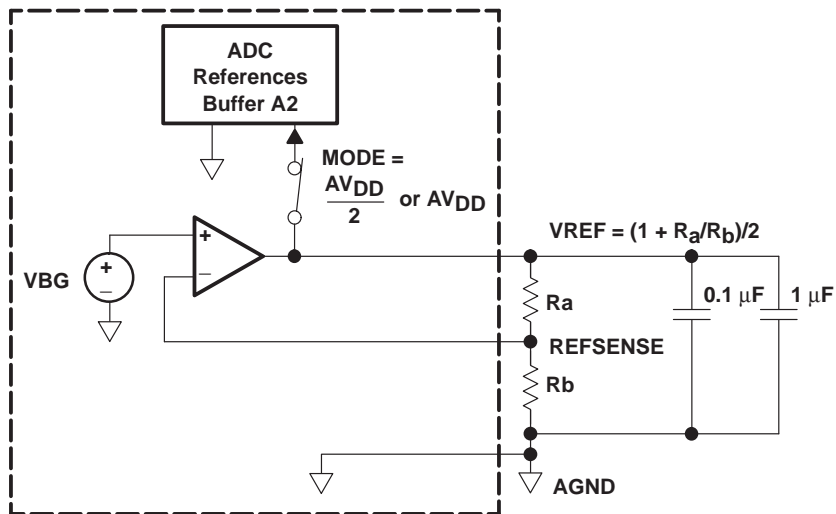

Figure 32. External Divider Mode

PRINCIPLES OF OPERATION

onboard reference generator configuration (continued)

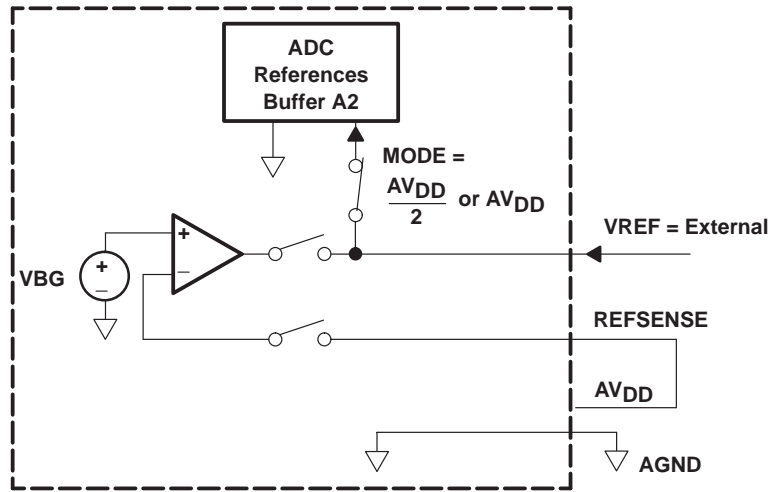

Figure 33. Drive VREF Mode

operating configuration examples

Figure 34 shows a configuration using the internal ADC references for digitizing a single-ended signal with span 0 V to 2 V. Tying REFSENSE to ground gives 1 V at pin VREF. Tying MODE to $AV_{DD}/2$ then sets the REFT and REFB voltages via the internal reference generator for a 2- V_{p-p} ADC input range and the CLAMPOUT pin also provides the midscale 1-V bias for the AIN- input. Using the clamp to drive AIN- rather than connecting AIN- directly to VREF helps to prevent kickback from the AIN- pin corrupting VREF. AIN- can be connected to VREF, provided that VREF is well-decoupled to analog ground. Internal PGA gain setting is 1.

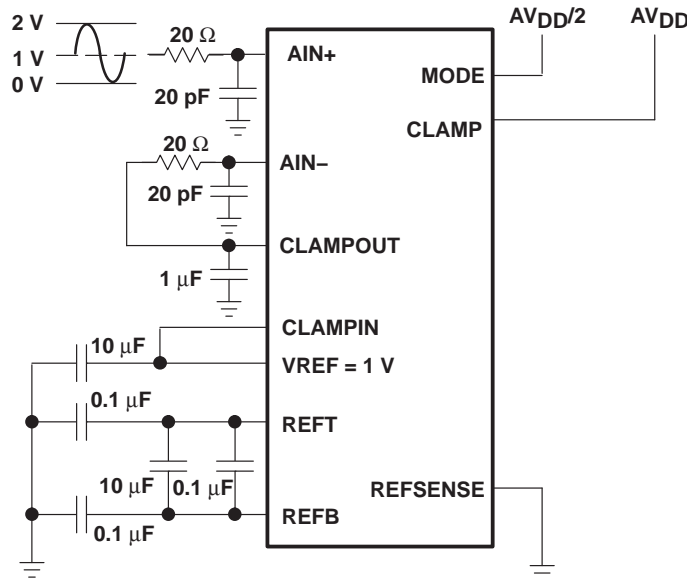

Figure 34. Operating Configuration: 2-V Single-Ended Input, Internal ADC References

PRINCIPLES OF OPERATION

operating configuration examples (continued)

Figure 35 shows a configuration using the internal ADC references for digitizing a dc-coupled differential input with 1.5-V_{p-p} span and 1.5-V common-mode voltage. External resistors are used to set the internal bandgap reference output at VREF to 0.75 V. Tying MODE to AV_{DD} then sets the REFT and REFB voltages via the internal reference generator for a 1.5-V_{p-p} ADC input range.

If a transformer is used to generate the differential ADC input from a single-ended signal, then the CLAMPOUT pin provides a suitable bias voltage for the secondary windings center tap when MODE = AV_{DD}.

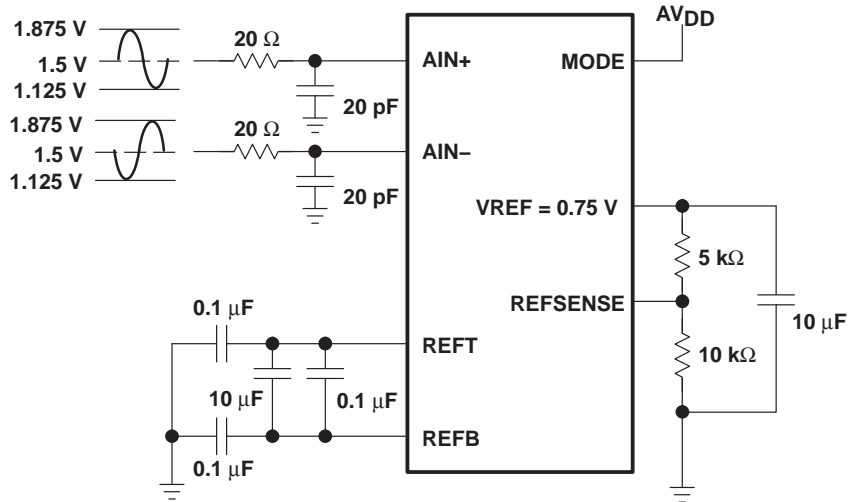

Figure 35. Operating Configuration: 1.5-V Differential Input, Internal ADC References

Figure 36 shows a configuration using the internal ADC references and an external VREF source for digitizing a dc coupled single-ended input with span 0.5 V to 2 V. A 1.25-V external source provides the bias voltage for the AIN- pin and also, via a buffered potential divider; the 0.75 VREF voltage required to set the input range to 1.5 V_{p-p}. MODE is tied to AV_{DD} to set internal ADC references configuration.

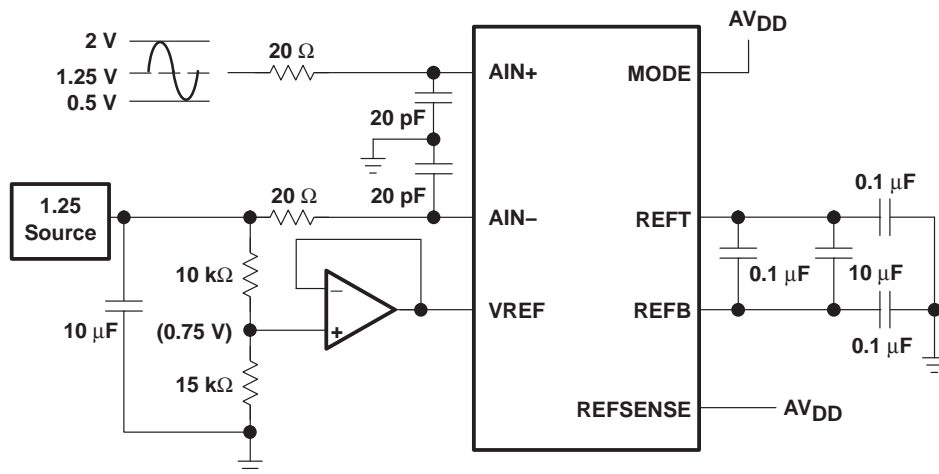

Figure 36. Operating Configuration: 1.5-V Single-Ended Input, External VREF Source

PRINCIPLES OF OPERATION

operating configuration examples (continued)

Figure 37 shows a configuration using external ADC references for digitizing a differential input with span 0.8 V. To maximize the signal swing at the ADC core, the PGA gain is set to 2.5 to give a $2-V_{p-p}$ output from the PGA. MODE is tied to ground to disable the internal reference buffer. The external ADC reference sources must set REFT 1 V higher than REFB to set the ADC input span to $2 V_{p-p}$, and the voltages provided by the external sources must be centered near $AV_{DD}/2$ for best ADC operation. REFSENSE is shown tied to AV_{DD} to disable the internal bandgap reference (A1), though other components in the system may use the VREF output if desired.

External ADC references are best suited to applications which require the tighter reference voltage tolerance and temperature coefficient than the internal bandgap reference (A1) can provide, or where the references are to be shared among several THS1041 ADCs for best matching of their ADC channels.

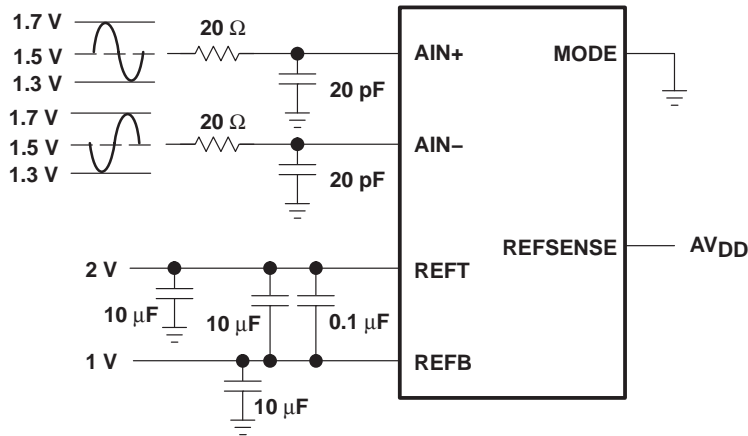

Figure 37. Operating Configuration: 0.8-V Differential Input and External ADC References

clamp operation

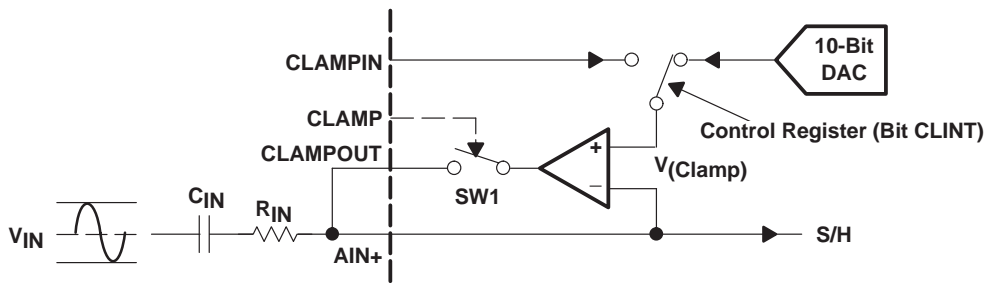

Figure 38. Schematic of Clamp Circuitry

The THS1041 provides a clamp function for restoring a dc reference level to the signal at AIN+ or AIN- which has been lost through ac-coupling from the signal source to this pin.

Figure 38 and Figure 39 show an example of using the clamp to restore the black level of a composite video input ac-coupled to AIN+. While the clamp pin is held high, the clamp amplifier forces the voltage at AIN+ to equal the clamp reference voltage, setting the dc voltage at AIN+ for the video black level.

After power up, the clamp reference voltage is the voltage on the CLAMPIN pin. This reference can instead be taken from the internal CLAMP DAC by suitably programming the THS1041 clamp and control registers.

Clamp acquisition and clamp droop design calculations are discussed later.

PRINCIPLES OF OPERATION

clamp operation (continued)

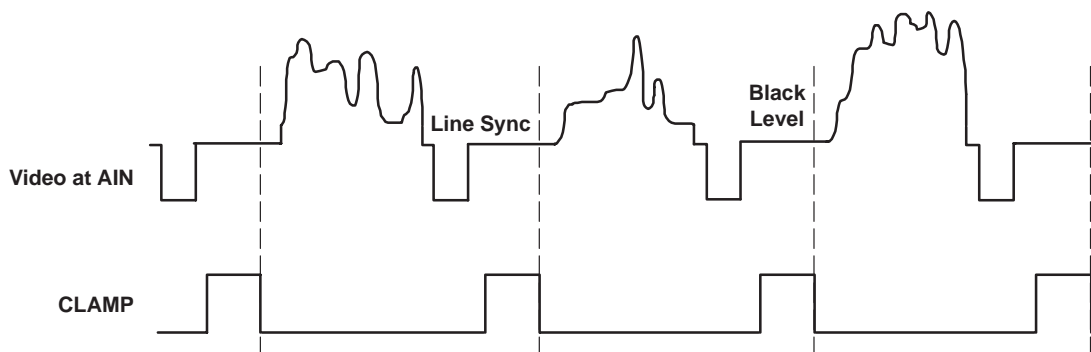

Figure 39. Example Waveforms for Line-Clamping to a Video Input Black Level

clamp DAC output voltage range and limits

When using the internal clamp DAC, the user must ensure that the desired dc clamp level at AIN+/- lies within the voltage range V_{REFB} to V_{REFT} . This is because the clamp DAC voltage is constrained to lie within this range V_{REFB} to V_{REFT} . Specifically:

$$VDAC = V_{REFB} + (V_{REFT} - V_{REFB}) \times (0.006 + 0.988 \times (\text{DAC code})/1024) \tag{13}$$

DAC codes can range from 0 to 1023. Figure 40 graphically shows the clamp DAC output voltage versus the DAC code.

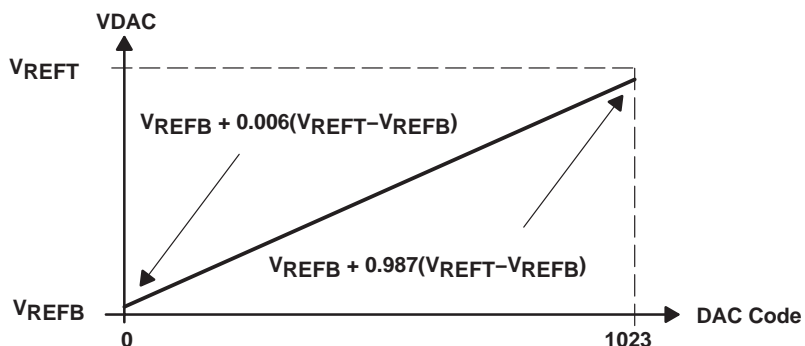

Figure 40. Clamp DAC Output Voltage Versus DAC Register Code Value

If the desired dc level at AIN+/- does not lie within the voltage range V_{REFT} to V_{REFB} , then either the CLAMPIN pin can be used instead to provide a suitable reference voltage, or it may be possible to redesign the application to move the AIN+/- input range into the CLAMP DAC voltage range.

PRINCIPLES OF OPERATION

power management

In power-sensitive applications (such as battery-powered systems) where the THS1041 ADC is not required to convert continuously, power can be saved between conversion intervals by placing the THS1041 into power-down mode. This is achieved by setting bit 3 (PWDN) of the control register to 1. In power-down mode, the device typically consumes less than 0.1 mW. Power-down mode is exited by resetting control register bit 3 to 0. On power up, typical wake-up and power-up times apply. See *power supply* section.

In systems where the ADC must run continuously, but where the clamp is not required, the supply current can be reduced by approximately 1.2 mA by setting the control register bit 6 (CLDIS) to 1, which disables the clamp circuit. Similarly, when REFSENSE is tied to AV_{DD}, the reference generator is disabled and supply current reduced by approximately 1.2 mA.

output format and digital I/O

While the \overline{OE} pin is held low, ADC conversion results are output at pins I/O0 (LSB) to I/O9 (MSB). The ADC input over-range indicator is output at pin OVR. OVR is also disabled when \overline{OE} is held high.

The default ADC output data format is unsigned binary (output codes 0 to 1023). The output format can be switched to 2s complement (output codes -512 to 511) by setting control register bit 5 (TWOC) to 1.

writing to the internal registers through the digital I/O bus

Pulling pin \overline{OE} high disables the I/O and OVR pin output drivers, placing the driver outputs in a high impedance state. This allows control register data to be loaded into the THS1041 by presenting it on the I/O0 to I/O9 pins and pulsing the WR pin high then low to latch the data into the chosen control or DAC register.

Figure 41 shows an example register write cycle where the clamp DAC code is set to 10F (hex) by writing to clamp registers 1 and 2 (see the register map in Table 2). Pins I/O0 to I/O7 are driven to the clamp DAC code lower byte (0F hex), and pins I/O8 and I/O9 are both driven to 0 to select clamp register 1 as the data destination. The clamp low-byte data is then loaded into this register by pulsing WR high. The top 2 bits of the DAC word are then loaded by driving 01(hex) on pins I/O0 to I/O7 and by driving pin I/O8 to 1 and pin I/O9 to 0 to select clamp register 2 as the data destination. WR is pulsed a second time to latch this second control word into clamp register 2. Interface timing parameters are given in Figures 1 and 2.

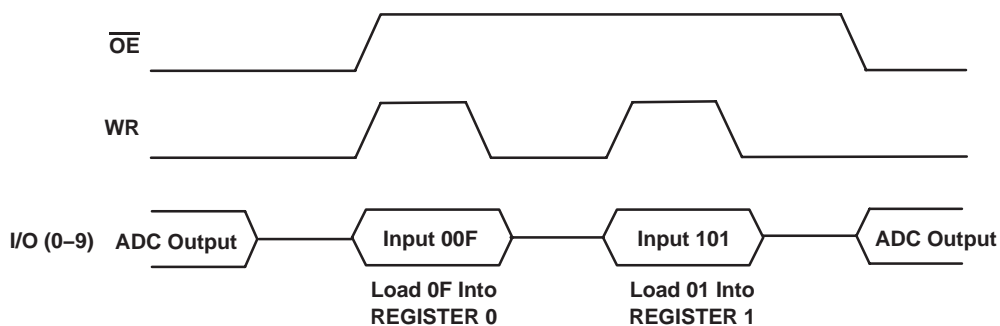

Figure 41. Example Register Write Cycle to Clamp DAC Register

PRINCIPLES OF OPERATION

digital control registers

The THS1041 contains two clamp registers and a control register for user programming of THS1041 operation. Binary data can be written into these registers by using pins I/O0 to I/O9 and the WR and OE pins (see the previous section). In input mode, the two I/O bus MSBs are address bits, 00 addressing clamp register 1, 01 clamp register 2, and 10 the control register. The clamp registers and control registers are *write only* registers, and stored values cannot be read on the I/O data bus.

Table 2. Register Map

ADDRESS I/O[9:8]	DESCRIPTION	DEF (HEX)	W	BIT							
				B7	B6	B5	B4	B3	B2	B1	B0
00	Clamp register 1	00	W	DAC[7]	DAC[6]	DAC[5]	DAC[4]	DAC[3]	DAC[2]	DAC[1]	DAC[0]
01	Clamp register 2	00	W							DAC[9]	DAC[8]
10	Control register	01	W		CLDIS	TWOC	CLINT	PDWN	PGA[2]	PGA[1]	PGA[0]
11†	Reserved†										

† Do not write to register 11

Table 3. Register Contents

REGISTER	BIT NO	BIT NAME(S)	DEFAULT	DESCRIPTION
Control register I/O[9:8] = 10	2:0	PGA[2:0]	001	PGA gain: 000 = 0.5 001 = 1.0 (default value) 010 = 1.5 011 = 2.0 100 = 2.5 101 = 3.0 110 = 3.5 111 = 4.0
	3	PDWN	0	Power down 0 = THS1041 powered up 1 = THS1041 powered down
	4	CLINT	0	Clamp voltage internal/external 0 = external analog clamp voltage from CLAMPIN pin 1 = from onboard DAC (see clamp register)
	5	TWOC	0	Output format 0 = unsigned binary 1 = twos complement
	6	CLDIS	0	CLAMPOUT pin disable (for power saving) 0 = Enable 1 = Disable
	7			Unused
Clamp register 1 I/O[9:8] = 00	7:0	DAC[7:0]	0	Clamp DAC voltage (DAC[0] = LSB.) DAC[9:0] = 00h: Clamp voltage = REFB DAC[9:0] = 3Fh: Clamp voltage = REFT
Clamp register 2 I/O[9:8] = 01	7:2			Unused
	1:0	DAC[9:8]	0	Clamp DAC voltage (DAC[9] = MSB)

APPLICATION INFORMATION

driving the THS1041 analog inputs

driving the clock input

Obtaining good performance from the THS1041 requires care when driving the clock input.

Different sections of the sample-and-hold and ADC operate while the clock is low or high. The user should ensure that the clock duty cycle remains near 50% to ensure that all internal circuits have as much time as possible in which to operate.

The CLK pin should also be driven from a low jitter source for best dynamic performance. To maintain low jitter at the CLK input, any clock buffers external to the THS1041 should have fast rising edges. Use a fast logic family such as AC or ACT to drive the CLK pin, and consider powering any clock buffers separately from any other logic on the PCB to prevent digital supply noise appearing on the buffered clock edges as jitter.

As the CLK input threshold is nominally around $AV_{DD}/2$, any clock buffers need to have an appropriate supply voltage to drive above and below this level.

driving the sample and hold inputs

driving the AIN+ and AIN- pins

Figure 42 shows an equivalent circuit for the THS1041 AIN+ and AIN- pins. The load presented to the system at the AIN pins comprises the switched input sampling capacitor, C_{Sample} , and various stray capacitances, C_1 and C_2 .

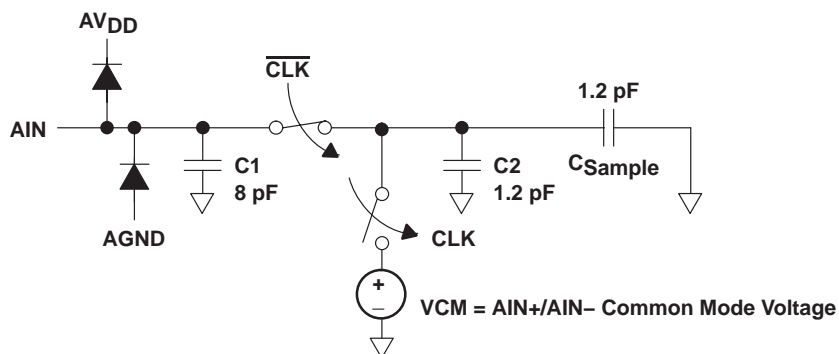

Figure 42. Equivalent Circuit for Analog Input Pins AIN+ and AIN-

The input current pulses required to charge C_{Sample} and C_2 can be time averaged and the switched capacitor circuit modelled as an equivalent resistor:

$$R_{IN2} = \frac{1}{C_S \times f_{CLK}} \tag{14}$$

where C_S is the sum of C_{Sample} and C_2 . This model can be used to approximate the input loading versus source resistance for high impedance sources.

APPLICATION INFORMATION

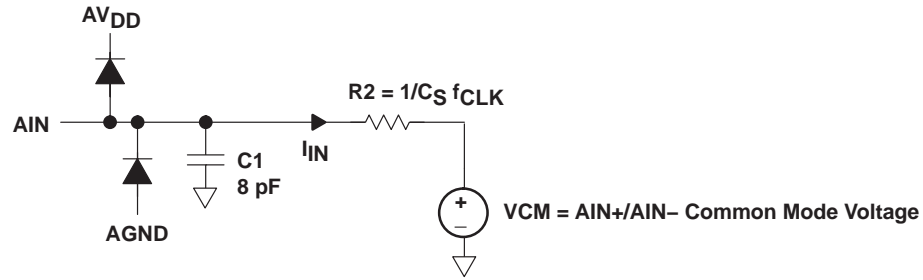

Figure 43. Equivalent Circuit for the AIN Switched Capacitor Input

AIN input damping

The charging current pulses into AIN+ and AIN– can make the signal sources jump or ring, especially if the sources are slightly inductive at high frequencies. Inserting a small series resistor of 20 Ω or less and a small capacitor to ground of 20 pF or less in the input path can damp source ringing (see Figure 44). The resistor and capacitor values can be made larger than 20 Ω and 20 pF if reduced input bandwidth and a slight gain error (due to potential division between the external resistors and the AIN equivalent resistors) are acceptable.

Note that the capacitors should be soldered to a clean analog ground with a common ground point to prevent any voltage drops in the ground plane appearing as a differential voltage at the ADC inputs.

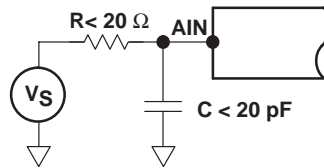

Figure 44. Damping Source Ringing Using a Small Resistor and Capacitor

driving the VREF pin

Figure 45 shows the equivalent load on the VREF pin when driving the ADC internal references buffer via this pin (MODE = AV_{DD}/2 or AV_{DD} and REFSENSE = AV_{DD}).

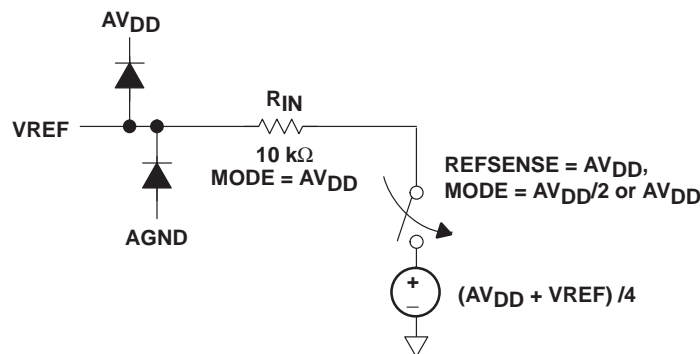

Figure 45. Equivalent Circuit of VREF

The nominal input current I_{REF} is given by:

$$I_{REF} = \frac{3 V_{REF} - AV_{DD}}{4 \times R_{IN}} \tag{15}$$

APPLICATION INFORMATION

driving the VREF pin (continued)

Note that the maximum current may be up to 30% higher. The user should ensure that VREF is driven from a low noise, low drift source, well decoupled to analog ground and capable of driving the maximum I_{REF}.

driving REFT and REFB (external ADC references, MODE = AGND)

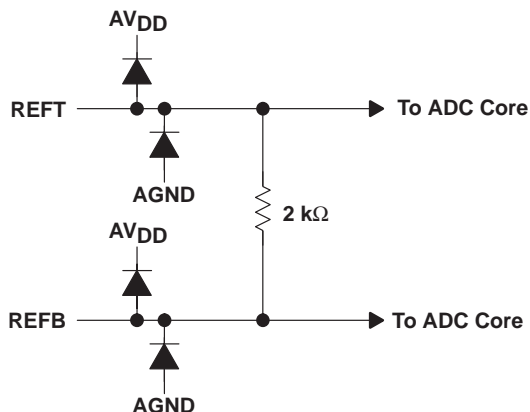

Figure 46. Equivalent Circuit of REFT and REFB Inputs

designing the dc clamp

Figure 38 shows the basic operation of the clamp circuit with the analog input AIN+ coupled via an RC circuit. AIN- must be connected to a dc source whose voltage level keeps the THS1041 differential input within the ADC input range. The clamp voltage output level may be established by an analog voltage on the CLAMPIN pin or by programming the on-chip clamp DAC.

(Note that it is possible to reverse the AIN+ and AIN- connections if signal inversion is also required. The following section assumes that the signal is coupled to AIN+ and that AIN- is connected to a suitable dc bias level).

initial clamp acquisition time

Acquisition time is the time required to reach the target clamp voltage at AIN+ when the clamp switch SW1 is closed for the first time. The acquisition time is given by

$$T_{ACQ} = C_{IN} \times R_{IN} \times \ln \left(\frac{V_C}{V_E} \right) \tag{16}$$

where V_C is the difference between the dc level of the input V_{IN} and the target clamp output voltage, V_{Clamp}. V_E is the difference between the ideal V_C and the actual V_C obtained during the acquisition time. The maximum tolerable error depends on the application requirements.

For example, consider clamping an incoming video signal that has a black level near 0.3 V to a black level of 1.3 V at the THS1041 AIN+ input. The voltage V_C required across the input coupling capacitor is thus 1.3 – 0.3 = 1 V. If a 10 mV or less clamp voltage error V_E gives acceptable system operation, the source resistance R_{IN} is 20 Ω and the coupling capacitor C_{IN} is 1 μF, then the total clamp pulse duration required to reach this error is:

$$T_{ACQ} = 1 \mu F \times 20 \Omega \times \ln(1/0.01) = 92 \mu s \text{ (approximate)}$$

APPLICATION INFORMATION

initial clamp acquisition time (continued)

Initial acquisition can be performed in two ways:

- Pulsing the CLAMP pin as in normal operation. Provided that clamp droop (see below) is negligible, initial acquisition is complete when the total clamped (CLAMP = high) time equals T_{ACQ} .
- Pulling the CLAMP pin high for the required acquisition time before starting normal operation. This method is faster, though possibly less convenient for the user to implement.

clamp droop

The charging currents drawn by the sample-and-hold switched capacitor input can charge or discharge C_{IN} , causing the dc voltage at AIN+ to drift towards the dc bias voltage at AIN– during the time between clamp pulses. This effect is called clamp droop.

Voltage droop is a function of the AIN+ and AIN– input currents to the THS1041, I_{IN} , and the time between clamp intervals, t_D :

$$V_{DROOP} \approx \left(\frac{I_{IN}}{C_{IN}} \right) \times t_D \text{ (approximate)} \quad (17)$$

Worst case droop between clamping intervals occurs for maximum input bias current. Maximum input current is I_{INFS} , which occurs when the input level is at its maximum or minimum.

For example, at 40 MSPS I_{INFS} is approximately 20 μA for a 2-V input range at AIN (assuming 2 V appear across RIN2—see *driving the sample and hold reference inputs* to calculate R_{IN2}). Note that I_{INFS} may vary from this by $\pm 30\%$ because of processing variations and voltage dependencies. Designs should allow for this variation. If the time t_D between clamping intervals is 63.5 μs and C_{IN} is 1 μF , then the maximum clamp level droop between clamp pulses is

$$\begin{aligned} V_{DROOP}(\text{max}) &= 20 \mu\text{A}/1 \mu\text{F} \times 63.5 \mu\text{s} = 1.25 \text{ mV (approximate, ignoring 30\% tolerance)} \\ &= 0.62 \text{ LSB at PGA gain} = 1, 2 \text{ V ADC references} \end{aligned} \quad (18)$$

If this droop is greater than can be tolerated in the application, then increase C_{IN} to slow the droop and hence reduce the voltage change between clamp pulses.

If a high leakage capacitor is used for coupling the input source to the AIN pin then the droop may be significantly worse than calculated above. Avoid using electrolytic and tantalum coupling capacitors as these have higher leakage currents than nonpolarized capacitor types. Electrolytic and tantalum capacitors also tend to have higher parasitic inductance, which can cause problems at high input frequencies.

steady-state clamp voltage error

During the clamp pulse (CLAMP = high), the dc voltage on AIN is refreshed from the clamp voltage. Provided that droop is not excessive, clamping fully reverses the effect of droop. However, using very short clamp pulses with long intervals between pulses (t_D) can result in a steady-state voltage difference, V_{COS} , between the dc voltage at AIN and $V_{(Clamp)}$.

Figure 47 shows the approximate voltage waveform at AIN resulting from a large clamp droop during t_D and clamp voltage reacquisition during the clamp pulse time, t_C .

APPLICATION INFORMATION

steady-state clamp voltage error (continued)

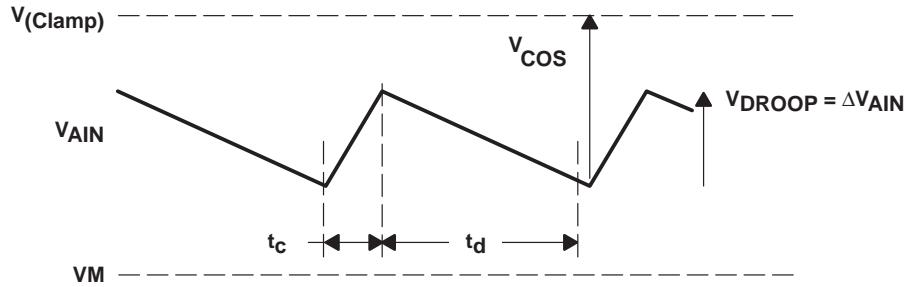

Figure 47. Approximate Waveforms at AIN During Droop and Clamping

The voltage change at AIN during acquisition has been approximated as a linear charging ramp by assuming that almost all of V_{COS} appears across R_{IN} , giving a charging current V_{COS}/R_{IN} (this is a reasonable approximation when V_{COS} is large enough to be of concern). The voltage change at AIN during clamp acquisition is then:

$$\Delta V_{AIN} = \frac{V_{COS} \times t_d}{R_{IN} \times C_{IN}} \tag{19}$$

The peak-to-peak voltage variation at AIN must equal the clamp droop voltage at steady state. Equating the droop voltage to the clamp acquisition voltage change gives:

$$V_{COS} = \frac{R_{IN} \times I_{IN} \times t_d}{t_c} \tag{20}$$

Thus for low offset voltage, keep R_{IN} low, design for low droop and ensure that the ratio t_d/t_c is not unreasonably large.

reference decoupling

VREF pin

When the on-chip reference generator is enabled, the VREF pin should be decoupled to the circuit board's analog ground plane close to the THS1041 AGND pin via a 1- μ F capacitor and a 0.1- μ F ceramic capacitor.

REFT and REFB pins

In any mode of operation, the REFT and REFB pins should be decoupled as shown in Figure 48. Use short board traces between the THS1041 and the capacitors to minimize parasitic inductance.

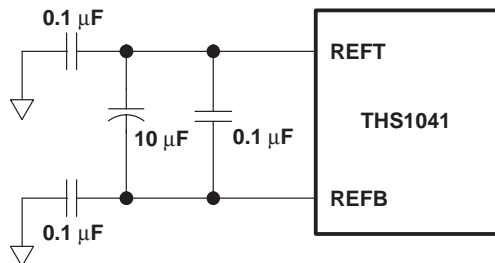

Figure 48. Recommended Decoupling for the ADC Reference Pins REFT and REFB

APPLICATION INFORMATION

CLAMPDOWN decoupling (when used as dc bias source)

When using CLAMPDOWN as a dc biasing reference (e.g., $MODE = AV_{DD}$), the CLAMPDOWN pin should be decoupled to the circuit board's analog ground plane close to the THS1041 AGND pin via a 1- μ F capacitor and a 0.1- μ F ceramic capacitor.

supply decoupling

The analog (AV_{DD} , AGND) and digital (DV_{DD} , DGND) power supplies to the THS1041 should be separately decoupled for best performance. Each supply needs at least a 10- μ F electrolytic or tantalum capacitor (as a charge reservoir) and a 100-nF ceramic type capacitor placed as close as possible to the respective pins (to suppress spikes and supply noise).

digital output loading and circuit board layout

The THS1041 outputs are capable of driving rail-to-rail with up to 10 pF of load per pin at 40-MHz clock frequency and 3-V digital supply. Minimizing the load on the outputs improves THS1041 signal-to-noise performance by reducing the switching noise coupling from the THS1041 output buffers to the internal analog circuits. The output load capacitance can be minimized by buffering the THS1041 digital outputs with a low input capacitance buffer placed as close to the output pins as physically possible, and by using the shortest possible tracks between the THS1041 and this buffer. Inserting small resistors in the range 100 Ω to 300 Ω between the THS1041 I/O outputs and their loads can help minimize the output-related noise in noise-critical applications.

Noise levels at the output buffers, which may affect the analog circuits within THS1041, increase with the digital supply voltage. Where possible, consider using the lowest DV_{DD} that the application can tolerate.

Use good layout practices when designing the application PCB to ensure that any off-chip return currents from the THS1041 digital outputs (and any other digital circuits on the PCB) do not return via the supplies to any sensitive analog circuits. The THS1041 should be soldered directly to the PCB for best performance. Socketing the device degrades performance by adding parasitic socket inductance and capacitance to all pins.

user tips for obtaining best performance from the THS1041

- Choose differential input mode for best distortion performance.
- Choose a 2-V ADC input span for best noise performance.
- Choose a 1-V ADC input span for best distortion performance.
- Drive the clock input CLK from a low-jitter, fast logic stage, with a well-decoupled power supply and short PCB traces.
- Use a small RC filter (typically 20 Ω and 20 pF) between the signal source(s) the AIN+ (and AIN-) input(s) when the systems bandwidth requirements allow this.

APPLICATION INFORMATION

definitions

- Integral nonlinearity (INL)—Integral nonlinearity refers to the deviation of each individual code from a line drawn from zero to full scale. The point used as zero occurs 1/2 LSB before the first code transition. The full-scale point is defined as a level 1/2 LSB beyond the last code transition. The deviation is measured from the center of each particular code to the true straight line between these two endpoints.
- Differential nonlinearity (DNL)—An ideal ADC exhibits code transitions that are exactly 1 LSB apart. DNL is the deviation from this ideal value. Therefore this measure indicates how uniform the transfer function step sizes are. The ideal step size is defined here as the step size for the device under test (i.e., (last transition level – first transition level) ÷ (2ⁿ – 2)). Using this definition for DNL separates the effects of gain and offset error. A minimum DNL better than –1 LSB ensures no missing codes.
- Zero-error—Zero-error is defined as the difference in analog input voltage—between the ideal voltage and the actual voltage—that switches the ADC output from code 0 to code 1. The ideal voltage level is determined by adding the voltage corresponding to 1/2 LSB to the bottom reference level. The voltage corresponding to 1 LSB is found from the difference of top and bottom references divided by the number of ADC output levels (1024).
- Full-scale error—Full-scale error is defined as the difference in analog input voltage—between the ideal voltage and the actual voltage—that will switch the ADC output from code 1022 to code 1023. The ideal voltage level is determined by subtracting the voltage corresponding to 1.5 LSB from the top reference level. The voltage corresponding to 1 LSB is found from the difference of top and bottom references divided by the number of ADC output levels (1024).
- Wake-up time—Wake-up time is from the power-down state to accurate ADC samples being taken and is specified for MODE = AGND with external reference sources applied to the device at the time of release of power-down, and an applied 40-MHz clock. Circuits that need to power up are the bandgap, bias generator, SHPGA, and ADC.
- Power-up time—Power-up time is from the power-down state to accurate ADC samples being taken and is specified for MODE = AV_{DD}/2 or AV_{DD} and an applied 40-MHz clock. Circuits that need to power up include VREF reference generation (A1), bias generator, ADC, the SHPGA, and the on-chip ADC reference generator (A2).
- Aperture delay—The delay between the 50% point of the rising edge of the clock and the instant at which the analog input is sampled.
- Aperture uncertainty (Jitter)—The sample-to-sample variation in aperture delay.

PACKAGING INFORMATION

Orderable Device	Status ⁽¹⁾	Package Type	Package Drawing	Pins	Package Qty	Eco Plan ⁽²⁾	Lead/Ball Finish	MSL Peak Temp ⁽³⁾
THS1041CDW	ACTIVE	SOIC	DW	28	20	Green (RoHS & no Sb/Br)	CU NIPDAU	Level-1-260C-UNLIM
THS1041CDWG4	ACTIVE	SOIC	DW	28	20	Green (RoHS & no Sb/Br)	CU NIPDAU	Level-1-260C-UNLIM
THS1041CPW	ACTIVE	TSSOP	PW	28	50	Green (RoHS & no Sb/Br)	CU NIPDAU	Level-1-260C-UNLIM
THS1041CPWG4	ACTIVE	TSSOP	PW	28	50	Green (RoHS & no Sb/Br)	CU NIPDAU	Level-1-260C-UNLIM
THS1041CPWR	ACTIVE	TSSOP	PW	28	2000	Green (RoHS & no Sb/Br)	CU NIPDAU	Level-1-260C-UNLIM
THS1041CPWRG4	ACTIVE	TSSOP	PW	28	2000	Green (RoHS & no Sb/Br)	CU NIPDAU	Level-1-260C-UNLIM
THS1041IDW	ACTIVE	SOIC	DW	28	20	Green (RoHS & no Sb/Br)	CU NIPDAU	Level-1-260C-UNLIM
THS1041IDWG4	ACTIVE	SOIC	DW	28	20	Green (RoHS & no Sb/Br)	CU NIPDAU	Level-1-260C-UNLIM
THS1041IPW	ACTIVE	TSSOP	PW	28	50	Green (RoHS & no Sb/Br)	CU NIPDAU	Level-1-260C-UNLIM
THS1041IPWG4	ACTIVE	TSSOP	PW	28	50	Green (RoHS & no Sb/Br)	CU NIPDAU	Level-1-260C-UNLIM

⁽¹⁾ The marketing status values are defined as follows:

ACTIVE: Product device recommended for new designs.

LIFEBUY: TI has announced that the device will be discontinued, and a lifetime-buy period is in effect.

NRND: Not recommended for new designs. Device is in production to support existing customers, but TI does not recommend using this part in a new design.

PREVIEW: Device has been announced but is not in production. Samples may or may not be available.

OBsolete: TI has discontinued the production of the device.

⁽²⁾ Eco Plan - The planned eco-friendly classification: Pb-Free (RoHS), Pb-Free (RoHS Exempt), or Green (RoHS & no Sb/Br) - please check <http://www.ti.com/productcontent> for the latest availability information and additional product content details.

TBD: The Pb-Free/Green conversion plan has not been defined.

Pb-Free (RoHS): TI's terms "Lead-Free" or "Pb-Free" mean semiconductor products that are compatible with the current RoHS requirements for all 6 substances, including the requirement that lead not exceed 0.1% by weight in homogeneous materials. Where designed to be soldered at high temperatures, TI Pb-Free products are suitable for use in specified lead-free processes.

Pb-Free (RoHS Exempt): This component has a RoHS exemption for either 1) lead-based flip-chip solder bumps used between the die and package, or 2) lead-based die adhesive used between the die and leadframe. The component is otherwise considered Pb-Free (RoHS compatible) as defined above.

Green (RoHS & no Sb/Br): TI defines "Green" to mean Pb-Free (RoHS compatible), and free of Bromine (Br) and Antimony (Sb) based flame retardants (Br or Sb do not exceed 0.1% by weight in homogeneous material)

⁽³⁾ MSL, Peak Temp. -- The Moisture Sensitivity Level rating according to the JEDEC industry standard classifications, and peak solder temperature.

Important Information and Disclaimer: The information provided on this page represents TI's knowledge and belief as of the date that it is provided. TI bases its knowledge and belief on information provided by third parties, and makes no representation or warranty as to the accuracy of such information. Efforts are underway to better integrate information from third parties. TI has taken and continues to take reasonable steps to provide representative and accurate information but may not have conducted destructive testing or chemical analysis on incoming materials and chemicals. TI and TI suppliers consider certain information to be proprietary, and thus CAS numbers and other limited information may not be available for release.

In no event shall TI's liability arising out of such information exceed the total purchase price of the TI part(s) at issue in this document sold by TI to Customer on an annual basis.

TAPE AND REEL INFORMATION
REEL DIMENSIONS

TAPE DIMENSIONS

A0	Dimension designed to accommodate the component width
B0	Dimension designed to accommodate the component length
K0	Dimension designed to accommodate the component thickness
W	Overall width of the carrier tape
P1	Pitch between successive cavity centers

TAPE AND REEL INFORMATION

*All dimensions are nominal

Device	Package Type	Package Drawing	Pins	SPQ	Reel Diameter (mm)	Reel Width W1 (mm)	A0 (mm)	B0 (mm)	K0 (mm)	P1 (mm)	W (mm)	Pin1 Quadrant
THS1041CPWR	TSSOP	PW	28	2000	330.0	16.4	6.9	10.2	1.8	12.0	16.0	Q1

TAPE AND REEL BOX DIMENSIONS

*All dimensions are nominal

Device	Package Type	Package Drawing	Pins	SPQ	Length (mm)	Width (mm)	Height (mm)
THS1041CPWR	TSSOP	PW	28	2000	367.0	367.0	38.0

DW (R-PDSO-G28)

PLASTIC SMALL OUTLINE

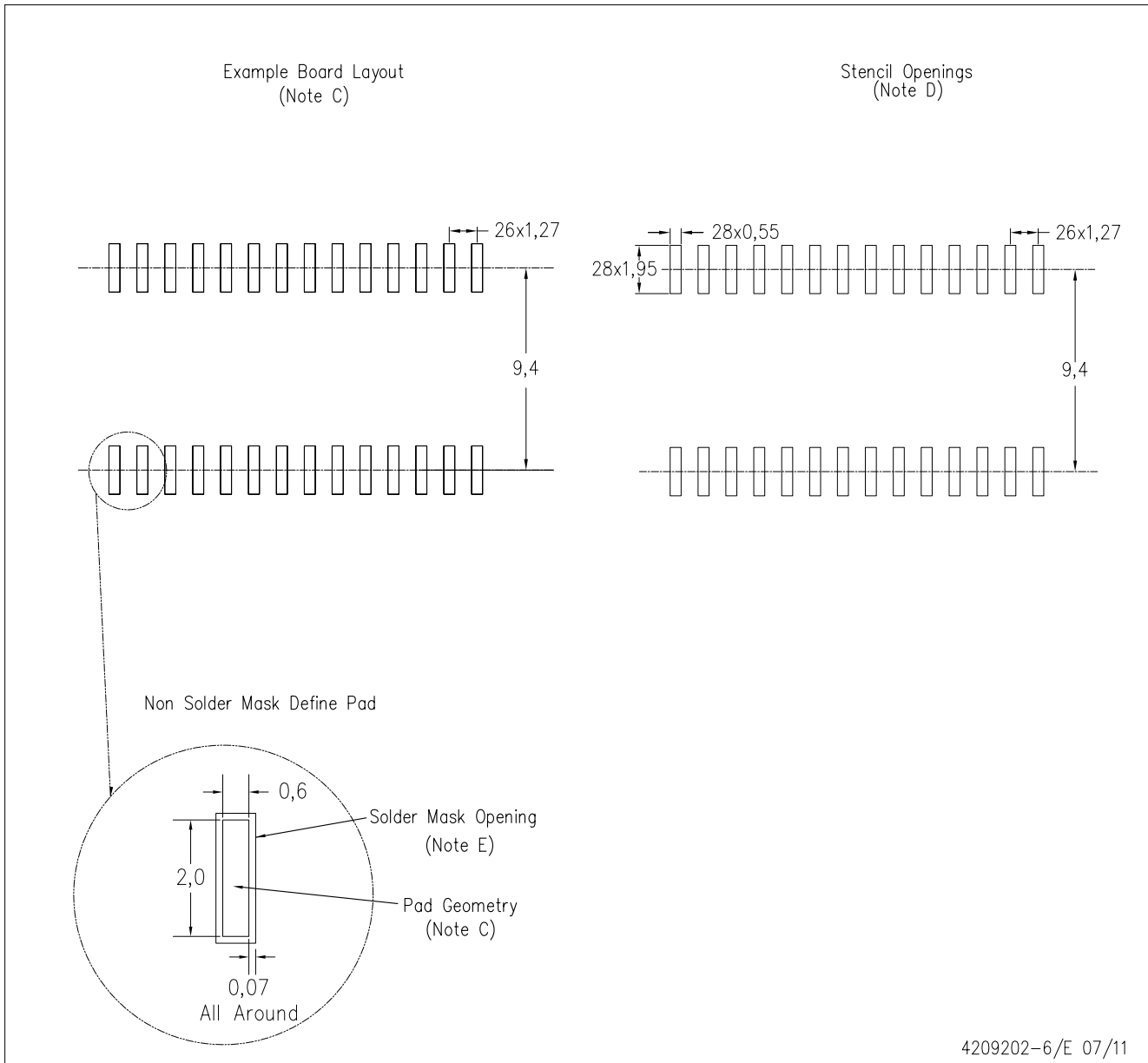

4209202-6/E 07/11

- NOTES:
- A. All linear dimensions are in millimeters.
 - B. This drawing is subject to change without notice.
 - C. Refer to IPC7351 for alternate board design.
 - D. Laser cutting apertures with trapezoidal walls and also rounding corners will offer better paste release. Customers should contact their board assembly site for stencil design recommendations. Refer to IPC-7525
 - E. Customers should contact their board fabrication site for solder mask tolerances between and around signal pads.

MECHANICAL DATA

PW (R-PDSO-G28)

PLASTIC SMALL OUTLINE

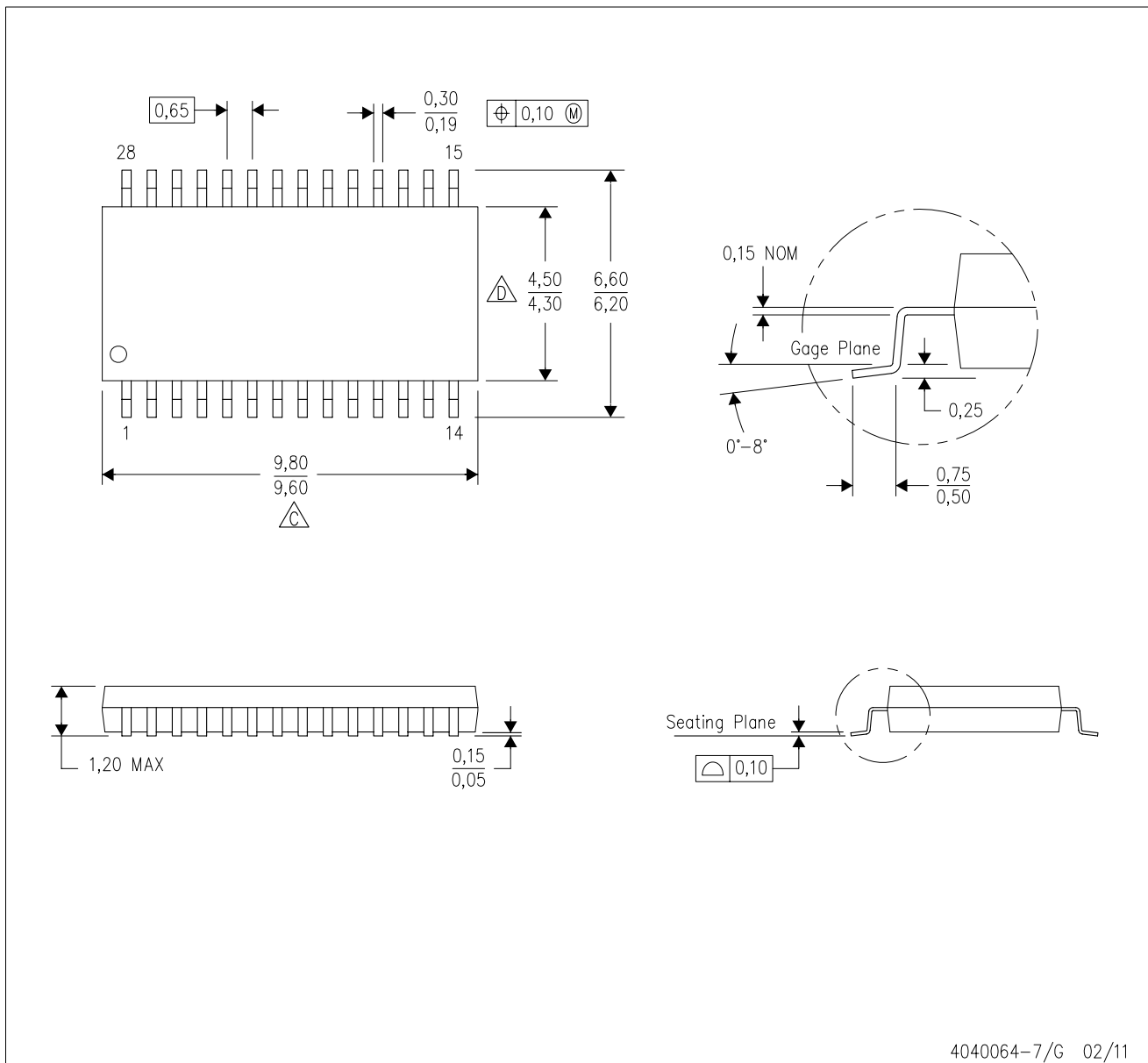

4040064-7/G 02/11

- NOTES:
- A. All linear dimensions are in millimeters. Dimensioning and tolerancing per ASME Y14.5M-1994.
 - B. This drawing is subject to change without notice.
 - C. Body length does not include mold flash, protrusions, or gate burrs. Mold flash, protrusions, or gate burrs shall not exceed 0,15 each side.
 - D. Body width does not include interlead flash. Interlead flash shall not exceed 0,25 each side.
 - E. Falls within JEDEC MO-153

PW (R-PDSO-G28)

PLASTIC SMALL OUTLINE

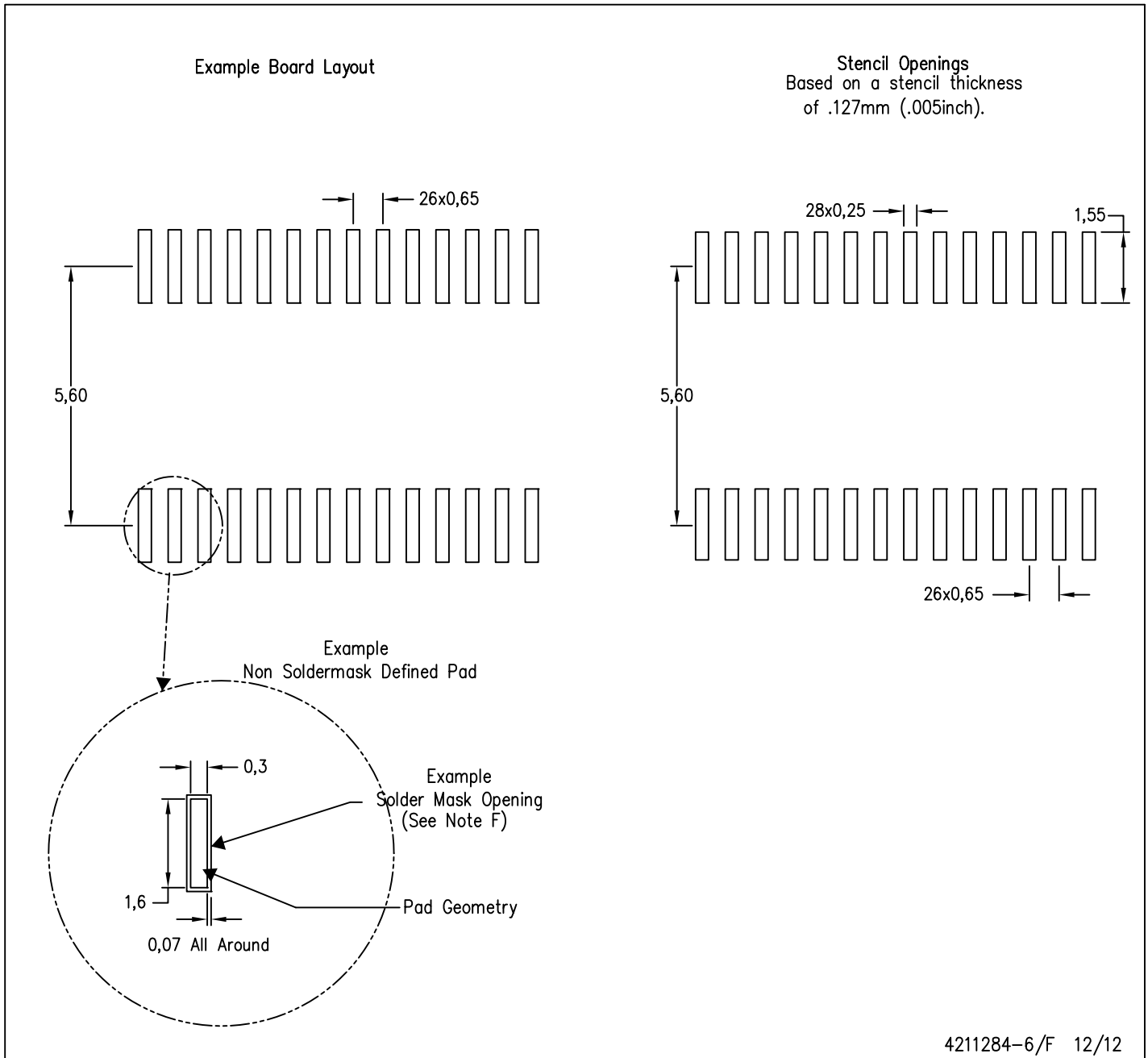

- NOTES:
- A. All linear dimensions are in millimeters.
 - B. This drawing is subject to change without notice.
 - C. Publication IPC-7351 is recommended for alternate design.
 - D. Laser cutting apertures with trapezoidal walls and also rounding corners will offer better paste release. Customers should contact their board assembly site for stencil design recommendations. Refer to IPC-7525 for other stencil recommendations.
 - E. Customers should contact their board fabrication site for solder mask tolerances between and around signal pads.

PW (R-PDSO-G28)

PLASTIC SMALL OUTLINE

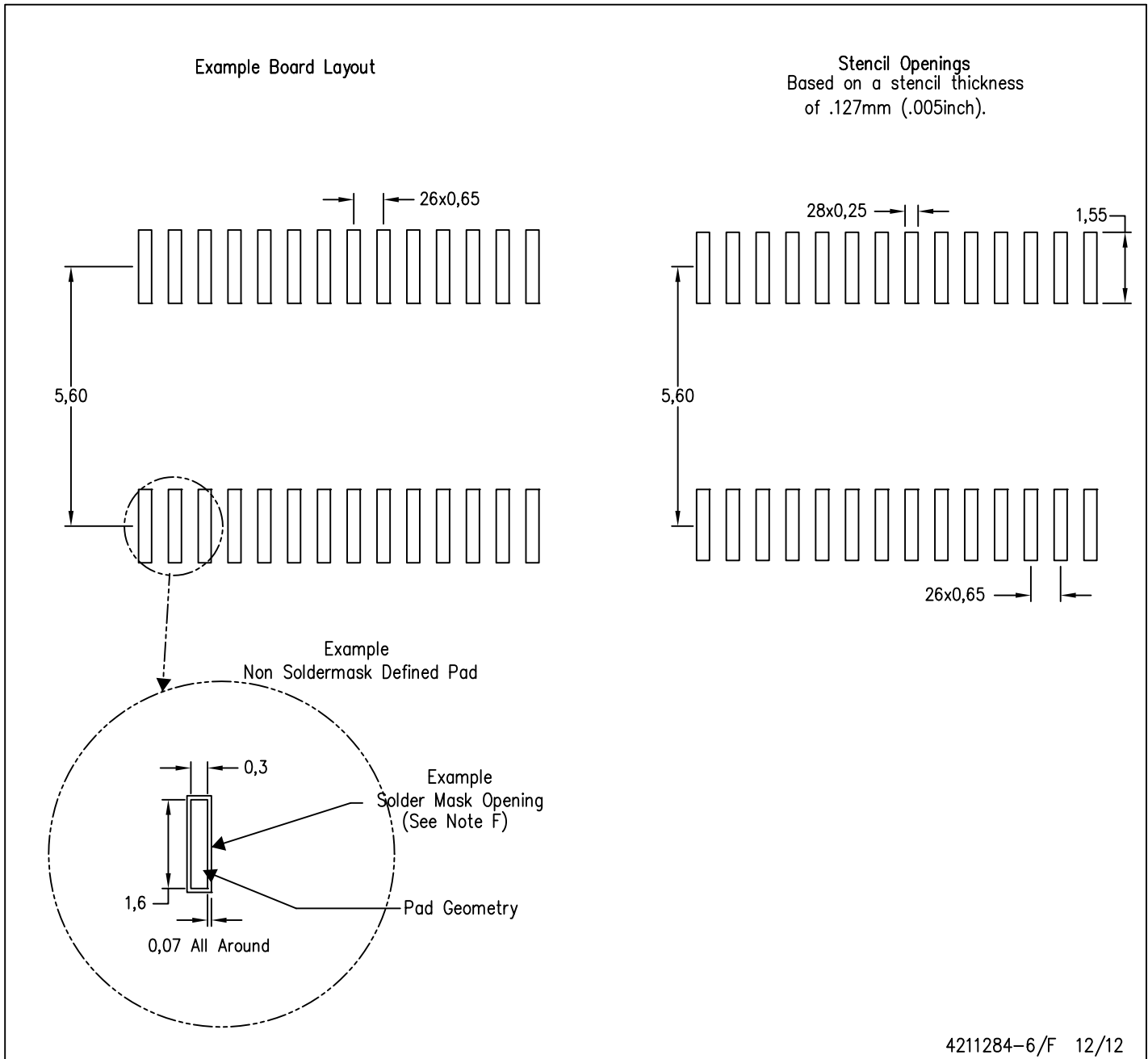

- NOTES:
- A. All linear dimensions are in millimeters.
 - B. This drawing is subject to change without notice.
 - C. Publication IPC-7351 is recommended for alternate design.
 - D. Laser cutting apertures with trapezoidal walls and also rounding corners will offer better paste release. Customers should contact their board assembly site for stencil design recommendations. Refer to IPC-7525 for other stencil recommendations.
 - E. Customers should contact their board fabrication site for solder mask tolerances between and around signal pads.

IMPORTANT NOTICE

Texas Instruments Incorporated and its subsidiaries (TI) reserve the right to make corrections, enhancements, improvements and other changes to its semiconductor products and services per JESD46, latest issue, and to discontinue any product or service per JESD48, latest issue. Buyers should obtain the latest relevant information before placing orders and should verify that such information is current and complete. All semiconductor products (also referred to herein as "components") are sold subject to TI's terms and conditions of sale supplied at the time of order acknowledgment.

TI warrants performance of its components to the specifications applicable at the time of sale, in accordance with the warranty in TI's terms and conditions of sale of semiconductor products. Testing and other quality control techniques are used to the extent TI deems necessary to support this warranty. Except where mandated by applicable law, testing of all parameters of each component is not necessarily performed.

TI assumes no liability for applications assistance or the design of Buyers' products. Buyers are responsible for their products and applications using TI components. To minimize the risks associated with Buyers' products and applications, Buyers should provide adequate design and operating safeguards.

TI does not warrant or represent that any license, either express or implied, is granted under any patent right, copyright, mask work right, or other intellectual property right relating to any combination, machine, or process in which TI components or services are used. Information published by TI regarding third-party products or services does not constitute a license to use such products or services or a warranty or endorsement thereof. Use of such information may require a license from a third party under the patents or other intellectual property of the third party, or a license from TI under the patents or other intellectual property of TI.

Reproduction of significant portions of TI information in TI data books or data sheets is permissible only if reproduction is without alteration and is accompanied by all associated warranties, conditions, limitations, and notices. TI is not responsible or liable for such altered documentation. Information of third parties may be subject to additional restrictions.

Resale of TI components or services with statements different from or beyond the parameters stated by TI for that component or service voids all express and any implied warranties for the associated TI component or service and is an unfair and deceptive business practice. TI is not responsible or liable for any such statements.

Buyer acknowledges and agrees that it is solely responsible for compliance with all legal, regulatory and safety-related requirements concerning its products, and any use of TI components in its applications, notwithstanding any applications-related information or support that may be provided by TI. Buyer represents and agrees that it has all the necessary expertise to create and implement safeguards which anticipate dangerous consequences of failures, monitor failures and their consequences, lessen the likelihood of failures that might cause harm and take appropriate remedial actions. Buyer will fully indemnify TI and its representatives against any damages arising out of the use of any TI components in safety-critical applications.

In some cases, TI components may be promoted specifically to facilitate safety-related applications. With such components, TI's goal is to help enable customers to design and create their own end-product solutions that meet applicable functional safety standards and requirements. Nonetheless, such components are subject to these terms.

No TI components are authorized for use in FDA Class III (or similar life-critical medical equipment) unless authorized officers of the parties have executed a special agreement specifically governing such use.

Only those TI components which TI has specifically designated as military grade or "enhanced plastic" are designed and intended for use in military/aerospace applications or environments. Buyer acknowledges and agrees that any military or aerospace use of TI components which have **not** been so designated is solely at the Buyer's risk, and that Buyer is solely responsible for compliance with all legal and regulatory requirements in connection with such use.

TI has specifically designated certain components as meeting ISO/TS16949 requirements, mainly for automotive use. In any case of use of non-designated products, TI will not be responsible for any failure to meet ISO/TS16949.

Products

Audio	www.ti.com/audio
Amplifiers	amplifier.ti.com
Data Converters	dataconverter.ti.com
DLP® Products	www.dlp.com
DSP	dsp.ti.com
Clocks and Timers	www.ti.com/clocks
Interface	interface.ti.com
Logic	logic.ti.com
Power Mgmt	power.ti.com
Microcontrollers	microcontroller.ti.com
RFID	www.ti-rfid.com
OMAP Applications Processors	www.ti.com/omap
Wireless Connectivity	www.ti.com/wirelessconnectivity

Applications

Automotive and Transportation	www.ti.com/automotive
Communications and Telecom	www.ti.com/communications
Computers and Peripherals	www.ti.com/computers
Consumer Electronics	www.ti.com/consumer-apps
Energy and Lighting	www.ti.com/energy
Industrial	www.ti.com/industrial
Medical	www.ti.com/medical
Security	www.ti.com/security
Space, Avionics and Defense	www.ti.com/space-avionics-defense
Video and Imaging	www.ti.com/video

TI E2E Community

e2e.ti.com