

## 3.3 V FULL-DUPLEX RS-485 DRIVERS AND RECEIVERS

Check for Samples: [SN65HVD30 – SN65HVD35](#)

### FEATURES

- 1/8 Unit-Load Option Available (Up to 256 Nodes on the Bus)
- Bus-Pin ESD Protection Exceeds 15 kV HBM
- Optional Driver Output Transition Times for Signaling Rates<sup>(1)</sup> of 1 Mbps, 5 Mbps and 26 Mbps
- Low-Current Standby Mode: < 1  $\mu$ A
- Glitch-Free Power-Up and Power-Down Protection for Hot-Plugging Applications
- 5-V Tolerant Inputs
- Bus Idle, Open, and Short Circuit Failsafe
- Driver Current Limiting and Thermal Shutdown
- Designed for RS-422 and RS-485 Networks
- 5-V Devices available, SN65HVD50-55

<sup>(1)</sup> Line Signaling Rate is the number of voltage transitions made per second expressed in units of bps (bits per second).

### APPLICATIONS

- Utility Meters
- DTE/DCE Interfaces
- Industrial, Process, and Building Automation
- Point-of-Sale (POS) Terminals and Networks

### IMPROVED REPLACEMENT FOR:

Part Number	Replace with	
xxx3491 xxx3490	SN65HVD33: SN65HVD30:	Better ESD protection (15kV vs 2kV or not specified) Higher Signaling Rate (26Mbps vs 20Mbps) Fractional Unit Load (64 Nodes vs 32)
MAX3491E MAX3490E	SN65HVD33: SN65HVD30:	Higher Signaling Rate (26Mbps vs 12Mbps) Fractional Unit Load (64 Nodes vs 32)
MAX3076E MAX3077E	SN65HVD33: SN65HVD30:	Higher Signaling Rate (26Mbps vs 16Mbps) Lower Standby Current (1 $\mu$ A vs 10 $\mu$ A)
MAX3073E MAX3074E	SN65HVD34: SN65HVD31:	Higher Signaling Rate (5Mbps vs 500kbps) Lower Standby Current (1 $\mu$ A vs 10 $\mu$ A)
MAX3070E MAX3071E	SN65HVD35: SN65HVD32:	Higher Signaling Rate (1Mbps vs 250kbps) Lower Standby Current (1 $\mu$ A vs 10 $\mu$ A)

### DESCRIPTION

The SN65HVD3X devices are 3-state differential line drivers and differential-input line receivers that operate with 3.3-V power supply.

Each driver and receiver has separate input and output pins for full-duplex bus communication designs. They are designed for RS-422 and RS-485 data transmission over cable lengths of up to 1500 meters.

The SN65HVD30, SN65HVD31, and SN65HVD32 are fully enabled with no external enabling pins.

The SN65HVD33, SN65HVD34, and SN65HVD35 have active-high driver enables and active-low receiver enables. A low, less than 1 $\mu$ A, standby current can be achieved by disabling both the driver and receiver.

All devices are characterized for ambient temperatures from  $-40^{\circ}\text{C}$  to  $85^{\circ}\text{C}$ . Low power dissipation allows operation at temperatures up to  $105^{\circ}\text{C}$  or  $125^{\circ}\text{C}$ , depending on package option.



Please be aware that an important notice concerning availability, standard warranty, and use in critical applications of Texas Instruments semiconductor products and disclaimers thereto appears at the end of this data sheet.

# SN65HVD30 – SN65HVD35

SLLS665I – SEPTEMBER 2005 – REVISED APRIL 2010

www.ti.com



This integrated circuit can be damaged by ESD. Texas Instruments recommends that all integrated circuits be handled with appropriate precautions. Failure to observe proper handling and installation procedures can cause damage.

ESD damage can range from subtle performance degradation to complete device failure. Precision integrated circuits may be more susceptible to damage because very small parametric changes could cause the device not to meet its published specifications.

## SN65HVD30, SN65HVD31, SN65HVD32

D PACKAGE (TOP VIEW)

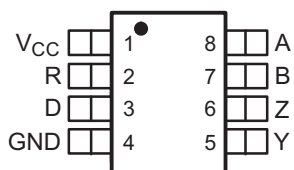

## SN65HVD33, SN65HVD34, SN65HVD35

D PACKAGE (TOP VIEW)

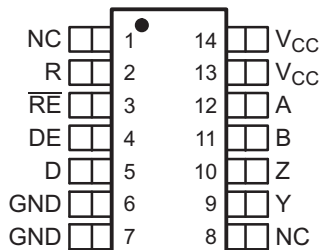

NC - No internal connection  
Pins 6 and 7 are connected together internally  
Pins 13 and 14 are connected together internally

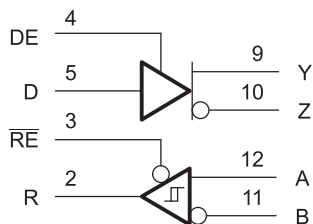

## SN65HVD33

RHL PACKAGE (TOP VIEW)

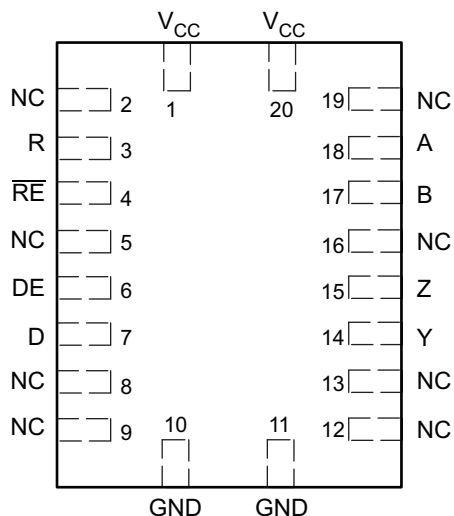

NC - No internal connection  
Pins 10 and 11 are connected together internally  
Pins 1 and 20 are connected together internally

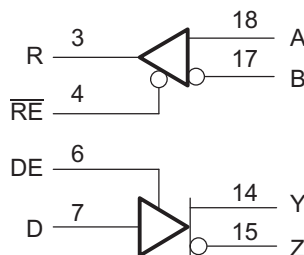

**AVAILABLE OPTIONS**

SIGNALING RATE	UNIT LOADS	ENABLES	BASE PART NUMBER	SOIC MARKING
26 Mbps	1/2	No	SN65HVD30	VP30
5 Mbps	1/8	No	SN65HVD31	VP31
1 Mbps	1/8	No	SN65HVD32	VP32
26 Mbps	1/2	Yes	SN65HVD33	65HVD33
5 Mbps	1/8	Yes	SN65HVD34	65HVD34
1 Mbps	1/8	Yes	SN65HVD35	65HVD35

**ABSOLUTE MAXIMUM RATINGS**

 over operating free-air temperature range unless otherwise noted<sup>(1)</sup> <sup>(2)</sup>

		UNIT
$V_{CC}$	Supply voltage range	–0.3 V to 6 V
$V_{(A)}, V_{(B)}, V_{(Y)}, V_{(Z)}$	Voltage range at any bus terminal (A, B, Y, Z)	–9 V to 14 V
$V_{(TRANS)}$	Voltage input, transient pulse through 100 $\Omega$ . See <a href="#">Figure 12</a> (A, B, Y, Z) <sup>(3)</sup>	–50 to 50 V
$V_I$	Input voltage range (D, DE, $\overline{RE}$ )	–0.5 V to 7 V
$I_O$	Output current (receiver output only, R)	11 mA

- (1) Stresses beyond those listed under absolute maximum ratings may cause permanent damage to the device. These are stress ratings only, and functional operation of the device at these or any other conditions beyond those indicated under recommended operating conditions is not implied. Exposure to absolute-maximum-rated conditions for extended periods may affect device reliability.
- (2) All voltage values, except differential I/O bus voltages, are with respect to network ground terminal.
- (3) This tests survivability only and the output state of the receiver is not specified.

**DISSIPATION RATINGS**

PACKAGE	JEDEC THERMAL MODEL	$T_A < 25^\circ\text{C}$ RATING	DERATING FACTOR ABOVE $T_A = 25^\circ\text{C}$	$T_A = 85^\circ\text{C}$ RATING	$T_A = 105^\circ\text{C}$ RATING	$T_A = 125^\circ\text{C}$ RATING
SOIC (D) 8 pin	Low k	625 mW	5 mW/ $^\circ\text{C}$	325 mW		
	High k	1000 mW	8 mW/ $^\circ\text{C}$	520 mW	360 mW	
SOIC (D) 14 pin	Low k	765 mW	6.1 mW/ $^\circ\text{C}$	400 mW	275 mW	
	High k	1350 mW	10.8 mW/ $^\circ\text{C}$	705 mW	485 mW	270 mW
QFN (RHL) 20 pin	High k	1710 mW	13.7 mW/ $^\circ\text{C}$	890 mW	6150 mW	340 mW

# SN65HVD30 – SN65HVD35

SLLS665I – SEPTEMBER 2005 – REVISED APRIL 2010

[www.ti.com](http://www.ti.com)

## RECOMMENDED OPERATING CONDITIONS

over operating free-air temperature range unless otherwise noted

		MIN	NOM	MAX	UNIT
$V_{CC}$	Supply voltage	3		3.6	V
$V_I$ or $V_{IC}$	Voltage at any bus terminal (separately or common mode)	$-7^{(1)}$		12	
$1/t_{UI}$	Signaling rate	SN65HVD30, SN65HVD33		26	Mbps
		SN65HVD31, SN65HVD34		5	
		SN65HVD32, SN65HVD35		1	
$R_L$	Differential load resistance	54	60		$\Omega$
$V_{IH}$	High-level input voltage	D, DE, $\overline{RE}$		$V_{CC}$	V
$V_{IL}$	Low-level input voltage	D, DE, $\overline{RE}$		0.8	
$V_{ID}$	Differential input voltage	$-12$		12	
$I_{OH}$	High-level output current	Driver		$-60$	mA
		Receiver		$-8$	
$I_{OL}$	Low-level output current	Driver		60	mA
		Receiver		8	
$T_J$	Junction temperature	$-40$		150	$^{\circ}\text{C}$

(1) The algebraic convention, in which the least positive (most negative) limit is designated as minimum is used in this data sheet.

## ELECTROSTATIC DISCHARGE PROTECTION

PARAMETER	TEST CONDITIONS	MIN	TYP <sup>(1)</sup>	MAX	UNIT
Human body model	Bus terminals and GND		$\pm 16$		kV
Human body model <sup>(2)</sup>	All pins		$\pm 4$		
Charged-device-model <sup>(3)</sup>	All pins		$\pm 1$		

(1) All typical values at 25°C with 3.3-V supply.

(2) Tested in accordance with JEDEC Standard 22, Test Method A114-A.

(3) Tested in accordance with JEDEC Standard 22, Test Method C101.

**DRIVER ELECTRICAL CHARACTERISTICS**

over recommended operating conditions unless otherwise noted

PARAMETER		TEST CONDITIONS		MIN	TYP <sup>(1)</sup>	MAX	UNIT		
$V_{I(K)}$	Input clamp voltage	$I_I = -18 \text{ mA}$		-1.5			V		
$ V_{OD(SS)} $	Steady-state differential output voltage	$I_O = 0$		2.5		$V_{CC}$	V		
		$R_L = 54 \Omega$ , See <a href="#">Figure 1</a> (RS-485)		1.5	2				
		$R_L = 100 \Omega$ , See <a href="#">Figure 1</a> , <sup>(2)</sup> (RS-422)		2	2.3				
		$V_{test} = -7 \text{ V to } 12 \text{ V}$ , See <a href="#">Figure 2</a>		1.5					
$\Delta V_{OD(SS)} $	Change in magnitude of steady-state differential output voltage between states	$R_L = 54 \Omega$ , See <a href="#">Figure 1</a> and <a href="#">Figure 2</a>		-0.2		0.2	V		
$V_{OD(RING)}$	Differential Output Voltage overshoot and undershoot	$R_L = 54 \Omega$ , $C_L = 50 \text{ pF}$ , See <a href="#">Figure 5</a> and <a href="#">Figure 3</a>				10% <sup>(3)</sup>	V		
$V_{OC(PP)}$	Peak-to-peak common-mode output voltage	HVD30, HVD33	See <a href="#">Figure 4</a>			0.5	V		
		HVD31, HVD34, HVD32, HVD35				0.25			
$V_{OC(SS)}$	Steady-state common-mode output voltage	See <a href="#">Figure 4</a>		1.6		2.3	V		
$\Delta V_{OC(SS)}$	Change in steady-state common-mode output voltage			-0.05		0.05			
$I_{Z(Z)}$ or $I_{Y(Z)}$	High-impedance state output current	HVD30, HVD31, HVD32		$V_{CC} = 0 \text{ V}$ , $V_Z$ or $V_Y = 12 \text{ V}$ , Other input at 0 V		90	$\mu\text{A}$		
				$V_{CC} = 0 \text{ V}$ , $V_Z$ or $V_Y = -7 \text{ V}$ , Other input at 0 V		-10			
		HVD33, HVD34, HVD35		$V_{CC} = 3 \text{ V or } 0 \text{ V}$ , $DE = 0 \text{ V}$ , $V_Z$ or $V_Y = 12 \text{ V}$		Other input at 0 V		90	
				$V_{CC} = 3 \text{ V or } 0 \text{ V}$ , $DE = 0 \text{ V}$ , $V_Z$ or $V_Y = -7 \text{ V}$		Other input at 0 V		-10	
$I_{Z(S)}$ or $I_{Y(S)}$	Short Circuit output current <sup>(4)</sup>			$V_Z$ or $V_Y = -7 \text{ V}$		-250	250	mA	
				$V_Z$ or $V_Y = 12 \text{ V}$		-250	250		
$I_I$	Input current	D, DE		0		100	$\mu\text{A}$		
$C_{(OD)}$	Differential output capacitance	$V_{OD} = 0.4 \sin(4E6\pi t) + 0.5 \text{ V}$ , DE at 0 V				16	pF		

(1) All typical values are at 25°C and with a 3.3-V supply.

(2)  $V_{CC}$  is 3.3 Vdc  $\pm$  5%

(3) 10% of the peak-to-peak differential output voltage swing, per TIA/EIA-485

(4) Under some conditions of short-circuit to negative voltages, output currents exceeding the ANSI TIA/EIA-485-A maximum current of 250 mA may occur. Continuous exposure may affect device reliability. This applies to the HVD30, HVD31, HVD33, and HVD34.

**DRIVER SWITCHING CHARACTERISTICS**

over recommended operating conditions unless otherwise noted

PARAMETER		TEST CONDITIONS	MIN	TYP <sup>(1)</sup>	MAX	UNIT
t <sub>PLH</sub>	Propagation delay time, low-to-high-level output	HVD30, HVD33	4	10	18	ns
		HVD31, HVD34	25	38	65	
		HVD32, HVD35	120	175	305	
t <sub>PHL</sub>	Propagation delay time, high-to-low-level output	HVD30, HVD33	4	9	18	ns
		HVD31, HVD34	25	38	65	
		HVD32, HVD35	120	175	305	
t <sub>r</sub>	Differential output signal rise time	HVD30, HVD33	2.5	5	12	ns
		HVD31, HVD34	20	37	60	
		HVD32, HVD35	120	185	300	
t <sub>f</sub>	Differential output signal fall time	HVD30, HVD33	2.5	5	12	ns
		HVD31, HVD34	20	35	60	
		HVD32, HVD35	120	180	300	
t <sub>sk(p)</sub>	Pulse skew ( t <sub>PHL</sub> – t <sub>PLH</sub>  )	HVD30, HVD33		0.6		ns
		HVD31, HVD34		2.0		
		HVD32, HVD35		5.1		
t <sub>PZH1</sub>	Propagation delay time, high-impedance-to-high-level output	HVD33			45	ns
		HVD34			235	
		HVD35			490	
t <sub>PHZ</sub>	Propagation delay time, high-level-to-high-impedance output	HVD33			25	ns
		HVD34			65	
		HVD35			165	
t <sub>PZL1</sub>	Propagation delay time, high-impedance-to-low-level output	HVD33			35	ns
		HVD34			190	
		HVD35			490	
t <sub>PLZ</sub>	Propagation delay time, low-level-to-high-impedance output	HVD33			30	ns
		HVD34			120	
		HVD35			290	
t <sub>PZH1</sub> , t <sub>PZL1</sub>	Driver enable delay with bus voltage offset	V <sub>O</sub> = 2 V (Typ)		500	900	ns
t <sub>PZH2</sub>	Propagation delay time, standby-to-high-level output	R <sub>L</sub> = 110 Ω, $\overline{RE}$ at 3 V, D = 3 V and S1 = Y, or D = 0 V and S1 = Z See Figure 6			4000	ns
t <sub>PZL2</sub>	Propagation delay time, standby-to-low-level output	R <sub>L</sub> = 110 Ω, $\overline{RE}$ at 3 V, D = 3 V and S1 = Z, or D = 0 V and S1 = Y See Figure 7			4000	ns

(1) All typical values are at 25°C and with a 3.3-V supply.

## RECEIVER ELECTRICAL CHARACTERISTICS

over recommended operating conditions unless otherwise noted

PARAMETER		TEST CONDITIONS	MIN	TYP <sup>(1)</sup>	MAX	UNIT	
$V_{IT+}$	Positive-going differential input threshold voltage	$I_O = -8$ mA			-0.02	V	
$V_{IT-}$	Negative-going differential input threshold voltage	$I_O = 8$ mA	-0.20				
$V_{hys}$	Hysteresis voltage ( $V_{IT+} - V_{IT-}$ )			50		mV	
$V_{IK}$	Enable-input clamp voltage	$I_I = -18$ mA	-1.5			V	
$V_O$	Output voltage	$V_{ID} = 200$ mV, $I_O = -8$ mA, See <a href="#">Figure 8</a>	2.4			V	
		$V_{ID} = -200$ mV, $I_O = 8$ mA, See <a href="#">Figure 8</a>			0.4		
$I_{O(Z)}$	High-impedance-state output current	$V_O = 0$ or $V_{CC}$ , $\overline{RE}$ at $V_{CC}$	-1		1	$\mu$ A	
$I_A$ or $I_B$	Bus input current	HVD31, HVD32, HVD34, HVD35	$V_A$ or $V_B = 12$ V	Other input at 0V	0.05	0.1	mA
			$V_A$ or $V_B = 12$ V, $V_{CC} = 0$ V		0.06	0.1	
			$V_A$ or $V_B = -7$ V		-0.10	-0.04	
			$V_A$ or $V_B = -7$ V, $V_{CC} = 0$ V		-0.10	-0.03	
	HVD30, HVD33	Other input at 0V	$V_A$ or $V_B = 12$ V	0.20	0.35	mA	
			$V_A$ or $V_B = 12$ V, $V_{CC} = 0$ V	0.24	0.4		
			$V_A$ or $V_B = -7$ V	-0.35	-0.18		
			$V_A$ or $V_B = -7$ V, $V_{CC} = 0$ V	-0.25	-0.13		
$I_{IH}$	Input current, $\overline{RE}$	$V_{IH} = 0.8$ V or 2 V	-60			$\mu$ A	
$C_{ID}$	Differential input capacitance	$V_{ID} = 0.4 \sin(4E6\pi t) + 0.5$ V, DE at 0 V		15		pF	

(1) All typical values are at 25°C and with a 3.3-V supply.

## SUPPLY CURRENT CHARACTERISTICS

over recommended operating conditions unless otherwise noted

PARAMETER		TEST CONDITIONS	MIN	TYP <sup>(1)</sup>	MAX	UNIT
$I_{CC}$	Supply current	D at 0 V or $V_{CC}$ and No Load			2.1	mA
				3.8	6.4	
	HVD33	$\overline{RE}$ at 0 V, D at 0 V or $V_{CC}$ , DE at 0 V, No load (Receiver enabled and driver disabled)			1.8	mA
					2.2	
	HVD33, HVD34, HVD35	$\overline{RE}$ at $V_{CC}$ , D at $V_{CC}$ , DE at 0 V, No load (Receiver disabled and driver disabled)	0.022		1	$\mu$ A
	HVD33	$\overline{RE}$ at 0 V, D at 0 V or $V_{CC}$ , DE at $V_{CC}$ , No load (Receiver enabled and driver enabled)			2.1	mA
					6.5	
HVD33	$\overline{RE}$ at $V_{CC}$ , D at 0 V or $V_{CC}$ , DE at $V_{CC}$ , No load (Receiver disabled and driver enabled)			1.8	mA	
				6.2		

(1) All typical values are at 25°C and with a 3.3-V supply.

# SN65HVD30 – SN65HVD35

SLLS665I – SEPTEMBER 2005 – REVISED APRIL 2010

[www.ti.com](http://www.ti.com)

## RECEIVER SWITCHING CHARACTERISTICS

over recommended operating conditions unless otherwise noted

PARAMETER		TEST CONDITIONS	MIN	TYP <sup>(1)</sup>	MAX	UNIT
t <sub>PLH</sub>	Propagation delay time, low-to-high-level output	HVD30, HVD33		26	45	ns
		HVD31, HVD32, HVD34, HVD35		47	70	
t <sub>PHL</sub>	Propagation delay time, high-to-low-level output	HVD30, HVD33	V <sub>ID</sub> = -1.5 V to 1.5 V, C <sub>L</sub> = 15 pF, See <a href="#">Figure 9</a>	29	45	
		HVD31, HVD32, HVD34, HVD35		49	70	
t <sub>sk(p)</sub>	Pulse skew ( t <sub>PHL</sub> – t <sub>PLH</sub>  )	HVD30, HVD33		7		
		HVD31, HVD34, HVD32, HVD35		10		
t <sub>r</sub>	Output signal rise time			5		
t <sub>f</sub>	Output signal fall time			6		
t <sub>PHZ</sub>	Output disable time from high level	DE at 3 V		C <sub>L</sub> = 15 pF, See <a href="#">Figure 10</a>	20	
t <sub>PZH1</sub>	Output enable time to high level				20	
t <sub>PZH2</sub>	Propagation delay time, standby-to-high-level output	DE at 0 V			4000	
t <sub>PLZ</sub>	Output disable time from low level	DE at 3 V		C <sub>L</sub> = 15 pF, See <a href="#">Figure 11</a>	20	
t <sub>PZL1</sub>	Output enable time to low level				20	
t <sub>PZL2</sub>	Propagation delay time, standby-to-low-level output	DE at 0 V			4000	

(1) All typical values are at 25°C and with a 3.3-V supply

## DEVICE POWER DISSIPATION – P<sub>D</sub>

PARAMETER		TEST CONDITIONS	VALUE	UNITS		
θ <sub>JA</sub>	Junction-to-Ambient Thermal Resistance	SOIC-8	JEDEC Low-K model	231	°C/W	
			JEDEC High-K model	135		
		SOIC-14	JEDEC Low-K model	163		
			JEDEC High-K model	92		
	QFN-20		73			
θ <sub>JB</sub>	Junction-to- Board Thermal Resistance	SOIC-8	44	°C/W		
		SOIC-14	61			
		QFN-20				
θ <sub>JC</sub>	Junction-to-Case Thermal Resistance	SOIC-8	43	°C/W		
		SOIC-14	59			
		QFN-20	14			
P <sub>D</sub>	Power Dissipation Driver and receiver enabled, 50% duty cycle square-wave signal at signaling rate: HVD30,33 at 25 Mbps, HVD31,34 at 5 Mbps, HVD32,35 at 1 Mbps	Typical	HVD30,33	V <sub>CC</sub> = 3.3V, T <sub>J</sub> = 25°C, R <sub>L</sub> = 60 Ω, C <sub>L</sub> = 50 pF (driver), C <sub>L</sub> = 15 pF (receiver)	mW	
			HVD31,34			
			HVD32,35			
		Worst-case	HVD30,33		197	mW
			HVD31,34		213	
			HVD32,35		248	
T <sub>SD</sub>	Thermal Shut-down Junction Temperature		170	°C		



PARAMETER MEASUREMENT INFORMATION

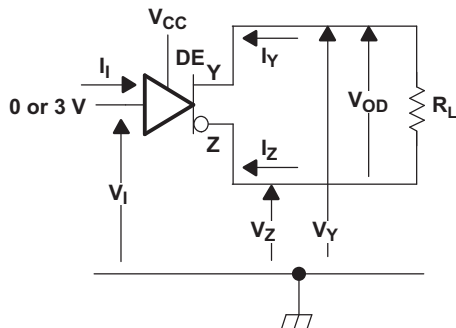

Figure 1. Driver  $V_{OD}$  Test Circuit and Voltage and Current Definitions

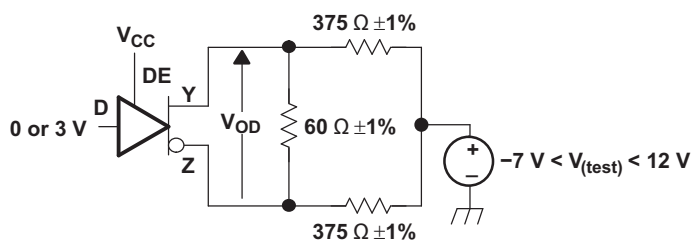

Figure 2. Driver  $V_{OD}$  With Common-Mode Loading Test Circuit

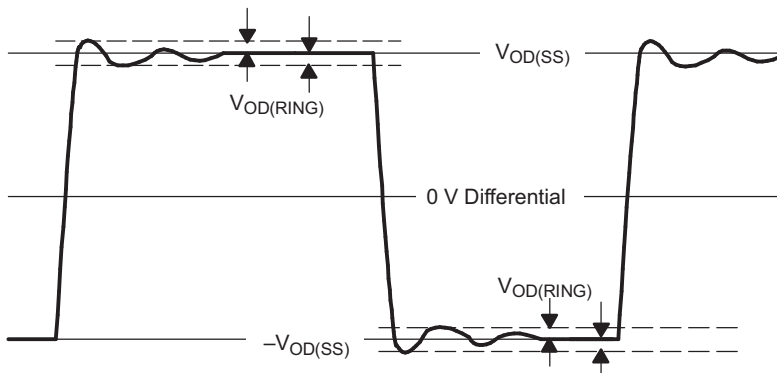

Figure 3.  $V_{OD(RING)}$  Waveform and Definitions

$V_{OD(RING)}$  is measured at four points on the output waveform, corresponding to overshoot and undershoot from the  $V_{OD(H)}$  and  $V_{OD(L)}$  steady state values.

PARAMETER MEASUREMENT INFORMATION (continued)

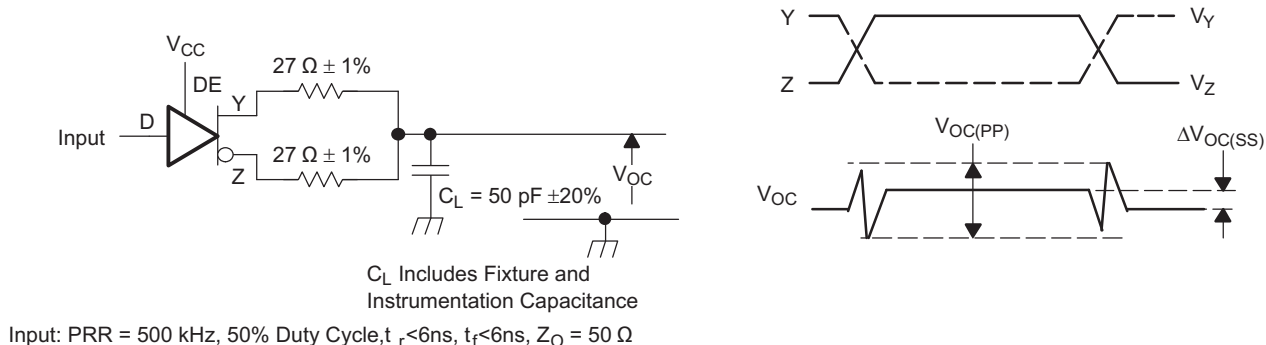

Figure 4. Test Circuit and Definitions for the Driver Common-Mode Output Voltage

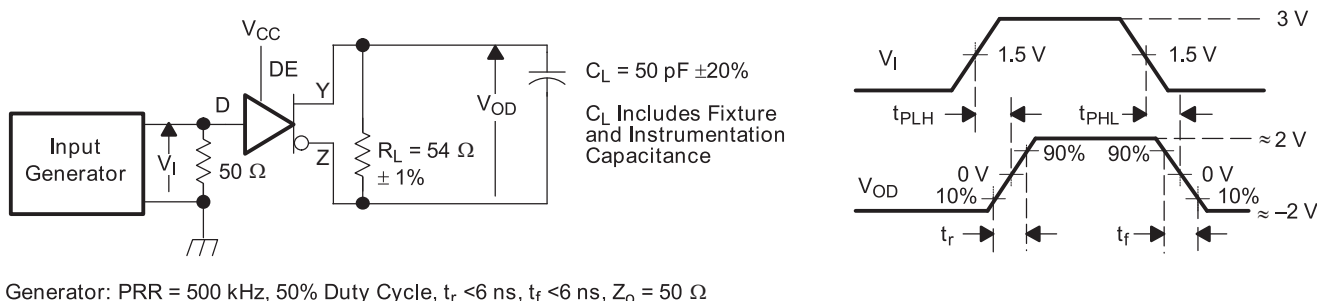

Figure 5. Driver Switching Test Circuit and Voltage Waveforms

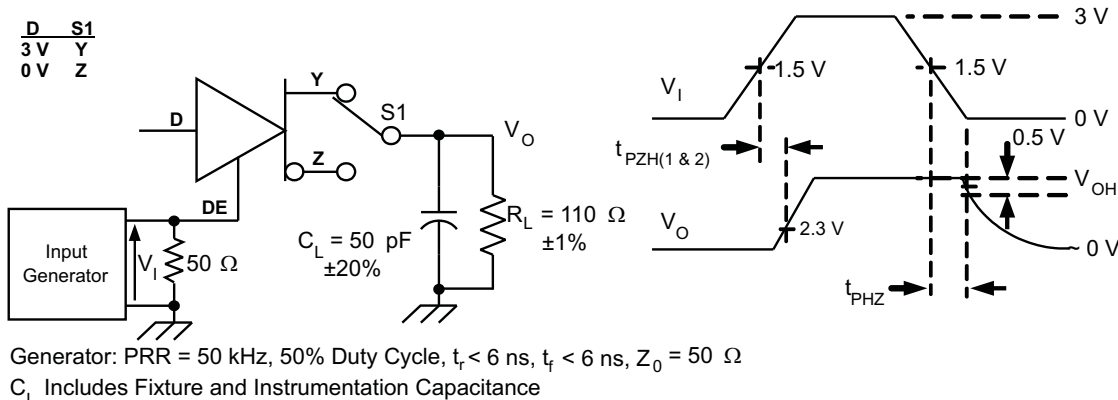
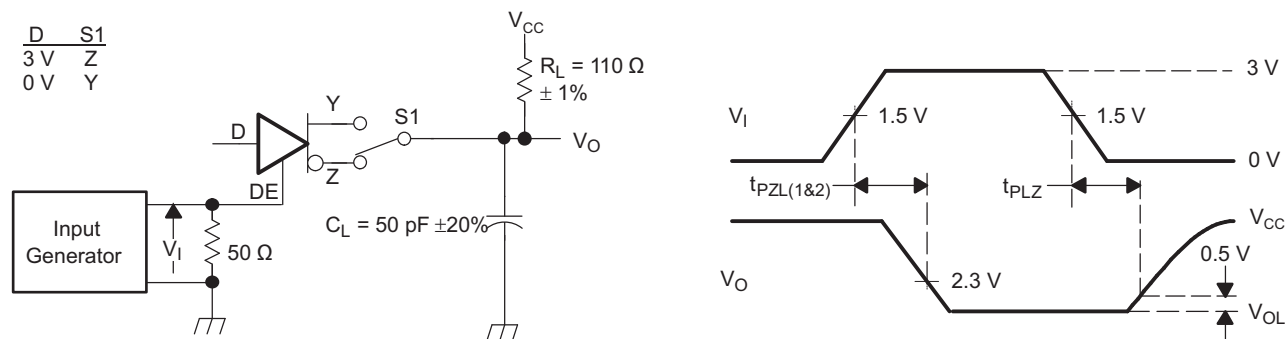

Figure 6. Driver High-Level Output Enable and Disable Time Test Circuit and Voltage Waveforms

PARAMETER MEASUREMENT INFORMATION (continued)



Generator: PRR = 50 kHz, 50% Duty Cycle,  $t_r < 6$  ns,  $t_f < 6$  ns,  $Z_0 = 50 \Omega$

$C_L$  Includes Fixture and Instrumentation Capacitance

Figure 7. Driver Low-Level Output Enable and Disable Time Test Circuit and Voltage Waveforms

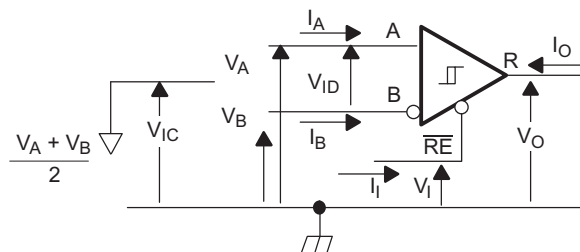
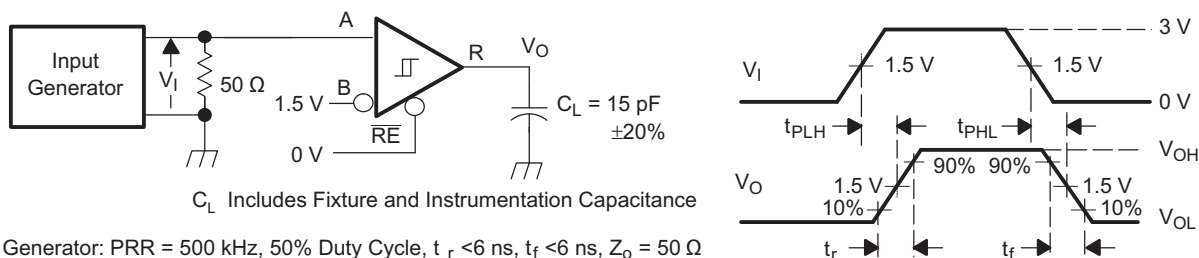
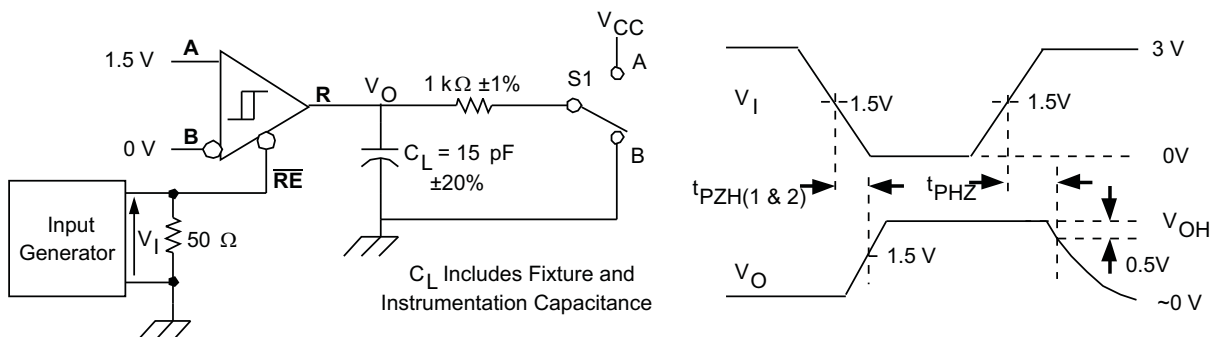

Figure 8. Receiver Voltage and Current Definitions



Generator: PRR = 500 kHz, 50% Duty Cycle,  $t_r < 6$  ns,  $t_f < 6$  ns,  $Z_0 = 50 \Omega$

Figure 9. Receiver Switching Test Circuit and Voltage Waveforms



Generator: PRR = 50 kHz, 50% Duty Cycle,  $t_r < 6$  ns,  $t_f < 6$  ns,  $Z_0 = 50 \Omega$

Figure 10. Receiver High-Level Enable and Disable Time Test Circuit and Voltage Waveforms

PARAMETER MEASUREMENT INFORMATION (continued)

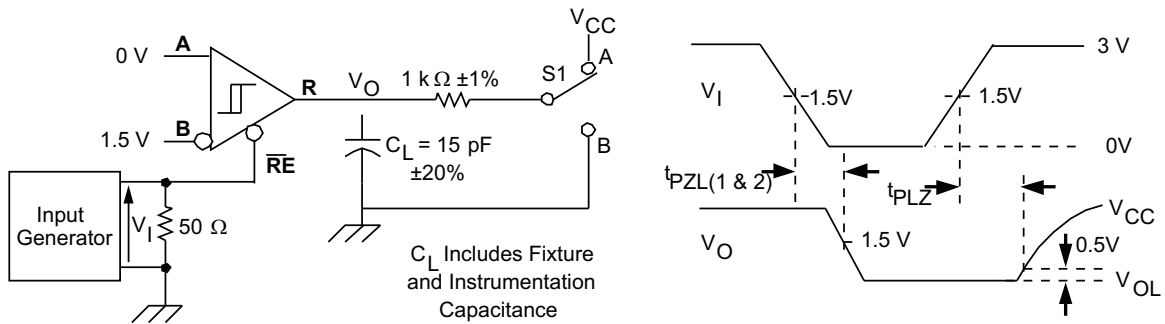

Generator: PRR = 50 kHz, 50% Duty Cycle,  $t_r < 6$  ns,  $t_f < 6$  ns,  $Z_0 = 50 \Omega$

Figure 11. Receiver Enable Time From Standby (Driver Disabled)

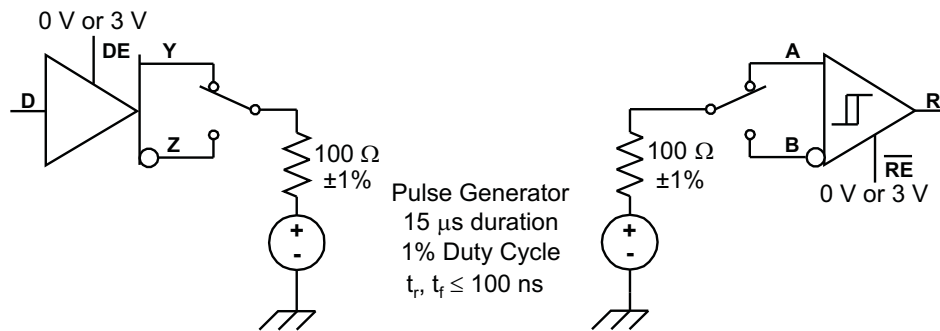
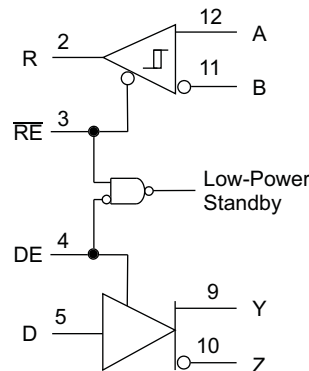

Figure 12. Test Circuit, Transient Over Voltage Test

## DEVICE INFORMATION

### LOW-POWER STANDBY MODE

When both the driver and receiver are disabled ( $\overline{DE}$  low and  $\overline{RE}$  high) the device is in standby mode. If the enable inputs are in this state for less than 60 ns, the device does not enter standby mode. This guards against inadvertently entering standby mode during driver/receiver enabling. Only when the enable inputs are held in this state for 300 ns or more, the device is assured to be in standby mode. In this low-power standby mode, most internal circuitry is powered down, and the supply current is typically less than 1 nA. When either the driver or the receiver is re-enabled, the internal circuitry becomes active.



**Figure 13. Low-Power Standby Logic Diagram**

If only the driver is re-enabled ( $\overline{DE}$  transitions to high) the driver outputs are driven according to the D input after the enable times given by  $t_{PZH2}$  and  $t_{PZL2}$  in the driver switching characteristics. If the D input is open when the driver is enabled, the driver outputs default to A high and B low, in accordance with the driver failsafe feature.

If only the receiver is re-enabled ( $\overline{RE}$  transitions to low) the receiver output is driven according to the state of the bus inputs (A and B) after the enable times given by  $t_{PZH2}$  and  $t_{PZL2}$  in the receiver switching characteristics. If there is no valid state on the bus the receiver responds as described in the failsafe operation section.

If both the receiver and driver are re-enabled simultaneously, the receiver output is driven according to the state of the bus inputs (A and B) and the driver output is driven according to the D input. Note that the state of the active driver affects the inputs to the receiver. Therefore, the receiver outputs are valid as soon as the driver outputs are valid.

### DRIVER OUTPUT CURRENT LIMITING

The RS-485 standard (ANSI/TIA/EIA-485-A or equivalently ISO 8482) specifies a 250 mA driver output current limit to prevent damage caused by data contention on the bus. That applies in the event that two or more transceivers drive the bus to opposing states at the same time. The HVD3x family of devices includes current limiting circuitry that prevents damage under these conditions. Note that this current limit prevents damage during the bus contention, but the logic state of the bus may be indeterminate as specified by the standard, so communication errors may occur.

In a specific combination of circumstances, a condition may occur in which current through the bus pin exceeds the 250 mA limit. This combination of conditions is not normally included in RS-485 applications:

- *loading capacitance on the pin is less than 500 pF*
- *the bus pin is directly connected to a voltage more negative than -1V*
- *the device is supplied with  $V_{CC}$  equal or greater than 3.3V*
- *the driver is enabled*
- *the bus pin is driving to the logic high state.*

In these specific conditions, the normal current limit circuitry and thermal shutdown circuitry will not limit or shutdown the current flow. If the current is allowed to continue, the device will heat up in a localized area near the driver outputs, and the device may be damaged.

Typical RS-485 twisted-pair cable has capacitance of approximately 50 pF/meter. Therefore it is expected that 10 meters of cable would provide sufficient capacitance to prevent this latch-up condition.

The  $-7$  to  $+12$ V common mode range specified by RS-485 is intended to allow communication between transceivers separated by significant distances, when ground offsets may occur due to temporary current surges, electrical noise, etc. In those circumstances, the inherent cable needed to connect separated transceivers will ensure that the conditions above do not occur. For transceiver separated by only a short cable length, or backplane applications, it would be unusual for there to be a steady-state negative common-mode voltage. It is possible for a negative power supply to be shorted to the bus lines due to mis-wiring or cable damage, however, this is a different root cause fault, and robust devices such as the HVD178x family should be used for surviving power supply or mis-wiring faults.

The 250 mA current limit in the RS-485 standard is intended to prevent damage caused by data contention on the bus; that is, in the event that two or more transceivers drive the bus to different states at the same time. These devices will not be damaged under these conditions, because all RS-485 drivers have output impedance sufficient to prevent the direct connection condition stated above. Typical RS-485 driver output impedance is on the order of 10 to 30  $\Omega$ .

## HOT-PLUGGING

These devices are designed to operate in *hot swap* or *hot pluggable* applications. Key features for hot-pluggable applications are power-up, power-down glitch-free operation, default disabled input/output pins, and receiver failsafe. As shown in [Figure 24](#), an internal Power-On Reset circuit keeps the driver outputs in a high-impedance state until the supply voltage has reached a level at which the device will reliably operate. This ensures that no spurious bits are transmitted on the bus pin outputs as the power supply turns on or turns off.

As shown in the device FUNCTION TABLES, the enable inputs have the feature of default disable on both the driver enable and receiver enable. This ensures that the device will neither drive the bus nor report data on the R pin until the associated controller actively drives the enable pins.

## RECEIVER FAILSAFE

The differential receiver is *failsafe* to invalid bus states caused by open bus conditions such as, a disconnected connector, shorted bus conditions caused by damaged cabling, or idle bus conditions that occur when no driver is actively driving a valid RD-485 bus state on the network. In any of these cases, the differential receiver will output a failsafe HIGH state, so that small noise signals do not cause spurious transitions at the receiver output.

## SAFE OPERATION WITH BUS CONTENTION

These devices incorporate a driver current limit of 250 mA across the RS-485 common-mode range of  $-7$  V to  $+12$  V. As stated in the "*Application Guidelines for TIA/EIA-485-A*" <sup>(1)</sup> this sets a practical limitation to prevent damage during bus contention events. Contention can occur during system initialization, during system faults, or whenever two or more drivers are active at the same time.

[Figure 14](#) shows a 2-node system to demonstrate bus contention by forcing both drivers to be active in opposing states.

(1) TIA/EIA Telecommunications System Bulletin TSB89, "Application Guidelines for TIA/EIA-485-A"

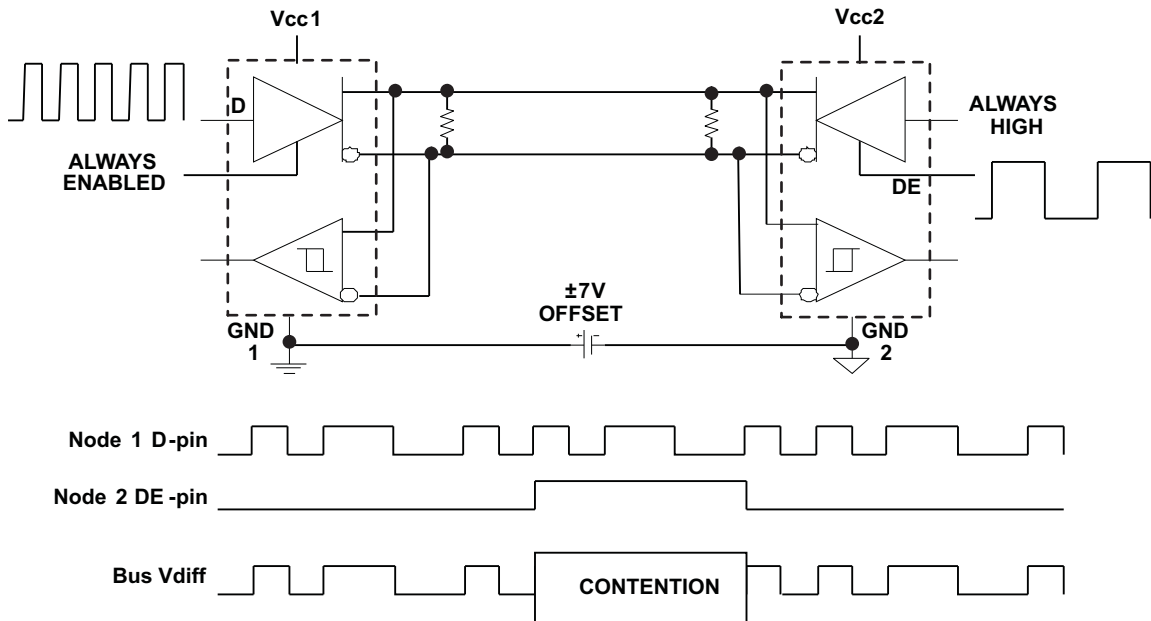

Figure 14. Bus Contention Example

Figure 15 shows typical operation in a bus contention event. The bottom trace illustrates how the SN65HVD33 at Node 1 continues normal operation after a contention event between the two drivers, with a  $-7\text{ V}$  ground offset on Node 2. This illustrates how the HVD3x family of devices operates robustly in spite of bus contention faults, even with large common-mode offsets.

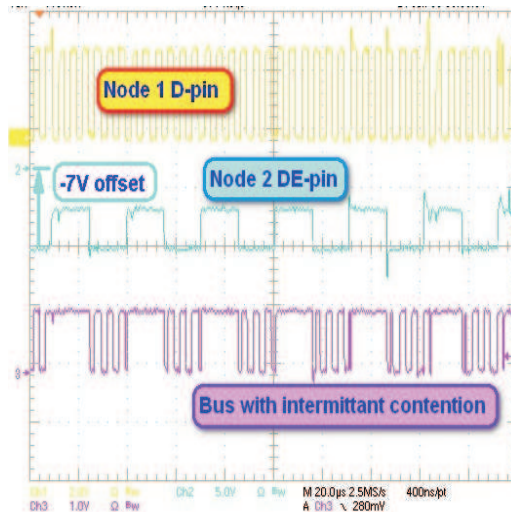

Figure 15. HVD3x Drivers Operate Correctly After Bus Contention Faults

**FUNCTION TABLES**
**Table 1. SN65HVD33, SN65HVD34, SN65HVD35  
DRIVER**

INPUTS		OUTPUTS	
D	DE	Y	Z
H	H	H	L
L	H	L	H
X	L or open	Z	Z
Open	H	L	H

**Table 2. SN65HVD33, SN65HVD34, SN65HVD35  
RECEIVER**

DIFFERENTIAL INPUTS $V_{ID} = V_{(A)} - V_{(B)}$	ENABLE $\overline{RE}$	OUTPUT R
$V_{ID} \leq -0.2\text{ V}$	L	L
$-0.2\text{ V} < V_{ID} < -0.02\text{ V}$	L	?
$-0.02\text{ V} \leq V_{ID}$	L	H
X	H or open	Z
Open Circuit	L	H
Idle circuit	L	H
Short Circuit, $V_{(A)} = V_{(B)}$	L	H

**Table 3. SN65HVD30, SN65HVD31, SN65HVD32  
DRIVER**

INPUT D	OUTPUTS	
	Y	Z
H	H	L
L	L	H
Open	L	H

**Table 4. SN65HVD30, SN65HVD31, SN65HVD32  
RECEIVER**

DIFFERENTIAL INPUTS $V_{ID} = V_{(A)} - V_{(B)}$	OUTPUT R
$V_{ID} \leq -0.2\text{ V}$	L
$-0.2\text{ V} < V_{ID} < -0.02\text{ V}$	?
$-0.02\text{ V} \leq V_{ID}$	H
Open Circuit	H
Idle circuit	H
Short Circuit, $V_{(A)} = V_{(B)}$	H



EQUIVALENT INPUT AND OUTPUT SCHEMATIC DIAGRAMS

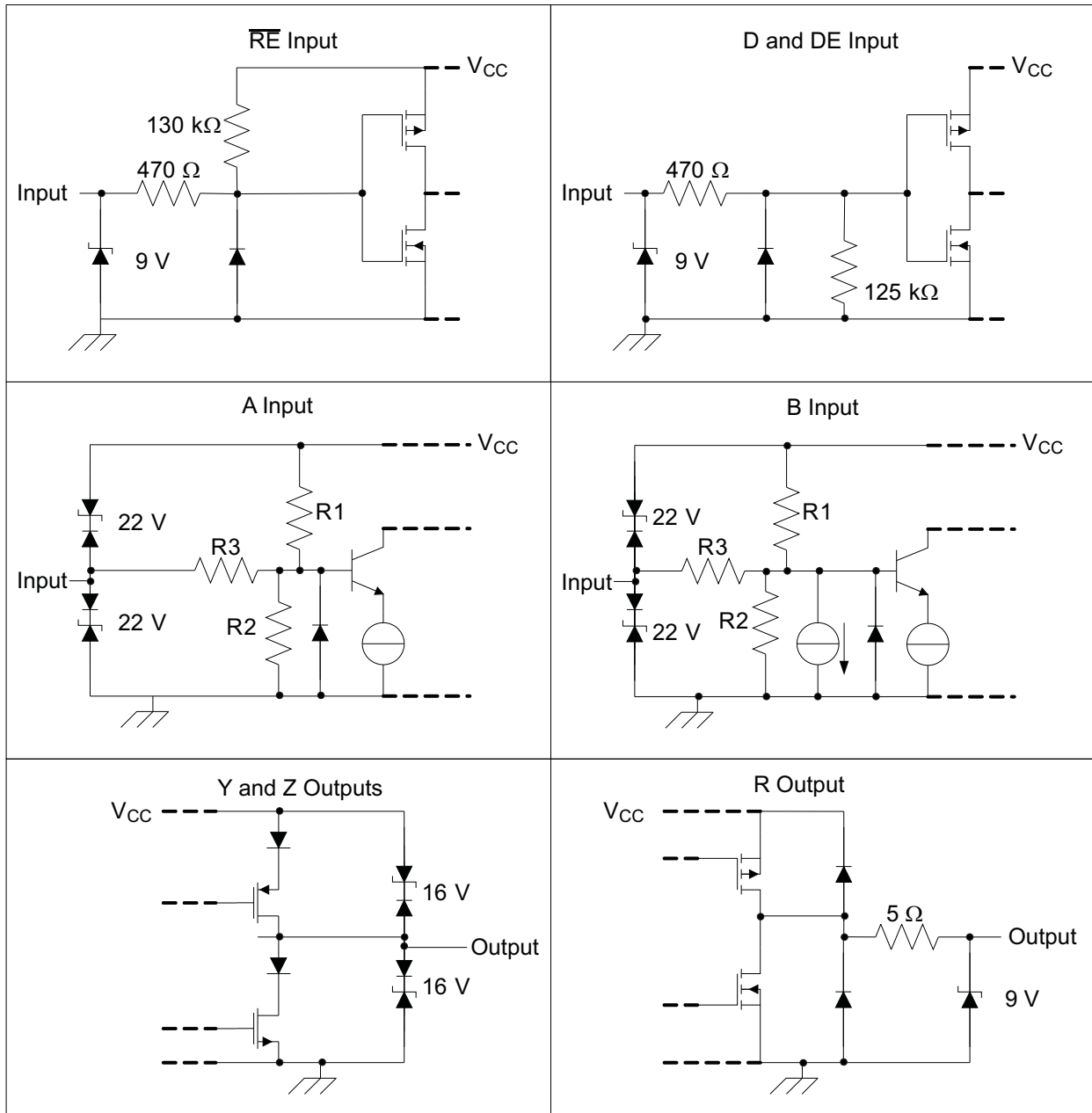

	R1/R2	R3
SN65HVD30, SN65HVD33	9 kΩ	45 kΩ
SN65HVD31, SN65HVD32, SN65HVD34, SN65HVD35	36 kΩ	180 kΩ

**TYPICAL CHARACTERISTICS**

**HVD30, HVD33  
RMS SUPPLY CURRENT  
vs  
SIGNALING RATE**

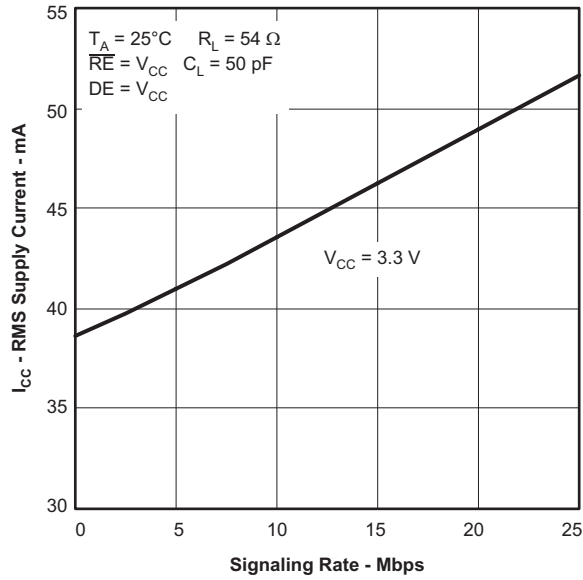

Figure 16.

**HVD31, HVD34  
RMS SUPPLY CURRENT  
vs  
SIGNALING RATE**

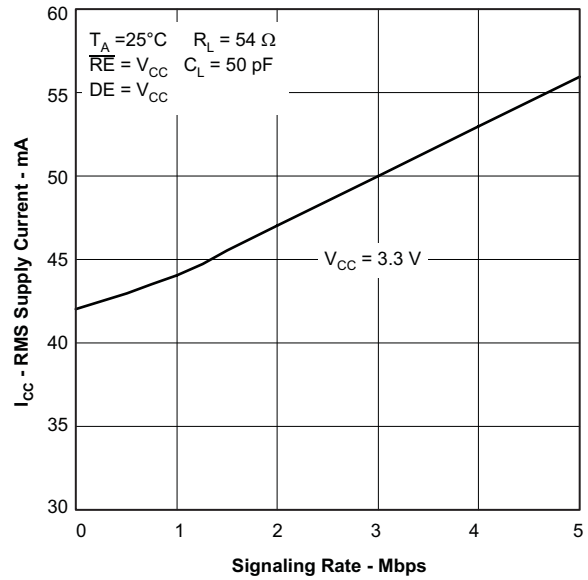

Figure 17.

**HVD32, HVD35  
RMS SUPPLY CURRENT  
vs  
SIGNALING RATE**

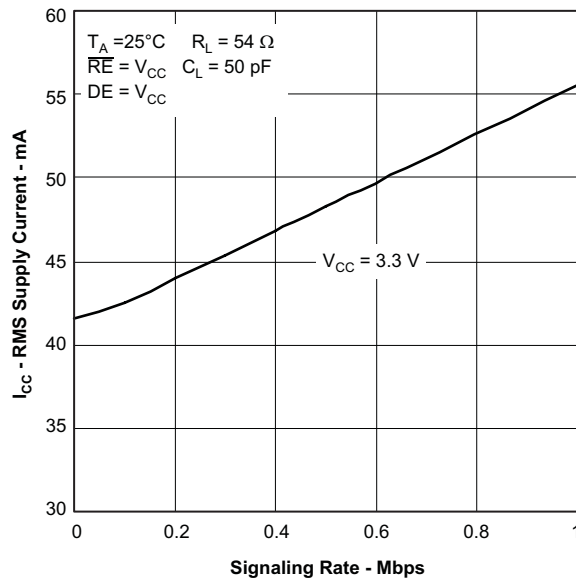

Figure 18.

TYPICAL CHARACTERISTICS (continued)

HVD30, HVD33  
BUS INPUT CURRENT  
vs  
INPUT VOLTAGE

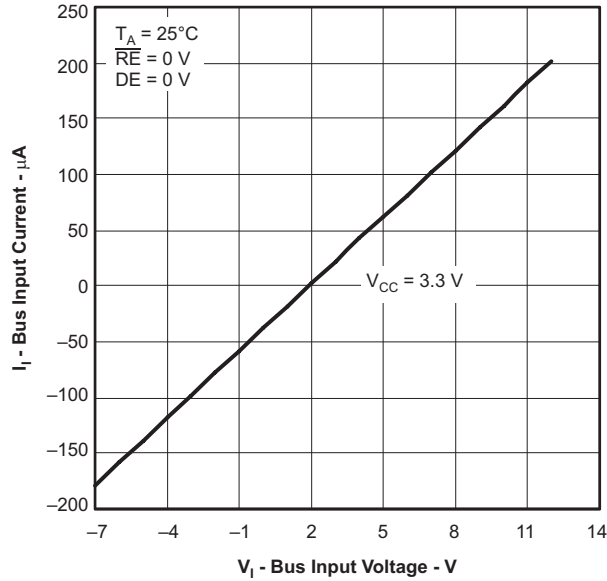

Figure 19.

HVD31, HVD32, HVD34, HVD35  
BUS INPUT CURRENT  
vs  
INPUT VOLTAGE

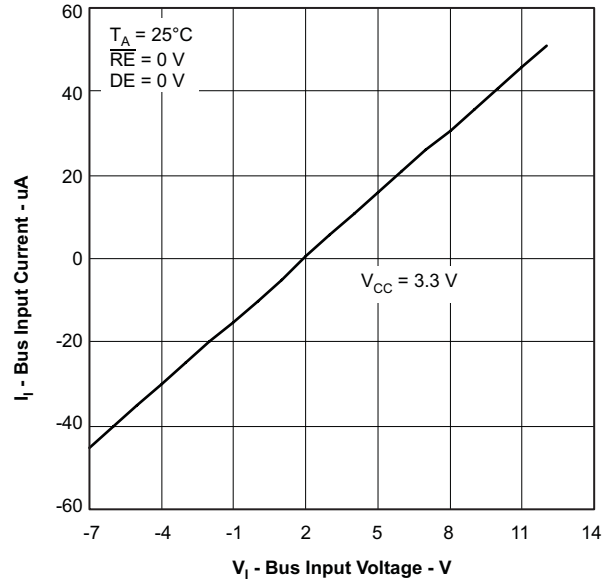

Figure 20.

DRIVER OUTPUT VOLTAGE  
vs  
DRIVER OUTPUT CURRENT

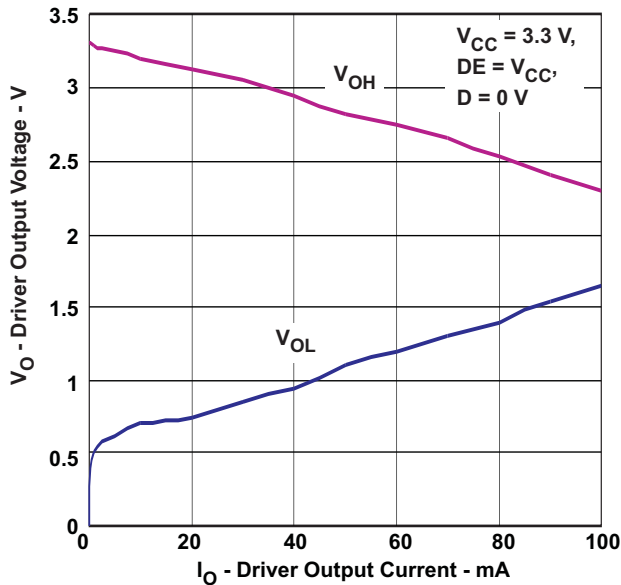

Figure 21.

DRIVER DIFFERENTIAL OUTPUT VOLTAGE  
vs  
DRIVER OUTPUT CURRENT

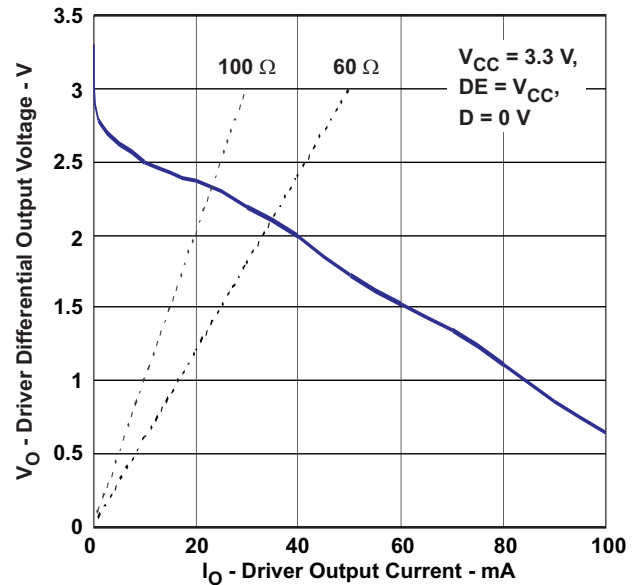
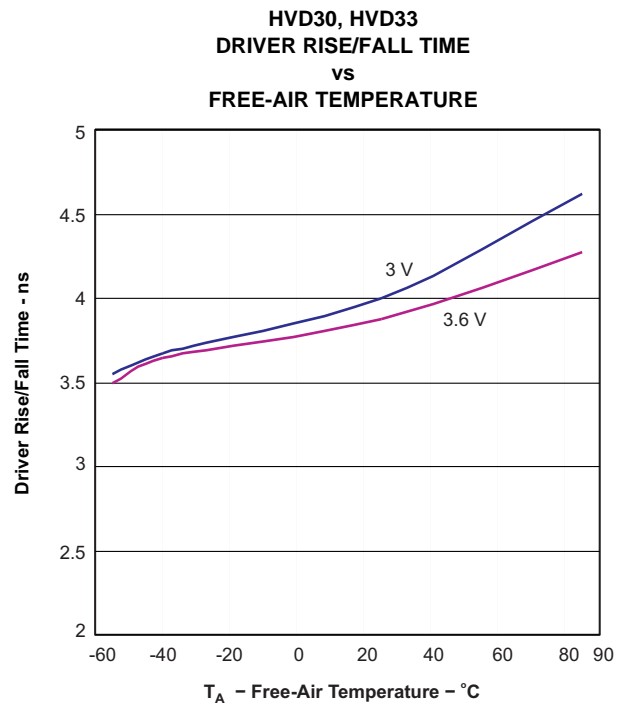
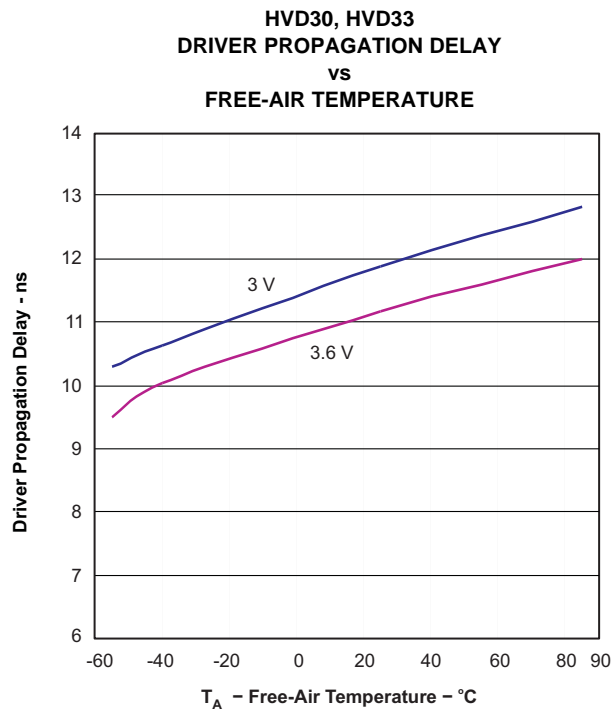
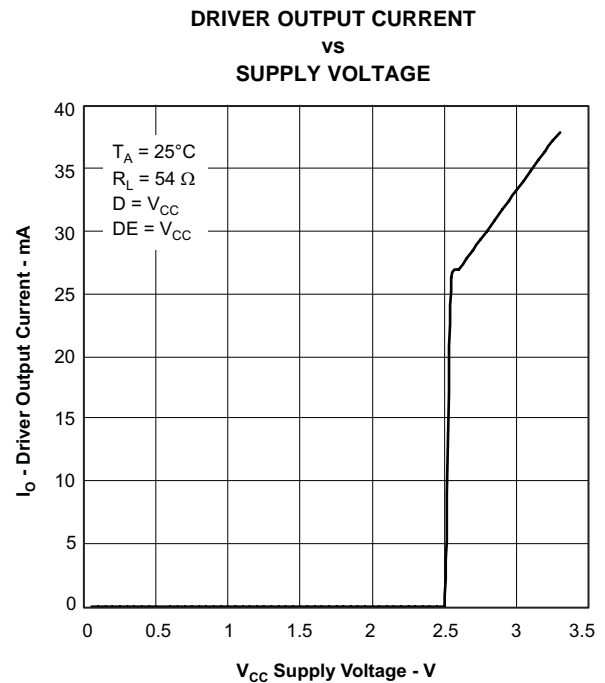
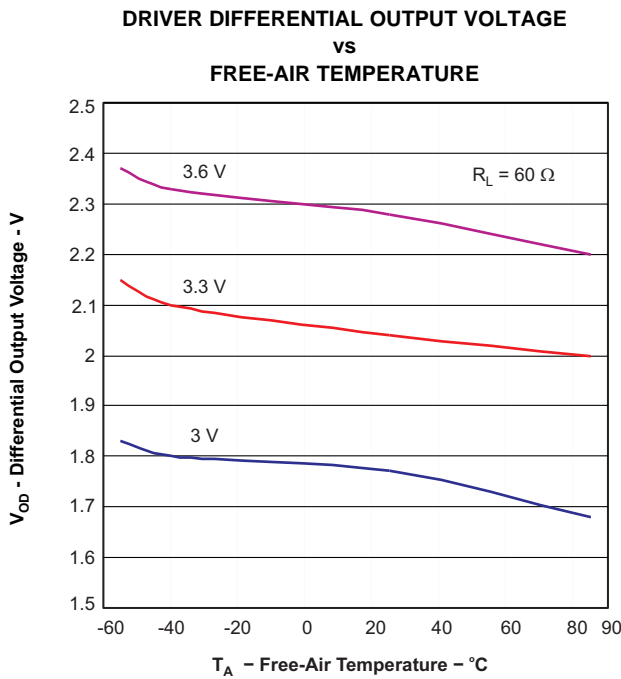

Figure 22.

**TYPICAL CHARACTERISTICS (continued)**

TYPICAL CHARACTERISTICS (continued)

RECEIVER THRESHOLD  
vs  
AMBIENT TEMPERATURE

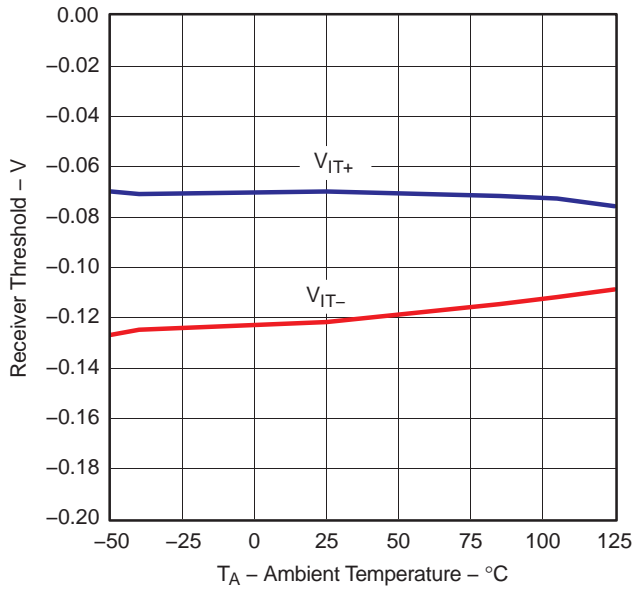

Figure 27.

RECEIVER THRESHOLD  
vs  
COMMON-MODE VOLTAGE

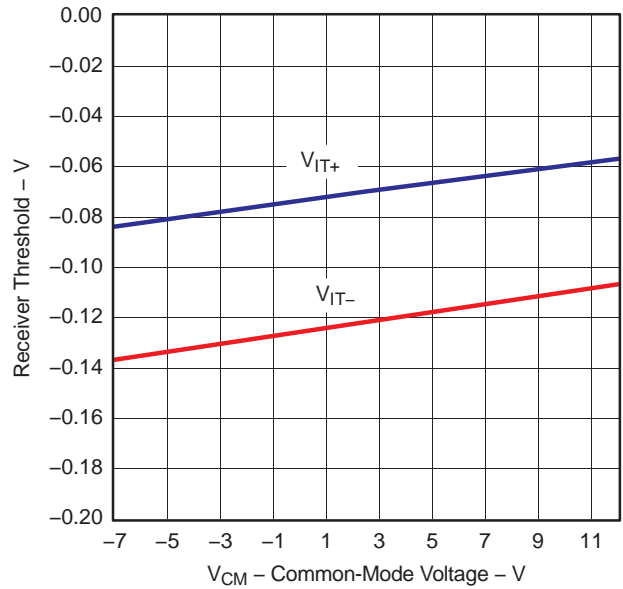

Figure 28.

SUPPLY CURRENT  
vs  
FREE-AIR TEMPERATURE

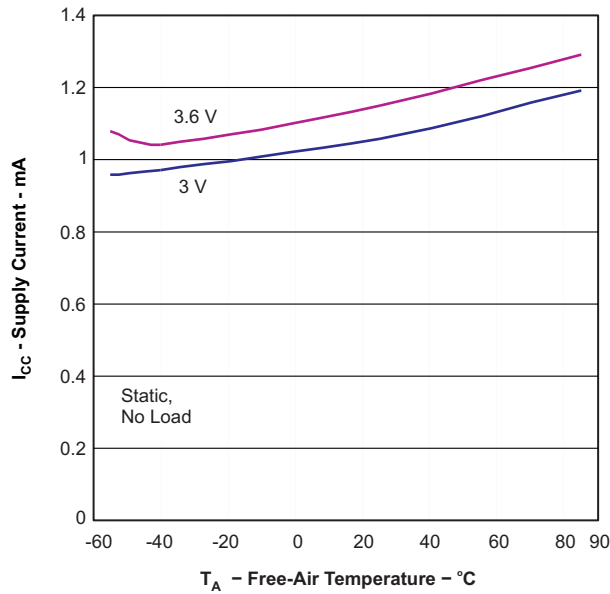

Figure 29.

ENABLE TIME  
vs  
COMMON-MODE VOLTAGE (SEE Figure 31)

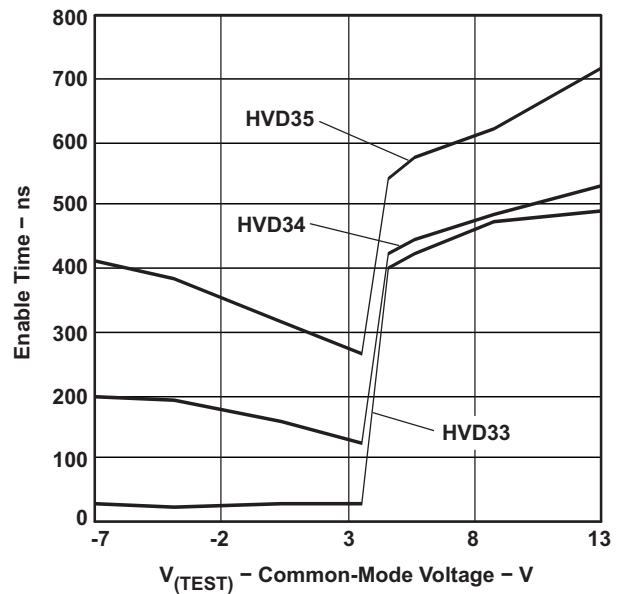

Figure 30.

TYPICAL CHARACTERISTICS (continued)

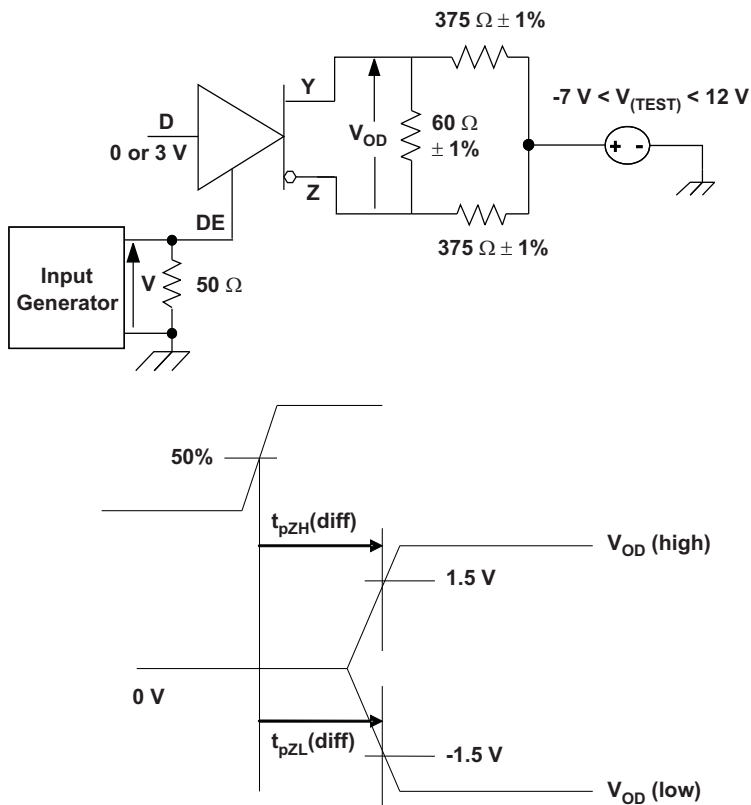

Figure 31. Driver Enable Time From DE to V<sub>OD</sub>

The time  $t_{pZL}(x)$  is the measure from DE to  $V_{OD}(x)$ .  $V_{OD}$  is valid when it is greater than 1.5 V.

**PACKAGING INFORMATION**

Orderable Device	Status (1)	Package Type	Package Drawing	Pins	Package Qty	Eco Plan (2)	Lead/Ball Finish	MSL Peak Temp (3)	Op Temp (°C)	Top-Side Markings (4)	Samples
SN65HVD30D	ACTIVE	SOIC	D	8	75	Green (RoHS & no Sb/Br)	CU NIPDAU	Level-1-260C-UNLIM	-40 to 85	VP30	<a href="#">Samples</a>
SN65HVD30DG4	ACTIVE	SOIC	D	8	75	Green (RoHS & no Sb/Br)	CU NIPDAU	Level-1-260C-UNLIM	-40 to 85	VP30	<a href="#">Samples</a>
SN65HVD30DR	ACTIVE	SOIC	D	8	2500	Green (RoHS & no Sb/Br)	CU NIPDAU	Level-1-260C-UNLIM	-40 to 85	VP30	<a href="#">Samples</a>
SN65HVD30DRG4	ACTIVE	SOIC	D	8	2500	Green (RoHS & no Sb/Br)	CU NIPDAU	Level-1-260C-UNLIM	-40 to 85	VP30	<a href="#">Samples</a>
SN65HVD31D	ACTIVE	SOIC	D	8	75	Green (RoHS & no Sb/Br)	CU NIPDAU	Level-1-260C-UNLIM		VP31	<a href="#">Samples</a>
SN65HVD31DG4	ACTIVE	SOIC	D	8	75	Green (RoHS & no Sb/Br)	CU NIPDAU	Level-1-260C-UNLIM		VP31	<a href="#">Samples</a>
SN65HVD31DR	ACTIVE	SOIC	D	8	2500	Green (RoHS & no Sb/Br)	CU NIPDAU	Level-1-260C-UNLIM		VP31	<a href="#">Samples</a>
SN65HVD31DRG4	ACTIVE	SOIC	D	8	2500	Green (RoHS & no Sb/Br)	CU NIPDAU	Level-1-260C-UNLIM		VP31	<a href="#">Samples</a>
SN65HVD32D	ACTIVE	SOIC	D	8	75	Green (RoHS & no Sb/Br)	CU NIPDAU	Level-1-260C-UNLIM		VP32	<a href="#">Samples</a>
SN65HVD32DG4	ACTIVE	SOIC	D	8	75	Green (RoHS & no Sb/Br)	CU NIPDAU	Level-1-260C-UNLIM		VP32	<a href="#">Samples</a>
SN65HVD32DR	ACTIVE	SOIC	D	8	2500	Green (RoHS & no Sb/Br)	CU NIPDAU	Level-1-260C-UNLIM		VP32	<a href="#">Samples</a>
SN65HVD32DRG4	ACTIVE	SOIC	D	8	2500	Green (RoHS & no Sb/Br)	CU NIPDAU	Level-1-260C-UNLIM		VP32	<a href="#">Samples</a>
SN65HVD33D	ACTIVE	SOIC	D	14	50	Green (RoHS & no Sb/Br)	CU NIPDAU	Level-1-260C-UNLIM	-40 to 85	65HVD33	<a href="#">Samples</a>
SN65HVD33DG4	ACTIVE	SOIC	D	14	50	Green (RoHS & no Sb/Br)	CU NIPDAU	Level-1-260C-UNLIM	-40 to 85	65HVD33	<a href="#">Samples</a>
SN65HVD33DR	ACTIVE	SOIC	D	14	2500	Green (RoHS & no Sb/Br)	CU NIPDAU	Level-1-260C-UNLIM	-40 to 85	65HVD33	<a href="#">Samples</a>
SN65HVD33DRG4	ACTIVE	SOIC	D	14	2500	Green (RoHS & no Sb/Br)	CU NIPDAU	Level-1-260C-UNLIM	-40 to 85	65HVD33	<a href="#">Samples</a>
SN65HVD33RHRLR	ACTIVE	QFN	RHL	20	3000	Green (RoHS & no Sb/Br)	CU NIPDAU	Level-2-260C-1 YEAR	-40 to 85	65HVD33	<a href="#">Samples</a>

Orderable Device	Status (1)	Package Type	Package Drawing	Pins	Package Qty	Eco Plan (2)	Lead/Ball Finish	MSL Peak Temp (3)	Op Temp (°C)	Top-Side Markings (4)	Samples
SN65HVD33RHLT	ACTIVE	QFN	RHL	20	250	Green (RoHS & no Sb/Br)	CU NIPDAU	Level-2-260C-1 YEAR	-40 to 85	65HVD33	<a href="#">Samples</a>
SN65HVD34D	ACTIVE	SOIC	D	14	50	Green (RoHS & no Sb/Br)	CU NIPDAU	Level-1-260C-UNLIM	-40 to 85	65HVD34	<a href="#">Samples</a>
SN65HVD34DG4	ACTIVE	SOIC	D	14	50	Green (RoHS & no Sb/Br)	CU NIPDAU	Level-1-260C-UNLIM	-40 to 85	65HVD34	<a href="#">Samples</a>
SN65HVD34DR	ACTIVE	SOIC	D	14	2500	Green (RoHS & no Sb/Br)	CU NIPDAU	Level-1-260C-UNLIM	-40 to 85	65HVD34	<a href="#">Samples</a>
SN65HVD34DRG4	ACTIVE	SOIC	D	14	2500	Green (RoHS & no Sb/Br)	CU NIPDAU	Level-1-260C-UNLIM	-40 to 85	65HVD34	<a href="#">Samples</a>
SN65HVD35D	ACTIVE	SOIC	D	14	50	Green (RoHS & no Sb/Br)	CU NIPDAU	Level-1-260C-UNLIM	-40 to 85	65HVD35	<a href="#">Samples</a>
SN65HVD35DG4	ACTIVE	SOIC	D	14	50	Green (RoHS & no Sb/Br)	CU NIPDAU	Level-1-260C-UNLIM	-40 to 85	65HVD35	<a href="#">Samples</a>
SN65HVD35DR	ACTIVE	SOIC	D	14	2500	Green (RoHS & no Sb/Br)	CU NIPDAU	Level-1-260C-UNLIM	-40 to 85	65HVD35	<a href="#">Samples</a>
SN65HVD35DRG4	ACTIVE	SOIC	D	14	2500	Green (RoHS & no Sb/Br)	CU NIPDAU	Level-1-260C-UNLIM	-40 to 85	65HVD35	<a href="#">Samples</a>

(1) The marketing status values are defined as follows:

**ACTIVE:** Product device recommended for new designs.

**LIFEBUY:** TI has announced that the device will be discontinued, and a lifetime-buy period is in effect.

**NRND:** Not recommended for new designs. Device is in production to support existing customers, but TI does not recommend using this part in a new design.

**PREVIEW:** Device has been announced but is not in production. Samples may or may not be available.

**OBsolete:** TI has discontinued the production of the device.

(2) Eco Plan - The planned eco-friendly classification: Pb-Free (RoHS), Pb-Free (RoHS Exempt), or Green (RoHS & no Sb/Br) - please check <http://www.ti.com/productcontent> for the latest availability information and additional product content details.

**TBD:** The Pb-Free/Green conversion plan has not been defined.

**Pb-Free (RoHS):** TI's terms "Lead-Free" or "Pb-Free" mean semiconductor products that are compatible with the current RoHS requirements for all 6 substances, including the requirement that lead not exceed 0.1% by weight in homogeneous materials. Where designed to be soldered at high temperatures, TI Pb-Free products are suitable for use in specified lead-free processes.

**Pb-Free (RoHS Exempt):** This component has a RoHS exemption for either 1) lead-based flip-chip solder bumps used between the die and package, or 2) lead-based die adhesive used between the die and leadframe. The component is otherwise considered Pb-Free (RoHS compatible) as defined above.

**Green (RoHS & no Sb/Br):** TI defines "Green" to mean Pb-Free (RoHS compatible), and free of Bromine (Br) and Antimony (Sb) based flame retardants (Br or Sb do not exceed 0.1% by weight in homogeneous material)

(3) MSL, Peak Temp. -- The Moisture Sensitivity Level rating according to the JEDEC industry standard classifications, and peak solder temperature.



<sup>(4)</sup> Only one of markings shown within the brackets will appear on the physical device.

**Important Information and Disclaimer:** The information provided on this page represents TI's knowledge and belief as of the date that it is provided. TI bases its knowledge and belief on information provided by third parties, and makes no representation or warranty as to the accuracy of such information. Efforts are underway to better integrate information from third parties. TI has taken and continues to take reasonable steps to provide representative and accurate information but may not have conducted destructive testing or chemical analysis on incoming materials and chemicals. TI and TI suppliers consider certain information to be proprietary, and thus CAS numbers and other limited information may not be available for release.

In no event shall TI's liability arising out of such information exceed the total purchase price of the TI part(s) at issue in this document sold by TI to Customer on an annual basis.

**OTHER QUALIFIED VERSIONS OF SN65HVD30, SN65HVD33 :**

- Enhanced Product: [SN65HVD30-EP](#), [SN65HVD33-EP](#)

NOTE: Qualified Version Definitions:

- Enhanced Product - Supports Defense, Aerospace and Medical Applications

**TAPE AND REEL INFORMATION**

**QUADRANT ASSIGNMENTS FOR PIN 1 ORIENTATION IN TAPE**

\*All dimensions are nominal

Device	Package Type	Package Drawing	Pins	SPQ	Reel Diameter (mm)	Reel Width W1 (mm)	A0 (mm)	B0 (mm)	K0 (mm)	P1 (mm)	W (mm)	Pin1 Quadrant
SN65HVD30DR	SOIC	D	8	2500	330.0	12.4	6.4	5.2	2.1	8.0	12.0	Q1
SN65HVD31DR	SOIC	D	8	2500	330.0	12.4	6.4	5.2	2.1	8.0	12.0	Q1
SN65HVD32DR	SOIC	D	8	2500	330.0	12.4	6.4	5.2	2.1	8.0	12.0	Q1
SN65HVD33RHLR	QFN	RHL	20	3000	330.0	12.4	3.8	4.8	1.6	8.0	12.0	Q1
SN65HVD33RHLL	QFN	RHL	20	250	180.0	12.4	3.8	4.8	1.6	8.0	12.0	Q1
SN65HVD34DR	SOIC	D	14	2500	330.0	16.4	6.5	9.0	2.1	8.0	16.0	Q1
SN65HVD35DR	SOIC	D	14	2500	330.0	16.4	6.5	9.0	2.1	8.0	16.0	Q1

**TAPE AND REEL BOX DIMENSIONS**

\*All dimensions are nominal

Device	Package Type	Package Drawing	Pins	SPQ	Length (mm)	Width (mm)	Height (mm)
SN65HVD30DR	SOIC	D	8	2500	367.0	367.0	35.0
SN65HVD31DR	SOIC	D	8	2500	367.0	367.0	35.0
SN65HVD32DR	SOIC	D	8	2500	367.0	367.0	35.0
SN65HVD33RHRLR	QFN	RHL	20	3000	367.0	367.0	35.0
SN65HVD33RHRLT	QFN	RHL	20	250	210.0	185.0	35.0
SN65HVD34DR	SOIC	D	14	2500	367.0	367.0	38.0
SN65HVD35DR	SOIC	D	14	2500	367.0	367.0	38.0

D (R-PDSO-G14)

PLASTIC SMALL OUTLINE



- NOTES:
- A. All linear dimensions are in inches (millimeters).
  - B. This drawing is subject to change without notice.
  -  Body length does not include mold flash, protrusions, or gate burrs. Mold flash, protrusions, or gate burrs shall not exceed 0.006 (0,15) each side.
  -  Body width does not include interlead flash. Interlead flash shall not exceed 0.017 (0,43) each side.
  - E. Reference JEDEC MS-012 variation AB.

D (R-PDSO-G14)

PLASTIC SMALL OUTLINE



- NOTES:
- All linear dimensions are in millimeters.
  - This drawing is subject to change without notice.
  - Publication IPC-7351 is recommended for alternate designs.
  - Laser cutting apertures with trapezoidal walls and also rounding corners will offer better paste release. Customers should contact their board assembly site for stencil design recommendations. Refer to IPC-7525 for other stencil recommendations.
  - Customers should contact their board fabrication site for solder mask tolerances between and around signal pads.

# MECHANICAL DATA

RHL (R-PVQFN-N20)

PLASTIC QUAD FLATPACK NO-LEAD

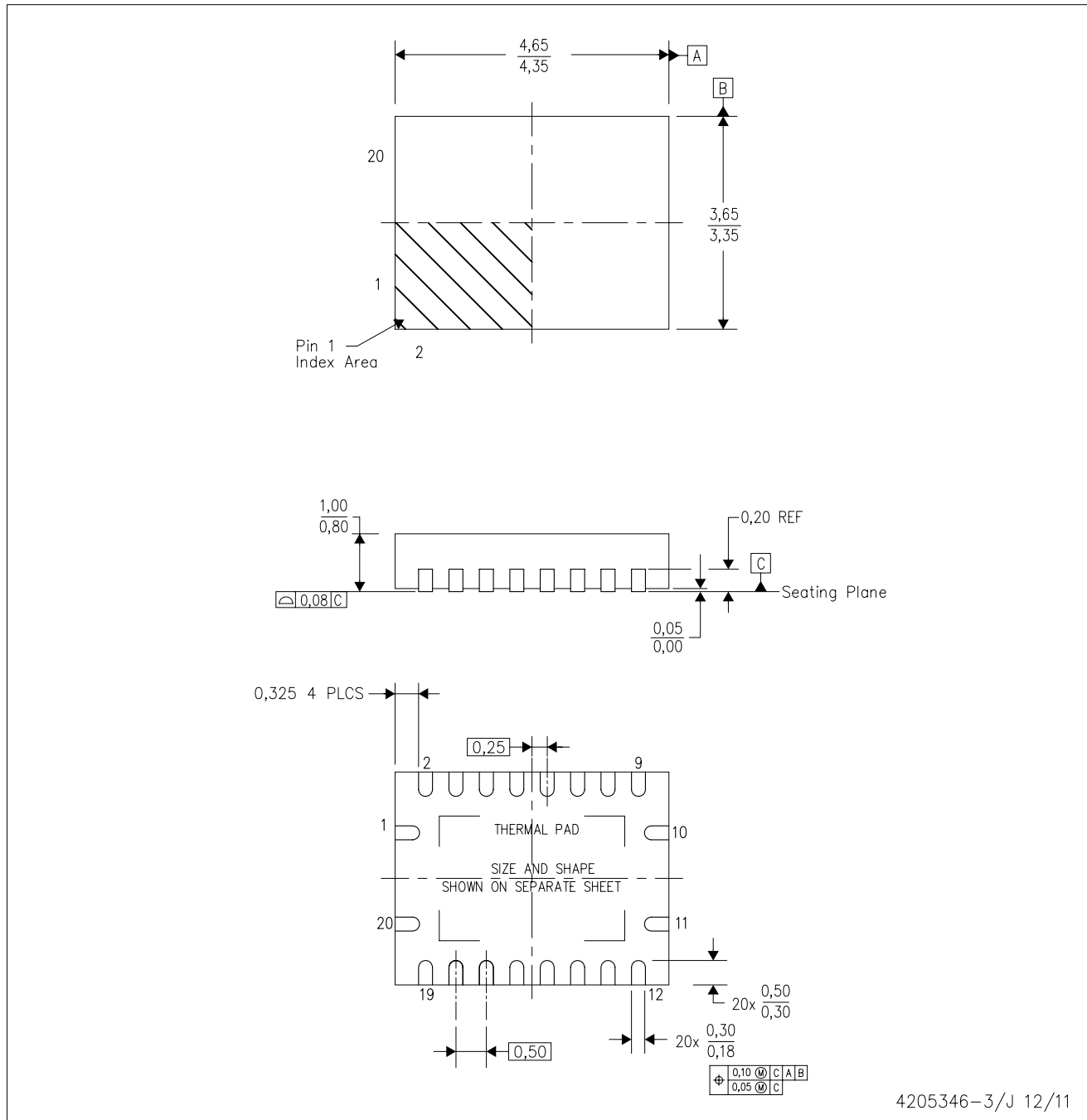

4205346-3/J 12/11

- NOTES:
- All linear dimensions are in millimeters. Dimensioning and tolerancing per ASME Y14.5M-1994.
  - This drawing is subject to change without notice.
  - QFN (Quad Flatpack No-Lead) Package configuration.
  - The package thermal pad must be soldered to the board for thermal and mechanical performance.
  - See the additional figure in the Product Data Sheet for details regarding the exposed thermal pad features and dimensions.

## THERMAL PAD MECHANICAL DATA

RHL (S-PVQFN-N20)

PLASTIC QUAD FLATPACK NO-LEAD

### THERMAL INFORMATION

This package incorporates an exposed thermal pad that is designed to be attached directly to an external heatsink. The thermal pad must be soldered directly to the printed circuit board (PCB). After soldering, the PCB can be used as a heatsink. In addition, through the use of thermal vias, the thermal pad can be attached directly to the appropriate copper plane shown in the electrical schematic for the device, or alternatively, can be attached to a special heatsink structure designed into the PCB. This design optimizes the heat transfer from the integrated circuit (IC).

For information on the Quad Flatpack No-Lead (QFN) package and its advantages, refer to Application Report, QFN/SON PCB Attachment, Texas Instruments Literature No. SLUA271. This document is available at [www.ti.com](http://www.ti.com).

The exposed thermal pad dimensions for this package are shown in the following illustration.

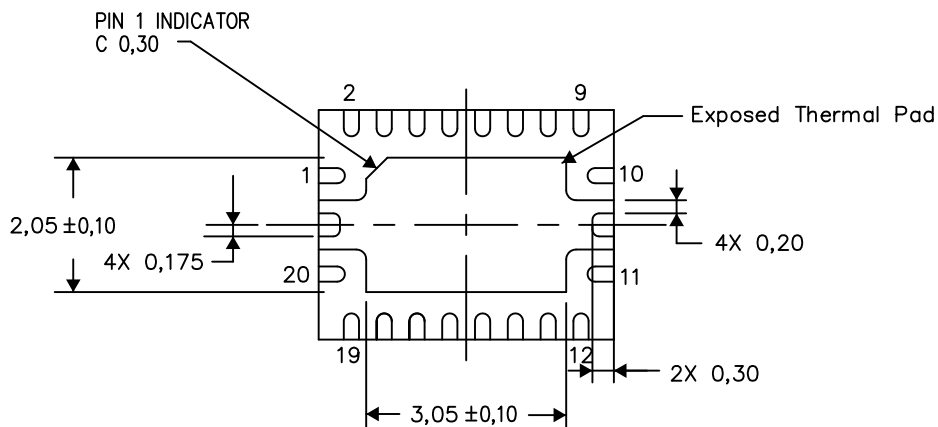

Bottom View

Exposed Thermal Pad Dimensions

4206363-3/M 08/12

NOTE: All linear dimensions are in millimeters

RHL (R-PVQFN-N20)

PLASTIC QUAD FLATPACK NO-LEAD

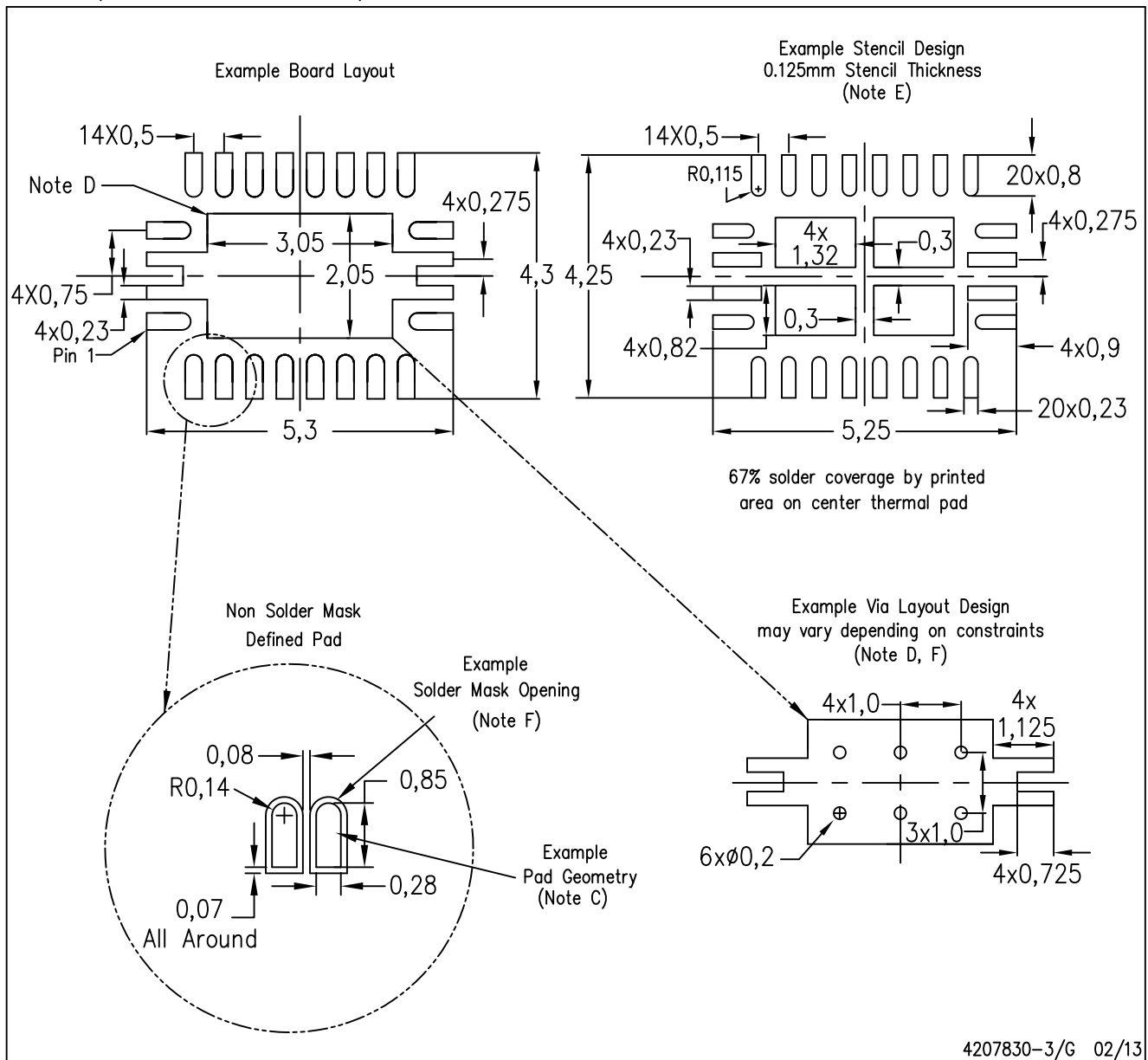



- NOTES:
- All linear dimensions are in millimeters.
  - This drawing is subject to change without notice.
  - Publication IPC-7351 is recommended for alternate designs.
  - This package is designed to be soldered to a thermal pad on the board. Refer to Application Note, Quad Flat-Pack Packages, Texas Instruments Literature No. SLUA271, and also the Product Data Sheets for specific thermal information, via requirements, and recommended board layout. These documents are available at [www.ti.com](http://www.ti.com) <<http://www.ti.com>>.
  - Laser cutting apertures with trapezoidal walls and also rounding corners will offer better paste release. Customers should contact their board assembly site for stencil design recommendations. Refer to IPC 7525 for stencil design considerations.
  - Customers should contact their board fabrication site for minimum solder mask web tolerances between signal pads.



D (R-PDSO-G8)

PLASTIC SMALL OUTLINE



- NOTES:
- A. All linear dimensions are in inches (millimeters).
  - B. This drawing is subject to change without notice.
  -  Body length does not include mold flash, protrusions, or gate burrs. Mold flash, protrusions, or gate burrs shall not exceed 0.006 (0,15) each side.
  -  Body width does not include interlead flash. Interlead flash shall not exceed 0.017 (0,43) each side.
  - E. Reference JEDEC MS-012 variation AA.

D (R-PDSO-G8)

PLASTIC SMALL OUTLINE



- NOTES:
- A. All linear dimensions are in millimeters.
  - B. This drawing is subject to change without notice.
  - C. Publication IPC-7351 is recommended for alternate designs.
  - D. Laser cutting apertures with trapezoidal walls and also rounding corners will offer better paste release. Customers should contact their board assembly site for stencil design recommendations. Refer to IPC-7525 for other stencil recommendations.
  - E. Customers should contact their board fabrication site for solder mask tolerances between and around signal pads.

## IMPORTANT NOTICE

Texas Instruments Incorporated and its subsidiaries (TI) reserve the right to make corrections, enhancements, improvements and other changes to its semiconductor products and services per JESD46, latest issue, and to discontinue any product or service per JESD48, latest issue. Buyers should obtain the latest relevant information before placing orders and should verify that such information is current and complete. All semiconductor products (also referred to herein as "components") are sold subject to TI's terms and conditions of sale supplied at the time of order acknowledgment.

TI warrants performance of its components to the specifications applicable at the time of sale, in accordance with the warranty in TI's terms and conditions of sale of semiconductor products. Testing and other quality control techniques are used to the extent TI deems necessary to support this warranty. Except where mandated by applicable law, testing of all parameters of each component is not necessarily performed.

TI assumes no liability for applications assistance or the design of Buyers' products. Buyers are responsible for their products and applications using TI components. To minimize the risks associated with Buyers' products and applications, Buyers should provide adequate design and operating safeguards.

TI does not warrant or represent that any license, either express or implied, is granted under any patent right, copyright, mask work right, or other intellectual property right relating to any combination, machine, or process in which TI components or services are used. Information published by TI regarding third-party products or services does not constitute a license to use such products or services or a warranty or endorsement thereof. Use of such information may require a license from a third party under the patents or other intellectual property of the third party, or a license from TI under the patents or other intellectual property of TI.

Reproduction of significant portions of TI information in TI data books or data sheets is permissible only if reproduction is without alteration and is accompanied by all associated warranties, conditions, limitations, and notices. TI is not responsible or liable for such altered documentation. Information of third parties may be subject to additional restrictions.

Resale of TI components or services with statements different from or beyond the parameters stated by TI for that component or service voids all express and any implied warranties for the associated TI component or service and is an unfair and deceptive business practice. TI is not responsible or liable for any such statements.

Buyer acknowledges and agrees that it is solely responsible for compliance with all legal, regulatory and safety-related requirements concerning its products, and any use of TI components in its applications, notwithstanding any applications-related information or support that may be provided by TI. Buyer represents and agrees that it has all the necessary expertise to create and implement safeguards which anticipate dangerous consequences of failures, monitor failures and their consequences, lessen the likelihood of failures that might cause harm and take appropriate remedial actions. Buyer will fully indemnify TI and its representatives against any damages arising out of the use of any TI components in safety-critical applications.

In some cases, TI components may be promoted specifically to facilitate safety-related applications. With such components, TI's goal is to help enable customers to design and create their own end-product solutions that meet applicable functional safety standards and requirements. Nonetheless, such components are subject to these terms.

No TI components are authorized for use in FDA Class III (or similar life-critical medical equipment) unless authorized officers of the parties have executed a special agreement specifically governing such use.

Only those TI components which TI has specifically designated as military grade or "enhanced plastic" are designed and intended for use in military/aerospace applications or environments. Buyer acknowledges and agrees that any military or aerospace use of TI components which have **not** been so designated is solely at the Buyer's risk, and that Buyer is solely responsible for compliance with all legal and regulatory requirements in connection with such use.

TI has specifically designated certain components as meeting ISO/TS16949 requirements, mainly for automotive use. In any case of use of non-designated products, TI will not be responsible for any failure to meet ISO/TS16949.

### Products

Audio	<a href="http://www.ti.com/audio">www.ti.com/audio</a>
Amplifiers	<a href="http://amplifier.ti.com">amplifier.ti.com</a>
Data Converters	<a href="http://dataconverter.ti.com">dataconverter.ti.com</a>
DLP® Products	<a href="http://www.dlp.com">www.dlp.com</a>
DSP	<a href="http://dsp.ti.com">dsp.ti.com</a>
Clocks and Timers	<a href="http://www.ti.com/clocks">www.ti.com/clocks</a>
Interface	<a href="http://interface.ti.com">interface.ti.com</a>
Logic	<a href="http://logic.ti.com">logic.ti.com</a>
Power Mgmt	<a href="http://power.ti.com">power.ti.com</a>
Microcontrollers	<a href="http://microcontroller.ti.com">microcontroller.ti.com</a>
RFID	<a href="http://www.ti-rfid.com">www.ti-rfid.com</a>
OMAP Applications Processors	<a href="http://www.ti.com/omap">www.ti.com/omap</a>
Wireless Connectivity	<a href="http://www.ti.com/wirelessconnectivity">www.ti.com/wirelessconnectivity</a>

### Applications

Automotive and Transportation	<a href="http://www.ti.com/automotive">www.ti.com/automotive</a>
Communications and Telecom	<a href="http://www.ti.com/communications">www.ti.com/communications</a>
Computers and Peripherals	<a href="http://www.ti.com/computers">www.ti.com/computers</a>
Consumer Electronics	<a href="http://www.ti.com/consumer-apps">www.ti.com/consumer-apps</a>
Energy and Lighting	<a href="http://www.ti.com/energy">www.ti.com/energy</a>
Industrial	<a href="http://www.ti.com/industrial">www.ti.com/industrial</a>
Medical	<a href="http://www.ti.com/medical">www.ti.com/medical</a>
Security	<a href="http://www.ti.com/security">www.ti.com/security</a>
Space, Avionics and Defense	<a href="http://www.ti.com/space-avionics-defense">www.ti.com/space-avionics-defense</a>
Video and Imaging	<a href="http://www.ti.com/video">www.ti.com/video</a>

### TI E2E Community

[e2e.ti.com](http://e2e.ti.com)