

25-W DIGITAL AUDIO POWER AMPLIFIER WITH EQ AND DRC

Check for Samples: [TAS5713](#)

FEATURES

- **Audio Input/Output**
 - 25-W Into an 8- Ω Load From a 20-V Supply
 - Wide PVDD Range, From 8 V to 26 V
 - Supports BTL Configuration With 4- Ω Load
 - Efficient Class-D Operation Eliminates Need for Heatsinks
 - One Serial Audio Input (Two Audio Channels)
 - I²C Address Selection Pin (Chip Select)
 - Single Output Filter PBTL Support
 - Supports 8-kHz to 48-kHz Sample Rate (LJ/RJ/I²S)
- **Audio/PWM Processing**
 - Independent Channel Volume Controls With Gain of 24 dB to Mute
 - Programmable Two-Band Dynamic-Range Control
 - 22 Programmable Biquads for Speaker EQ and Other Audio-Processing Features
 - Programmable Coefficients for DRC Filters
 - DC Blocking Filters
- **General Features**
 - I²C Serial Control Interface Operational Without MCLK
 - Requires Only 3.3 V and PVDD
 - No External Oscillator: Internal Oscillator for Automatic Rate Detection
 - Surface-Mount, 48-Pin, 7-mm \times 7-mm HTQFP Package
 - Thermal and Short-Circuit Protection
 - 106-dB SNR, A-Weighted
- AD and BD PWM-Mode Support
- Up to 90% Efficient
- **Benefits**
 - EQ: Speaker Equalization Improves Audio Performance
 - DRC: Dynamic Range Compression. Can Be Used As Power Limiter. Enables Speaker Protection, Easy Listening, Night-Mode Listening
 - Autobank Switching: Preload Coefficients for Different Sample Rates. No Need to Write New Coefficients to the Part When Sample Rate Changes
 - Autodetect: Automatically Detects Sample-Rate Changes. No Need for External Microprocessor Intervention

DESCRIPTION

The TAS5713 is a 25-W, efficient, digital-audio power amplifier for driving stereo bridge-tied speakers. One serial data input allows processing of up to two discrete audio channels and seamless integration to most digital audio processors and MPEG decoders. The device accepts a wide range of input data and data rates. A fully programmable data path routes these channels to the internal speaker drivers.

The TAS5713 is a slave-only device receiving all clocks from external sources. The TAS5713 operates with a PWM carrier between a 384-kHz switching rate and a 352-KHz switching rate, depending on the input sample rate. Oversampling combined with a fourth-order noise shaper provides a flat noise floor and excellent dynamic range from 20 Hz to 20 kHz..



Please be aware that an important notice concerning availability, standard warranty, and use in critical applications of Texas Instruments semiconductor products and disclaimers thereto appears at the end of this data sheet.



These devices have limited built-in ESD protection. The leads should be shorted together or the device placed in conductive foam during storage or handling to prevent electrostatic damage to the MOS gates.

SIMPLIFIED APPLICATION DIAGRAM

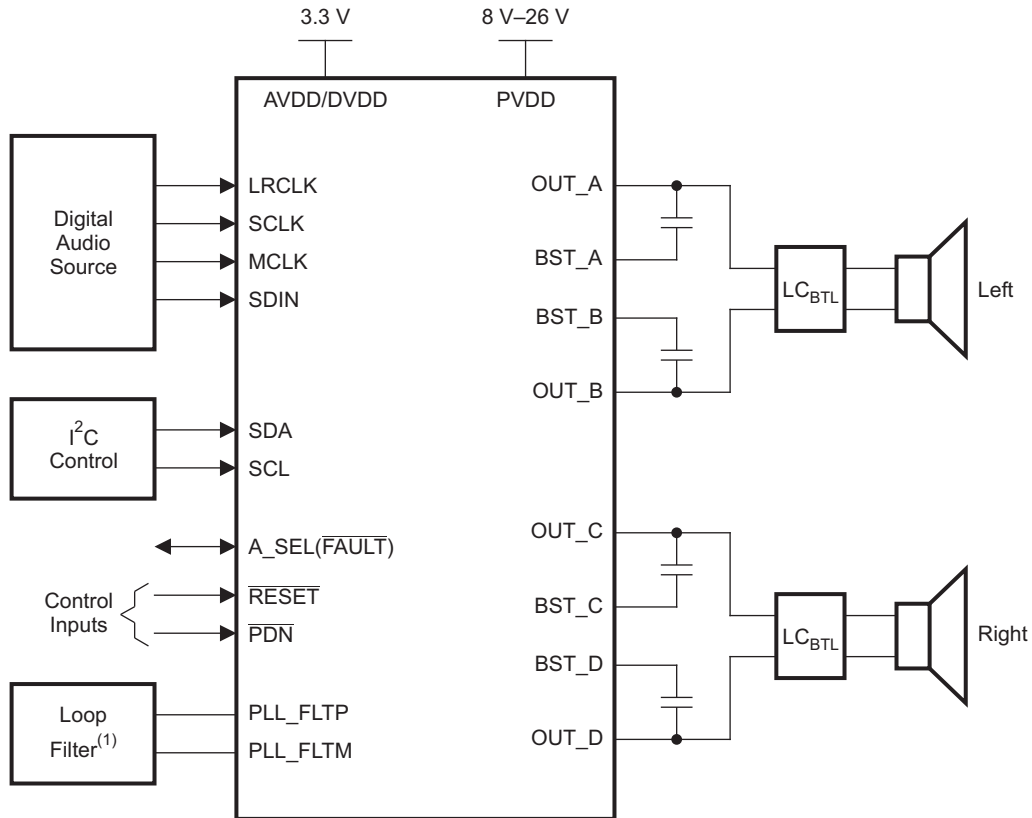

B0264-10

(1) See the TAS5713 User's Guide for loop filter values

FUNCTIONAL VIEW

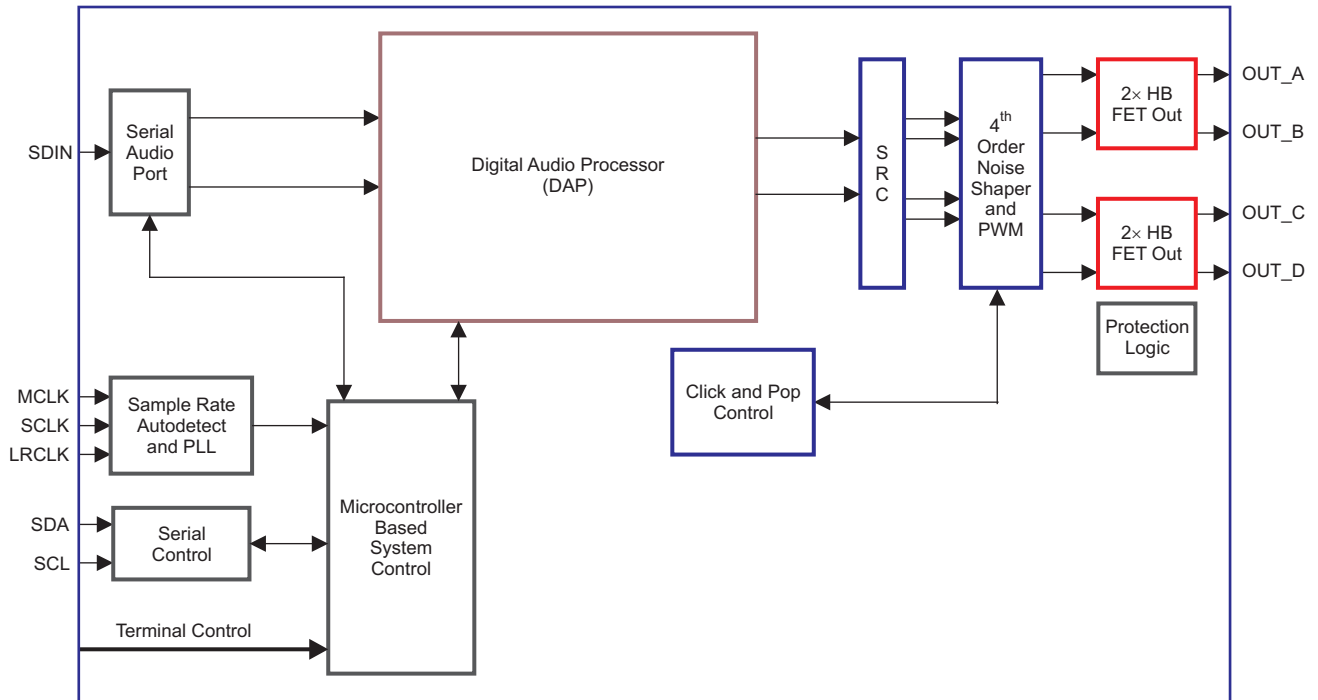

B0262-06

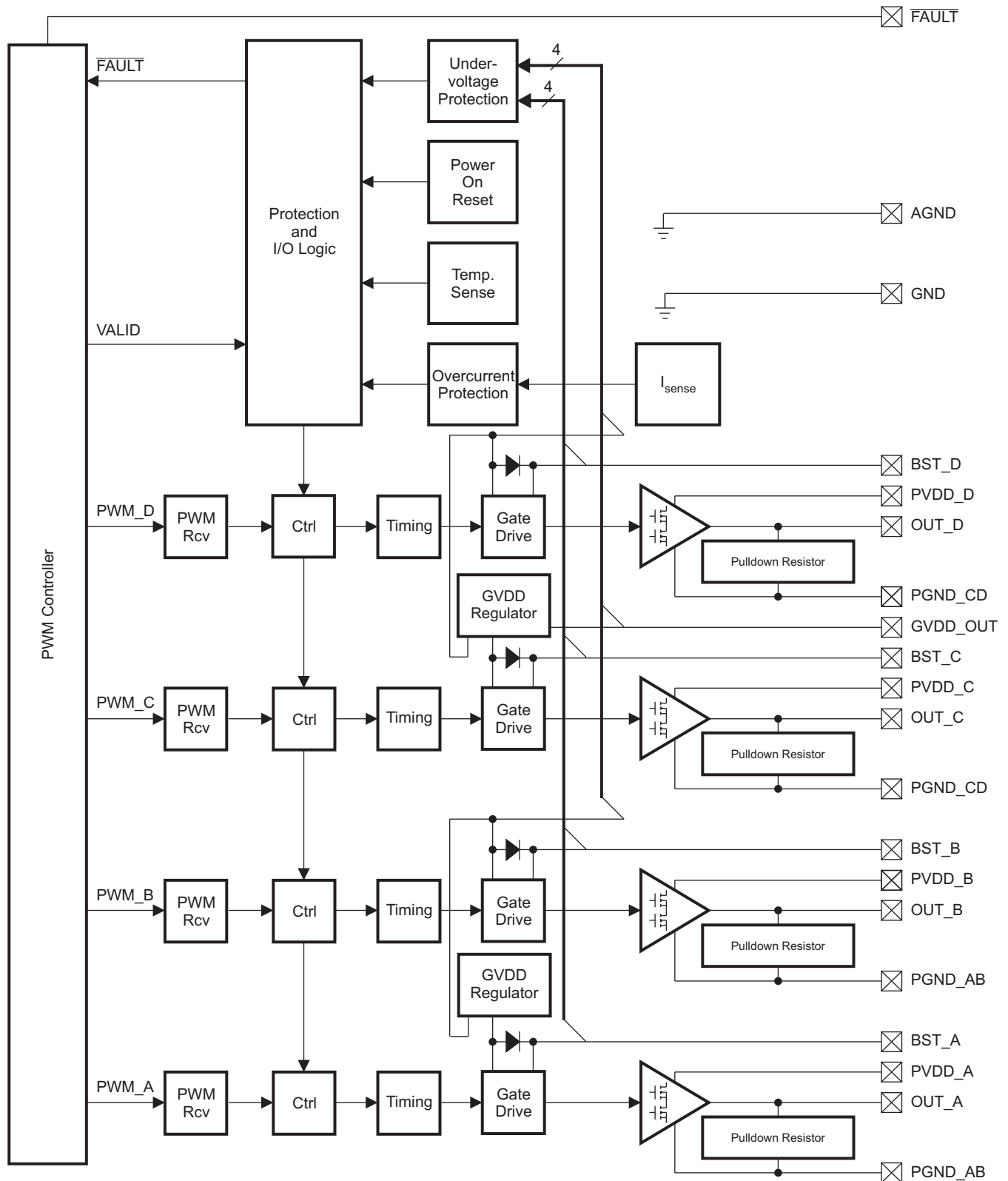

B0034-06

Figure 1. Power-Stage Functional Block Diagram

DAP Process Structure

I²C Subaddress in Red

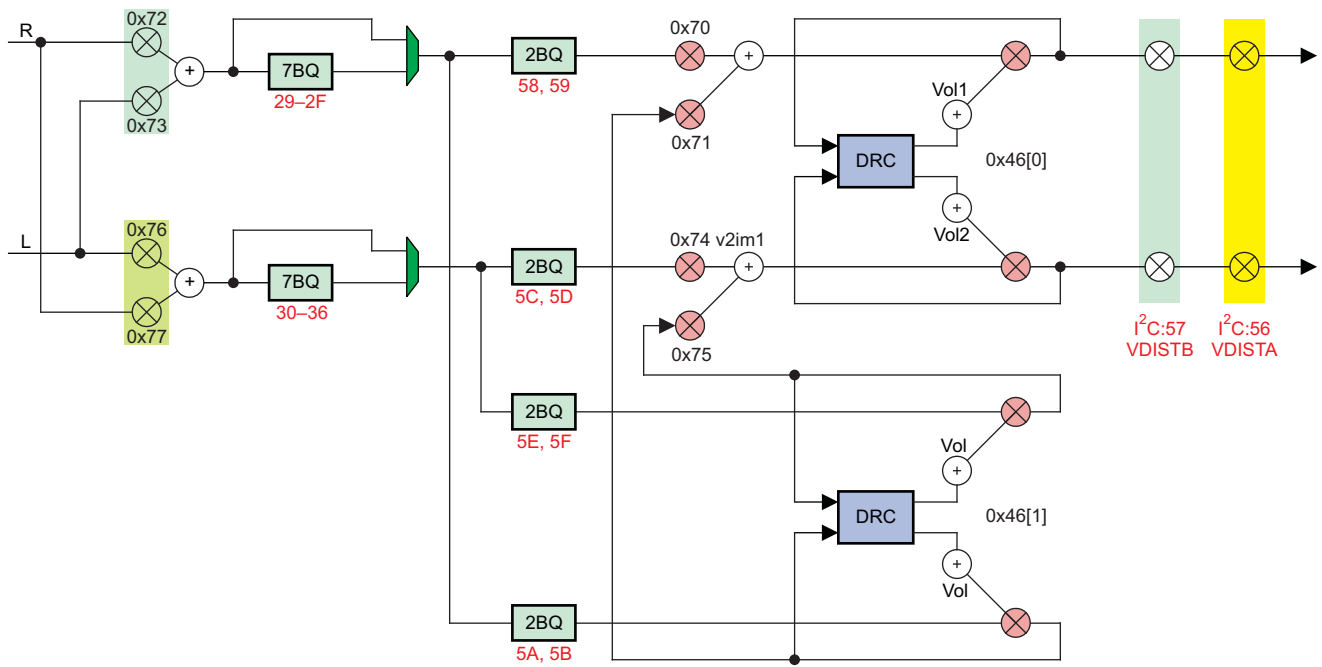

B0321-09

DEVICE INFORMATION

PIN ASSIGNMENT

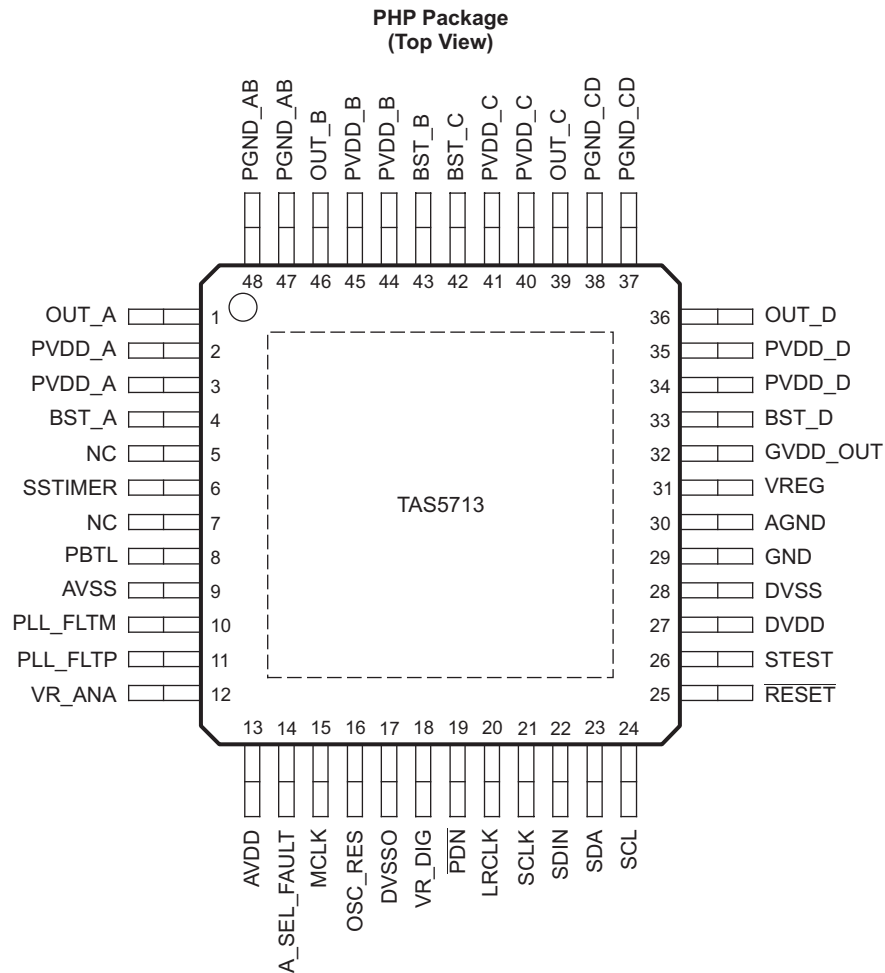

P0075-09

PIN FUNCTIONS

| PIN | | TYPE ⁽¹⁾ | 5-V TOLERANT | TERMINATION ⁽²⁾ | DESCRIPTION |
|-------------|-----|---------------------|-----------------|----------------------------|---|
| NAME | NO. | | | | |
| AGND | 30 | P | | | Local analog ground for power stage |
| A_SEL_FAULT | 14 | DIO | | | This pin is monitored on the rising edge of $\overline{\text{RESET}}$. A value of 0 (15-k Ω pulldown) sets the I ² C device address to 0x34 and a value of 1 (15-k Ω pullup) sets it to 0x36. this dual-function pin can be programmed to output internal power-stage errors. |
| AVDD | 13 | P | | | 3.3-V analog power supply |
| AVSS | 9 | P | | | Analog 3.3-V supply ground |
| BST_A | 4 | P | | | High-side bootstrap supply for half-bridge A |
| BST_B | 43 | P | | | High-side bootstrap supply for half-bridge B |
| BST_C | 42 | P | | | High-side bootstrap supply for half-bridge C |
| BST_D | 33 | P | | | High-side bootstrap supply for half-bridge D |
| DVDD | 27 | P | | | 3.3-V digital power supply |
| DVSS | 28 | P | | | Digital ground |

(1) TYPE: A = analog; D = 3.3-V digital; P = power/ground/decoupling; I = input; O = output

(2) All pullups are weak pullups and all pulldowns are weak pulldowns. The pullups and pulldowns are included to assure proper input logic levels if the pins are left unconnected (pullups \rightarrow logic 1 input; pulldowns \rightarrow logic 0 input).

PIN FUNCTIONS (continued)

| PIN | | TYPE ⁽¹⁾ | 5-V TOLERANT | TERMINATION ⁽²⁾ | DESCRIPTION |
|---------------------------|--------|---------------------|-----------------|----------------------------|---|
| NAME | NO. | | | | |
| DVSSO | 17 | P | | | Oscillator ground |
| GND | 29 | P | | | Analog ground for power stage |
| GVDD_OUT | 32 | P | | | Gate drive internal regulator output |
| LRCLK | 20 | DI | 5-V | Pulldown | Input serial audio data left/right clock (sample-rate clock) |
| MCLK | 15 | DI | 5-V | Pulldown | Master clock input |
| NC | 5, 7 | – | | | No connect |
| OSC_RES | 16 | AO | | | Oscillator trim resistor. Connect an 18.2-kΩ, 1% resistor to DVSSO. |
| OUT_A | 1 | O | | | Output, half-bridge A |
| OUT_B | 46 | O | | | Output, half-bridge B |
| OUT_C | 39 | O | | | Output, half-bridge C |
| OUT_D | 36 | O | | | Output, half-bridge D |
| PBTL | 8 | DI | | | Low means BTL or SE mode; high means PBTL mode. Information goes directly to power stage. |
| $\overline{\text{PDN}}$ | 19 | DI | 5-V | Pullup | Power down, active-low. $\overline{\text{PDN}}$ prepares the device for loss of power supplies by shutting down the noise shaper and initiating the PWM stop sequence. |
| PGND_AB | 47, 48 | P | | | Power ground for half-bridges A and B |
| PGND_CD | 37, 38 | P | | | Power ground for half-bridges C and D |
| PLL_FLTM | 10 | AO | | | PLL negative loop-filter terminal |
| PLL_FLTP | 11 | AO | | | PLL positive loop-filter terminal |
| PVDD_A | 2, 3 | P | | | Power-supply input for half-bridge output A |
| PVDD_B | 44, 45 | P | | | Power-supply input for half-bridge output B |
| PVDD_C | 40, 41 | P | | | Power-supply input for half-bridge output C |
| PVDD_D | 34, 35 | P | | | Power-supply input for half-bridge output D |
| $\overline{\text{RESET}}$ | 25 | DI | 5-V | Pullup | Reset, active-low. A system reset is generated by applying a logic low to this pin. RESET is an asynchronous control signal that restores the DAP to its default conditions and places the PWM in the hard-mute (high-impedance) state. |
| SCL | 24 | DI | 5-V | | I ² C serial control clock input |
| SCLK | 21 | DI | 5-V | Pulldown | Serial audio-data clock (shift clock). SCLK is the serial-audio-port input-data bit clock. |
| SDA | 23 | DIO | 5-V | | I ² C serial control data interface input/output |
| SDIN | 22 | DI | 5-V | Pulldown | Serial audio data input. SDIN supports three discrete (stereo) data formats. |
| SSTIMER | 6 | AI | | | Controls ramp time of OUT_x to minimize pop. Leave this pin floating for BD mode. Requires capacitor of 2.2 nF to GND in AD mode. The capacitor determines the ramp time. |
| STEST | 26 | DI | | | Factory test pin. Connect directly to DVSS. |
| VR_ANA | 12 | P | | | Internally regulated 1.8-V analog supply voltage. This pin must not be used to power external devices. |
| VR_DIG | 18 | P | | | Internally regulated 1.8-V digital supply voltage. This pin must not be used to power external devices. |
| VREG | 31 | P | | | Digital regulator output. Not to be used for powering external circuitry. |

ABSOLUTE MAXIMUM RATINGS

over operating free-air temperature range (unless otherwise noted) ⁽¹⁾

| | | VALUE | UNIT |
|---|---|-----------------------------------|------|
| Supply voltage | DVDD, AVDD | –0.3 to 3.6 | V |
| | PVDD_x | –0.3 to 30 | V |
| Input voltage | 3.3-V digital input | –0.5 to DVDD + 0.5 | V |
| | 5-V tolerant ⁽²⁾ digital input (except MCLK) | –0.5 to DVDD + 2.5 ⁽³⁾ | |
| | 5-V tolerant MCLK input | –0.5 to AVDD + 2.5 ⁽³⁾ | |
| OUT_x to PGND_x | | 32 ⁽⁴⁾ | V |
| BST_x to PGND_x | | 43 ⁽⁴⁾ | V |
| Input clamp current, I _{IK} | | ±20 | mA |
| Output clamp current, I _{OK} | | ±20 | mA |
| Operating free-air temperature | | 0 to 85 | °C |
| Operating junction temperature range | | 0 to 150 | °C |
| Storage temperature range, T _{stg} | | –40 to 125 | °C |

- (1) Stresses beyond those listed under *absolute ratings* may cause permanent damage to the device. These are stress ratings only and functional operation of the device at these or any other conditions beyond those indicated under *recommended operation conditions* are not implied. Exposure to *absolute-maximum conditions* for extended periods may affect device reliability.
- (2) 5-V tolerant inputs are PDN, RESET, SCLK, LRCLK, MCLK, SDIN, SDA, and SCL.
- (3) Maximum pin voltage should not exceed 6 V.
- (4) DC voltage + peak ac waveform measured at the pin should be below the allowed limit for all conditions.

THERMAL INFORMATION

| THERMAL METRIC ⁽¹⁾⁽²⁾ | | TAS5713 | UNITS |
|----------------------------------|--|---------------|-------|
| | | PHP (48 PINS) | |
| θ_{JA} | Junction-to-ambient thermal resistance | 29.1 | °C/W |
| $\theta_{Jc\text{top}}$ | Junction-to-case (top) thermal resistance | 18.8 | |
| θ_{JB} | Junction-to-board thermal resistance | 11 | |
| ψ_{JT} | Junction-to-top characterization parameter | 0.2 | |
| ψ_{JB} | Junction-to-board characterization parameter | 6.5 | |
| $\theta_{Jc\text{bot}}$ | Junction-to-case (bottom) thermal resistance | 0.5 | |

- (1) For more information about traditional and new thermal metrics, see the *IC Package Thermal Metrics* application report, [SPRA953](#).
- (2) For thermal estimates of this device based on PCB copper area, see the [TI PCB Thermal Calculator](#).

RECOMMENDED OPERATING CONDITIONS

| | | MIN | NOM | MAX | UNIT |
|-------------------------------|--------------------------------------|---|-----|-----|----------|
| Digital/analog supply voltage | DVDD, AVDD | 3 | 3.3 | 3.6 | V |
| Half-bridge supply voltage | PVDD_x | 8 | | 26 | V |
| V _{IH} | High-level input voltage | 2 | | | V |
| V _{IL} | Low-level input voltage | | | 0.8 | V |
| T _A | Operating ambient temperature range | 0 | | 85 | °C |
| T _J ⁽¹⁾ | Operating junction temperature range | 0 | | 125 | °C |
| R _L (BTL) | Load impedance | Output filter: L = 15 μ H, C = 680 nF | | | Ω |
| R _L (PBTL) | Load impedance | Output filter: L = 15 μ H, C = 680 nF | | | Ω |
| L _O (BTL) | Output-filter inductance | Minimum output inductance under short-circuit condition | | | μ H |

- (1) Continuous operation above the recommended junction temperature may result in reduced reliability and/or lifetime of the device.

PWM OPERATION AT RECOMMENDED OPERATING CONDITIONS

| PARAMETER | TEST CONDITIONS | VALUE | UNIT |
|--------------------|---|-------|------|
| Output sample rate | 11.025/22.05/44.1-kHz data rate $\pm 2\%$ | 352.8 | kHz |
| | 48/24/12/8/16/32-kHz data rate $\pm 2\%$ | 384 | |

PLL INPUT PARAMETERS AND EXTERNAL FILTER COMPONENTS

| PARAMETER | TEST CONDITIONS | MIN | TYP | MAX | UNIT |
|---|----------------------|--------|-----|--------|----------|
| f_{MCLKI} MCLK frequency | | 2.8224 | | 24.576 | MHz |
| MCLK duty cycle | | 40% | 50% | 60% | |
| $t_r / t_f(MCLK)$ Rise/fall time for MCLK | | | | 5 | ns |
| LRCLK allowable drift before LRCLK reset | | | | 4 | MCLKs |
| External PLL filter capacitor C1 | SMD 0603 X7R | | 47 | | nF |
| External PLL filter capacitor C2 | SMD 0603 X7R | | 4.7 | | nF |
| External PLL filter resistor R | SMD 0603, metal film | | 470 | | Ω |

ELECTRICAL CHARACTERISTICS
DC Characteristics
 $T_A = 25^\circ$, $PVCC_x = 18$ V, $DVDD = AVDD = 3.3$ V, $R_L = 8$ Ω , BTL AD mode, $f_S = 48$ kHz (unless otherwise noted)

| PARAMETER | | TEST CONDITIONS | MIN | TYP | MAX | UNIT |
|------------------------------------|--|---|-------------------------------------|------|-------------------|------------------|
| V_{OH} | High-level output voltage | A_SEL_FAULT and SDA | $I_{OH} = -4$ mA DVDD = 3 V | 2.4 | | V |
| V_{OL} | Low-level output voltage | A_SEL_FAULT and SDA | $I_{OL} = 4$ mA DVDD = 3 V | | 0.5 | V |
| I_{IL} | Low-level input current | | $V_I < V_{IL}$; DVDD = AVDD = 3.6V | | 75 | μ A |
| I_{IH} | High-level input current | | $V_I > V_{IH}$; DVDD = AVDD = 3.6V | | 75 ⁽¹⁾ | μ A |
| I_{DD} | 3.3 V supply current | 3.3 V supply voltage (DVDD, AVDD) | Normal mode | 48 | 83 | mA |
| | | | Reset (RESET = low, PDN = high) | 26 | 40 | |
| I_{PVDD} | Supply current | No load (PVDD_x) | Normal mode | 41 | 75 | mA |
| | | | Reset (RESET = low, PDN = high) | 5 | 13 | |
| $r_{DS(on)}$ ⁽²⁾ | Drain-to-source resistance, LS | $T_J = 25^\circ\text{C}$, includes metallization resistance | | 110 | | m Ω |
| | Drain-to-source resistance, HS | $T_J = 25^\circ\text{C}$, includes metallization resistance | | 110 | | |
| I/O Protection | | | | | | |
| V_{uvp} | Undervoltage protection limit | PVDD falling | | 7.2 | | V |
| $V_{uvp,hyst}$ | Undervoltage protection limit | PVDD rising | | 7.6 | | V |
| OTE ⁽³⁾ | Overtemperature error | | | 150 | | $^\circ\text{C}$ |
| OTE _{HYST} ⁽³⁾ | Extra temperature drop required to recover from error | | | 30 | | $^\circ\text{C}$ |
| OLPC | Overload protection counter | $f_{PWM} = 384$ kHz | | 0.63 | | ms |
| I_{OC} | Overcurrent limit protection | | | 4.5 | | A |
| I_{OCT} | Overcurrent response time | | | 150 | | ns |
| R_{PD} | Internal pulldown resistor at the output of each half-bridge | Connected when drivers are tristated to provide bootstrap capacitor charge. | | 3 | | k Ω |

(1) I_{IH} for the PBTL pin has a maximum limit of 200 μ A due to an internal pulldown on the pin.

(2) This does not include bond-wire or pin resistance.

(3) Specified by design

AC Characteristics (BTL, PBTL)

PVDD_x = 18 V, BTL AD mode, $f_s = 48$ kHz, $R_L = 8 \Omega$, $R_{OCP} = 22$ k Ω , $C_{BST} = 33$ nF, audio frequency = 1 kHz, AES17 filter, $f_{PWM} = 384$ kHz, $T_A = 25^\circ\text{C}$ (unless otherwise specified). All performance is in accordance with recommended operating conditions (unless otherwise specified).

| PARAMETER | | TEST CONDITIONS | MIN | TYP | MAX | UNIT |
|----------------|--------------------------------------|--|-----|-------|-----|---------------|
| P _O | Power output per channel | PVDD = 18 V, 10% THD, 1-kHz input signal | | 21.5 | | W |
| | | PVDD = 18 V, 7% THD, 1-kHz input signal | | 20.3 | | |
| | | PVDD = 12 V, 10% THD, 1-kHz input signal | | 9.6 | | |
| | | PVDD = 12 V, 7% THD, 1-kHz input signal | | 9.1 | | |
| | | PVDD = 8 V, 10% THD, 1-kHz input signal | | 4.2 | | |
| | | PVDD = 8 V, 7% THD, 1-kHz input signal | | 4 | | |
| | | PBTL mode, PVDD = 12 V, $R_L = 4 \Omega$, 10% THD, 1-kHz input signal | | 18.7 | | |
| | | PBTL mode, PVDD = 12 V, $R_L = 4 \Omega$, 7% THD, 1-kHz input signal | | 17.7 | | |
| | | PBTL mode, PVDD = 18 V, $R_L = 4 \Omega$, 10% THD, 1-kHz input signal | | 41.5 | | |
| | | PBTL mode, PVDD = 18 V, $R_L = 4 \Omega$, 7% THD, 1-kHz input signal | | 39 | | |
| THD+N | Total harmonic distortion + noise | PVDD = 18 V, P _O = 1 W | | 0.07% | | |
| | | PVDD = 12 V, P _O = 1 W | | 0.03% | | |
| | | PVDD = 8 V, P _O = 1 W | | 0.1% | | |
| V _n | Output integrated noise (rms) | A-weighted | | 56 | | μV |
| | Crosstalk | P _O = 0.25 W, f = 1 kHz (BD Mode) | | -82 | | dB |
| | | P _O = 0.25 W, f = 1 kHz (AD Mode) | | -69 | | dB |
| SNR | Signal-to-noise ratio ⁽¹⁾ | A-weighted, f = 1 kHz, maximum power at THD < 1% | | 106 | | dB |

(1) SNR is calculated relative to 0-dBFS input level.

SERIAL AUDIO PORTS SLAVE MODE

over recommended operating conditions (unless otherwise noted)

| PARAMETER | | TEST CONDITIONS | MIN | TYP | MAX | UNIT |
|--------------|---|-----------------------|-------|-----|--------|-------------|
| f_{SCLKIN} | Frequency, SCLK $32 \times f_S$, $48 \times f_S$, $64 \times f_S$ | $C_L = 30 \text{ pF}$ | 1.024 | | 12.288 | MHz |
| t_{su1} | Setup time, LRCLK to SCLK rising edge | | 10 | | | ns |
| t_{h1} | Hold time, LRCLK from SCLK rising edge | | 10 | | | ns |
| t_{su2} | Setup time, SDIN to SCLK rising edge | | 10 | | | ns |
| t_{h2} | Hold time, SDIN from SCLK rising edge | | 10 | | | ns |
| | LRCLK frequency | | 8 | 48 | 48 | kHz |
| | SCLK duty cycle | | 40% | 50% | 60% | |
| | LRCLK duty cycle | | 40% | 50% | 60% | |
| | SCLK rising edges between LRCLK rising edges | | 32 | | 64 | SCLK edges |
| $t_{(edge)}$ | LRCLK clock edge with respect to the falling edge of SCLK | | -1/4 | | 1/4 | SCLK period |
| t_r/t_f | Rise/fall time for SCLK/LRCLK | | | | 8 | ns |

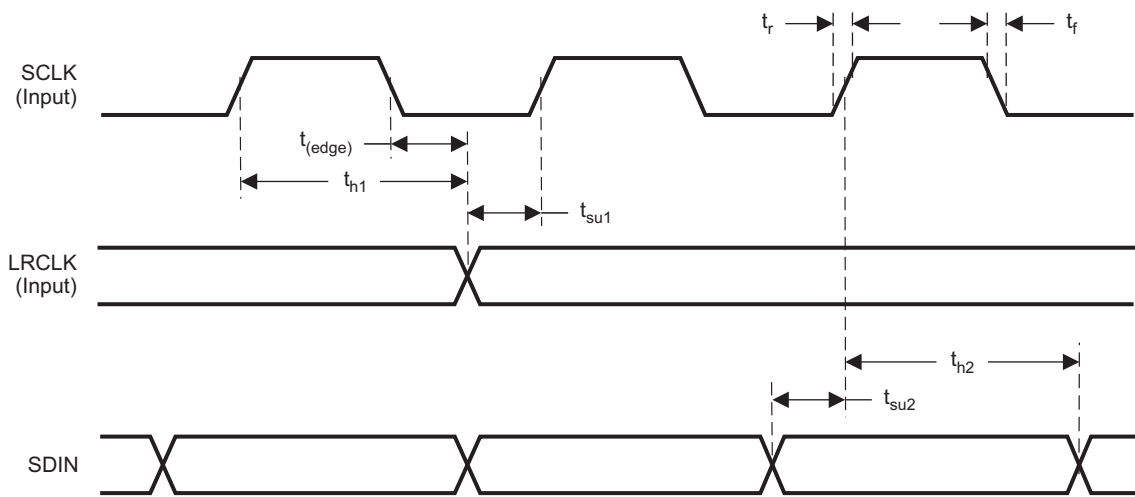

T0026-04

Figure 2. Slave-Mode Serial Data-Interface Timing

I²C SERIAL CONTROL PORT OPERATION

Timing characteristics for I²C Interface signals over recommended operating conditions (unless otherwise noted)

| PARAMETER | | TEST CONDITIONS | MIN | MAX | UNIT |
|--------------------|---|-----------------|-----|-----|------|
| f _{SCL} | Frequency, SCL | No wait states | | 400 | kHz |
| t _{w(H)} | Pulse duration, SCL high | | 0.6 | | μs |
| t _{w(L)} | Pulse duration, SCL low | | 1.3 | | μs |
| t _r | Rise time, SCL and SDA | | | 300 | ns |
| t _f | Fall time, SCL and SDA | | | 300 | ns |
| t _{su1} | Setup time, SDA to SCL | | 100 | | ns |
| t _{h1} | Hold time, SCL to SDA | | 0 | | ns |
| t _(buf) | Bus free time between stop and start conditions | | 1.3 | | μs |
| t _{su2} | Setup time, SCL to start condition | | 0.6 | | μs |
| t _{h2} | Hold time, start condition to SCL | | 0.6 | | μs |
| t _{su3} | Setup time, SCL to stop condition | | 0.6 | | μs |
| C _L | Load capacitance for each bus line | | | 400 | pF |

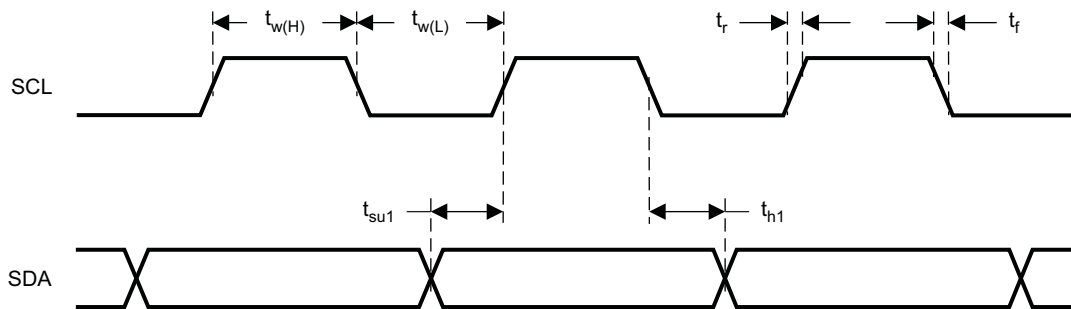

T0027-01

Figure 3. SCL and SDA Timing

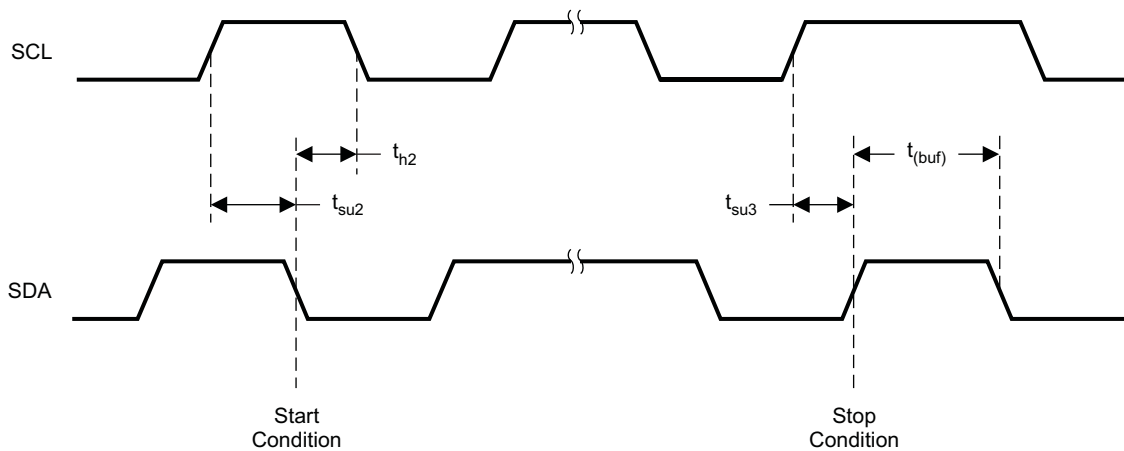

T0028-01

Figure 4. Start and Stop Conditions Timing

RESET TIMING ($\overline{\text{RESET}}$)

Control signal parameters over recommended operating conditions (unless otherwise noted). Please refer to Recommended Use Model section on usage of all terminals.

| | PARAMETER | MIN | TYP | MAX | UNIT |
|----------------------------------|--|-----|-----|------|---------------|
| $t_w(\overline{\text{RESET}})$ | Pulse duration, $\overline{\text{RESET}}$ active | 100 | | | μs |
| $t_d(\text{I}^2\text{C_ready})$ | Time to enable I ² C | | | 12.0 | ms |

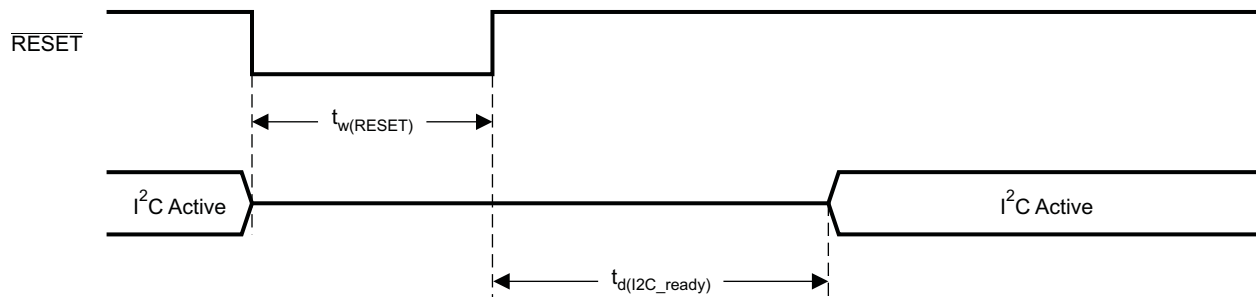

System Initialization.
Enable via I²C.

T0421-01

NOTES: On power up, it is recommended that the TAS5713 $\overline{\text{RESET}}$ be held LOW for at least 100 μs after DVDD has reached 3 V.

If $\overline{\text{RESET}}$ is asserted LOW while $\overline{\text{PDN}}$ is LOW, then $\overline{\text{RESET}}$ must continue to be held LOW for at least 100 μs after $\overline{\text{PDN}}$ is deasserted (HIGH).

Figure 5. Reset Timing

TYPICAL CHARACTERISTICS, BTL CONFIGURATION, 8 Ω

**TOTAL HARMONIC DISTORTION + NOISE
vs
FREQUENCY**

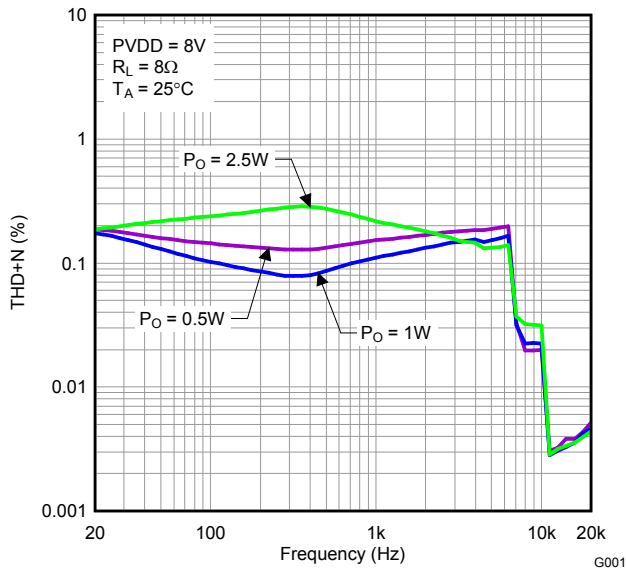

Figure 6.

**TOTAL HARMONIC DISTORTION + NOISE
vs
FREQUENCY**

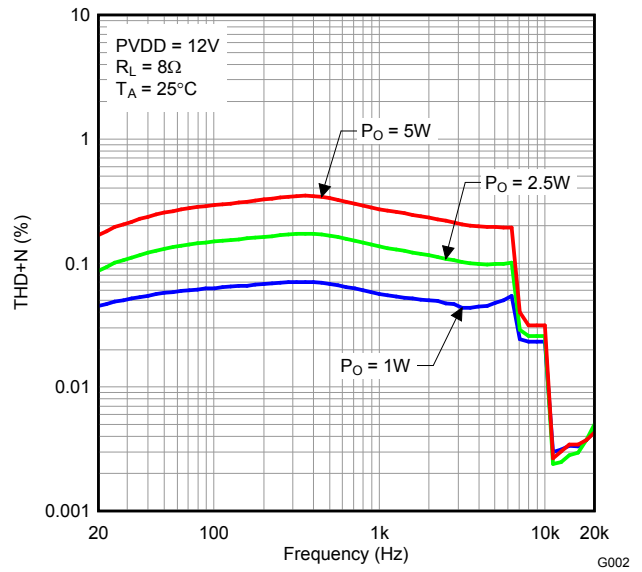

Figure 7.

**TOTAL HARMONIC DISTORTION + NOISE
vs
FREQUENCY**

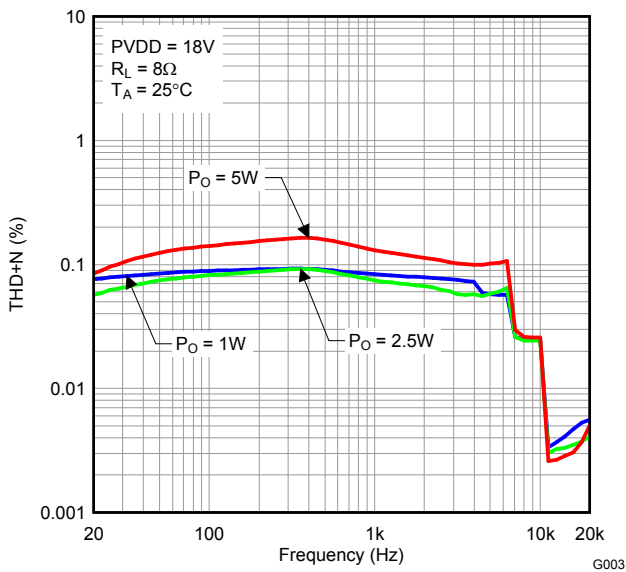

Figure 8.

**TOTAL HARMONIC DISTORTION + NOISE
vs
FREQUENCY**

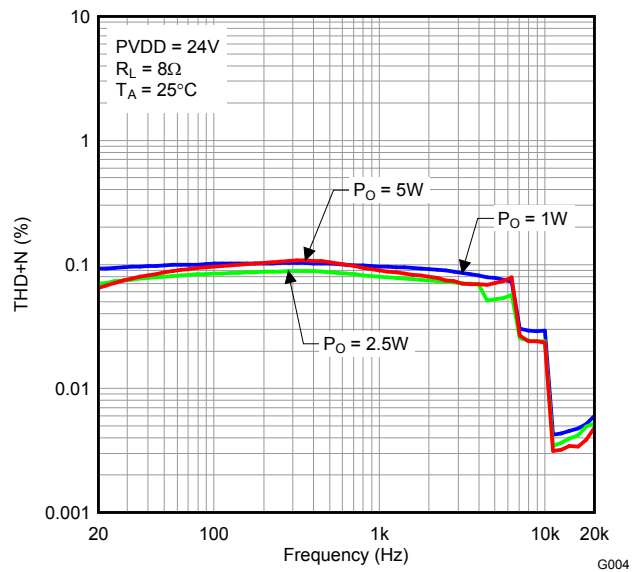

Figure 9.

TYPICAL CHARACTERISTICS, BTL CONFIGURATION, 8 Ω (continued)

TOTAL HARMONIC DISTORTION + NOISE vs OUTPUT POWER

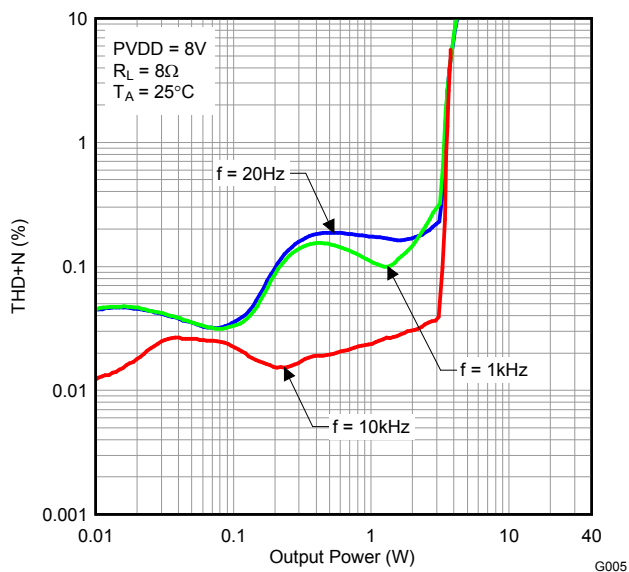

Figure 10.

TOTAL HARMONIC DISTORTION + NOISE vs OUTPUT POWER

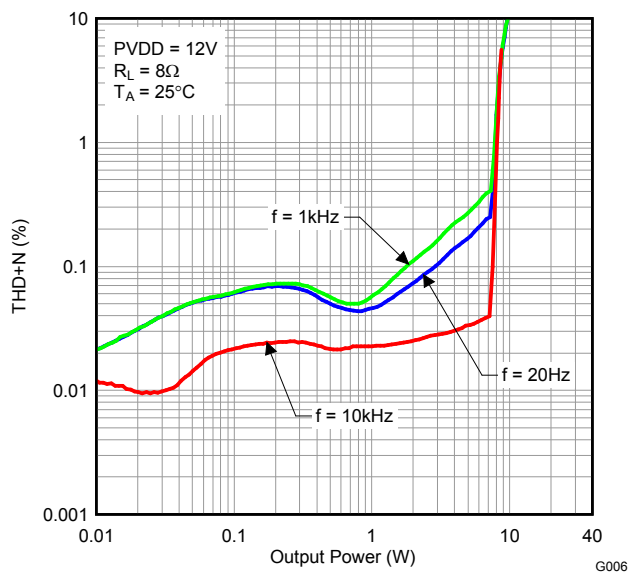

Figure 11.

TOTAL HARMONIC DISTORTION + NOISE vs OUTPUT POWER

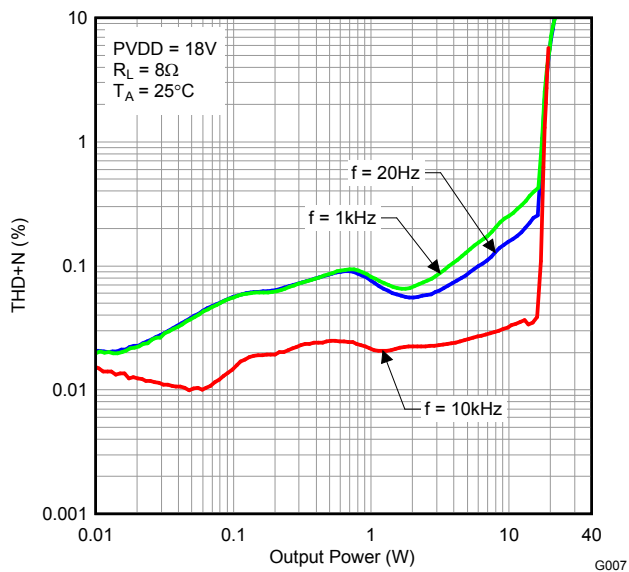

Figure 12.

TOTAL HARMONIC DISTORTION + NOISE vs OUTPUT POWER

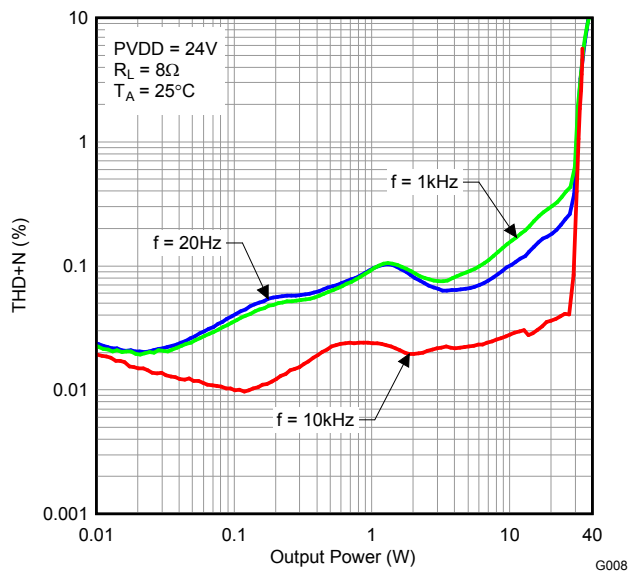
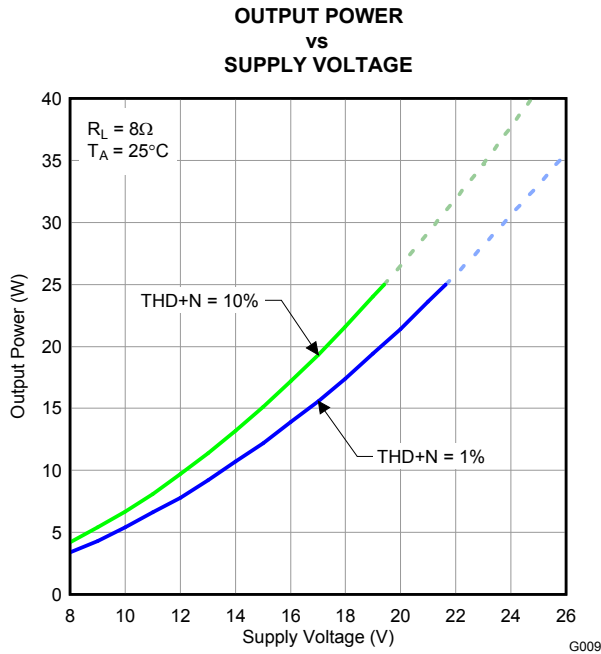

Figure 13.

TYPICAL CHARACTERISTICS, BTL CONFIGURATION, 8 Ω (continued)



NOTE: Dashed lines represent thermally limited region.

Figure 14.

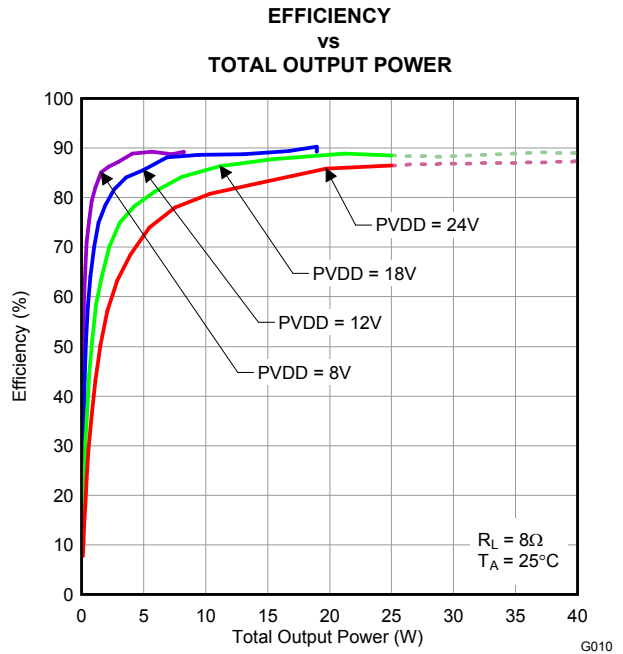

NOTE: Dashed lines represent thermally limited region.

Figure 15.

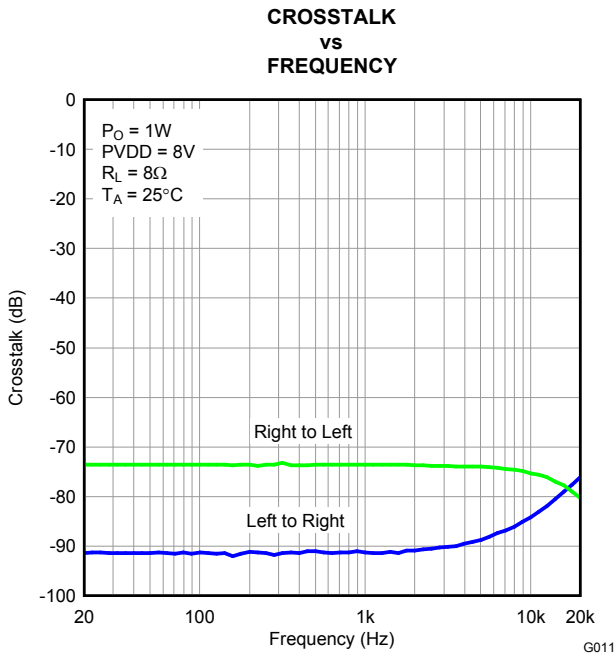

Figure 16.

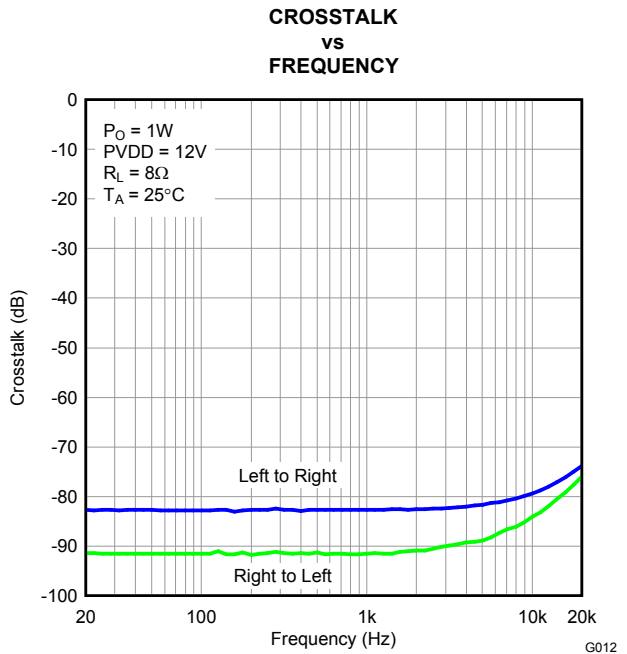

Figure 17.

TYPICAL CHARACTERISTICS, BTL CONFIGURATION, 8 Ω (continued)

CROSSTALK
vs
FREQUENCY

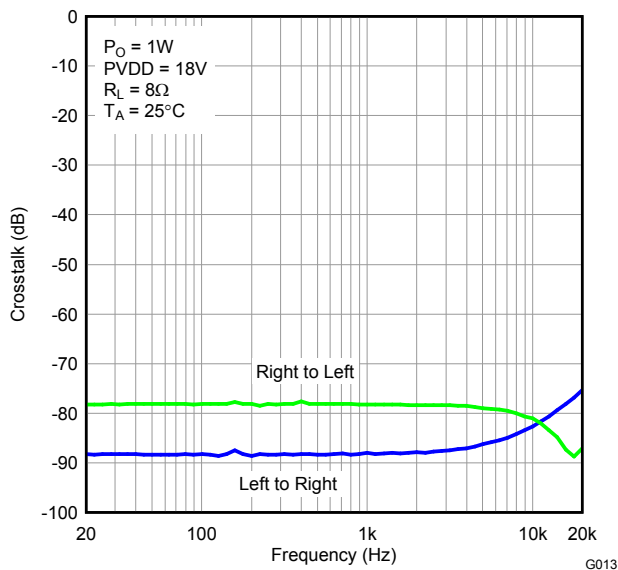

Figure 18.

CROSSTALK
vs
FREQUENCY

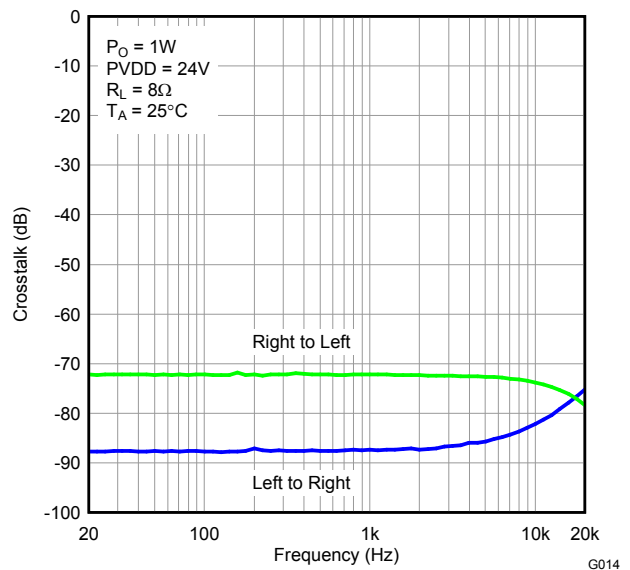

Figure 19.

TYPICAL CHARACTERISTICS, BTL CONFIGURATION, 4 Ω

**TOTAL HARMONIC DISTORTION + NOISE
vs
FREQUENCY**

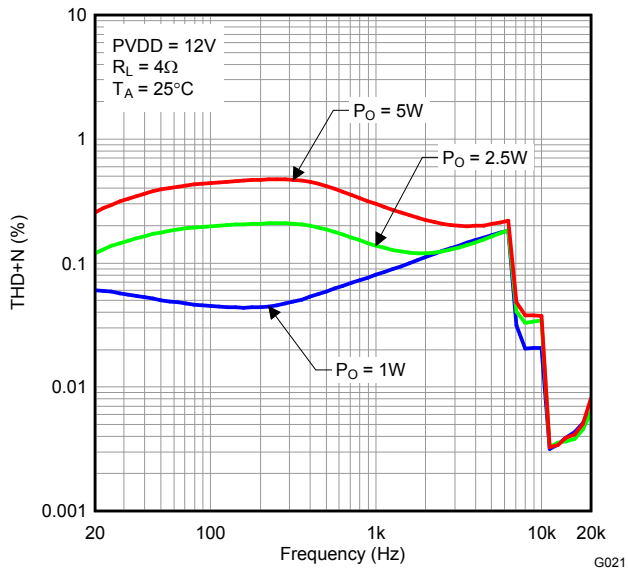

Figure 20.

**TOTAL HARMONIC DISTORTION + NOISE
vs
FREQUENCY**

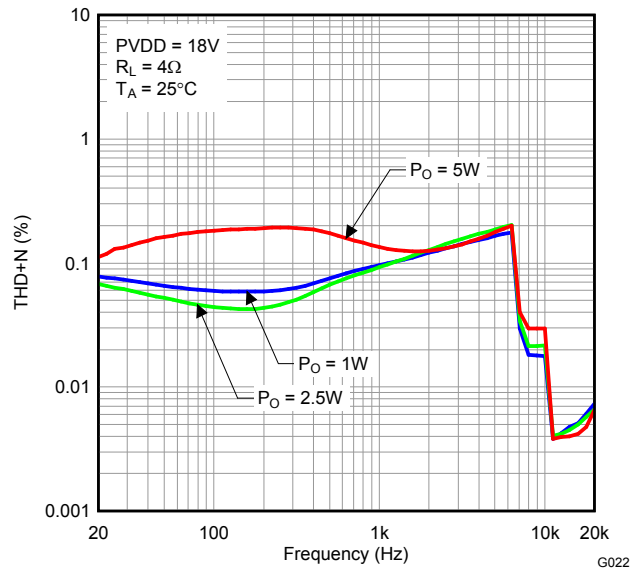

Figure 21.

**TOTAL HARMONIC DISTORTION + NOISE
vs
OUTPUT POWER**

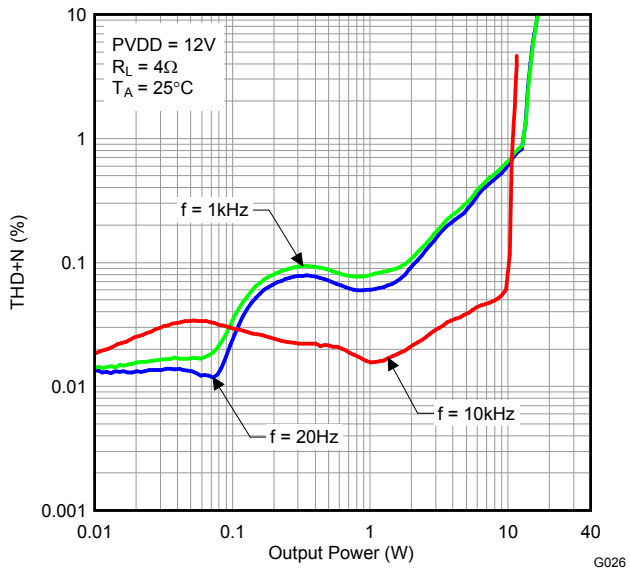

Figure 22.

**TOTAL HARMONIC DISTORTION + NOISE
vs
OUTPUT POWER**

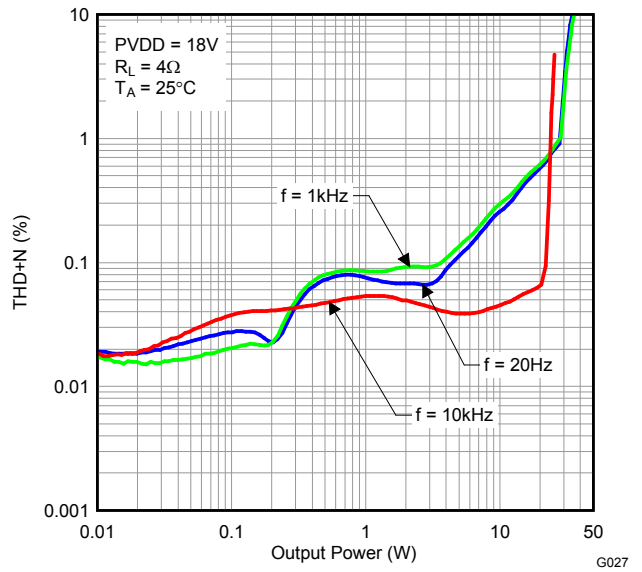

Figure 23.

TYPICAL CHARACTERISTICS, BTL CONFIGURATION, 4 Ω (continued)

CROSSTALK
vs
FREQUENCY

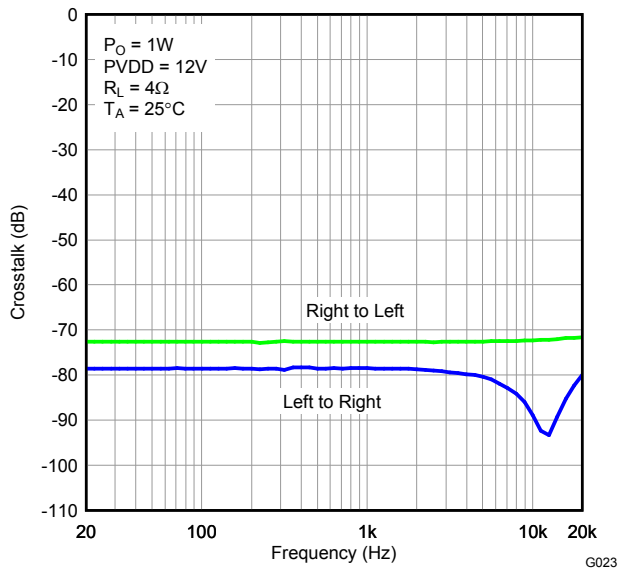

Figure 24.

CROSSTALK
vs
FREQUENCY

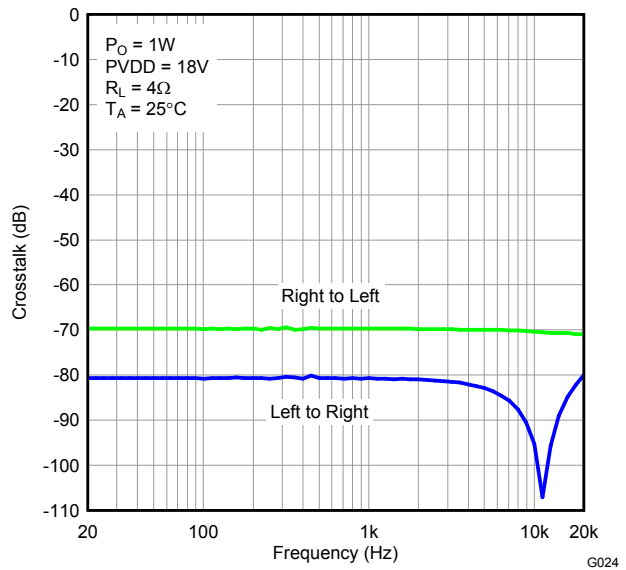

Figure 25.

TYPICAL CHARACTERISTICS, PBTL CONFIGURATION, 4 Ω

**TOTAL HARMONIC DISTORTION + NOISE
vs
FREQUENCY**

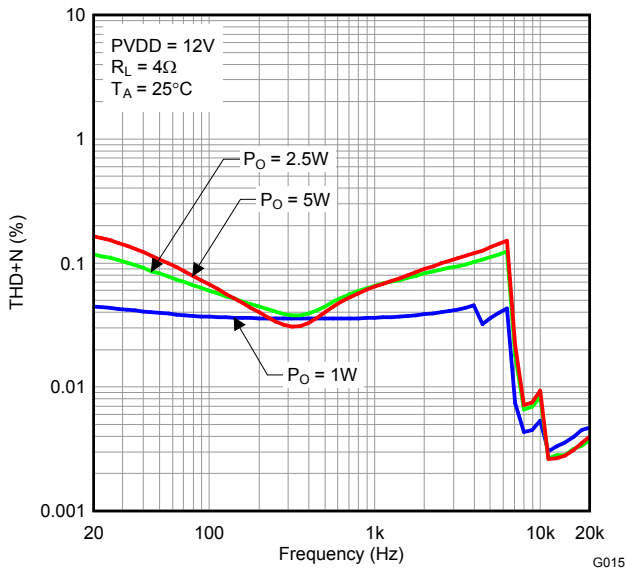

Figure 26.

**TOTAL HARMONIC DISTORTION + NOISE
vs
FREQUENCY**

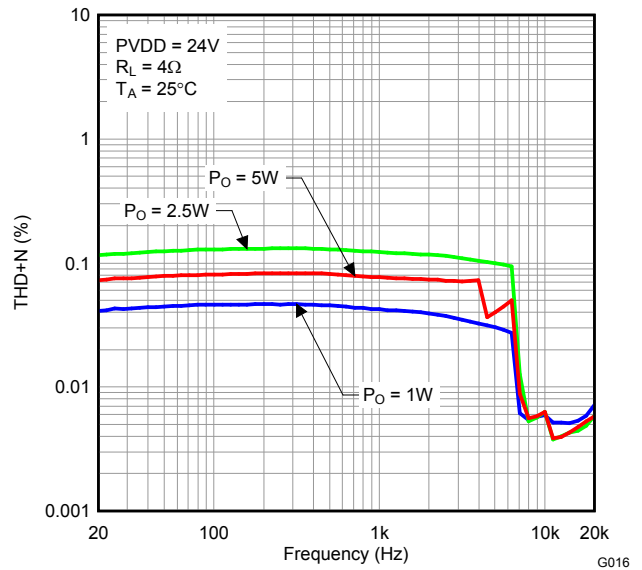

Figure 27.

**TOTAL HARMONIC DISTORTION + NOISE
vs
OUTPUT POWER**

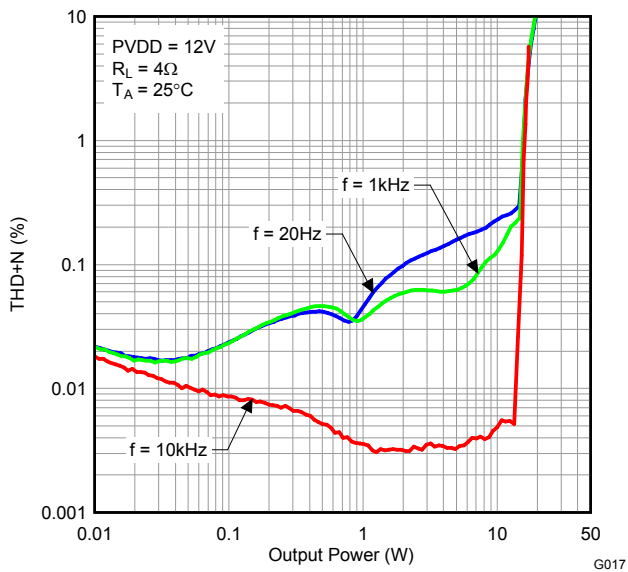

Figure 28.

**TOTAL HARMONIC DISTORTION + NOISE
vs
OUTPUT POWER**

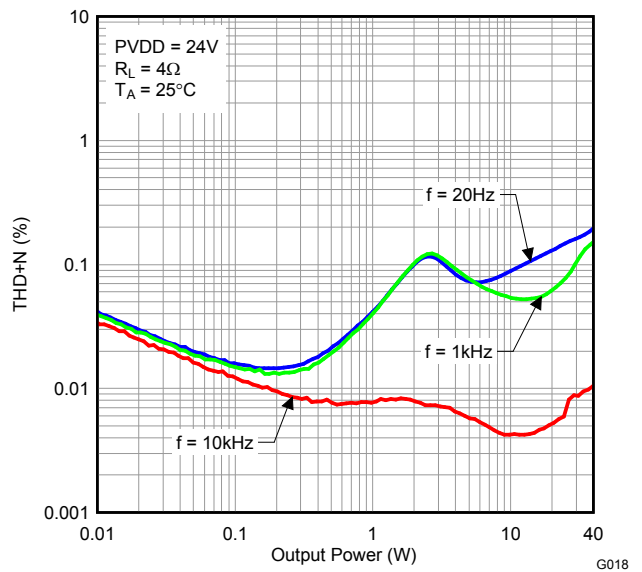
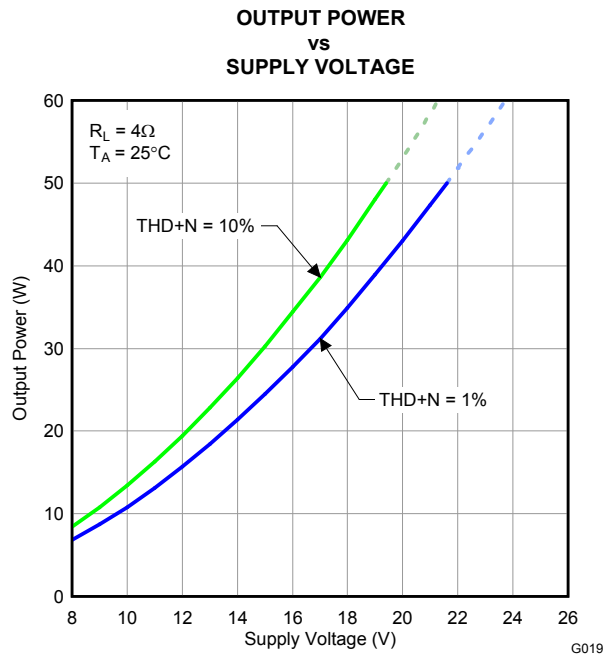

Figure 29.

TYPICAL CHARACTERISTICS, PBTL CONFIGURATION, 4 Ω (continued)



NOTE: Dashed lines represent thermally limited region.

Figure 30.

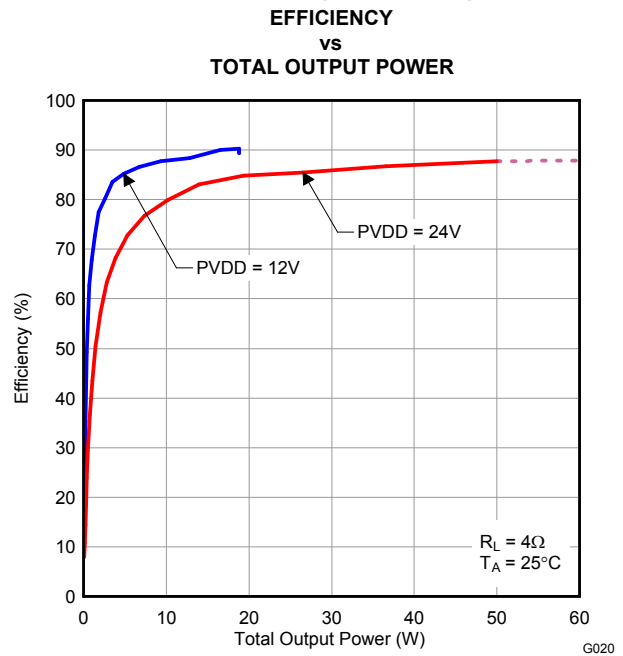

NOTE: Dashed line represents thermally limited region.

Figure 31.

DETAILED DESCRIPTION

POWER SUPPLY

To facilitate system design, the TAS5713 needs only a 3.3-V supply in addition to the (typical) 18-V power-stage supply. An internal voltage regulator provides suitable voltage levels for the gate drive circuitry. Additionally, all circuitry requiring a floating voltage supply, e.g., the high-side gate drive, is accommodated by built-in bootstrap circuitry requiring only a few external capacitors.

In order to provide good electrical and acoustical characteristics, the PWM signal path for the output stage is designed as identical, independent half-bridges. For this reason, each half-bridge has separate bootstrap pins (BST_x), and power-stage supply pins (PVDD_x). The gate-drive voltage (GVDD_OUT) is derived from the PVDD voltage. Special attention should be paid to placing all decoupling capacitors as close to their associated pins as possible. Inductance between the power-supply pins and decoupling capacitors must be avoided.

For a properly functioning bootstrap circuit, a small ceramic capacitor must be connected from each bootstrap pin (BST_x) to the power-stage output pin (OUT_x). When the power-stage output is low, the bootstrap capacitor is charged through an internal diode connected between the gate-drive regulator output pin (GVDD_OUT) and the bootstrap pin. When the power-stage output is high, the bootstrap capacitor potential is shifted above the output potential and thus provides a suitable voltage supply for the high-side gate driver. In an application with PWM switching frequencies in the range from 352 kHz to 384 kHz, it is recommended to use 33-nF, X7R ceramic capacitors, size 0603 or 0805, for the bootstrap supply. These 33-nF capacitors ensure sufficient energy storage, even during minimal PWM duty cycles, to keep the high-side power-stage FET (LDMOS) fully turned on during the remaining part of the PWM cycle.

Special attention should be paid to the power-stage power supply; this includes component selection, PCB placement, and routing. As indicated, each half-bridge has independent power-stage supply pins (PVDD_x). For optimal electrical performance, EMI compliance, and system reliability, it is important that each PVDD_x pin is decoupled with a 100-nF, X7R ceramic capacitor placed as close as possible to each supply pin.

The TAS5713 is fully protected against erroneous power-stage turnon due to parasitic gate charging.

I²C CHIP SELECT

A_SEL_FAULT is an input pin during power up. It can be pulled high (15-kΩ pullup) or low (15-kΩ pulldown). High indicates an I²C subaddress of 0x36, and low a subaddress of 0x34.

I²C Device Address Change Procedure

- Write to device address change enable register, 0xF8 with a value of 0xF9 A5 A5 A5.
- Write to device register 0xF9 with a value of 0x0000 00XX, where XX is the new address.
- Any writes after that should use the new device address XX.

SINGLE-FILTER PBTL MODE

The TAS5713 supports parallel BTL (PBTL) mode with OUT_A/OUT_B (and OUT_C/OUT_D) connected before the LC filter. In order to put the part in PBTL configuration, drive PBTL (pin 8) HIGH. This synchronizes the turnoff of half-bridges A and B (and similarly C/D) if an overcurrent condition is detected in either half-bridge. There is a pulldown resistor on the PBTL pin that configures the part in BTL mode if the pin is left floating.

PWM output multiplexers should be updated to set the device in PBTL mode. Output Mux Register (0x25) should be written with a value of 0x01 10 32 45. Also, the PWM shutdown register (0x19) should be written with a value of 0x3A.

DEVICE PROTECTION SYSTEM

Overcurrent (OC) Protection With Current Limiting

The device has independent, fast-reacting current detectors on all high-side and low-side power-stage FETs. The detector outputs are closely monitored by two protection systems. The first protection system controls the power stage in order to prevent the output current further increasing, i.e., it performs a cycle-by-cycle current-limiting function, rather than prematurely shutting down during combinations of high-level music transients and extreme

speaker load-impedance drops. If the high-current condition situation persists, i.e., the power stage is being overloaded, a second protection system triggers a latching shutdown, resulting in the power stage being set in the high-impedance (Hi-Z) state. The device returns to normal operation once the fault condition (i.e., a short circuit on the output) is removed. Current-limiting and overcurrent protection are not independent for half-bridges. That is, if the bridge-tied load between half-bridges A and B causes an overcurrent fault, half-bridges A, B, C, and D are shut down.

Overtemperature Protection

The TAS5713 has an overtemperature-protection system. If the device junction temperature exceeds 150°C (nominal), the device is put into thermal shutdown, resulting in all half-bridge outputs being set in the high-impedance (Hi-Z) state and `A_SEL_FAULT` being asserted low. The TAS5713 recovers automatically once the temperature drops approximately 30°C.

Undervoltage Protection (UVP) and Power-On Reset (POR)

The UVP and POR circuits of the TAS5713 fully protect the device in any power-up/down and brownout situation. While powering up, the POR circuit resets the overload circuit (OLP) and ensures that all circuits are fully operational when the PVDD and AVDD supply voltages reach 7.6 V and 2.7 V, respectively. Although PVDD and AVDD are independently monitored, a supply-voltage drop below the UVP threshold on AVDD or either PVDD pin results in all half-bridge outputs immediately being set in the high-impedance (Hi-Z) state and `A_SEL_FAULT` being asserted low.

FAULT INDICATION

`A_SEL_FAULT` is an input pin during power up. This pin can be programmed after RESET to be an output by writing 1 to bit 0 of I²C register 0x05. In that mode, the `A_SEL_FAULT` pin has the definition shown in [Table 1](#).

Any fault resulting in device shutdown is signaled by the `A_SEL_FAULT` pin going low (see [Table 1](#)). A latched version of this pin is available on D1 of register 0x02. This bit can be reset only by an I²C write.

Table 1. A_SEL_FAULT Output States

| <code>A_SEL_FAULT</code> | DESCRIPTION |
|--------------------------|--|
| 0 | Overcurrent (OC) or undervoltage (UVP) error or overtemperature error (OTE) or overvoltage error |
| 1 | No faults (normal operation) |

SSTIMER FUNCTIONALITY

The SSTIMER pin uses a capacitor connected between this pin and ground to control the output duty cycle when exiting all-channel shutdown. The capacitor on the SSTIMER pin is slowly charged through an internal current source, and the charge time determines the rate at which the output transitions from a near-zero duty cycle to the desired duty cycle. This allows for a smooth transition that minimizes audible pops and clicks. When the part is shut down, the drivers are placed in the high-impedance state and transition slowly down through a 3-kΩ resistor, similarly minimizing pops and clicks. The shutdown transition time is independent of the SSTIMER pin capacitance. Larger capacitors increase the start-up time, while capacitors smaller than 2.2 nF decrease the start-up time. The SSTIMER pin should be left floating for BD modulation.

CLOCK, AUTODETECTION, AND PLL

The TAS5713 is an I²S slave device. It accepts MCLK, SCLK, and LRCLK. The digital audio processor (DAP) supports all the sample rates and MCLK rates that are defined in the [clock control register](#).

The TAS5713 checks to verify that SCLK is a specific value of 32 f_S, 48 f_S, or 64 f_S. The DAP only supports a 1 × f_S LRCLK. The timing relationship of these clocks to SDIN is shown in subsequent sections. The clock section uses MCLK or the internal oscillator clock (when MCLK is unstable, out of range, or absent) to produce the internal clock (DCLK) running at 512 times the PWM switching frequency.

The DAP can autodetect and set the internal clock control logic to the appropriate settings for all supported clock rates as defined in the clock-control register.

The TAS5713 has robust clock error handling that uses the built-in trimmed oscillator clock to quickly detect changes/errors. Once the system detects a clock change/error, it mutes the audio (through a single-step mute) and then forces PLL to limp using the internal oscillator as a reference clock. Once the clocks are stable, the system autodetects the new rate and revert to normal operation. During this process, the default volume is restored in a single step (also called hard unmute). The ramp process can be programmed to ramp back slowly (also called soft unmute) as defined in volume register (0x0E).

SERIAL DATA INTERFACE

Serial data is input on SDIN. The PWM outputs are derived from SDIN. The TAS5713 DAP accepts serial data in 16-, 20-, or 24-bit left-justified, right-justified, and I²S serial data formats.

PWM SECTION

The TAS5713 DAP device uses noise-shaping and customized nonlinear correction algorithms to achieve high power efficiency and high-performance digital audio reproduction. The DAP uses a fourth-order noise shaper to increase dynamic range and SNR in the audio band. The PWM section accepts 24-bit PCM data from the DAP and outputs two BTL PWM audio output channels.

The PWM section has individual-channel dc-blocking filters that can be enabled and disabled. The filter cutoff frequency is less than 1 Hz. Individual-channel de-emphasis filters for 44.1 kHz and 48 kHz are included and can be enabled and disabled.

Finally, the PWM section has an adjustable maximum modulation limit of 93.8% to 99.2%.

For a detailed description of using audio processing features like DRC and EQ, see the User's Guide and TAS570X GDE software development tool documentation.

SERIAL INTERFACE CONTROL AND TIMING

I²S Timing

I²S timing uses LRCLK to define when the data being transmitted is for the left channel and when it is for the right channel. LRCLK is low for the left channel and high for the right channel. A bit clock running at 32, 48, or $64 \times f_s$ is used to clock in the data. There is a delay of one bit clock from the time the LRCLK signal changes state to the first bit of data on the data lines. The data is written MSB-first and is valid on the rising edge of bit clock. The DAP masks unused trailing data bit positions.

2-Channel I²S (Philips Format) Stereo Input

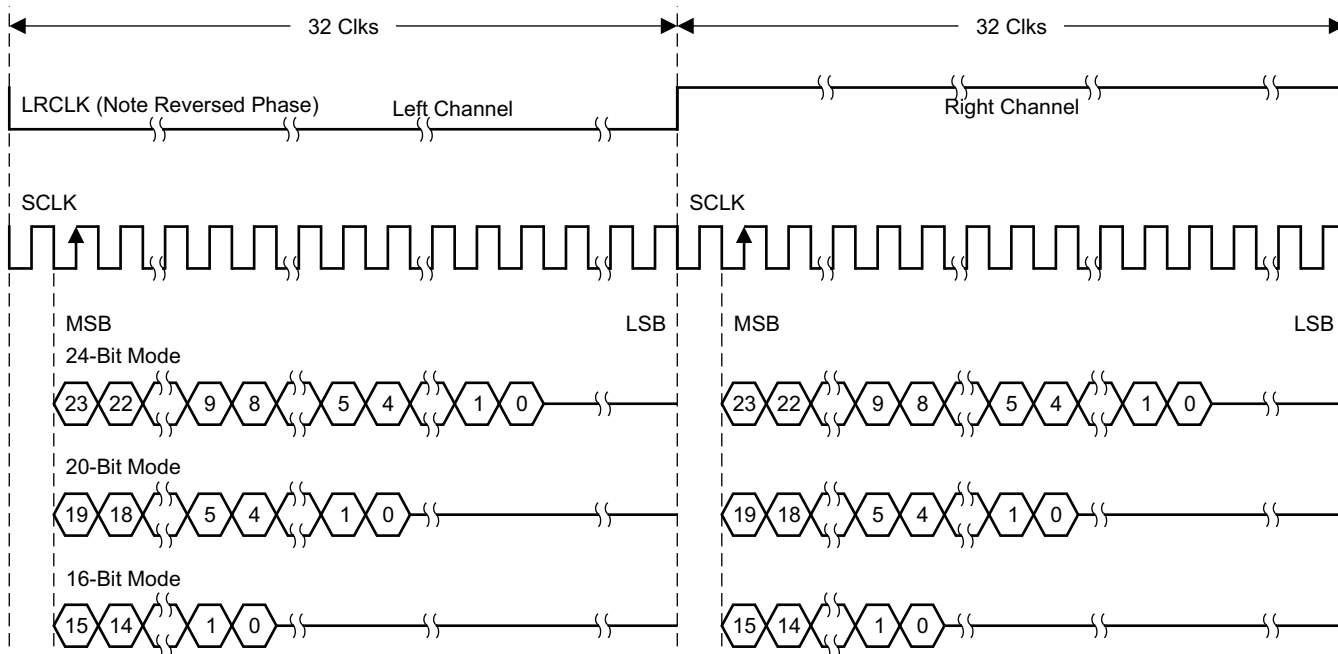

T0034-01

NOTE: All data presented in 2s-complement form with MSB first.

Figure 32. I²S 64-f_s Format

2-Channel I²S (Philips Format) Stereo Input/Output (24-Bit Transfer Word Size)

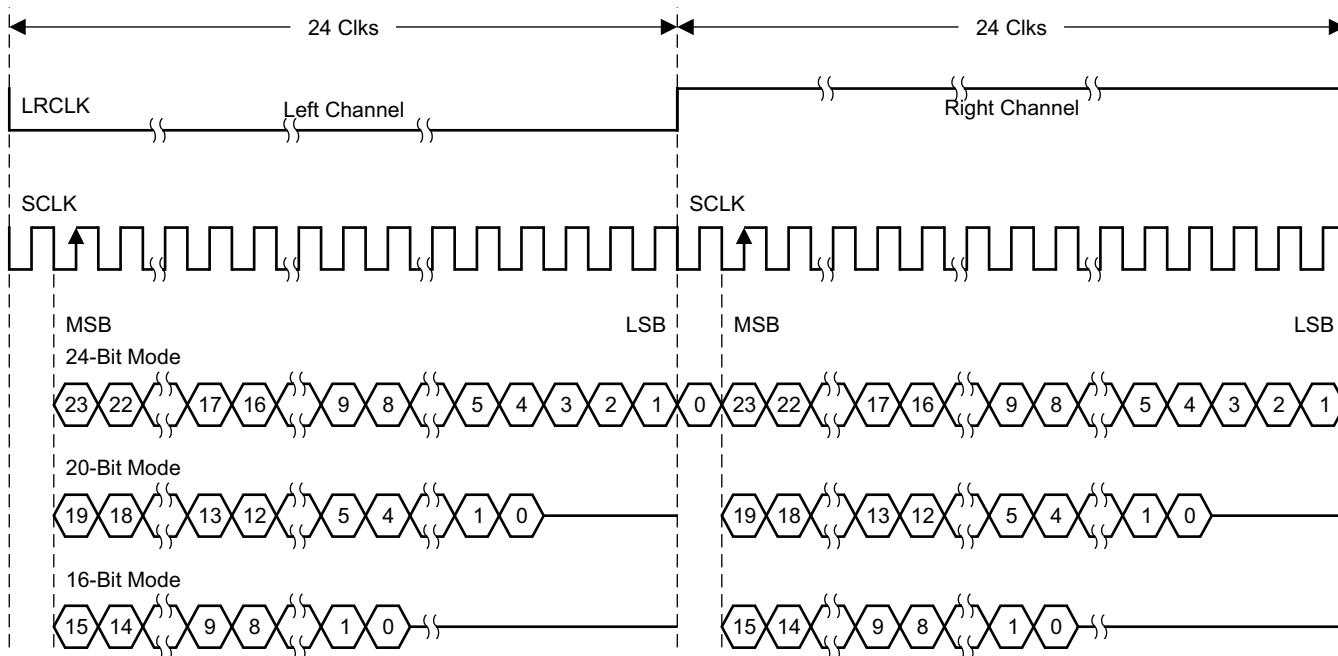

T0092-01

NOTE: All data presented in 2s-complement form with MSB first.

Figure 33. I²S 48-f_s Format

2-Channel I²S (Philips Format) Stereo Input

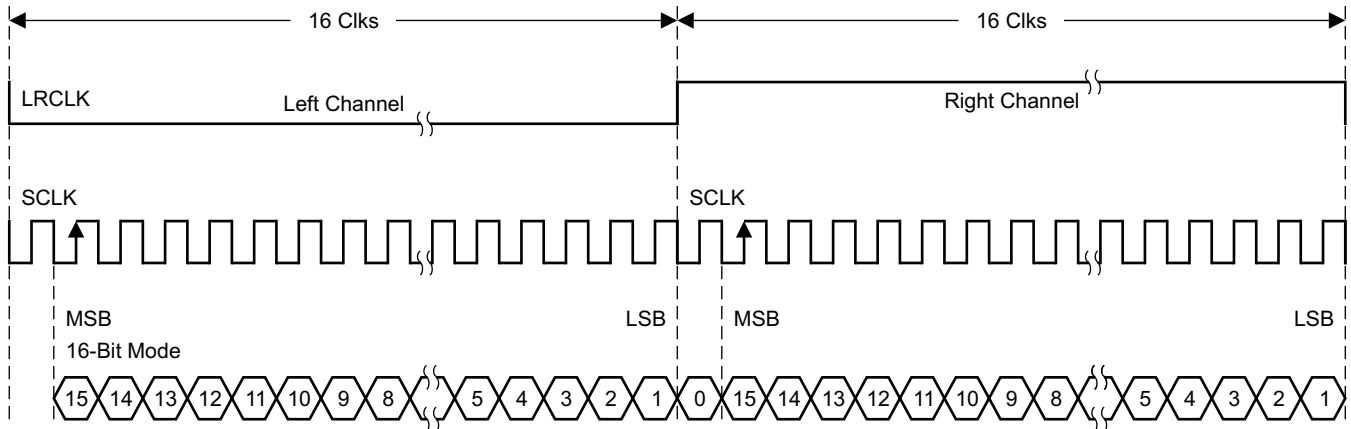

T0266-01

NOTE: All data presented in 2s-complement form with MSB first.

Figure 34. I²S 32-f_s Format

Left-Justified

Left-justified (LJ) timing uses LRCLK to define when the data being transmitted is for the left channel and when it is for the right channel. LRCLK is high for the left channel and low for the right channel. A bit clock running at 32, 48, or 64 × f_s is used to clock in the data. The first bit of data appears on the data lines at the same time LRCLK toggles. The data is written MSB-first and is valid on the rising edge of the bit clock. The DAP masks unused trailing data bit positions.

2-Channel Left-Justified Stereo Input

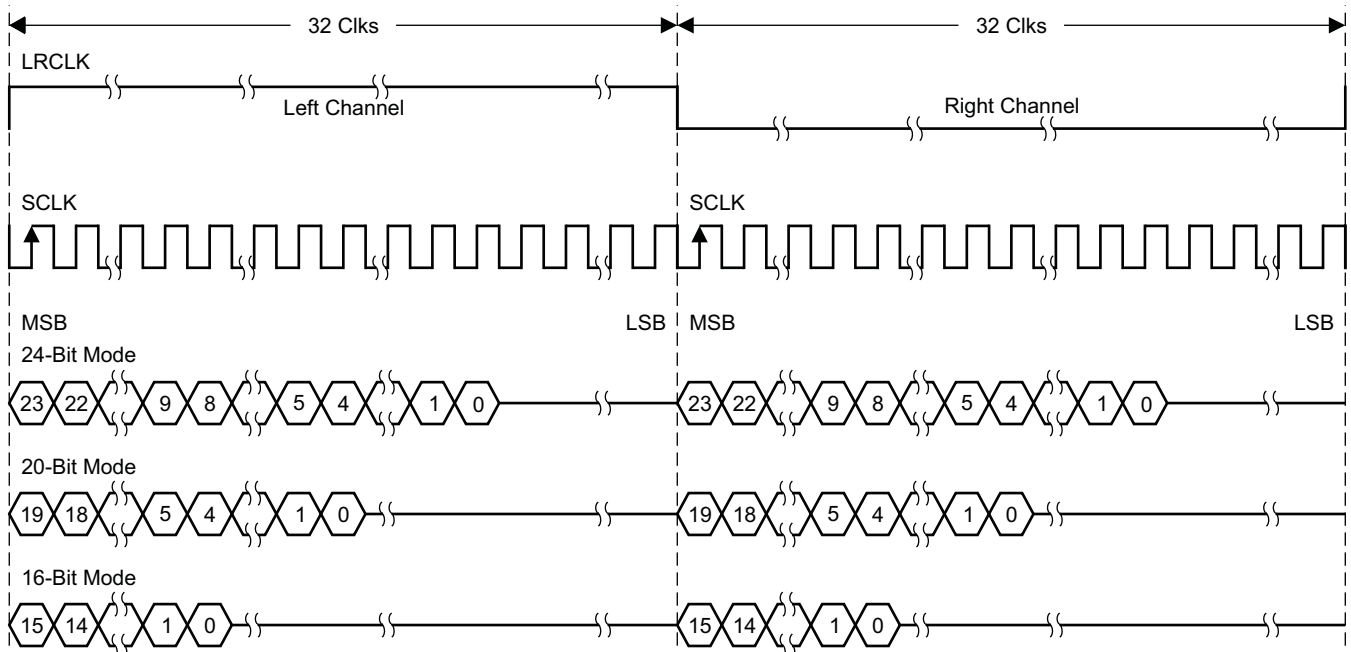

T0034-02

NOTE: All data presented in 2s-complement form with MSB first.

Figure 35. Left-Justified 64-f_s Format

2-Channel Left-Justified Stereo Input (24-Bit Transfer Word Size)

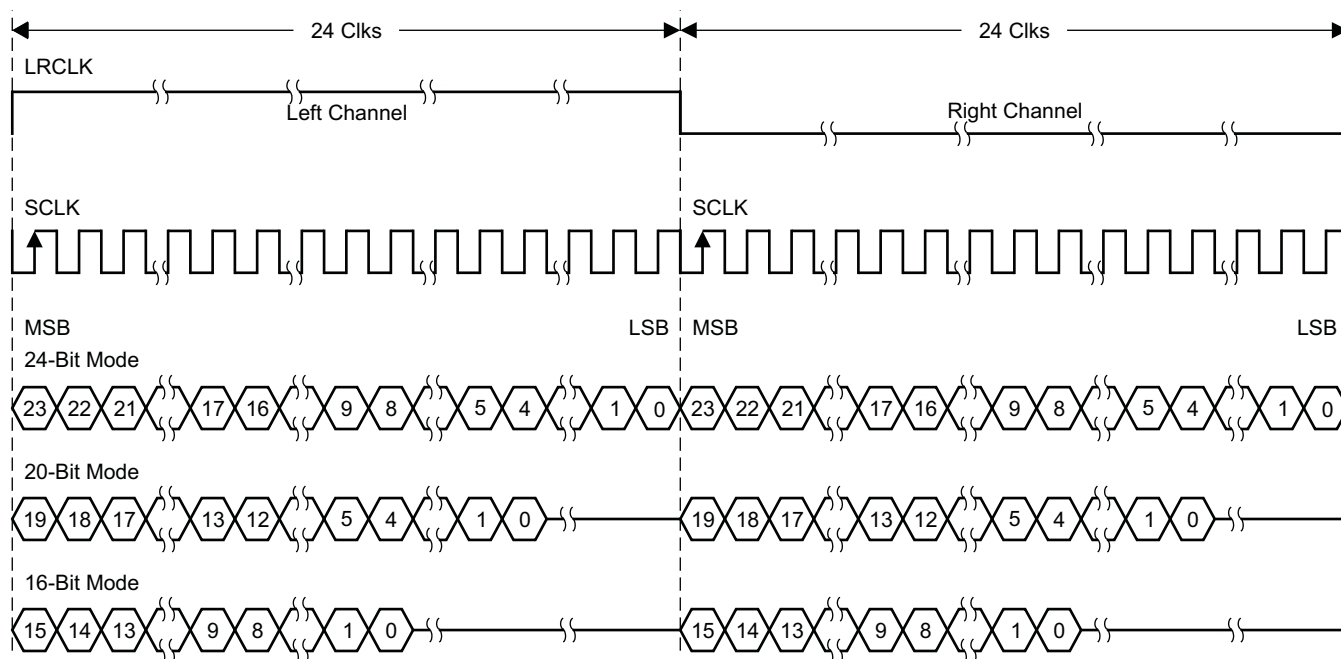

T0092-02

NOTE: All data presented in 2s-complement form with MSB first.

Figure 36. Left-Justified 48-f_s Format

2-Channel Left-Justified Stereo Input

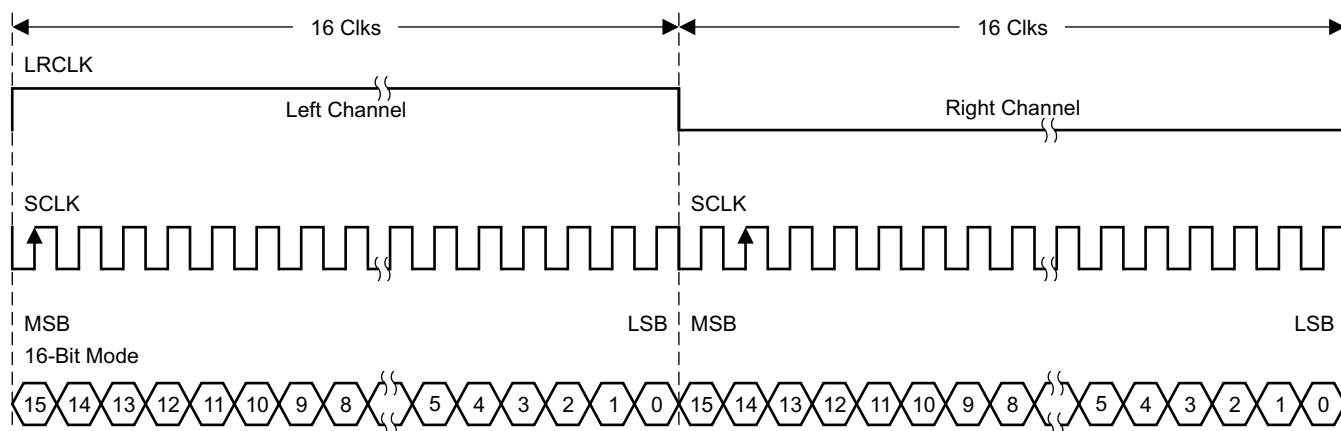

T0266-02

NOTE: All data presented in 2s-complement form with MSB first.

Figure 37. Left-Justified 32-f_s Format

Right-Justified

Right-justified (RJ) timing uses LRCLK to define when the data being transmitted is for the left channel and when

it is for the right channel. LRCLK is high for the left channel and low for the right channel. A bit clock running at $32, 48, \text{ or } 64 \times f_s$ is used to clock in the data. The first bit of data appears on the data 8 bit-clock periods (for 24-bit data) after LRCLK toggles. In RJ mode, the LSB of data is always clocked by the last bit clock before LRCLK transitions. The data is written MSB-first and is valid on the rising edge of bit clock. The DAP masks unused leading data bit positions.

2-Channel Right-Justified (Sony Format) Stereo Input

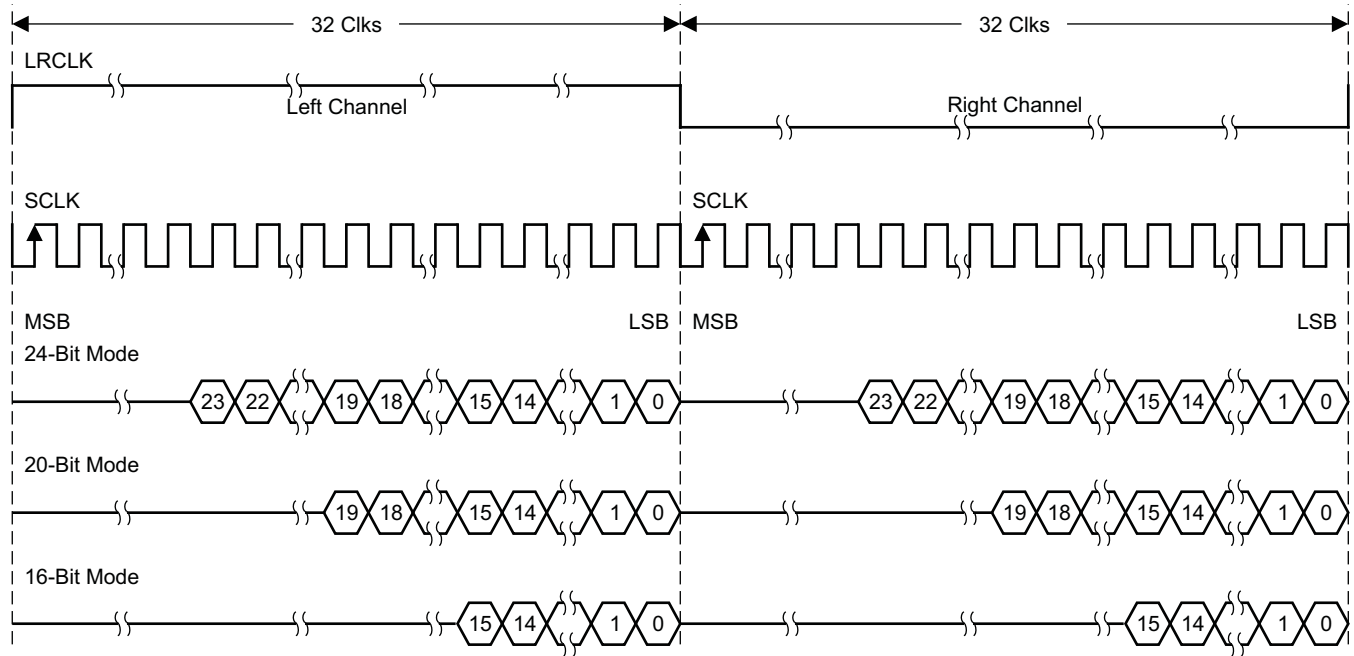

T0034-03

Figure 38. Right-Justified $64\text{-}f_s$ Format

2-Channel Right-Justified Stereo Input (24-Bit Transfer Word Size)

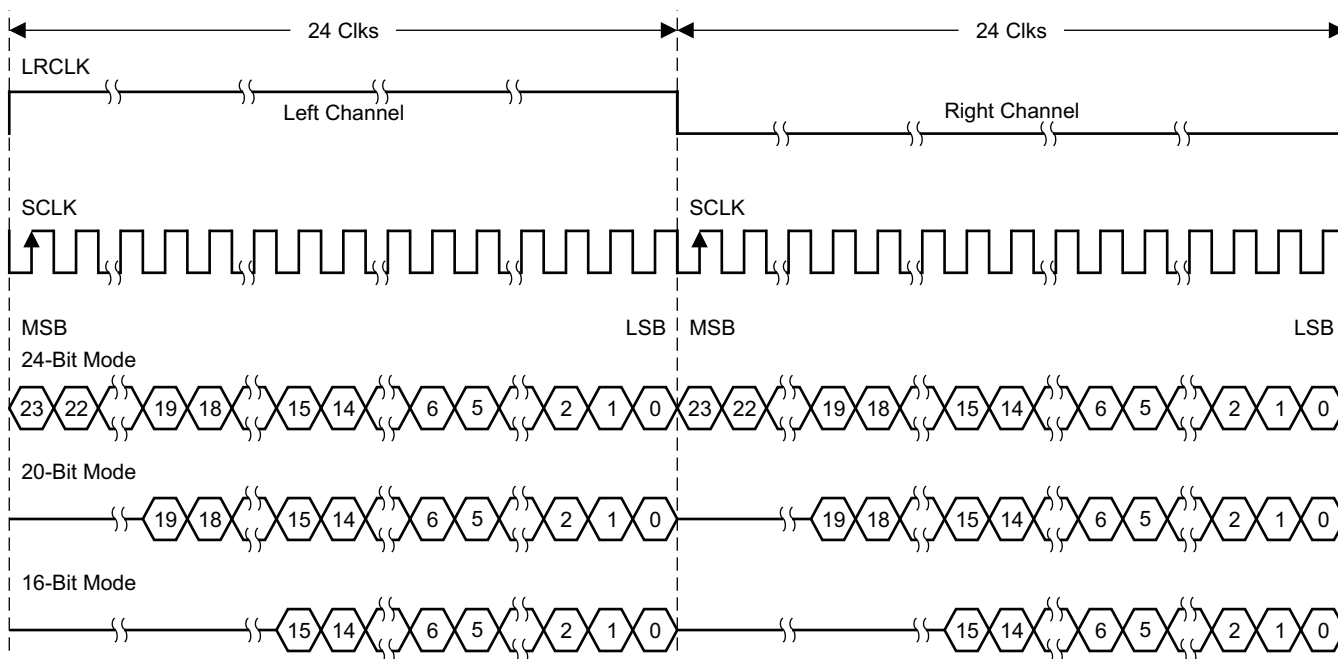

T0092-03

Figure 39. Right-Justified 48-f_s Format

2-Channel Right-Justified (Sony Format) Stereo Input

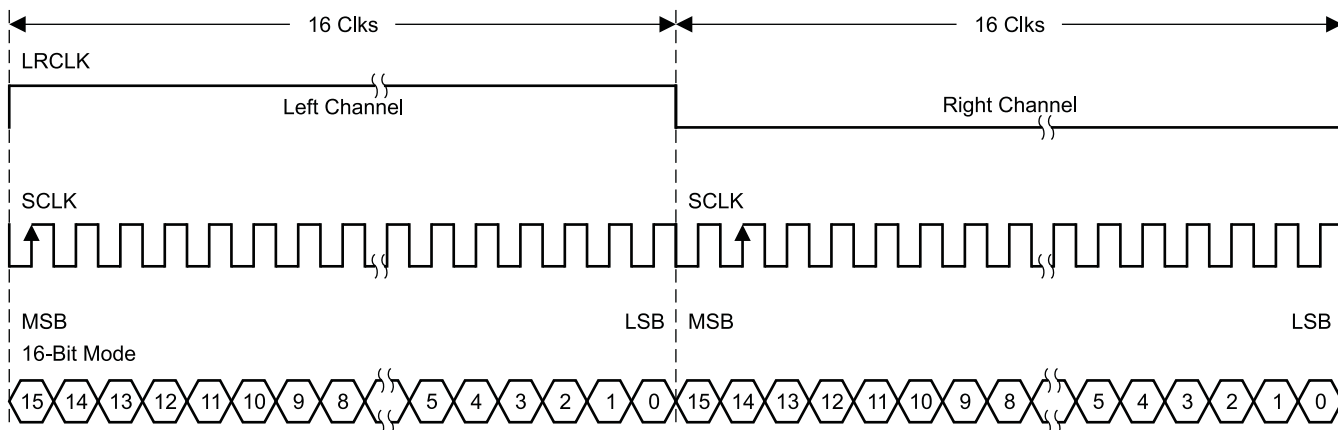

T0266-03

Figure 40. Right-Justified 32-f_s Format

I²C SERIAL CONTROL INTERFACE

The TAS5713 DAP has a bidirectional I²C interface that is compatible with the Inter IC (I²C) bus protocol and supports both 100-kHz and 400-kHz data transfer rates for single- and multiple-byte write and read operations. This is a slave-only device that does not support a multimaster bus environment or wait-state insertion. The control interface is used to program the registers of the device and to read device status.

The DAP supports the standard-mode I²C bus operation (100 kHz maximum) and the fast I²C bus operation (400 kHz maximum). The DAP performs all I²C operations without I²C wait cycles.

General I²C Operation

The I²C bus employs two signals, SDA (data) and SCL (clock), to communicate between integrated circuits in a system. Data is transferred on the bus serially, one bit at a time. The address and data can be transferred in byte (8-bit) format, with the most-significant bit (MSB) transferred first. In addition, each byte transferred on the bus is acknowledged by the receiving device with an acknowledge bit. Each transfer operation begins with the master device driving a start condition on the bus and ends with the master device driving a stop condition on the bus. The bus uses transitions on the data pin (SDA) while the clock is high to indicate start and stop conditions. A high-to-low transition on SDA indicates a start and a low-to-high transition indicates a stop. Normal data-bit transitions must occur within the low time of the clock period. These conditions are shown in Figure 41. The master generates the 7-bit slave address and the read/write (R/W) bit to open communication with another device and then waits for an acknowledge condition. The TAS5713 holds SDA low during the acknowledge clock period to indicate an acknowledgment. When this occurs, the master transmits the next byte of the sequence. Each device is addressed by a unique 7-bit slave address plus R/W bit (1 byte). All compatible devices share the same signals via a bidirectional bus using a wired-AND connection. An external pullup resistor must be used for the SDA and SCL signals to set the high level for the bus.

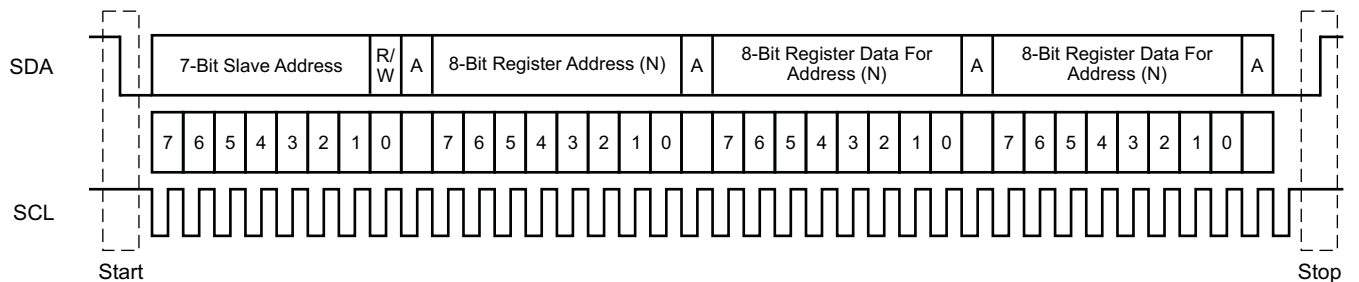

T0035-01

Figure 41. Typical I²C Sequence

There is no limit on the number of bytes that can be transmitted between start and stop conditions. When the last word transfers, the master generates a stop condition to release the bus. A generic data transfer sequence is shown in Figure 41.

The 7-bit address for the TAS5713 is 0011 011 (0x36) or 0011 010 (0x34) based on the polarity of the A_SEL_FAULT pin.

The TAS5713 address can be changed from 0x36 to 0x38 by writing 0x38 to device address register 0xF9.

Single- and Multiple-Byte Transfers

The serial control interface supports both single-byte and multiple-byte read/write operations for subaddresses 0x00 to 0x1F. However, for the subaddresses 0x20 to 0xFF, the serial control interface supports only multiple-byte read/write operations (in multiples of 4 bytes).

During multiple-byte read operations, the DAP responds with data, a byte at a time, starting at the subaddress assigned, as long as the master device continues to respond with acknowledges. If a particular subaddress does not contain 32 bits, the unused bits are read as logic 0.

During multiple-byte write operations, the DAP compares the number of bytes transmitted to the number of bytes that are required for each specific subaddress. For example, if a write command is received for a biquad subaddress, the DAP must receive five 32-bit words. If fewer than five 32-bit data words have been received when a stop command (or another start command) is received, the received data is discarded.

Supplying a subaddress for each subaddress transaction is referred to as random I²C addressing. The TAS5713 also supports sequential I²C addressing. For write transactions, if a subaddress is issued followed by data for that subaddress and the 15 subaddresses that follow, a sequential I²C write transaction has taken place, and the data for all 16 subaddresses is successfully received by the TAS5713. For I²C sequential-write transactions, the subaddress then serves as the start address, and the amount of data subsequently transmitted, before a stop or start is transmitted, determines how many subaddresses are written. As was true for random addressing, sequential addressing requires that a complete set of data be transmitted. If only a partial set of data is written to the last subaddress, the data for the last subaddress is discarded. However, all other data written is accepted; only the incomplete data is discarded.

Single-Byte Write

As shown in Figure 42, a single-byte data-write transfer begins with the master device transmitting a start condition followed by the I²C device address and the read/write bit. The read/write bit determines the direction of the data transfer. For a data-write transfer, the read/write bit is a 0. After receiving the correct I²C device address and the read/write bit, the DAP responds with an acknowledge bit. Next, the master transmits the address byte or bytes corresponding to the TAS5713 internal memory address being accessed. After receiving the address byte, the TAS5713 again responds with an acknowledge bit. Next, the master device transmits the data byte to be written to the memory address being accessed. After receiving the data byte, the TAS5713 again responds with an acknowledge bit. Finally, the master device transmits a stop condition to complete the single-byte data-write transfer.

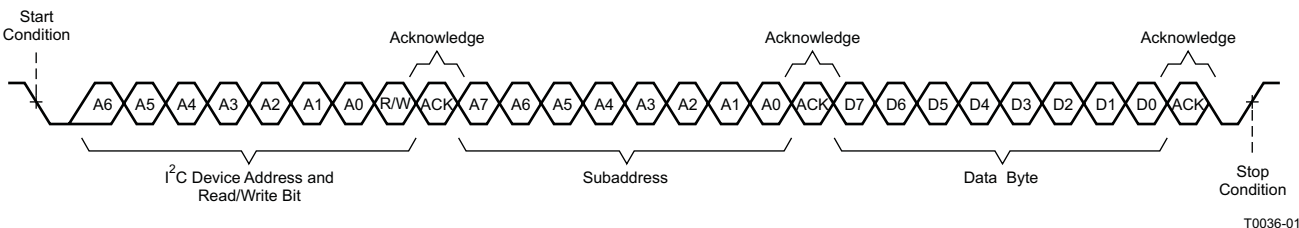

Figure 42. Single-Byte Write Transfer

Multiple-Byte Write

A multiple-byte data-write transfer is identical to a single-byte data-write transfer except that multiple data bytes are transmitted by the master device to the DAP as shown in Figure 43. After receiving each data byte, the TAS5713 responds with an acknowledge bit.

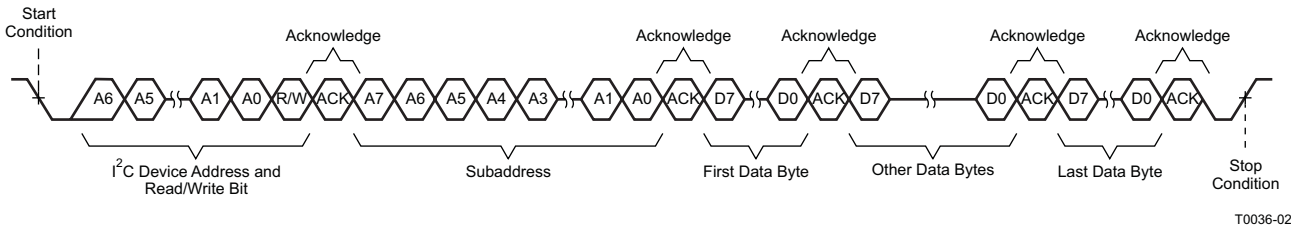

Figure 43. Multiple-Byte Write Transfer

Single-Byte Read

As shown in [Figure 44](#), a single-byte data-read transfer begins with the master device transmitting a start condition, followed by the I²C device address and the read/write bit. For the data read transfer, both a write followed by a read are actually done. Initially, a write is done to transfer the address byte or bytes of the internal memory address to be read. As a result, the read/write bit becomes a 0. After receiving the TAS5713 address and the read/write bit, TAS5713 responds with an acknowledge bit. In addition, after sending the internal memory address byte or bytes, the master device transmits another start condition followed by the TAS5713 address and the read/write bit again. This time, the read/write bit becomes a 1, indicating a read transfer. After receiving the address and the read/write bit, the TAS5713 again responds with an acknowledge bit. Next, the TAS5713 transmits the data byte from the memory address being read. After receiving the data byte, the master device transmits a not-acknowledge followed by a stop condition to complete the single-byte data-read transfer.

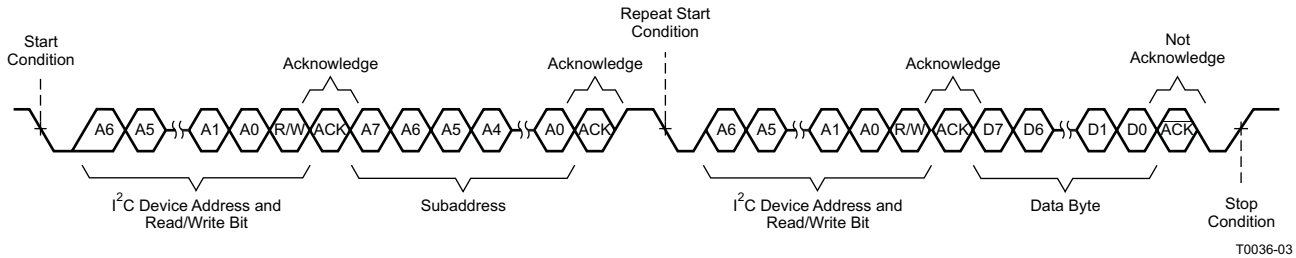

Figure 44. Single-Byte Read Transfer

Multiple-Byte Read

A multiple-byte data-read transfer is identical to a single-byte data-read transfer except that multiple data bytes are transmitted by the TAS5713 to the master device as shown in [Figure 45](#). Except for the last data byte, the master device responds with an acknowledge bit after receiving each data byte.

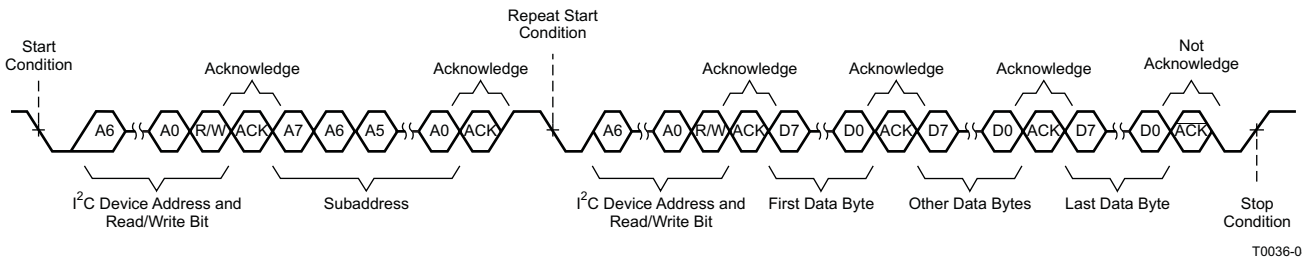
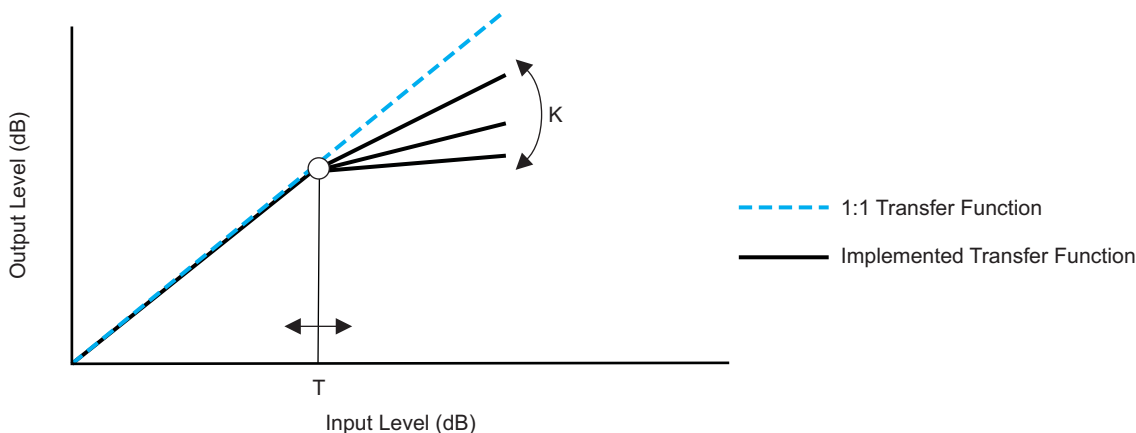

Figure 45. Multiple-Byte Read Transfer

Dynamic Range Control (DRC)

The DRC scheme has a single threshold, offset, and slope (all programmable). There is one ganged DRC for the high-band left/right channels and one DRC for the low-band left/right channels.

The DRC input/output diagram is shown in Figure 46.



M0091-03

Professional-quality dynamic range compression automatically adjusts volume to flatten volume level.

- Each DRC has adjustable threshold levels
- Programmable energy, attack, and decay time constants
- *Transparent compression*: compressors can attack fast enough to avoid apparent clipping before engaging, and decay times can be set slow enough to avoid pumping.

Figure 46. Dynamic Range Control

| | α, ω | T | $\alpha_a, \omega_a / \alpha_d, \omega_d$ |
|------|------------------|------|---|
| DRC1 | 0x3C | 0x3B | 0x40 |
| DRC2 | 0x3F | 0x3E | 0x43 |

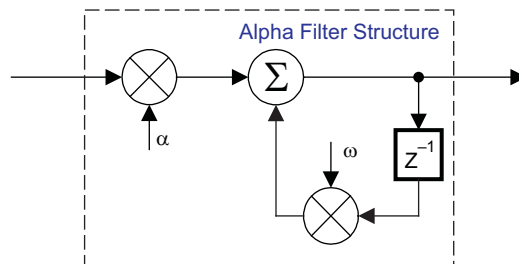

B0265-04

T = 9.23 format, all other DRC coefficients are 3.23 format

Figure 47. DRC Structure

BANK SWITCHING

The TAS5713 uses an approach called *bank switching* together with automatic sample-rate detection. All processing features that must be changed for different sample rates are stored internally in three banks. The user can program which sample rates map to each bank. By default, bank 1 is used in the 32-kHz mode, bank 2 is used in the 44.1/48-kHz mode, and bank 3 is used for all other rates. Combined with the clock-rate autodetection feature, bank switching allows the TAS5713 to detect automatically a change in the input sample rate and switch to the appropriate bank without any MCU intervention.

An external controller configures bankable locations (0x29–0x36, 0x3A–0x3F, and 0x58–0x5F) for all three banks during the initialization sequence.

If automatic bank switching is enabled (register 0x50, bits 2:0), then the TAS5713 automatically swaps the coefficients for subsequent sample-rate changes, avoiding the need for any external controller intervention for a sample-rate change.

By default, bits 2:0 have the value 000; indicating that bank switching is disabled. In that state, updates to bankable locations take immediate effect. A write to register 0x50 with bits 2:0 being 001, 010, or 011 brings the system into the coefficient-bank-update state *update bank1*, *update bank2*, or *update bank3*, respectively. Any subsequent write to bankable locations updates the coefficient banks stored outside the DAP. After updating all the three banks, the system controller should issue a write to register 0x50 with bits 2:0 being 100; this changes the system state to automatic bank switching mode. In automatic bank switching mode, the TAS5713 automatically swaps banks based on the sample rate.

Command sequences for updating DAP coefficients can be summarized as follows:

1. **Bank switching disabled (default):** DAP coefficient writes take immediate effect and are not influenced by subsequent sample-rate changes.
OR
Bank switching enabled:
 - (a) Update bank-1 mode: Write 001 to bits 2:0 of register 0x50. Load the 32-kHz coefficients.
 - (b) Update bank-2 mode: Write 010 to bits 2:0 of register 0x50. Load the 48-kHz coefficients.
 - (c) Update bank-3 mode: Write 011 to bits 2:0 of register 0x50. Load the other coefficients.
 - (d) Enable automatic bank switching by writing 100 to bits 2:0 of reg 0x50.

26-Bit 3.23 Number Format

All mixer gain coefficients are 26-bit coefficients using a 3.23 number format. Numbers formatted as 3.23 numbers means that there are 3 bits to the left of the binary point and 23 bits to the right of the binary point. This is shown in [Figure 48](#).

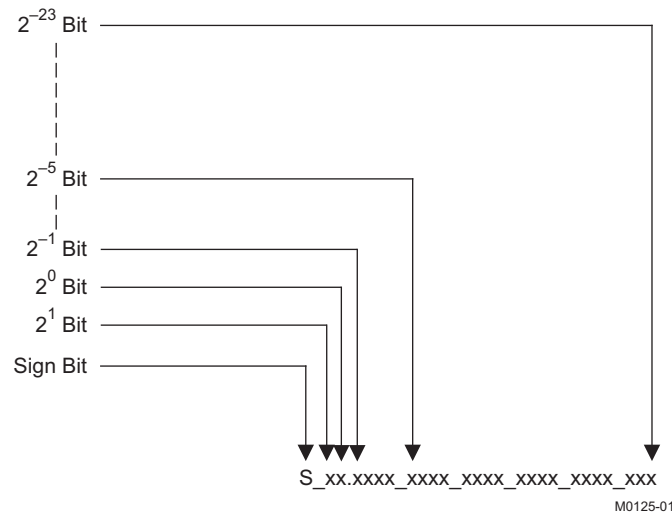

Figure 48. 3.23 Format

The decimal value of a 3.23 format number can be found by following the weighting shown in Figure 48. If the most significant bit is logic 0, the number is a positive number, and the weighting shown yields the correct number. If the most significant bit is a logic 1, then the number is a negative number. In this case every bit must be inverted, a 1 added to the result, and then the weighting shown in Figure 49 applied to obtain the magnitude of the negative number.

$$\begin{array}{c}
 2^1 \text{ Bit} \quad 2^0 \text{ Bit} \quad 2^{-1} \text{ Bit} \quad 2^{-4} \text{ Bit} \quad 2^{-23} \text{ Bit} \\
 \downarrow \quad \downarrow \quad \downarrow \quad \downarrow \quad \downarrow \\
 (1 \text{ or } 0) \times 2^1 + (1 \text{ or } 0) \times 2^0 + (1 \text{ or } 0) \times 2^{-1} + \dots (1 \text{ or } 0) \times 2^{-4} + \dots (1 \text{ or } 0) \times 2^{-23}
 \end{array}$$

M0126-01

Figure 49. Conversion Weighting Factors—3.23 Format to Floating Point

Gain coefficients, entered via the I²C bus, must be entered as 32-bit binary numbers. The format of the 32-bit number (4-byte or 8-digit hexadecimal number) is shown in Figure 50.

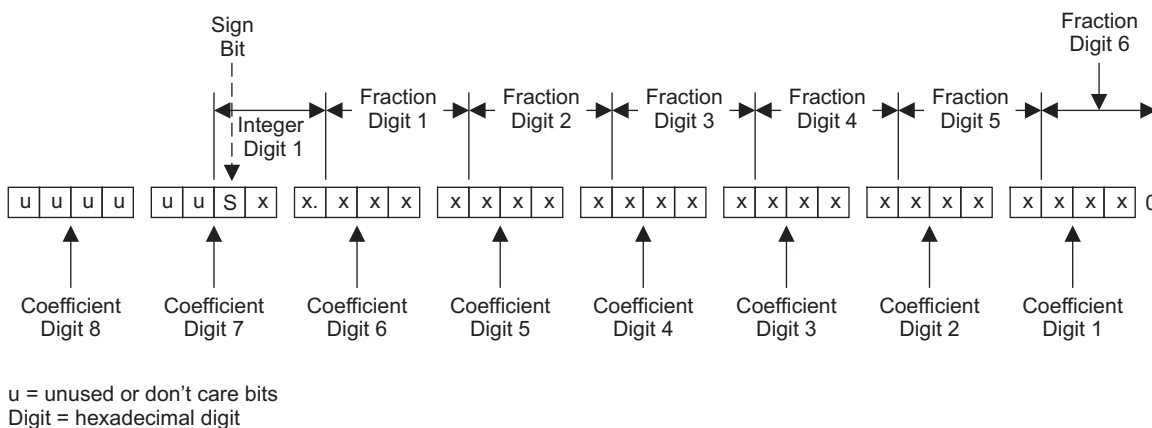

Figure 50. Alignment of 3.23 Coefficient in 32-Bit I²C Word

Table 2. Sample Calculation for 3.23 Format

| db | Linear | Decimal | Hex (3.23 Format) |
|----|-------------------|--------------------------|----------------------------|
| 0 | 1 | 8,388,608 | 80 0000 |
| 5 | 1.77 | 14,917,288 | 00E3 9EA8 |
| -5 | 0.56 | 4,717,260 | 0047 FACC |
| X | $L = 10^{(X/20)}$ | $D = 8,388,608 \times L$ | $H = \text{dec2hex}(D, 8)$ |

Table 3. Sample Calculation for 9.17 Format

| db | Linear | Decimal | Hex (9.17 Format) |
|----|-------------------|-----------------------|----------------------------|
| 0 | 1 | 131,072 | 2 0000 |
| 5 | 1.77 | 231,997 | 3 8A3D |
| -5 | 0.56 | 73,400 | 1 1EB8 |
| X | $L = 10^{(X/20)}$ | $D = 131072 \times L$ | $H = \text{dec2hex}(D, 8)$ |

Recommended Use Model

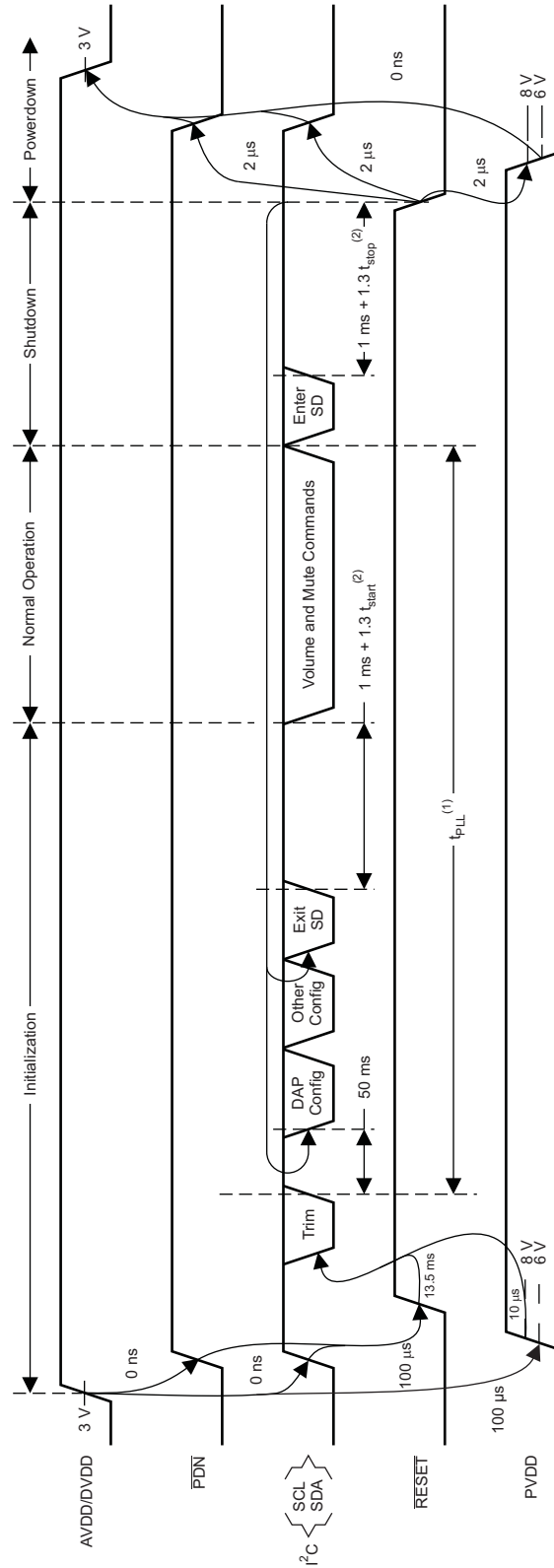

(1) t_{PLL} has to be greater than 240 ms + 1.3 t_{start}.
 This constraint only applies to the first trim command following AVDD/DVDD power-up.
 It does not apply to trim commands following subsequent resets.
 (2) t_{start}/t_{stop} = PWM start/stop time as defined in register 0X1A

T0419-06

Figure 51. Recommended Command Sequence

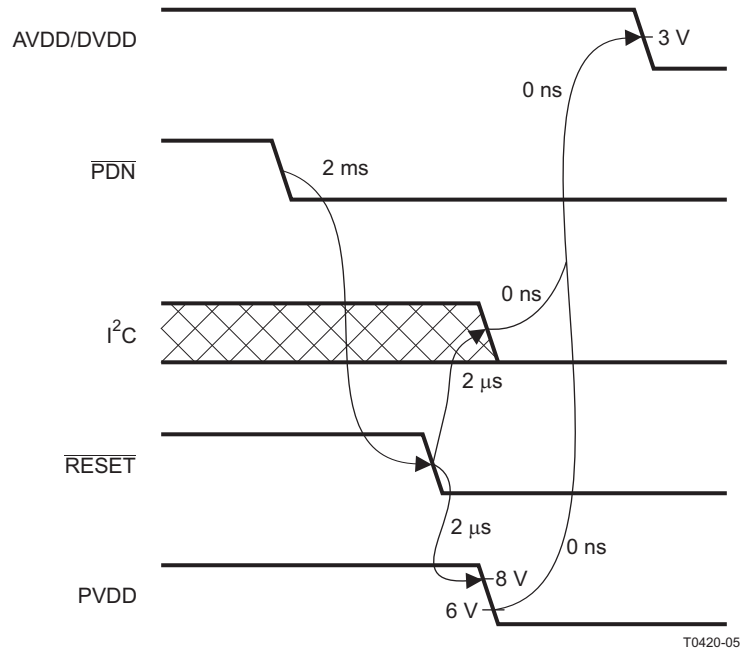
Figure 52. Power Loss Sequence

Initialization Sequence

Use the following sequence to power-up and initialize the device:

1. Hold all digital inputs low and ramp up AVDD/DVDD to at least 3 V.
2. Initialize digital inputs and PVDD supply as follows:
 - Drive $\overline{\text{RESET}} = 0$, $\overline{\text{PDN}} = 1$, and other digital inputs to their desired state while ensuring that all are never more than 2.5 V above AVDD/DVDD. Wait at least 100 μs, drive $\overline{\text{RESET}} = 1$, and wait at least another 13.5 ms.
 - Ramp up PVDD to at least 8 V while ensuring that it remains below 6 V for at least 100 μs after AVDD/DVDD reaches 3 V. Then wait at least another 10 μs.
3. Trim oscillator (write 0x00 to register 0x1B) and wait at least 50 ms.
4. Configure the DAP via I²C (see Users's Guide for typical values).
5. Configure remaining registers.
6. Exit shutdown (sequence defined below).

Normal Operation

The following are the only events supported during normal operation:

1. Writes to master/channel volume registers.
2. Writes to soft mute register.
3. Enter and exit shutdown (sequence defined below).

Note: Event 3 is not supported for $240 \text{ ms} + 1.3 \times t_{\text{start}}$ after trim following AVDD/DVDD powerup ramp (where t_{start} is specified by register 0x1A).

Shutdown Sequence

Enter:

1. Write 0x40 to register 0x05.
2. Wait at least $1 \text{ ms} + 1.3 \times t_{\text{stop}}$ (where t_{stop} is specified by register 0x1A).
3. If desired, reconfigure by returning to step 4 of initialization sequence.

Exit:

1. Write 0x00 to register 0x05 (exit shutdown command may not be serviced for as much as 240 ms after trim following AVDD/DVDD powerup ramp).
2. Wait at least $1 \text{ ms} + 1.3 \times t_{\text{start}}$ (where t_{start} is specified by register 0x1A).
3. Proceed with normal operation.

Power-Down Sequence

Use the following sequence to powerdown the device and its supplies:

1. If time permits, enter shutdown (sequence defined above); else, in case of sudden power loss, assert $\overline{\text{PDN}} = 0$ and wait at least 2 ms.
2. Assert $\overline{\text{RESET}} = 0$.
3. Drive digital inputs low and ramp down PVDD supply as follows:
 - Drive all digital inputs low after $\overline{\text{RESET}}$ has been low for at least 2 μs .
 - Ramp down PVDD while ensuring that it remains above 8 V until $\overline{\text{RESET}}$ has been low for at least 2 μs .
4. Ramp down AVDD/DVDD while ensuring that it remains above 3 V until PVDD is below 6 V and that it is never more than 2.5 V below the digital inputs.

Table 4. Serial Control Interface Register Summary

| SUBADDRESS | REGISTER NAME | NO. OF BYTES | CONTENTS | INITIALIZATION VALUE |
|------------|--------------------------------|--------------|---|----------------------|
| | | | A u indicates unused bits. | |
| 0x00 | Clock control register | 1 | Description shown in subsequent section | 0x6C |
| 0x01 | Device ID register | 1 | Description shown in subsequent section | 0x43 |
| 0x02 | Error status register | 1 | Description shown in subsequent section | 0x00 |
| 0x03 | System control register 1 | 1 | Description shown in subsequent section | 0xA0 |
| 0x04 | Serial data interface register | 1 | Description shown in subsequent section | 0x05 |
| 0x05 | System control register 2 | 1 | Description shown in subsequent section | 0x40 |
| 0x06 | Soft mute register | 1 | Description shown in subsequent section | 0x00 |
| 0x07 | Master volume | 1 | Description shown in subsequent section | 0xFF (mute) |
| 0x08 | Channel 1 vol | 1 | Description shown in subsequent section | 0x30 (0 dB) |
| 0x09 | Channel 2 vol | 1 | Description shown in subsequent section | 0x30 (0 dB) |
| 0x0A | Channel 3 vol | 1 | Description shown in subsequent section | 0x30 (0 dB) |
| 0x0B–0x0D | | 1 | Reserved ⁽¹⁾ | |
| 0x0E | Volume configuration register | 1 | Description shown in subsequent section | 0x91 |
| 0x0F | | 1 | Reserved ⁽¹⁾ | |
| 0x10 | Modulation limit register | 1 | Description shown in subsequent section | 0x02 |
| 0x11 | IC delay channel 1 | 1 | Description shown in subsequent section | 0xAC |
| 0x12 | IC delay channel 2 | 1 | Description shown in subsequent section | 0x54 |
| 0x13 | IC delay channel 3 | 1 | Description shown in subsequent section | 0xAC |
| 0x14 | IC delay channel 4 | 1 | Description shown in subsequent section | 0x54 |
| 0x15–0x19 | | 1 | Reserved ⁽¹⁾ | |
| 0x1A | Start/stop period register | 1 | | 0x0F |
| 0x1B | Oscillator trim register | 1 | | 0x82 |
| 0x1C | BKND_ERR register | 1 | | 0x02 |
| 0x1D–0x1F | | 1 | Reserved ⁽¹⁾ | |
| 0x20 | Input MUX register | 4 | Description shown in subsequent section | 0x0001 7772 |
| 0x21 | Ch 4 source select register | 4 | Description shown in subsequent section | 0x0000 4303 |
| 0x22–0x24 | | 4 | Reserved ⁽¹⁾ | |
| 0x25 | PWM MUX register | 4 | Description shown in subsequent section | 0x0102 1345 |
| 0x26–0x28 | | 4 | Reserved ⁽¹⁾ | |
| 0x29 | ch1_bq[0] | 20 | u[31:26], b0[25:0] | 0x0080 0000 |
| | | | u[31:26], b1[25:0] | 0x0000 0000 |
| | | | u[31:26], b2[25:0] | 0x0000 0000 |
| | | | u[31:26], a1[25:0] | 0x0000 0000 |
| | | | u[31:26], a2[25:0] | 0x0000 0000 |
| 0x2A | ch1_bq[1] | 20 | u[31:26], b0[25:0] | 0x0080 0000 |
| | | | u[31:26], b1[25:0] | 0x0000 0000 |
| | | | u[31:26], b2[25:0] | 0x0000 0000 |
| | | | u[31:26], a1[25:0] | 0x0000 0000 |
| | | | u[31:26], a2[25:0] | 0x0000 0000 |

(1) Reserved registers should not be accessed.

Table 4. Serial Control Interface Register Summary (continued)

| SUBADDRESS | REGISTER NAME | NO. OF BYTES | CONTENTS | INITIALIZATION VALUE |
|------------|---------------|--------------|--------------------|----------------------|
| 0x2B | ch1_bq[2] | 20 | u[31:26], b0[25:0] | 0x0080 0000 |
| | | | u[31:26], b1[25:0] | 0x0000 0000 |
| | | | u[31:26], b2[25:0] | 0x0000 0000 |
| | | | u[31:26], a1[25:0] | 0x0000 0000 |
| | | | u[31:26], a2[25:0] | 0x0000 0000 |
| 0x2C | ch1_bq[3] | 20 | u[31:26], b0[25:0] | 0x0080 0000 |
| | | | u[31:26], b1[25:0] | 0x0000 0000 |
| | | | u[31:26], b2[25:0] | 0x0000 0000 |
| | | | u[31:26], a1[25:0] | 0x0000 0000 |
| | | | u[31:26], a2[25:0] | 0x0000 0000 |
| 0x2D | ch1_bq[4] | 20 | u[31:26], b0[25:0] | 0x0080 0000 |
| | | | u[31:26], b1[25:0] | 0x0000 0000 |
| | | | u[31:26], b2[25:0] | 0x0000 0000 |
| | | | u[31:26], a1[25:0] | 0x0000 0000 |
| | | | u[31:26], a2[25:0] | 0x0000 0000 |
| 0x2E | ch1_bq[5] | 20 | u[31:26], b0[25:0] | 0x0080 0000 |
| | | | u[31:26], b1[25:0] | 0x0000 0000 |
| | | | u[31:26], b2[25:0] | 0x0000 0000 |
| | | | u[31:26], a1[25:0] | 0x0000 0000 |
| | | | u[31:26], a2[25:0] | 0x0000 0000 |
| 0x2F | ch1_bq[6] | 20 | u[31:26], b0[25:0] | 0x0080 0000 |
| | | | u[31:26], b1[25:0] | 0x0000 0000 |
| | | | u[31:26], b2[25:0] | 0x0000 0000 |
| | | | u[31:26], a1[25:0] | 0x0000 0000 |
| | | | u[31:26], a2[25:0] | 0x0000 0000 |
| 0x30 | ch2_bq[0] | 20 | u[31:26], b0[25:0] | 0x0080 0000 |
| | | | u[31:26], b1[25:0] | 0x0000 0000 |
| | | | u[31:26], b2[25:0] | 0x0000 0000 |
| | | | u[31:26], a1[25:0] | 0x0000 0000 |
| | | | u[31:26], a2[25:0] | 0x0000 0000 |
| 0x31 | ch2_bq[1] | 20 | u[31:26], b0[25:0] | 0x0080 0000 |
| | | | u[31:26], b1[25:0] | 0x0000 0000 |
| | | | u[31:26], b2[25:0] | 0x0000 0000 |
| | | | u[31:26], a1[25:0] | 0x0000 0000 |
| | | | u[31:26], a2[25:0] | 0x0000 0000 |
| 0x32 | ch2_bq[2] | 20 | u[31:26], b0[25:0] | 0x0080 0000 |
| | | | u[31:26], b1[25:0] | 0x0000 0000 |
| | | | u[31:26], b2[25:0] | 0x0000 0000 |
| | | | u[31:26], a1[25:0] | 0x0000 0000 |
| | | | u[31:26], a2[25:0] | 0x0000 0000 |
| 0x33 | ch2_bq[3] | 20 | u[31:26], b0[25:0] | 0x0080 0000 |
| | | | u[31:26], b1[25:0] | 0x0000 0000 |
| | | | u[31:26], b2[25:0] | 0x0000 0000 |
| | | | u[31:26], a1[25:0] | 0x0000 0000 |
| | | | u[31:26], a2[25:0] | 0x0000 0000 |

Table 4. Serial Control Interface Register Summary (continued)

| SUBADDRESS | REGISTER NAME | NO. OF BYTES | CONTENTS | INITIALIZATION VALUE |
|------------|-----------------------------|--------------|--|----------------------|
| 0x34 | ch2_bq[4] | 20 | u[31:26], b0[25:0] | 0x0080 0000 |
| | | | u[31:26], b1[25:0] | 0x0000 0000 |
| | | | u[31:26], b2[25:0] | 0x0000 0000 |
| | | | u[31:26], a1[25:0] | 0x0000 0000 |
| | | | u[31:26], a2[25:0] | 0x0000 0000 |
| 0x35 | ch2_bq[5] | 20 | u[31:26], b0[25:0] | 0x0080 0000 |
| | | | u[31:26], b1[25:0] | 0x0000 0000 |
| | | | u[31:26], b2[25:0] | 0x0000 0000 |
| | | | u[31:26], a1[25:0] | 0x0000 0000 |
| | | | u[31:26], a2[25:0] | 0x0000 0000 |
| 0x36 | ch2_bq[6] | 20 | u[31:26], b0[25:0] | 0x0080 0000 |
| | | | u[31:26], b1[25:0] | 0x0000 0000 |
| | | | u[31:26], b2[25:0] | 0x0000 0000 |
| | | | u[31:26], a1[25:0] | 0x0000 0000 |
| | | | u[31:26], a2[25:0] | 0x0000 0000 |
| 0x36–0x3A | | 4 | Reserved ⁽²⁾ | |
| 0x3B | DRC1 softening filter alpha | 8 | u[31:26], ae[25:0] | 0x0008 0000 |
| | DRC1 softening filter omega | | u[31:26], oe[25:0] | 0x0078 0000 |
| 0x3C | DRC1 attack rate | 8 | | 0x0000 0100 |
| | DRC1 release rate | | | 0xFFFF FF00 |
| 0x3D | | 8 | Reserved ⁽²⁾ | 0x0080 0000 |
| 0x3E | DRC2 softening filter alpha | 8 | u[31:26], ae[25:0] | 0x0008 0000 |
| | DRC2 softening filter omega | | u[31:26], oe[25:0] | 0xFFFF 8000 |
| 0x3F | DRC2 attack rate | 8 | u[31:26], at[25:0] | 0x0008 0000 |
| | DRC2 release rate | | u[31:26], rt[25:0] | 0xFFFF 8000 |
| 0x40 | DRC1 attack threshold | 8 | T1[31:0] (9.23 format) | 0x0800 0000 |
| | DRC1 release threshold | | T1'[31:0] | 0x07FF FFFF |
| 0x41–0x42 | | 4 | Reserved ⁽²⁾ | |
| 0x43 | DRC2 attack threshold | 8 | T2[31:0] (9.23 format) | 0x0080 0000 |
| | DRC2 decay threshold | | T2'[31:0] | 0x0000 0000 |
| 0x44–0x45 | | 4 | Reserved ⁽²⁾ | |
| 0x46 | DRC control | 4 | Description shown in subsequent section | 0x0000 0000 |
| 0x47–0x4F | | 4 | Reserved ⁽²⁾ | |
| 0x50 | Bank switch control | 4 | Description shown in subsequent section | 0x0F70 8000 |
| 0x51 | Ch 1 output mixer | 8 | Ch 1 output mix1[1] | 0x0080 0000 |
| | | | Ch 1 output mix1[0] | 0x0000 0000 |
| 0x52 | Ch 2 output mixer | 8 | Ch 2 output mix2[1] | 0x0080 0000 |
| | | | Ch 2 output mix2[0] | 0x0000 0000 |
| 0x53 | Ch 1 input mixers | 16 | Channel-1 input mixers can be accessed using I ² C subaddresses 0x70–0x73 using 4-byte access | |
| 0x54 | Ch 2 input mixers | 16 | Channel-2 input mixers can be accessed using I ² C subaddresses 0x74–0x77 using 4-byte access | |
| 0x56 | Output post-scale | 4 | u[31:26], post[25:0] | 0x0080 0000 |
| 0x57 | Output pre-scale | 4 | u[31:26], pre[25:0] (9.17 format) | 0x0002 0000 |

(2) Reserved registers should not be accessed.

Table 4. Serial Control Interface Register Summary (continued)

| SUBADDRESS | REGISTER NAME | NO. OF BYTES | CONTENTS | INITIALIZATION VALUE |
|------------|-------------------------|--------------|-----------------------------|----------------------|
| 0x58 | ch1 BQ[7] | 20 | u[31:26], b0[25:0] | 0x0080 0000 |
| | | | u[31:26], b1[25:0] | 0x0000 0000 |
| | | | u[31:26], b2[25:0] | 0x0000 0000 |
| | | | u[31:26], a1[25:0] | 0x0000 0000 |
| | | | u[31:26], a2[25:0] | 0x0000 0000 |
| 0x59 | ch1 BQ[8] | 20 | u[31:26], b0[25:0] | 0x0080 0000 |
| | | | u[31:26], b1[25:0] | 0x0000 0000 |
| | | | u[31:26], b2[25:0] | 0x0000 0000 |
| | | | u[31:26], a1[25:0] | 0x0000 0000 |
| | | | u[31:26], a2[25:0] | 0x0000 0000 |
| 0x5A | ch4 BQ[0] | 20 | u[31:26], b0[25:0] | 0x0080 0000 |
| | | | u[31:26], b1[25:0] | 0x0000 0000 |
| | | | u[31:26], b2[25:0] | 0x0000 0000 |
| | | | u[31:26], a1[25:0] | 0x0000 0000 |
| | | | u[31:26], a2[25:0] | 0x0000 0000 |
| 0x5B | ch4 BQ[1] | 20 | u[31:26], b0[25:0] | 0x0080 0000 |
| | | | u[31:26], b1[25:0] | 0x0000 0000 |
| | | | u[31:26], b2[25:0] | 0x0000 0000 |
| | | | u[31:26], a1[25:0] | 0x0000 0000 |
| | | | u[31:26], a2[25:0] | 0x0000 0000 |
| 0x5C | ch2 BQ[7] | 20 | u[31:26], b0[25:0] | 0x0080 0000 |
| | | | u[31:26], b1[25:0] | 0x0000 0000 |
| | | | u[31:26], b2[25:0] | 0x0000 0000 |
| | | | u[31:26], a1[25:0] | 0x0000 0000 |
| | | | u[31:26], a2[25:0] | 0x0000 0000 |
| 0x5D | ch2 BQ[8] | 20 | u[31:26], b0[25:0] | 0x0080 0000 |
| | | | u[31:26], b1[25:0] | 0x0000 0000 |
| | | | u[31:26], b2[25:0] | 0x0000 0000 |
| | | | u[31:26], a1[25:0] | 0x0000 0000 |
| | | | u[31:26], a2[25:0] | 0x0000 0000 |
| 0x5E | ch3 BQ[0] | 20 | u[31:26], b0[25:0] | 0x0080 0000 |
| | | | u[31:26], b1[25:0] | 0x0000 0000 |
| | | | u[31:26], b2[25:0] | 0x0000 0000 |
| | | | u[31:26], a1[25:0] | 0x0000 0000 |
| | | | u[31:26], a2[25:0] | 0x0000 0000 |
| 0x5F | ch3 BQ[1] | 20 | u[31:26], b0[25:0] | 0x0080 0000 |
| | | | u[31:26], b1[25:0] | 0x0000 0000 |
| | | | u[31:26], b2[25:0] | 0x0000 0000 |
| | | | u[31:26], a1[25:0] | 0x0000 0000 |
| | | | u[31:26], a2[25:0] | 0x0000 0000 |
| 0x60–0x61 | | 4 | Reserved ⁽³⁾ | |
| 0x62 | IDF post scale | 4 | | 0x0000 0080 |
| 0x63–0x6F | | | Reserved ⁽³⁾ | 0x0000 0000 |
| 0x70 | ch1 inline mixer | 4 | u[31:26], in_mix1[25:0] | 0x0080 0000 |
| 0x71 | inline_DRC_en_mixer_ch1 | 4 | u[31:26], in_mixdrc_1[25:0] | 0x0000 0000 |
| 0x72 | ch1 right_channel mixer | 4 | u[31:26], right_mix1[25:0] | 0x0000 0000 |

(3) Reserved registers should not be accessed.

Table 4. Serial Control Interface Register Summary (continued)

| SUBADDRESS | REGISTER NAME | NO. OF BYTES | CONTENTS | INITIALIZATION VALUE |
|------------|-------------------------|--------------|--|----------------------|
| 0x73 | ch1 left_channel_mixer | 4 | u[31:26], left_mix_1[25:0] | 0x0080 0000 |
| 0x74 | ch2 inline mixer | 4 | u[31:26], in_mix2[25:0] | 0x0080 0000 |
| 0x75 | inline_DRC_en_mixer_ch2 | 4 | u[31:26], in_mixdrc_2[25:0] | 0x0000 0000 |
| 0x76 | ch2 left_channel mixer | 4 | u[31:26], left_mix1[25:0] | 0x0000 0000 |
| 0x77 | ch2 right_channel_mixer | 4 | u[31:26], right_mix_1[25:0] | 0x0080 0000 |
| 0x78–0xF7 | | | Reserved ⁽³⁾ | |
| 0xF8 | Update dev address key | 4 | Dev Id Update Key[31:0] (Key = 0xF9A5A5A5) | 0x0000 0000 |
| 0xF9 | Update dev address reg | 4 | u[31:8], New Dev Id[7:0] (New Dev Id = 0x38 for TAS5713) | 0x0000 0036 |
| 0xFA–0xFF | | 4 | Reserved ⁽³⁾ | 0x0000 0000 |

All DAP coefficients are 3.23 format unless specified otherwise.

Registers 0x3B through 0x46 should be altered only during the initialization phase.

CLOCK CONTROL REGISTER (0x00)

The clocks and data rates are automatically determined by the TAS5713. The clock control register contains the autodetected clock status. Bits D7–D5 reflect the sample rate. Bits D4–D2 reflect the MCLK frequency.

Table 5. Clock Control Register (0x00)

| D7 | D6 | D5 | D4 | D3 | D2 | D1 | D0 | FUNCTION |
|----------|----------|----------|----------|----------|----------|----------|----------|---|
| 0 | 0 | 0 | – | – | – | – | – | $f_S = 32\text{-kHz}$ sample rate |
| 0 | 0 | 1 | – | – | – | – | – | Reserved ⁽¹⁾ |
| 0 | 1 | 0 | – | – | – | – | – | Reserved ⁽¹⁾ |
| 0 | 1 | 1 | – | – | – | – | – | $f_S = 44.1/48\text{-kHz}$ sample rate ⁽²⁾ |
| 1 | 0 | 0 | – | – | – | – | – | $f_S = 16\text{-kHz}$ sample rate |
| 1 | 0 | 1 | – | – | – | – | – | $f_S = 22.05/24\text{-kHz}$ sample rate |
| 1 | 1 | 0 | – | – | – | – | – | $f_S = 8\text{-kHz}$ sample rate |
| 1 | 1 | 1 | – | – | – | – | – | $f_S = 11.025/12\text{-kHz}$ sample rate |
| – | – | – | 0 | 0 | 0 | – | – | MCLK frequency = $64 \times f_S$ ⁽³⁾ |
| – | – | – | 0 | 0 | 1 | – | – | MCLK frequency = $128 \times f_S$ ⁽³⁾ |
| – | – | – | 0 | 1 | 0 | – | – | MCLK frequency = $192 \times f_S$ ⁽⁴⁾ |
| – | – | – | 0 | 1 | 1 | – | – | MCLK frequency = $256 \times f_S$ ^{(2) (5)} |
| – | – | – | 1 | 0 | 0 | – | – | MCLK frequency = $384 \times f_S$ |
| – | – | – | 1 | 0 | 1 | – | – | MCLK frequency = $512 \times f_S$ |
| – | – | – | 1 | 1 | 0 | – | – | Reserved ⁽¹⁾ |
| – | – | – | 1 | 1 | 1 | – | – | Reserved ⁽¹⁾ |
| – | – | – | – | – | – | 0 | – | Reserved⁽¹⁾ |
| – | – | – | – | – | – | – | 0 | Reserved ⁽¹⁾ |

(1) Reserved registers should not be accessed.

(2) Default values are in **bold**.

(3) Only available for 44.1-kHz and 48-kHz rates

(4) Rate only available for 32/44.1/48-KHz sample rates

(5) Not available at 8 kHz

DEVICE ID REGISTER (0x01)

The device ID register contains the ID code for the firmware revision.

Table 6. General Status Register (0x01)

| D7 | D6 | D5 | D4 | D3 | D2 | D1 | D0 | FUNCTION |
|----|----|----|----|----|----|----|----|---------------------|
| 0 | 0 | 0 | 0 | 0 | 0 | 0 | 0 | Identification code |

ERROR STATUS REGISTER (0x02)

The error bits are sticky and are not cleared by the hardware. This means that the software must clear the register (write zeroes) and then read them to determine if they are persistent errors.

Error definitions:

- MCLK Error : MCLK frequency is changing. The number of MCLKs per LRCLK is changing.
- SCLK Error: The number of SCLKs per LRCLK is changing.
- LRCLK Error: LRCLK frequency is changing.
- Frame slip: LRCLK phase is drifting with respect to internal frame sync.

Table 7. Error Status Register (0x02)

| D7 | D6 | D5 | D4 | D3 | D2 | D1 | D0 | FUNCTION |
|----------|----------|----------|----------|----------|----------|----------|----------|--|
| 1 | - | - | - | - | - | - | - | MCLK error |
| - | 1 | - | - | - | - | - | - | PLL autolock error |
| - | - | 1 | - | - | - | - | - | SCLK error |
| - | - | - | 1 | - | - | - | - | LRCLK error |
| - | - | - | - | 1 | - | - | - | Frame slip |
| - | - | - | - | - | 1 | - | - | Clip indicator |
| - | - | - | - | - | - | 1 | - | Overcurrent, overtemperature, overvoltage, or undervoltage error |
| 0 | 0 | 0 | 0 | 0 | 0 | 0 | 0 | Reserved |
| 0 | 0 | 0 | 0 | 0 | 0 | 0 | 0 | No errors ⁽¹⁾ |

(1) Default values are in **bold**.

SYSTEM CONTROL REGISTER 1 (0x03)

System control register 1 has several functions:

Bit D7: If 0, the dc-blocking filter for each channel is disabled.

If 1, the dc-blocking filter (-3 dB cutoff <1 Hz) for each channel is enabled (default).

Bit D5: If 0, use soft unmute on recovery from a clock error. This is a slow recovery. Unmute takes the same time as the volume ramp defined in register 0x0E.

If 1, use hard unmute on recovery from clock error (default). This is a fast recovery, a single-step volume ramp.

Bits D1–D0: Select de-emphasis

Table 8. System Control Register 1 (0x03)

| D7 | D6 | D5 | D4 | D3 | D2 | D1 | D0 | FUNCTION |
|----------|----------|----------|----------|----------|----------|----------|----------|--|
| 0 | - | - | - | - | - | - | - | PWM high-pass (dc blocking) disabled |
| 1 | - | - | - | - | - | - | - | PWM high-pass (dc blocking) enabled ⁽¹⁾ |
| - | 0 | - | - | - | - | - | - | Reserved ⁽¹⁾ |
| - | - | 0 | - | - | - | - | - | Soft unmute on recovery from clock error |
| - | - | 1 | - | - | - | - | - | Hard unmute on recovery from clock error ⁽¹⁾ |
| - | - | - | 1 | - | - | - | - | Reserved ⁽¹⁾ |
| - | - | - | - | 0 | - | - | - | Reserved ⁽¹⁾ |
| - | - | - | - | - | 0 | - | - | Reserved ⁽¹⁾ |
| - | - | - | - | - | - | 0 | 0 | No de-emphasis ⁽¹⁾ |
| - | - | - | - | - | - | 0 | 1 | De-emphasis for $f_S = 32$ kHz |
| - | - | - | - | - | - | 1 | 0 | De-emphasis for $f_S = 44.1$ kHz |
| - | - | - | - | - | - | 1 | 1 | De-emphasis for $f_S = 48$ kHz |

(1) Default values are in **bold**.

SERIAL DATA INTERFACE REGISTER (0x04)

As shown in [Table 9](#), the TAS5713 supports nine serial data modes. The default is 24-bit, I²S mode.

Table 9. Serial Data Interface Control Register (0x04) Format

| RECEIVE SERIAL DATA INTERFACE FORMAT | WORD LENGTH | D7–D4 | D3 | D2 | D1 | D0 |
|---|----------------|-------------|----------|----------|----------|----------|
| Right-justified | 16 | 0000 | 0 | 0 | 0 | 0 |
| Right-justified | 20 | 0000 | 0 | 0 | 0 | 1 |
| Right-justified | 24 | 0000 | 0 | 0 | 1 | 0 |
| I ² S | 16 | 000 | 0 | 0 | 1 | 1 |
| I ² S | 20 | 0000 | 0 | 1 | 0 | 0 |
| I²S ⁽¹⁾ | 24 | 0000 | 0 | 1 | 0 | 1 |
| Left-justified | 16 | 0000 | 0 | 1 | 1 | 0 |
| Left-justified | 20 | 0000 | 0 | 1 | 1 | 1 |
| Left-justified | 24 | 0000 | 1 | 0 | 0 | 0 |
| Reserved | | 0000 | 1 | 0 | 0 | 1 |
| Reserved | | 0000 | 1 | 0 | 1 | 0 |
| Reserved | | 0000 | 1 | 0 | 1 | 1 |
| Reserved | | 0000 | 1 | 1 | 0 | 0 |
| Reserved | | 0000 | 1 | 1 | 0 | 1 |
| Reserved | | 0000 | 1 | 1 | 1 | 0 |
| Reserved | | 0000 | 1 | 1 | 1 | 1 |

(1) Default values are in **bold**.

SYSTEM CONTROL REGISTER 2 (0x05)

When bit D6 is set low, the system exits all-channel shutdown and starts playing audio; otherwise, the outputs are shut down (hard mute).

Table 10. System Control Register 2 (0x05)

| D7 | D6 | D5 | D4 | D3 | D2 | D1 | D0 | FUNCTION |
|----------|----------|----------|----------|----------|----------|----------|----------|---|
| 0 | – | – | – | – | – | – | – | Mid-Z ramp disabled |
| 1 | – | – | – | – | – | – | – | Mid-Z ramp enabled |
| – | 0 | – | – | – | – | – | – | Exit all-channel shutdown (normal operation) |
| – | 1 | – | – | – | – | – | – | Enter all-channel shutdown (hard mute)⁽¹⁾ |
| – | – | 0 | 0 | 0 | – | – | – | Reserved⁽¹⁾ |
| – | – | – | – | – | 0 | – | – | Reserved⁽¹⁾ |
| – | – | – | – | – | – | 0 | – | A_SEL_FAULT configured as input |
| – | – | – | – | – | – | 1 | – | A_SEL_FAULT configured configured as output to function as A_SEL_FAULT pin. |
| – | – | – | – | – | – | – | 0 | Reserved⁽¹⁾ |

(1) Default values are in **bold**.

SOFT MUTE REGISTER (0x06)

Writing a 1 to any of the following bits sets the output of the respective channel to 50% duty cycle (soft mute).

Table 11. Soft Mute Register (0x06)

| D7 | D6 | D5 | D4 | D3 | D2 | D1 | D0 | FUNCTION |
|----------|----------|----------|----------|----------|----------|----------|----------|------------------------------|
| 0 | 0 | 0 | 0 | 0 | – | – | – | Reserved |
| – | – | – | – | – | 1 | – | – | Soft mute channel 3 |
| – | – | – | – | – | 0 | – | – | Soft unmute channel 3 |
| – | – | – | – | – | – | 1 | – | Soft mute channel 2 |
| – | – | – | – | – | – | 0 | – | Soft unmute channel 2 |
| – | – | – | – | – | – | – | 1 | Soft mute channel 1 |
| – | – | – | – | – | – | – | 0 | Soft unmute channel 1 |

VOLUME REGISTERS (0x07, 0x08, 0x09, 0x0A)

Step size is 0.5 dB.

| | |
|------------------|--------------------------|
| Master volume | – 0x07 (default is mute) |
| Channel-1 volume | – 0x08 (default is 0 dB) |
| Channel-2 volume | – 0x09 (default is 0 dB) |
| Headphone volume | – 0x0A (default is 0 dB) |

Table 12. Master Volume Table

| HEX | dB | HEX | dB | HEX | dB | HEX | dB | HEX | dB | HEX | dB |
|-----|------|-----|-------|-----|-------|-----|-------|-----|-------|-----|-------|
| 00 | 24 | 30 | 0 | 60 | –24 | 90 | –48 | C0 | –72 | F0 | –96 |
| 01 | 23.5 | 31 | –0.5 | 61 | –24.5 | 91 | –48.5 | C1 | –72.5 | F1 | –96.5 |
| 02 | 23 | 32 | –1 | 62 | –25 | 92 | –49 | C2 | –73 | F2 | –97 |
| 03 | 22.5 | 33 | –1.5 | 63 | –25.5 | 93 | –49.5 | C3 | –73.5 | F3 | –97.5 |
| 04 | 22 | 34 | –2 | 64 | –26 | 94 | –50 | C4 | –74 | F4 | –98 |
| 05 | 21.5 | 35 | –2.5 | 65 | –26.5 | 95 | –50.5 | C5 | –74.5 | F5 | –98.5 |
| 06 | 21 | 36 | –3 | 66 | –27 | 96 | –51 | C6 | –75 | F6 | –99 |
| 07 | 20.5 | 37 | –3.5 | 67 | –27.5 | 97 | –51.5 | C7 | –75.5 | F7 | –99.5 |
| 08 | 20 | 38 | –4 | 68 | –28 | 98 | –52 | C8 | –76 | F8 | –100 |
| 09 | 19.5 | 39 | –4.5 | 69 | –28.5 | 99 | –52.5 | C9 | –76.5 | F8 | |
| 0A | 19 | 3A | –5 | 6A | –29 | 9A | –53 | CA | –77 | FA | |
| 0B | 18.5 | 3B | –5.5 | 6B | –29.5 | 9B | –53.5 | CB | –77.5 | FB | |
| 0C | 18 | 3C | –6 | 6C | –30 | 9C | –54 | CC | –78 | FC | |
| 0D | 17.5 | 3D | –6.5 | 6D | –30.5 | 9D | –54.5 | CD | –78.5 | FD | |
| 0E | 17 | 3E | –7 | 6E | –31 | 9E | –55 | CE | –79 | FE | |
| 0F | 16.5 | 3F | –7.5 | 6F | –31.5 | 9F | –55.5 | CF | –79.5 | FF | |
| 10 | 16 | 40 | –8 | 70 | –32 | A0 | –56 | D0 | –80 | | |
| 11 | 15.5 | 41 | –8.5 | 71 | –32.5 | A1 | –56.5 | D1 | –80.5 | | |
| 12 | 15 | 42 | –9 | 72 | –33 | A2 | –57 | D2 | –81 | | |
| 13 | 14.5 | 43 | –9.5 | 73 | –33.5 | A3 | –57.5 | D3 | –81.5 | | |
| 14 | 14 | 44 | –10 | 74 | –34 | A4 | –58 | D4 | –82 | | |
| 15 | 13.5 | 45 | –10.5 | 75 | –34.5 | A5 | –58.5 | D5 | –82.5 | | |
| 16 | 13 | 46 | –11 | 76 | –35 | A6 | –59 | D6 | –83 | | |
| 17 | 12.5 | 37 | –11.5 | 77 | –35.5 | A7 | –59.5 | D7 | –83.5 | | |
| 18 | 12 | 38 | –12 | 78 | –36 | A8 | –60 | D8 | –84 | | |
| 19 | 11.5 | 39 | –12.5 | 79 | –36.5 | A9 | –60.5 | D9 | –84.5 | | |
| 1A | 11 | 4A | –13 | 7A | –37 | AA | –61 | DA | –85 | | |
| 1B | 10.5 | 4B | –13.5 | 7B | –37.5 | AB | –61.5 | DB | –85.5 | | |
| 1C | 10 | 4C | –14 | 7C | –38 | AC | –62 | DC | –86 | | |
| 1D | 9.5 | 4D | –14.5 | 7D | –38.5 | AD | –62.5 | DD | –86.5 | | |
| 1E | 9 | 4E | –15 | 7E | –39 | AE | –63 | DE | –87 | | |
| 1F | 8.5 | 4F | –15.5 | 7F | –39.5 | AF | –63.5 | DF | –87.5 | | |
| 20 | 8 | 50 | –16 | 80 | –40 | B0 | –64 | E0 | –88 | | |
| 21 | 7.5 | 51 | –16.5 | 81 | –40.5 | B1 | –64.5 | E1 | –88.5 | | |
| 22 | 7 | 52 | –17 | 82 | –41 | B2 | –65 | E2 | –89 | | |
| 23 | 6.5 | 53 | –17.5 | 83 | –41.5 | B3 | –65.5 | E3 | –89.5 | | |
| 24 | 6 | 54 | –18 | 84 | –42 | B4 | –66 | E4 | –90 | | |
| 25 | 5.5 | 55 | –18.5 | 85 | –42.5 | B5 | –66.5 | E5 | –90.5 | | |

Table 12. Master Volume Table (continued)

| HEX | dB | HEX | dB | HEX | dB | HEX | dB | HEX | dB | HEX | dB |
|-----|-----|-----|-------|-----|-------|-----|-------|-----|-------|-----|----|
| 26 | 5 | 56 | -19 | 86 | -43 | B6 | -67 | E6 | -91 | | |
| 27 | 4.5 | 547 | -19.5 | 87 | -43.5 | B7 | -67.5 | E7 | -91.5 | | |
| 28 | 4 | 58 | -20 | 88 | -44 | B8 | -68 | E8 | -92 | | |
| 29 | 3.5 | 59 | -20.5 | 89 | -44.5 | B9 | -68.5 | E9 | -92.5 | | |
| 2A | 3 | 5A | -21 | 8A | -45 | BA | -69 | EA | -93 | | |
| 2B | 2.5 | 5B | -21.5 | 8B | -45.5 | BB | -69.5 | EB | -93.5 | | |
| 2C | 2 | 5C | -22 | 8C | -46 | BC | -70 | EC | -94 | | |
| 2D | 1.5 | 5D | -22.5 | 8D | -46.5 | BD | -70.5 | ED | -94.5 | | |
| 2E | 1 | 5E | -23 | 8E | -47 | BE | -71 | EE | -95 | | |
| 2F | 0.5 | 5F | -23.5 | 8F | -47.5 | BF | -71.5 | EF | -95.5 | | |

VOLUME CONFIGURATION REGISTER (0x0E)

Bits D2–D0: Volume slew rate (used to control volume change and MUTE ramp rates). These bits control the number of steps in a volume ramp. Volume steps occur at a rate that depends on the sample rate of the I²S data as follows:

| Sample rate (kHz) | Approximate ramp rate |
|-------------------|-----------------------|
| 8/16/32 | 125 μs/step |
| 11.025/22.05/44.1 | 90.7 μs/step |
| 12/24/48 | 83.3 μs/step |

Table 13. Volume Control Register (0x0E)

| D7 | D6 | D5 | D4 | D3 | D2 | D1 | D0 | FUNCTION |
|----------|----------|----------|----------|----------|----------|----------|----------|---|
| 1 | 0 | 0 | 1 | 0 | – | – | – | Reserved ⁽¹⁾ |
| – | – | – | – | – | 0 | 0 | 0 | Volume slew 512 steps (43 ms volume ramp time at 48 kHz) ⁽¹⁾ |
| – | – | – | – | – | 0 | 0 | 1 | Volume slew 1024 steps (85-ms volume ramp time at 48 kHz) |
| – | – | – | – | – | 0 | 1 | 0 | Volume slew 2048 steps (171-ms volume ramp time at 48 kHz) |
| – | – | – | – | – | 0 | 1 | 1 | Volume slew 256 steps (21-ms volume ramp time at 48 kHz) |
| – | – | – | – | – | 1 | X | X | Reserved |

(1) Default values are in **bold**.

MODULATION LIMIT REGISTER (0x10)

Table 14. Modulation Limit Register (0x10)

| D7 | D6 | D5 | D4 | D3 | D2 | D1 | D0 | MODULATION LIMIT |
|----|----|----|----|----|----------|----------|----------|------------------|
| 0 | 0 | 0 | 0 | 0 | – | – | – | Reserved |
| – | – | – | – | – | 0 | 0 | 0 | 99.2% |
| – | – | – | – | – | 0 | 0 | 1 | 98.4% |
| – | – | – | – | – | 0 | 1 | 0 | 97.7% |
| – | – | – | – | – | 0 | 1 | 1 | 96.9% |
| – | – | – | – | – | 1 | 0 | 0 | 96.1% |
| – | – | – | – | – | 1 | 0 | 1 | 95.3% |
| – | – | – | – | – | 1 | 1 | 0 | 94.5% |
| – | – | – | – | – | 1 | 1 | 1 | 93.8% |

INTERCHANNEL DELAY REGISTERS (0x11, 0x12, 0x13, and 0x14)

Internal PWM Channels 1, 2, $\bar{1}$, and $\bar{2}$ are mapped into registers 0x11, 0x12, 0x13, and 0x14.

Table 15. Channel Interchannel Delay Register Format

| BITS DEFINITION | D7 | D6 | D5 | D4 | D3 | D2 | D1 | D0 | FUNCTION |
|-----------------|----------|----------|----------|----------|----------|----------|----|----|---|
| | 0 | 0 | 0 | 0 | 0 | 0 | – | – | Minimum absolute delay, 0 DCLK cycles |
| | 0 | 1 | 1 | 1 | 1 | 1 | – | – | Maximum positive delay, 31 × 4 DCLK cycles |
| | 1 | 0 | 0 | 0 | 0 | 0 | – | – | Maximum negative delay, –32 × 4 DCLK cycles |
| | | | | | | | 0 | 0 | Reserved |
| SUBADDRESS | D7 | D6 | D5 | D4 | D3 | D2 | D1 | D0 | Delay = (value) × 4 DCLKs |
| 0x11 | 1 | 0 | 1 | 0 | 1 | 1 | – | – | Default value for channel 1 ⁽¹⁾ |
| 0x12 | 0 | 1 | 0 | 1 | 0 | 1 | – | – | Default value for channel 2 ⁽¹⁾ |
| 0x13 | 1 | 0 | 1 | 0 | 1 | 1 | – | – | Default value for channel 1 ⁽¹⁾ |
| 0x14 | 0 | 1 | 0 | 1 | 0 | 1 | – | – | Default value for channel 2 ⁽¹⁾ |

(1) Default values are in **bold**.

ICD settings have high impact on audio performance (e.g., dynamic range, THD, crosstalk, etc.) Therefore, appropriate ICD settings must be used. By default, the device has ICD settings for the AD mode. If used in BD mode, then update these registers before coming out of all-channel shutdown.

| MODE | AD MODE | BD MODE |
|------|---------|---------|
| 0x11 | AC | B8 |
| 0x12 | 54 | 60 |
| 0x13 | AC | A0 |
| 0x14 | 54 | 48 |

PWM SHUTDOWN GROUP REGISTER (0x19)

Settings of this register determine which PWM channels are active. The value should be 0x30 for BTL mode and 0x3A for PBTTL mode. The default value of this register is 0x30. The functionality of this register is tied to the state of bit D5 in the system control register.

This register defines which channels belong to the shutdown group (SDG). If a 1 is set in the shutdown group register, that particular channel is **not** started following an exit *out of all-channel shutdown* command (if bit D5 is set to 0 in system control register 2, 0x05).

Table 16. Shutdown Group Register

| D7 | D6 | D5 | D4 | D3 | D2 | D1 | D0 | FUNCTION |
|----------|----------|----------|----------|----------|----------|----------|----------|---|
| 0 | – | – | – | – | – | – | – | Reserved ⁽¹⁾ |
| – | 0 | – | – | – | – | – | – | Reserved ⁽¹⁾ |
| – | – | 1 | – | – | – | – | – | Reserved ⁽¹⁾ |
| – | – | – | 1 | – | – | – | – | Reserved ⁽¹⁾ |
| – | – | – | – | 0 | – | – | – | PWM channel 4 does not belong to shutdown group. ⁽¹⁾ |
| – | – | – | – | 1 | – | – | – | PWM channel 4 belongs to shutdown group. |
| – | – | – | – | – | 0 | – | – | PWM channel 3 does not belong to shutdown group. ⁽¹⁾ |
| – | – | – | – | – | 1 | – | – | PWM channel 3 belongs to shutdown group. |
| – | – | – | – | – | – | 0 | – | PWM channel 2 does not belong to shutdown group. ⁽¹⁾ |
| – | – | – | – | – | – | 1 | – | PWM channel 2 belongs to shutdown group. |
| – | – | – | – | – | – | – | 0 | PWM channel 1 does not belong to shutdown group. ⁽¹⁾ |
| – | – | – | – | – | – | – | 1 | PWM channel 1 belongs to shutdown group. |

(1) Default values are in **bold**.

START/STOP PERIOD REGISTER (0x1A)

This register is used to control the soft-start and soft-stop period following an enter/exit all-channel shutdown command or change in the PDN state. This helps reduce pops and clicks at start-up and shutdown. The times are only approximate and vary depending on device activity level and I²S clock stability.

Table 17. Start/Stop Period Register (0x1A)

| D7 | D6 | D5 | D4 | D3 | D2 | D1 | D0 | FUNCTION |
|----|----------|----------|----------|----------|----------|----------|----------|--|
| 0 | – | – | – | – | – | – | – | SSTIMER enabled |
| 1 | – | – | – | – | – | – | – | SSTIMER disabled |
| – | 0 | 0 | – | – | – | – | – | Reserved |
| – | – | – | 0 | 0 | – | – | – | No 50% duty cycle start/stop period |
| – | – | – | 0 | 1 | 0 | 0 | 0 | 16.5-ms 50% duty cycle start/stop period |
| – | – | – | 0 | 1 | 0 | 0 | 1 | 23.9-ms 50% duty cycle start/stop period |
| – | – | – | 0 | 1 | 0 | 1 | 0 | 31.4-ms 50% duty cycle start/stop period |
| – | – | – | 0 | 1 | 0 | 1 | 1 | 40.4-ms 50% duty cycle start/stop period |
| – | – | – | 0 | 1 | 1 | 0 | 0 | 53.9-ms 50% duty cycle start/stop period |
| – | – | – | 0 | 1 | 1 | 0 | 1 | 70.3-ms 50% duty cycle start/stop period |
| – | – | – | 0 | 1 | 1 | 1 | 0 | 94.2-ms 50% duty cycle start/stop period |
| – | – | – | 0 | 1 | 1 | 1 | 1 | 125.7-ms 50% duty cycle start/stop period⁽¹⁾ |
| – | – | – | 1 | 0 | 0 | 0 | 0 | 164.6-ms 50% duty cycle start/stop period |
| – | – | – | 1 | 0 | 0 | 0 | 1 | 239.4-ms 50% duty cycle start/stop period |
| – | – | – | 1 | 0 | 0 | 1 | 0 | 314.2-ms 50% duty cycle start/stop period |
| – | – | – | 1 | 0 | 0 | 1 | 1 | 403.9-ms 50% duty cycle start/stop period |
| – | – | – | 1 | 0 | 1 | 0 | 0 | 538.6-ms 50% duty cycle start/stop period |
| – | – | – | 1 | 0 | 1 | 0 | 1 | 703.1-ms 50% duty cycle start/stop period |
| – | – | – | 1 | 0 | 1 | 1 | 0 | 942.5-ms 50% duty cycle start/stop period |
| – | – | – | 1 | 0 | 1 | 1 | 1 | 1256.6-ms 50% duty cycle start/stop period |
| – | – | – | 1 | 1 | 0 | 0 | 0 | 1728.1-ms 50% duty cycle start/stop period |
| – | – | – | 1 | 1 | 0 | 0 | 1 | 2513.6-ms 50% duty cycle start/stop period |
| – | – | – | 1 | 1 | 0 | 1 | 0 | 3299.1-ms 50% duty cycle start/stop period |
| – | – | – | 1 | 1 | 0 | 1 | 1 | 4241.7-ms 50% duty cycle start/stop period |
| – | – | – | 1 | 1 | 1 | 0 | 0 | 5655.6-ms 50% duty cycle start/stop period |
| – | – | – | 1 | 1 | 1 | 0 | 1 | 7383.7-ms 50% duty cycle start/stop period |
| – | – | – | 1 | 1 | 1 | 1 | 0 | 9897.3-ms 50% duty cycle start/stop period |
| – | – | – | 1 | 1 | 1 | 1 | 1 | 13,196.4-ms 50% duty cycle start/stop period |

(1) Default values are in **bold**.

OSCILLATOR TRIM REGISTER (0x1B)

The TAS5713 PWM processor contains an internal oscillator to support autodetect of I²S clock rates. This reduces system cost because an external reference is not required. Currently, TI recommends a reference resistor value of 18.2 kΩ (1%). This should be connected between OSC_RES and DVSSO.

Writing 0x00 to register 0x1B enables the trim that was programmed at the factory.

Note that trim must always be run following reset of the device.

Table 18. Oscillator Trim Register (0x1B)

| D7 | D6 | D5 | D4 | D3 | D2 | D1 | D0 | FUNCTION |
|----------|----------|----------|----------|----------|----------|----|----------|---|
| 1 | – | – | – | – | – | – | – | Reserved ⁽¹⁾ |
| – | 0 | – | – | – | – | – | – | Oscillator trim not done (read-only) ⁽¹⁾ |
| – | 1 | – | – | – | – | – | – | Oscillator trim done (read only) |
| – | – | 0 | 0 | 0 | 0 | – | – | Reserved ⁽¹⁾ |
| – | – | – | – | – | – | 0 | – | Select factory trim (Write a 0 to select factory trim; default is 1.) |
| – | – | – | – | – | – | 1 | – | Factory trim disabled ⁽¹⁾ |
| – | – | – | – | – | – | – | 0 | Reserved ⁽¹⁾ |

(1) Default values are in **bold**.

BKND_ERR REGISTER (0x1C)

When a back-end error signal is received from the internal power stage, the power stage is reset stopping all PWM activity. Subsequently, the modulator waits approximately for the time listed in [Table 19](#) before attempting to re-start the power stage.

Table 19. BKND_ERR Register (0x1C)⁽¹⁾

| D7 | D6 | D5 | D4 | D3 | D2 | D1 | D0 | FUNCTION |
|----|----|----|----|----------|----------|----------|----------|---|
| 0 | 0 | 0 | 0 | 0 | 0 | 0 | X | Reserved |
| – | – | – | – | 0 | 0 | 1 | 0 | Set back-end reset period to 299 ms ⁽²⁾ |
| – | – | – | – | 0 | 0 | 1 | 1 | Set back-end reset period to 449 ms |
| – | – | – | – | 0 | 1 | 0 | 0 | Set back-end reset period to 598 ms |
| – | – | – | – | 0 | 1 | 0 | 1 | Set back-end reset period to 748 ms |
| – | – | – | – | 0 | 1 | 1 | 0 | Set back-end reset period to 898 ms |
| – | – | – | – | 0 | 1 | 1 | 1 | Set back-end reset period to 1047 ms |
| – | – | – | – | 1 | 0 | 0 | 0 | Set back-end reset period to 1197 ms |
| – | – | – | – | 1 | 0 | 0 | 1 | Set back-end reset period to 1346 ms |
| – | – | – | – | 1 | 0 | 1 | X | Set back-end reset period to 1496 ms |
| – | – | – | – | 1 | 1 | X | X | Set back-end reset period to 1496 ms |

(1) This register can be written only with a non-reserved value. Also this register can be written once after the reset.

(2) Default values are in **bold**.

INPUT MULTIPLEXER REGISTER (0x20)

This register controls the modulation scheme (AD or BD mode) as well as the routing of I²S audio to the internal channels.

Table 20. Input Multiplexer Register (0x20)

| D31 | D30 | D29 | D28 | D27 | D26 | D25 | D24 | FUNCTION |
|-----|----------|----------|----------|----------|----------|----------|----------|--|
| 0 | 0 | 0 | 0 | 0 | 0 | 0 | 0 | Reserved ⁽¹⁾ |
| D23 | D22 | D21 | D20 | D19 | D18 | D17 | D16 | FUNCTION |
| 0 | – | – | – | – | – | – | – | Channel-1 AD mode |
| 1 | – | – | – | – | – | – | – | Channel-1 BD mode |
| – | 0 | 0 | 0 | – | – | – | – | SDIN-L to channel 1⁽¹⁾ |
| – | 0 | 0 | 1 | – | – | – | – | SDIN-R to channel 1 |
| – | 0 | 1 | 0 | – | – | – | – | Reserved |
| – | 0 | 1 | 1 | – | – | – | – | Reserved |
| – | 1 | 0 | 0 | – | – | – | – | Reserved |
| – | 1 | 0 | 1 | – | – | – | – | Reserved |
| – | 1 | 1 | 0 | – | – | – | – | Ground (0) to channel 1 |
| – | 1 | 1 | 1 | – | – | – | – | Reserved |
| – | – | – | – | 0 | – | – | – | Channel 2 AD mode⁽¹⁾ |
| – | – | – | – | 1 | – | – | – | Channel 2 BD mode |
| – | – | – | – | – | 0 | 0 | 0 | SDIN-L to channel 2 |
| – | – | – | – | – | 0 | 0 | 1 | SDIN-R to channel 2⁽¹⁾ |
| – | – | – | – | – | 0 | 1 | 0 | Reserved |
| – | – | – | – | – | 0 | 1 | 1 | Reserved |
| – | – | – | – | – | 1 | 0 | 0 | Reserved |
| – | – | – | – | – | 1 | 0 | 1 | Reserved |
| – | – | – | – | – | 1 | 1 | 0 | Ground (0) to channel 2 |
| – | – | – | – | – | 1 | 1 | 1 | Reserved |
| D15 | D14 | D13 | D12 | D11 | D10 | D9 | D8 | FUNCTION |
| 0 | 1 | 1 | 1 | 0 | 1 | 1 | 1 | Reserved ⁽¹⁾ |
| D7 | D6 | D5 | D4 | D3 | D2 | D1 | D0 | FUNCTION |
| 0 | 1 | 1 | 1 | 0 | 0 | 1 | 0 | Reserved ⁽¹⁾ |

(1) Default values are in **bold**.

CHANNEL 4 SOURCE SELECT REGISTER (0x21)

This register selects the channel 4 source.

Table 21. Subchannel Control Register (0x21)

| D31 | D30 | D29 | D28 | D27 | D26 | D25 | D24 | FUNCTION |
|----------|----------|----------|----------|----------|----------|----------|----------|-------------------------|
| 0 | 0 | 0 | 0 | 0 | 0 | 0 | 0 | Reserved ⁽¹⁾ |
| D23 | D22 | D21 | D20 | D19 | D18 | D17 | D16 | FUNCTION |
| 0 | 0 | 0 | 0 | 0 | 0 | 0 | 0 | Reserved ⁽¹⁾ |
| D15 | D14 | D13 | D12 | D11 | D10 | D9 | D8 | FUNCTION |
| 0 | 1 | 0 | 0 | 0 | 0 | 1 | | Reserved ⁽¹⁾ |
| – | – | – | – | – | – | – | 0 | (L + R)/2 |
| – | – | – | – | – | – | – | 1 | Left-channel post-BQ |
| D7 | D6 | D5 | D4 | D3 | D2 | D1 | D0 | FUNCTION |
| 0 | 0 | 0 | 0 | 0 | 0 | 1 | 1 | Reserved ⁽¹⁾ |

(1) Default values are in **bold**.

PWM OUTPUT MUX REGISTER (0x25)

This DAP output mux selects which internal PWM channel is output to the external pins. Any channel can be output to any external output pin.

Bits D21–D20: Selects which PWM channel is output to OUT_A

Bits D17–D16: Selects which PWM channel is output to OUT_B

Bits D13–D12: Selects which PWM channel is output to OUT_C

Bits D09–D08: Selects which PWM channel is output to OUT_D

Note that channels are encoded so that channel 1 = 0x00, channel 2 = 0x01, ..., channel 4 = 0x03.

Table 22. PWM Output Mux Register (0x25)

| D31 | D30 | D29 | D28 | D27 | D26 | D25 | D24 | FUNCTION |
|----------|----------|----------|----------|----------|----------|----------|----------|---|
| 0 | 0 | 0 | 0 | 0 | 0 | 0 | 1 | Reserved ⁽¹⁾ |
| D23 | D22 | D21 | D20 | D19 | D18 | D17 | D16 | FUNCTION |
| 0 | 0 | – | – | – | – | – | – | Reserved ⁽¹⁾ |
| – | – | 0 | 0 | – | – | – | – | Multiplex channel 1 to OUT_A ⁽¹⁾ |
| – | – | 0 | 1 | – | – | – | – | Multiplex channel 2 to OUT_A |
| – | – | 1 | 0 | – | – | – | – | Multiplex channel 1 to OUT_A |
| – | – | 1 | 1 | – | – | – | – | Multiplex channel 2 to OUT_A |
| – | – | – | – | 0 | 0 | – | – | Reserved ⁽¹⁾ |
| – | – | – | – | – | – | 0 | 0 | Multiplex channel 1 to OUT_B |
| – | – | – | – | – | – | 0 | 1 | Multiplex channel 2 to OUT_B |
| – | – | – | – | – | – | 1 | 0 | Multiplex channel 1 to OUT_B ⁽¹⁾ |
| – | – | – | – | – | – | 1 | 1 | Multiplex channel 2 to OUT_B |
| D15 | D14 | D13 | D12 | D11 | D10 | D9 | D8 | FUNCTION |
| 0 | 0 | – | – | – | – | – | – | Reserved ⁽¹⁾ |
| – | – | 0 | 0 | – | – | – | – | Multiplex channel 1 to OUT_C |
| – | – | 0 | 1 | – | – | – | – | Multiplex channel 2 to OUT_C ⁽¹⁾ |
| – | – | 1 | 0 | – | – | – | – | Multiplex channel 1 to OUT_C |

(1) Default values are in **bold**.

Table 22. PWM Output Mux Register (0x25) (continued)

| | | | | | | | | |
|-----------|-----------|-----------|-----------|-----------|-----------|-----------|-----------|--|
| – | – | 1 | 1 | – | – | – | – | Multiplex channel 2 to OUT_C |
| – | – | – | – | 0 | 0 | – | – | Reserved ⁽¹⁾ |
| – | – | – | – | – | – | 0 | 0 | Multiplex channel 1 to OUT_D |
| – | – | – | – | – | – | 0 | 1 | Multiplex channel 2 to OUT_D |
| – | – | – | – | – | – | 1 | 0 | Multiplex channel 1 to OUT_D |
| – | – | – | – | – | – | 1 | 1 | Multiplex channel 2 to OUT_D ⁽¹⁾ |
| D7 | D6 | D5 | D4 | D3 | D2 | D1 | D0 | FUNCTION |
| 0 | 1 | 0 | 0 | 0 | 1 | 0 | 1 | Reserved ⁽¹⁾ |

DRC CONTROL (0x46)**Table 23. DRC Control Register (0x46)**

| | | | | | | | | |
|------------|------------|------------|------------|------------|------------|------------|------------|---------------------------------------|
| D31 | D30 | D29 | D28 | D27 | D26 | D25 | D24 | FUNCTION |
| 0 | 0 | 0 | 0 | 0 | 0 | 0 | 0 | Reserved ⁽¹⁾ |
| D23 | D22 | D21 | D20 | D19 | D18 | D17 | D16 | FUNCTION |
| 0 | 0 | 0 | 0 | 0 | 0 | 0 | 0 | Reserved ⁽¹⁾ |
| D15 | D14 | D13 | D12 | D11 | D10 | D9 | D8 | FUNCTION |
| 0 | 0 | 0 | 0 | 0 | 0 | 0 | 0 | Reserved ⁽¹⁾ |
| D7 | D6 | D5 | D4 | D3 | D2 | D1 | D0 | FUNCTION |
| – | – | 0 | – | – | – | – | – | Reserved ⁽²⁾ |
| – | – | 1 | – | – | – | – | – | Reserved ⁽²⁾ |
| – | – | – | 0 | – | – | – | – | Reserved ^{(1) (2)} |
| – | – | – | – | – | 0 | – | – | Reserved ^{(1) (2)} |
| – | – | – | – | – | – | 0 | – | DRC2 turned OFF ⁽¹⁾ |
| – | – | – | – | – | – | 1 | – | DRC2 turned ON |
| – | – | – | – | – | – | – | 0 | DRC1 turned OFF ⁽¹⁾ |
| – | – | – | – | – | – | – | 1 | DRC1 turned ON |
| 0 | 0 | – | – | 0 | – | – | – | Reserved ⁽¹⁾ |

(1) Default values are in **bold**.

(2) Reserved registers should not be accessed.

BANK SWITCH AND EQ CONTROL (0x50)
Table 24. Bank Switching Command

| D31 | D30 | D29 | D28 | D27 | D26 | D25 | D24 | FUNCTION |
|----------|----------|----------|----------|----------|----------|----------|----------|---|
| 0 | – | – | – | – | – | – | – | 32 kHz, does not use bank 3⁽¹⁾ |
| 1 | – | – | – | – | – | – | – | 32 kHz, uses bank 3 |
| – | 0 | – | – | – | – | – | – | Reserved |
| – | – | 0 | – | – | – | – | – | Reserved |
| – | – | – | 0 | – | – | – | – | 44.1/48 kHz, does not use bank 3⁽¹⁾ |
| – | – | – | 1 | – | – | – | – | 44.1/48 kHz, uses bank 3 |
| – | – | – | – | 0 | – | – | – | 16 kHz, does not use bank 3 |
| – | – | – | – | 1 | – | – | – | 16 kHz, uses bank 3⁽¹⁾ |
| – | – | – | – | – | 0 | – | – | 22.025/24 kHz, does not use bank 3 |
| – | – | – | – | – | 1 | – | – | 22.025/24 kHz, uses bank 3⁽¹⁾ |
| – | – | – | – | – | – | 0 | – | 8 kHz, does not use bank 3 |
| – | – | – | – | – | – | 1 | – | 8 kHz, uses bank 3⁽¹⁾ |
| – | – | – | – | – | – | – | 0 | 11.025 kHz/12, does not use bank 3 |
| – | – | – | – | – | – | – | 1 | 11.025/12 kHz, uses bank 3⁽¹⁾ |
| D23 | D22 | D21 | D20 | D19 | D18 | D17 | D16 | FUNCTION |
| 0 | – | – | – | – | – | – | – | 32 kHz, does not use bank 2⁽¹⁾ |
| 1 | – | – | – | – | – | – | – | 32 kHz, uses bank 2 |
| – | 1 | – | – | – | – | – | – | Reserved⁽¹⁾ |
| – | – | 1 | – | – | – | – | – | Reserved⁽¹⁾ |
| – | – | – | 0 | – | – | – | – | 44.1/48 kHz, does not use bank 2 |
| – | – | – | 1 | – | – | – | – | 44.1/48 kHz, uses bank 2⁽¹⁾ |
| – | – | – | – | 0 | – | – | – | 16 kHz, does not use bank 2⁽¹⁾ |
| – | – | – | – | 1 | – | – | – | 16 kHz, uses bank 2 |
| – | – | – | – | – | 0 | – | – | 22.025/24 kHz, does not use bank 2⁽¹⁾ |
| – | – | – | – | – | 1 | – | – | 22.025/24 kHz, uses bank 2 |
| – | – | – | – | – | – | 0 | – | 8 kHz, does not use bank 2⁽¹⁾ |
| – | – | – | – | – | – | 1 | – | 8 kHz, uses bank 2 |
| – | – | – | – | – | – | – | 0 | 11.025/12 kHz, does not use bank 2⁽¹⁾ |
| – | – | – | – | – | – | – | 1 | 11.025/12 kHz, uses bank 2 |
| D15 | D14 | D13 | D12 | D11 | D10 | D9 | D8 | FUNCTION |
| 0 | – | – | – | – | – | – | – | 32 kHz, does not use bank 1 |
| 1 | – | – | – | – | – | – | – | 32 kHz, uses bank 1⁽¹⁾ |
| – | 0 | – | – | – | – | – | – | Reserved |
| – | – | 0 | – | – | – | – | – | Reserved |
| – | – | – | 0 | – | – | – | – | 44.1/48 kHz, does not use bank 1⁽¹⁾ |
| – | – | – | 1 | – | – | – | – | 44.1/48 kHz, uses bank 1 |
| – | – | – | – | 0 | – | – | – | 16 kHz, does not use bank 1⁽¹⁾ |
| – | – | – | – | 1 | – | – | – | 16 kHz, uses bank 1 |
| – | – | – | – | – | 0 | – | – | 22.025/24 kHz, does not use bank 1⁽¹⁾ |
| – | – | – | – | – | 1 | – | – | 22.025/24 kHz, uses bank 1 |
| – | – | – | – | – | – | 0 | – | 8 kHz, does not use bank 1⁽¹⁾ |
| – | – | – | – | – | – | 1 | – | 8 kHz, uses bank 1 |
| – | – | – | – | – | – | – | 0 | 11.025/12 kHz, does not use bank 1⁽¹⁾ |
| – | – | – | – | – | – | – | 1 | 11.025/12 kHz, uses bank 1 |

(1) Default values are in **bold**.

Table 24. Bank Switching Command (continued)

| D7 | D6 | D5 | D4 | D3 | D2 | D1 | D0 | FUNCTION |
|----------|----------|----------|----------|----------|----------|----------|----------|---|
| 0 | | | | | | | | EQ ON ⁽²⁾ |
| 1 | – | – | – | – | – | – | – | EQ OFF (bypass BQ 0–7 of channels 1 and 2) |
| – | 0 | – | – | – | – | – | – | Reserved ⁽²⁾ |
| – | – | 0 | – | – | – | – | – | Ignore bank-mapping in bits D31–D8. Use default mapping. ⁽²⁾ |
| | | 1 | | | | | | Use bank-mapping in bits D31–D8. |
| – | – | – | 0 | – | – | – | – | L and R can be written independently. ⁽²⁾ |
| – | – | – | 1 | – | – | – | – | L and R are ganged for EQ biquads; a write to the left-channel biquad is also written to the right-channel biquad. (0x29–0x2F is ganged to 0x30–0x36. Also, 0x58–0x5B is ganged to 0x5C–0x5F. |
| – | – | – | – | 0 | – | – | – | Reserved ⁽²⁾ |
| – | – | – | – | – | 0 | 0 | 0 | No bank switching. All updates to DAP ⁽²⁾ |
| – | – | – | – | – | 0 | 0 | 1 | Configure bank 1 (32 kHz by default) |
| – | – | – | – | – | 0 | 1 | 0 | Configure bank 2 (44.1/48 kHz by default) |
| – | – | – | – | – | 0 | 1 | 1 | Configure bank 3 (other sample rates by default) |
| – | – | – | – | – | 1 | 0 | 0 | Automatic bank selection |
| – | – | – | – | – | 1 | 0 | 1 | Reserved |
| – | – | – | – | – | 1 | 1 | X | Reserved |

(2) Default values are in **bold**.

REVISION HISTORY

| Changes from Original (December 2009) to Revision A | Page |
|---|-----------|
| • Replaced the Dissipations Ratings Table with the Thermal Information Table | 8 |
| • Changed Section: DEVICE PROTECTION SYSTEM | 22 |
| • Changed Section: Overcurrent (OC) Protection With Current Limiting | 22 |
| • Changed Section: Overcurrent (OC) Protection With Current Limiting and Overload Detection | 23 |

PACKAGING INFORMATION

| Orderable Device | Status (1) | Package Type | Package Drawing | Pins | Package Qty | Eco Plan (2) | Lead/Ball Finish | MSL Peak Temp (3) | Op Temp (°C) | Top-Side Markings (4) | Samples |
|------------------|---------------|--------------|-----------------|------|-------------|-------------------------|------------------|----------------------|--------------|--------------------------|-------------------------|
| TAS5713PHPR | ACTIVE | HTQFP | PHP | 48 | 1000 | Green (RoHS & no Sb/Br) | CU NIPDAU | Level-3-260C-168 HR | 0 to 85 | TAS5713 | Samples |

(1) The marketing status values are defined as follows:

ACTIVE: Product device recommended for new designs.

LIFEBUY: TI has announced that the device will be discontinued, and a lifetime-buy period is in effect.

NRND: Not recommended for new designs. Device is in production to support existing customers, but TI does not recommend using this part in a new design.

PREVIEW: Device has been announced but is not in production. Samples may or may not be available.

OBSOLETE: TI has discontinued the production of the device.

(2) Eco Plan - The planned eco-friendly classification: Pb-Free (RoHS), Pb-Free (RoHS Exempt), or Green (RoHS & no Sb/Br) - please check <http://www.ti.com/productcontent> for the latest availability information and additional product content details.

TBD: The Pb-Free/Green conversion plan has not been defined.

Pb-Free (RoHS): TI's terms "Lead-Free" or "Pb-Free" mean semiconductor products that are compatible with the current RoHS requirements for all 6 substances, including the requirement that lead not exceed 0.1% by weight in homogeneous materials. Where designed to be soldered at high temperatures, TI Pb-Free products are suitable for use in specified lead-free processes.

Pb-Free (RoHS Exempt): This component has a RoHS exemption for either 1) lead-based flip-chip solder bumps used between the die and package, or 2) lead-based die adhesive used between the die and leadframe. The component is otherwise considered Pb-Free (RoHS compatible) as defined above.

Green (RoHS & no Sb/Br): TI defines "Green" to mean Pb-Free (RoHS compatible), and free of Bromine (Br) and Antimony (Sb) based flame retardants (Br or Sb do not exceed 0.1% by weight in homogeneous material)

(3) MSL, Peak Temp. -- The Moisture Sensitivity Level rating according to the JEDEC industry standard classifications, and peak solder temperature.

(4) Multiple Top-Side Markings will be inside parentheses. Only one Top-Side Marking contained in parentheses and separated by a "~" will appear on a device. If a line is indented then it is a continuation of the previous line and the two combined represent the entire Top-Side Marking for that device.

Important Information and Disclaimer: The information provided on this page represents TI's knowledge and belief as of the date that it is provided. TI bases its knowledge and belief on information provided by third parties, and makes no representation or warranty as to the accuracy of such information. Efforts are underway to better integrate information from third parties. TI has taken and continues to take reasonable steps to provide representative and accurate information but may not have conducted destructive testing or chemical analysis on incoming materials and chemicals. TI and TI suppliers consider certain information to be proprietary, and thus CAS numbers and other limited information may not be available for release.

In no event shall TI's liability arising out of such information exceed the total purchase price of the TI part(s) at issue in this document sold by TI to Customer on an annual basis.

PHP (S-PQFP-G48)

PowerPAD™ PLASTIC QUAD FLATPACK



- NOTES:
- All linear dimensions are in millimeters.
 - This drawing is subject to change without notice.
 - Body dimensions do not include mold flash or protrusion.
 - This package is designed to be soldered to a thermal pad on the board. Refer to Technical Brief, PowerPad Thermally Enhanced Package, Texas Instruments Literature No. SLMA002 for information regarding recommended board layout. This document is available at www.ti.com <<http://www.ti.com>>.
 - Falls within JEDEC MS-026

PowerPAD is a trademark of Texas Instruments.

THERMAL PAD MECHANICAL DATA

PHP (S-PQFP-G48)

PowerPAD™ PLASTIC QUAD FLATPACK

THERMAL INFORMATION

This PowerPAD™ package incorporates an exposed thermal pad that is designed to be attached to a printed circuit board (PCB). The thermal pad must be soldered directly to the PCB. After soldering, the PCB can be used as a heatsink. In addition, through the use of thermal vias, the thermal pad can be attached directly to the appropriate copper plane shown in the electrical schematic for the device, or alternatively, can be attached to a special heatsink structure designed into the PCB. This design optimizes the heat transfer from the integrated circuit (IC).

For additional information on the PowerPAD package and how to take advantage of its heat dissipating abilities, refer to Technical Brief, PowerPAD Thermally Enhanced Package, Texas Instruments Literature No. SLMA002 and Application Brief, PowerPAD Made Easy, Texas Instruments Literature No. SLMA004. Both documents are available at www.ti.com.

The exposed thermal pad dimensions for this package are shown in the following illustration.

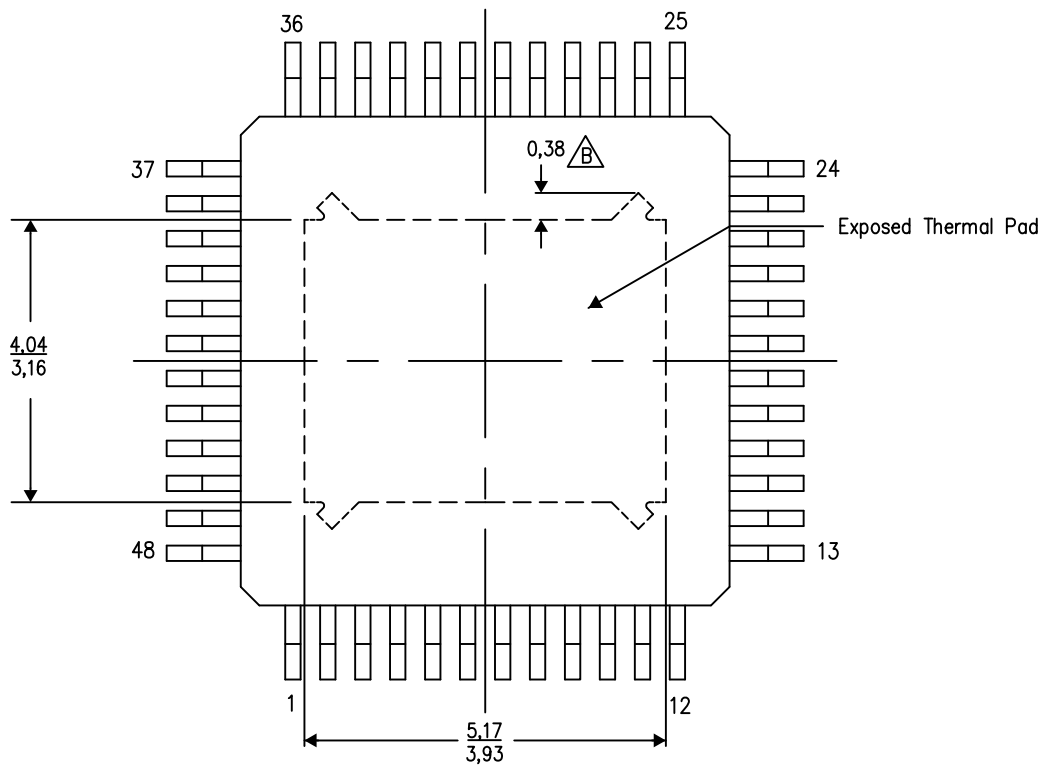

Top View

Exposed Thermal Pad Dimensions

4206329-9/N 04/12

NOTE: A. All linear dimensions are in millimeters

$\triangle B$ Tie strap features may not be present.

PowerPAD is a trademark of Texas Instruments

PHP (S-PQFP-G48)

PowerPAD™ PLASTIC QUAD FLATPACK

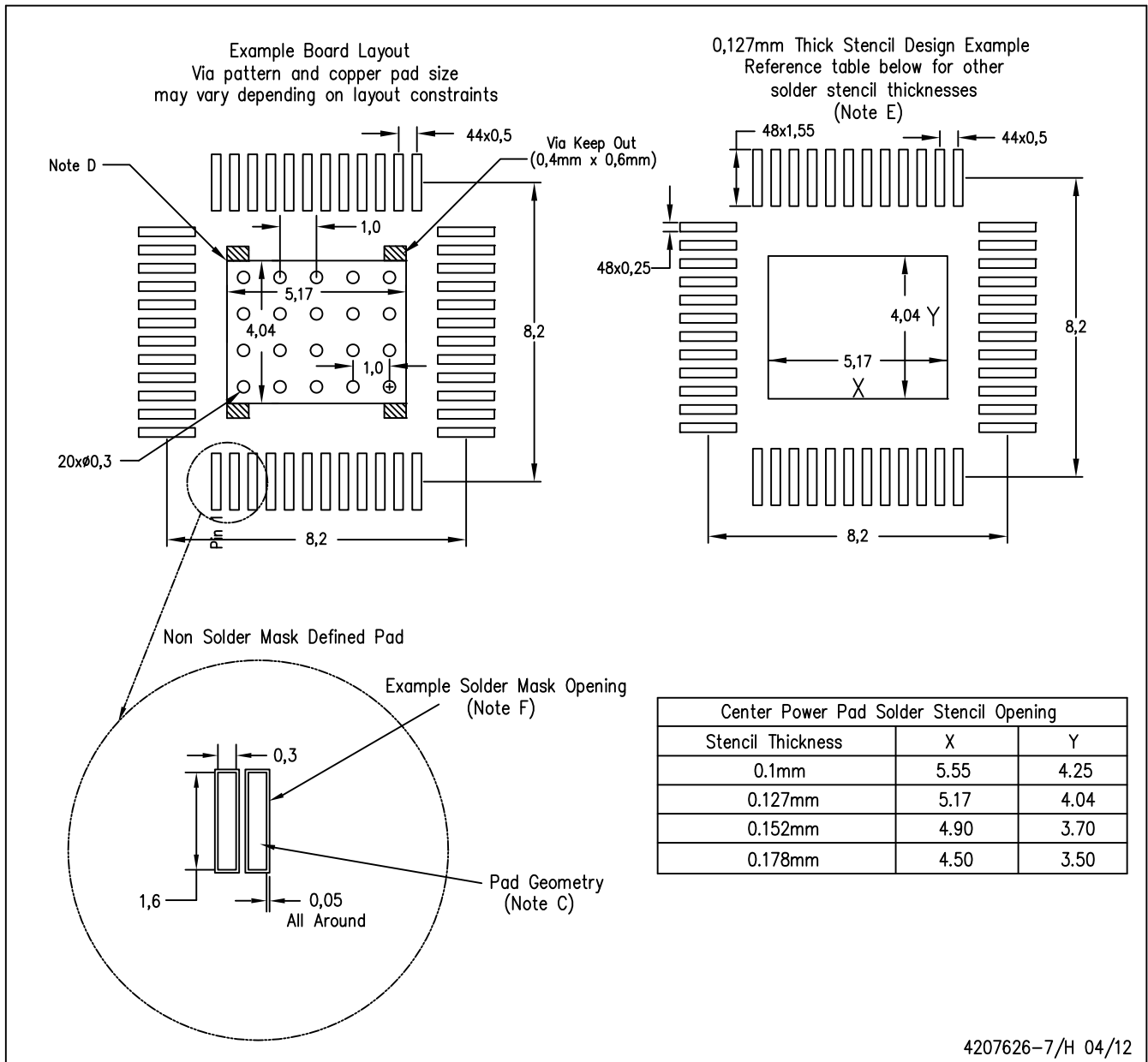

4207626-7/H 04/12

- NOTES:
- A. All linear dimensions are in millimeters.
 - B. This drawing is subject to change without notice.
 - C. Publication IPC-7351 is recommended for alternate designs.
 - D. This package is designed to be soldered to a thermal pad on the board. Refer to Technical Brief, PowerPAD Thermally Enhanced Package, Texas Instruments Literature No. SLMA002, SLMA004, and also the Product Data Sheets for specific thermal information, via requirements, and recommended board layout. These documents are available at www.ti.com <<http://www.ti.com>>.
 - E. Laser cutting apertures with trapezoidal walls and also rounding corners will offer better paste release. Customers should contact their board assembly site for stencil design recommendations. Refer to IPC 7525 for stencil design considerations.
 - F. Customers should contact their board fabrication site for recommended solder mask tolerances and via tenting options for vias placed in the thermal pad.

PowerPAD is a trademark of Texas Instruments

IMPORTANT NOTICE

Texas Instruments Incorporated and its subsidiaries (TI) reserve the right to make corrections, enhancements, improvements and other changes to its semiconductor products and services per JESD46, latest issue, and to discontinue any product or service per JESD48, latest issue. Buyers should obtain the latest relevant information before placing orders and should verify that such information is current and complete. All semiconductor products (also referred to herein as "components") are sold subject to TI's terms and conditions of sale supplied at the time of order acknowledgment.

TI warrants performance of its components to the specifications applicable at the time of sale, in accordance with the warranty in TI's terms and conditions of sale of semiconductor products. Testing and other quality control techniques are used to the extent TI deems necessary to support this warranty. Except where mandated by applicable law, testing of all parameters of each component is not necessarily performed.

TI assumes no liability for applications assistance or the design of Buyers' products. Buyers are responsible for their products and applications using TI components. To minimize the risks associated with Buyers' products and applications, Buyers should provide adequate design and operating safeguards.

TI does not warrant or represent that any license, either express or implied, is granted under any patent right, copyright, mask work right, or other intellectual property right relating to any combination, machine, or process in which TI components or services are used. Information published by TI regarding third-party products or services does not constitute a license to use such products or services or a warranty or endorsement thereof. Use of such information may require a license from a third party under the patents or other intellectual property of the third party, or a license from TI under the patents or other intellectual property of TI.

Reproduction of significant portions of TI information in TI data books or data sheets is permissible only if reproduction is without alteration and is accompanied by all associated warranties, conditions, limitations, and notices. TI is not responsible or liable for such altered documentation. Information of third parties may be subject to additional restrictions.

Resale of TI components or services with statements different from or beyond the parameters stated by TI for that component or service voids all express and any implied warranties for the associated TI component or service and is an unfair and deceptive business practice. TI is not responsible or liable for any such statements.

Buyer acknowledges and agrees that it is solely responsible for compliance with all legal, regulatory and safety-related requirements concerning its products, and any use of TI components in its applications, notwithstanding any applications-related information or support that may be provided by TI. Buyer represents and agrees that it has all the necessary expertise to create and implement safeguards which anticipate dangerous consequences of failures, monitor failures and their consequences, lessen the likelihood of failures that might cause harm and take appropriate remedial actions. Buyer will fully indemnify TI and its representatives against any damages arising out of the use of any TI components in safety-critical applications.

In some cases, TI components may be promoted specifically to facilitate safety-related applications. With such components, TI's goal is to help enable customers to design and create their own end-product solutions that meet applicable functional safety standards and requirements. Nonetheless, such components are subject to these terms.

No TI components are authorized for use in FDA Class III (or similar life-critical medical equipment) unless authorized officers of the parties have executed a special agreement specifically governing such use.

Only those TI components which TI has specifically designated as military grade or "enhanced plastic" are designed and intended for use in military/aerospace applications or environments. Buyer acknowledges and agrees that any military or aerospace use of TI components which have **not** been so designated is solely at the Buyer's risk, and that Buyer is solely responsible for compliance with all legal and regulatory requirements in connection with such use.

TI has specifically designated certain components as meeting ISO/TS16949 requirements, mainly for automotive use. In any case of use of non-designated products, TI will not be responsible for any failure to meet ISO/TS16949.

Products

| | |
|------------------------------|--|
| Audio | www.ti.com/audio |
| Amplifiers | amplifier.ti.com |
| Data Converters | dataconverter.ti.com |
| DLP® Products | www.dlp.com |
| DSP | dsp.ti.com |
| Clocks and Timers | www.ti.com/clocks |
| Interface | interface.ti.com |
| Logic | logic.ti.com |
| Power Mgmt | power.ti.com |
| Microcontrollers | microcontroller.ti.com |
| RFID | www.ti-rfid.com |
| OMAP Applications Processors | www.ti.com/omap |
| Wireless Connectivity | www.ti.com/wirelessconnectivity |

Applications

| | |
|-------------------------------|--|
| Automotive and Transportation | www.ti.com/automotive |
| Communications and Telecom | www.ti.com/communications |
| Computers and Peripherals | www.ti.com/computers |
| Consumer Electronics | www.ti.com/consumer-apps |
| Energy and Lighting | www.ti.com/energy |
| Industrial | www.ti.com/industrial |
| Medical | www.ti.com/medical |
| Security | www.ti.com/security |
| Space, Avionics and Defense | www.ti.com/space-avionics-defense |
| Video and Imaging | www.ti.com/video |

TI E2E Community

e2e.ti.com