

2 W Constant Output Power Class-D Audio Amplifier With Adaptive Boost Converter and Battery Tracking SpeakerGuard™ AGC

 Check for Samples: [TPA2015D1](#)

FEATURES

- **Built-In SpeakerGuard™ Automatic Gain Control (AGC) with Enhanced Battery Tracking**
 - Limits Battery Current Consumption
 - Prevents Audio Clipping
- **2 W into 8 Ω Load From 3.6 V Supply (6% THD)**
- **Integrated Adaptive Boost Converter**
 - Increases Efficiency at Low Output Power
- **Low Quiescent Current of 1.7 mA from 3.6 V**
- **Operates From 2.5 V to 5.2 V**
- **Thermal and Short-Circuit Protection with Auto Recovery**
- **Three Gain Settings: 6 dB, 15.5 dB, and 20 dB**
- **Independent Control for Boost and Class-D**
- **Pin-to-Pin Compatible with TPA2013D1**
- **Available in 1.954 mm × 1.954 mm 16-ball WCSP Package**

APPLICATIONS

- Cell Phones, PDA, GPS
- Portable Electronics and Speakers

SIMPLIFIED APPLICATION DIAGRAM

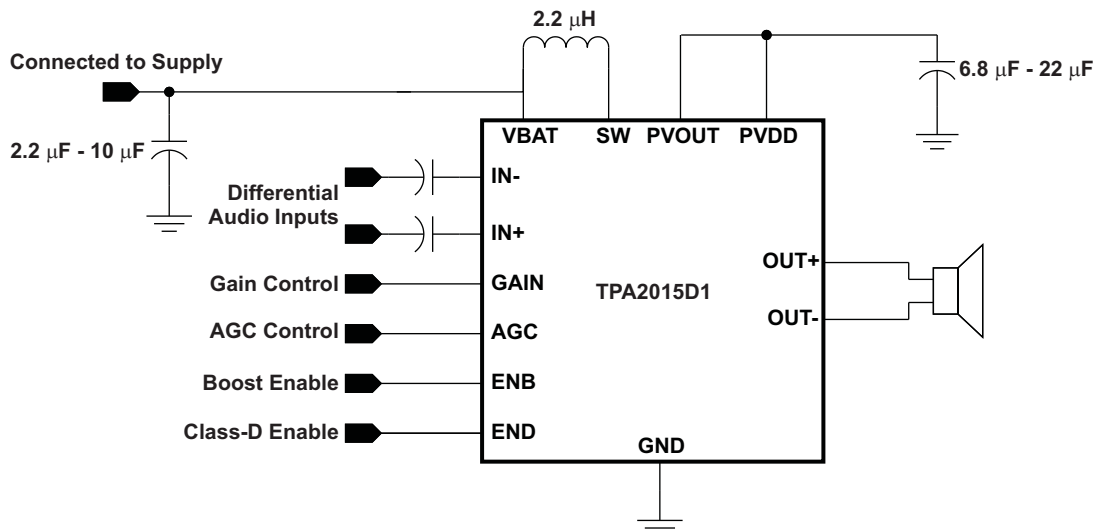

DESCRIPTION

The TPA2015D1 is a high efficiency Class-D audio power amplifier with battery-tracking SpeakerGuard™ AGC technology and an integrated adaptive boost converter that enhances efficiency at low output power. It drives up to 2 W into an 8 Ω speaker (6% THD). With 85% typical efficiency, the TPA2015D1 helps extend battery life when playing audio.

The built-in boost converter generates a 5.5 V supply voltage for the Class-D amplifier. This provides a louder audio output than a stand-alone amplifier directly connected to the battery. The SpeakerGuard™ AGC adjusts the Class-D gain to limit battery current and prevent heavy clipping.

The TPA2015D1 has an integrated low-pass filter to improve the RF rejection and reduce DAC out-of-band noise, increasing the signal to noise ratio (SNR).

The TPA2015D1 is available in a space saving 1.954 mm × 1.954 mm, 0.5 mm pitch WCSP package (YZH).



Please be aware that an important notice concerning availability, standard warranty, and use in critical applications of Texas Instruments semiconductor products and disclaimers thereto appears at the end of this data sheet.

SpeakerGuard is a trademark of Texas Instruments.



These devices have limited built-in ESD protection. The leads should be shorted together or the device placed in conductive foam during storage or handling to prevent electrostatic damage to the MOS gates.

FUNCTIONAL BLOCK DIAGRAM

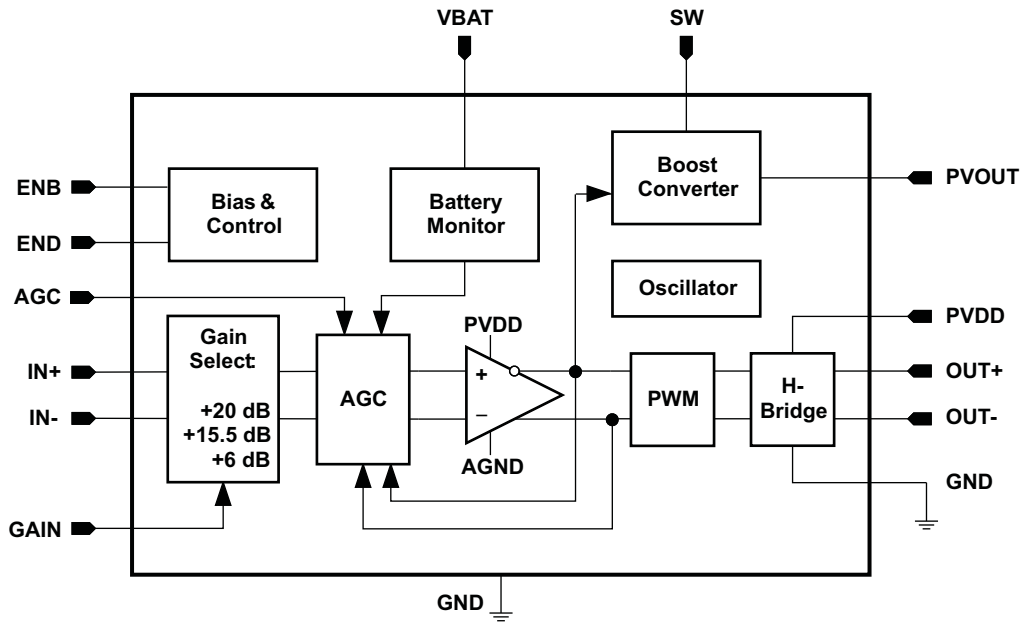

DEVICE PINOUT

WCSP (YZH) PACKAGE
(TOP VIEW)
Symbol Side

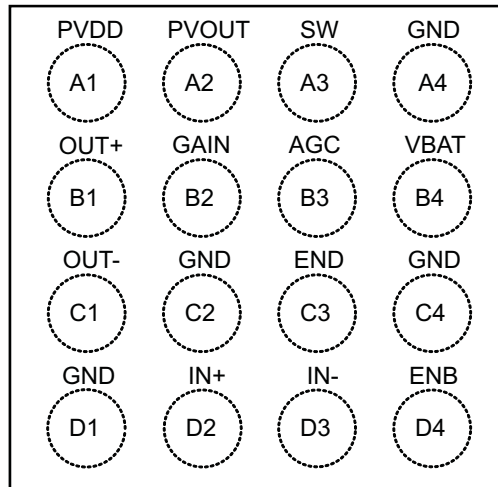

PIN FUNCTIONS

PIN		INPUT/ OUTPUT/ POWER (I/O/P)	DESCRIPTION
NAME	WCSP		
PVDD	A1	I	Class-D power stage supply voltage.
PVOUT	A2	O	Boost converter output.
SW	A3	I	Boost and rectifying switch input.
GND	A4, C2, C4, D1	P	Ground; all ground balls must be connected for proper functionality.
OUT+	B1	O	Positive audio output.
GAIN	B2	I	Gain selection pin.
AGC	B3	I	Enable and select AGC.
VBAT	B4	P	Supply voltage.
OUT–	C1	O	Negative audio output.
END	C3	I	Enable for the Class-D amplifier; set to logic high to enable.
IN+	D2	I	Positive audio input.
IN–	D3	I	Negative audio input.
ENB	D4	I	Enable for the boost converter; set to logic high to enable.

ORDERING INFORMATION

T _A	PACKAGED DEVICES ⁽¹⁾	PART NUMBER ⁽²⁾	SYMBOL
–40°C to 85°C	16-ball, 1.954mm × 1.954 mm WCSP	TPA2015D1YZHR	OEN
	16-ball, 1.954 mm × 1.954 mm WCSP	TPA2015D1YZHT	OEN

- (1) For the most current package and ordering information, see the Package Option Addendum at the end of this document, or see the TI Web site at www.ti.com.
- (2) The YZH package is only available taped and reeled. The suffix “R” indicates a reel of 3000, the suffix “T” indicates a reel of 250.

ABSOLUTE MAXIMUM RATINGS

Over operating free–air temperature range, T_A = 25°C (unless otherwise noted)⁽¹⁾

		MIN	MAX
Supply voltage	VBAT	–0.3 V	6 V
Input Voltage, V _I	IN+, IN–	–0.3 V	VBAT + 0.3 V
Output continuous total power dissipation		See the Thermal Information Table	
Operating free-air temperature range, T _A		–40°C	85°C
Operating junction temperature range, T _J		–40°C	150°C
Storage temperature range, T _{STG}		–65°C	150°C
Minimum load impedance		6 Ω	
ESD Protection	HBM		2000 V
	CDM		500 V
	MM		100 V

- (1) Stresses beyond those listed under *absolute maximum ratings* may cause permanent damage to the device. These are stress ratings only, and functional operation of the device at these or any other conditions beyond those indicated under *recommended operating conditions* is not implied. Exposure to absolute–maximum–rated conditions for extended periods may affect device reliability.

THERMAL INFORMATION

THERMAL METRIC ⁽¹⁾		TPA2015D1	UNITS
		YZH	
		16 PINS	
θ_{JA}	Junction-to-ambient thermal resistance	75	°C/W
$\theta_{JC(top)}$	Junction-to-case(top) thermal resistance	22	
θ_{JB}	Junction-to-board thermal resistance	26	
ψ_{JT}	Junction-to-top characterization parameter	0.5	
ψ_{JB}	Junction-to-board characterization parameter	25	
$\theta_{JC(bottom)}$	Junction-to-case(bottom) thermal resistance	n/a	

(1) For more information about traditional and new thermal metrics, see the *IC Package Thermal Metrics* application report, [SPRA953](#).

RECOMMENDED OPERATING CONDITIONS

		MIN	MAX	UNIT
	Supply voltage, VBAT	2.5	5.2	V
V_{IH}	High-level input voltage, END, ENB	1.3		V
V_{IL}	Low-level input voltage, END, ENB		0.6	V
T_A	Operating free-air temperature	-40	85	°C
T_J	Operating junction temperature	-40	150	°C

ELECTRICAL CHARACTERISTICS

VBAT = 3.6 V, Gain = 6 dB, R_{AGC} = Float, T_A = 25°C, R_L = 8 Ω + 33 μ H (unless otherwise noted)

PARAMETER	TEST CONDITIONS	MIN	TYP	MAX	UNIT
VBAT supply voltage range	END = 0 V, ENB = VBAT	2.5		5.2	V
	END = VBAT, ENB = VBAT, AGC options 1, 2, and 3	2.5		5.2	
	END = VBAT, ENB = VBAT, AGC option 0	2.8		5.2	
Class-D supply voltage range	END = ENB = VBAT, boost converter active	5.2		5.8	V
	END = VBAT, ENB = 0 V	3.1		5.25	V
Power supply ripple rejection	VBAT = 2.5 V to 5.2 V, END = ENB = VBAT		85		dB
	VBAT = 2.5 V to 5.2 V, END = VBAT, ENB = 0 V (pass through mode)		75		
Operating quiescent current	END = 0 V, ENB = VBAT		0.5		mA
	END = ENB = VBAT		1.7	2.2	mA
Shutdown quiescent current	VBAT = 2.5 V to 5.2 V, END = ENB = GND		0.2	3	μ A
Gain control pin voltage	Gain = 6 dB (connect to GND)	0		$0.25 \times VBAT$	V
	Gain = 15.5 dB (float)	$0.4 \times VBAT$		$0.6 \times VBAT$	
	Gain = 20 dB (connect to VBAT)	$0.75 \times VBAT$			
AGC control pin voltage	AGC with no inflection point, $R_{(AGC)}$ = Open	2			V
	AGC option 1 (inflection = 3.55 V), $R_{(AGC)}$ = 39 k Ω ($\pm 5\%$)	1.36		1.75	
	AGC option 2 (inflection = 3.78 V), $R_{(AGC)}$ = 27 k Ω ($\pm 5\%$)	0.94		1.2	
	AGC option 3 (inflection = 3.96 V), $R_{(AGC)}$ = 18 k Ω ($\pm 5\%$)	0		0.825	
AGC control pin output current		37.6	40	42.4	μ A
Input common-mode voltage range	IN+, IN-	0.6		1.3	V
Start-up time	Boost converter followed by Class-D amplifier		6	10	ms
	Boost converter only		1	4	
	Class-D amplifier only		5	6	

OPERATING CHARACTERISTICS

VBAT = 3.6 V, TA = 25°C, RL = 8 Ω + 33 μH (unless otherwise noted)

PARAMETER		TEST CONDITIONS	MIN	TYP	MAX	UNIT
BOOST CONVERTER						
V(PVOUT)	Boost converter output voltage range	I(BOOST) = 0 mA	5.4		6	V
		I(BOOST) = 700 mA		5.4		
IL	Boost converter input current limit	Power supply current		1500		mA
	Boost converter start-up current limit			450		mA
η	Boost converter efficiency	END = 0 V, I(PVOUT) = 100 mA constant		88%		
fBOOST	Boost converter frequency			1.2		MHz
CLASS-D AMPLIFIER						
PO	Output power	THD = 1%, VBAT = 2.5 V, f = 1 kHz		1200		mW
		THD = 1%, VBAT = 3 V, f = 1 kHz		1500		
		THD = 1%, VBAT = 3.6 V, f = 1 kHz		1700		
VO	Output peak voltage	THD = 1%, VBAT = 3 V, f = 1 kHz, 6 dB crest factor sine burst, no clipping		5.2		V
AV	Closed-loop voltage gain	GAIN < 0.25 × VBAT		6		dB
		0.4 × VBAT < GAIN < 0.6 × VBAT (or float)		15.5		
		GAIN > 0.75 × VBAT		20		
ΔAV	Gain accuracy		-0.5		0.5	dB
VOOS	Output offset voltage				10	mV
RIN	Input impedance (per input pin)	AV = 6 dB		27.8		kΩ
		AV = 15.5 dB		14.9		
		AV = 20 dB		10.1		
	Input impedance in shutdown (per input pin)	END = 0 V		88.4		kΩ
ZO	Output impedance in shutdown	END = 0 V		2		kΩ
fCLASS-D	Switching frequency		560	600	640	kHz
EN	Noise output voltage	A-weighted, GAIN = 6 dB		24.8		μVRMS
		A-weighted, GAIN = 15.5 dB		33.4		
		A-weighted, GAIN = 20 dB		42.4		
THD+N	Total harmonic distortion plus noise ⁽¹⁾	PO = 100 mW, f = 1 kHz		0.06%		
		PO = 500 mW, f = 1 kHz		0.07%		
AC PSRR	AC-Power supply ripple rejection (output referred)	200 mVPP ripple, f = 217 Hz		75		dB
		200 mVPP ripple, f = 4 kHz		70		
	Audio frequency passband ripple	fAUDIO = 20 Hz, CIN = 1 μF	-0.2	-0.1	0	dB
		fAUDIO = 16 kHz, CIN = 1 μF	-0.2	-0.1	0	
AUTOMATIC GAIN CONTROL						
	AGC gain range		0		20	dB
	AGC gain step size			0.5		dB
	AGC attack time (gain decrease)			0.026		ms/dB
	AGC release time (gain increase)			1600		ms/dB
	Limiter threshold voltage	VBAT > inflection point		6.15		V
	VBAT vs. Limiter slope	VBAT < inflection point		3		V/V
	AGC inflection point	AGC option 1, R(AGC) = 39 kΩ (±5%)		3.55		V
		AGC option 2, R(AGC) = 27 kΩ (±5%)		3.78		
		AGC option 3, R(AGC) = 18 kΩ (±5%)		3.96		

(1) A-weighted

TEST SET-UP FOR GRAPHS

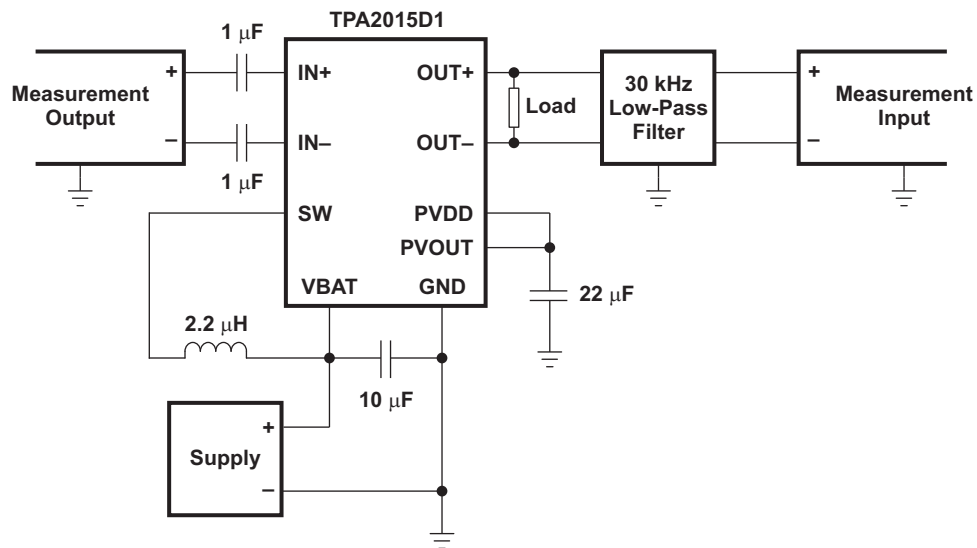

- (1) The 1 μF input capacitors (C_I) were shorted for input common-mode voltage measurements.
- (2) A 33 μH inductor was placed in series with the load resistor to emulate a small speaker for efficiency measurements.
- (3) The 30 kHz low-pass filter is required even if the analyzer has an internal low-pass filter. An R-C low pass filter (100 Ω , 47 nF) is used on each output for the data sheet graphs.

TYPICAL CHARACTERISTICS

$V_{BAT} = 3.6\text{ V}$, Gain = 6 dB, $C_1 = 1\ \mu\text{F}$, $C_{BOOST} = 22\ \mu\text{F}$, $L_{BOOST} = 2.2\ \mu\text{H}$, AGC = Float, ENB = END = V_{BAT} , and Load = $8\ \Omega + 33\ \mu\text{H}$ unless otherwise specified.

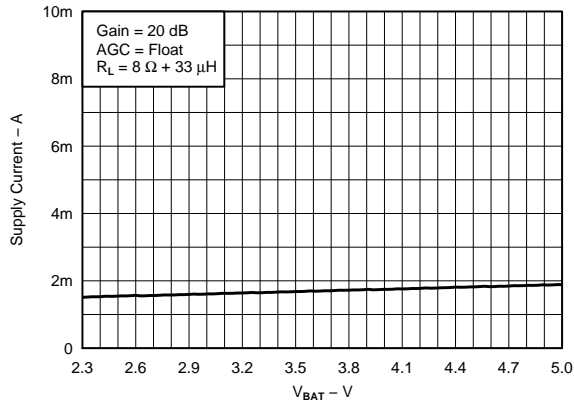

Figure 1. QUIESCENT SUPPLY CURRENT vs SUPPLY VOLTAGE

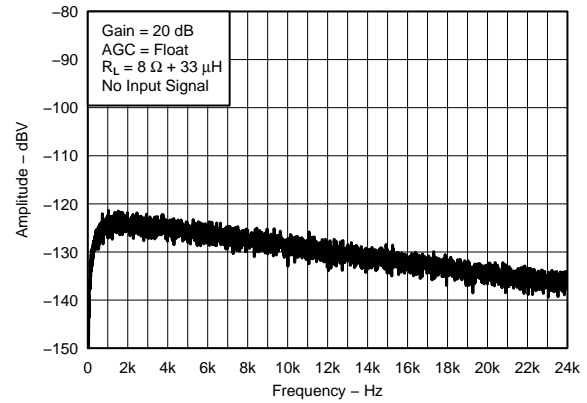

Figure 2. A-WEIGHTED OUTPUT NOISE vs FREQUENCY

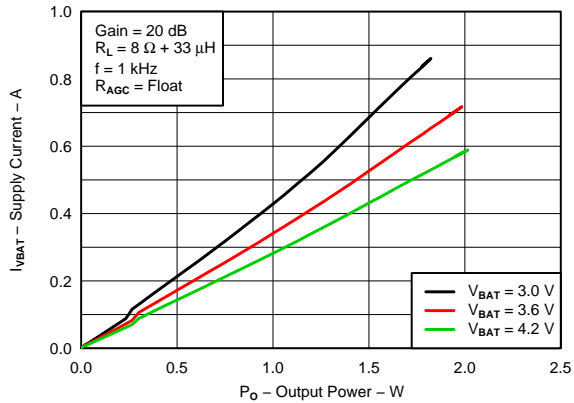

Figure 3. SUPPLY CURRENT vs OUTPUT POWER

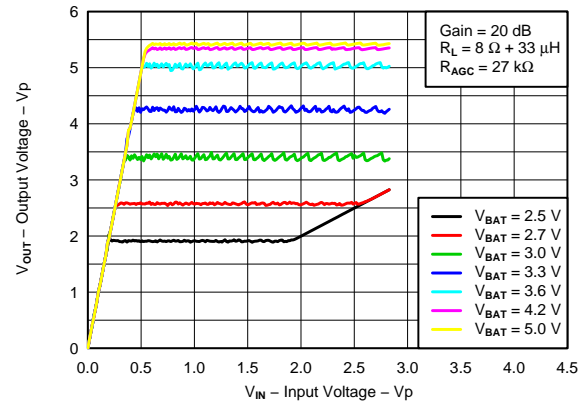

Figure 4. PEAK OUTPUT VOLTAGE vs PEAK INPUT VOLTAGE

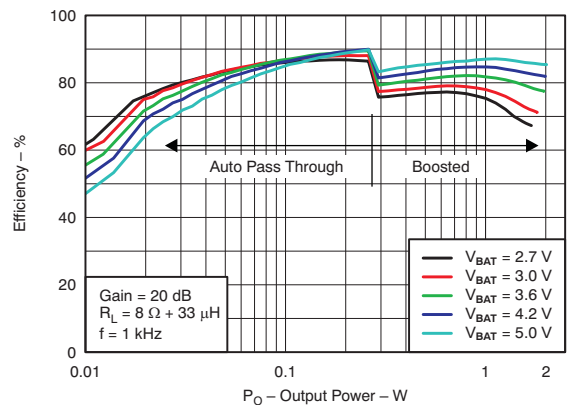

Figure 5. TOTAL EFFICIENCY vs OUTPUT POWER

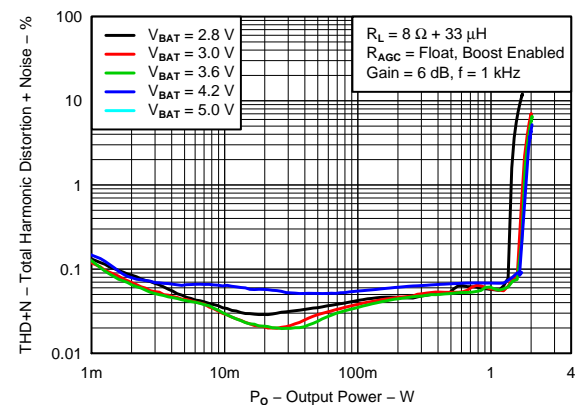

Figure 6. TOTAL HARMONIC DISTORTION + NOISE vs OUTPUT POWER

TYPICAL CHARACTERISTICS (continued)

$V_{BAT} = 3.6\text{ V}$, Gain = 6 dB, $C_1 = 1\ \mu\text{F}$, $C_{BOOST} = 22\ \mu\text{F}$, $L_{BOOST} = 2.2\ \mu\text{H}$, AGC = Float, ENB = END = V_{BAT} , and Load = $8\ \Omega + 33\ \mu\text{H}$ unless otherwise specified.

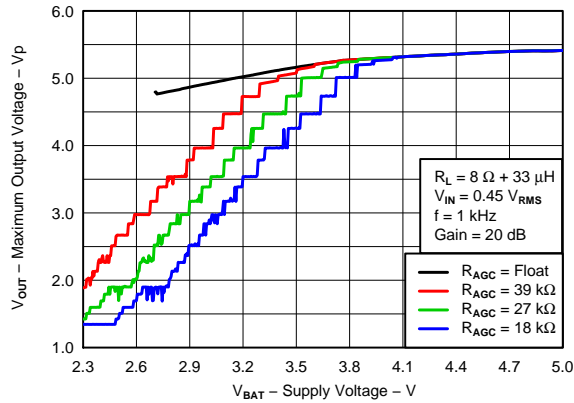

Figure 7. MAXIMUM OUTPUT VOLTAGE vs SUPPLY VOLTAGE

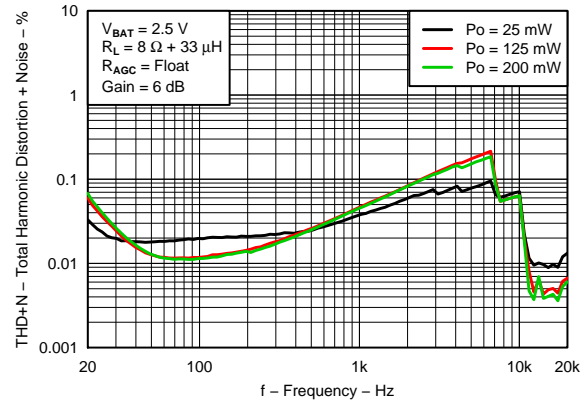

Figure 8. TOTAL HARMONIC DISTORTION + NOISE vs FREQUENCY

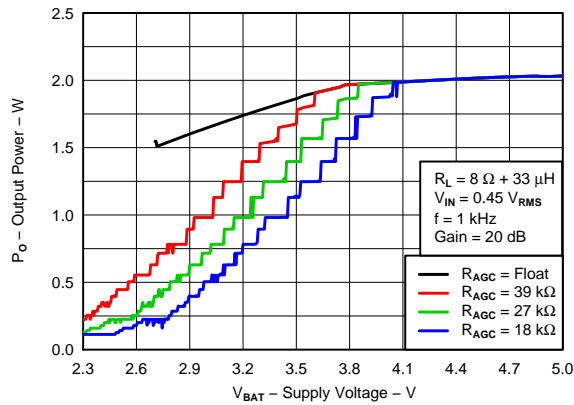

Figure 9. OUTPUT POWER vs SUPPLY VOLTAGE

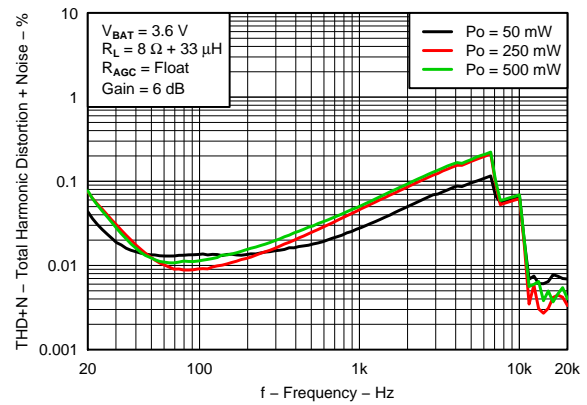

Figure 10. TOTAL HARMONIC DISTORTION + NOISE vs FREQUENCY

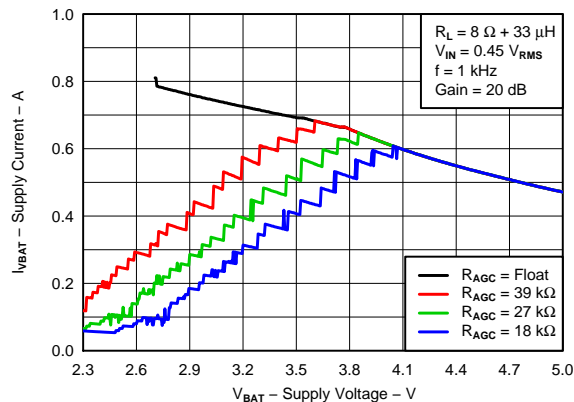

Figure 11. SUPPLY CURRENT vs SUPPLY VOLTAGE

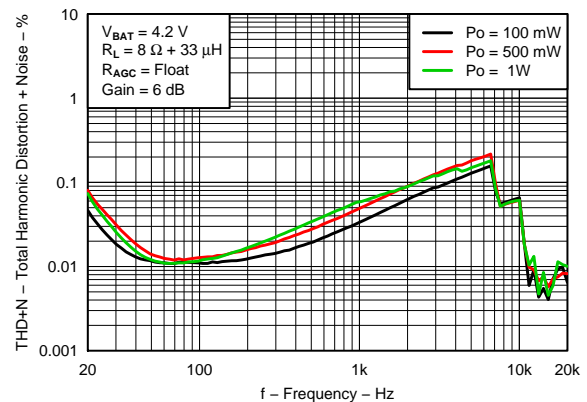

Figure 12. TOTAL HARMONIC DISTORTION + NOISE vs FREQUENCY

TYPICAL CHARACTERISTICS (continued)

$V_{BAT} = 3.6\text{ V}$, Gain = 6 dB, $C_1 = 1\ \mu\text{F}$, $C_{BOOST} = 22\ \mu\text{F}$, $L_{BOOST} = 2.2\ \mu\text{H}$, AGC = Float, ENB = END = V_{BAT} , and Load = $8\ \Omega + 33\ \mu\text{H}$ unless otherwise specified.

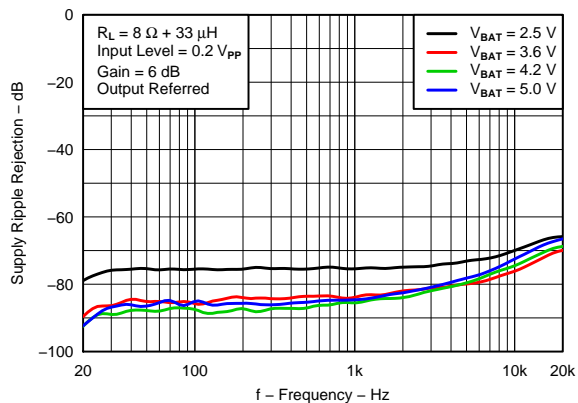

Figure 13. SUPPLY RIPPLE REJECTION vs FREQUENCY

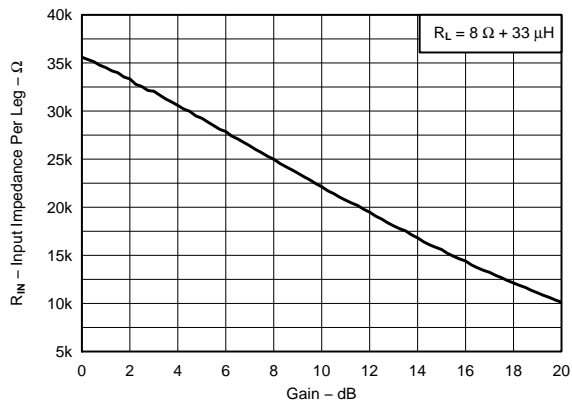

Figure 14. INPUT IMPEDANCE (PER INPUT) vs GAIN

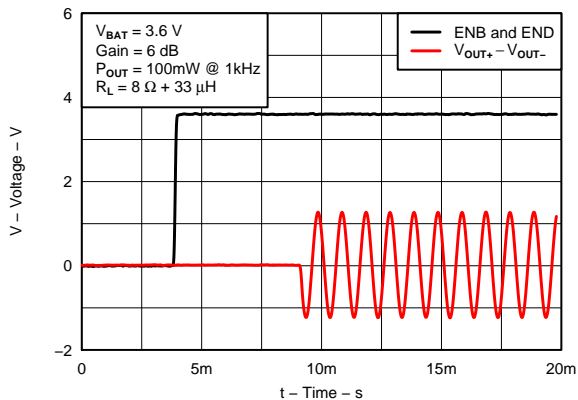

Figure 15. STARTUP TIMING

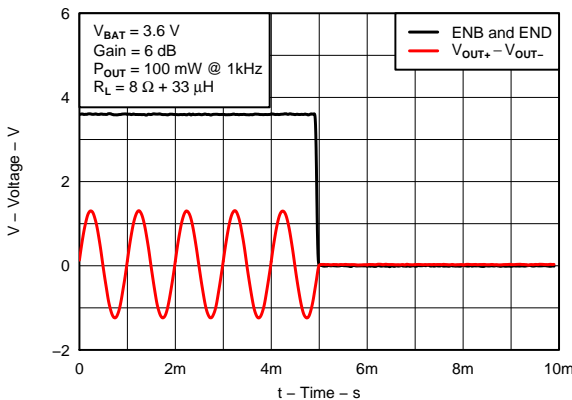

Figure 16. SHUTDOWN TIMING

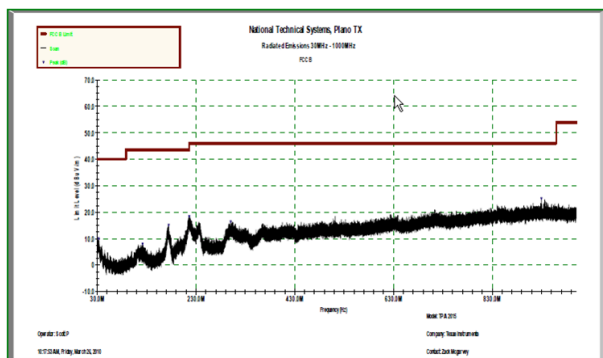

Figure 17. EMC PERFORMANCE
 $P_O = 50\text{ mW}$ with 2 INCH SPEAKER CABLE

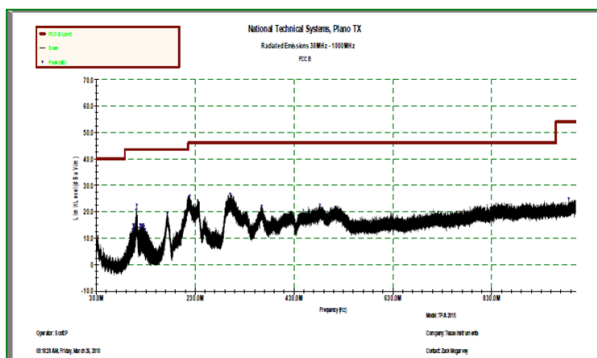

Figure 18. EMC PERFORMANCE
 $P_O = 750\text{ mW}$ with 2 INCH SPEAKER CABLE

APPLICATION INFORMATION

APPLICATION CIRCUIT

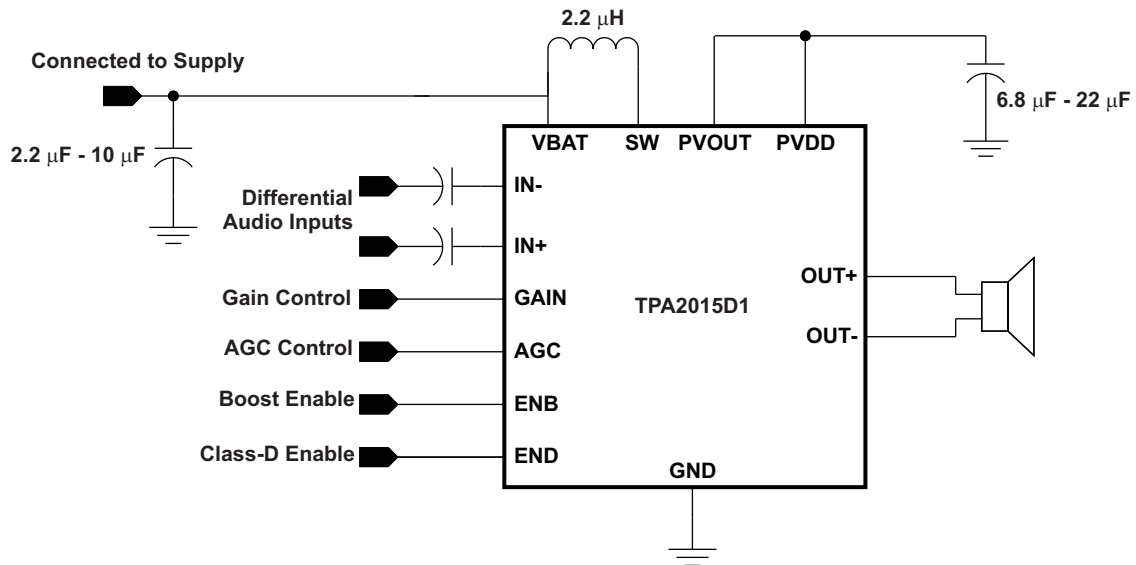

Figure 19. Typical Application Schematic with Differential Input Signals

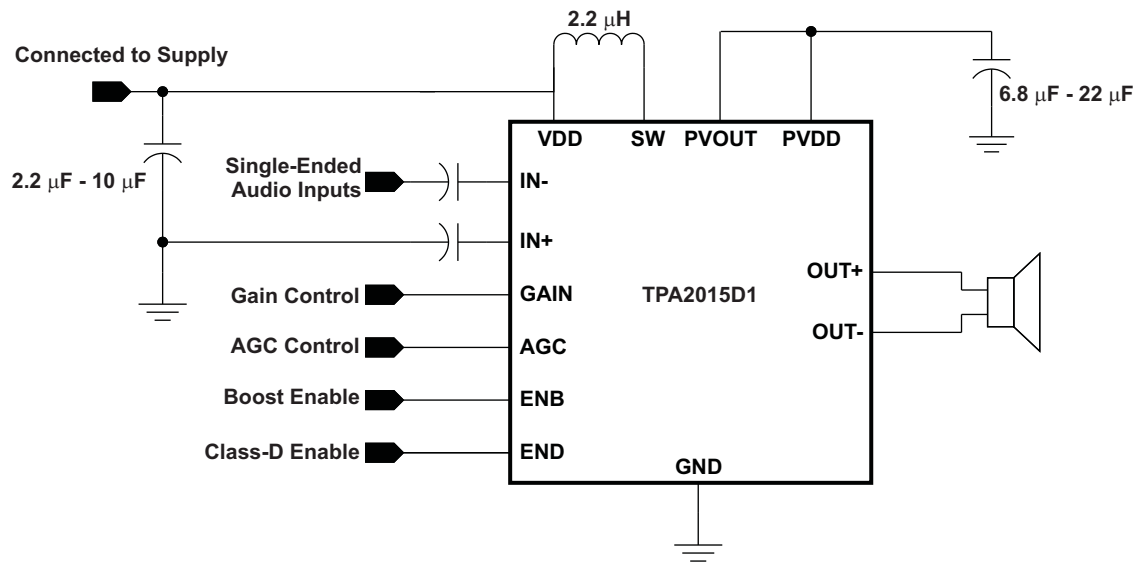

Figure 20. Typical Application Schematic with Single-Ended Input Signals

GLOSSARY

The application section uses the following terms:

Limiter level	The maximum output voltage allowed before amplifier gain is automatically reduced.
SpeakerGuard™	TI's trademark name for the automatic gain control technology. It protects speakers by limiting maximum output power.
Inflection point	The battery voltage threshold for reducing the limiter level. If the battery voltage drops below the inflection point, the limiter level automatically reduces. Although it lowers the maximum output power, it prevents high battery currents at end-of-charge low battery voltages.
Battery track	The name for the continuous limiter level reduction at battery voltages below the inflection point.
AGC	Automatic gain control.
VBAT	The battery supply voltage to the TPA2015D1. The VBAT pin is the input to the boost converter.
Fixed-gain	The nominal audio gain as set by the GAIN pin. If the audio output voltage remains below the limiter level, the amplifier gain will return to the fixed-gain.
Attack time	The rate of AGC gain decrease. The attack time is constant at 0.026 ms/dB.
Release time	The rate of AGC gain increase. The release time is constant at 1600 ms/dB.

SPEAKERGUARD™ THEORY OF OPERATION

SpeakerGuard™ protects speakers, improves loudness, and limits peak supply current. If the output audio signal exceeds the limiter level, then SpeakerGuard™ decreases amplifier gain. The rate of gain decrease, the attack time, is fixed at 0.026 ms/dB. SpeakerGuard™ increases the gain once the output audio signal is below the limiter level. The rate of gain increase, the release time, is fixed at 1600 ms/dB. [Figure 21](#) shows this relationship.

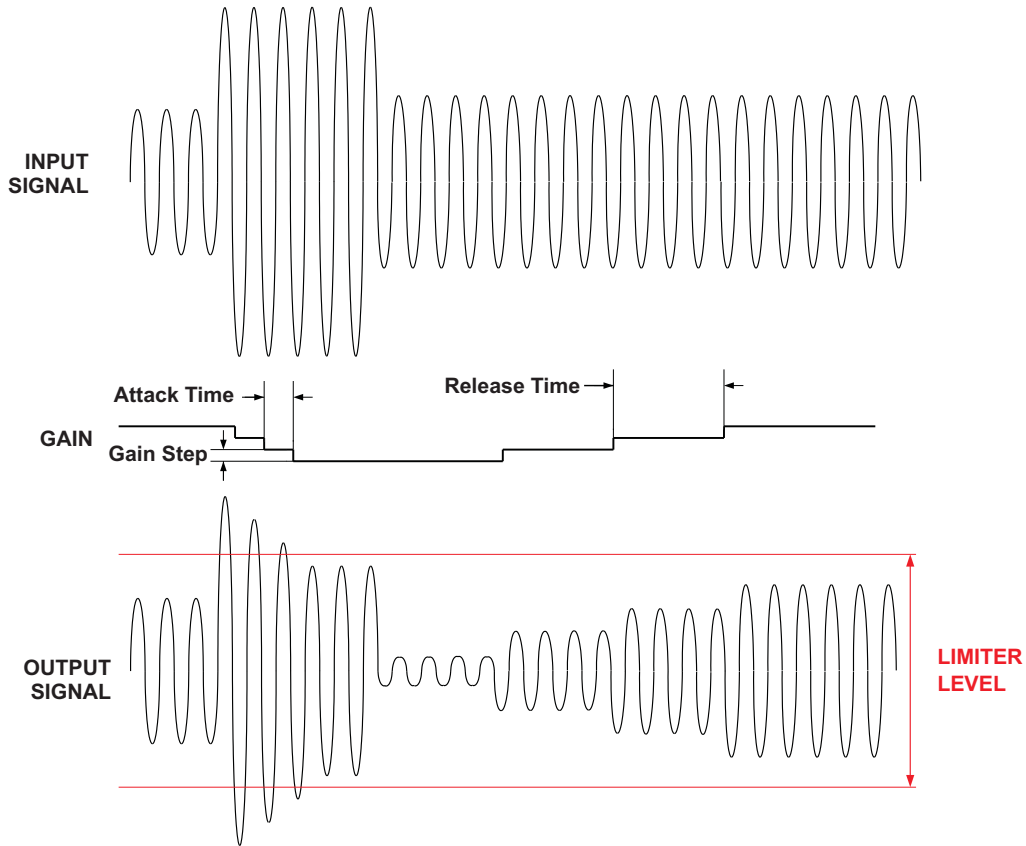

Figure 21. SpeakerGuard Attack and Release Times

BATTERY TRACKING SPEAKERGUARD™

The TPA2015D1 monitors the battery voltage and the audio signal, automatically decreasing gain when battery voltage is low and audio output power is high. It finds the optimal gain to maximize loudness and minimize battery current, providing louder audio and preventing early shutdown at end-of-charge battery voltages. SpeakerGuard decreases amplifier gain when the audio signal exceeds the limiter level. The limiter level automatically decreases when the supply voltage (VBAT) is below the inflection point. Figure 22 shows a plot of the limiter level as a function of the supply voltage.

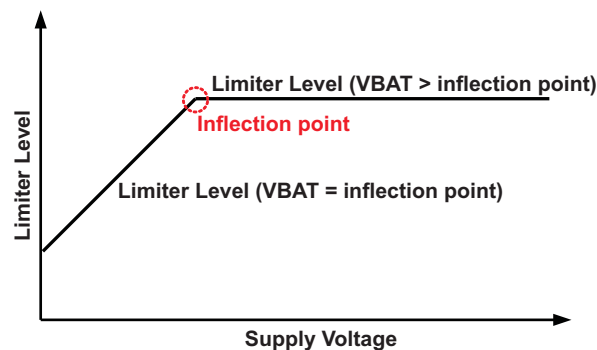

Figure 22. Limiter Level vs Supply Voltage

The limiter level decreases within 60 μ s of the supply voltage dropping below the inflection point. Although this is slightly slower than the 26 μ s/dB SpeakerGuard attack time, the difference is audibly imperceptible.

Connect a resistor between the AGC pin and ground to set the inflection point, as shown in [Table 1](#). Leave the AGC pin floating to disable the inflection point, keeping the limiter level constant over all supply voltages.

The maximum limiter level is fixed, as is the slope of the limiter level versus supply voltage. If different values for maximum limiter level and slope are required, contact your local Texas Instruments representative.

Table 1. AGC Function Table

Function	Resistor on AGC pin	Inflection Point
Constant limiter level; battery track OFF	Floating or connected to VBAT	disabled
AGC battery track option 1	39 k Ω	3.55 V
AGC battery track option 2	27 k Ω	3.78 V
AGC battery track option 3	18 k Ω	3.96 V

The audio signal is not affected by the SpeakerGuard™ function unless the peak audio output voltage exceeds the limiter level. [Figure 23](#) shows the relationship between the audio signal, the limiter level, the supply voltage, and the supply current.

When VBAT is greater than the inflection point, the limiter level allows the output signal to slightly clip to roughly 6% THD at 2 W into 8 Ω . This is an acceptable peak distortion level for most small-sized portable speakers, while ensuring maximum loudness from the speaker.

Battery Tracking SpeakerGuard™ Example

Phase 1 Battery discharging normally; supply voltage is above inflection point; audio output remains below limiter level.

The limiter level remains constant because the supply voltage is greater than the inflection point. Amplifier gain is constant at fixed-gain as set by the GAIN pin. The audio output remains at a constant loudness. The boost converter allows the audio output to swing above the battery supply voltage. Battery supply current increases as supply voltage decreases.

Phase 2 Battery continues to discharge normally; supply voltage decreases below inflection point; limiter level decreases below audio output.

The limiter level decreases as the battery supply voltage continues to decrease. SpeakerGuard™ lowers amplifier gain, reducing the audio output below the new limiter level. The supply current decreases due to reduced output power.

Phase 3 Battery supply voltage is constant; audio output remains below limiter level.

The audio output, limiter level, and supply current remain constant as well.

Phase 4 Phone plugged in and battery re-charges; supply voltage increases.

The limiter level increases as the supply voltage increases. SpeakerGuard™ increases amplifier gain slowly, increasing audio output. Because the TPA2015D1 supply current is proportional to the PVOUT-to-VBAT ratio, the supply current decreases as battery supply voltage increases.

Phase 5 Battery supply voltage is constant; audio output is below limiter level.

SpeakerGuard™ continues to increase amplifier gain to the fixed-gain as set by the GAIN pin. The audio output signal increases (slowly due to release time) to original value.

Phase 6 Battery supply voltage is constant; audio output remains below limiter level.

Amplifier gain equal to fixed-gain as set by the GAIN pin. Audio output signal does not change. Supply current remains constant.

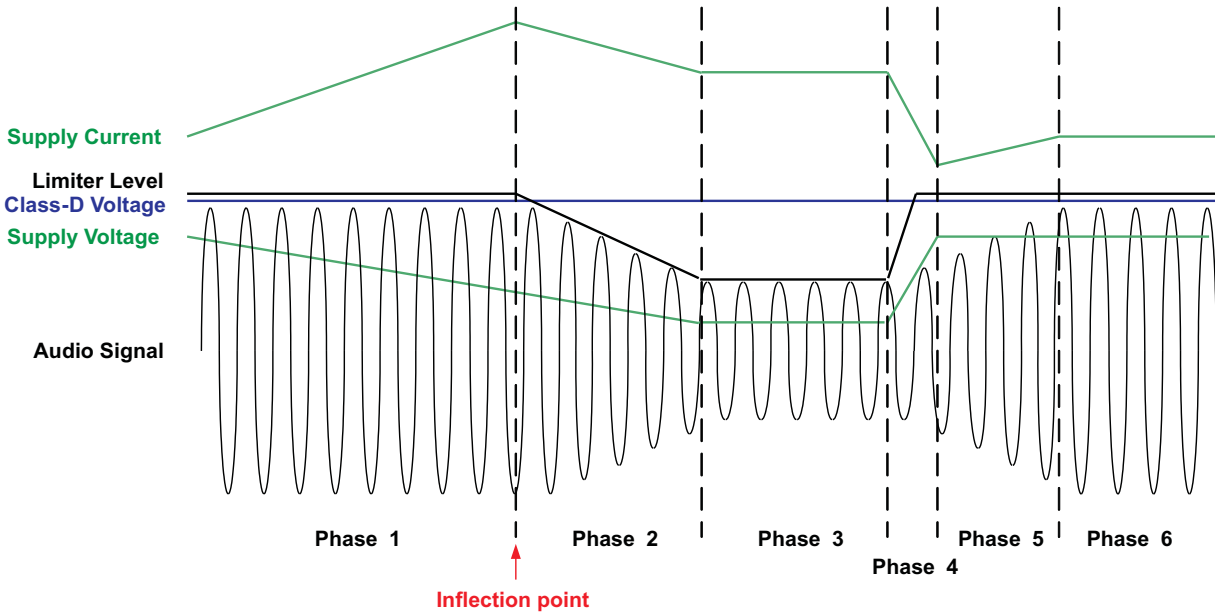

Figure 23. Relationship Between Supply Voltage, Current, Limiter Level, and Output Audio Signal

SpeakerGuard with Varying Input Levels

SpeakerGuard protects speakers by decreasing gain during large output transients. Figure 24 shows the maximum output voltage at different input voltage levels. The load is 8 Ω and the gain is 15.5 dB (6 V/V).

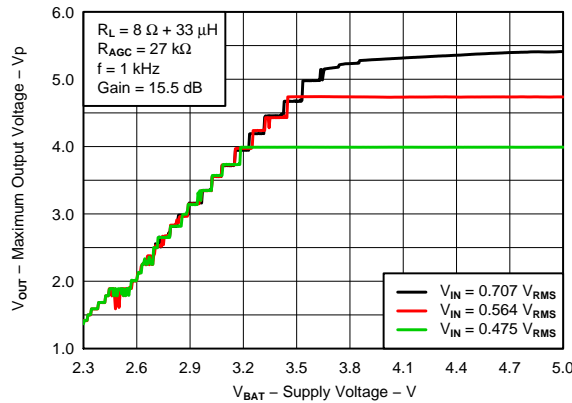

Figure 24. MAXIMUM OUTPUT VOLTAGE vs SUPPLY VOLTAGE

A 0.707 V_{RMS} sine-wave input signal forces the output voltage to 4.242 V_{RMS} , or 6.0 V_{PEAK} . Above 3.9 V supply, the boost converter voltage sags due to high output current, resulting in a peak Class-D output voltage of about 5.4 V. As the supply voltage decreases below 3.9 V, the limiter level decreases. This causes the gain to decrease, and the peak Class-D output voltage lowers.

With a 0.564 V_{RMS} input signal, the peak Class-D output voltage is 4.78 V. When the supply voltage is above 3.45 V, the output voltage remains below the limiter level, and the gain stays at 15.5 dB. Once the supply drops below 3.45 V, the limiter level decreases below 4.78 V, and SpeakerGuard decreases the gain.

The same rationale applies to the 0.475 V_{RMS} input signal. Although the supply voltage may be below the inflection point, audio gain does not decrease until the Class-D output voltage is above the limiter level.

SPEAKER LOAD LIMITATION

Speakers are non-linear loads with varying impedance (magnitude and phase) over the audio frequency. A portion of speaker load current can flow back into the boost converter output via the Class-D output H-bridge high-side device. This is dependent on the speaker's phase change over frequency, and the audio signal amplitude and frequency content.

Most portable speakers have limited phase change at the resonant frequency, typically no more than 40 or 50 degrees. To avoid excess flow-back current, use speakers with limited phase change. Otherwise, flow-back current could exceed the 10 mA rating of the boost converter voltage clamp and drive the PVOOUT voltage above the absolute maximum recommended operational voltage.

Confirm proper operation by connecting the speaker to the TPA2015D1 and driving it at maximum output swing. Observe the PVOOUT voltage with an oscilloscope. In the unlikely event the PVOOUT voltage exceeds 6.5 V, add a 6.8 V Zener diode between PVOOUT and ground to ensure the TPA2015D1 operates properly.

The amplifier has thermal overload protection and deactivates if the die temperature exceeds 150°C. It automatically reactivates once die temperature returns below 150°C. Built-in output over-current protection deactivates the amplifier if the speaker load becomes short-circuited. The amplifier automatically restarts within 200 ms after the over-current event. Although the TPA2015D1 Class-D output can withstand a short between OUT+ and OUT-, do not connect either output directly to GND, PVDD, or VBAT as this could damage the device.

WARNING

Do not connect OUT+ or OUT- directly to GND, PVDD, or VBAT as this could damage the Class-D output stage.

FULLY DIFFERENTIAL CLASS-D AMPLIFIER

The TPA2015D1 uses a fully differential amplifier with differential inputs and outputs. The differential output voltage equals the differential input multiplied by the amplifier gain. The TPA2015D1 can also be used with a single-ended input. However, using differential input signals when in a noisy environment, like a wireless handset, ensures maximum system noise rejection.

Advantages of Fully Differential Amplifiers

- Mid-supply bypass capacitor, C_{BYPASS} , not required:
 - The fully differential amplifier does not require a mid-supply bypass capacitor. Any shift in the mid-supply affects both positive and negative channels equally and cancels at the differential output.
- Improved RF-immunity:
 - GSM handsets save power by turning on and shutting off the RF transmitter at a rate of 217 Hz. This 217 Hz burst often couples to audio amplifier input and output traces causing frame-rate noise. Fully differential amplifiers cancel frame-rate noise better than non-differential amplifiers.
- Input-coupling capacitors not required, but recommended:
 - The fully differential amplifier allows the inputs to be biased at voltages other than mid-supply ($PVDD/2$). The TPA2015D1 inputs can be biased anywhere within the common mode input voltage range, as listed in the [OPERATING CHARACTERISTICS](#) table. If the inputs are biased outside of that range, then input-coupling capacitors are required.
 - Note that without input coupling capacitors, any dc offset from the audio source will be modulated by the AGC. This could cause artifacts in the audio output signal. Perform listening tests to determine if direct input coupling is acceptable.

The TPA2015D1 has 3 selectable fixed-gains: 6 dB, 15.5 dB, and 20 dB. Connect the GAIN pin as shown in [Table 2](#).

Table 2. Amplifier Fixed-Gain

Connect GAIN Pin to	Amplifier Gain
GND	6 dB
No Connection (Floating)	15.5 dB
VBAT	20 dB

Improved Class-D Efficiency

The TPA2015D1 output stage uses a modulation technique that modulates the PWM output only on one side of the differential output, leaving the other side held at ground. Although the differential output voltage is undistorted, each output appears as a half-wave rectified signal.

This technique reduces output switching losses and improves overall amplifier efficiency. [Figure 25](#) shows how $OUT+$, $OUT-$, and the differential output voltages appear on an oscilloscope.

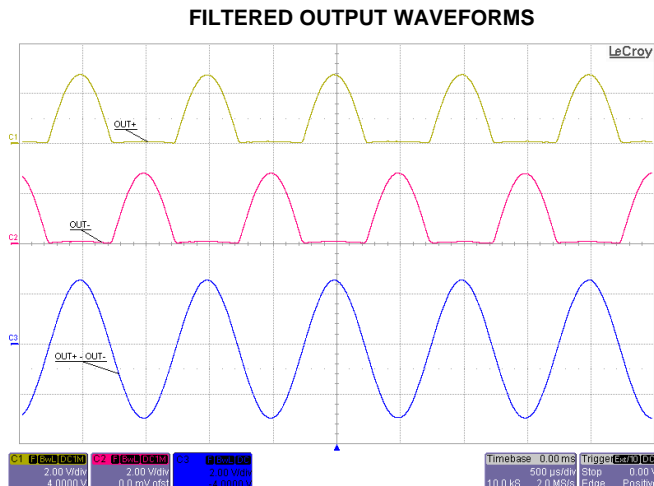

Figure 25.

ADAPTIVE BOOST CONVERTER

The TPA2015D1 consists of an adaptive boost converter and a Class-D amplifier. The boost converter takes the supply voltage, VBAT, and increases it to a higher output voltage, PVOOUT. PVOOUT drives the supply voltage of the Class-D amplifier, PVDD. This improves loudness over non-boosted solutions.

The boost converter is adaptive and activates automatically depending on the output audio signal amplitude. When the peak output audio signal exceeds a preset voltage threshold, the boost converter is enabled, and the voltage at PVOOUT is 5.5 V. When the audio output voltage is lower than the threshold voltage, the boost deactivates automatically. The boost activation threshold voltage is not user programmable. It is optimized to prevent clipping while maximizing system efficiency.

The boost converter can be forcibly deactivated by setting the ENB pin to logic-low. When the boost is deactivated, PVOOUT is equal to the supply voltage (VBAT) minus the $I \times R$ drop across the inductor and boost converter pass transistor.

A timer prevents the input signal from modulating the PVOOUT voltage within the audio frequency range, eliminating the potential for audible artifacts on the Class-D output.

Figure 26 shows how the adaptive boost modulates with a typical audio signal. By automatically deactivating the boost converter and passing VBAT to PVOOUT, the TPA2015D1 efficiency is improved at low output power.

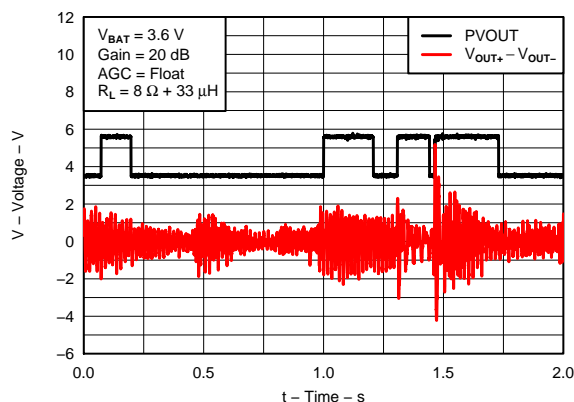

Figure 26. ADAPTIVE BOOST CONVERTER with TYPICAL MUSIC PLAYBACK

The primary external components for the boost converter are the inductor and the boost capacitor. The inductor stores current, and the boost capacitor stores charge. As the Class-D amplifier depletes the charge in the boost capacitor, the boost inductor replenishes charge with its stored current. The cycle of charge and discharge occurs frequently enough to keep PVOOUT within its minimum and maximum voltage specification.

The boost converter design is optimized for driving the integrated Class-D amplifier only. It lacks protection circuitry recommended for driving loads other than the integrated Class-D amplifier.

Boost Converter Overvoltage Protection

The TPA2015D1 internal boost converter operates in a discontinuous mode to improve the efficiency at light loads. The boost converter has overvoltage protection that disables the boost converter if the output voltage exceeds 5.8 V. If current is forced into the PVOOUT terminal, the voltage clamp will sink up to 10 mA. If more than 10 mA is forced into PVOOUT, then the PVOOUT voltage will increase. Refer to the [SPEAKER LOAD LIMITATION](#) section for details.

Boost Converter Component Section

Boost Terms

The following is a list of terms and definitions used in the boost equations found later in this document.

C	Minimum boost capacitance required for a given ripple voltage on PVOOUT.
L	Boost inductor.
f_{BOOST}	Switching frequency of the boost converter.
I_{PVDD}	Current pulled by the Class-D amplifier from the boost converter.
I_L	Average current through the boost inductor.
PVDD (PVOOUT)	Supply voltage for the Class-D amplifier. (Voltage generated by the boost converter output.)
VBAT	Supply voltage to the IC.
ΔI_L	Ripple current through the inductor.
ΔV	Ripple voltage on PVOOUT.

Boost Converter Inductor Selection

Working inductance decreases as inductor current and temperature increases. If the drop in working inductance is severe enough, it may cause the boost converter to become unstable, or cause the TPA2015D1 to reach its current limit at a lower output voltage than expected. Inductor vendors specify currents at which inductor values decrease by a specific percentage. This can vary by 10% to 35%. Inductance is also affected by dc current and temperature.

Inductor Equations

Inductor current rating is determined by the requirements of the load. The inductance is determined by two factors: the minimum value required for stability and the maximum ripple current permitted in the application.

Use [Equation 1](#) to determine the required current rating. [Equation 1](#) shows the approximate relationship between the average inductor current, I_L , to the load current, load voltage, and input voltage (I_{PVDD} , PVDD, and VBAT, respectively). Insert I_{PVDD} , PVDD, and VBAT into Equation 1 and solve for I_L . The inductor must maintain at least 90% of its initial inductance value at this current.

$$I_L = I_{\text{PVDD}} \times \left(\frac{\text{PVDD}}{\text{VBAT} \times 0.8} \right) \quad (1)$$

WARNING

Use a minimum working inductance of 1.3 μH . Lower values may damage the inductor.

Ripple current, ΔI_L , is peak-to-peak variation in inductor current. Smaller ripple current reduces core losses in the inductor and reduces the potential for EMI. Use [Equation 2](#) to determine the value of the inductor, L. [Equation 2](#) shows the relationship between inductance L, VBAT, PVDD, the switching frequency, f_{BOOST} , and ΔI_L . Insert the maximum acceptable ripple current into [Equation 2](#) and solve for L.

$$L = \frac{V_{\text{BAT}} \times (P_{\text{VDD}} - V_{\text{BAT}})}{\Delta I_L \times f_{\text{BOOST}} \times P_{\text{VDD}}} \quad (2)$$

ΔI_L is inversely proportional to L. Minimize ΔI_L as much as is necessary for a specific application. Increase the inductance to reduce the ripple current. Do not use greater than 4.7 μH , as this prevents the boost converter from responding to fast output current changes properly. If using above 3.3 μH , then use at least 10 μF capacitance on PVOU to ensure boost converter stability.

The typical inductor value range for the TPA2015D1 is 2.2 μH to 3.3 μH . Select an inductor with less than 0.5 Ω dc resistance, DCR. Higher DCR reduces total efficiency due to an increase in voltage drop across the inductor.

Table 3. Sample Inductors

L (μH)	SUPPLIER	COMPONENT CODE	SIZE (L×W×H mm)	DCR TYP (m Ω)	I _{SAT} MAX (A)	C RANGE
2.2	Chilisin Electronics Corp.	CLCN252012T-2R2M-N	2.5 x 2.0 x 1.2	105	1.2	4.7 – 22 μF / 16 V 6.8 – 22 μF / 10 V
2.2	Toko	1239AS-H-2R2N=P2	2.5 x 2.0 x 1.2	96	2.3	
2.2	Coilcraft	XFL4020-222MEC	4.0 x 4.0 x 2.15	22	3.5	
3.3	Toko	1239AS-H-3R3N=P2	2.5 x 2.0 x 1.2	160	2.0	10 – 22 μF / 10 V
3.3	Coilcraft	XFL4020-332MEC	4.0 x 4.0 x 2.15	35	2.8	

Boost Converter Capacitor Selection

The value of the boost capacitor is determined by the minimum value of working capacitance required for stability and the maximum voltage ripple allowed on PVDD in the application. Working capacitance refers to the available capacitance after derating the capacitor value for DC bias, temperature, and aging.

Do not use any component with a working capacitance less than 4.7 μF . This corresponds to a 4.7 μF / 16 V capacitor, or a 6.8 μF / 10 V capacitor. Do not use above 22 μF capacitance as it will reduce the boost converter response time to large output current transients.

[Equation 3](#) shows the relationship between the boost capacitance, C, to load current, load voltage, ripple voltage, input voltage, and switching frequency (I_{PVDD} , PVDD, ΔV , VBAT, and f_{BOOST} respectively).

Insert the maximum allowed ripple voltage into [Equation 3](#) and solve for C. The 1.5 multiplier accounts for capacitance loss due to applied dc voltage and temperature for X5R and X7R ceramic capacitors.

$$C = 1.5 \times \frac{I_{\text{PVDD}} \times (P_{\text{VDD}} - V_{\text{BAT}})}{\Delta V \times f_{\text{BOOST}} \times P_{\text{VDD}}} \quad (3)$$

COMPONENTS LOCATION AND SELECTION

Decoupling Capacitors

The TPA2015D1 is a high-performance Class-D audio amplifier that requires adequate power supply decoupling. Adequate power supply decoupling to ensure that the efficiency is high and total harmonic distortion (THD) is low.

Place a low equivalent-series-resistance (ESR) ceramic capacitor, typically 0.1 μF , within 2 mm of the VBAT ball. This choice of capacitor and placement helps with higher frequency transients, spikes, or digital hash on the line. Additionally, placing this decoupling capacitor close to the TPA2015D1 is important, as any parasitic resistance or inductance between the device and the capacitor causes efficiency loss. In addition to the 0.1 μF ceramic capacitor, place a 2.2 μF to 10 μF capacitor on the VBAT supply trace. This larger capacitor acts as a charge reservoir, providing energy faster than the board supply, thus helping to prevent any droop in the supply voltage.

Input Capacitors

Input audio DC decoupling capacitors are recommended. The input audio DC decoupling capacitors prevents the AGC from changing the gain due to audio DAC output offset. The input capacitors and TPA2015D1 input impedance form a high-pass filter with the corner frequency, f_c , determined in [Equation 4](#).

Any mismatch in capacitance between the two inputs will cause a mismatch in the corner frequencies. Severe mismatch may also cause turn-on pop noise. Choose capacitors with a tolerance of $\pm 10\%$ or better.

$$f_c = \frac{1}{(2 \times \pi \times R_I C_I)} \quad (4)$$

EFFICIENCY AND THERMAL INFORMATION

It is important to operate the TPA2015D1 at temperatures lower than its maximum operating temperature. The maximum ambient temperature depends on the heat-sinking ability of the PCB system. The derating factor for the package is shown in the dissipation rating table. Converting this to θ_{JA} for the WCSP package:

$$\theta_{JA} = \frac{1}{\text{Derating Factor}} = \frac{1}{0.0065} = 153^\circ\text{C/W} \quad (5)$$

Given θ_{JA} of 153°C/W , the maximum allowable junction temperature of 150°C , and the internal dissipation of 0.34 W for 1.7 W, 8 Ω load, 3.6 V supply, the maximum ambient temperature is calculated as:

$$\theta_{JA\text{MAX}} = T_{J\text{MAX}} = \theta_{JA} P_{D\text{max}} = 150 - 153(0.34) = 97.98^\circ\text{C} \quad (6)$$

[Equation 6](#) shows that the calculated maximum ambient temperature is 98°C at maximum power dissipation with at 3.6 V supply and 8 Ω a load. The TPA2015D3 is designed with thermal protection that turns the device off when the junction temperature surpasses 150°C to prevent damage to the IC.

OPERATION WITH DACS AND CODECS

Large ripple voltages can be present at the output of $\Delta\Sigma$ DACs and CODECs, just above the audio frequency (e.g: 80 kHz with a 300 mV_{PP}). This out-of-band noise is due to the noise shaping of the delta-sigma modulator in the DAC.

Some Class-D amplifiers have higher output noise when used in combination with these DACs and CODECs. This is because out-of-band noise from the CODEC/DAC mixes with the Class-D switching frequencies in the audio amplifier input stage.

The TPA2015D1 has a built-in low-pass filter that reduces the out-of-band noise and RF noise, filtering out-of-band frequencies that could degrade in-band noise performance. This built-in filter also prevents AGC errors due to out-of-band noise. The TPA2015D1 AGC calculates gain based on input signal amplitude only.

If driving the TPA2015D1 input with 4th-order or higher $\Delta\Sigma$ DACs or CODECs, add an R-C low pass filter at each of the audio inputs (IN+ and IN-) of the TPA2015D1 to ensure best performance. The recommended resistor value is 100 Ω and the capacitor value of 47 nF.

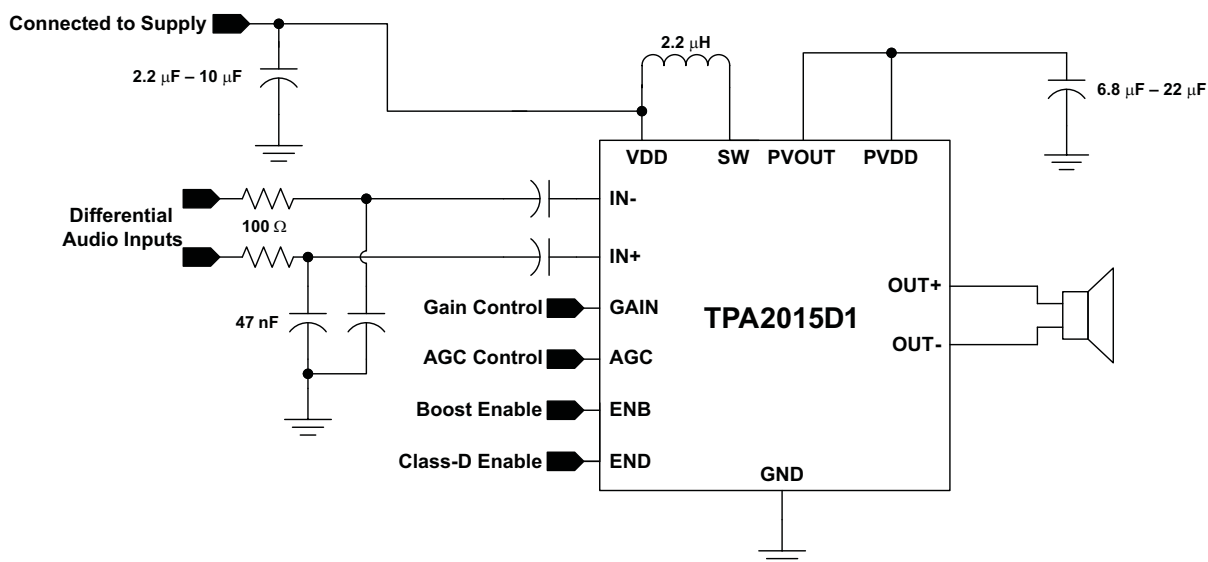

Figure 27. Reducing Out-of-Band DAC Noise with External Input Filter

FILTER FREE OPERATION AND FERRITE BEAD FILTERS

The TPA2015D1 is designed to minimize RF emissions. For more information about RF emissions and filtering requirements, See [SLOA145](#) for further information.

PACKAGE DIMENSIONS

The TPA2015D1 uses a 16-ball, 0.5 mm pitch WCSP package. The die length (D) and width (E) correspond to the package mechanical drawing at the end of the datasheet.

Table 4. Package Dimensions

Dimension	D	E
Max	1984 μm	1984 μm
Typ	1954 μm	1954 μm
Min	1924 μm	1924 μm

BOARD LAYOUT

In making the pad size for the WCSP balls, it is recommended that the layout use nonsolder mask defined (NSMD) land.

With this method, the solder mask opening is made larger than the desired land area, and the opening size is defined by the copper pad width. [Figure 28](#) and [Table 5](#) show the appropriate diameters for a WCSP layout.

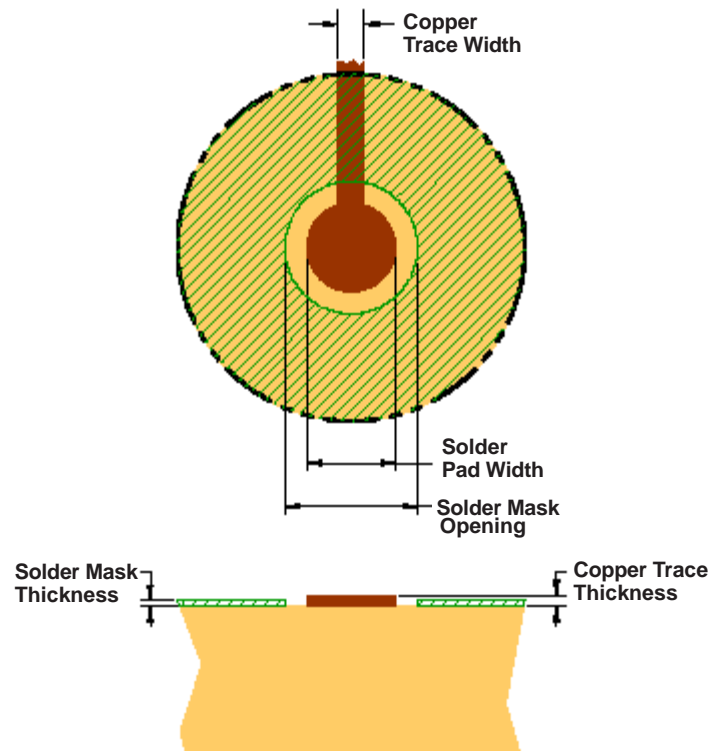

Figure 28. Land Pattern Dimensions

Table 5. Land Pattern Dimensions^{(1) (2) (3) (4)}

SOLDER PAD DEFINITIONS	COPPER PAD	SOLDER MASK ⁽⁵⁾ OPENING	COPPER THICKNESS	STENCIL ^{(6) (7)} OPENING	STENCIL THICKNESS
Nonsolder mask defined (NSMD)	275 μm (+0.0, -25 μm)	375 μm (+0.0, -25 μm)	1 oz max (32 μm)	275 μm x 275 μm Sq. (rounded corners)	125 μm thick

- (1) Circuit traces from NSMD defined PWB lands should be 75 μm to 100 μm wide in the exposed area inside the solder mask opening. Wider trace widths reduce device stand off and impact reliability.
- (2) Best reliability results are achieved when the PWB laminate glass transition temperature is above the operating range of the intended application.
- (3) Recommend solder paste is Type 3 or Type 4.
- (4) For a PWB using a Ni/Au surface finish, the gold thickness should be less than 0.5 μm to avoid a reduction in thermal fatigue performance.
- (5) Solder mask thickness should be less than 20 μm on top of the copper circuit pattern
- (6) Best solder stencil performance is achieved using laser cut stencils with electro polishing. Use of chemically etched stencils results in inferior solder paste volume control.
- (7) Trace routing away from WCSP device should be balanced in X and Y directions to avoid unintentional component movement due to solder wetting forces.

TRACE WIDTH

Recommended trace width at the solder balls is 75 μm to 100 μm to prevent solder wicking onto wider PCB traces. For high current pins (SW, GND, OUT+, OUT-, PVOU, and PVDD) of the TPA2015D1, use 100 μm trace widths at the solder balls and at least 500 μm PCB traces to ensure proper performance and output power for the device. For low current pins (IN-, IN+, END, ENB, GAIN, AGC, VBAT) of the TPA2015D1, use 75 μm to 100 μm trace widths at the solder balls. Run IN- and IN+ traces side-by-side (and if possible, same length) to maximize common-mode noise cancellation.

REVISION HISTORY

Changes from Original (May 2010) to Revision A	Page
• Changed the Boost Converter, PVOOUT entry in the Operating Conditions Table	5

PACKAGING INFORMATION

Orderable Device	Status (1)	Package Type	Package Drawing	Pins	Package Qty	Eco Plan (2)	Lead/Ball Finish	MSL Peak Temp (3)	Op Temp (°C)	Top-Side Markings (4)	Samples
TPA2015D1YZHR	ACTIVE	DSBGA	YZH	16	3000	Green (RoHS & no Sb/Br)	SNAGCU	Level-1-260C-UNLIM	-40 to 85	OEN	Samples
TPA2015D1YZHT	ACTIVE	DSBGA	YZH	16	250	Green (RoHS & no Sb/Br)	SNAGCU	Level-1-260C-UNLIM	-40 to 85	OEN	Samples

(1) The marketing status values are defined as follows:

ACTIVE: Product device recommended for new designs.

LIFEBUY: TI has announced that the device will be discontinued, and a lifetime-buy period is in effect.

NRND: Not recommended for new designs. Device is in production to support existing customers, but TI does not recommend using this part in a new design.

PREVIEW: Device has been announced but is not in production. Samples may or may not be available.

OBSOLETE: TI has discontinued the production of the device.

(2) Eco Plan - The planned eco-friendly classification: Pb-Free (RoHS), Pb-Free (RoHS Exempt), or Green (RoHS & no Sb/Br) - please check <http://www.ti.com/productcontent> for the latest availability information and additional product content details.

TBD: The Pb-Free/Green conversion plan has not been defined.

Pb-Free (RoHS): TI's terms "Lead-Free" or "Pb-Free" mean semiconductor products that are compatible with the current RoHS requirements for all 6 substances, including the requirement that lead not exceed 0.1% by weight in homogeneous materials. Where designed to be soldered at high temperatures, TI Pb-Free products are suitable for use in specified lead-free processes.

Pb-Free (RoHS Exempt): This component has a RoHS exemption for either 1) lead-based flip-chip solder bumps used between the die and package, or 2) lead-based die adhesive used between the die and leadframe. The component is otherwise considered Pb-Free (RoHS compatible) as defined above.

Green (RoHS & no Sb/Br): TI defines "Green" to mean Pb-Free (RoHS compatible), and free of Bromine (Br) and Antimony (Sb) based flame retardants (Br or Sb do not exceed 0.1% by weight in homogeneous material)

(3) MSL, Peak Temp. -- The Moisture Sensitivity Level rating according to the JEDEC industry standard classifications, and peak solder temperature.

(4) Multiple Top-Side Markings will be inside parentheses. Only one Top-Side Marking contained in parentheses and separated by a "~" will appear on a device. If a line is indented then it is a continuation of the previous line and the two combined represent the entire Top-Side Marking for that device.

Important Information and Disclaimer: The information provided on this page represents TI's knowledge and belief as of the date that it is provided. TI bases its knowledge and belief on information provided by third parties, and makes no representation or warranty as to the accuracy of such information. Efforts are underway to better integrate information from third parties. TI has taken and continues to take reasonable steps to provide representative and accurate information but may not have conducted destructive testing or chemical analysis on incoming materials and chemicals. TI and TI suppliers consider certain information to be proprietary, and thus CAS numbers and other limited information may not be available for release.

In no event shall TI's liability arising out of such information exceed the total purchase price of the TI part(s) at issue in this document sold by TI to Customer on an annual basis.

TAPE AND REEL INFORMATION



QUADRANT ASSIGNMENTS FOR PIN 1 ORIENTATION IN TAPE



*All dimensions are nominal

Device	Package Type	Package Drawing	Pins	SPQ	Reel Diameter (mm)	Reel Width W1 (mm)	A0 (mm)	B0 (mm)	K0 (mm)	P1 (mm)	W (mm)	Pin1 Quadrant
TPA2015D1YZHR	DSBGA	YZH	16	3000	180.0	8.4	2.07	2.07	0.81	4.0	8.0	Q1

TAPE AND REEL BOX DIMENSIONS



*All dimensions are nominal

Device	Package Type	Package Drawing	Pins	SPQ	Length (mm)	Width (mm)	Height (mm)
TPA2015D1YZHR	DSBGA	YZH	16	3000	210.0	185.0	35.0

YZH (S-XBGA-N16)

DIE-SIZE BALL GRID ARRAY

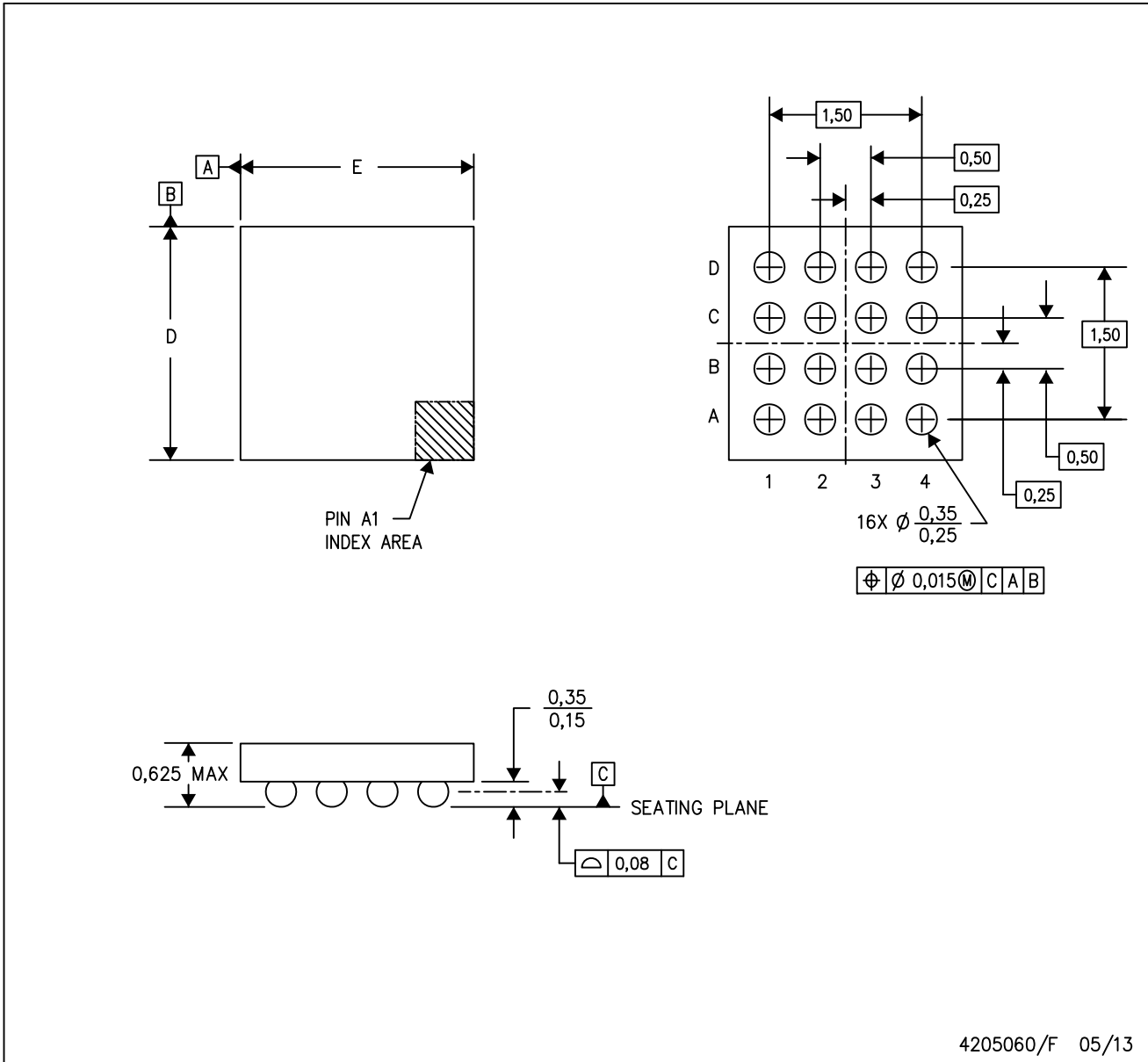

- NOTES:
- A. All linear dimensions are in millimeters.
 - B. This drawing is subject to change without notice.
 - C. NanoFree™ package configuration.

IMPORTANT NOTICE

Texas Instruments Incorporated and its subsidiaries (TI) reserve the right to make corrections, enhancements, improvements and other changes to its semiconductor products and services per JESD46, latest issue, and to discontinue any product or service per JESD48, latest issue. Buyers should obtain the latest relevant information before placing orders and should verify that such information is current and complete. All semiconductor products (also referred to herein as "components") are sold subject to TI's terms and conditions of sale supplied at the time of order acknowledgment.

TI warrants performance of its components to the specifications applicable at the time of sale, in accordance with the warranty in TI's terms and conditions of sale of semiconductor products. Testing and other quality control techniques are used to the extent TI deems necessary to support this warranty. Except where mandated by applicable law, testing of all parameters of each component is not necessarily performed.

TI assumes no liability for applications assistance or the design of Buyers' products. Buyers are responsible for their products and applications using TI components. To minimize the risks associated with Buyers' products and applications, Buyers should provide adequate design and operating safeguards.

TI does not warrant or represent that any license, either express or implied, is granted under any patent right, copyright, mask work right, or other intellectual property right relating to any combination, machine, or process in which TI components or services are used. Information published by TI regarding third-party products or services does not constitute a license to use such products or services or a warranty or endorsement thereof. Use of such information may require a license from a third party under the patents or other intellectual property of the third party, or a license from TI under the patents or other intellectual property of TI.

Reproduction of significant portions of TI information in TI data books or data sheets is permissible only if reproduction is without alteration and is accompanied by all associated warranties, conditions, limitations, and notices. TI is not responsible or liable for such altered documentation. Information of third parties may be subject to additional restrictions.

Resale of TI components or services with statements different from or beyond the parameters stated by TI for that component or service voids all express and any implied warranties for the associated TI component or service and is an unfair and deceptive business practice. TI is not responsible or liable for any such statements.

Buyer acknowledges and agrees that it is solely responsible for compliance with all legal, regulatory and safety-related requirements concerning its products, and any use of TI components in its applications, notwithstanding any applications-related information or support that may be provided by TI. Buyer represents and agrees that it has all the necessary expertise to create and implement safeguards which anticipate dangerous consequences of failures, monitor failures and their consequences, lessen the likelihood of failures that might cause harm and take appropriate remedial actions. Buyer will fully indemnify TI and its representatives against any damages arising out of the use of any TI components in safety-critical applications.

In some cases, TI components may be promoted specifically to facilitate safety-related applications. With such components, TI's goal is to help enable customers to design and create their own end-product solutions that meet applicable functional safety standards and requirements. Nonetheless, such components are subject to these terms.

No TI components are authorized for use in FDA Class III (or similar life-critical medical equipment) unless authorized officers of the parties have executed a special agreement specifically governing such use.

Only those TI components which TI has specifically designated as military grade or "enhanced plastic" are designed and intended for use in military/aerospace applications or environments. Buyer acknowledges and agrees that any military or aerospace use of TI components which have **not** been so designated is solely at the Buyer's risk, and that Buyer is solely responsible for compliance with all legal and regulatory requirements in connection with such use.

TI has specifically designated certain components as meeting ISO/TS16949 requirements, mainly for automotive use. In any case of use of non-designated products, TI will not be responsible for any failure to meet ISO/TS16949.

Products

Audio	www.ti.com/audio
Amplifiers	amplifier.ti.com
Data Converters	dataconverter.ti.com
DLP® Products	www.dlp.com
DSP	dsp.ti.com
Clocks and Timers	www.ti.com/clocks
Interface	interface.ti.com
Logic	logic.ti.com
Power Mgmt	power.ti.com
Microcontrollers	microcontroller.ti.com
RFID	www.ti-rfid.com
OMAP Applications Processors	www.ti.com/omap
Wireless Connectivity	www.ti.com/wirelessconnectivity

Applications

Automotive and Transportation	www.ti.com/automotive
Communications and Telecom	www.ti.com/communications
Computers and Peripherals	www.ti.com/computers
Consumer Electronics	www.ti.com/consumer-apps
Energy and Lighting	www.ti.com/energy
Industrial	www.ti.com/industrial
Medical	www.ti.com/medical
Security	www.ti.com/security
Space, Avionics and Defense	www.ti.com/space-avionics-defense
Video and Imaging	www.ti.com/video

TI E2E Community

e2e.ti.com