

Synchronous Buck NexFET™ Power Stage

FEATURES

- Over 92% System Efficiency at 15A
- Max Rated Continuous Current 25A, Peak 60A
- High Frequency Operation (up to 2 MHz)
- High Density - SON 3.5x4.5-mm Footprint
- Ultra Low Inductance Package
- System Optimized PCB Footprint
- Ultra Low Quiescent (ULQ) Current Mode
- 3.3V and 5V PWM Signal Compatible
- Diode Emulation Mode with FCCM
- Input Voltages up to 24V
- Three-State PWM Input
- Integrated Bootstrap Diode
- Shoot Through Protection
- RoHS Compliant – Lead Free Terminal Plating
- Halogen Free

APPLICATIONS

- Ultrabook/Notebook DC/DC Converters
- Multiphase Vcore and DDR Solutions
- Point-of-Load Synchronous Buck in Networking, Telecom, and Computing Systems

ORDERING INFORMATION

Device	Package	Media	Qty	Ship
CSD97374Q4M	SON 3.5 × 4.5-mm Plastic Package	13-Inch Reel	2500	Tape and Reel

DESCRIPTION

The CSD97374Q4M NexFET™ Power Stage is a highly optimized design for use in a high power, high density Synchronous Buck converter. This product integrates the driver IC and NexFET technology to complete the power stage switching function. The driver IC has a built-in selectable diode emulation function that enables DCM operation to improve light load efficiency. In addition, the driver IC supports ULQ mode that enables Connected Standby for Windows™ 8 . With the PWM input in tri-state, quiescent current is reduced to 130 μ A, with immediate response. When SKIP# is held at tri-state, the current is reduced to 8 μ A (typically 20 μ s is required to resume switching). This combination produces a high current, high efficiency, and high speed switching device in a small 3.5 × 4.5-mm outline package. In addition, the PCB footprint has been optimized to help reduce design time and simplify the completion of the overall system design.

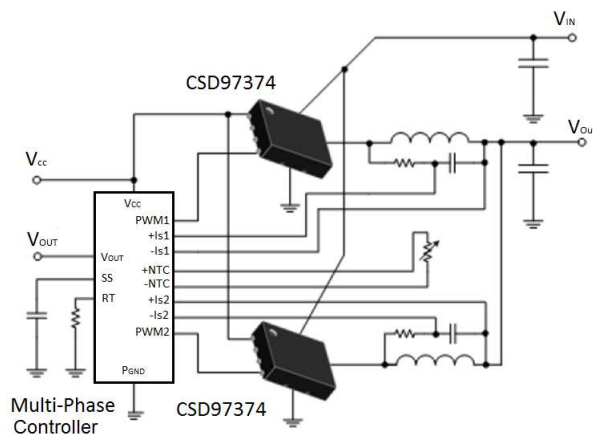

Figure 1. Application Diagram

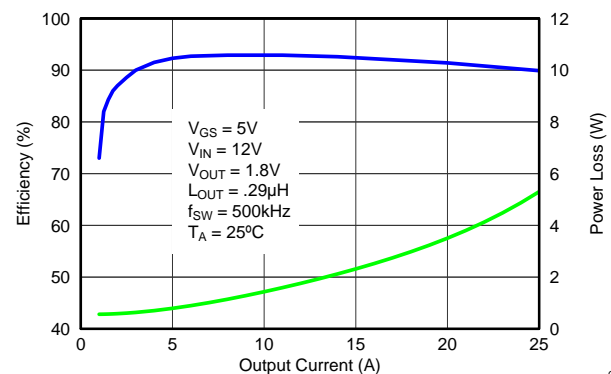

Figure 2. Efficiency and Power Loss



Please be aware that an important notice concerning availability, standard warranty, and use in critical applications of Texas Instruments semiconductor products and disclaimers thereto appears at the end of this data sheet.

NexFET is a trademark of Texas Instruments.

All other trademarks are the property of their respective owners.

CSD97374Q4M

SLPS382B – JANUARY 2013 – REVISED MAY 2013

www.ti.com



These devices have limited built-in ESD protection. The leads should be shorted together or the device placed in conductive foam during storage or handling to prevent electrostatic damage to the MOS gates.

ABSOLUTE MAXIMUM RATINGS⁽¹⁾

T_A = 25°C (unless otherwise noted)

	VALUE		UNIT	
	MIN	MAX		
V _{IN} to P _{GND}	-0.3	30	V	
V _{SW} to P _{GND} , V _{IN} to V _{SW}	-0.3	30	V	
V _{SW} to P _{GND} , V _{IN} to V _{SW} (<10ns)	-7	33	V	
V _{DD} to P _{GND}	-0.3	6	V	
PWM, SKIP# to P _{GND}	-0.3	6	V	
BOOT to P _{GND}	-0.3	35	V	
BOOT to P _{GND} (<10ns)	-2	38	V	
BOOT to BOOT_R	-0.3	6	V	
ESD Rating	Human Body Model (HBM)		2000	V
	Charged Device Model (CDM)		500	V
Power Dissipation, P _D		8	W	
Operating Temperature Range, T _J	-40	150	°C	
Storage Temperature Range, T _{STG}	-55	150	°C	

- (1) Stresses above those listed in "Absolute Maximum Ratings" may cause permanent damage to the device. These are stress ratings only and functional operation of the device at these or any other conditions beyond those indicated under "Recommended Operating Conditions" is not implied. Exposure to Absolute Maximum rated conditions for extended periods may affect device reliability.

RECOMMENDED OPERATING CONDITIONS

T_A = 25° (unless otherwise noted)

Parameter	Conditions	MIN	MAX	UNIT
Gate Drive Voltage, V _{DD}		4.5	5.5	V
Input Supply Voltage, V _{IN}			24	V
Continuous Output Current, I _{OUT}	V _{IN} = 12V, V _{DD} = 5V, V _{OUT} = 1.8V, f _{SW} = 500kHz, L _{OUT} = 0.29µH ⁽¹⁾		25	A
Peak Output Current, I _{OUT-PK} ⁽²⁾			60	A
Switching Frequency, f _{SW}	C _{BST} = 0.1µF (min)		2000	kHz
On Time Duty Cycle			85	%
Minimum PWM On Time		40		ns
Operating Temperature		-40	125	°C

- (1) Measurement made with six 10-µF (TDK C3216X5R1C106KT or equivalent) ceramic capacitors placed across V_{IN} to P_{GND} pins.
 (2) System conditions as defined in Note 1. Peak Output Current is applied for t_p = 10ms, duty cycle ≤ 1%

THERMAL INFORMATION

T_A = 25°C (unless otherwise noted)

PARAMETER		MIN	TYP	MAX	UNIT
R _{θJC}	Thermal Resistance, Junction-to-Case (Top of package) ⁽¹⁾			22.8	°C/W
R _{θJB}	Thermal Resistance, Junction-to-Board ⁽²⁾			2.5	°C/W

- (1) R_{θJC} is determined with the device mounted on a 1-inch² (6.45 -cm²), 2-oz (.071-mm thick) Cu pad on a 1.5-inch x 1.5-inch, 0.06-inch (1.52-mm) thick FR4 board.
 (2) R_{θJB} value based on hottest board temperature within 1mm of the package.

ELECTRICAL CHARACTERISTICS
 $T_A = 25^\circ\text{C}$, $V_{DD} = \text{POR to } 5.5\text{V}$ (unless otherwise noted)

PARAMETER	CONDITIONS	MIN	TYP	MAX	UNIT
P_{Loss}					
Power Loss ⁽¹⁾	$V_{IN} = 12\text{V}$, $V_{DD} = 5\text{V}$, $V_{OUT} = 1.8\text{V}$, $I_{OUT} = 15\text{A}$, $f_{SW} = 500\text{kHz}$, $L_{OUT} = 0.29\mu\text{H}$, $T_J = 25^\circ\text{C}$		2.3		W
Power Loss ⁽²⁾	$V_{IN} = 19\text{V}$, $V_{DD} = 5\text{V}$, $V_{OUT} = 1.8\text{V}$, $I_{OUT} = 15\text{A}$, $f_{SW} = 500\text{kHz}$, $L_{OUT} = 0.29\mu\text{H}$, $T_J = 25^\circ\text{C}$		2.5		W
Power Loss ⁽²⁾	$V_{IN} = 19\text{V}$, $V_{DD} = 5\text{V}$, $V_{OUT} = 1.8\text{V}$, $I_{OUT} = 15\text{A}$, $f_{SW} = 500\text{kHz}$, $L_{OUT} = 0.29\mu\text{H}$, $T_J = 125^\circ\text{C}$		2.8		W
V_{IN}					
V_{IN} Quiescent Current, I_Q	PWM=Floating, $V_{DD} = 5\text{V}$, $V_{IN} = 24\text{V}$			1	μA
V_{DD}					
Standby Supply Current, I_{DD}	PWM = Float, SKIP# = V_{DD} or 0V		130		μA
	SKIP# = Float		8		μA
Operating Supply Current, I_{DD}	PWM = 50% Duty cycle, $f_{SW} = 500\text{kHz}$		8.2		mA
POWER-ON RESET AND UNDER VOLTAGE LOCKOUT					
Power-On Reset, V_{DD} Rising				4.15	V
UVLO, V_{DD} Falling		3.7			V
Hysteresis			0.2		mV
PWM and SKIP# I/O Specifications					
Input Impedance, R_I	Pull Up to V_{DD}		1700		k Ω
	Pull Down (to GND)		800		
Logic Level High, V_{IH}		2.65			V
Logic Level Low, V_{IL}			0.6		
Hysteresis, V_{IH}			0.2		
Tri-State Voltage, V_{TS}		1.3		2	
Tri-state Activation Time (falling) PWM, $t_{THOLD(off1)}$			60		ns
Tri-state Activation Time (rising) PWM, $t_{THOLD(off2)}$			60		
Tri-state Activation Time (falling) SKIP#, t_{TSKF}			1		μs
Tri-state Activation Time (rising) SKIP#, t_{TSKR}			1		
Tri-state Exit Time PWM, $t_{3RD(PWM)}$ ⁽²⁾				100	ns
Tri-state Exit Time SKIP#, $t_{3RD(SKIP\#)}$ ⁽²⁾				50	μs
BOOTSTRAP SWITCH					
Forward Voltage, V_{FBST}	$I_F = 10\text{mA}$		120	240	mV
Reverse Leakage, I_{RLEAK} ⁽²⁾	$V_{BST} - V_{DD} = 25\text{V}$			2	μA

(1) Measurement made with six 10- μF (TDK C3216X5R1C106KT or equivalent) ceramic capacitors placed across V_{IN} to P_{GND} pins.

(2) Specified by design

TYPICAL CHARACTERISTICS

T_J = 125°C, unless stated otherwise.

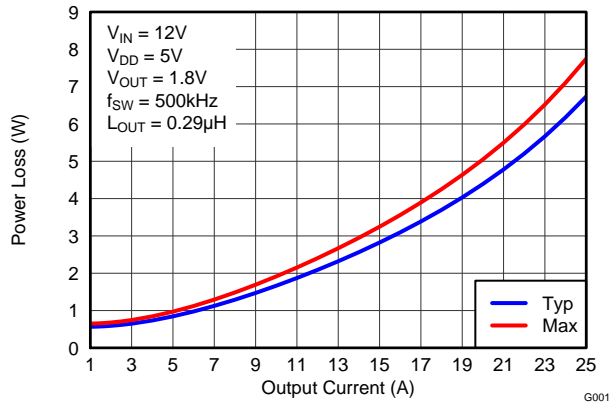

Figure 3. Power Loss vs Output Current

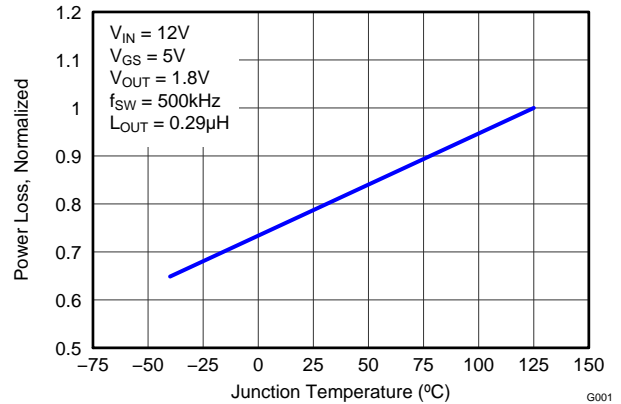

Figure 4. Power Loss vs Temperature

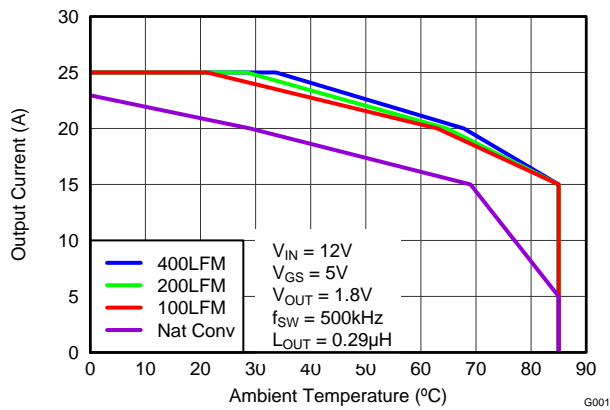

Figure 5. Safe Operating Area – PCB Horizontal Mount (1)

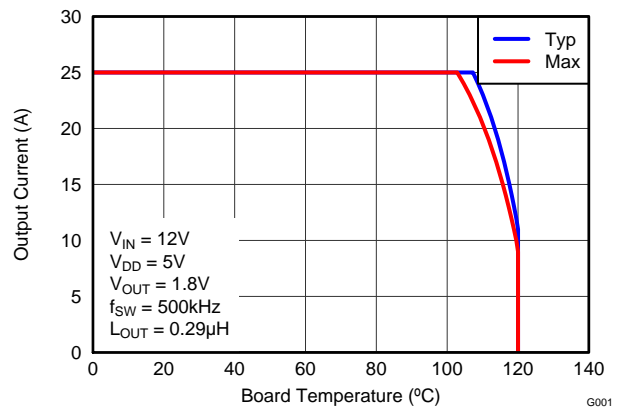

Figure 6. Typical Safe Operating Area (1)

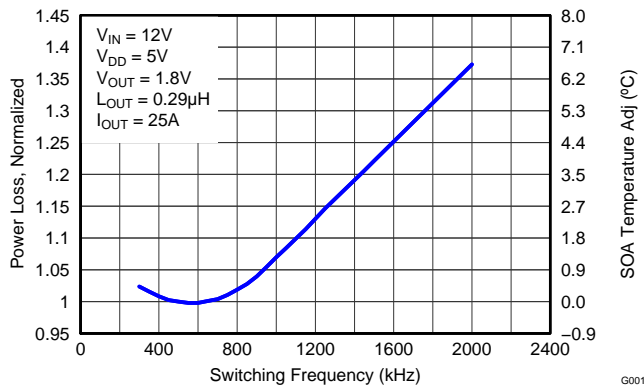

Figure 7. Normalized Power Loss vs Frequency

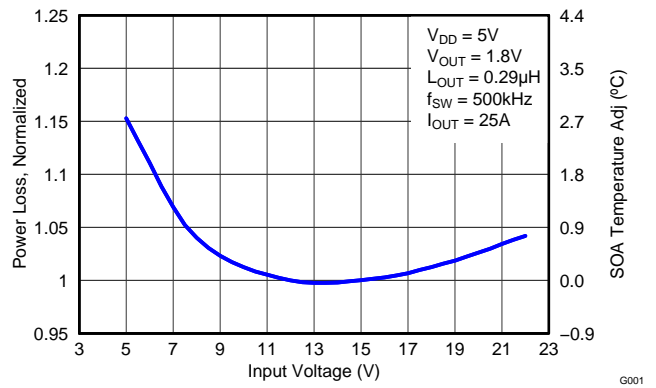

Figure 8. Normalized Power Loss vs Input Voltage

TYPICAL CHARACTERISTICS (continued)

T_J = 125°C, unless stated otherwise.

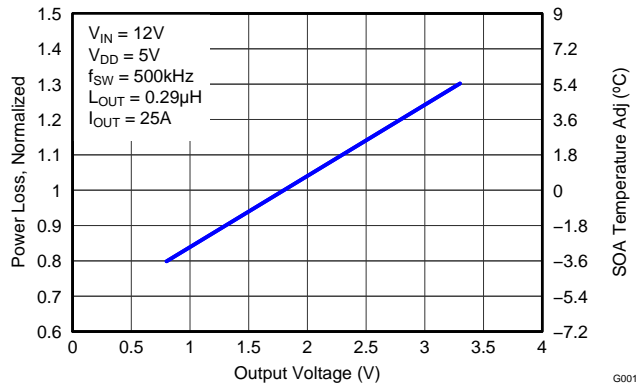

Figure 9. Normalized Power Loss vs Output Voltage

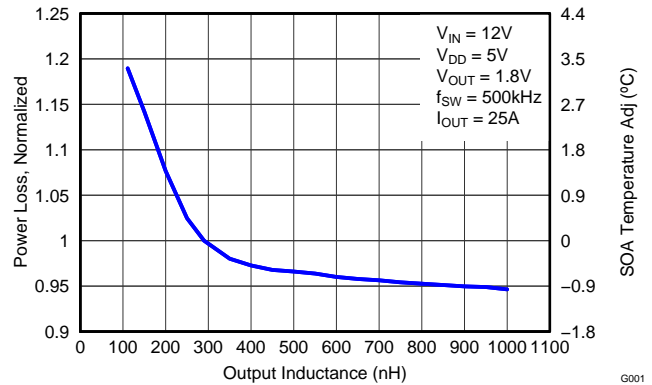

Figure 10. Normalized Power Loss vs Output Inductance

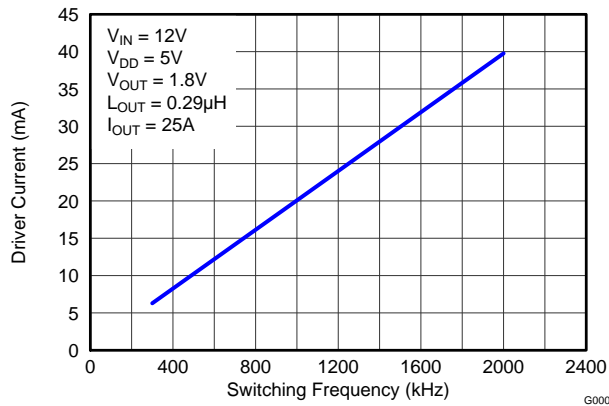

Figure 11. Driver Current vs Frequency

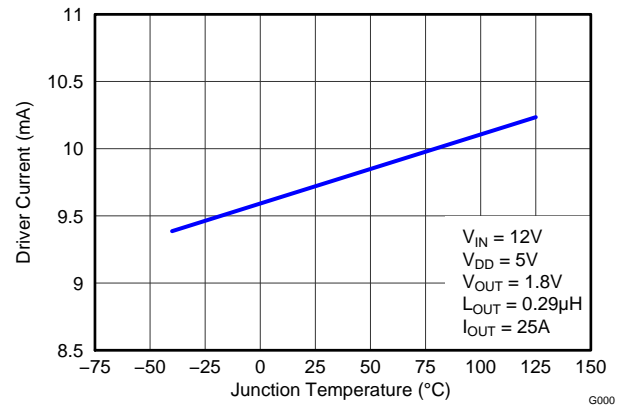

Figure 12. Driver Current vs Temperature

1. The Typical CSD97374Q4M System Characteristic curves are based on measurements made on a PCB design with dimensions of 4.0" (W) x 3.5" (L) x 0.062" (T) and 6 copper layers of 1 oz. copper thickness. See the [Application Information](#) section for detailed explanation.

PIN CONFIGURATION

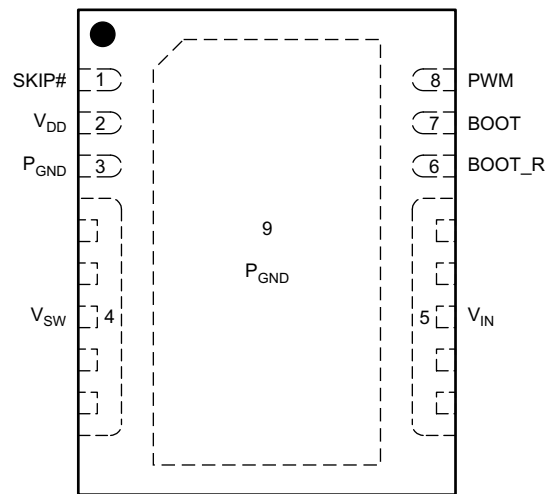

Figure 13. Top View

PIN DESCRIPTION

PIN		DESCRIPTION
NO.	NAME	
1	SKIP#	This pin enables the Diode Emulation function. When this pin is held Low, Diode Emulation Mode is enabled for the Sync FET. When SKIP# is High, the CSD97374Q4M operates in Forced Continuous Conduction Mode. A tri-state voltage on SKIP# puts the driver into a very low power state.
2	V _{DD}	Supply Voltage to Gate Drivers and internal circuitry.
3	P _{GND}	Power Ground, Needs to be connected to Pin 9 and PCB
4	V _{SW}	Voltage Switching Node – pin connection to the output inductor.
5	V _{IN}	Input Voltage Pin. Connect input capacitors close to this pin.
6	BOOT_R	Bootstrap capacitor connection. Connect a minimum 0.1µF 16V X5R, ceramic cap from BOOT to BOOT_R pins. The bootstrap capacitor provides the charge to turn on the Control FET. The bootstrap diode is integrated.
7	BOOT	
8	PWM	Pulse Width modulated 3-state input from external controller. Logic Low sets Control FET gate low and Sync FET gate high. Logic High sets Control FET gate high and Sync FET gate Low. Open or High Z sets both MOSFET gates low if greater than the 3-State Shutdown Hold-off Time (t _{3HT})
9	P _{GND}	Power Ground

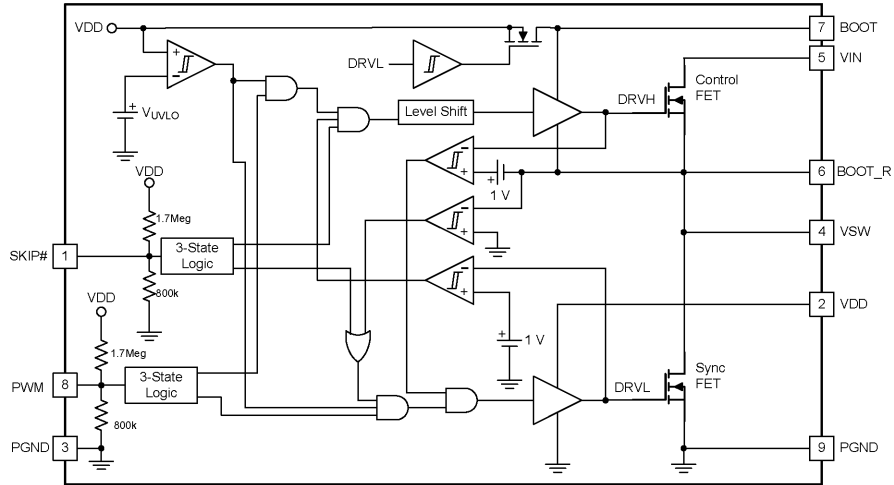

Figure 14. Functional Block Diagram

FUNCTIONAL DESCRIPTION

POWERING CSD97374Q4M AND GATE DRIVERS

An external V_{DD} voltage is required to supply the integrated gate driver IC and provide the necessary gate drive power for the MOSFETs. A $1\mu\text{F}$ 10V X5R or higher ceramic capacitor is recommended to bypass V_{DD} pin to P_{GND} . A bootstrap circuit to provide gate drive power for the Control FET is also included. The bootstrap supply to drive the Control FET is generated by connecting a 100nF 16V X5R ceramic capacitor between BOOT and BOOT_R pins. An optional R_{BOOT} resistor can be used to slow down the turn on speed of the Control FET and reduce voltage spikes on the V_{SW} node. A typical 1Ω to 4.7Ω value is a compromise between switching loss and V_{SW} spike amplitude.

Undervoltage Lockout Protection (UVLO)

The undervoltage lockout (UVLO) comparator evaluates the V_{DD} voltage level. As V_{DD} rises, both the Control FET and Sync FET gates hold actively low at all times until V_{DD} reaches the higher UVLO threshold (V_{UVLO_H}). Then the driver becomes operational and responds to PWM and SKIP# commands. If V_{DD} falls below the lower UVLO threshold ($V_{UVLO_L} = V_{UVLO_H} - \text{Hysteresis}$), the device disables the driver and drives the outputs of the Control FET and Sync FET gates actively low. Figure 15 shows this function.

CAUTION

Do not start the driver in the very low power mode (SKIP# = Tri-state).

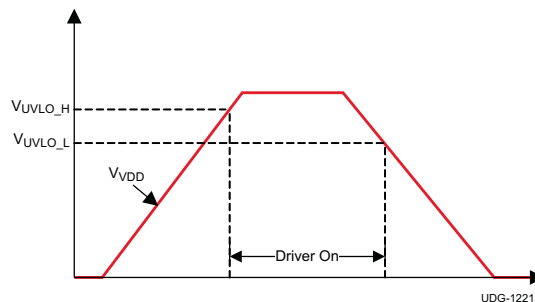

Figure 15. UVLO Operation

PWM Pin

The PWM pin incorporates an input tri-state function. The device forces the gate driver outputs to low when PWM is driven into the tri-state window and the driver enters a low power state with zero exit latency. The pin incorporates a weak pull-up to maintain the voltage within the tri-state window during low-power modes. Operation into and out of tri-state mode follows the timing diagram outlined in Figure 16.

When VDD reaches the UVLO_H level, a tri-state voltage range (window) is set for the PWM input voltage. The window is defined the PWM voltage range between PWM logic high (V_{IH}) and logic low (V_{IL}) thresholds. The device sets high-level input voltage and low-level input voltage threshold levels to accommodate both 3.3 V (typical) and 5 V (typical) PWM drive signals.

When the PWM exits tri-state, the driver enters CCM for a period of 4 μ s, regardless of the state of the SKIP# pin. Normal operation requires this time period in order for the auto-zero comparator to resume.

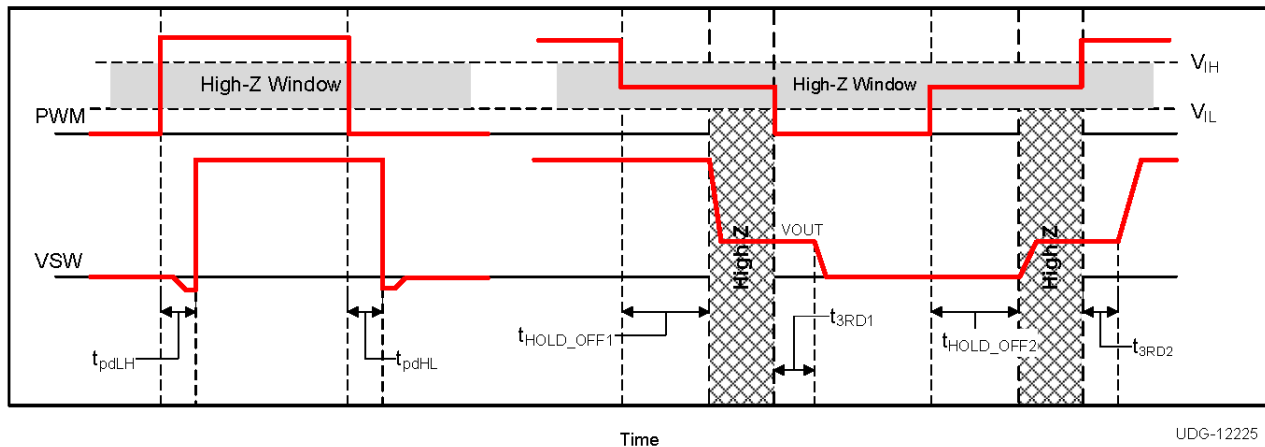

Figure 16. PWM Tri-State Timing Diagram

SKIP# Pin

The SKIP# pin incorporates the input tri-state buffer as PWM. The function is somewhat different. When SKIP# is low, the zero crossing (ZX) detection comparator is enabled, and DCM mode operation occurs if the load current is less than the critical current. When SKIP# is high, the ZX comparator disables, and the converter enters FCCM mode. When both SKIP# and PWM are tri-stated, normal operation forces the gate driver outputs low and the driver enters a low-power state. In the low-power state, the UVLO comparator remains off to reduce quiescent current. When SKIP# is pulled low, the driver wakes up and is able to accept PWM pulses in less than 50 μ s.

Table 1 shows the logic functions of UVLO, PWM, SKIP#, the Control FET Gate and the Sync FET Gate.

Table 1. Logic Functions of the Driver IC

UVLO	PWM	SKIP#	Sync FET Gate	Control FET Gate	MODE
Active	—	—	Low	Low	Disabled
Inactive	Low	Low	High ⁽¹⁾	Low	DCM ⁽¹⁾
Inactive	Low	High	High	Low	FCCM
Inactive	High	H or L	Low	High	
Inactive	Tri-state	H or L	Low	Low	LQ
Inactive	—	Tri-state	Low	Low	ULQ

(1) Until zero crossing protection occurs.

Zero Crossing (ZX) Operation

The zero crossing comparator is adaptive for improved accuracy. As the output current decreases from a heavy load condition, the inductor current also reduces and eventually arrives at a *valley*, where it touches zero current, which is the boundary between continuous conduction and discontinuous conduction modes. The SW pin detects the zero-current condition. When this zero inductor current condition occurs, the ZX comparator turns off the rectifying MOSFET.

Integrated Boost-Switch

To maintain a BST-SW voltage close to VDD (to get lower conduction losses on the high-side FET), the conventional diode between the VDD pin and the BST pin is replaced by a FET which is gated by the DRV1 signal.

APPLICATION INFORMATION

The Power Stage CSD97374Q4M is a highly optimized design for synchronous buck applications using NexFET devices with a 5V gate drive. The Control FET and Sync FET silicon are parametrically tuned to yield the lowest power loss and highest system efficiency. As a result, a rating method is used that is tailored towards a more systems centric environment. The high-performance gate driver IC integrated in the package helps minimize the parasitics and results in extremely fast switching of the power MOSFETs. System level performance curves such as Power Loss, Safe Operating Area and normalized graphs allow engineers to predict the product performance in the actual application.

Power Loss Curves

MOSFET centric parameters such as $R_{DS(ON)}$ and Q_{gd} are primarily needed by engineers to estimate the loss generated by the devices. In an effort to simplify the design process for engineers, Texas Instruments has provided measured power loss performance curves. Figure 3 plots the power loss of the CSD97374Q4M as a function of load current. This curve is measured by configuring and running the CSD97374Q4M as it would be in the final application (see Figure 17). The measured power loss is the CSD97374Q4M device power loss which consists of both input conversion loss and gate drive loss. Equation 1 is used to generate the power loss curve.

$$\text{Power Loss} = (V_{IN} \times I_{IN}) + (V_{DD} \times I_{DD}) - (V_{SW_AVG} \times I_{OUT}) \tag{1}$$

The power loss curve in Figure 3 is measured at the maximum recommended junction temperature of $T_J = 125^\circ\text{C}$ under isothermal test conditions.

Safe Operating Curves (SOA)

The SOA curves in the CSD97374Q4M datasheet give engineers guidance on the temperature boundaries within an operating system by incorporating the thermal resistance and system power loss. Figure 5 and Figure 6 outline the temperature and airflow conditions required for a given load current. The area under the curve dictates the safe operating area. All the curves are based on measurements made on a PCB design with dimensions of 4.0" (W) x 3.5" (L) x 0.062" (T) and 6 copper layers of 1 oz. copper thickness.

Normalized Curves

The normalized curves in the CSD97374Q4M data sheet give engineers guidance on the Power Loss and SOA adjustments based on their application specific needs. These curves show how the power loss and SOA boundaries will adjust for a given set of systems conditions. The primary Y-axis is the normalized change in power loss and the secondary Y-axis is the change in system temperature required in order to comply with the SOA curve. The change in power loss is a multiplier for the Power Loss curve and the change in temperature is subtracted from the SOA curve.

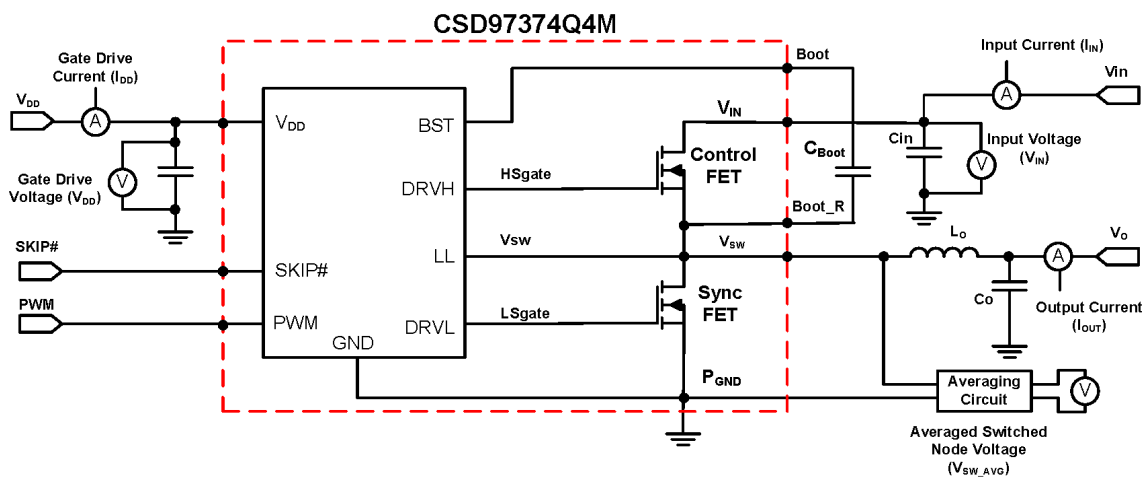

Figure 17. Power Loss Test Circuit

Calculating Power Loss and SOA

The user can estimate product loss and SOA boundaries by arithmetic means (see the Design Example). Though the Power Loss and SOA curves in this datasheet are taken for a specific set of test conditions, the following procedure will outline the steps engineers should take to predict product performance for any set of system conditions.

Design Example

Operating Conditions: Output Current (I_{OUT}) = 15A, Input Voltage (V_{IN}) = 7V, Output Voltage (V_{OUT}) = 1.5V, Switching Frequency (f_{SW}) = 800kHz, Output Inductor (L_{OUT}) = 0.2μH

Calculating Power Loss

- Typical Power Loss at 15A = 2.8W (Figure 3)
- Normalized Power Loss for switching frequency \approx 1.02 (Figure 7)
- Normalized Power Loss for input voltage \approx 1.07 (Figure 8)
- Normalized Power Loss for output voltage \approx 0.94 (Figure 9)
- Normalized Power Loss for output inductor \approx 1.08 (Figure 10)
- **Final calculated Power Loss = 2.8W \times 1.02 \times 1.07 \times 0.94 \times 1.08 \approx 3.1W**

Calculating SOA Adjustments

- SOA adjustment for switching frequency \approx 0.3°C (Figure 7)
- SOA adjustment for input voltage \approx 1.2°C (Figure 8)
- SOA adjustment for output voltage \approx -1.1°C (Figure 9)
- SOA adjustment for output inductor \approx 1.4°C (Figure 10)
- **Final calculated SOA adjustment = 0.3 + 1.2 + (-1.1) + 1.4 \approx 1.8°C**

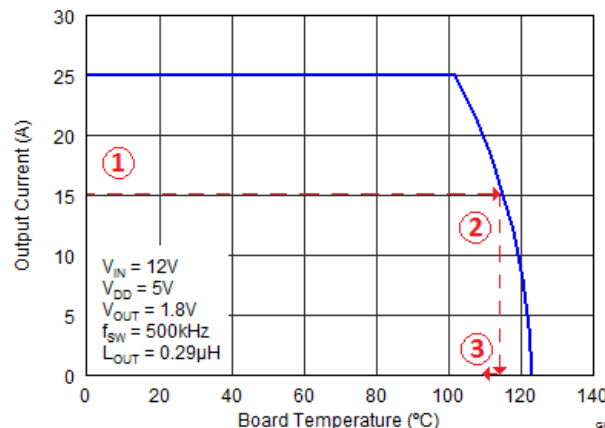

Figure 18. Power Stage CSD97374Q4M SOA

In the design example above, the estimated power loss of the CSD97374Q4M would increase to 3.1W. In addition, the maximum allowable board and/or ambient temperature would have to decrease by 1.8°C. Figure 18 graphically shows how the SOA curve would be adjusted accordingly.

1. Start by drawing a horizontal line from the application current to the SOA curve.
2. Draw a vertical line from the SOA curve intercept down to the board/ambient temperature.
3. Adjust the SOA board/ambient temperature by subtracting the temperature adjustment value.

In the design example, the SOA temperature adjustment yields a reduction in allowable board/ambient temperature of 1.8°C. In the event the adjustment value is a negative number, subtracting the negative number would yield an increase in allowable board/ambient temperature.

RECOMMENDED PCB DESIGN OVERVIEW

There are two key system-level parameters that can be addressed with a proper PCB design: electrical and thermal performance. Properly optimizing the PCB layout will yield maximum performance in both areas. Below is a brief description on how to address each parameter.

Electrical Performance

The CSD97374Q4M has the ability to switch at voltage rates greater than 10kV/μs. Special care must be then taken with the PCB layout design and placement of the input capacitors, inductor and output capacitors.

- The placement of the input capacitors relative to V_{IN} and P_{GND} pins of CSD97374Q4M device should have the highest priority during the component placement routine. It is critical to minimize these node lengths. As such, ceramic input capacitors need to be placed as close as possible to the V_{IN} and P_{GND} pins (see Figure 19). The example in Figure 19 uses 1 x 1nF 0402 25V and 3 x 10μF 1206 25V ceramic capacitors (TDK Part # C3216X5R1C106KT or equivalent). Notice there are ceramic capacitors on both sides of the board with an appropriate amount of vias interconnecting both layers. In terms of priority of placement next to the Power Stage C5, C8 and C6, C19 should follow in order.
- The bootstrap cap C_{BOOT} 0.1μF 0603 16V ceramic capacitor should be closely connected between BOOT and BOOT_R pins
- The switching node of the output inductor should be placed relatively close to the Power Stage CSD97374Q4M V_{SW} pins. Minimizing the V_{SW} node length between these two components will reduce the PCB conduction losses and actually reduce the switching noise level. ⁽²⁾

Thermal Performance

The CSD97374Q4M has the ability to use the GND planes as the primary thermal path. As such, the use of thermal vias is an effective way to pull away heat from the device and into the system board. Concerns of solder voids and manufacturability problems can be addressed by the use of three basic tactics to minimize the amount of solder attach that will wick down the via barrel:

- Intentionally space out the vias from each other to avoid a cluster of holes in a given area.
- Use the smallest drill size allowed in your design. The example in Figure 19 uses vias with a 10 mil drill hole and a 16 mil capture pad.
- Tent the opposite side of the via with solder-mask.

In the end, the number and drill size of the thermal vias should align with the end user's PCB design rules and manufacturing capabilities.

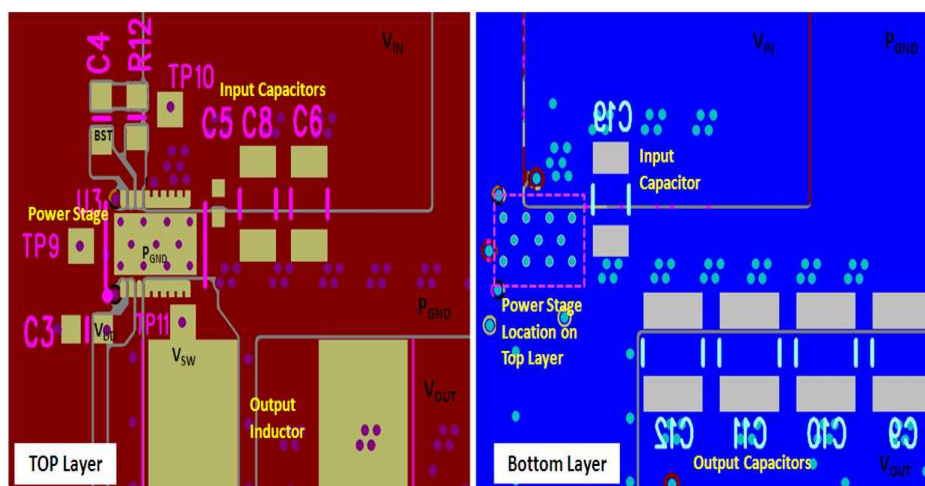
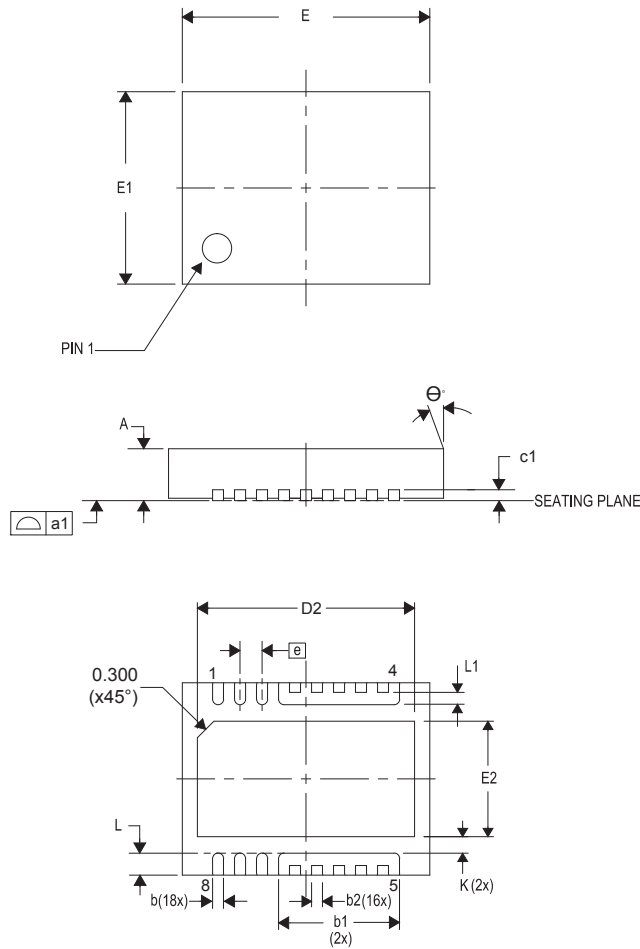

Figure 19. Recommended PCB Layout (Top Down View)

(2) Keong W. Kam, David Pommerenke, "EMI Analysis Methods for Synchronous Buck Converter EMI Root Cause Analysis", University of Missouri – Rolla

MECHANICAL DATA



DIM	MILLIMETERS			INCHES		
	Min	Nom	Max	Min	Nom	Max
A	0.800	0.900	1.000	0.031	0.035	0.039
a1	0.000	0.000	0.080	0.000	0.000	0.003
b	0.150	0.200	0.250	0.006	0.008	0.010
b1	2.000	2.200	2.400	0.079	0.087	0.095
c1	0.150	0.200	0.250	0.006	0.008	0.010
D2	3.850	3.950	4.050	0.152	0.156	0.160
E	4.400	4.500	4.600	0.173	0.177	0.181
E1	3.400	3.500	3.600	0.134	0.138	0.142
E2	2.000	2.100	2.200	0.079	0.083	0.087
e	0.400 TYP			0.016 TYP		
K	0.300 TYP			0.012 TYP		
L	0.300	0.400	0.500	0.012	0.016	0.020
L1	0.180	0.230	0.280	0.007	0.009	0.011
theta	0.00	—	—	0.00	—	—

CSD97374Q4M

SLPS382B - JANUARY 2013 - REVISED MAY 2013

www.ti.com

Recommended PCB Land Pattern

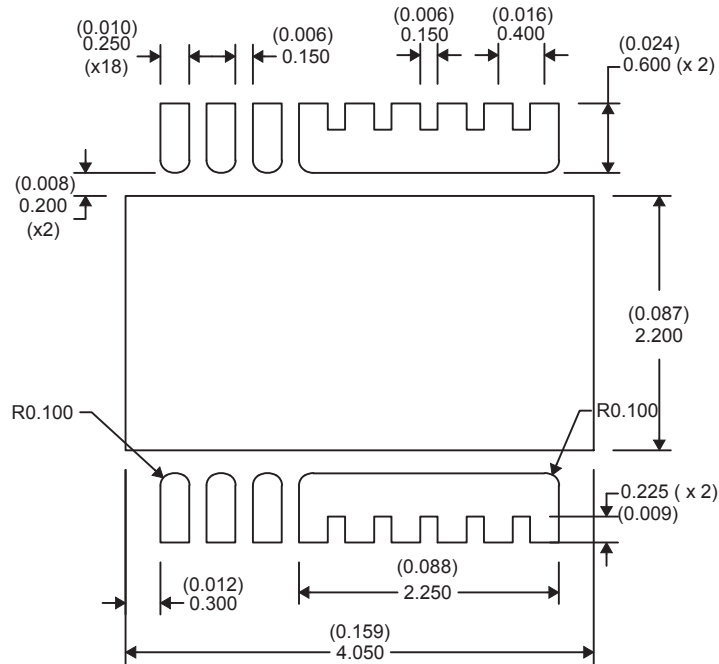

Recommended Stencil Opening

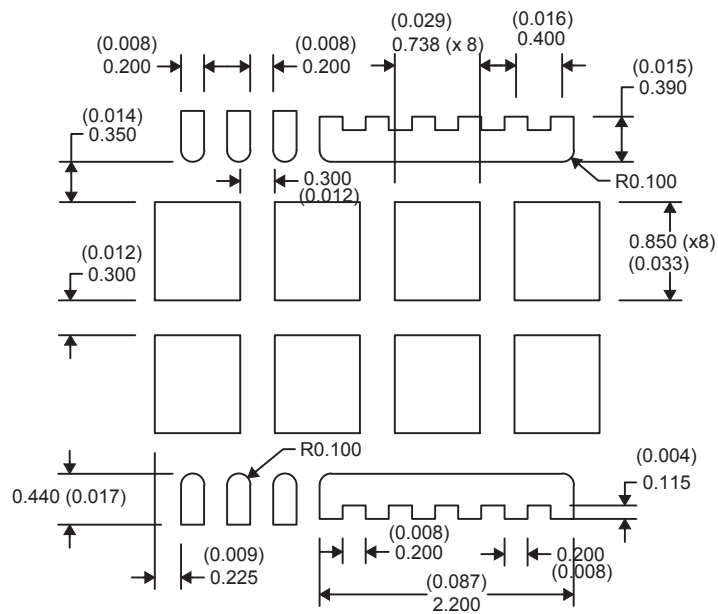

NOTE: Dimensions are in mm (inches).

REVISION HISTORY

Changes from Original (January 2013) to Revision A	Page
• Changed the ROC table, From: V_{SW} to P_{GND} , V_{IN} to V_{SW} (<20ns) MIN = -5 To: V_{SW} to P_{GND} , V_{IN} to V_{SW} (<10ns) MIN = -7	2
• Changed the ROC table, From: BOOT to P_{GND} (<20ns) MIN = -3 To: BOOT to P_{GND} (<10ns) MIN = -2	2
• Changed Logic Level High, V_{IH} From: MAX = 2.6 To: MIN = 2.65	3
• Changed Logic Level Low, V_{IL} From: MIN = 0.6 To: MAX = 0.6	3
• Changed Tri-State Voltage, V_{TS} From: MIN = 1.2 To: MIN = 1.3	3

Changes from Revision A (March 2013) to Revision B	Page
• Changed the Mechanical Drawing image	13
• Changed the Recommended PCB Land Pattern image	14
• Changed the Recommended Stencil Opening image	14

IMPORTANT NOTICE

Texas Instruments Incorporated and its subsidiaries (TI) reserve the right to make corrections, enhancements, improvements and other changes to its semiconductor products and services per JESD46, latest issue, and to discontinue any product or service per JESD48, latest issue. Buyers should obtain the latest relevant information before placing orders and should verify that such information is current and complete. All semiconductor products (also referred to herein as "components") are sold subject to TI's terms and conditions of sale supplied at the time of order acknowledgment.

TI warrants performance of its components to the specifications applicable at the time of sale, in accordance with the warranty in TI's terms and conditions of sale of semiconductor products. Testing and other quality control techniques are used to the extent TI deems necessary to support this warranty. Except where mandated by applicable law, testing of all parameters of each component is not necessarily performed.

TI assumes no liability for applications assistance or the design of Buyers' products. Buyers are responsible for their products and applications using TI components. To minimize the risks associated with Buyers' products and applications, Buyers should provide adequate design and operating safeguards.

TI does not warrant or represent that any license, either express or implied, is granted under any patent right, copyright, mask work right, or other intellectual property right relating to any combination, machine, or process in which TI components or services are used. Information published by TI regarding third-party products or services does not constitute a license to use such products or services or a warranty or endorsement thereof. Use of such information may require a license from a third party under the patents or other intellectual property of the third party, or a license from TI under the patents or other intellectual property of TI.

Reproduction of significant portions of TI information in TI data books or data sheets is permissible only if reproduction is without alteration and is accompanied by all associated warranties, conditions, limitations, and notices. TI is not responsible or liable for such altered documentation. Information of third parties may be subject to additional restrictions.

Resale of TI components or services with statements different from or beyond the parameters stated by TI for that component or service voids all express and any implied warranties for the associated TI component or service and is an unfair and deceptive business practice. TI is not responsible or liable for any such statements.

Buyer acknowledges and agrees that it is solely responsible for compliance with all legal, regulatory and safety-related requirements concerning its products, and any use of TI components in its applications, notwithstanding any applications-related information or support that may be provided by TI. Buyer represents and agrees that it has all the necessary expertise to create and implement safeguards which anticipate dangerous consequences of failures, monitor failures and their consequences, lessen the likelihood of failures that might cause harm and take appropriate remedial actions. Buyer will fully indemnify TI and its representatives against any damages arising out of the use of any TI components in safety-critical applications.

In some cases, TI components may be promoted specifically to facilitate safety-related applications. With such components, TI's goal is to help enable customers to design and create their own end-product solutions that meet applicable functional safety standards and requirements. Nonetheless, such components are subject to these terms.

No TI components are authorized for use in FDA Class III (or similar life-critical medical equipment) unless authorized officers of the parties have executed a special agreement specifically governing such use.

Only those TI components which TI has specifically designated as military grade or "enhanced plastic" are designed and intended for use in military/aerospace applications or environments. Buyer acknowledges and agrees that any military or aerospace use of TI components which have **not** been so designated is solely at the Buyer's risk, and that Buyer is solely responsible for compliance with all legal and regulatory requirements in connection with such use.

TI has specifically designated certain components as meeting ISO/TS16949 requirements, mainly for automotive use. In any case of use of non-designated products, TI will not be responsible for any failure to meet ISO/TS16949.

Products

Audio	www.ti.com/audio
Amplifiers	amplifier.ti.com
Data Converters	dataconverter.ti.com
DLP® Products	www.dlp.com
DSP	dsp.ti.com
Clocks and Timers	www.ti.com/clocks
Interface	interface.ti.com
Logic	logic.ti.com
Power Mgmt	power.ti.com
Microcontrollers	microcontroller.ti.com
RFID	www.ti-rfid.com
OMAP Applications Processors	www.ti.com/omap
Wireless Connectivity	www.ti.com/wirelessconnectivity

Applications

Automotive and Transportation	www.ti.com/automotive
Communications and Telecom	www.ti.com/communications
Computers and Peripherals	www.ti.com/computers
Consumer Electronics	www.ti.com/consumer-apps
Energy and Lighting	www.ti.com/energy
Industrial	www.ti.com/industrial
Medical	www.ti.com/medical
Security	www.ti.com/security
Space, Avionics and Defense	www.ti.com/space-avionics-defense
Video and Imaging	www.ti.com/video

TI E2E Community

e2e.ti.com