



## Real-Time Clock (RTC) With NVRAM Control

### Features

- Direct clock/calendar replacement for IBM® AT-compatible computers and other applications
- Functionally compatible with the DS1285
  - Closely matches MC146818A pin configuration
- 114 bytes of general nonvolatile storage
- Automatic backup and write-protect control to external SRAM
- 160 ns cycle time allows fast bus operation
  
- Less than 0.5 μA load under battery operation
- 14 bytes for clock/calendar and control

- Calendar in day of the week, day of the month, months, and years, with automatic leap-year adjustment
- Time of day in seconds, minutes, and hours
  - 12- or 24-hour format
  - Optional daylight saving adjustment
- BCD or binary format for clock and calendar data
- Programmable square wave output
- Three individually maskable interrupt event flags:
  - Periodic rates from 122 μs to 500 ms
  - Time-of-day alarm once per second to once per day
  - End-of-clock update cycle
- 24-pin plastic DIP or SOIC

### General Description

The CMOS bq4285 is a low-power microprocessor peripheral providing a time-of-day clock and 100-year calendar with alarm features and battery operation. Other features include three maskable interrupt sources, square wave output, and 114 bytes of general nonvolatile storage.

The bq4285 write-protects the clock, calendar, and storage registers during power failure. A backup battery then maintains data and operates the clock and calendar.

The bq4285 is a fully compatible real-time clock for IBM AT-compatible computers and other applications. The only external components are a 32.768kHz crystal and a backup battery.

The bq4285 integrates a battery-backup controller to make a standard CMOS SRAM nonvolatile during power-fail conditions. During power-fail, the bq4285 automatically write-protects the external SRAM and provides a V<sub>CC</sub> output sourced from the clock backup battery.

### Pin Connections

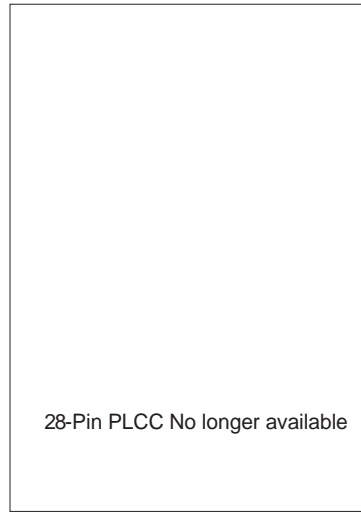
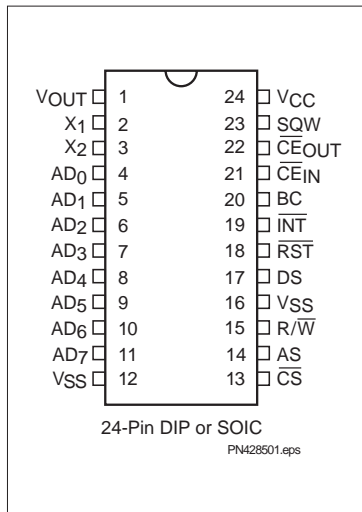

### Pin Names

AD <sub>0</sub> –AD <sub>7</sub>	Multiplexed address/data input/output
MOT	Bus type select input
$\overline{\text{CS}}$	Chip select input
AS	Address strobe input
DS	Data strobe input
R/W	Read/write input
$\overline{\text{INT}}$	Interrupt request output
RST	Reset input
SQW	Square wave output
BC	3V backup cell input
X1–X2	Crystal inputs
NC	No connect
$\overline{\text{CE}}_{\text{IN}}$	RAM chip enable input
$\overline{\text{CE}}_{\text{OUT}}$	RAM chip enable output
V <sub>OUT</sub>	Supply output
V <sub>CC</sub>	+5V supply
V <sub>SS</sub>	Ground

# bq4285

## Block Diagram

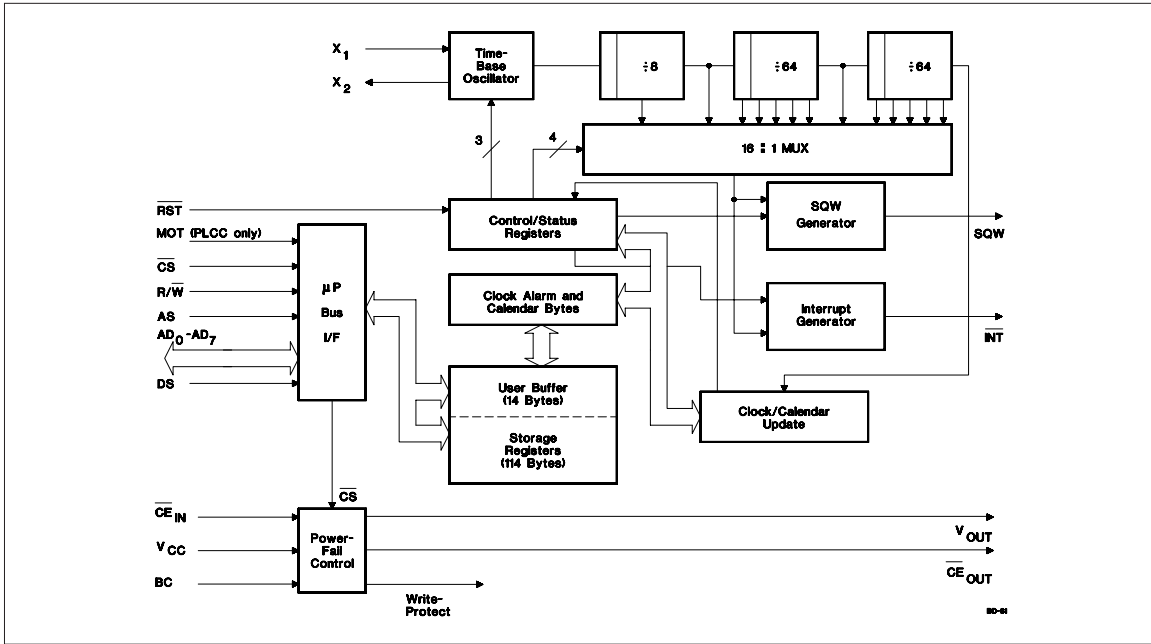

## Pin Descriptions

**AD<sub>0</sub>-AD<sub>7</sub>** Multiplexed address/data input/output

The bq4285 bus cycle consists of two phases: the address phase and the data-transfer phase. The address phase precedes the data-transfer phase. During the address phase, an address placed on AD<sub>0</sub>-AD<sub>7</sub> is latched into the bq4285 on the falling edge of the AS signal. During the data-transfer phase of the bus cycle, the AD<sub>0</sub>-AD<sub>7</sub> pins serve as a bidirectional data bus.

**MOT** Connect to VSS for correct operation

$\overline{\text{CS}}$

Chip select input

$\overline{\text{CS}}$  should be driven low and held stable during the data-transfer phase of a bus cycle accessing the bq4285.

Table 1. Bus Setup

Bus Type	MOT Level	DS Equivalent	R $\overline{\text{W}}$ Equivalent	AS Equivalent
			—	
Intel	V <sub>SS</sub>	$\overline{\text{RD}}$ , $\overline{\text{MEMR}}$ , or I/OR	$\overline{\text{WR}}$ , $\overline{\text{MEMW}}$ , or I/OW	ALE

<b>AS</b>	<b>Address strobe input</b>	AS serves to demultiplex the address/data bus. The falling edge of AS latches the address on AD <sub>0</sub> –AD <sub>7</sub> . This demultiplexing process is independent of the CS signal.	<b>SQW</b>	<b>Square-wave output</b>	Reset may be disabled by connecting $\overline{\text{RST}}$ to V <sub>CC</sub> . This allows the control bits to retain their states through power-down/power-up cycles.
<b>DS</b>	<b>Data strobe input</b>	With MOT = V <sub>SS</sub> , the DS input is provided a signal similar to RD, MEMR, or I/OR in an Intel-based system. The falling edge on DS is used to enable the outputs during a read cycle.	<b>BC</b>	<b>3V backup cell input</b>	BC should be connected to a 3V backup cell for RTC operation and storage register non-volatility in the absence of power. When V <sub>CC</sub> slews down past V <sub>BC</sub> (3V typical), the integral control circuitry switches the power source to BC. When V <sub>CC</sub> returns above V <sub>BC</sub> , the power source is switched to V <sub>CC</sub> .
<b>R/W</b>	<b>Read/write input</b>	With MOT = V <sub>SS</sub> , R/W is provided a signal similar to WR, MEMW, or I/OW in an Intel-based system. The rising edge on R/W latches data into the bq4285.	<b>X1-X2</b>	<b>Crystal inputs</b>	Upon power-up, a voltage within the V <sub>BC</sub> range must be present on the BC pin for the oscillator to start up.
<b>INT</b>	<b>Interrupt request output</b>	$\overline{\text{INT}}$ is an open-drain output. $\overline{\text{INT}}$ is asserted low when any event flag is set and the corresponding event enable bit is also set. $\overline{\text{INT}}$ becomes high-impedance whenever register C is read (see the Control/Status Registers section).	<b>CE<sub>IN</sub></b>	<b>External RAM chip enable input, active low</b>	The X1–X2 inputs are provided for an external 32.768Khz quartz crystal, Daiwa DT-26 or equivalent, with 6pF load capacitance. A trimming capacitor may be necessary for extremely precise time-base generation.
<b>RST</b>	<b>Reset input</b>	The bq4285 is reset when $\overline{\text{RST}}$ is pulled low. When reset, INT becomes high-impedance, and the bq4285 is not accessible. Table 4 in the Control/Status Registers section lists the register bits that are cleared by a reset.	<b>CE<sub>OUT</sub></b>	<b>External RAM chip enable output, active low</b>	$\overline{\text{CE}}_{\text{IN}}$ should be driven low to enable the controlled external RAM. $\overline{\text{CE}}_{\text{IN}}$ is internally pulled up with a 50KΩ resistor.
			<b>V<sub>OUT</sub></b>	<b>Supply output</b>	When power is valid, $\overline{\text{CE}}_{\text{OUT}}$ reflects $\overline{\text{CE}}_{\text{IN}}$ .
			<b>V<sub>CC</sub></b>	<b>+5V supply</b>	V <sub>OUT</sub> provides the higher of V <sub>CC</sub> or V <sub>BC</sub> , switched internally, to supply external RAM.
			<b>V<sub>SS</sub></b>	<b>Ground</b>	

# bq4285

## Functional Description

### Address Map

The bq4285 provides 14 bytes of clock and control/status registers and 114 bytes of general nonvolatile storage. Figure 1 illustrates the address map for the bq4285.

### Update Period

The update period for the bq4285 is one second. The bq4285 updates the contents of the clock and calendar locations during the update cycle at the end of each up-

date period (see Figure 2). The alarm flag bit may also be set during the update cycle.

The bq4285 copies the local register updates into the user buffer accessed by the host processor. When a 1 is written to the update transfer inhibit bit (UTI) in register B, the user copy of the clock and calendar bytes remains unchanged, while the local copy of the same bytes continues to be updated every second.

The update-in-progress bit (UIP) in register A is set  $t_{BUC}$  time before the beginning of an update cycle (see Figure 2). This bit is cleared and the update-complete flag (UF) is set at the end of the update cycle.

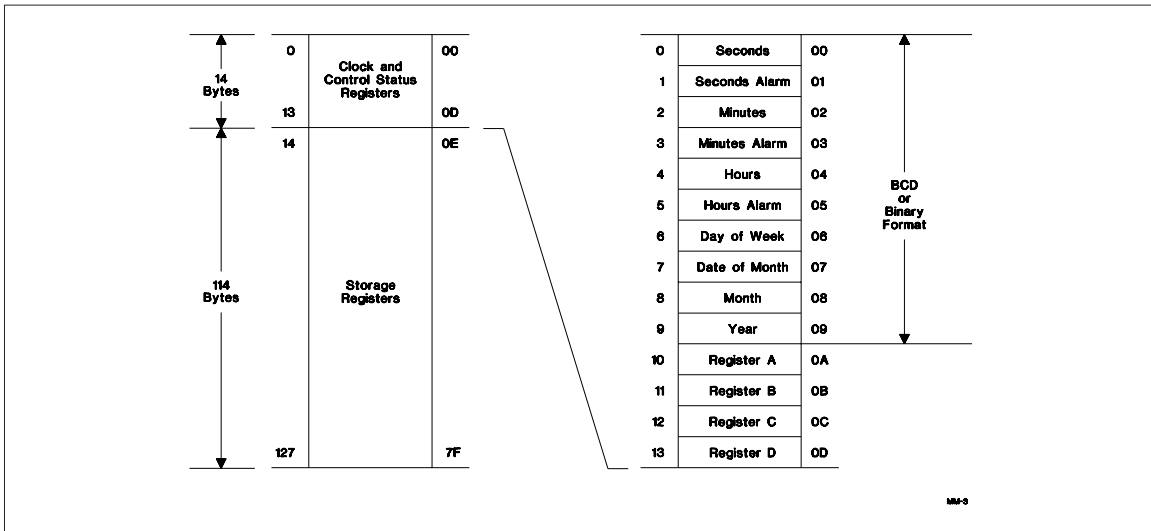

Figure 1. Address Map

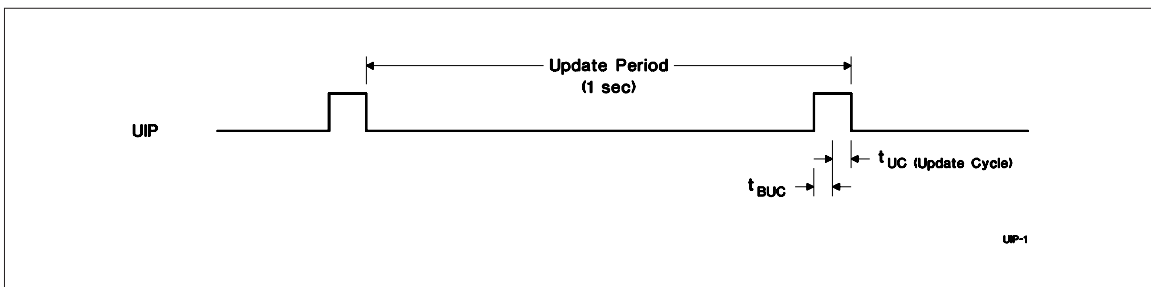

Figure 2. Update Period Timing and UIP

## Programming the RTC

The time-of-day, alarm, and calendar bytes can be written in either the BCD or binary format (see Table 2).

These steps may be followed to program the time, alarm, and calendar:

1. Modify the contents of register B:
  - a. Write a 1 to the UTI bit to prevent transfers between RTC bytes and user buffer.
  - b. Write the appropriate value to the data format (DF) bit to select BCD or binary format for all time, alarm, and calendar bytes.
- c. Write the appropriate value to the hour format (HF) bit.
2. Write new values to all the time, alarm, and calendar locations.
3. Clear the UTI bit to allow update transfers.

On the next update cycle, the RTC updates all 10 bytes in the selected format.

**Table 2. Time, Alarm, and Calendar Formats**

Address	RTC Bytes	Range		
		Decimal	Binary	Binary-Coded Decimal
0	Seconds	0–59	00H–3BH	00H–59H
1	Seconds alarm	0–59	00H–3BH	00H–59H
2	Minutes	0–59	00H–3BH	00H–59H
3	Minutes alarm	0–59	00H–3BH	00H–59H
4	Hours, 12-hour format	1–12	01H–0CH AM; 81H–8CH PM	01H–12H AM; 81H–92H PM
	Hours, 24-hour format	0–23	00H–17H	00H–23H
5	Hours alarm, 12-hour format	1–12	01H–0CH AM; 81H–8CH PM	01H–12H AM; 81H–92H PM
	Hours alarm, 24-hour format	0–23	00H–17H	00H–23H
6	Day of week (1=Sunday)	1–7	01H–07H	01H–07H
7	Day of month	1–31	01H–1FH	01H–31H
8	Month	1–12	01H–0CH	01H–12H
9	Year	0–99	00H–63H	00H–99H

# bq4285

## Square-Wave Output

The bq4285 divides the 32.768kHz oscillator frequency to produce the 1 Hz update frequency for the clock and calendar. Thirteen taps from the frequency divider are fed to a 16:1 multiplexer circuit. The output of this mux is fed to the SQW output and periodic interrupt generation circuitry. The four least-significant bits of register A, RS0–RS3, select among the 13 taps (see Table 3). The square-wave output is enabled by writing a 1 to the square-wave enable bit (SQWE) in register B.

## Interrupts

The bq4285 allows three individually selected interrupt events to generate an interrupt request. These three interrupt events are:

- The periodic interrupt, programmable to occur once every 122 μs to 500 ms
- The alarm interrupt, programmable to occur once per second to once per day

- The update-ended interrupt, which occurs at the end of each update cycle

Each of the three interrupt events is enabled by an individual interrupt-enable bit in register B. When an event occurs, its event flag bit in register C is set. If the corresponding event enable bit is also set, then an interrupt request is generated. The interrupt request flag bit (INTF) of register C is set with every interrupt request. Reading register C clears all flag bits, including INTF, and makes INT high-impedance.

Two methods can be used to process bq4285 interrupt events:

- Enable interrupt events and use the interrupt request output to invoke an interrupt service routine.
- Do not enable the interrupts and use a polling routine to periodically check the status of the flag bits.

The individual interrupt sources are described in detail in the following sections.

**Table 3. Square-Wave Frequency/Periodic Interrupt Rate**

Register A Bits				Square Wave		Periodic Interrupt	
RS3	RS2	RS1	RS0	Frequency	Units	Period	Units
0	0	0	0	None		None	
0	0	0	1	256	Hz	3.90625	ms
0	0	1	0	128	Hz	7.8125	ms
0	0	1	1	8.192	kHz	122.070	μs
0	1	0	0	4.096	kHz	244.141	μs
0	1	0	1	2.048	kHz	488.281	μs
0	1	1	0	1.024	kHz	976.5625	μs
0	1	1	1	512	Hz	1.95315	ms
1	0	0	0	256	Hz	3.90625	ms
1	0	0	1	128	Hz	7.8125	ms
1	0	1	0	64	Hz	15.625	ms
1	0	1	1	32	Hz	31.25	ms
1	1	0	0	16	Hz	62.5	ms
1	1	0	1	8	Hz	125	ms
1	1	1	0	4	Hz	250	ms
1	1	1	1	2	Hz	500	ms

### Periodic Interrupt

The mux output used to drive the SQW output also drives the interrupt-generation circuitry. If the periodic interrupt event is enabled by writing a 1 to the periodic interrupt enable bit (PIE) in register C, an interrupt request is generated once every 122 $\mu$ s to 500ms. The period between interrupts is selected by the same bits in register A that select the square wave frequency (see Table 3).

### Alarm Interrupt

During each update cycle, the RTC compares the hours, minutes, and seconds bytes with the three corresponding alarm bytes. If a match of all bytes is found, the alarm interrupt event flag bit, AF in register C, is set to 1. If the alarm event is enabled, an interrupt request is generated.

An alarm byte may be removed from the comparison by setting it to a “don’t care” state. An alarm byte is set to a “don’t care” state by writing a 1 to each of its two most-significant bits. A “don’t care” state may be used to select the frequency of alarm interrupt events as follows:

- If none of the three alarm bytes is “don’t care,” the frequency is once per day, when hours, minutes, and seconds match.
- If only the hour alarm byte is “don’t care,” the frequency is once per hour, when minutes and seconds match.
- If only the hour and minute alarm bytes are “don’t care,” the frequency is once per minute, when seconds match.
- If the hour, minute, and second alarm bytes are “don’t care,” the frequency is once per second.

### Update Cycle Interrupt

The update cycle ended flag bit (UF) in register C is set to a 1 at the end of an update cycle. If the update interrupt enable bit (UIE) of register B is 1, and the update transfer inhibit bit (UTI) in register B is 0, then an interrupt request is generated at the end of each update cycle.

### Accessing RTC bytes

Time and calendar bytes read during an update cycle may be in error. Three methods to access the time and calendar bytes without ambiguity are:

- Enable the update interrupt event to generate interrupt requests at the end of the update cycle. The interrupt handler has a maximum of 999ms to access the clock bytes before the next update cycle begins (see Figure 3).
- Poll the update-in-progress bit (UIP) in register A. If UIP = 0, the polling routine has a minimum of  $t_{BUC}$  time to access the clock bytes (see Figure 3).
- Use the periodic interrupt event to generate interrupt requests every  $t_{PI}$  time, such that  $UIP = 1$  always occurs between the periodic interrupts. The interrupt handler will have a minimum of  $t_{PI}/2 + t_{BUC}$  time to access the clock bytes (see Figure 3).

### Oscillator Control

When power is first applied to the bq4285 and  $V_{CC}$  is above  $V_{PFD}$ , the internal oscillator and frequency divider are turned on by writing a 010 pattern to bits 4 through 6 of register A. A pattern of 11X turns the oscillator on but keeps the frequency divider disabled. Any other pattern to these bits keeps the oscillator off.

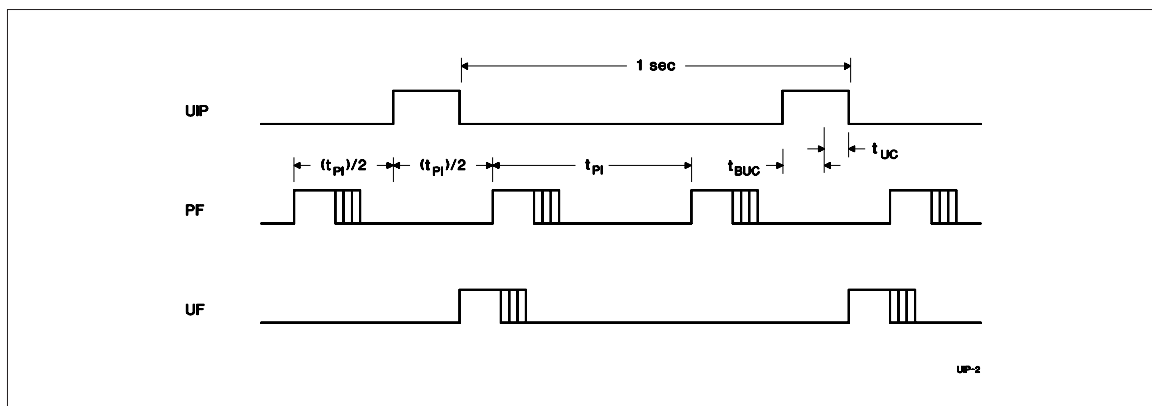

Figure 3. Update-Ended/Periodic Interrupt Relationship

# bq4285

## Power-Down/Power-Up Cycle

The bq4285 continuously monitors  $V_{CC}$  for out-of-tolerance. During a power failure, when  $V_{CC}$  falls below  $V_{PFD}$  (4.17V typical), the bq4285 write-protects the clock and storage registers. When  $V_{CC}$  is below  $V_{BC}$  (3V typical), the power source is switched to BC. RTC operation and storage data are sustained by a valid backup energy source. When  $V_{CC}$  is above  $V_{BC}$ , the power source is  $V_{CC}$ . Write-protection continues for  $t_{CSR}$  time after  $V_{CC}$  rises above  $V_{PFD}$ .

An external CMOS static RAM is battery-backed using the  $V_{OUT}$  and chip enable output pins from the bq4285. As the voltage input  $V_{CC}$  slows down during a power failure, the chip enable output,  $\overline{CE}_{OUT}$  is forced inactive independent of the chip enable input  $\overline{CE}_{IN}$ .

This activity unconditionally write-protects the external SRAM as  $V_{CC}$  falls below  $V_{PFD}$ . If a memory access is in process to the external SRAM during power-fail detection, that memory cycle continues to completion before the memory is write-protected. If the memory cycle is not terminated within time  $t_{WPT}$  (30 $\mu$ s maximum), the chip enable output is unconditionally driven high, write-protecting the controlled SRAM.

As the supply continues to fall past  $V_{PFD}$ , an internal switching device forces  $V_{OUT}$  to the external backup energy source.  $\overline{CE}_{OUT}$  is held high by the  $V_{OUT}$  energy source.

During power-up,  $V_{OUT}$  is switched back to the 5V supply as  $V_{CC}$  rises above the backup cell input voltage sourcing  $V_{OUT}$ .  $\overline{CE}_{OUT}$  is held inactive for time  $t_{CER}$  (200ms maximum) after the power supply has reached  $V_{PFD}$ , independent of the  $\overline{CE}_{IN}$  input, to allow for processor stabilization.

During power-valid operation, the  $\overline{CE}_{IN}$  input is passed through to the  $\overline{CE}_{OUT}$  output with a propagation delay of less than 10ns.

Figure 4 shows the hardware hookup for the external RAM.

A primary backup energy source input is provided on the bq4285. The BC input accepts a 3V primary battery, typically some type of lithium chemistry. To prevent battery drain when there is no valid data to retain,  $V_{OUT}$  and  $\overline{CE}_{OUT}$  are internally isolated from BC by the initial connection of a battery. Following the first application of  $V_{CC}$  above  $V_{PFD}$ , this isolation is broken, and the backup cell provides power to  $V_{OUT}$  and  $\overline{CE}_{OUT}$  for the external SRAM.

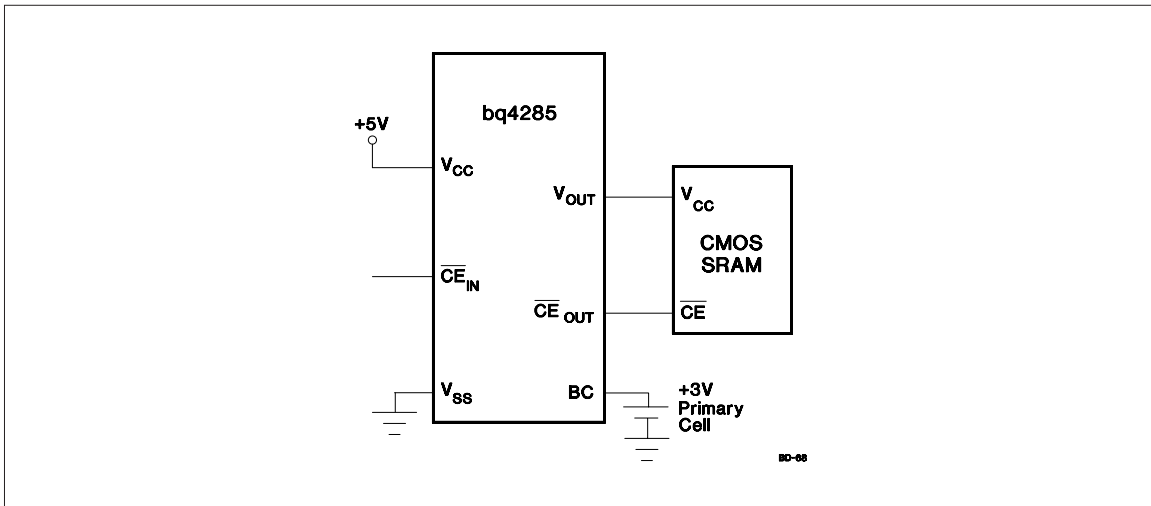

Figure 4. External RAM Hookup to the bq4285 RTC



## Control/Status Registers

The four control/status registers of the bq4285 are accessible regardless of the status of the update cycle (see Table 4).

### Register A

Register A Bits							
7	6	5	4	3	2	1	0
UIP	OS2	OS1	OS0	RS3	RS2	RS1	RS0

Register A programs:

- The frequency of the square-wave and the periodic event rate.
- Oscillator operation.

Register A provides:

- Status of the update cycle.

#### RS0–RS3 - Frequency Select

7	6	5	4	3	2	1	0
-	-	-	-	RS3	RS2	RS1	RS0

These bits select one of the 13 frequencies for the SQW output and the periodic interrupt rate, as shown in Table 3.

#### OS0–OS2 - Oscillator Control

7	6	5	4	3	2	1	0
-	OS2	OS1	OS0	-	-	-	-

These three bits control the state of the oscillator and divider stages. A pattern of 010 enables RTC operation by turning on the oscillator and enabling the frequency divider. A pattern of 11X turns the oscillator on, but keeps

the frequency divider disabled. When 010 is written, the RTC begins its first update after 500ms.

#### UIP - Update Cycle Status

7	6	5	4	3	2	1	0
UIP	-	-	-	-	-	-	-

This read-only bit is set prior to the update cycle. When UIP equals 1, an RTC update cycle may be in progress. UIP is cleared at the end of each update cycle. This bit is also cleared when the update transfer inhibit (UTI) bit in register B is 1.

### Register B

Register B Bits							
7	6	5	4	3	2	1	0
UTI	PIE	AIE	UIE	SQWE	DF	HF	DSE

Register B enables:

- Update cycle transfer operation
- Square-wave output
- Interrupt events
- Daylight saving adjustment

Register B selects:

- Clock and calendar data formats

All bits of register B are read/write.

Table 4. Control/Status Registers

Reg.	Loc. (Hex)	Read	Write	Bit Name and State on Reset															
				7 (MSB)		6		5		4		3		2		1		0 (LSB)	
A	0A	Yes	Yes <sup>1</sup>	UIP	na	OS2	na	OS1	na	OS0	na	RS3	na	RS2	na	RS1	na	RS0	na
B	0B	Yes	Yes	UTI	na	PIE	0	AIE	0	UIE	0	SQWE	0	DF	na	HF	na	DSE	na
C	0C	Yes	No	INTF	0	PF	0	AF	0	UF	0	-	0	-	0	-	0	-	0
D	0D	Yes	No	VRT	na	-	0	-	0	-	0	-	0	-	0	-	0	-	0

Notes: na = not affected.  
1. Except bit 7.

# bq4285

---

## DSE - Daylight Saving Enable

7	6	5	4	3	2	1	0
-	-	-	-	-	-	-	DSE

This bit enables daylight-saving time adjustments when written to 1:

- On the last Sunday in October, the first time the bq4285 increments past 1:59:59 AM, the time falls back to 1:00:00 AM.
- On the first Sunday in April, the time springs forward from 2:00:00 AM to 3:00:00 AM.

## HF - Hour Format

7	6	5	4	3	2	1	0
-	-	-	-	-	-	HF	-

This bit selects the time-of-day and alarm hour format:

- 1 = 24-hour format
- 0 = 12-hour format

## DF - Data Format

7	6	5	4	3	2	1	0
-	-	-	-	-	DF	-	-

This bit selects the numeric format in which the time, alarm, and calendar bytes are represented:

- 1 = Binary
- 0 = BCD

## SQWE - Square-Wave Enable

7	6	5	4	3	2	1	0
-	-	-	-	SQWE	-	-	-

This bit enables the square-wave output:

- 1 = Enabled
- 0 = Disabled and held low

## UIE - Update Cycle Interrupt Enable

7	6	5	4	3	2	1	0
-	-	-	UIE	-	-	-	-

This bit enables an interrupt request due to an update ended interrupt event:

- 1 = Enabled
- 0 = Disabled

The UIE bit is automatically cleared when the UTI bit equals 1.

## AIE - Alarm Interrupt Enable

7	6	5	4	3	2	1	0
-	-	AIE	-	-	-	-	-

This bit enables an interrupt request due to an alarm interrupt event:

- 1 = Enabled
- 0 = Disabled

## PIE - Periodic Interrupt Enable

7	6	5	4	3	2	1	0
-	PIE	-	-	-	-	-	-

This bit enables an interrupt request due to a periodic interrupt event:

- 1 = Enabled
- 0 = Disabled

## UTI - Update Transfer Inhibit

7	6	5	4	3	2	1	0
UTI	-	-	-	-	-	-	-

This bit inhibits the transfer of RTC bytes to the user buffer:

- 1 = Inhibits transfer and clears UIE
- 0 = Allows transfer

**Register C**

Register C Bits							
7	6	5	4	3	2	1	0
INTF	PF	AF	UF	0	0	0	0

Register C is the read-only event status register.

**Bits 0–3 - Unused Bits**

7	6	5	4	3	2	1	0
-	-	-	-	0	0	0	0

These bits are always set to 0.

**UF - Update-Event Flag**

7	6	5	4	3	2	1	0
-	-	-	UF	-	-	-	-

This bit is set to a 1 at the end of the update cycle. Reading register C clears this bit.

**AF - Alarm Event Flag**

7	6	5	4	3	2	1	0
-	-	AF	-	-	-	-	-

This bit is set to a 1 when an alarm event occurs. Reading register C clears this bit.

7	6	5	4	3	2	1	0
-	PF	-	-	-	-	-	-

**PF - Periodic Event Flag**

This bit is set to a 1 every  $t_{PI}$  time, where  $t_{PI}$  is the time period selected by the settings of RS0–RS3 in register A. Reading register C clears this bit.

**INTF - Interrupt Request Flag**

7	6	5	4	3	2	1	0
INTF	-	-	-	-	-	-	-

This flag is set to a 1 when any of the following is true:

AIE = 1 and AF = 1

PIE = 1 and PF = 1

UIE = 1 and UF = 1

Reading register C clears this bit.

**Register D**

Register D Bits							
7	6	5	4	3	2	1	0
VRT	0	0	0	0	0	0	0

Register D is the read-only data integrity status register.

**Bits 0–6 - Unused Bits**

7	6	5	4	3	2	1	0
-	0	0	0	0	0	0	0

These bits are always set to 0.

**VRT - Valid RAM and Time**

7	6	5	4	3	2	1	0
VRT	-	-	-	-	-	-	-

1 = Valid backup energy source

0 = Backup energy source is depleted

When the backup energy source is depleted (VRT = 0), data integrity of the RTC and storage registers is not guaranteed.

## bq4285

---

### Absolute Maximum Ratings

Symbol	Parameter	Value	Unit	Conditions
V <sub>CC</sub>	DC voltage applied on V <sub>CC</sub> relative to V <sub>SS</sub>	-0.3 to 7.0	V	
V <sub>T</sub>	DC voltage applied on any pin excluding V <sub>CC</sub> relative to V <sub>SS</sub>	-0.3 to 7.0	V	V <sub>T</sub> ≤ V <sub>CC</sub> + 0.3
T <sub>OPR</sub>	Operating temperature	0 to +70	°C	Commercial
T <sub>STG</sub>	Storage temperature	-55 to +125	°C	
T <sub>BIAS</sub>	Temperature under bias	-40 to +85	°C	
T <sub>SOLDER</sub>	Soldering temperature	260	°C	For 10 seconds

**Note:** Permanent device damage may occur if **Absolute Maximum Ratings** are exceeded. Functional operation should be limited to the Recommended DC Operating Conditions detailed in this data sheet. Exposure to conditions beyond the operational limits for extended periods of time may affect device reliability.

### Recommended DC Operating Conditions (T<sub>A</sub> = T<sub>OPR</sub>)

Symbol	Parameter	Minimum	Typical	Maximum	Unit
V <sub>CC</sub>	Supply voltage	4.5	5.0	5.5	V
V <sub>SS</sub>	Supply voltage	0	0	0	V
V <sub>IL</sub>	Input low voltage	-0.3	-	0.8	V
V <sub>IH</sub>	Input high voltage	2.2	-	V <sub>CC</sub> + 0.3	V
V <sub>BC</sub>	Backup cell voltage	2.5	-	4.0	V

**Note:** Typical values indicate operation at T<sub>A</sub> = 25°C.

**DC Electrical Characteristics** ( $T_A = T_{OPR}$ ,  $V_{CC} = 5V \pm 10\%$ )

Symbol	Parameter	Minimum	Typical	Maximum	Unit	Conditions/Notes
$I_{LI}$	Input leakage current	-	-	$\pm 1$	$\mu A$	$V_{IN} = V_{SS}$ to $V_{CC}$
$I_{LO}$	Output leakage current	-	-	$\pm 1$	$\mu A$	$AD_0$ – $AD_7$ , $\overline{INT}$ , and SQW in high impedance, $V_{OUT} = V_{SS}$ to $V_{CC}$
$V_{OH}$	Output high voltage	2.4	-	-	V	$I_{OH} = -2.0$ mA
$V_{OL}$	Output low voltage	-	-	0.4	V	$I_{OL} = 4.0$ mA
$I_{CC}$	Operating supply current	-	7	15	mA	Min. cycle, duty = 100%, $I_{OH} = 0$ mA, $I_{OL} = 0$ mA
$V_{SO}$	Supply switch-over voltage	-	$V_{BC}$	-	V	
$I_{CCB}$	Battery operation current	-	0.3	0.5	$\mu A$	$V_{BC} = 3V$ , $T_A = 25^\circ C$ , no load on $V_{OUT}$ or $CE_{OUT}$
$V_{PFD}$	Power-fail-detect voltage	4.0	4.17	4.35	V	
$V_{OUT1}$	$V_{OUT}$ voltage	$V_{CC} - 0.3V$	-	-	V	$I_{OUT} = 100$ mA, $V_{CC} > V_{BC}$
$V_{OUT2}$	$V_{OUT}$ voltage	$V_{BC} - 0.3V$	-	-	V	$I_{OUT} = 100\mu A$ , $V_{CC} < V_{BC}$
$\overline{I}_{CE}$	Chip enable input current	-	-	100	$\mu A$	Internal 50K pull-up

**Note:** Typical values indicate operation at  $T_A = 25^\circ C$ ,  $V_{CC} = 5V$  or  $V_{BC} = 3V$ .

**Crystal Specifications** (DT-26 or Equivalent)

Symbol	Parameter	Minimum	Typical	Maximum	Unit
$f_0$	Oscillation frequency	-	32.768	-	kHz
$C_L$	Load capacitance	-	6	-	pF
$T_P$	Temperature turnover point	20	25	30	$^\circ C$
$k$	Parabolic curvature constant	-	-	-0.042	ppm/ $^\circ C$
$Q$	Quality factor	40,000	70,000	-	
$R_1$	Series resistance	-	-	45	K $\Omega$
$C_0$	Shunt capacitance	-	1.1	1.8	pF
$C_0/C_1$	Capacitance ratio	-	430	600	
$D_L$	Drive level	-	-	1	$\mu W$
$\Delta f/f_0$	Aging (first year at $25^\circ C$ )	-	1	-	ppm

# bq4285

## Capacitance ( $T_A = 25^\circ\text{C}$ , $F = 1\text{MHz}$ , $V_{CC} = 5.0\text{V}$ )

Symbol	Parameter	Minimum	Typical	Maximum	Unit	Conditions
$C_{I/O}$	Input/output capacitance	-	-	7	pF	$V_{OUT} = 0\text{V}$
$C_{IN}$	Input capacitance	-	-	5	pF	$V_{IN} = 0\text{V}$

**Note:** This parameter is sampled and not 100% tested.

## AC Test Conditions

Parameter	Test Conditions
Input pulse levels	0 to 3.0 V
Input rise and fall times	5 ns
Input and output timing reference levels	1.5 V (unless otherwise specified)
Output load (including scope and jig)	See Figures 5 and 6

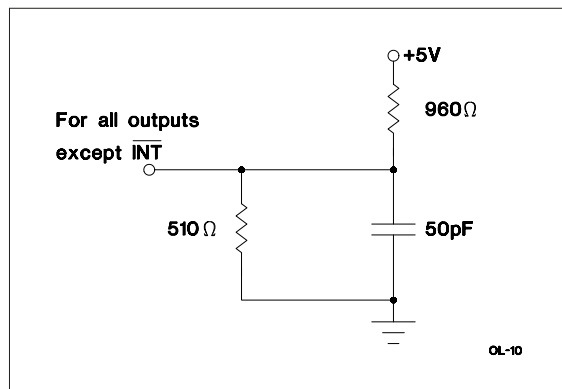

Figure 5. Output Load A

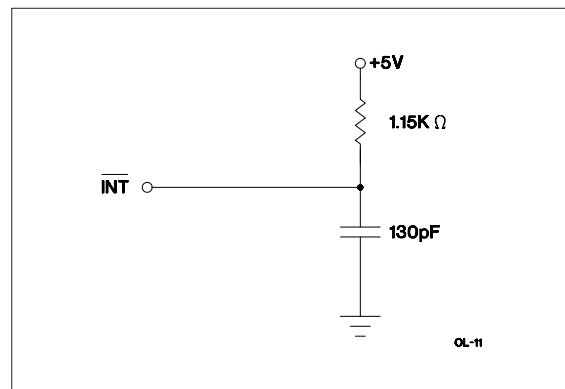

Figure 6. Output Load B

**Read/Write Timing** ( $T_A = T_{OPR}$ ,  $V_{CC} = 5V \pm 10\%$ )

Symbol	Parameter	Minimum	Typical	Maximum	Unit	Notes
t <sub>CYC</sub>	Cycle time	160	-	-	ns	
t <sub>DSL</sub>	DS low or $\overline{RD}/\overline{WR}$ high time	80	-	-	ns	
t <sub>DSH</sub>	DS high or $\overline{RD}/\overline{WR}$ low time	55	-	-	ns	
t <sub>RWH</sub>	$R/\overline{W}$ hold time	0	-	-	ns	
t <sub>RWS</sub>	$R/\overline{W}$ setup time	10	-	-	ns	
t <sub>CS</sub>	Chip select setup time	5	-	-	ns	
t <sub>CH</sub>	Chip select hold time	0	-	-	ns	
t <sub>DHR</sub>	Read data hold time	0	-	25	ns	
t <sub>DHW</sub>	Write data hold time	0	-	-	ns	
t <sub>AS</sub>	Address setup time	20	-	-	ns	
t <sub>AH</sub>	Address hold time	5	-	-	ns	
t <sub>DAS</sub>	Delay time, DS to AS rise	10	-	-	ns	
t <sub>ASW</sub>	Pulse width, AS high	30	-	-	ns	
t <sub>ASD</sub>	Delay time, AS to DS rise ( $\overline{RD}/\overline{WR}$ fall)	35	-	-	ns	
t <sub>OD</sub>	Output data delay time from DS rise ( $\overline{RD}$ fall)	-	-	50	ns	
t <sub>DW</sub>	Write data setup time	30	-	-	ns	
t <sub>BUC</sub>	Delay time before update	-	244	-	$\mu$ s	
t <sub>PI</sub>	Periodic interrupt time interval	-	-	-	-	See Table 3
t <sub>UC</sub>	Time of update cycle	-	1	-	$\mu$ s	

# bq4285

## Motorola Bus Read/Write Timing (PLCC Package Only) Note: OBSOLETE

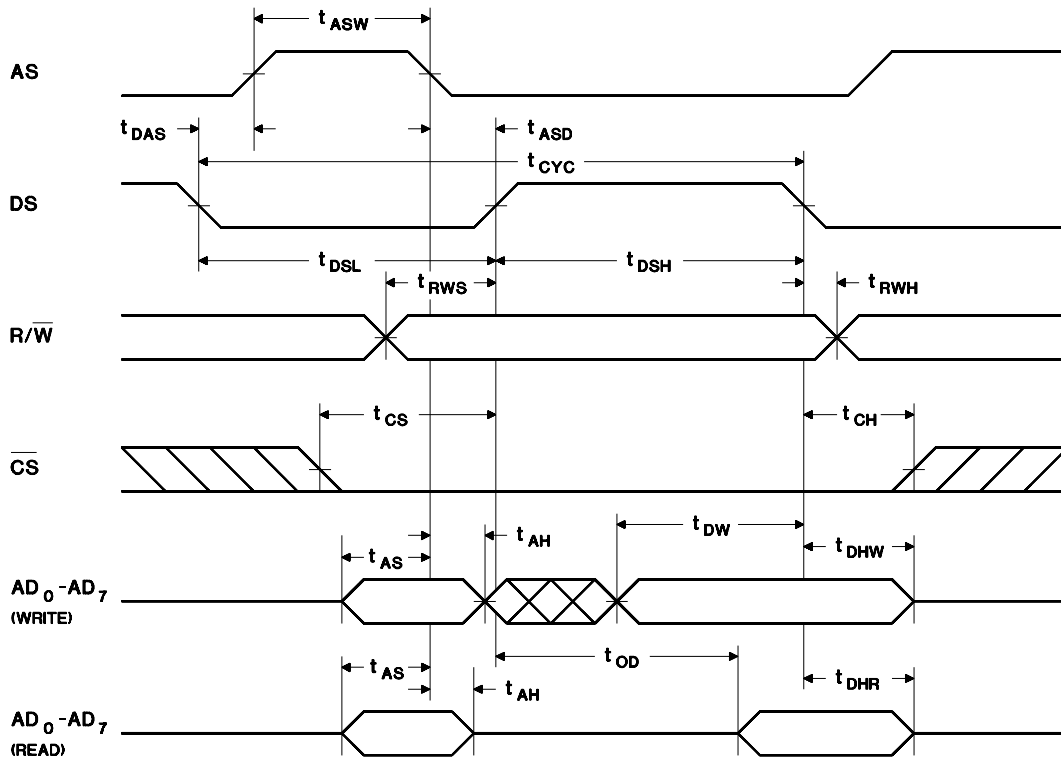

RC-4



Intel Bus Read Timing

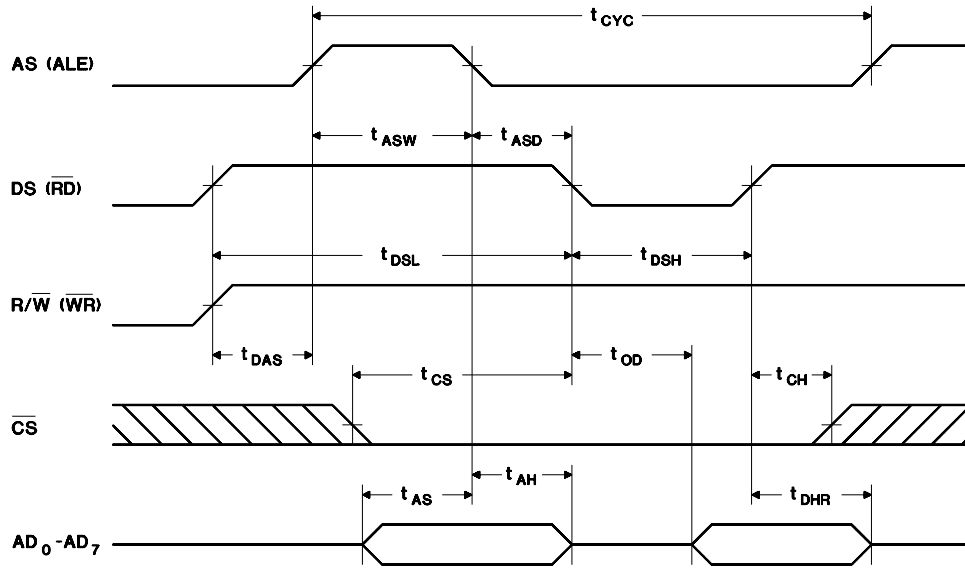

RC-5

Intel Bus Write Timing

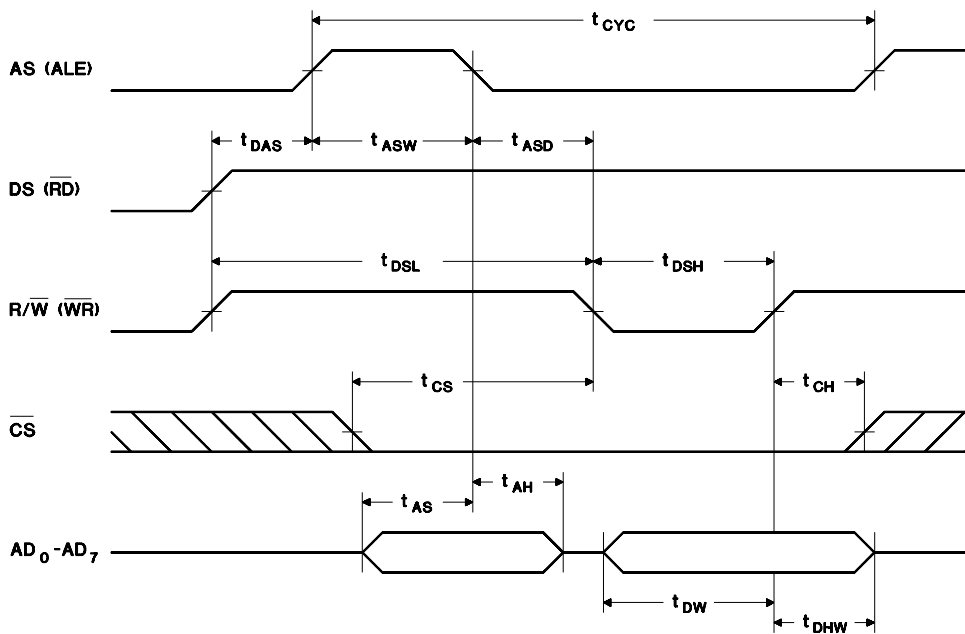

WC-5

# bq4285

## Power-Down/Power-Up Timing ( $T_A = T_{OPR}$ )

Symbol	Parameter	Minimum	Typical	Maximum	Unit	Conditions
$t_F$	$V_{CC}$ slew from 4.5V to 0V	300	-	-	$\mu s$	
$t_R$	$V_{CC}$ slew from 0V to 4.5V	100	-	-	$\mu s$	
$t_{CSR}$	$\overline{CS}$ at $V_{IH}$ after power-up	20	-	200	ms	Internal write-protection period after $V_{CC}$ passes $V_{PFD}$ on power-up.
$t_{WPT}$	Write-protect time for external RAM	10	6	30	$\mu s$	Delay after $V_{CC}$ slews down past $V_{PFD}$ before SRAM is write-protected.
$t_{CER}$	Chip enable recovery time	$t_{CSR}$	-	$t_{CSR}$	ms	Time during which external SRAM is write-protected after $V_{CC}$ passes $V_{PFD}$ on power-up.
$t_{CED}$	Chip enable propagation delay to external SRAM	-	7	10	ns	

**Caution:** Negative undershoots below the absolute maximum rating of -0.3V in battery-backup mode may affect data integrity.

## Power-Down/Power-Up Timing

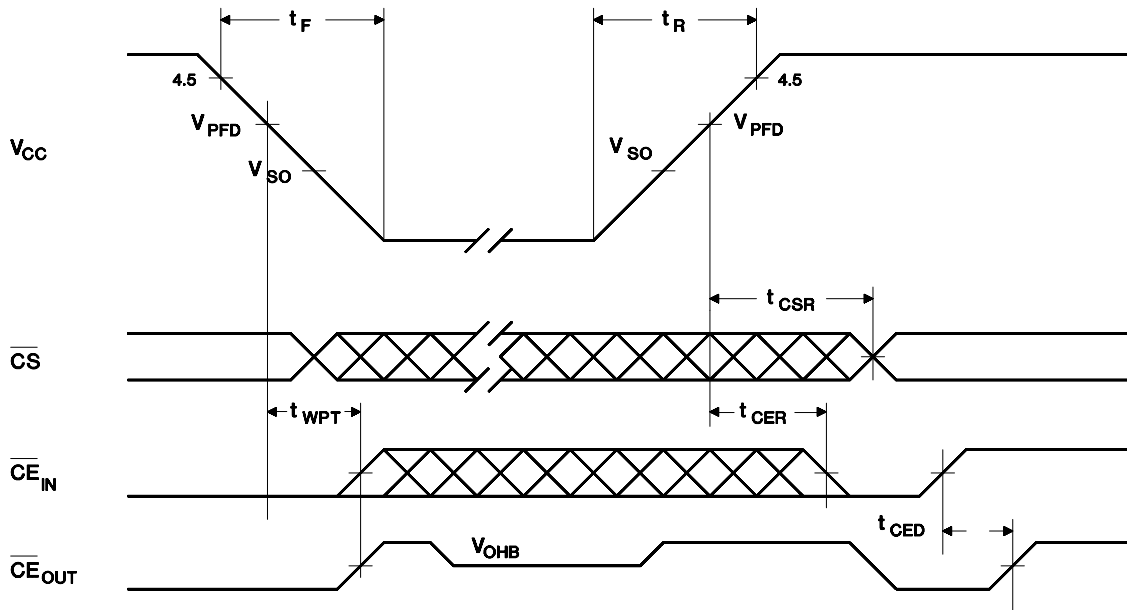

PD-10

**Interrupt Delay Timing (TA = TOPR)**

Symbol	Parameter	Minimum	Typical	Maximum	Unit
t <sub>RSW</sub>	Reset pulse width	5	-	-	μs
t <sub>IRR</sub>	$\overline{\text{INT}}$ release from $\overline{\text{RST}}$	-	-	2	μs
t <sub>IRD</sub>	$\overline{\text{INT}}$ release from DS ( $\overline{\text{RD}}$ )	-	-	2	μs

**Interrupt Delay Timing (PLCC Package Only) Note: Package OBSOLETE**

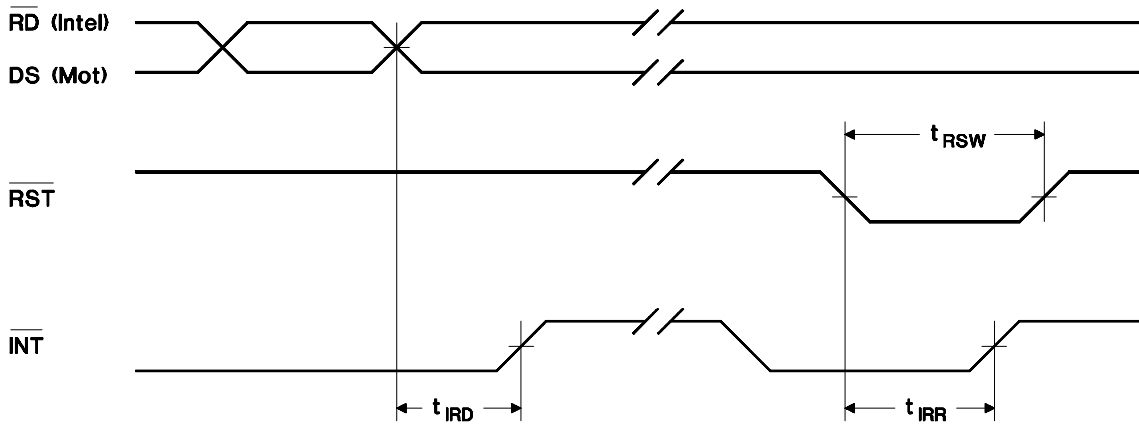

INT-1

**Interrupt Delay Timing**

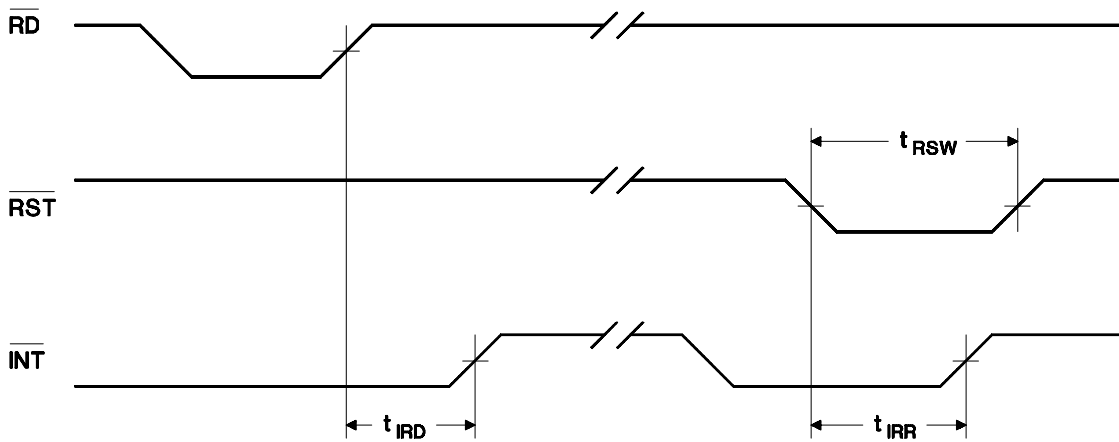

INT-4

# bq4285

## 24-Pin DIP (P)

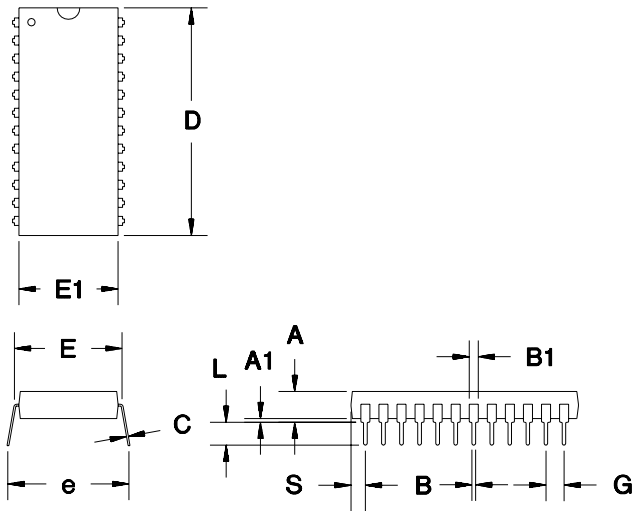

## 24-Pin DIP (P)

Dimension	Minimum	Maximum
A	0.160	0.190
A1	0.015	0.040
B	0.015	0.022
B1	0.045	0.065
C	0.008	0.013
D	1.240	1.280
E	0.600	0.625
E1	0.530	0.570
e	0.600	0.670
G	0.090	0.110
L	0.115	0.150
S	0.070	0.090

All dimensions are in inches.

## 24-Pin SOIC (S)

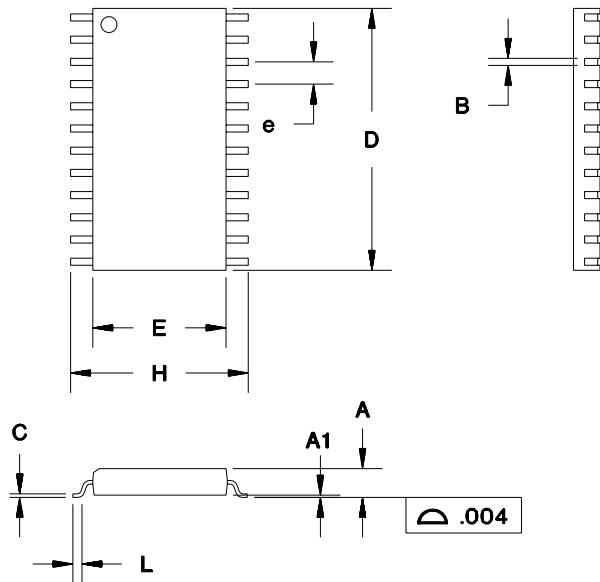

## 24-Pin SOIC (S)

Dimension	Minimum	Maximum
A	0.095	0.105
A1	0.004	0.012
B	0.013	0.020
C	0.008	0.013
D	0.600	0.615
E	0.290	0.305
e	0.045	0.055
H	0.395	0.415
L	0.020	0.040

All dimensions are in inches.

## bq4285

---

### Data Sheet Revision History

Change No.	Page No.	Description	Natur of Change
1	3	Address strobe input	Clarification
1	12	Backup cell voltage $V_{BC}$	Was 2.0 min; is 2.5 min
1	13	Power-fail detect voltage $V_{PFD}$	Was 4.1 min, 4.25 max; is 4.0 min, 4.35 max
1	13	Chip enable input current	Additional specification
2	3, 13	Crystal type Daiwas DT-26 (not DT-26S)	Clarification
3	1, 20, 22	Package option change	PLCC last time buy
4	1, 2, 3, 13, 16, 19, 21, 23	Package option removal	PLCC Last Time Buy Complete

**Note:** Change 1 = Nov. 1992 B changes from June 1991 A.  
Change 2 = Nov. 1993 C changes from Nov. 1992 B  
Change 3 = Jan. 1999 D changes from Nov. 1993 C  
Change 4 = May 2004 (SLUS002A) changes from Jan. 1999 D

## Ordering Information

**bq4285** -

- Temperature:**  
blank = Commercial (0 to +70°C)
- Package Option:**  
P = 24-pin plastic DIP (0.600)  
S = 24-pin SOIC (0.300)
- Device:**  
bq4285 Real-Time Clock With NVRAM Control

**PACKAGING INFORMATION**

Orderable Device	Status <sup>(1)</sup>	Package Type	Package Drawing	Pins	Package Qty	Eco Plan <sup>(2)</sup>	Lead/Ball Finish	MSL Peak Temp <sup>(3)</sup>
BQ4285P-SB2	ACTIVE	PDIP	N	24	15	Pb-Free (RoHS)	A42 SN	N / A for Pkg Type
BQ4285S-SB2	ACTIVE	SOIC	DW	24	25	Green (RoHS & no Sb/Br)	CU NIPDAU	Level-1-260C-UNLIM
BQ4285S-SB2G4	ACTIVE	SOIC	DW	24	25	Green (RoHS & no Sb/Br)	CU NIPDAU	Level-1-260C-UNLIM
BQ4285S-SB2TR	ACTIVE	SOIC	DW	24	2000	Green (RoHS & no Sb/Br)	CU NIPDAU	Level-1-260C-UNLIM
BQ4285S-SB2TRG4	ACTIVE	SOIC	DW	24	2000	Green (RoHS & no Sb/Br)	CU NIPDAU	Level-1-260C-UNLIM

<sup>(1)</sup> The marketing status values are defined as follows:

**ACTIVE:** Product device recommended for new designs.

**LIFEBUY:** TI has announced that the device will be discontinued, and a lifetime-buy period is in effect.

**NRND:** Not recommended for new designs. Device is in production to support existing customers, but TI does not recommend using this part in a new design.

**PREVIEW:** Device has been announced but is not in production. Samples may or may not be available.

**OBSOLETE:** TI has discontinued the production of the device.

<sup>(2)</sup> Eco Plan - The planned eco-friendly classification: Pb-Free (RoHS), Pb-Free (RoHS Exempt), or Green (RoHS & no Sb/Br) - please check <http://www.ti.com/productcontent> for the latest availability information and additional product content details.

**TBD:** The Pb-Free/Green conversion plan has not been defined.

**Pb-Free (RoHS):** TI's terms "Lead-Free" or "Pb-Free" mean semiconductor products that are compatible with the current RoHS requirements for all 6 substances, including the requirement that lead not exceed 0.1% by weight in homogeneous materials. Where designed to be soldered at high temperatures, TI Pb-Free products are suitable for use in specified lead-free processes.

**Pb-Free (RoHS Exempt):** This component has a RoHS exemption for either 1) lead-based flip-chip solder bumps used between the die and package, or 2) lead-based die adhesive used between the die and leadframe. The component is otherwise considered Pb-Free (RoHS compatible) as defined above.

**Green (RoHS & no Sb/Br):** TI defines "Green" to mean Pb-Free (RoHS compatible), and free of Bromine (Br) and Antimony (Sb) based flame retardants (Br or Sb do not exceed 0.1% by weight in homogeneous material)

<sup>(3)</sup> MSL, Peak Temp. -- The Moisture Sensitivity Level rating according to the JEDEC industry standard classifications, and peak solder temperature.

**Important Information and Disclaimer:**The information provided on this page represents TI's knowledge and belief as of the date that it is provided. TI bases its knowledge and belief on information provided by third parties, and makes no representation or warranty as to the accuracy of such information. Efforts are underway to better integrate information from third parties. TI has taken and continues to take reasonable steps to provide representative and accurate information but may not have conducted destructive testing or chemical analysis on incoming materials and chemicals. TI and TI suppliers consider certain information to be proprietary, and thus CAS numbers and other limited information may not be available for release.

In no event shall TI's liability arising out of such information exceed the total purchase price of the TI part(s) at issue in this document sold by TI to Customer on an annual basis.

**TAPE AND REEL INFORMATION**

**QUADRANT ASSIGNMENTS FOR PIN 1 ORIENTATION IN TAPE**

\*All dimensions are nominal

Device	Package Type	Package Drawing	Pins	SPQ	Reel Diameter (mm)	Reel Width W1 (mm)	A0 (mm)	B0 (mm)	K0 (mm)	P1 (mm)	W (mm)	Pin1 Quadrant
BQ4285S-SB2TR	SOIC	DW	24	2000	330.0	24.4	10.75	15.7	2.7	12.0	24.0	Q1



TAPE AND REEL BOX DIMENSIONS



\*All dimensions are nominal

Device	Package Type	Package Drawing	Pins	SPQ	Length (mm)	Width (mm)	Height (mm)
BQ4285S-SB2TR	SOIC	DW	24	2000	367.0	367.0	45.0

N (R-PDIP-T24)

PLASTIC DUAL-IN-LINE

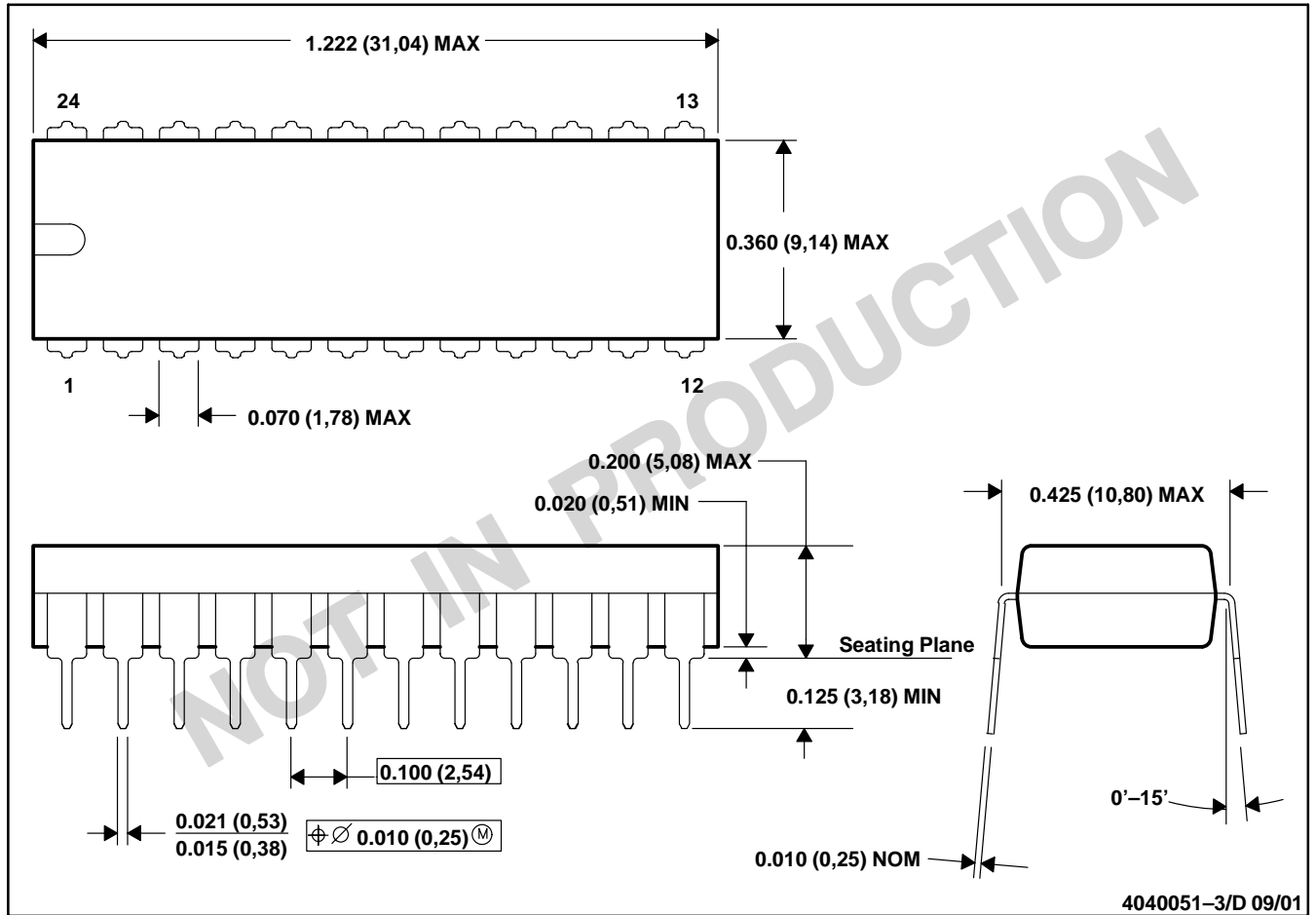

- NOTES: A. All linear dimensions are in inches (millimeters).  
 B. This drawing is subject to change without notice.  
 C. Falls within JEDEC MS-010

**N (R-PDIP-T\*\*)**

**PLASTIC DUAL-IN-LINE PACKAGE**

24 PIN SHOWN



- NOTES: A. All linear dimensions are in inches (millimeters).  
 B. This drawing is subject to change without notice.  
 C. Falls within JEDEC MS-011  
 D. Falls within JEDEC MS-015 (32 pin only)

DW (R-PDSO-G24)

PLASTIC SMALL OUTLINE



- NOTES:
- A. All linear dimensions are in inches (millimeters). Dimensioning and tolerancing per ASME Y14.5M-1994.
  - B. This drawing is subject to change without notice.
  - C. Body dimensions do not include mold flash or protrusion not to exceed 0.006 (0,15).
  - D. Falls within JEDEC MS-013 variation AD.

## IMPORTANT NOTICE

Texas Instruments Incorporated and its subsidiaries (TI) reserve the right to make corrections, enhancements, improvements and other changes to its semiconductor products and services per JESD46, latest issue, and to discontinue any product or service per JESD48, latest issue. Buyers should obtain the latest relevant information before placing orders and should verify that such information is current and complete. All semiconductor products (also referred to herein as "components") are sold subject to TI's terms and conditions of sale supplied at the time of order acknowledgment.

TI warrants performance of its components to the specifications applicable at the time of sale, in accordance with the warranty in TI's terms and conditions of sale of semiconductor products. Testing and other quality control techniques are used to the extent TI deems necessary to support this warranty. Except where mandated by applicable law, testing of all parameters of each component is not necessarily performed.

TI assumes no liability for applications assistance or the design of Buyers' products. Buyers are responsible for their products and applications using TI components. To minimize the risks associated with Buyers' products and applications, Buyers should provide adequate design and operating safeguards.

TI does not warrant or represent that any license, either express or implied, is granted under any patent right, copyright, mask work right, or other intellectual property right relating to any combination, machine, or process in which TI components or services are used. Information published by TI regarding third-party products or services does not constitute a license to use such products or services or a warranty or endorsement thereof. Use of such information may require a license from a third party under the patents or other intellectual property of the third party, or a license from TI under the patents or other intellectual property of TI.

Reproduction of significant portions of TI information in TI data books or data sheets is permissible only if reproduction is without alteration and is accompanied by all associated warranties, conditions, limitations, and notices. TI is not responsible or liable for such altered documentation. Information of third parties may be subject to additional restrictions.

Resale of TI components or services with statements different from or beyond the parameters stated by TI for that component or service voids all express and any implied warranties for the associated TI component or service and is an unfair and deceptive business practice. TI is not responsible or liable for any such statements.

Buyer acknowledges and agrees that it is solely responsible for compliance with all legal, regulatory and safety-related requirements concerning its products, and any use of TI components in its applications, notwithstanding any applications-related information or support that may be provided by TI. Buyer represents and agrees that it has all the necessary expertise to create and implement safeguards which anticipate dangerous consequences of failures, monitor failures and their consequences, lessen the likelihood of failures that might cause harm and take appropriate remedial actions. Buyer will fully indemnify TI and its representatives against any damages arising out of the use of any TI components in safety-critical applications.

In some cases, TI components may be promoted specifically to facilitate safety-related applications. With such components, TI's goal is to help enable customers to design and create their own end-product solutions that meet applicable functional safety standards and requirements. Nonetheless, such components are subject to these terms.

No TI components are authorized for use in FDA Class III (or similar life-critical medical equipment) unless authorized officers of the parties have executed a special agreement specifically governing such use.

Only those TI components which TI has specifically designated as military grade or "enhanced plastic" are designed and intended for use in military/aerospace applications or environments. Buyer acknowledges and agrees that any military or aerospace use of TI components which have **not** been so designated is solely at the Buyer's risk, and that Buyer is solely responsible for compliance with all legal and regulatory requirements in connection with such use.

TI has specifically designated certain components as meeting ISO/TS16949 requirements, mainly for automotive use. In any case of use of non-designated products, TI will not be responsible for any failure to meet ISO/TS16949.

### Products

Audio	<a href="http://www.ti.com/audio">www.ti.com/audio</a>
Amplifiers	<a href="http://amplifier.ti.com">amplifier.ti.com</a>
Data Converters	<a href="http://dataconverter.ti.com">dataconverter.ti.com</a>
DLP® Products	<a href="http://www.dlp.com">www.dlp.com</a>
DSP	<a href="http://dsp.ti.com">dsp.ti.com</a>
Clocks and Timers	<a href="http://www.ti.com/clocks">www.ti.com/clocks</a>
Interface	<a href="http://interface.ti.com">interface.ti.com</a>
Logic	<a href="http://logic.ti.com">logic.ti.com</a>
Power Mgmt	<a href="http://power.ti.com">power.ti.com</a>
Microcontrollers	<a href="http://microcontroller.ti.com">microcontroller.ti.com</a>
RFID	<a href="http://www.ti-rfid.com">www.ti-rfid.com</a>
OMAP Applications Processors	<a href="http://www.ti.com/omap">www.ti.com/omap</a>
Wireless Connectivity	<a href="http://www.ti.com/wirelessconnectivity">www.ti.com/wirelessconnectivity</a>

### Applications

Automotive and Transportation	<a href="http://www.ti.com/automotive">www.ti.com/automotive</a>
Communications and Telecom	<a href="http://www.ti.com/communications">www.ti.com/communications</a>
Computers and Peripherals	<a href="http://www.ti.com/computers">www.ti.com/computers</a>
Consumer Electronics	<a href="http://www.ti.com/consumer-apps">www.ti.com/consumer-apps</a>
Energy and Lighting	<a href="http://www.ti.com/energy">www.ti.com/energy</a>
Industrial	<a href="http://www.ti.com/industrial">www.ti.com/industrial</a>
Medical	<a href="http://www.ti.com/medical">www.ti.com/medical</a>
Security	<a href="http://www.ti.com/security">www.ti.com/security</a>
Space, Avionics and Defense	<a href="http://www.ti.com/space-avionics-defense">www.ti.com/space-avionics-defense</a>
Video and Imaging	<a href="http://www.ti.com/video">www.ti.com/video</a>

### TI E2E Community

[e2e.ti.com](http://e2e.ti.com)