

## ADVANCED REGULATING PULSE WIDTH MODULATORS

### FEATURES

- Complete PWM Power Control Circuitry
- Uncommitted Outputs for Single-Ended or Push-Pull Applications
- Low Standby Current . . . 8 mA Typical
- Interchangeable With SG1524, SG2524 and SG3524, Respectively

### DESCRIPTION

The UC1524, UC2524 and UC3524 incorporate on a single monolithic chip all the functions required for the construction of regulating power supplies, inverters or switching regulators. They can also be used as the control element for high-power-output applications. The UC1524 family was designed for switching regulators of either polarity, transformer-coupled dc-to-dc converters, transformerless voltage doublers and polarity converter applications employing fixed-frequency, pulse-width modulation techniques. The dual alternating outputs allow either single-ended or push-pull applications. Each device includes an on-chip reference, error amplifier, programmable oscillator, pulse-steering flip-flop, two uncommitted output transistors, a high-gain comparator, and current-limiting and shut-down circuitry. The UC1524 is characterized for operation over the full military temperature range of  $-55^{\circ}\text{C}$  to  $125^{\circ}\text{C}$ . The UC2524 and UC3524 are designed for operation from  $-25^{\circ}\text{C}$  to  $85^{\circ}\text{C}$  and  $0^{\circ}\text{C}$  to  $70^{\circ}\text{C}$ , respectively.

### BLOCK DIAGRAM

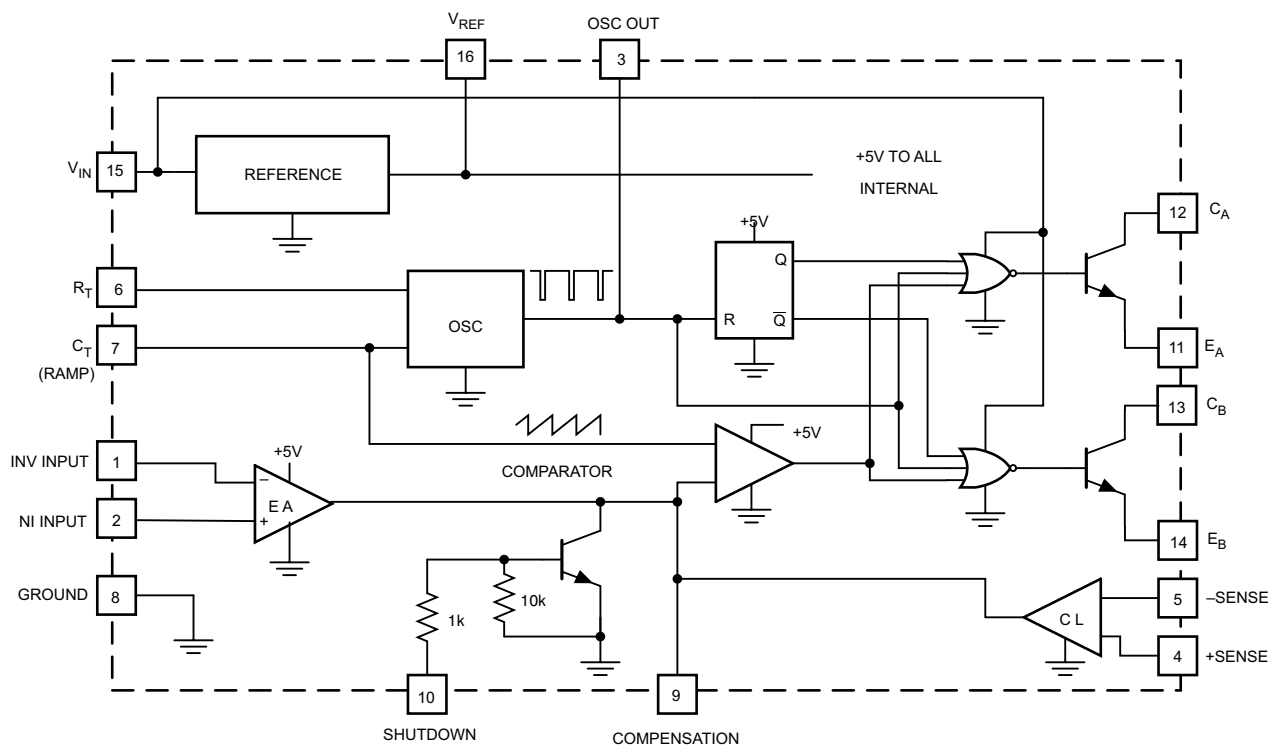

Please be aware that an important notice concerning availability, standard warranty, and use in critical applications of Texas Instruments semiconductor products and disclaimers thereto appears at the end of this data sheet.

### CONNECTION DIAGRAM

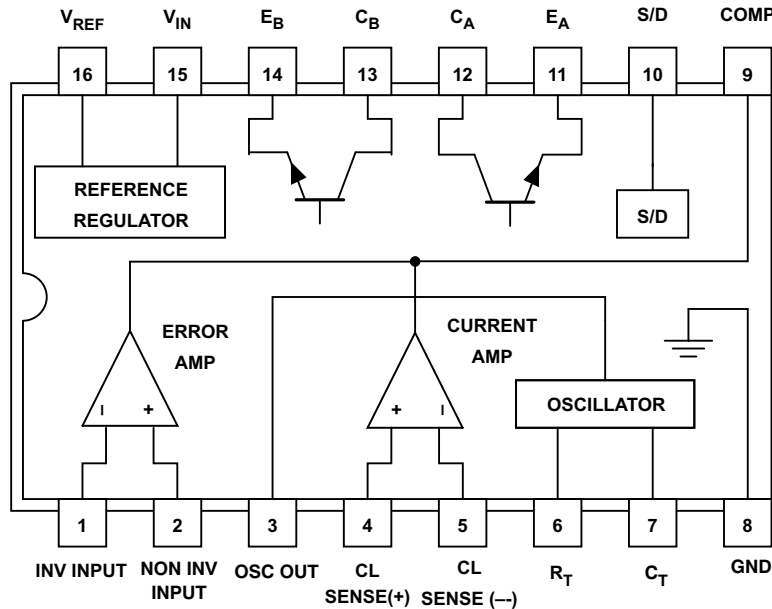

### ABSOLUTE MAXIMUM RATINGS

over operating free-air temperature range (unless otherwise noted)

|                   |   | UNIT            |
|-------------------|---|-----------------|
| $V_{CC}$          | Supply voltage <sup>(1)(2)</sup>            | 40 V            |
|                   | Collector output current                    | 100 mA          |
|                   | Reference output current                    | 50 mA           |
|                   | Current through $C_T$ terminal <sup>g</sup> | -50 mA          |
| Power dissipation | $T_A = 25^\circ\text{C}^{(3)}$              | 1000 mW         |
|                   | $T_C = 25^\circ\text{C}^{(3)}$              | 2000 mW         |
|                   | Operating junction temperature range        | -55°C to 150°C  |
|                   | Storage temperature range                   | -65°C to +150°C |

- (1) All voltage values are with respect to the ground terminal, pin 8.
- (2) The reference regulator may be bypassed for operation from a fixed 5 V supply by connecting the  $V_{CC}$  and reference output pins both to the supply voltage. In this configuration the maximum supply voltage is 6 V.
- (3) Consult packaging section of data book for thermal limitations and considerations of package.

### RECOMMENDED OPERATING CONDITIONS

over operating free-air temperature range (unless otherwise noted)

|                                     |                                | MIN   | NOM | MAX | UNIT          |
|-------------------------------------|--------------------------------|-------|-----|-----|---------------|
| $V_{CC}$                            | Supply voltage                 | 8     |     | 40  | V             |
|                                     | Reference output current       | 0     |     | 20  | mA            |
|                                     | Current through $C_T$ terminal | -0.03 |     | -2  | mA            |
| $R_T$                               | Timing resistor                | 1.8   |     | 100 | k $\Omega$    |
| $C_T$                               | Timing capacitor               | 0.001 |     | 0.1 | $\mu\text{F}$ |
| Operating ambient temperature range | UC1524                         | -55   |     | 125 | °C            |
|                                     | UC2524                         | -25   |     | 85  |               |
|                                     | UC3524                         | 0     |     | 70  |               |

## ELECTRICAL CHARACTERISTICS

these specifications apply for  $T_A = -55^\circ\text{C}$  to  $125^\circ\text{C}$  for the UC1524,  $-25^\circ\text{C}$  to  $85^\circ\text{C}$  for the UC2524, and  $0^\circ\text{C}$  to  $70^\circ\text{C}$  for the UC3524,  $V_{IN} = 20\text{ V}$ , and  $f = 20\text{ kHz}$ ,  $T_A = T_J$ , over operating free-air temperature range (unless otherwise noted)

| PARAMETER                           | TEST CONDITIONS   | UC1524/UC2524 |      |     | UC3524 |      |     | UNIT                 |
|-------------------------------------|---|---------------|------|-----|--------|------|-----|----------------------|
|                                     |   | MIN           | TYP  | MAX | MIN    | TYP  | MAX |                      |
| <b>REFERENCE SECTION</b>            |   |               |      |     |        |      |     |                      |
| Output voltage                      |   | 4.8           | 5.0  | 5.2 | 4.6    | 5.0  | 5.4 | V                    |
| Line regulation                     | $V_{IN} = 8\text{ V to }40\text{ V}$  |               | 10   | 20  |        | 10   | 30  | mV                   |
| Load regulation                     | $I_L = 0\text{ mA to }20\text{ mA}$   |               | 20   | 50  |        | 20   | 50  | mV                   |
| Ripple rejection                    | $f = 120\text{ Hz}$ , $T_J = 25^\circ\text{C}$  |               | 66   |     |        | 66   |     | dB                   |
| Short circuit current limit         | $V_{REF} = 0$ , $T_J = 25^\circ\text{C}$  |               | 100  |     |        | 100  |     | mA                   |
| Temperature stability               | Over operating temperature range  |               | 0.3% | 1%  |        | 0.3% | 1%  |                      |
| Long term stability                 | $T_J = 125^\circ\text{C}$ , $t = 1000\text{ Hrs}$                                       |               | 20   |     |        | 20   |     | mV                   |
| <b>OSCILLATOR SECTION</b>           |   |               |      |     |        |      |     |                      |
| Maximum frequency                   | $C_T = 1\text{ nF}$ , $R_T = 2\text{ k}\Omega$  |               | 300  |     |        | 300  |     | kHz                  |
| Initial accuracy                    | $R_T$ and $C_T$ constant  |               | 5%   |     |        | 5%   |     |                      |
| Voltage stability                   | $V_{IN} = 8\text{ V to }40\text{ V}$ , $T_J = 25^\circ\text{C}$                         |               |      | 1%  |        |      | 1%  |                      |
| Temperature stability               | Over operating temperature range  |               |      | 5%  |        |      | 5%  |                      |
| Output amplitude                    | Pin 3, $T_J = 25^\circ\text{C}$   |               | 3.5  |     |        | 3.5  |     | V                    |
| Output pulse width                  | $C_T = 0.01\text{ mfd}$ , $T_J = 25^\circ\text{C}$                                      |               | 0.5  |     |        | 0.5  |     | $\mu\text{s}$        |
| <b>ERROR AMPLIFIER SECTION</b>      |   |               |      |     |        |      |     |                      |
| Input offset voltage                | $V_{CM} = 2.5\text{ V}$   |               | 0.5  | 5   |        | 2    | 10  | mV                   |
| Input bias current                  | $V_{CM} = 2.5\text{ V}$   |               | 2    | 10  |        | 2    | 10  | $\mu\text{A}$        |
| Open loop voltage gain              |   | 72            | 80   |     | 60     | 80   |     | dB                   |
| Common mode voltage                 | $T_J = 25^\circ\text{C}$  | 1.8           |      | 3.4 | 1.8    |      | 3.4 | V                    |
| Common mode rejection ratio         | $T_J = 25^\circ\text{C}$  |               | 70   |     |        | 70   |     | dB                   |
| Small signal bandwidth              | $A_V = 0\text{ dB}$ , $T_J = 25^\circ\text{C}$  |               | 3    |     |        | 3    |     | MHz                  |
| Output voltage                      | $T_J = 25^\circ\text{C}$  | 0.5           |      | 3.8 | 0.5    |      | 3.8 | V                    |
| <b>COMPARATOR SECTION</b>           |   |               |      |     |        |      |     |                      |
| Duty-cycle                          | % Each output on  | 0%            |      | 45% | 0%     |      | 45% |                      |
| Input threshold                     | Zero duty-cycle   |               | 1    |     |        | 1    |     | V                    |
|                                     | Maximum duty-cycle  |               | 3.5  |     |        | 3.5  |     |                      |
| Input bias current                  |   |               | 1    |     |        | 1    |     | $\mu\text{A}$        |
| <b>CURRENT LIMITING SECTION</b>     |   |               |      |     |        |      |     |                      |
| Sense voltage                       | Pin 9 = 2 V with error amplifier set for maximum out, $T_J = 25^\circ\text{C}$          | 190           | 200  | 210 | 180    | 200  | 220 | mV                   |
| Sense voltage T.C.                  |   |               | 0.2  |     |        | 0.2  |     | mV/ $^\circ\text{C}$ |
| Common mode voltage                 | $T_J = -55^\circ\text{C to }85^\circ\text{C}$ for the $-1\text{ V to }1\text{ V}$ limit | -1            |      | 1   | -1     |      | 1   | V                    |
|                                     | $T_J = 25^\circ\text{C}$  | -0.3          |      | 1   |        |      |     |                      |
| <b>OUTPUT SECTION (EACH OUTPUT)</b> |   |               |      |     |        |      |     |                      |
| Collector-emitter voltage           |   | 40            |      |     | 40     |      |     | V                    |
| Collector leakage current           | $V_{CE} = 40\text{ V}$  |               | 0.1  | 50  |        | 0.1  | 50  | $\mu\text{A}$        |
| Saturation voltage                  | $I_C = 50\text{ mA}$  |               | 1    | 2   |        | 1    | 2   | V                    |
| Emitter output voltage              | $V_{IN} = 20\text{ V}$  | 17            | 18   |     | 17     | 18   |     | V                    |
| Rise Time                           | $R_C = 2\text{ k}\Omega$ , $T_J = 25^\circ\text{C}$                                     |               | 0.2  |     |        | 0.2  |     | $\mu\text{s}$        |
| Fall Time                           | $R_C = 2\text{ k}\Omega$ , $T_J = 25^\circ\text{C}$                                     |               | 0.1  |     |        | 0.1  |     | $\mu\text{s}$        |
| Total standby current (Note)        | $V_{IN} = 40\text{ V}$  |               | 8    | 10  |        | 8    | 10  | mA                   |

## PRINCIPLES OF OPERATION

The UC1524 is a fixed-frequency pulse-width-modulation voltage regulator control circuit. The regulator operates at a frequency that is programmed by one timing resistor ( $R_T$ ), and one timing capacitor ( $C_T$ ).  $R_T$  establishes a constant charging current for  $C_T$ . This results in a linear voltage ramp at  $C_T$ , which is fed to the comparator providing linear control of the output pulse width by the error amplifier. The UC1524 contains an on-board 5 V regulator that serves as a reference as well as powering the UC1524's internal control circuitry and is also useful in supplying external support functions. This reference voltage is lowered externally by a resistor divider to provide a reference within the common-mode range of the error amplifier or an external reference may be used. The power supply output is sensed by a second resistor divider network to generate a feedback signal to the error amplifier. The amplifier output voltage is then compared to the linear voltage ramp at  $C_T$ . The resulting modulated pulse out of the high-gain comparator is then steered to the appropriate output pass transistor ( $Q_1$  or  $Q_2$ ) by the pulse-steering

flip-flop, which is synchronously toggled by the oscillator output. The oscillator output pulse also serves as a blanking pulse to assure both outputs are never on simultaneously during the transition times. The width of the blanking pulse is controlled by the value of  $C_T$ . The outputs may be applied in a push-pull configuration in which their frequency is half that of the base oscillator. Note that for buck regulator topologies, the two outputs can be wire-ORed for an effective 0-90% duty cycle range. With this connection, the output frequency is the same as the oscillator frequency. The output of the error amplifier shares a common input to the comparator with the current limiting and shutdown circuitry and can be overridden by signals from either of these inputs. This common point is also available externally and may be employed to control the gain of, or to compensate, the error amplifier or to provide additional control to the regulator.

## TYPICAL CHARACTERISTICS

**OPEN-LOOP VOLTAGE AMPLIFICATION  
 OF ERROR AMPLIFIER  
 VS  
 FREQUENCY**

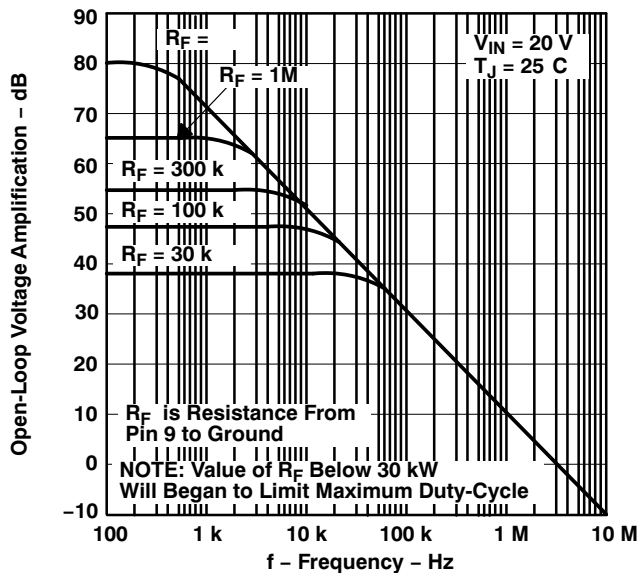

Figure 1.

**OSCILLATOR FREQUENCY  
 VS  
 TIMING COMPONENTS**

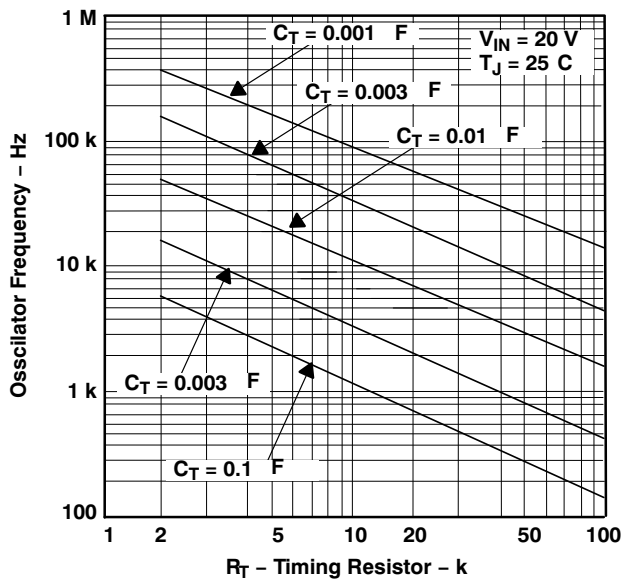

Figure 2.

**OUTPUT DEAD TIME  
 VS  
 TIMING CAPACITANCE VALUE**

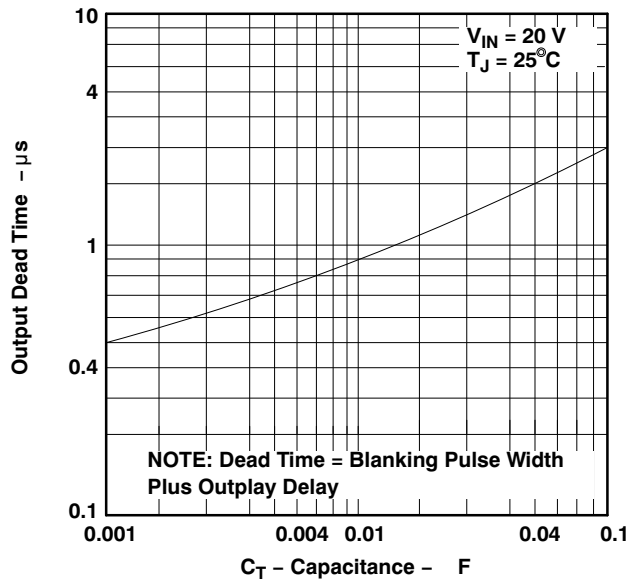

Figure 3.

**OUTPUT SATURATION VOLTAGE  
 VS  
 LOAD CURRENT**

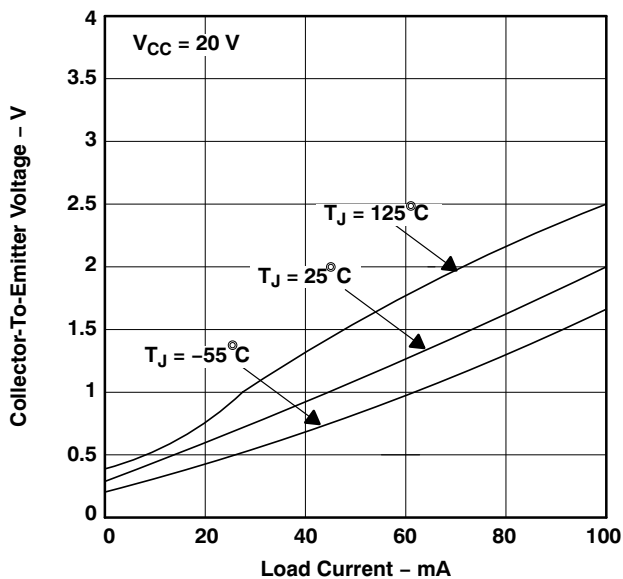

Figure 4.



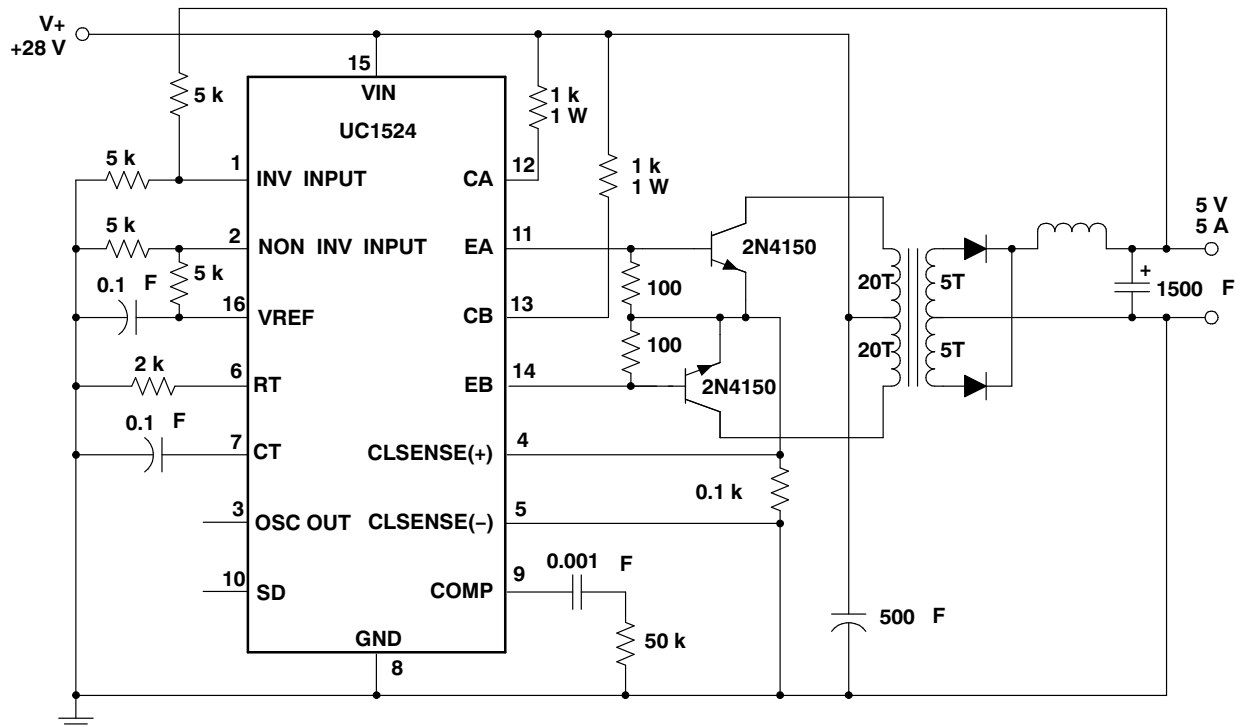

Figure 7. Push-Pull Transformer Coupled Circuit

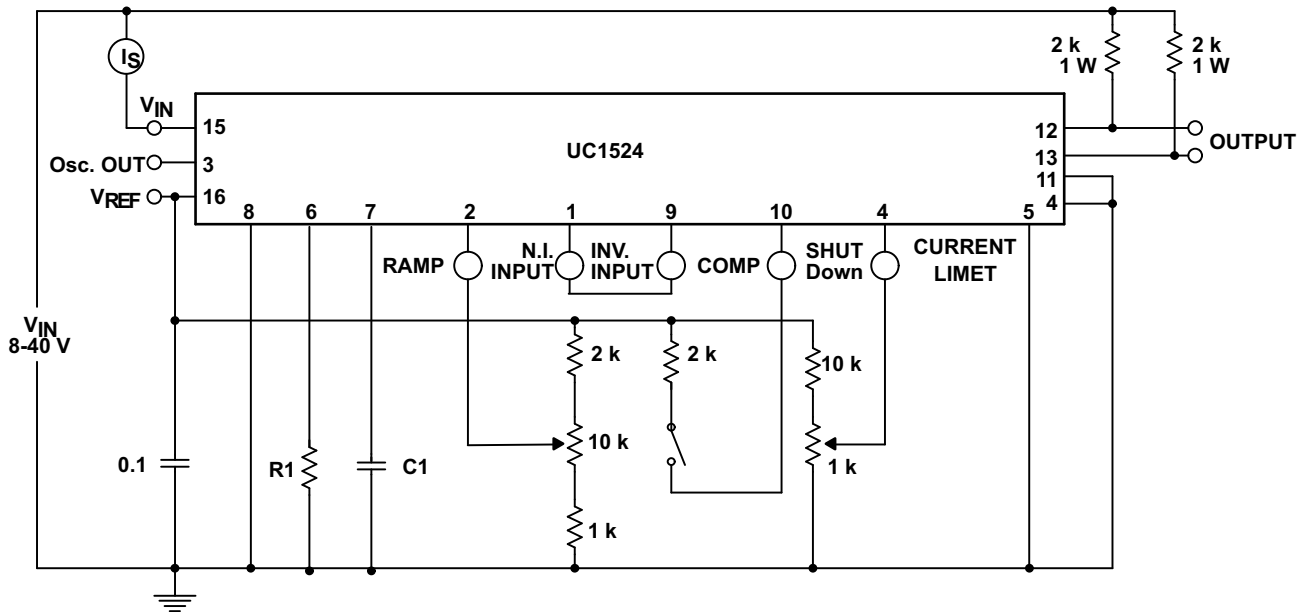

Figure 8. Open Loop Test Circuit

**PACKAGING INFORMATION**

| Orderable Device | Status<br>(1) | Package Type | Package Drawing | Pins | Package Qty | Eco Plan<br>(2)         | Lead/Ball Finish | MSL Peak Temp<br>(3) | Op Temp (°C) | Top-Side Markings<br>(4) | Samples                 |
|------------------|---------------|--------------|-----------------|------|-------------|-------------------------|------------------|----------------------|--------------|--------------------------|-------------------------|
| UC1524J          | OBSOLETE      | CDIP         | J               | 16   |             | TBD                     | Call TI          | Call TI              | -55 to 125   |                          |                         |
| UC1524J/80937    | OBSOLETE      | CDIP         | J               | 16   |             | TBD                     | Call TI          | Call TI              | -55 to 125   |                          |                         |
| UC1524J883B      | OBSOLETE      | CDIP         | J               | 16   |             | TBD                     | Call TI          | Call TI              | -55 to 125   |                          |                         |
| UC2524DW         | ACTIVE        | SOIC         | DW              | 16   | 40          | Green (RoHS & no Sb/Br) | CU NIPDAU        | Level-2-260C-1 YEAR  | -25 to 85    | UC2524DW                 | <a href="#">Samples</a> |
| UC2524DWG4       | ACTIVE        | SOIC         | DW              | 16   | 40          | Green (RoHS & no Sb/Br) | CU NIPDAU        | Level-2-260C-1 YEAR  | -25 to 85    | UC2524DW                 | <a href="#">Samples</a> |
| UC2524J          | OBSOLETE      | CDIP         | J               | 16   |             | TBD                     | Call TI          | Call TI              | -25 to 85    |                          |                         |
| UC2524N          | ACTIVE        | PDIP         | N               | 16   | 25          | Green (RoHS & no Sb/Br) | CU NIPDAU        | N / A for Pkg Type   | -25 to 85    | UC2524N                  | <a href="#">Samples</a> |
| UC2524NG4        | ACTIVE        | PDIP         | N               | 16   | 25          | Green (RoHS & no Sb/Br) | CU NIPDAU        | N / A for Pkg Type   | -25 to 85    | UC2524N                  | <a href="#">Samples</a> |
| UC3524-W         | ACTIVE        | WAFERSALE    | YS              | 0    |             | TBD                     | Call TI          | Call TI              |              |                          | <a href="#">Samples</a> |
| UC3524D          | ACTIVE        | SOIC         | D               | 16   | 40          | Green (RoHS & no Sb/Br) | CU NIPDAU        | Level-2-260C-1 YEAR  | 0 to 70      | UC3524D                  | <a href="#">Samples</a> |
| UC3524DG4        | ACTIVE        | SOIC         | D               | 16   | 40          | Green (RoHS & no Sb/Br) | CU NIPDAU        | Level-2-260C-1 YEAR  | 0 to 70      | UC3524D                  | <a href="#">Samples</a> |
| UC3524DW         | ACTIVE        | SOIC         | DW              | 16   | 40          | Green (RoHS & no Sb/Br) | CU NIPDAU        | Level-2-260C-1 YEAR  | 0 to 70      | UC3524DW                 | <a href="#">Samples</a> |
| UC3524DWG4       | ACTIVE        | SOIC         | DW              | 16   | 40          | Green (RoHS & no Sb/Br) | CU NIPDAU        | Level-2-260C-1 YEAR  | 0 to 70      | UC3524DW                 | <a href="#">Samples</a> |
| UC3524DWTR       | ACTIVE        | SOIC         | DW              | 16   | 2000        | Green (RoHS & no Sb/Br) | CU NIPDAU        | Level-2-260C-1 YEAR  | 0 to 70      | UC3524DW                 | <a href="#">Samples</a> |
| UC3524DWTRG4     | ACTIVE        | SOIC         | DW              | 16   | 2000        | Green (RoHS & no Sb/Br) | CU NIPDAU        | Level-2-260C-1 YEAR  | 0 to 70      | UC3524DW                 | <a href="#">Samples</a> |
| UC3524J          | OBSOLETE      | CDIP         | J               | 16   |             | TBD                     | Call TI          | Call TI              | 0 to 70      |                          |                         |
| UC3524N          | ACTIVE        | PDIP         | N               | 16   | 25          | Green (RoHS & no Sb/Br) | CU NIPDAU        | N / A for Pkg Type   | 0 to 70      | UC3524N                  | <a href="#">Samples</a> |
| UC3524NG4        | ACTIVE        | PDIP         | N               | 16   | 25          | Green (RoHS & no Sb/Br) | CU NIPDAU        | N / A for Pkg Type   | 0 to 70      | UC3524N                  | <a href="#">Samples</a> |

(1) The marketing status values are defined as follows:  
**ACTIVE:** Product device recommended for new designs.



**LIFEBUY:** TI has announced that the device will be discontinued, and a lifetime-buy period is in effect.

**NRND:** Not recommended for new designs. Device is in production to support existing customers, but TI does not recommend using this part in a new design.

**PREVIEW:** Device has been announced but is not in production. Samples may or may not be available.

**OBSOLETE:** TI has discontinued the production of the device.

<sup>(2)</sup> Eco Plan - The planned eco-friendly classification: Pb-Free (RoHS), Pb-Free (RoHS Exempt), or Green (RoHS & no Sb/Br) - please check <http://www.ti.com/productcontent> for the latest availability information and additional product content details.

**TBD:** The Pb-Free/Green conversion plan has not been defined.

**Pb-Free (RoHS):** TI's terms "Lead-Free" or "Pb-Free" mean semiconductor products that are compatible with the current RoHS requirements for all 6 substances, including the requirement that lead not exceed 0.1% by weight in homogeneous materials. Where designed to be soldered at high temperatures, TI Pb-Free products are suitable for use in specified lead-free processes.

**Pb-Free (RoHS Exempt):** This component has a RoHS exemption for either 1) lead-based flip-chip solder bumps used between the die and package, or 2) lead-based die adhesive used between the die and leadframe. The component is otherwise considered Pb-Free (RoHS compatible) as defined above.

**Green (RoHS & no Sb/Br):** TI defines "Green" to mean Pb-Free (RoHS compatible), and free of Bromine (Br) and Antimony (Sb) based flame retardants (Br or Sb do not exceed 0.1% by weight in homogeneous material)

<sup>(3)</sup> MSL, Peak Temp. -- The Moisture Sensitivity Level rating according to the JEDEC industry standard classifications, and peak solder temperature.

<sup>(4)</sup> Multiple Top-Side Markings will be inside parentheses. Only one Top-Side Marking contained in parentheses and separated by a "~" will appear on a device. If a line is indented then it is a continuation of the previous line and the two combined represent the entire Top-Side Marking for that device.

**Important Information and Disclaimer:** The information provided on this page represents TI's knowledge and belief as of the date that it is provided. TI bases its knowledge and belief on information provided by third parties, and makes no representation or warranty as to the accuracy of such information. Efforts are underway to better integrate information from third parties. TI has taken and continues to take reasonable steps to provide representative and accurate information but may not have conducted destructive testing or chemical analysis on incoming materials and chemicals. TI and TI suppliers consider certain information to be proprietary, and thus CAS numbers and other limited information may not be available for release.

In no event shall TI's liability arising out of such information exceed the total purchase price of the TI part(s) at issue in this document sold by TI to Customer on an annual basis.

#### **OTHER QUALIFIED VERSIONS OF UC1524, UC3524 :**

● Catalog: [UC3524](#)

● Military: [UC1524](#)

NOTE: Qualified Version Definitions:

● Catalog - TI's standard catalog product

● Military - QML certified for Military and Defense Applications

**TAPE AND REEL INFORMATION**

**REEL DIMENSIONS**



**TAPE DIMENSIONS**



|    |   |
|----|---|
| A0 | Dimension designed to accommodate the component width     |
| B0 | Dimension designed to accommodate the component length    |
| K0 | Dimension designed to accommodate the component thickness |
| W  | Overall width of the carrier tape                         |
| P1 | Pitch between successive cavity centers                   |

**TAPE AND REEL INFORMATION**

\*All dimensions are nominal

| Device     | Package Type | Package Drawing | Pins | SPQ  | Reel Diameter (mm) | Reel Width W1 (mm) | A0 (mm) | B0 (mm) | K0 (mm) | P1 (mm) | W (mm) | Pin1 Quadrant |
|------------|--------------|-----------------|------|------|--------------------|--------------------|---------|---------|---------|---------|--------|---------------|
| UC3524DWTR | SOIC         | DW              | 16   | 2000 | 330.0              | 16.4               | 10.75   | 10.7    | 2.7     | 12.0    | 16.0   | Q1            |

**TAPE AND REEL BOX DIMENSIONS**

\*All dimensions are nominal

| Device     | Package Type | Package Drawing | Pins | SPQ  | Length (mm) | Width (mm) | Height (mm) |
|------------|--------------|-----------------|------|------|-------------|------------|-------------|
| UC3524DWTR | SOIC         | DW              | 16   | 2000 | 367.0       | 367.0      | 38.0        |

J (R-GDIP-T\*\*)

14 LEADS SHOWN

CERAMIC DUAL IN-LINE PACKAGE



| DIM \ PINS ** | 14                     | 16                     | 18                     | 20                     |
|---------------|------------------------|------------------------|------------------------|------------------------|
| A             | 0.300<br>(7,62)<br>BSC | 0.300<br>(7,62)<br>BSC | 0.300<br>(7,62)<br>BSC | 0.300<br>(7,62)<br>BSC |
| B MAX         | 0.785<br>(19,94)       | .840<br>(21,34)        | 0.960<br>(24,38)       | 1.060<br>(26,92)       |
| B MIN         | —                      | —                      | —                      | —                      |
| C MAX         | 0.300<br>(7,62)        | 0.300<br>(7,62)        | 0.310<br>(7,87)        | 0.300<br>(7,62)        |
| C MIN         | 0.245<br>(6,22)        | 0.245<br>(6,22)        | 0.220<br>(5,59)        | 0.245<br>(6,22)        |



4040083/F 03/03

- NOTES:
- All linear dimensions are in inches (millimeters).
  - This drawing is subject to change without notice.
  - This package is hermetically sealed with a ceramic lid using glass frit.
  - Index point is provided on cap for terminal identification only on press ceramic glass frit seal only.
  - Falls within MIL STD 1835 GDIP1-T14, GDIP1-T16, GDIP1-T18 and GDIP1-T20.

N (R-PDIP-T\*\*)

PLASTIC DUAL-IN-LINE PACKAGE

16 PINS SHOWN



4040049/E 12/2002

- NOTES:
- A. All linear dimensions are in inches (millimeters).
  - B. This drawing is subject to change without notice.
  - $\triangle C$  Falls within JEDEC MS-001, except 18 and 20 pin minimum body length (Dim A).
  - $\triangle D$  The 20 pin end lead shoulder width is a vendor option, either half or full width.

D (R-PDSO-G16)

PLASTIC SMALL OUTLINE



4040047-6/M 06/11

- NOTES:
- A. All linear dimensions are in inches (millimeters).
  - B. This drawing is subject to change without notice.
  -  C. Body length does not include mold flash, protrusions, or gate burrs. Mold flash, protrusions, or gate burrs shall not exceed 0.006 (0,15) each side.
  -  D. Body width does not include interlead flash. Interlead flash shall not exceed 0.017 (0,43) each side.
  - E. Reference JEDEC MS-012 variation AC.

D (R-PDSO-G16)

PLASTIC SMALL OUTLINE



- NOTES:
- All linear dimensions are in millimeters.
  - This drawing is subject to change without notice.
  - Publication IPC-7351 is recommended for alternate designs.
  - Laser cutting apertures with trapezoidal walls and also rounding corners will offer better paste release. Customers should contact their board assembly site for stencil design recommendations. Refer to IPC-7525 for other stencil recommendations.
  - Customers should contact their board fabrication site for solder mask tolerances between and around signal pads.

DW (R-PDSO-G16)

PLASTIC SMALL OUTLINE



- NOTES:
- A. All linear dimensions are in inches (millimeters). Dimensioning and tolerancing per ASME Y14.5M-1994.
  - B. This drawing is subject to change without notice.
  - C. Body dimensions do not include mold flash or protrusion not to exceed 0.006 (0,15).
  - D. Falls within JEDEC MS-013 variation AA.



DW (R-PDSO-G16)

PLASTIC SMALL OUTLINE



4209202-2/E 07/11

- NOTES:
- A. All linear dimensions are in millimeters.
  - B. This drawing is subject to change without notice.
  - C. Refer to IPC7351 for alternate board design.
  - D. Laser cutting apertures with trapezoidal walls and also rounding corners will offer better paste release. Customers should contact their board assembly site for stencil design recommendations. Refer to IPC-7525
  - E. Customers should contact their board fabrication site for solder mask tolerances between and around signal pads.

## IMPORTANT NOTICE

Texas Instruments Incorporated and its subsidiaries (TI) reserve the right to make corrections, enhancements, improvements and other changes to its semiconductor products and services per JESD46, latest issue, and to discontinue any product or service per JESD48, latest issue. Buyers should obtain the latest relevant information before placing orders and should verify that such information is current and complete. All semiconductor products (also referred to herein as "components") are sold subject to TI's terms and conditions of sale supplied at the time of order acknowledgment.

TI warrants performance of its components to the specifications applicable at the time of sale, in accordance with the warranty in TI's terms and conditions of sale of semiconductor products. Testing and other quality control techniques are used to the extent TI deems necessary to support this warranty. Except where mandated by applicable law, testing of all parameters of each component is not necessarily performed.

TI assumes no liability for applications assistance or the design of Buyers' products. Buyers are responsible for their products and applications using TI components. To minimize the risks associated with Buyers' products and applications, Buyers should provide adequate design and operating safeguards.

TI does not warrant or represent that any license, either express or implied, is granted under any patent right, copyright, mask work right, or other intellectual property right relating to any combination, machine, or process in which TI components or services are used. Information published by TI regarding third-party products or services does not constitute a license to use such products or services or a warranty or endorsement thereof. Use of such information may require a license from a third party under the patents or other intellectual property of the third party, or a license from TI under the patents or other intellectual property of TI.

Reproduction of significant portions of TI information in TI data books or data sheets is permissible only if reproduction is without alteration and is accompanied by all associated warranties, conditions, limitations, and notices. TI is not responsible or liable for such altered documentation. Information of third parties may be subject to additional restrictions.

Resale of TI components or services with statements different from or beyond the parameters stated by TI for that component or service voids all express and any implied warranties for the associated TI component or service and is an unfair and deceptive business practice. TI is not responsible or liable for any such statements.

Buyer acknowledges and agrees that it is solely responsible for compliance with all legal, regulatory and safety-related requirements concerning its products, and any use of TI components in its applications, notwithstanding any applications-related information or support that may be provided by TI. Buyer represents and agrees that it has all the necessary expertise to create and implement safeguards which anticipate dangerous consequences of failures, monitor failures and their consequences, lessen the likelihood of failures that might cause harm and take appropriate remedial actions. Buyer will fully indemnify TI and its representatives against any damages arising out of the use of any TI components in safety-critical applications.

In some cases, TI components may be promoted specifically to facilitate safety-related applications. With such components, TI's goal is to help enable customers to design and create their own end-product solutions that meet applicable functional safety standards and requirements. Nonetheless, such components are subject to these terms.

No TI components are authorized for use in FDA Class III (or similar life-critical medical equipment) unless authorized officers of the parties have executed a special agreement specifically governing such use.

Only those TI components which TI has specifically designated as military grade or "enhanced plastic" are designed and intended for use in military/aerospace applications or environments. Buyer acknowledges and agrees that any military or aerospace use of TI components which have **not** been so designated is solely at the Buyer's risk, and that Buyer is solely responsible for compliance with all legal and regulatory requirements in connection with such use.

TI has specifically designated certain components as meeting ISO/TS16949 requirements, mainly for automotive use. In any case of use of non-designated products, TI will not be responsible for any failure to meet ISO/TS16949.

### Products

|                              |  |
|------------------------------|--|
| Audio                        | <a href="http://www.ti.com/audio">www.ti.com/audio</a>                               |
| Amplifiers                   | <a href="http://amplifier.ti.com">amplifier.ti.com</a>                               |
| Data Converters              | <a href="http://dataconverter.ti.com">dataconverter.ti.com</a>                       |
| DLP® Products                | <a href="http://www.dlp.com">www.dlp.com</a>   |
| DSP                          | <a href="http://dsp.ti.com">dsp.ti.com</a>   |
| Clocks and Timers            | <a href="http://www.ti.com/clocks">www.ti.com/clocks</a>                             |
| Interface                    | <a href="http://interface.ti.com">interface.ti.com</a>                               |
| Logic                        | <a href="http://logic.ti.com">logic.ti.com</a>                                       |
| Power Mgmt                   | <a href="http://power.ti.com">power.ti.com</a>                                       |
| Microcontrollers             | <a href="http://microcontroller.ti.com">microcontroller.ti.com</a>                   |
| RFID                         | <a href="http://www.ti-rfid.com">www.ti-rfid.com</a>                                 |
| OMAP Applications Processors | <a href="http://www.ti.com/omap">www.ti.com/omap</a>                                 |
| Wireless Connectivity        | <a href="http://www.ti.com/wirelessconnectivity">www.ti.com/wirelessconnectivity</a> |

### Applications

|                               |  |
|-------------------------------|--|
| Automotive and Transportation | <a href="http://www.ti.com/automotive">www.ti.com/automotive</a>                         |
| Communications and Telecom    | <a href="http://www.ti.com/communications">www.ti.com/communications</a>                 |
| Computers and Peripherals     | <a href="http://www.ti.com/computers">www.ti.com/computers</a>                           |
| Consumer Electronics          | <a href="http://www.ti.com/consumer-apps">www.ti.com/consumer-apps</a>                   |
| Energy and Lighting           | <a href="http://www.ti.com/energy">www.ti.com/energy</a>                                 |
| Industrial                    | <a href="http://www.ti.com/industrial">www.ti.com/industrial</a>                         |
| Medical                       | <a href="http://www.ti.com/medical">www.ti.com/medical</a>                               |
| Security                      | <a href="http://www.ti.com/security">www.ti.com/security</a>                             |
| Space, Avionics and Defense   | <a href="http://www.ti.com/space-avionics-defense">www.ti.com/space-avionics-defense</a> |
| Video and Imaging             | <a href="http://www.ti.com/video">www.ti.com/video</a>                                   |

### TI E2E Community

[e2e.ti.com](http://e2e.ti.com)