

# LOW PIN COUNT SYNCHRONOUS BUCK CONTROLLER

Check for Samples: [TPS40190](#)

## FEATURES

- Input Operating Voltage Range: 4.5 V to 15 V
- Reference 0.591 V  $\pm$ 1%
- Voltage Mode Control
- Internal 5-V Regulator For Internal Housekeeping, Driver Power and Light External Loads
- Selectable Short-Circuit Protection Thresholds
- Pre-Bias Output Safe
- Fixed Switching Frequency of 300 kHz
- Internal Soft-Start
- Small 3 mm  $\times$  3 mm, 10-Pin SON Package
- Bootstrapped Drivers for N-Channel MOSFET
- Adaptive Anti-Cross Conduction
- Internal Bootstrap Diode
- 1.2-A Drivers for Decreased Switching Loss

## APPLICATIONS

- Cable modem CPE
- Digital Set Top Box
- Graphics/Audio Cards
- Entry-level and Mid-Range Servers

## DESCRIPTION

The TPS40190 is a cost-optimized synchronous buck controller that operates from 4.5 V to 15 V nominally, and implements a fixed frequency voltage mode power supply. The controller uses an adaptive anti-cross conduction scheme to prevent both the high-side and the rectifier MOSFET to be turned on at the same time, preventing shoot through current in the two MOSFETs.

The controller also provides a short circuit protection threshold that is user selectable between one of three values. The protection level is set with a single external resistor connected from COMP to GND. During start-up, the impedance connected to COMP is sensed, and the information is decoded to select one of the three thresholds. When the controller senses an output short circuit, both MOSFETs are turned off and a timeout period is observed before attempting to restart. This provides limited power dissipation in the event of a sustained fault.

The TPS40190 provides strong drivers to minimize switching losses in the power stage, reducing heat build up in the MOSFETs and allowing larger MOSFETs to be used without undue switching time penalty.

## SIMPLIFIED APPLICATION DIAGRAM

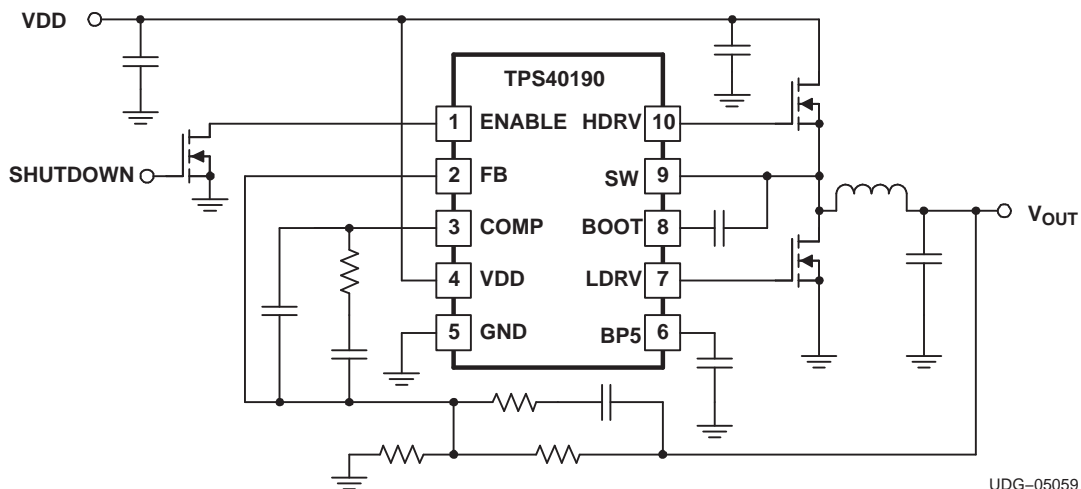

UDG-05059



Please be aware that an important notice concerning availability, standard warranty, and use in critical applications of Texas Instruments semiconductor products and disclaimers thereto appears at the end of this data sheet.



These devices have limited built-in ESD protection. The leads should be shorted together or the device placed in conductive foam during storage or handling to prevent electrostatic damage to the MOS gates.

**ORDERING INFORMATION**

T <sub>A</sub>	PACKAGE	PART NUMBER <sup>(1)</sup>
-40°C to 85°C	Plastic DRC (SON)	TPS40190DRCR
		TPS40190DRCT

(1) The TPS40190 is available taped and reeled only. Use large reel device type R to order quantities of 3000 units per reel. Use small reel device type T to order quantities of 250 per reel.

**ABSOLUTE MAXIMUM RATINGS**

over operating free-air temperature range unless otherwise noted<sup>(1)</sup>

		TPS40190	UNIT
Input voltage range	VDD	-0.3 to 16.5	V
	SW	-5 to 22	
	BOOT-SW, HDRV-SW (differential from BOOT or HDRV to SW)	-0.3 to 6	
	COMP	-0.3 to 3	
	FB, BP5, LDRV, ENABLE	-0.3 to 6	
T <sub>J</sub>	Operating junction temperature range	-40 to 125	°C
T <sub>stg</sub>	Storage temperature	-55 to 150	

(1) Stresses beyond those listed under "absolute maximum ratings" may cause permanent damage to the device. These are stress ratings only, and functional operation of the device at these or any other conditions beyond those indicated under "recommended operating conditions" is not implied. Exposure to absolute-maximum-rated conditions for extended periods may affect device reliability.

**DISSIPATION RATINGS**

PACKAGE	R <sub>θJA</sub> High-K Board <sup>(1)</sup> (°C/W)	R <sub>θJC</sub> <sup>(2)</sup> (°C/W)
DRC	47.9	14.1

- (1) The JEDEC High-K (2s2p) board design used to derive this data was a 3-inch x 3-inch (7.5-cm x 7.5-cm), multilayer board with one-ounce internal power and ground planes and two-ounce copper traces on top and bottom of the board.
- (2) The junction-to-case impedance is measured from the die to the thermal pad on the device package.

**RECOMMENDED OPERATING CONDITIONS**

		MIN	NOM	MAX	UNIT
V <sub>DD</sub>	Input voltage	4.5		15	V
T <sub>A</sub>	Operating free-air temperature	-40		85	°C

## ELECTRICAL CHARACTERISTICS

 $T_A = -40^{\circ}\text{C}$  to  $85^{\circ}\text{C}$ ,  $V_{\text{VDD}} = 12 V_{\text{dc}}$ ,  $T_A = T_J$ , all parameters at zero power dissipation (unless otherwise noted)

PARAMETER		TEST CONDITIONS	MIN	TYP	MAX	UNIT
<b>REFERENCE</b>						
$V_{\text{FB}}$	Feedback voltage range	$0^{\circ}\text{C} \leq T_J \leq 85^{\circ}\text{C}$	585	591	597	mV
		$-40^{\circ}\text{C} \leq T_J \leq 85^{\circ}\text{C}$	582	591	597	
<b>INPUT SUPPLY</b>						
$V_{\text{VDD}}$	Input voltage range		4.5		15.0	V
$I_{\text{VDD}}$	Operating current	$V_{\text{ENABLE}} = 2.5 \text{ V}$ , Outputs switching			2.5	mA
		$V_{\text{ENABLE}} = 0.6 \text{ V}$			20	$\mu\text{A}$
<b>ON BOARD REGULATOR</b>						
$V_{5\text{VBP}}$	Output voltage	$V_{\text{VDD}} > 6 \text{ V}$ , $I_{5\text{VBP}} \leq 10 \text{ mA}$	5.1	5.3	5.5	V
$V_{\text{DO}}$	Regulator dropout voltage	$V_{\text{VDD}} - V_{\text{BP5}}$ , $V_{\text{VDD}} = 5 \text{ V}$ , $I_{\text{BP5}} \leq 25 \text{ mA}$		270	400	mV
$I_{\text{SC}}$	Regulator current limit threshold		40			mA
$I_{\text{BP5}}$	Average current <sup>(1)</sup>				40	
<b>OSCILLATOR</b>						
$f_{\text{SW}}$	Switching frequency		240	300	360	kHz
$V_{\text{RMP}}$	Ramp amplitude <sup>(2)</sup>			0.75		V
$V_{\text{VALLEY}}$	Valley voltage <sup>(2)</sup>			0.5		
<b>PWM</b>						
$D_{\text{MAX}}$	Maximum duty cycle <sup>(2)</sup>		85%			
$t_{\text{ON(min)}}$	Minimum controlled pulse <sup>(2)</sup>				130	ns
$t_{\text{DEAD}}$	Output driver dead time	HDRV off to LDRV on		50		
		LDRV off to HDRV on		25		
<b>SOFT-START</b>						
$t_{\text{SS}}$	Soft-start time		3.0	4.7	7.0	ms
$t_{\text{SSDLY}}$	Soft-start delay time <sup>(3)</sup>			6		
$t_{\text{REG}}$	Time to regulation			10.5		
<b>ERROR AMPLIFIER</b>						
GBWP	Gain bandwidth product <sup>(2)</sup>		5			MHz
$A_{\text{OL}}$	DC gain <sup>(2)</sup>		60			dB
$I_{\text{IB}}$	Input bias current (current out of FB pin)		100		0	nA
$I_{\text{EAOP}}$	Output source current	$V_{\text{FB}} = 0 \text{ V}$	1			mA
$I_{\text{EAOM}}$	Output sink current	$V_{\text{FB}} = 2 \text{ V}$	1			
<b>SHORT CIRCUIT PROTECTION</b>						
$t_{\text{PSS(min)}}$	Minimum pulse during short circuit <sup>(2)</sup>				250	ns
$t_{\text{BLNK}}$	Blanking time <sup>(2)</sup>		100	140	180	
$t_{\text{OFF}}$	Off-time between restart attempts		25	95		ms
$V_{\text{ILIM}}$	Short circuit comparator threshold voltage	$R_{\text{COMP(GND)}} = \text{OPEN}$ , $T_J = 25^{\circ}\text{C}$	256	320	384	mV
		$R_{\text{COMP(GND)}} = 4 \text{ k}\Omega$ , $T_J = 25^{\circ}\text{C}$	128	160	192	
		$R_{\text{COMP(GND)}} = 12 \text{ k}\Omega$ , $T_J = 25^{\circ}\text{C}$	368	460	552	

(1) 40 mA is the current available for MOSFET gate drive, the device itself and any external loads. The sum of these must not exceed 40 mA.

(2) Specified by design. Not production tested.

(3) The delay time is the time delay from application of power to the device or from assertion of ENABLE until the output begins to rise.

**ELECTRICAL CHARACTERISTICS (continued)**

$T_A = -40^{\circ}\text{C}$  to  $85^{\circ}\text{C}$ ,  $V_{\text{VDD}} = 12 V_{\text{dc}}$ ,  $T_A = T_J$ , all parameters at zero power dissipation (unless otherwise noted)

PARAMETER		TEST CONDITIONS	MIN	TYP	MAX	UNIT
<b>OUTPUT DRIVERS</b>						
$R_{\text{HDHI}}$	High-side driver pull-up resistance	$V_{\text{BOOT}} - V_{\text{SW}} = 4.5 \text{ V}$ , $I_{\text{HDRV}} = -100 \text{ mA}$		3	6	$\Omega$
$R_{\text{HDLO}}$	High-side driver pull-down resistance	$V_{\text{BOOT}} - V_{\text{SW}} = 4.5 \text{ V}$ , $I_{\text{HDRV}} = 100 \text{ mA}$		1.5	3.0	
$R_{\text{LDHI}}$	Low-side driver pull-up resistance	$I_{\text{LDRV}} = -100 \text{ mA}$		2.5	5.0	
$R_{\text{LDLO}}$	Low-side driver pull-down resistance	$I_{\text{LDRV}} = 100 \text{ mA}$		0.80	1.50	
$t_{\text{HRISE}}$	High-side driver rise time <sup>(4)</sup>	$C_{\text{LOAD}} = 1 \text{ nF}$		15	35	ns
$t_{\text{HFALL}}$	High-side driver fall time <sup>(4)</sup>			10	25	
$t_{\text{LRISE}}$	Low-side driver rise time <sup>(4)</sup>			15	35	
$t_{\text{LFALL}}$	Low-side driver fall time <sup>(4)</sup>			10	25	
<b>UVLO</b>						
$V_{\text{UVLO}}$	Turn-on voltage		4.10	4.25	4.40	V
$\text{UVLO}_{\text{HYST}}$	Hysteresis		270	320	370	mV
<b>SHUTDOWN</b>						
$V_{\text{IH}}$	High-level input voltage, ENABLE				2.8	V
$V_{\text{IL}}$	Low-level input voltage, ENABLE		0.6			
<b>BOOT DIODE</b>						
$V_{\text{DFWD}}$	Bootstrap diode forward voltage	$I_{\text{BOOT}} = 5 \text{ mA}$	0.6	0.8	1.2	V

(4) Specified by design. Not production tested.

**DEVICE INFORMATION**

**TERMINAL FUNCTIONS**

TERMINAL		I/O	DESCRIPTION
NAME	NO.		
BOOT	8	I	Power supply for the flying high-side driver
BP5	6	O	Output bypass for the internal regulator. Connect 4.7- $\mu$ F capacitor from this pin to GND. Low power, low noise loads may be connected here if desired. The sum of the external load and the gate drive requirements must not exceed 40 mA. The regulator is turned off when the ENABLE pin is pulled low.
COMP	3	O	Output of the error amplifier. Connecting a resistance from COMP to GND sets the output short circuit detection threshold. See applications information for details.
ENABLE	1	I	Logic level input that starts or stops the controller from an external user command. A high level turns the controller on. This pin has a high-impedance internal pull-up integrated into the device. Because this pin is high impedance, a 10-nF capacitor to ground or an external pull-up resistor (100 k $\Omega$ ) to VDD is recommended to avoid noise coupling to this pin.
FB	2	I	Inverting input to the error amplifier
GND	5	-	Common connection for the controller
HDRV	10	O	Bootstrapped output for driving the gate of the high side N channel FET.
LDRV	7	O	Output to the rectifier FET gate
SW	9	I	Sense line for the adaptive anti cross conduction circuitry. Serves as common connection for the flying high side FET driver
VDD	4	I	Power input to the controller

**DRC PACKAGE  
(TOP VIEW)**

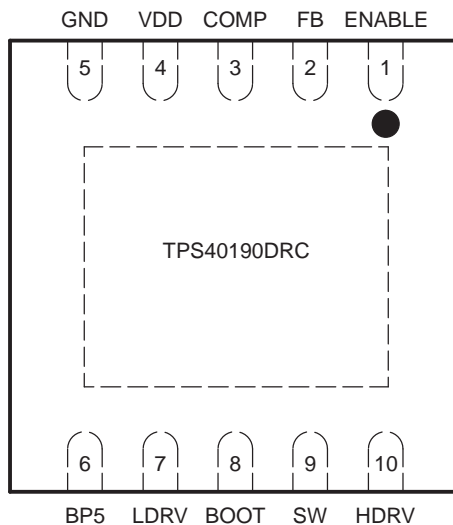

## APPLICATION INFORMATION

### Introduction

The TPS40190 is a cost optimized controller providing all the necessary features to construct a high-performance DC-DC converter while keeping costs to a minimum. Support for pre-biased outputs eliminates concerns about damaging sensitive loads during startup. Strong gate drivers for the high side and rectifier N-channel MOSFETs decrease switching losses for increased efficiency. Adaptive gate drive timing minimizes body diode conduction in the rectifier MOSFET, also increasing efficiency. Selectable short circuit protection thresholds and hiccup recovery from a short-circuit increase design flexibility and minimize power dissipation in the event of a prolonged output fault. A dedicated enable pin (ENABLE) allows the converter to be placed in a very low quiescent current shutdown mode.

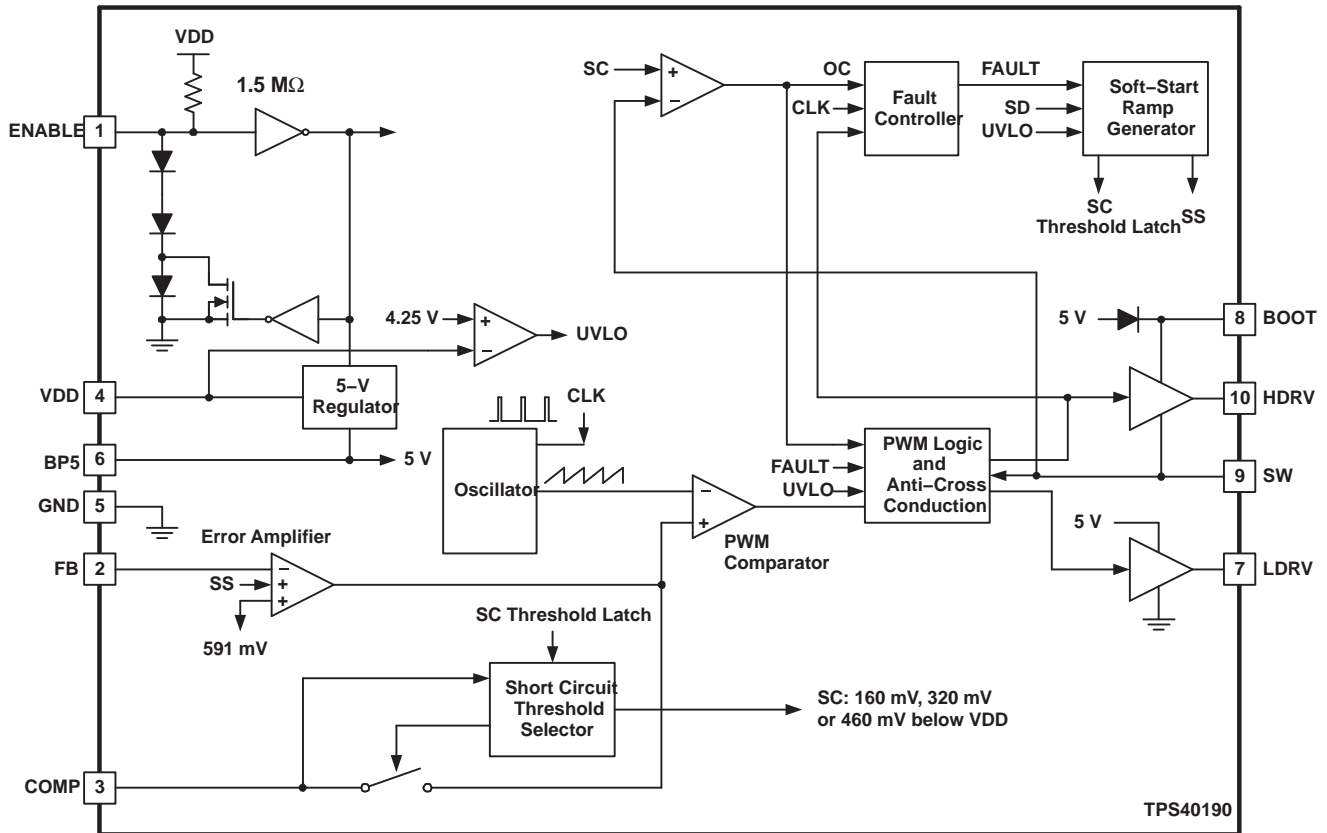

UDG-05060

Internally fixed switching frequency and soft-start time reduce external component count, simplifying design and layout, as well as reducing footprint and cost. The 3 mm x 3 mm package size also contributes to a reduced overall converter footprint.

### Internally Fixed Parameters

The TPS40190 has a fixed internal switching frequency of 300 kHz. Soft-start time is fixed at 4.7 ms typical and the UVLO level is set between 4.1 V and 4.4 V.

## Output Short Circuit Protection

The short circuit detection in the TPS40190 is done by sensing the voltage drop across the high side FET when it is on. If the voltage drop across this FET exceeds the selected threshold in any given switching cycle, a counter counts up one count and the FET is turned off early. If the voltage drop across that FET does not exceed this threshold, the counter is decremented for that cycle and the FET is allowed to remain on for the normal pulse width commanded by the internal pulse width modulator. If the counter fills up (a count of 7) a fault condition is declared and the drivers turn both FETs off. After a timeout of approximately 95 ms, the controller attempts to restart. If a short circuit is still present at the output, the current ramps quickly up to the short-circuit threshold and another fault condition is declared. The device then waits 95 ms to attempt to restart again.

Typical waveforms during a short circuit event are shown in [Figure 1](#) and [Figure 2](#).

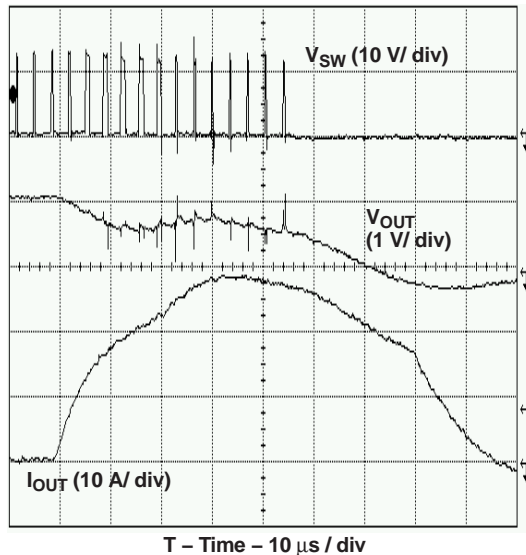

**Figure 1. Output Short Circuit Detected (Nominal Threshold 25 A)**

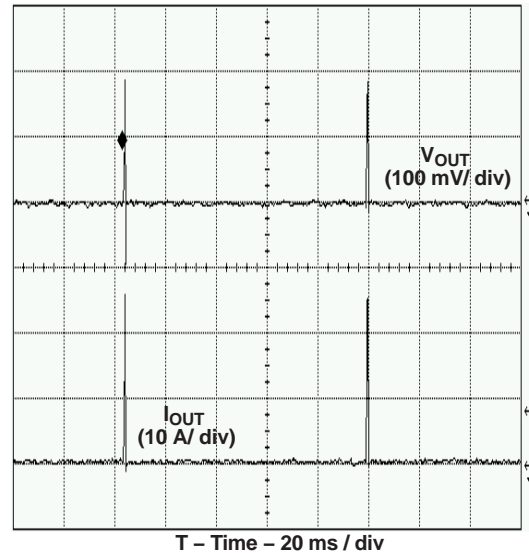

**Figure 2. Output Fault Hiccup Restart Timing**

The TPS40190 provides three selectable short circuit protection thresholds: 160 mV, 320 mV and 460 mV. The particular threshold is selected by connecting a resistor from COMP to GND. [Table 1](#) gives the short circuit thresholds for corresponding resistors from COMP to GND. Note that since the TPS40190 measures the resistance from COMP to GND during a 2-ms window, the compensation network from COMP to FB should have a time constant significantly less than 1 ms or there can be issues detecting the resistance and setting the correct short circuit threshold. This network should have no DC path from COMP to FB.

The short circuit detection threshold in the TPS40190 has some temperature compensation built in to help offset the high-side FET rise in resistance as its temperature rises. A typical FET has a resistance temperature coefficient of about 4500 ppm/°C. The temperature coefficient of the short circuit threshold is approximately 4200 ppm/°C. [Figure 3](#) shows how the short circuit threshold increases with temperature to help compensate for the FET resistance increase. The relative FET resistance change is based on an estimate of a linear 4500 ppm/°C temperature coefficient. The effectiveness of this compensation depends on how tight the thermal coupling between the TPS40190 and the high-side FET is. Better thermal coupling between the TPS40190 and the high-side FET gives better compensation effectiveness.

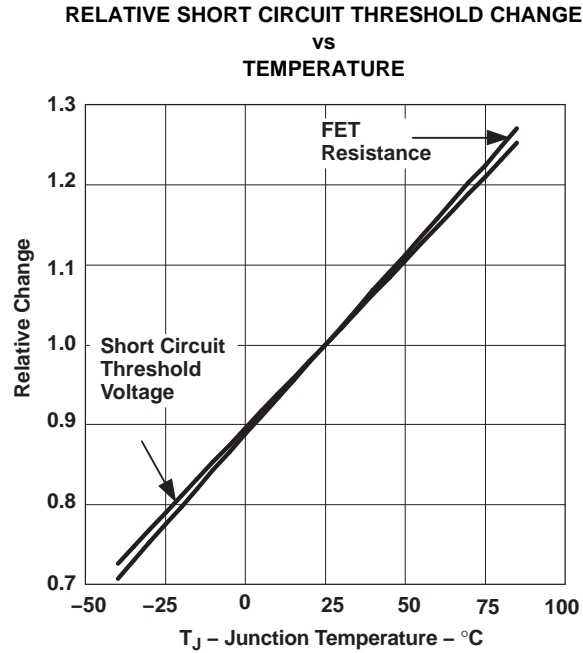

Figure 3.

Table 1. Short Circuit Threshold Voltage Selection

Short Circuit Protection Resistance R <sub>COMP</sub> (kΩ)	Nominal Current Limit Voltage V <sub>ILIM</sub> (mV)
10.8 to 13.2	460
OPEN	320
3.6 to 4.4	160

The range of short circuit current thresholds that can be expected is given by [Equation 1](#) and [Equation 2](#).

$$I_{SCP(max)} = \frac{V_{ILIM(max)}}{R_{DS(onMIN)}} \tag{1}$$

$$I_{SCP(min)} = \frac{V_{ILIM(min)}}{R_{DS(onMAX)}}$$

where

- I<sub>SCP</sub> is the short circuit current
  - V<sub>ILIM</sub> is the short circuit threshold
  - R<sub>DS(on)</sub> is the channel resistance of the high-side MOSFET
- (2)



## Enable Functionality

The TPS40190 has a dedicated ENABLE pin. This simplifies user level interface design since no multiplexed functions exist. Another benefit is a true low power shutdown mode of operation. In this state, the BP5 regulator is turned off. When the ENABLE pin is pulled to GND, the TPS40190 consumes a typical 20- $\mu$ A of current. A functionally equivalent circuit to the enable circuitry on the TPS40190 is shown in Figure 4.

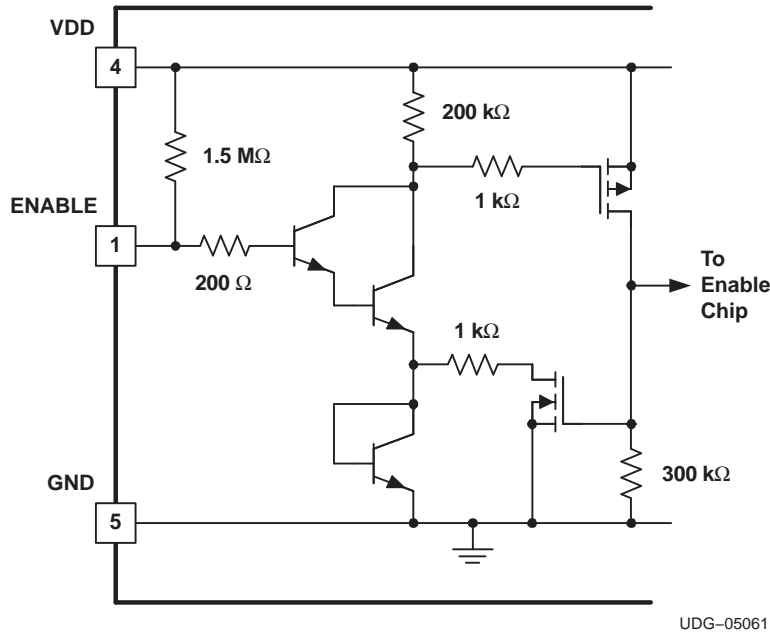

Figure 4. TPS40190 ENABLE Pin Internal Circuitry

If the ENABLE pin is left floating, the chip starts automatically. The pin must be pulled to less than 600 mV to ensure that the TPS40190 is in shutdown mode. Note that the ENABLE pin is relatively high impedance. In some situations, there could be enough noise nearby to cause the ENABLE pin to swing below the 600 mV threshold and give erroneous shutdown commands to the rest of the device. There are two solutions to this problem should it arise.

1. Place a capacitor from ENABLE to GND. A side effect of this is to delay the start of the converter while the capacitor charges past the enable threshold
2. Place a resistor from VDD to ENABLE. This causes more current to flow in the shutdown mode, but does not delay converter startup. If a resistor is used, the total current into the ENABLE pin should be limited to no more than 500  $\mu$ A.

The ENABLE pin is self-clamping. The clamp voltage can be as low as 1 V with a 1-k $\Omega$  ground impedance. Due to this self-clamping feature, the pull-up impedance on the ENABLE pin should be selected to limit the sink current to less than 500  $\mu$ A. Driving the ENABLE pin with a low-impedance source voltage can result in damage to the device. Because of the self-clamping feature, it requires care when connecting multiple ENABLE pins together. For enabling multiple TPS4019x devices (TPS40190, TPS40192, TPS40193, TPS40195, TPS40197), see the Application Report [SLVA509](#).

Typical waveforms for startup and shutdown using the ENABLE pin are shown in [Figure 5](#) and [Figure 6](#).

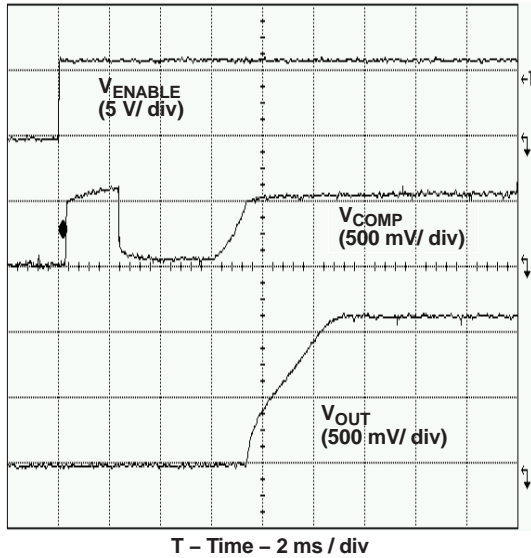

Figure 5. Startup Using ENABLE Pin

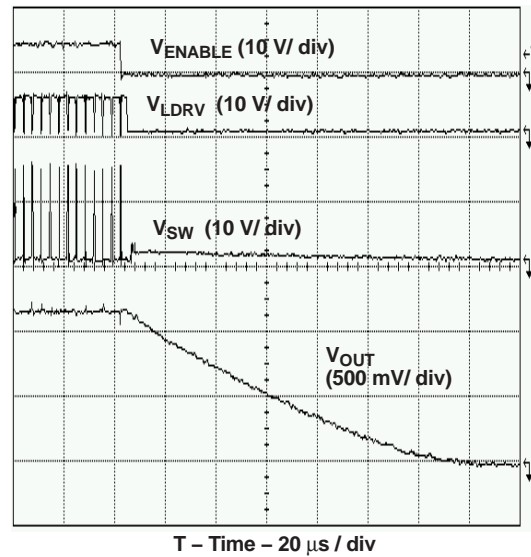

Figure 6. Shutdown Using ENABLE Pin

### 5-V Regulator

The TPS40190 has an on board 5-V regulator that allows the part to operate from a single voltage feed. No separate 5-V feed to the part is required. This regulator needs to have 4.7-μF of capacitance on the BP5 pin for stability. A ceramic capacitor is suggested for this purpose.

This regulator can also be used to supply power to nearby circuitry, eliminating the need for a separate LDO in some cases. If this pin is used for external loads, keep in mind that this is the power supply for the internals of the TPS40190. While efforts have been made to reduce sensitivity, any noise induced on this line has an adverse effect on the overall performance of the internal circuitry and shows up as increased pulse jitter, or skewed reference voltage. This regulator is turned off when the ENABLE pin is pulled low.

The amount of power available from this pin varies with the size of the power MOSFETs that the drivers must operate. Larger MOSFETs require more gate drive current and reduces the amount of power available on this pin for other tasks.

The total amount of current required by the gate drive and the external circuitry should not exceed 40 mA. The current required to drive the FET gates can be found from [Equation 3](#).

$$I_G = f_{SW} \times (Q_{G(high)} + Q_{G(low)})$$

Where

- $I_G$  is the required gate drive current
- $f_{SW}$  is the switching frequency (300 kHz)
- $Q_{G(high)}$  is the gate charge requirement for the high-side FET at 5 V  $V_{GS}$
- $Q_{G(low)}$  is the gate charge requirement for the low-side FET at 5 V  $V_{GS}$

(3)

### Startup Sequence and Timing

The TPS40190 startup sequence is as follows. After input power is applied, the 5-V onboard regulator comes up. Once this regulator comes up, the TPS40190 goes through a period where it samples the impedance at the COMP pin and decides the short circuit protection threshold voltage. This is accomplished by placing 400 mV on the COMP pin for approximately 2 ms. During this time, the current is measured and compared against internal thresholds to select the short circuit protection threshold. After this, the COMP pin is brought low for 4 ms. This ensures that the feedback loop is preconditioned at startup and no sudden output rise occurs at the output of the converter when the converter is allowed to start switching. After these initial 6 milliseconds, the internal soft-start circuitry is engaged and the converter is allowed to start. See [Figure 7](#).

## Pre-Bias Outputs

Some applications require that the converter not sink current during startup if a pre-existing voltage is higher than the output. Since synchronous buck converters inherently sink current some method of overcoming this characteristic must be employed. Applications that require this operation are typically power rails for a multi supply processor or ASIC. The method used in this controller, is to not allow the low side or rectifier FET to turn on until there the output voltage commanded by the start up ramp is higher than the pre-existing output voltage. This is detected by monitoring the internal pulse width modulator (PWM) for its first output pulse. Since this controller uses a closed loop startup, the first output pulse from the PWM does not occur until the output voltage is commanded to be higher than the pre-existing voltage. This effectively limits the controller to sourcing current only during the startup sequence.

If the pre-existing voltage is higher than the intended regulation point for the output of the converter, the converter starts and sinks current when the soft-start time has completed. A typical pre-biased startup is shown in Figure 8.

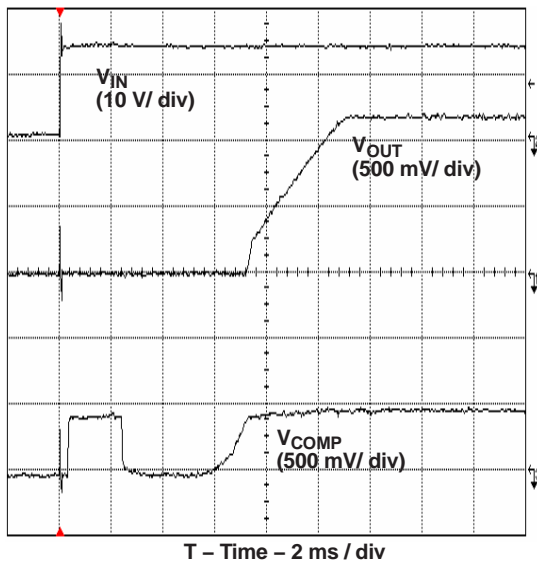

Figure 7. TPS40190 Startup Timing

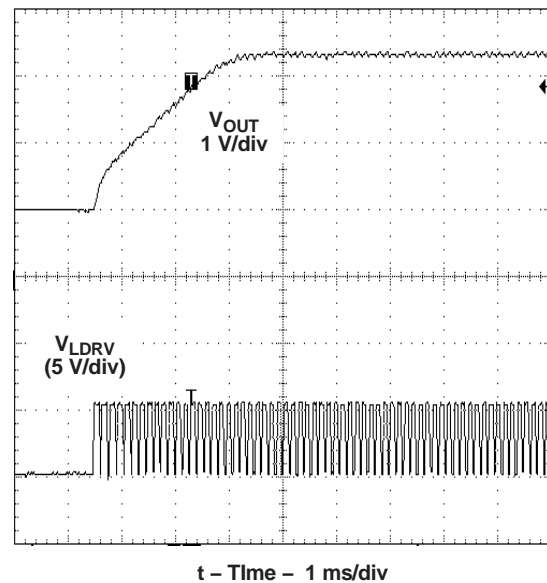
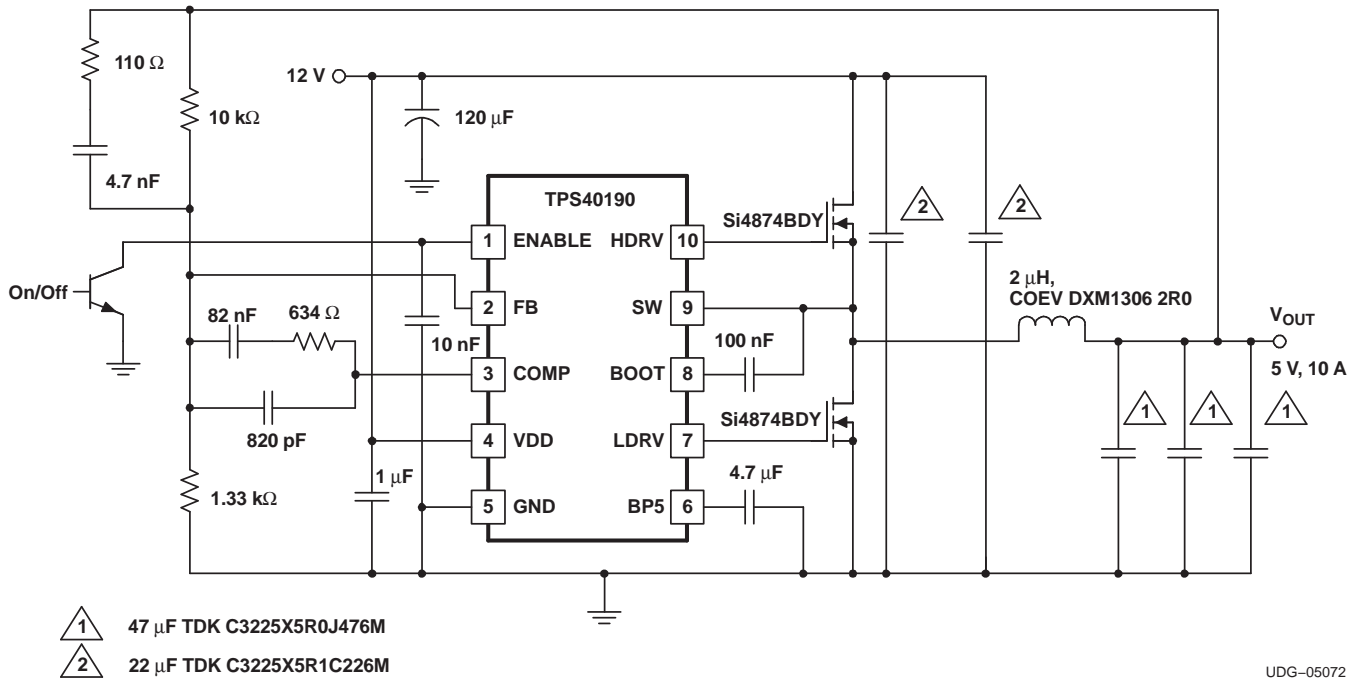

Figure 8. Prebiased Startup Timing

## Typical Applications

Some typical applications.



UDG-05072

Figure 9. 12-V to 5-V at 10 A

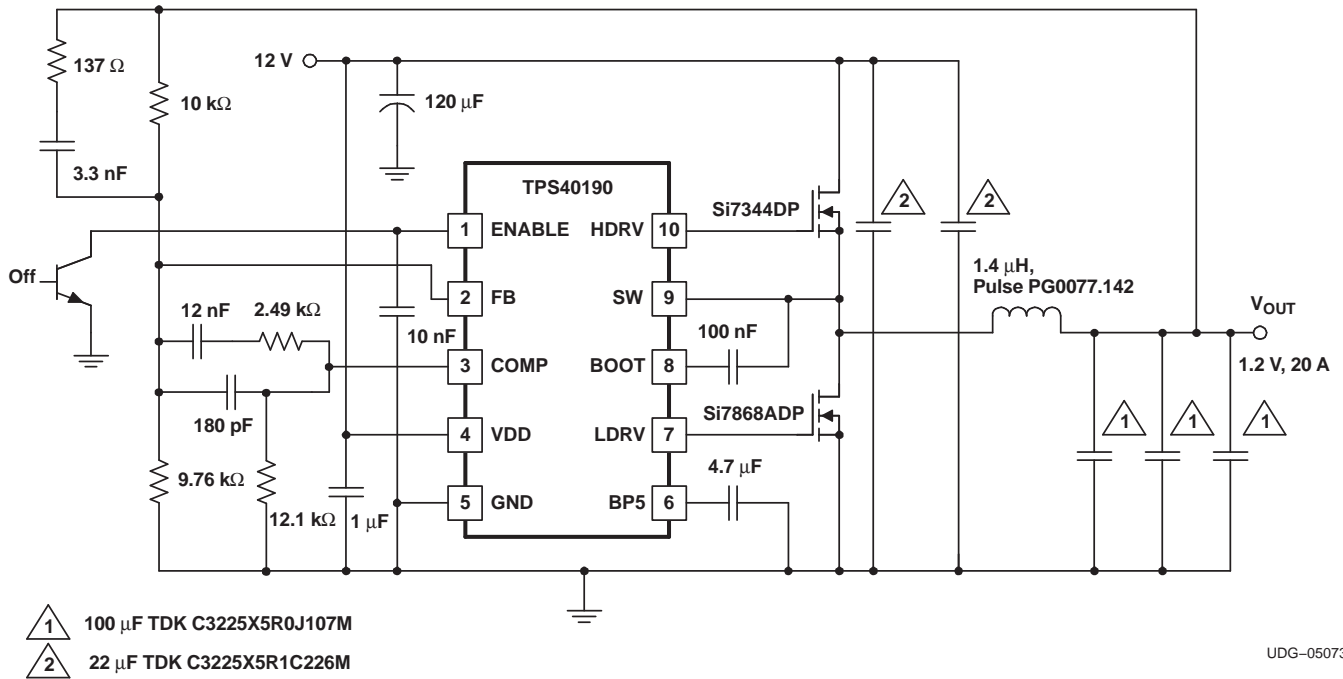

UDG-05073

Figure 10. 12-V to 1.2-V at 20 A

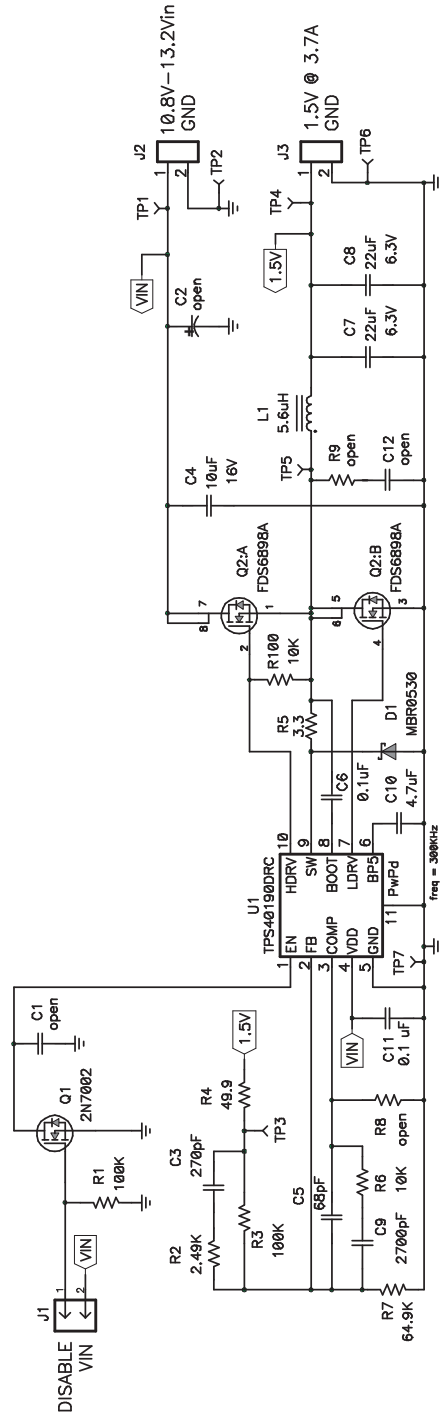

Figure 11. PMP1285, 12-V to 1.5-V, at 3.7 A

Typical Characteristics

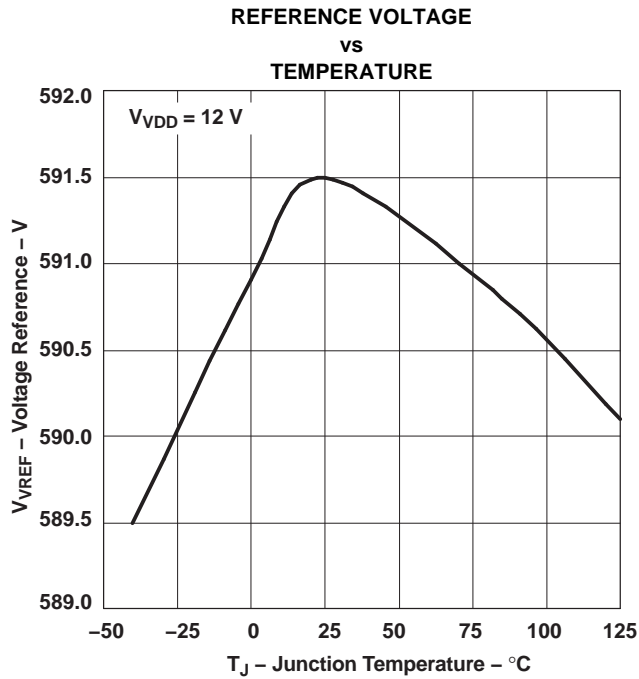

Figure 12.

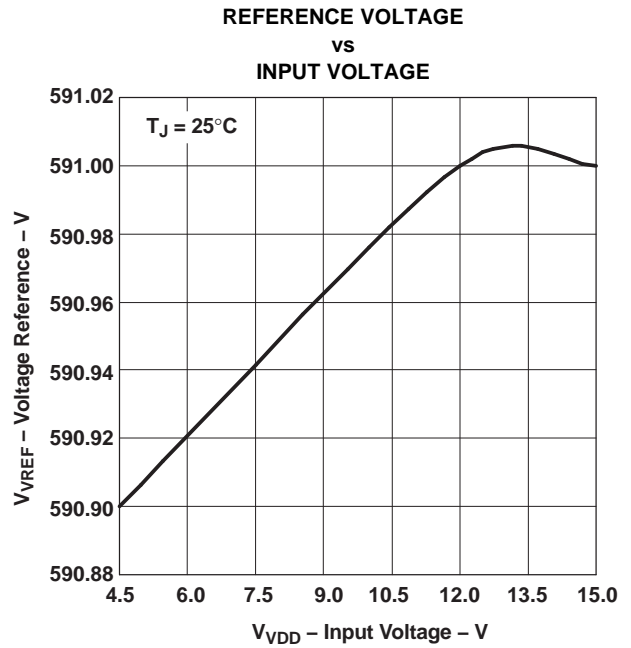

Figure 13.

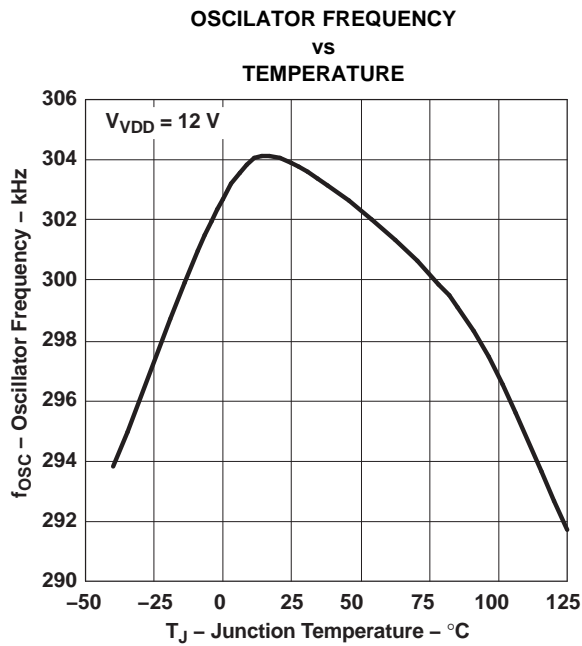

Figure 14.

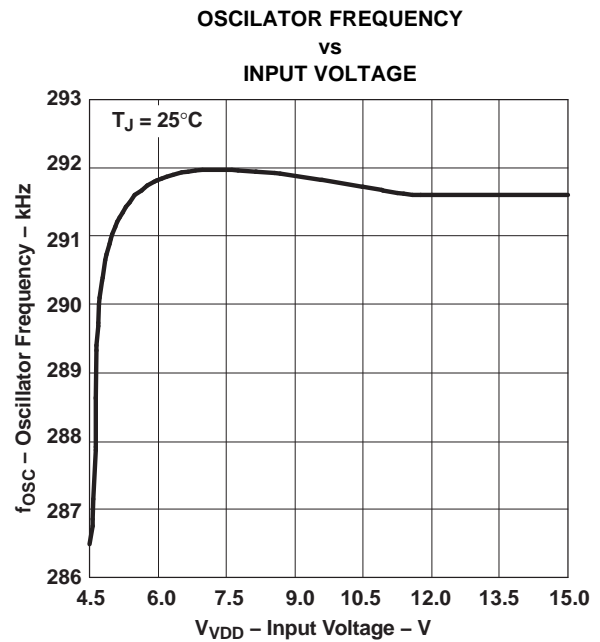

Figure 15.

Typical Characteristics (continued)

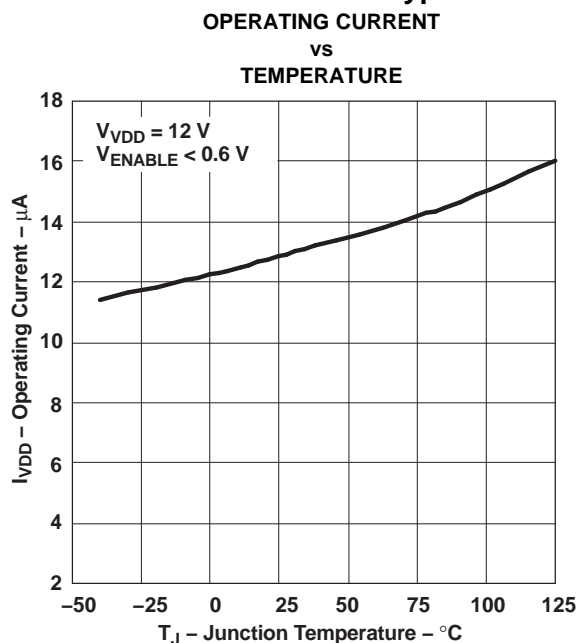

Figure 16.

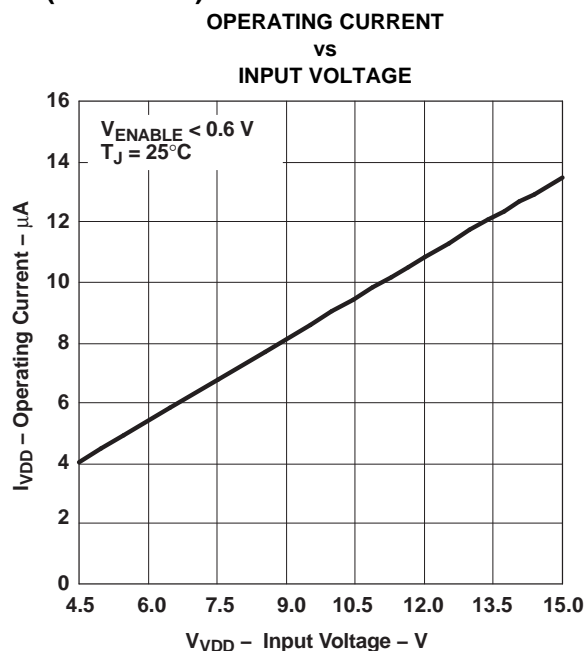

Figure 17.

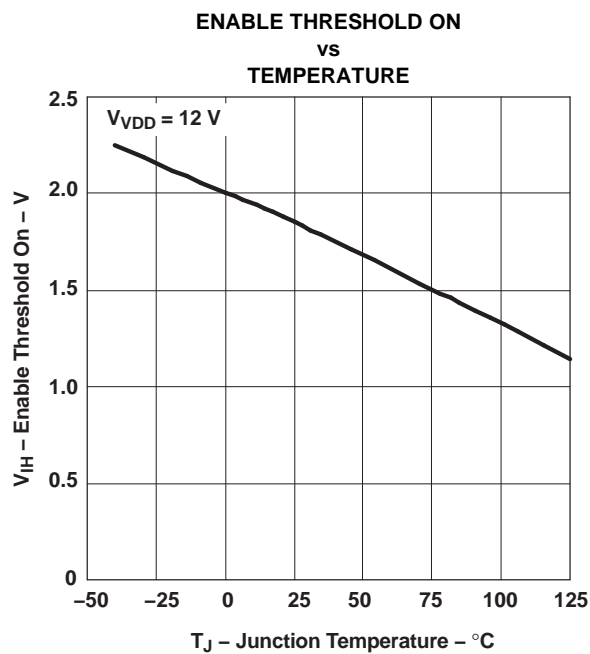

Figure 18.

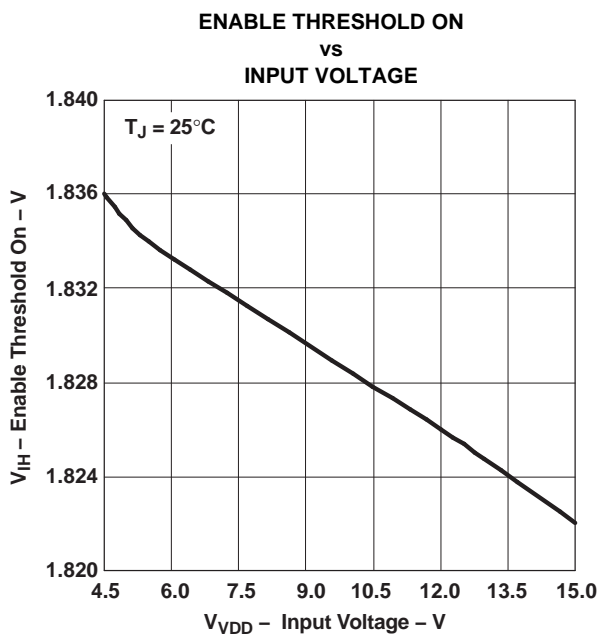

Figure 19.

Typical Characteristics (continued)

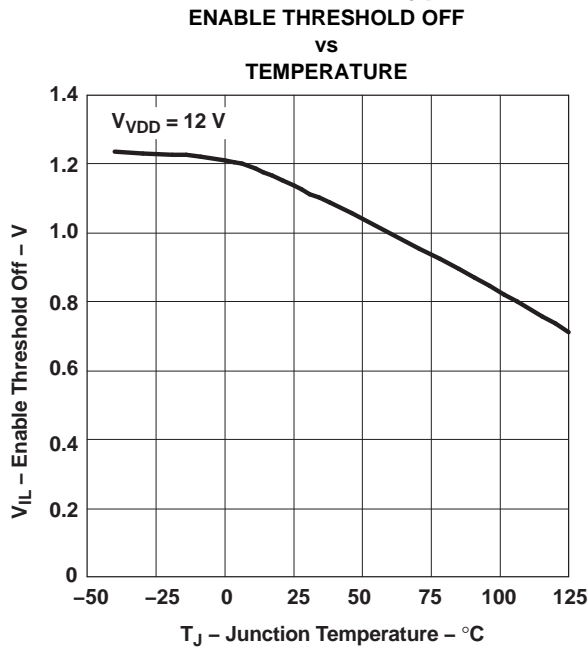

Figure 20.

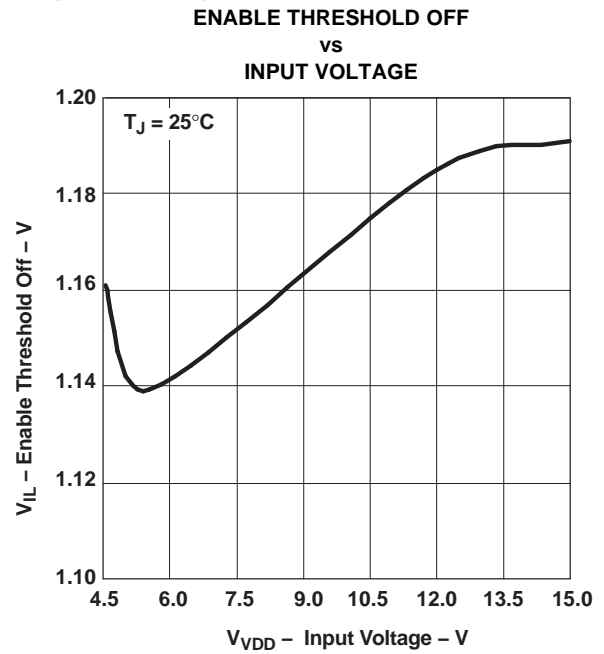

Figure 21.

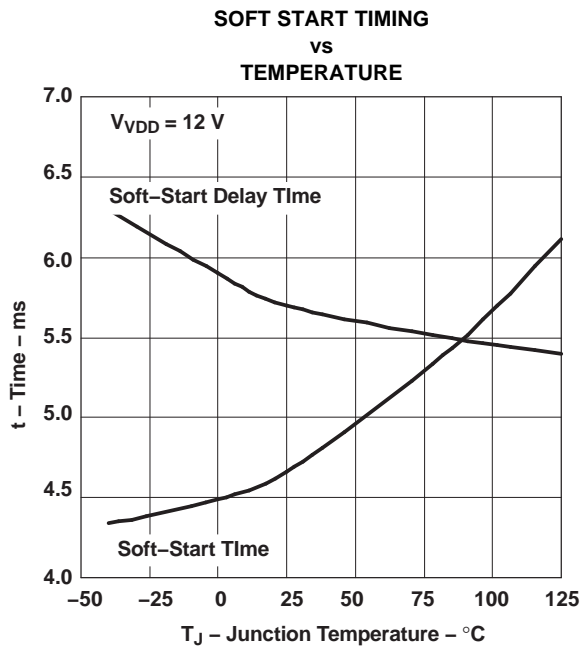

Figure 22.

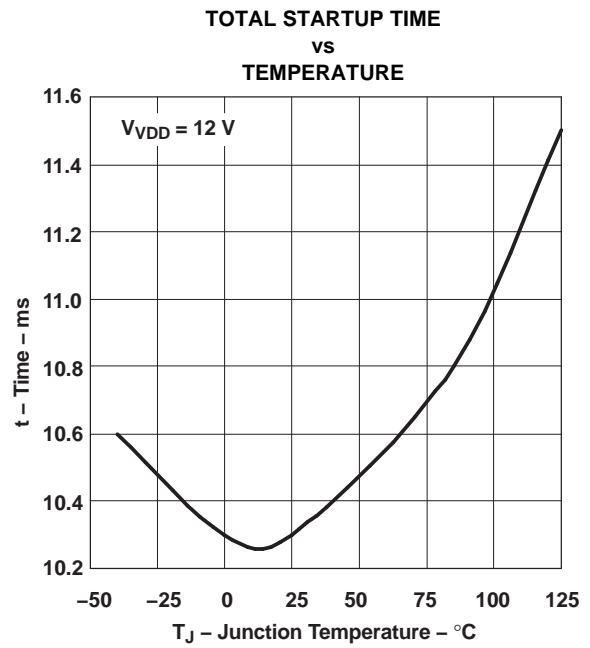
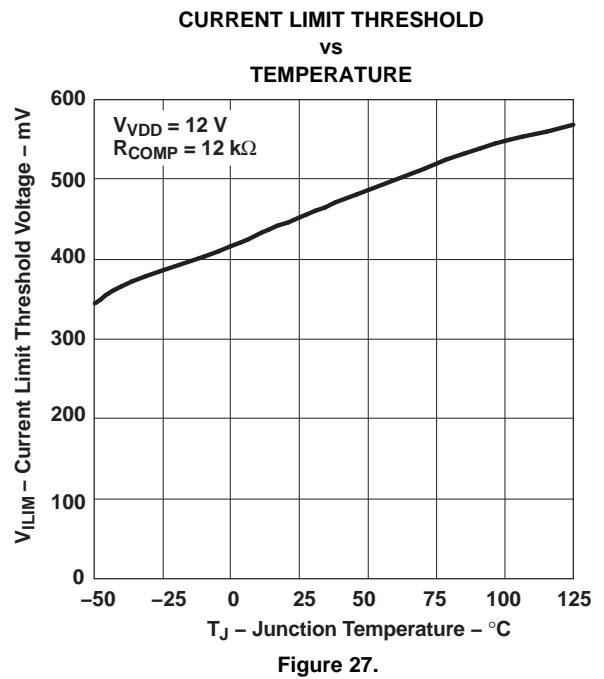
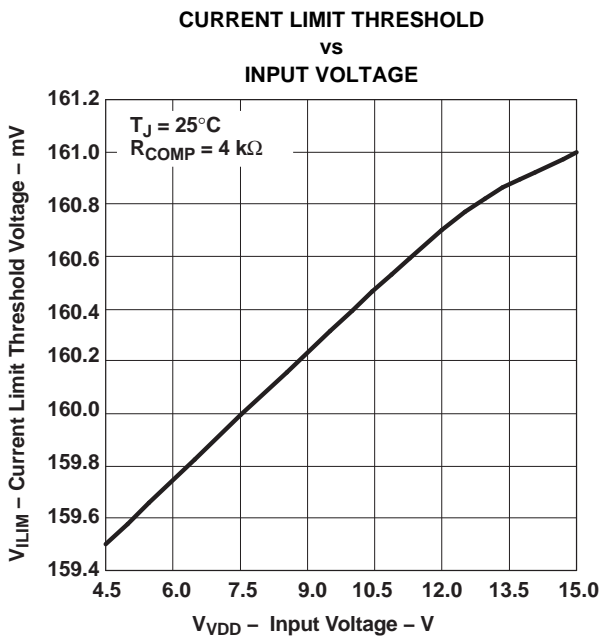
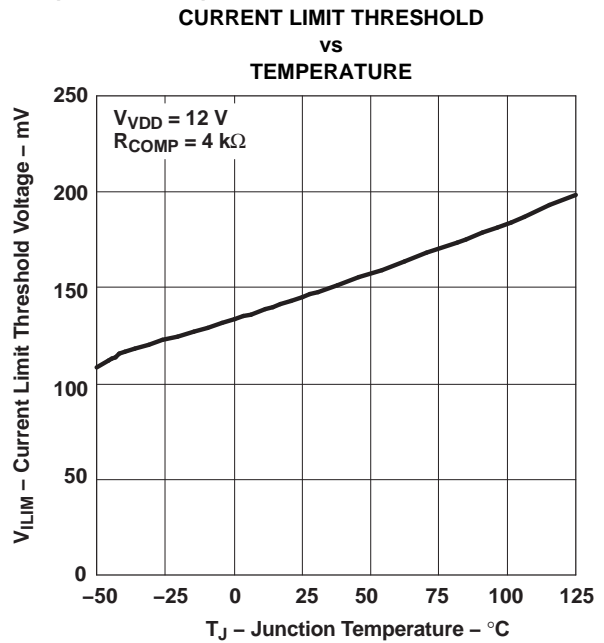
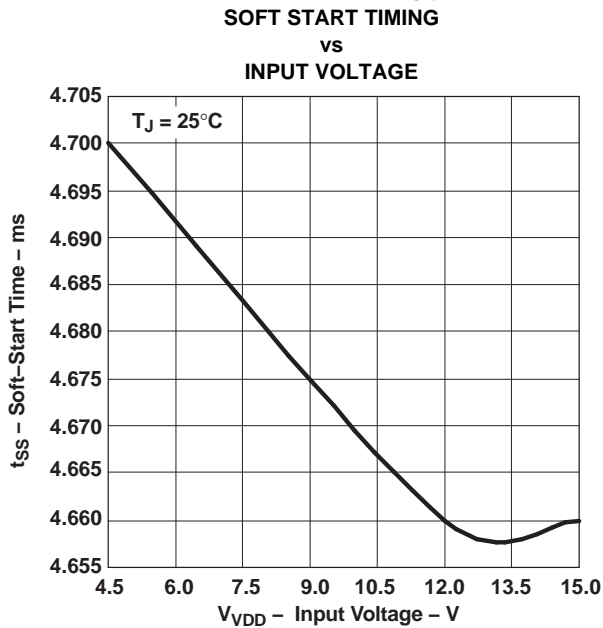

Figure 23.



Typical Characteristics (continued)



Typical Characteristics (continued)

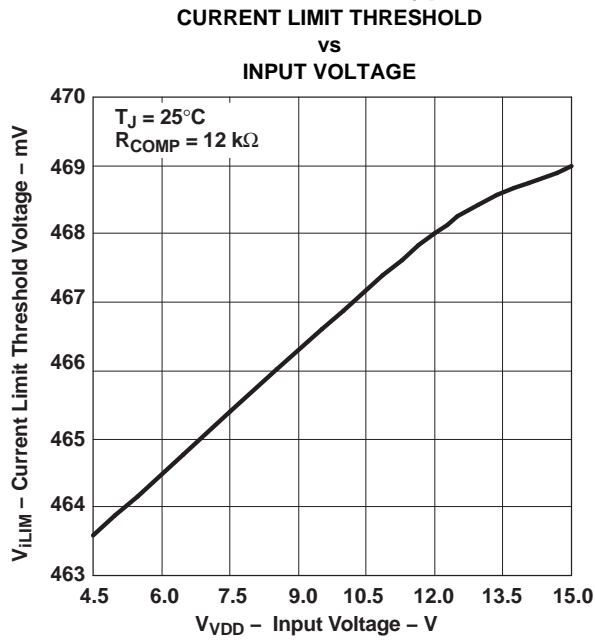

Figure 28.

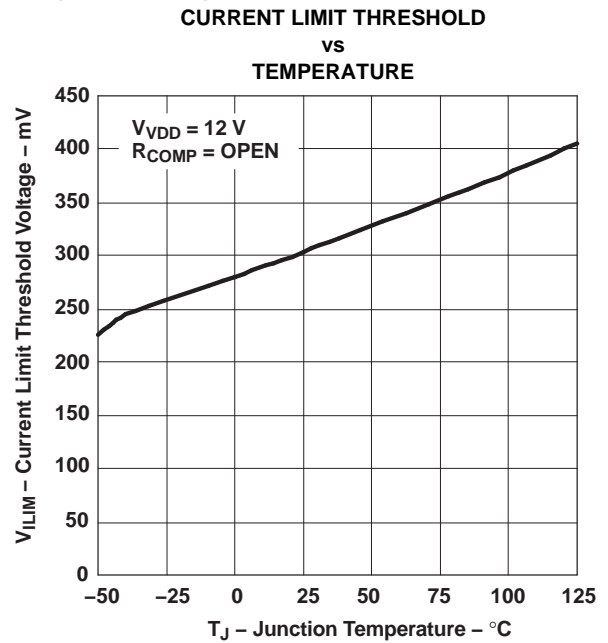

Figure 29.

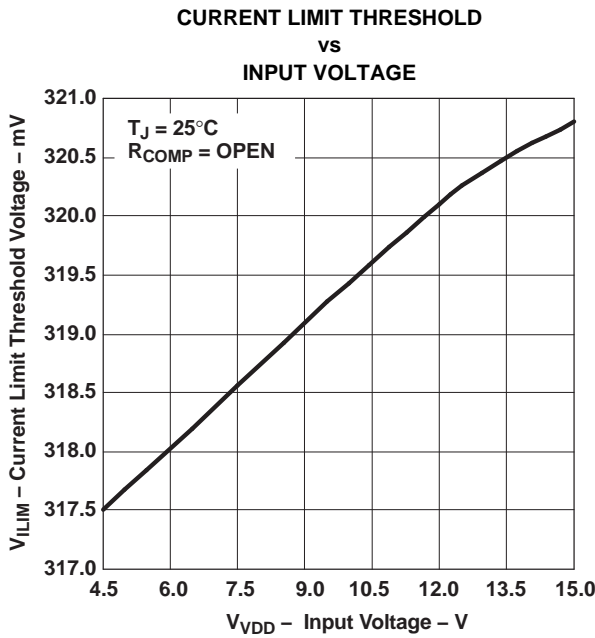

Figure 30.

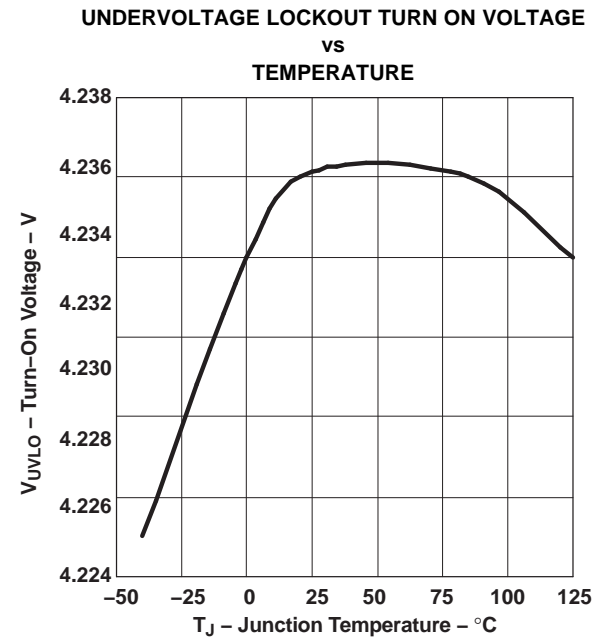

Figure 31.

---

**REVISION HISTORY**

<b>Changes from Revision B (August 2007) to Revision C</b>	<b>Page</b>
• Added a new paragraph to the end of the Enable Functionality section .....	<a href="#">9</a>

---

**PACKAGING INFORMATION**

Orderable Device	Status (1)	Package Type	Package Drawing	Pins	Package Qty	Eco Plan (2)	Lead/Ball Finish	MSL Peak Temp (3)	Op Temp (°C)	Top-Side Markings (4)	Samples
TPS40190DRCCR	ACTIVE	SON	DRC	10	3000	Green (RoHS & no Sb/Br)	CU NIPDAU	Level-2-260C-1 YEAR	-40 to 85	0190	<a href="#">Samples</a>
TPS40190DRCRG4	ACTIVE	SON	DRC	10	3000	Green (RoHS & no Sb/Br)	CU NIPDAU	Level-2-260C-1 YEAR	-40 to 85	0190	<a href="#">Samples</a>
TPS40190DRCT	ACTIVE	SON	DRC	10	250	Green (RoHS & no Sb/Br)	CU NIPDAU	Level-2-260C-1 YEAR	-40 to 85	0190	<a href="#">Samples</a>
TPS40190DRCTG4	ACTIVE	SON	DRC	10	250	Green (RoHS & no Sb/Br)	CU NIPDAU	Level-2-260C-1 YEAR	-40 to 85	0190	<a href="#">Samples</a>

(1) The marketing status values are defined as follows:

**ACTIVE:** Product device recommended for new designs.

**LIFEBUY:** TI has announced that the device will be discontinued, and a lifetime-buy period is in effect.

**NRND:** Not recommended for new designs. Device is in production to support existing customers, but TI does not recommend using this part in a new design.

**PREVIEW:** Device has been announced but is not in production. Samples may or may not be available.

**OBSELETE:** TI has discontinued the production of the device.

(2) Eco Plan - The planned eco-friendly classification: Pb-Free (RoHS), Pb-Free (RoHS Exempt), or Green (RoHS & no Sb/Br) - please check <http://www.ti.com/productcontent> for the latest availability information and additional product content details.

**TBD:** The Pb-Free/Green conversion plan has not been defined.

**Pb-Free (RoHS):** TI's terms "Lead-Free" or "Pb-Free" mean semiconductor products that are compatible with the current RoHS requirements for all 6 substances, including the requirement that lead not exceed 0.1% by weight in homogeneous materials. Where designed to be soldered at high temperatures, TI Pb-Free products are suitable for use in specified lead-free processes.

**Pb-Free (RoHS Exempt):** This component has a RoHS exemption for either 1) lead-based flip-chip solder bumps used between the die and package, or 2) lead-based die adhesive used between the die and leadframe. The component is otherwise considered Pb-Free (RoHS compatible) as defined above.

**Green (RoHS & no Sb/Br):** TI defines "Green" to mean Pb-Free (RoHS compatible), and free of Bromine (Br) and Antimony (Sb) based flame retardants (Br or Sb do not exceed 0.1% by weight in homogeneous material)

(3) MSL, Peak Temp. -- The Moisture Sensitivity Level rating according to the JEDEC industry standard classifications, and peak solder temperature.

(4) Multiple Top-Side Markings will be inside parentheses. Only one Top-Side Marking contained in parentheses and separated by a "~" will appear on a device. If a line is indented then it is a continuation of the previous line and the two combined represent the entire Top-Side Marking for that device.

**Important Information and Disclaimer:** The information provided on this page represents TI's knowledge and belief as of the date that it is provided. TI bases its knowledge and belief on information provided by third parties, and makes no representation or warranty as to the accuracy of such information. Efforts are underway to better integrate information from third parties. TI has taken and continues to take reasonable steps to provide representative and accurate information but may not have conducted destructive testing or chemical analysis on incoming materials and chemicals. TI and TI suppliers consider certain information to be proprietary, and thus CAS numbers and other limited information may not be available for release.

In no event shall TI's liability arising out of such information exceed the total purchase price of the TI part(s) at issue in this document sold by TI to Customer on an annual basis.



**TAPE AND REEL INFORMATION**

**QUADRANT ASSIGNMENTS FOR PIN 1 ORIENTATION IN TAPE**

\*All dimensions are nominal

Device	Package Type	Package Drawing	Pins	SPQ	Reel Diameter (mm)	Reel Width W1 (mm)	A0 (mm)	B0 (mm)	K0 (mm)	P1 (mm)	W (mm)	Pin1 Quadrant
TPS40190DRCR	SON	DRC	10	3000	330.0	12.4	3.3	3.3	1.1	8.0	12.0	Q2
TPS40190DRCT	SON	DRC	10	250	180.0	12.4	3.3	3.3	1.1	8.0	12.0	Q2

**TAPE AND REEL BOX DIMENSIONS**

\*All dimensions are nominal

Device	Package Type	Package Drawing	Pins	SPQ	Length (mm)	Width (mm)	Height (mm)
TPS40190DRCR	SON	DRC	10	3000	367.0	367.0	35.0
TPS40190DRCT	SON	DRC	10	250	210.0	185.0	35.0

DRC (S-PVSON-N10)

PLASTIC SMALL OUTLINE NO-LEAD



4204102-3/L 09/11

- NOTES:
- All linear dimensions are in millimeters. Dimensioning and tolerancing per ASME Y14.5M-1994.
  - This drawing is subject to change without notice.
  - Small Outline No-Lead (SON) package configuration.
  - The package thermal pad must be soldered to the board for thermal and mechanical performance, if present.
  - See the additional figure in the Product Data Sheet for details regarding the exposed thermal pad features and dimensions, if present



# THERMAL PAD MECHANICAL DATA

DRC (S-PVSON-N10)

PLASTIC SMALL OUTLINE NO-LEAD

## THERMAL INFORMATION

This package incorporates an exposed thermal pad that is designed to be attached directly to an external heatsink. The thermal pad must be soldered directly to the printed circuit board (PCB). After soldering, the PCB can be used as a heatsink. In addition, through the use of thermal vias, the thermal pad can be attached directly to the appropriate copper plane shown in the electrical schematic for the device, or alternatively, can be attached to a special heatsink structure designed into the PCB. This design optimizes the heat transfer from the integrated circuit (IC).

For information on the Quad Flatpack No-Lead (QFN) package and its advantages, refer to Application Report, QFN/SON PCB Attachment, Texas Instruments Literature No. SLUA271. This document is available at [www.ti.com](http://www.ti.com).

The exposed thermal pad dimensions for this package are shown in the following illustration.

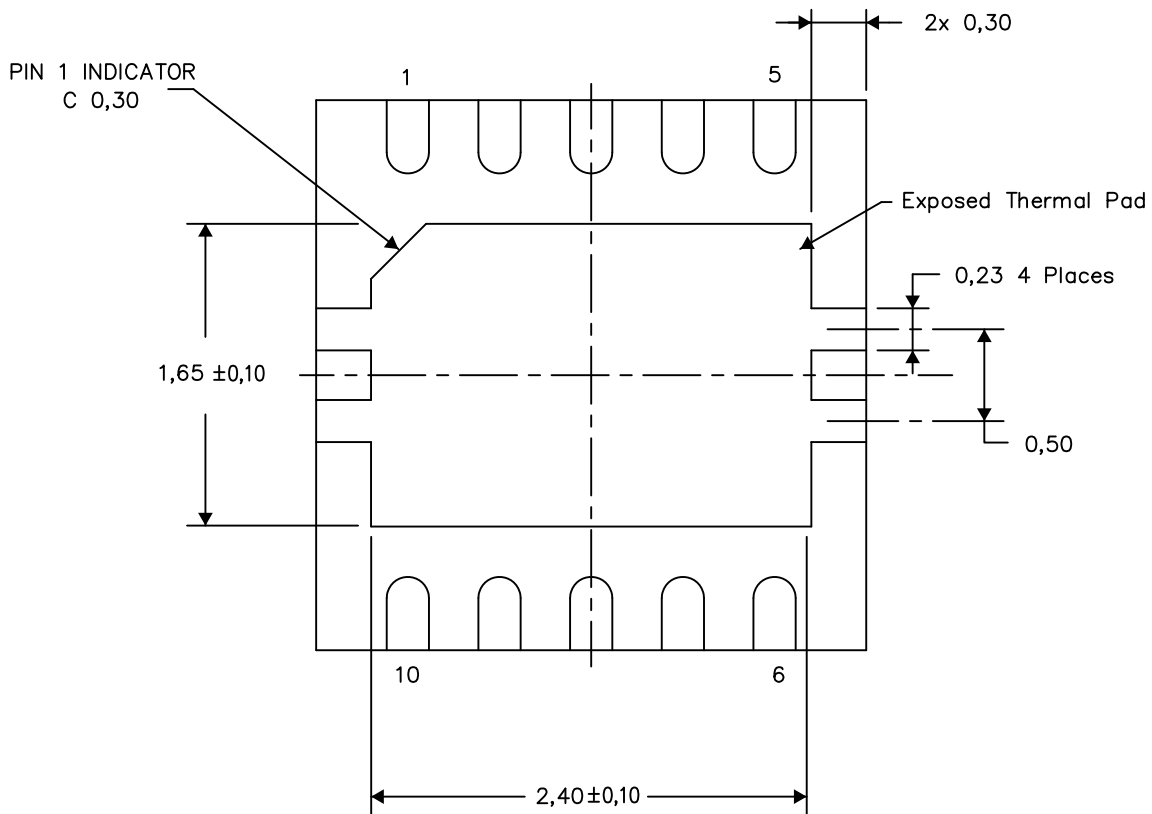

Bottom View

Exposed Thermal Pad Dimensions

4206565-3/R 03/13

NOTE: A. All linear dimensions are in millimeters



## IMPORTANT NOTICE

Texas Instruments Incorporated and its subsidiaries (TI) reserve the right to make corrections, enhancements, improvements and other changes to its semiconductor products and services per JESD46, latest issue, and to discontinue any product or service per JESD48, latest issue. Buyers should obtain the latest relevant information before placing orders and should verify that such information is current and complete. All semiconductor products (also referred to herein as "components") are sold subject to TI's terms and conditions of sale supplied at the time of order acknowledgment.

TI warrants performance of its components to the specifications applicable at the time of sale, in accordance with the warranty in TI's terms and conditions of sale of semiconductor products. Testing and other quality control techniques are used to the extent TI deems necessary to support this warranty. Except where mandated by applicable law, testing of all parameters of each component is not necessarily performed.

TI assumes no liability for applications assistance or the design of Buyers' products. Buyers are responsible for their products and applications using TI components. To minimize the risks associated with Buyers' products and applications, Buyers should provide adequate design and operating safeguards.

TI does not warrant or represent that any license, either express or implied, is granted under any patent right, copyright, mask work right, or other intellectual property right relating to any combination, machine, or process in which TI components or services are used. Information published by TI regarding third-party products or services does not constitute a license to use such products or services or a warranty or endorsement thereof. Use of such information may require a license from a third party under the patents or other intellectual property of the third party, or a license from TI under the patents or other intellectual property of TI.

Reproduction of significant portions of TI information in TI data books or data sheets is permissible only if reproduction is without alteration and is accompanied by all associated warranties, conditions, limitations, and notices. TI is not responsible or liable for such altered documentation. Information of third parties may be subject to additional restrictions.

Resale of TI components or services with statements different from or beyond the parameters stated by TI for that component or service voids all express and any implied warranties for the associated TI component or service and is an unfair and deceptive business practice. TI is not responsible or liable for any such statements.

Buyer acknowledges and agrees that it is solely responsible for compliance with all legal, regulatory and safety-related requirements concerning its products, and any use of TI components in its applications, notwithstanding any applications-related information or support that may be provided by TI. Buyer represents and agrees that it has all the necessary expertise to create and implement safeguards which anticipate dangerous consequences of failures, monitor failures and their consequences, lessen the likelihood of failures that might cause harm and take appropriate remedial actions. Buyer will fully indemnify TI and its representatives against any damages arising out of the use of any TI components in safety-critical applications.

In some cases, TI components may be promoted specifically to facilitate safety-related applications. With such components, TI's goal is to help enable customers to design and create their own end-product solutions that meet applicable functional safety standards and requirements. Nonetheless, such components are subject to these terms.

No TI components are authorized for use in FDA Class III (or similar life-critical medical equipment) unless authorized officers of the parties have executed a special agreement specifically governing such use.

Only those TI components which TI has specifically designated as military grade or "enhanced plastic" are designed and intended for use in military/aerospace applications or environments. Buyer acknowledges and agrees that any military or aerospace use of TI components which have **not** been so designated is solely at the Buyer's risk, and that Buyer is solely responsible for compliance with all legal and regulatory requirements in connection with such use.

TI has specifically designated certain components as meeting ISO/TS16949 requirements, mainly for automotive use. In any case of use of non-designated products, TI will not be responsible for any failure to meet ISO/TS16949.

### Products

Audio	<a href="http://www.ti.com/audio">www.ti.com/audio</a>
Amplifiers	<a href="http://amplifier.ti.com">amplifier.ti.com</a>
Data Converters	<a href="http://dataconverter.ti.com">dataconverter.ti.com</a>
DLP® Products	<a href="http://www.dlp.com">www.dlp.com</a>
DSP	<a href="http://dsp.ti.com">dsp.ti.com</a>
Clocks and Timers	<a href="http://www.ti.com/clocks">www.ti.com/clocks</a>
Interface	<a href="http://interface.ti.com">interface.ti.com</a>
Logic	<a href="http://logic.ti.com">logic.ti.com</a>
Power Mgmt	<a href="http://power.ti.com">power.ti.com</a>
Microcontrollers	<a href="http://microcontroller.ti.com">microcontroller.ti.com</a>
RFID	<a href="http://www.ti-rfid.com">www.ti-rfid.com</a>
OMAP Applications Processors	<a href="http://www.ti.com/omap">www.ti.com/omap</a>
Wireless Connectivity	<a href="http://www.ti.com/wirelessconnectivity">www.ti.com/wirelessconnectivity</a>

### Applications

Automotive and Transportation	<a href="http://www.ti.com/automotive">www.ti.com/automotive</a>
Communications and Telecom	<a href="http://www.ti.com/communications">www.ti.com/communications</a>
Computers and Peripherals	<a href="http://www.ti.com/computers">www.ti.com/computers</a>
Consumer Electronics	<a href="http://www.ti.com/consumer-apps">www.ti.com/consumer-apps</a>
Energy and Lighting	<a href="http://www.ti.com/energy">www.ti.com/energy</a>
Industrial	<a href="http://www.ti.com/industrial">www.ti.com/industrial</a>
Medical	<a href="http://www.ti.com/medical">www.ti.com/medical</a>
Security	<a href="http://www.ti.com/security">www.ti.com/security</a>
Space, Avionics and Defense	<a href="http://www.ti.com/space-avionics-defense">www.ti.com/space-avionics-defense</a>
Video and Imaging	<a href="http://www.ti.com/video">www.ti.com/video</a>

### TI E2E Community

[e2e.ti.com](http://e2e.ti.com)