

Digital Control Compatible Synchronous Buck Gate Drivers with Current Sense Conditioning Amplifier

 Check for Samples: [UCD7230](#)

FEATURES

- Input from Digital Controller Sets Operating Frequency and Duty Cycle
- Up to 2-MHz Switching Frequency
- Dual Current Limit Protection with Independently Adjustable Thresholds
- Fast Current Sense Circuit with Adjustable Blanking Interval Prevents Catastrophic Current Levels
- Digital Output Current Limit Flag
- Low Offset, Gain of 48, Differential Current Sense Amplifier
- 3.3-V, 10-mA Internal Regulator
- Dual TrueDrive™ High-Current Drivers
- 10-ns Typical Rise/Fall Times with 2.2-nF Loads
- 4.5-V to 15.5-V Supply Voltage Range

APPLICATIONS

- Digitally-Controlled Synchronous-Buck Power Stages for Single and Multi-Phase Applications
- Especially Suited for Use with UCD91xx or UCD95xx Controllers
- High-Current Multi-Phase VRM/EVRD Regulators for Desktop, Server, Telecom and Notebook Processors
- Digitally-Controlled Synchronous-Buck Power Supplies Using μ Cs or the TMS320™ DSP Family

DESCRIPTION

The UCD7230 is part of the UCD7K family of digital control compatible drivers for applications utilizing digital control techniques or applications requiring fast local peak current limit protection.

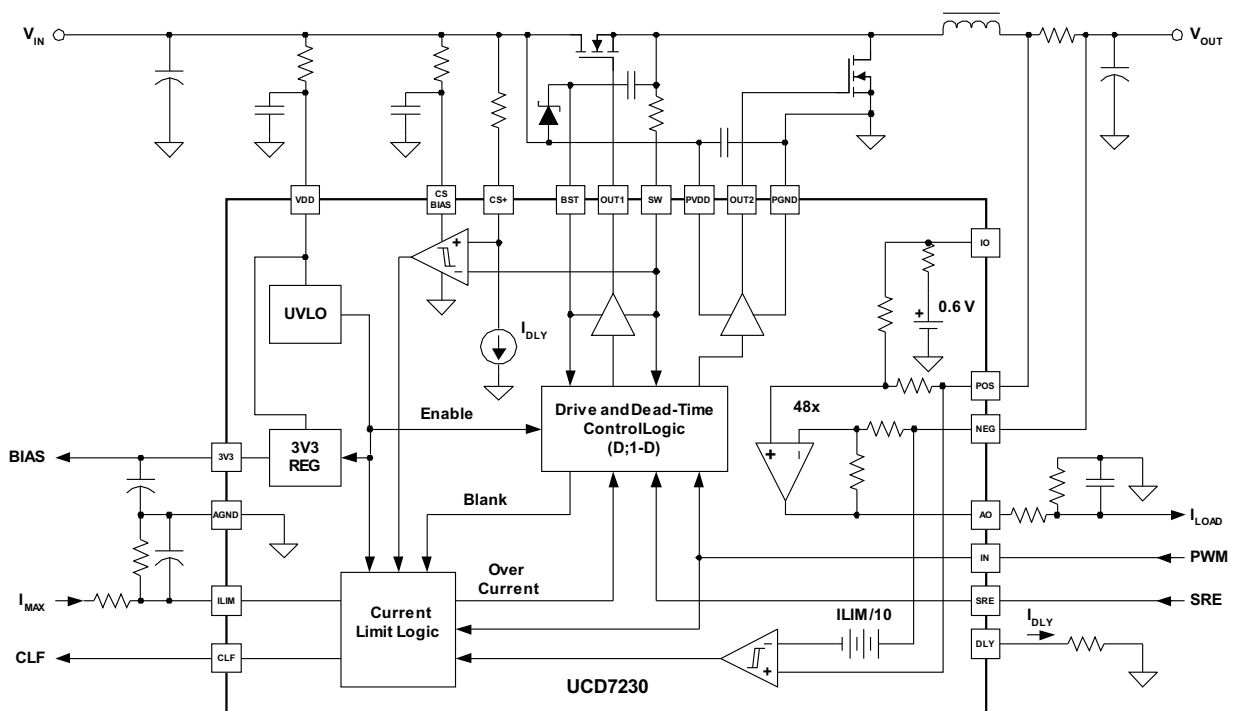

Please be aware that an important notice concerning availability, standard warranty, and use in critical applications of Texas Instruments semiconductor products and disclaimers thereto appears at the end of this data sheet.

TrueDrive, PowerPAD are trademarks of Texas Instruments.

The UCD7230 is a MOSFET gate driver specifically designed for synchronous buck applications. It is ideally suited to provide the bridge between digital controllers such as the UCD91xx or the UCD95xx and the power stage. With cycle-by-cycle current limit protection, the UCD7230 device protects the power stage from faulty input signals or excessive load currents.

The UCD7230 includes high-side and low-side gate drivers which utilize Texas Instrument's TrueDrive™ output architecture. This architecture delivers rated current into the gate capacitance of a MOSFET during the Miller plateau region of the switching. Furthermore, the UCD7230 offers a low offset differential amplifier with a fixed gain of 48. This amplifier greatly simplifies the task of conditioning small current sense signals inherent in high efficiency buck converters.

The UCD7230 includes a 3.3-V, 10-mA linear regulator to provide power to digital controllers such as the UCD91xx. The UCD7230 is compatible with standard 3.3-V I/O ports of the UCD91xx, the TMS320™ family DSPs, μ Cs, or ASICs.

The UCD7230 is offered in PowerPAD™ HTSSOP or space-saving QFN packages. Package pin out has been carefully designed for optimal board layout

SIMPLIFIED APPLICATION DIAGRAMS

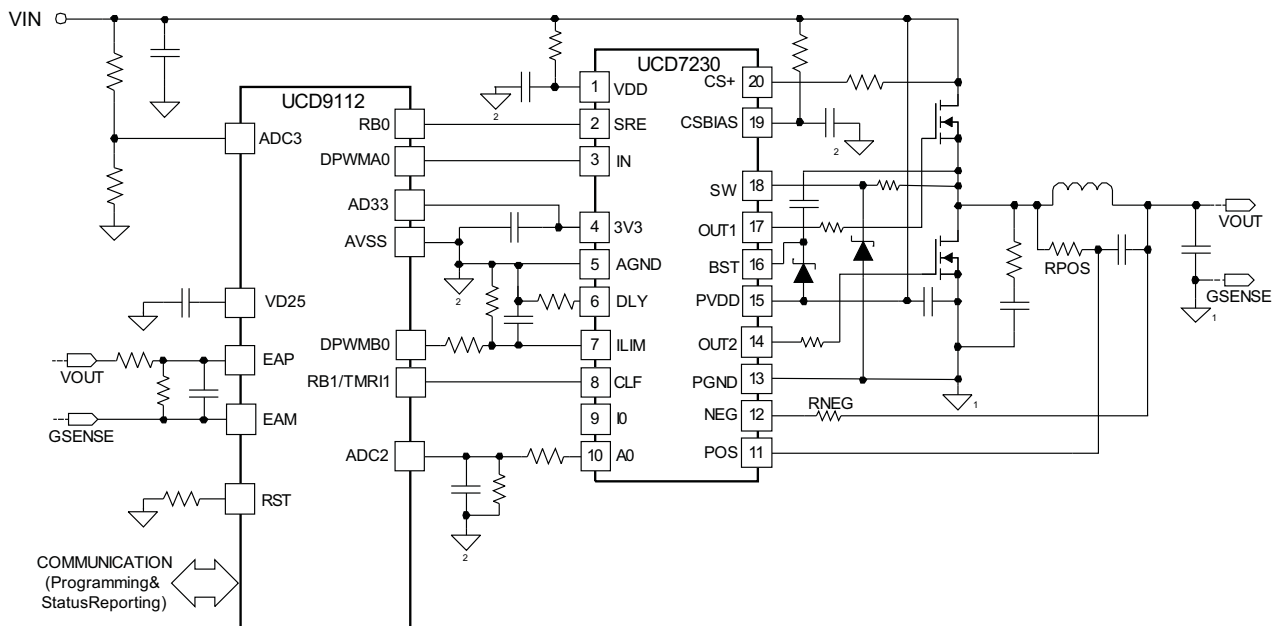

Figure 1. Single-Phase Synchronous Buck Converter using UCD9112 and one UCD7230

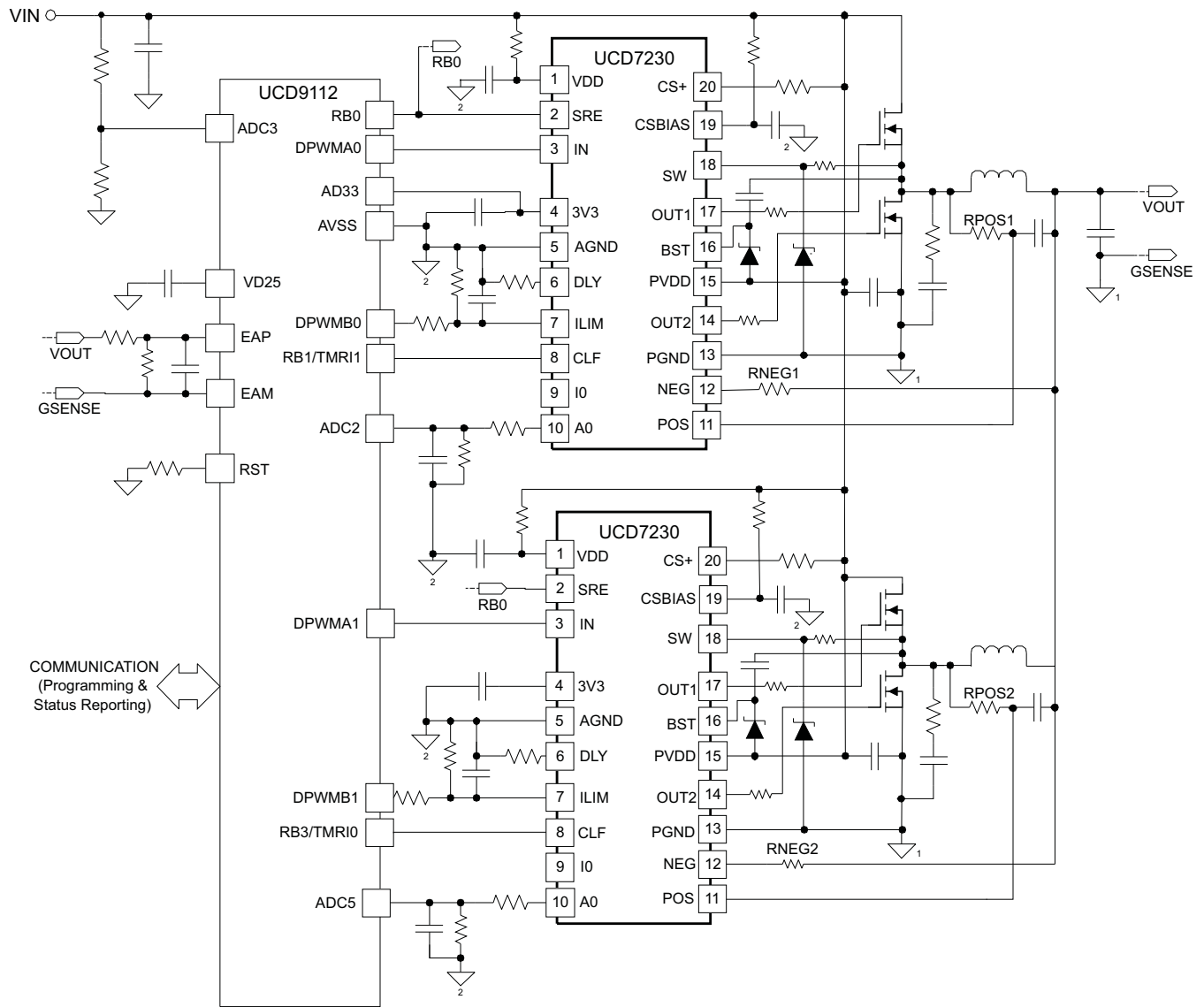
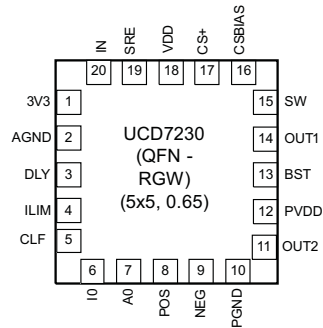

Figure 2. Multi-Phase Synchronous Buck Converter using UCD9112 and two UCD7230

CONNECTION DIAGRAMS



ORDERING INFORMATION⁽¹⁾ ⁽²⁾

TEMPERATURE RANGE	PACKAGED DEVICES	
	PowerPAD™ HTSSOP-20 (PWP)	QFN-20 (RGW)
-40°C to + 125°C	UCD7230PWP	UCD7230RGW

- (1) These products are packaged in Pb-Free and green lead finish of Pd-Ni-Au which is compatible with MSL level 1 at 255-260°C peak reflow temperature to be compatible with either lead free or Sn/Pb soldering operations.
- (2) QFN-20 (RGW) package is available taped and reeled. Add T suffix to device type (e.g. UCD7230RGW) to order quantities of 1,000 devices per reel.

ABSOLUTE MAXIMUM RATINGS⁽¹⁾

over operating free-air temperature range (unless otherwise noted)

PARAMETER		CONDITION	VALUE	UNIT
V _{DD}	Supply voltage		16	V
B _{ST}			SW + 16	
I _{DD}	Supply current	Quiescent	20	mA
		Switching, T _A = 25°C, V _{DD} = 12 V	200	
V _O	Output gate drive voltage	OUT1, BST	-1 V to 36	V V
		OUT2	-1 V to V _{DD} +0.3	
I _{OUT(sink)}	Output gate drive current	OUT1	4.0	A
I _{OUT(source)}		OUT1	-2.0	
I _{OUT(sink)}		OUT2	4.0	
I _{OUT(source)}		OUT2	-4.0	
	Analog inputs	SW	-1 to 20	V
		CS+	-0.3 to 20	
		CSBIAS	-0.3 to 16	
		POS, NEG	-0.3 to 5.6	
		ILIM, DLY, I0	-0.3 to 3.6	
	Analog output	A0	-0.3 to 3.6	
	Digital I/O's	IN, SRE, CLF	-0.3 to 3.6	
	Power dissipation	T _A = 25°C (PWP-20 package)	2.67	W
		T _A = 25°C (QFN-20 package)		
T _J	Junction operating temperature		-55 to 150	°C
T _{stg}	Storage temperature		-65 to 150	
HBM	ESD rating	Human body model	2000	V
CDM		Charged device model	500	
	Lead temperature (soldering, 10 sec)		300	°C

- (1) Stresses beyond those listed under “absolute maximum ratings” may cause permanent damage to the device. These are stress ratings only and functional operation of the device at these or any other condition beyond those indicated is not implied. Exposure to absolute maximum rated conditions for extended periods may affect device reliability. All voltages are with respect to GND. Currents are positive into, negative out of the specified terminal. Consult company packaging information for thermal limitations and considerations of packages.

ELECTRICAL CHARACTERISTICS

$V_{DD} = P_{VDD} = 12\text{ V}$, $4.7\text{-}\mu\text{F}$ from V_{DD} to A_{GND} , $1\text{ }\mu\text{F}$ from P_{VDD} to P_{GND} , $0.1\text{ }\mu\text{F}$ from CS_{BIAS} to $AGND$, $0.22\text{ }\mu\text{F}$ from BST to SW , $T_A = T_J = -40^\circ\text{C}$ to $+125^\circ\text{C}$, $R_{CS+} = 5\text{ k}\Omega$, $R_{DLY} = 50\text{ k}\Omega$ over operating free-air temperature range (unless otherwise noted).

PARAMETER		TEST CONDITIONS	MIN	TYP	MAX	UNIT
SUPPLY						
	Supply current, off	$V_{DD} = 4.2\text{ V}$		500	700	μA
	Supply current	Outputs not switching IN = LOW		5	8	mA
LOW-VOLTAGE UNDER-VOLTAGE LOCKOUT						
	VDD UVLO ON	V_{DD} rising	4.25	4.50	4.75	V
	VDD UVLO OFF	V_{DD} falling	4.00	4.25	4.50	
	VDD UVLO hysteresis		100	250	400	mV
REFERENCE / EXTERNAL BIAS SUPPLY						
	3V3 initial set point	$T_A = 25^\circ\text{C}$	3.267	3.3	3.333	V
	3V3 over temperature		3.234	3.3	3.366	
	3V3 load regulation	$I_{LOAD} = 1\text{ mA to }10\text{ mA}$, $V_{DD} = 5\text{ V}$		1	7	mV
	3V3 line regulation	$V_{DD} = 4.75\text{ V to }12\text{ V}$, $I_{LOAD} = 10\text{ mA}$		3	10	
	Short circuit current	$V_{DD} = 4.75\text{ V to }12\text{ V}$	11	20		mA
	3V3 OK threshold, ON	3.3 V rising	2.8	3	3.2	V
	3V3 OK threshold, OFF	3.3 V falling	2.6	2.8	3.0	
INPUT SIGNAL (IN)						
INHigh	Positive-going input threshold voltage		1.6	1.9	2.2	V
INLow	Negative-going input threshold voltage		1.0	1.3	1.6	
INHigh – INLow	Input voltage hysteresis		0.4	0.6	0.8	
	Input resistance to AGND		50	100	150	k Ω
	Frequency ceiling		2			MHz
CURRENT LIMIT (ILIM)						
	ILIM internal voltage setpoint	$I_{LIM} = \text{OPEN}$	0.47	0.50	0.53	V
	ILIM input impedance		20	42	65	k Ω
	CLF output high level	$I_{LOAD} = 4\text{ mA}$	2.7			V
	CLF output low level	$I_{LOAD} = 4\text{ mA}$			0.6	
	Propagation delay from IN to reset CLF	2nd IN rising to CLF falling after a current limit event		15	35	ns
CURRENT SENSE COMPARATOR (OUTPUT SENSE)						
	CS threshold (POS - NEG)	$I_{LIM} = \text{open}$	40	50	60	mV
		$I_{LIM} = 3.3\text{ V}$	80	100	120	
		$I_{LIM} = 0.75\text{ V}$	60	75	90	
		$I_{LIM} = 0.25\text{ V}$	15	25	35	
	Propagation delay from POS to OUT1 falling ⁽¹⁾	$I_{LIM} = \text{open}$, CS = threshold + 60 mV		90		ns
	Propagation delay from POS to CLF ⁽¹⁾	$I_{LIM} = \text{open}$, CS = threshold + 60 mV		100		

(1) As designed and characterized. Not 100% tested in production.

ELECTRICAL CHARACTERISTICS (continued)

$V_{DD} = P_{VDD} = 12\text{ V}$, $4.7\text{-}\mu\text{F}$ from V_{DD} to A_{GND} , $1\text{ }\mu\text{F}$ from P_{VDD} to P_{GND} , $0.1\text{ }\mu\text{F}$ from $CSBIAS$ to $AGND$, $0.22\text{ }\mu\text{F}$ from BST to SW , $T_A = T_J = -40^\circ\text{C}$ to $+125^\circ\text{C}$, $R_{CS+} = 5\text{ k}\Omega$, $R_{DLY} = 50\text{ k}\Omega$ over operating free-air temperature range (unless otherwise noted).

PARAMETER	TEST CONDITIONS	MIN	TYP	MAX	UNIT	
CURRENT SENSE COMPARATOR (INPUT SENSE)						
CS threshold	$R_{DLY} = 24.3\text{ k}\Omega$ (CSBIAS-CS+)	170	235	300	mV	
	$R_{DLY} = 49.9\text{ k}\Omega$ (CSBIAS-CS+)	90	114	140		
CS blanking time ⁽²⁾	$R_{DLY} = 24.3\text{ k}\Omega$, IN rising to OUT1, IN falling to OUT2, $V_{DD} = 6\text{ V}$		120		ns	
	$R_{DLY} = 49.9\text{ k}\Omega$, IN rising to OUT1, IN falling to OUT2, $V_{DD} = 6\text{ V}$		230			
R_{DELAY} range ⁽²⁾		24.3	50.0	100.0	k Ω	
Propagation delay from CS+ to OUT1 ⁽²⁾	CS = threshold + 60mV		80		ns	
Propagation delay from CS+ to CLF ⁽²⁾			70			
CURRENT SENSE AMP						
V_{OO}	Output offset voltage	$I_O = \text{OPEN}$; POS = NEG = 1.25 V; measure AO - IO	-100	0	100	mV
	Closed loop dc gain	$I_O = \text{FLOAT}$; $V_{POS} = 1.26\text{ V}$; $V_{NEG} = 1.25\text{ V}$, $R_{POS} = R_{NEG} = 0$	46	48	50	V/V
	Input impedance	POS = 1.25 V, NEG = 1.29 V, $R = (POS - NEG) / (I_{POS} - I_{NEG})$	5.5	8.3	12	k Ω
V_{CM}	Input Common Mode Voltage Range	$V_{CM(max)}$ is limited to $(V_{DD} - 1.2V)$, $R_{POS} = 0$	0		5.6	V
A0_Vol	Minimum Output Voltage	$V_{POS} = 1.2\text{ V}$; $V_{NEG} = 1.3\text{ V}$; $A0_{ISINK} = 250\text{ }\mu\text{A}$		0.15	0.3	V
A0_Voh	Maximum Output Voltage	$V_{POS} = 1.3\text{ V}$; $V_{NEG} = 1.2\text{ V}$; $A0_{ISOURCE} = 500\text{ }\mu\text{A}$	3	3.1	3.5	
	Input Bias Current, POS or NEG	$I_O = \text{FLOAT}$; $V_{POS} = V_{NEG} = 0.8\text{ V}$ to 5.0 V , $R_{POS} = R_{NEG} = 0$	-2		30	μA
ZERO CURRENT REFERENCE (IO)						
	Reference voltage	Measured at IO	0.54	0.6	0.66	V
	Input transition voltage	With respect to IO reference	10	60	120	mV
I_O	Output impedance	$I_{ZERO} = 0.6\text{ V}$	10	15	21	k Ω

(2) As designed and characterized. Not 100% tested in production.

ELECTRICAL CHARACTERISTICS (continued)

$V_{DD} = P_{VDD} = 12\text{ V}$, $4.7\text{-}\mu\text{F}$ from V_{DD} to A_{GND} , $1\text{ }\mu\text{F}$ from P_{VDD} to P_{GND} , $0.1\text{ }\mu\text{F}$ from CS_{BIAS} to $AGND$, $0.22\text{ }\mu\text{F}$ from BST to SW , $T_A = T_J = -40^\circ\text{C}$ to $+125^\circ\text{C}$, $R_{CS+} = 5\text{ k}\Omega$, $R_{DLY} = 50\text{ k}\Omega$ over operating free-air temperature range (unless otherwise noted).

PARAMETER		TEST CONDITIONS	MIN	TYP	MAX	UNIT
LOW-SIDE OUTPUT DRIVER (OUT2)						
	Source current ⁽³⁾	$V_{DD} = 12\text{ V}$, IN = high, OUT2 = 5 V		2.2		A
	Sink current ⁽³⁾	$V_{DD} = 12\text{ V}$, IN = low, OUT2 = 5 V		3.5		
	Source current ⁽³⁾	$V_{DD} = 4.75\text{ V}$, IN = high, OUT2 = 0		1.6		
	Sink current ⁽³⁾	$V_{DD} = 4.75\text{ V}$, IN = low, OUT2 = 4.75 V		2		
	Rise time ⁽³⁾	$C_{LOAD} = 2.2\text{ nF}$, $V_{DD} = 12\text{ V}$		15		ns
	Fall time ⁽³⁾	$C_{LOAD} = 2.2\text{ nF}$, $V_{DD} = 12\text{ V}$		15		
	Output with $V_{DD} < UVLO$	$V_{DD} = 1.0\text{ V}$, $I_{sink} = 10\text{ mA}$		0.8	1.2	V
	Propagation delay from IN to OUT2 ⁽³⁾	$C_{LOAD} = 2.2\text{ nF}$, IN rising, SW = 2.5 V, BST = PVDD = VDD = 12 V		30		ns
HIGH-SIDE OUTPUT DRIVER (OUT1)						
	Source current ⁽³⁾	$V_{DD} = 12\text{ V}$, BST = 12 V IN = High, OUT1 = 5 V		1.7		A
	Sink current ⁽³⁾	$V_{DD} = 12\text{ V}$, BST = 12 V IN = Low, OUT1 = 5 V		3.5		
	Source current ⁽³⁾	$V_{DD} = 4.75\text{ V}$, BST = 4.75 V, IN = High, OUT1 = 0		1		
	Sink current ⁽³⁾	$V_{DD} = 4.75\text{ V}$, BST = 4.75 V, IN = Low, OUT1 = 4.75 V		2.4		
	Rise time ⁽³⁾	$C_{LOAD} = 2.2\text{ nF}$ OUT1 to SW, VDD = 12 V		20		ns
	Fall time ⁽³⁾	$C_{LOAD} = 2.2\text{ nF}$ OUT1 to SW, VDD = 12 V		15		
	Propagation delay from IN to OUT1 ⁽³⁾	$C_{LOAD} = 2.2\text{ nF}$, IN falling, SW = 2.5 V, BST = PVDD = VDD = 12 V		30		

(3) As designed and characterized. Not 100% tested in production.

DEVICE INFORMATION
TERMINAL FUNCTIONS

TERMINAL			I/O	DESCRIPTION
NAME	UCD7230			
	HTSSOP-20	QFN-20		
VDD	1	18	-	Supply input pin to power the internal circuitry except the driver outputs. The UCD7230 accepts an input range of 4.5 V to 15.5 V.
SRE	2	19	I	Synchronous Rectifier Enable. The SRE pin is a high impedance digital input capable of accepting 3.3-V logic level signals, used to disable the synchronous rectifier switch. The synchronous rectifier is disabled when this signal is low. A Schmitt trigger input comparator desensitizes this pin from external noise.
IN	3	20	I	The IN pin is a high impedance digital input capable of accepting 3.3-V logic level signals up to 2 MHz. A Schmitt trigger input comparator desensitizes this pin from external noise.
3V3	4	1	O	Regulated 3.3-V rail. The onboard linear voltage regulator is capable of sourcing up to 10 mA of current. Bypass with 0.22- μ F ceramic capacitance from this pin to analog ground, AGND.
AGND	5	2	-	Analog ground return.
DLY	6	3	I	Requires a resistor to AGND for setting the current sense blanking time for both the high-side and low-side current sense comparators. The value of this resistor in conjunction with the resistor in series with the CS+ pin sets the high side current sense threshold.
ILIM	7	4	I	Output current limit threshold set pin. The output current threshold is 1/10 th of the value set on this pin. If left floating the voltage on this pin is 0.55 V. The voltage on the ILIM pin can range from 0.25 V to 1V to set the threshold from 25 mV to 100 mV.
CLF	8	5	O	Current Limit Flag. The CLF signal is a 3.3-V digital output which is latched high after an over current event, triggered by either of the two current sense comparators and reset after two rising edges received on the IN pin.
IO	9	6	I	Sets the current sense linear amplifier "Zero" output level. The default value is 0.6 V which allows negative current measurement.
AO	10	7	O	Current sense linear amplifier output. The output voltage level on this pin represents the average output current. Any value below the level on the IO pin represents negative output current.
POS	11	8	I	Non-inverting input of the output current sense amplifier and current limit comparator.
NEG	12	9	I	Inverting input of the output current sense amplifier and current limit comparator.
PGND	13	10	-	Power ground return. This pin should be connected close to the source of the low-side synchronous rectifier MOSFET.
OUT2	14	11	I	The low-side high-current TrueDrive™ driver output. Drives the gate of the low-side synchronous MOSFET between PVDD and PGND.
PVDD	15	12	-	Supply pin provides power for the output drivers. It is not connected internally to the VDD supply rail. The bypass capacitor for this pin should be returned to PGND.
BST	16	13	I	Floating OUT1 driver supply powered by an external Schottky diode from the PVDD pin during the synchronous MOSFET on time.
OUT1	17	14	I	The high-side high-current TrueDrive™ driver output. Drives the gate of the high-side buck MOSFET between SW and BST.
SW	18	15	I/O	OUT1 gate drive return and square wave input to output inductor.
CSBIAS	19	16	I	Supply pin for the high-side current sense comparator.
CS+	20	17	I	Non-inverting Input for the high side current sense comparator. A resistor connected between this pin and the high side MOSFET drain, in conjunction with the DLY resistor sets the high-side current limit threshold.

APPLICATION INFORMATION

Introduction

The UCD7230 is a synchronous buck driver with peak-current limiting. It is a member of the UCD7K family of digital compatible drivers suitable either for applications utilizing digital control techniques or analog applications that require local fast peak current limit protection.

In systems using the UCD7230, the feedback loop is closed externally and the IN signal represents the PWM information required to regulate the output voltage. The PWM signal may be implemented by either a digital or analog controller.

The UCD7230 has two over-current protection features, one that limits the peak current in the high-side switch and one that limits the output current. Both limits are individually programmable. The internal current sense blanking enables ease of design with real-world signals. In addition to over current limit protection, current sense signals can be conditioned by the on board amplifier for use by the system controller.

Supply Requirements

The UCD7230 operates on a supply range of 4.5 V to 15.5 V. The supply voltage should be applied to three pins, PVDD, VDD, and CSBIAS. PVDD is the supply pin for the lower driver, and has the greatest current demands. The supply connection to PVDD is also the point where an external Schottky diode provides current to the high side flying driver. PVDD should be bypassed to PGND with a low ESR ceramic capacitor. In the same fashion, the flying driver should be bypassed between BST and SW.

VDD and CSBIAS are less demanding supply pins, and should be resistively coupled to the supply voltage for isolation from noise generated by high current switching and parasitic board inductance. Use 33 Ω for CSBIAS and 1 Ω for VDD. VDD should be bypassed to AGND with a 4.7- μ F ceramic capacitor while CSBIAS should be bypassed to AGND with 0.1 μ F. Although the three supply pins are not internally connected, they must be biased to the same voltage. It is important that all bypassing be done with low parasitic inductance techniques to good ground planes.

PGND and AGND are the ground return connections to the chip. Ground plane construction should be used for both pins. For a MOSFET driver operating at high frequency, it is critical to minimize the stray inductance to minimize overshoot, undershoot, and ringing. The low output impedance of the drivers produces waveforms with high di/dt. This induces ringing in the parasitic inductances. It is highly desirable that the UCD7230 and the MOSFETs be collocated. PGND and the AGND pins should be connected to the PowerPAD™ of the package with two thin traces. It is critical to ensure that the voltage potential between these two pins does not exceed 0.3 V.

Although quiescent VDD current is low, total supply current depends on the gate drive output current required for the capacitive load and the switching frequency. Total supply current is the sum of quiescent VDD current and the average OUT current. Knowing the operating frequency and the MOSFET gate charge (Qg), average OUT current can be calculated from ($I_{OUT} = Qg \times f$), where f is the operating frequency.

Reference / External Bias Supply

The UCD7230 includes a series pass regulator to provide a regulated 3.3 V at the 3V3 pin that can be used to power other circuits such as the UCD91xx, a microcontroller or an ASIC. 3V3 can source 10 mA of current. For normal operation, place a 0.22- μ F ceramic capacitor between 3V3 and AGND.

Control Inputs

IN and SRE are high impedance digital inputs designed for 3.3-V logic-level signals. They both have 100-k Ω pull-down resistors. Schmitt Trigger input stage design immunizes the internal circuitry from external noise. IN is the command input for the upper driver, OUT1, and can function up to 2 MHz. SRE controls the function of the lower driver, OUT2. When SRE is false (low), OUT2 is held low. When SRE is true, OUT2 is inverted from OUT1 with appropriate delays that preclude cross conduction in the Buck MOSFETs.

Driver Stages

The driver outputs utilize Texas Instruments' TrueDrive™ architecture, which delivers rated current into the gate of a MOSFET when it is most needed, during the Miller plateau region of the switching transition. This provides best switching speeds and reduces switching losses. TrueDrive™ consists of pull-up/ pull-down circuits using bipolar and MOSFET transistors in parallel. This hybrid output stage also allows relatively constant current sourcing even at reduced supply voltages.

The low-side high-current output stage of the UCD7230 device is capable of sourcing 1.7-A and sinking 3.5-A current pulses and swings from PVDD to PGND. The high-side floating output driver is capable of sourcing 2.2-A and sinking 3.5-A peak-current pulses. This ratio of gate currents, common to synchronous buck applications, minimizes the possibility of parasitic turn on of the low-side power MOSFET due to dv/dt currents during the rising edge switching transition. See the typical curves of sink and source current in Figure 3 and Figure 4 below.

If further limiting of the rise or fall times to the power device is desired, an external resistance can be added between the output of the driver and the power MOSFET gate. The external resistor also helps remove power dissipation from the driver.

Driver outputs follow IN and SRE as previously described provided that VDD and 3V3 are above their respective under-voltage lockout thresholds. When the supplies are insufficient, the chip holds both OUT1 and OUT2 low.

It is worth reiterating the need mentioned in the supply section for sound high frequency design techniques in the circuit board layout and bypass capacitor selection and placement. Some applications may generate excessive ringing at the switch-inductor node. This ringing can drag SW to negative voltages that might cause functional irregularities. To prevent this, careful board layout and appropriate snubbing are essential. In addition, it may be appropriate to couple SW to the inductor with a 1-Ω resistor, and then bypass SW to PGND with a low impedance Schottky diode.

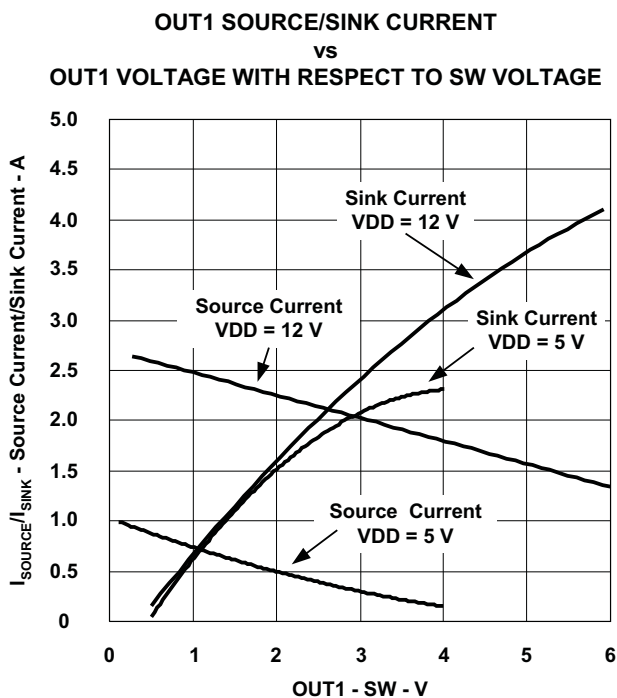

Figure 3.

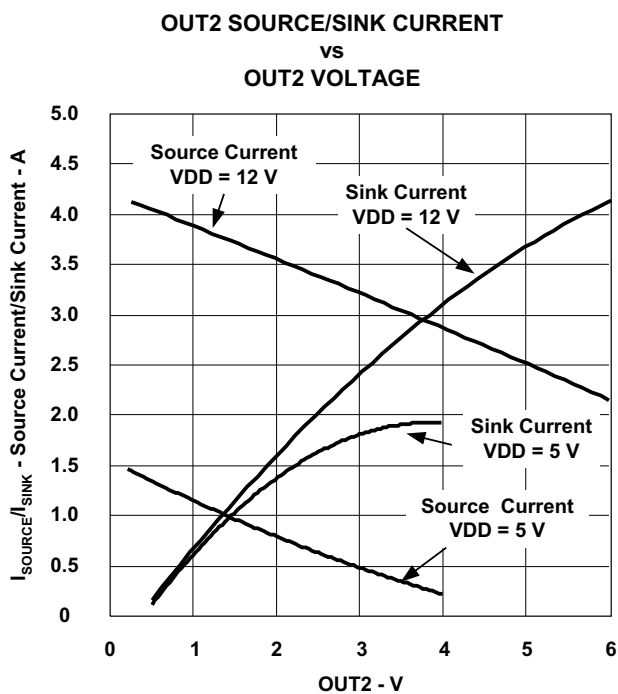

Figure 4.

Current Sensing and Overload Protection

Since the UCD7230 is physically collocated with the high-current elements of the power converter, it is logical that current be monitored by the chip. An internal instrumentation amplifier conditions current sense signals so that they can be used by the control chip generating the PWM signal.

POS and NEG are inputs to an instrumentation amplifier circuit. This amplifier has a nominal gain of 48 and presents its output at AO. This can be used to monitor either an external current sense shunt or a parallel RC around the buck inductor shown in Figure 5. The shunt yields the highest accuracy and will be insensitive to inductor core saturation effects. It comes with the price of added power dissipation. Using the shunt, AO is given by:

$$AO = (48 \times I_{OUT} \times R_{SHUNT}) + IO \quad (1)$$

The internal configuration of the instrumentation amplifier is such that AO is 0.6 V when POS – NEG = 0. Because of this output offset, the amplifier can accurately pass information for both positive and negative load current. The offset is controlled by IO. If IO is left to float, the offset is 0.6 V. 0.6 V is present at IO through an internal 10-kΩ resistor and should be bypassed to AGND. If a higher value of offset is desired, a voltage in excess of 0.66 V can be externally applied to IO. Once IO is forced above 0.66 V, the internal 10 kΩ is disconnected, and the AO output offset is now equal to the voltage applied to IO.

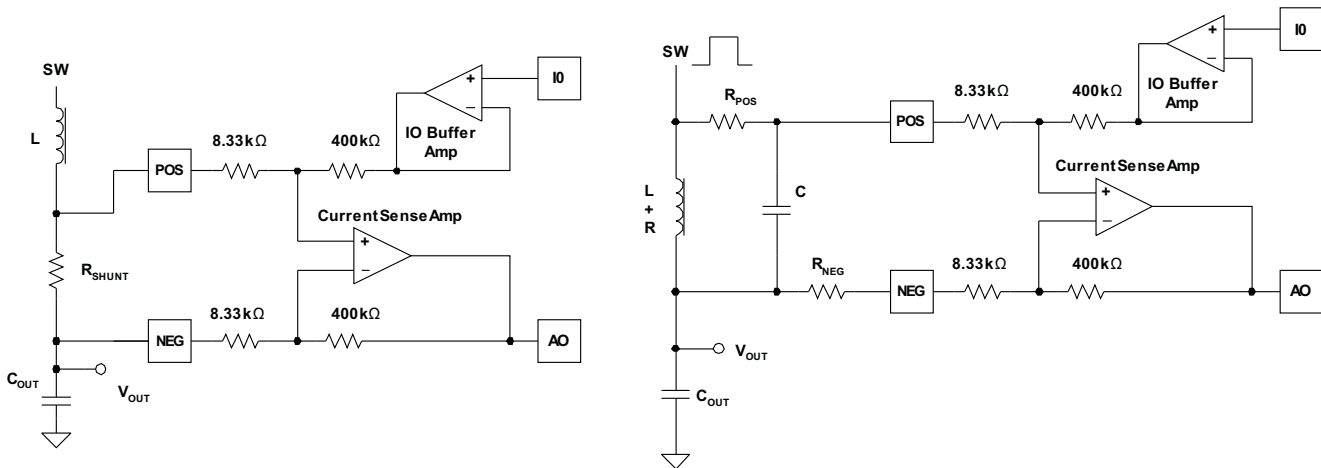

Figure 5. Current Sense Using External Shunt and Lossless Average Output Current Sensing Using DC Resistance of the Output Inductor.

Figure 5 also shows lossless current sensing utilizing an RC across the buck inductor to generate an analog of the IR drop on the copper of the inductor. As long as the $R_{POS} \times C$ time constant is the same as the L/R of the inductor and its parasitic equivalent series resistance, then the voltage on C is the same as the IR drop on the parasitic inductor resistance. A resistor, $R_{NEG} = R_{POS}$ is used for amplifier bias current cancellation. The transfer function of the amplifier is given by:

$$AO = (A \times I_{OUT} \times R_{COPPER}) + IO \quad (2)$$

With the addition of R_{POS} and R_{NEG} , the natural gain, A , of the current sense is predictably decreased as:

$$A = \frac{48}{1 + \left(\frac{R_{POS}}{8.33 \text{ k}\Omega} \right)} \tag{3}$$

For $R_{POS} \ll 8.33 \text{ k}\Omega$, the gain is 48. While the $400 \text{ k}\Omega$ and $8.33 \text{ k}\Omega$ are well matched, it is important to keep R_{POS} as small as possible since they have absolute variation from chip-to-chip and over temperature. The graph in Figure 6 shows the band of expected gain for A as a function of R_{POS} . The gain variation at $R_{POS} = 1 \text{ k}\Omega$ results in around $\pm 4\%$ error. However, the tolerance of the value of R in the inductor has a more significant effect on measurement accuracy as does the temperature coefficient of R . Copper has a temperature coefficient of approximately $3800 \text{ ppm}/^\circ\text{C}$. For a 100°C rise in winding temperature, the dc resistance of the inductor increases by 38%. The worst case scenario would be a cracked core or under-designed inductor in which cases the core could tend towards saturation. In that scenario, inductor current could change slope drastically and is not correctly modeled by the capacitor voltage.

Note that inferring inductor current by use of a parallel RC has an additional caveat. As long as $T_{RC} = R_{POS} C$ is the same as $T_{LR} = L/R$, then the voltage across C is the same as the IR drop across the equivalent R of the inductor. If the time constants don't match, the average voltage across C is still the same as the average voltage across R , but the indication of ripple current amplitude will be off. Furthermore, load transients results in reported current that appears to have overshoot or undershoot if T_{RC} is respectively faster or slower than T_{LR} .

While the amp faithfully passes the sensed dc current signal, it should be noted that the amplifier is bandwidth limited for normal switching frequencies. Therefore, AO represents a moving average of the sensed current.

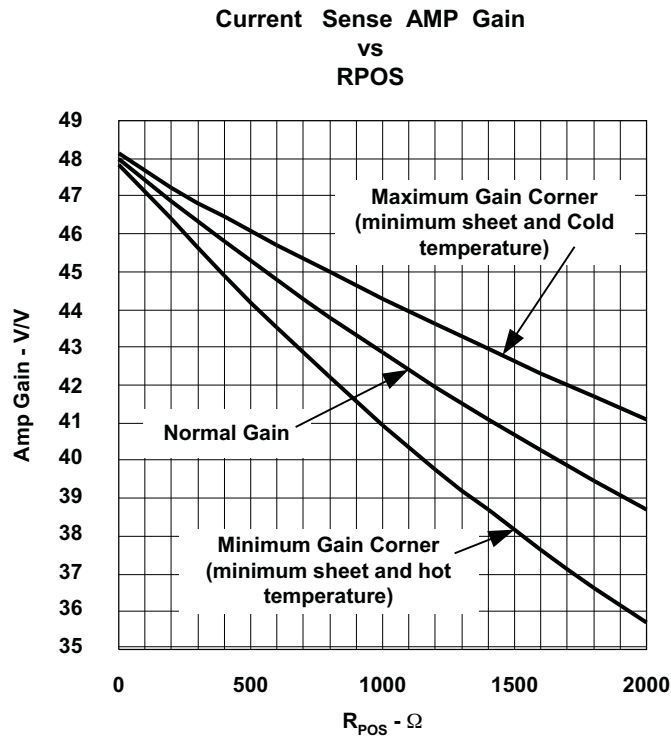

Figure 6. Current Sense Amp Gain as a Function of R_{POS}

The amp output can go up to 3.3 V, so reasonable designs limits full scale to 3.0 V. Should attenuation be necessary, use a resistive divider between AO and the control chip A/D input as shown in Figure 7.

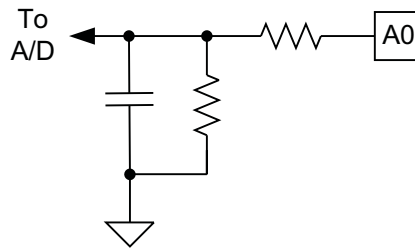

Figure 7. Attenuating and Filtering the Voltage Representation of the Average Output Current

While the current sense amplifier is useful for accurate current monitoring or controlling overload conditions, extreme overload conditions must be handled in timeframes that are generally much shorter than the A/D of a control chip can achieve. Therefore, there are two comparators on the UCD7230 to sense extreme overload and protect the driven power MOSFETs.

Extreme current overload is handled in two ways by the UCD7230. One is a comparator that monitors the voltage between POS and NEG, or effectively the output current of the converter.. The other is a comparator that monitors the voltage drop across the high-side MOSFET, or effectively the input current. Should either condition exceed a preset value, OUT1 is immediately turned off for the remainder of the cycle.

To program the current limit, a value of resistance from DLY to AGND must first be chosen to establish a blanking time during which the comparators will be blinded to switching noise. The blanking time starts with the rising edge on IN for the input comparator and from both the rising and falling edge of IN for the output comparator. Blanking time is given by:

$$t_{BLANK} (ns) \approx 5R_{DLY} (k\Omega) \quad (4)$$

where R_{DLY} is the resistor from DLY to AGND. R_{DLY} should be limited to a range of 25 k Ω to 100 k Ω .

Once R_{DLY} has been chosen, the threshold for the input comparator, i.e., the drop allowed across the high-side MOSFET, is given by:

$$V_{CS(in)} = 1.2 \times \left(\frac{R_{CS+}}{R_{DLY}} \right) \quad (5)$$

Where $V_{CS(in)}$ is the threshold of allowed voltage across the high-side MOSFET and R_{CS+} is a resistor connected from CS+ to the drain of the high-side MOSFET.

The blanking time for the output comparator is identical to the input comparator. The output comparator threshold is given by:

$$V_{CS(out)} = \frac{I_{LIM}}{10} \quad (6)$$

where $V_{CS(out)}$ is the threshold of allowed voltage between the POS and NEG pins and I_{LIM} is the voltage on the ILIM pin. Note that the ILIM is internally connected to 0.5 V through a 42 k Ω resistor. Any voltage between 0.25 V and 1.0 V can be applied to ILIM. For voltages above 1.0 V, the maximum $V_{CS(OUT)}$ threshold is clamped to 0.1 V. Possible methods for setting ILIM are shown in Figure 8.

When using the output comparator to monitor the voltage on the parallel sensing capacitor across the inductor, the same caveats apply as described for the current sense amplifier.

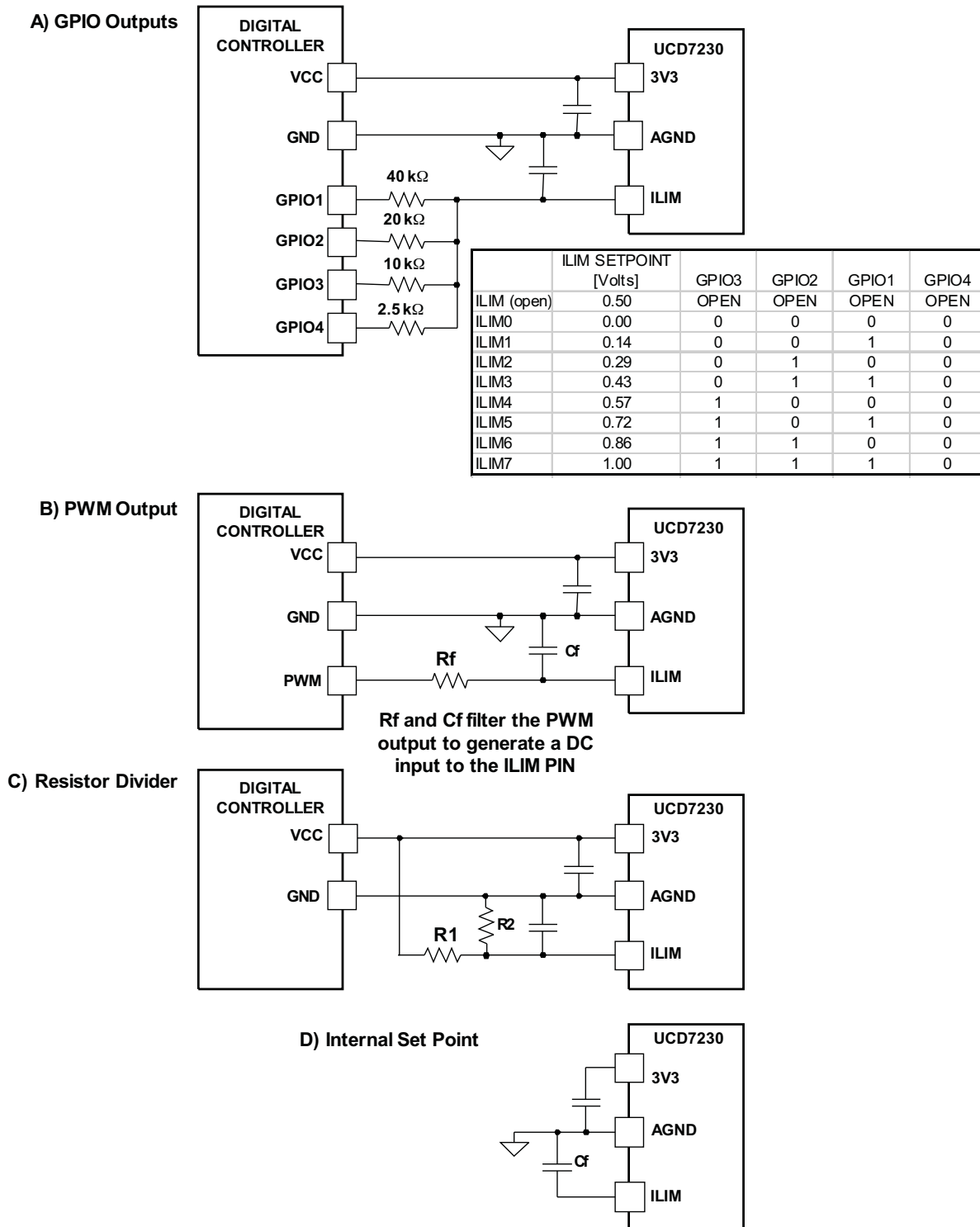

Figure 8. Setting the ILIM Voltage with: a) GPIO Outputs, b) PWM Output, c) Resistor Divider, d) Internal Set Point

If either comparator threshold is exceeded, OUT1 is immediately turned off for the remainder of the cycle and CLF is asserted true. Upon the rising edge of IN, the switches resume normal operation, but the CLF assertion is maintained. If a fault is not detected in this switching cycle, then the next rising edge of IN removes the CLF assertion. However, if one of the comparators detects a fault, then CLF assertion continues. It is the privilege of the control device to monitor CLF and decide how to handle the fault condition. In the mean while, the protection comparators protect the power MOSFET switches on a cycle-by-cycle basis. If the output-sense comparator (POS - NEG) detects continuous over-current, then the driver assumes 0% duty cycle until the current drops to a safe value. Note that when a fault condition causes OUT1 to be driven low, OUT2 behaves as if the input pulse had been terminated normally. In some fault conditions, it is advantageous to drive OUT2 low. SRE can be used to cause OUT2 to remain low at the discretion of the control chip. This can be used to achieve faster discharge of the inductor and also to fully disconnect the converter from the output voltage.

Startup Handshaking

The UCD7230 has a built-in handshaking feature to facilitate efficient start-up of the digitally controlled power supply. At start-up the CLF flag is held high until all the internal and external supply voltages of the device are within their operating range. Once the supply voltages are within acceptable limits, CLF goes low and the device will process input commands. The digital controller should monitor CLF at start-up and wait for CLF to go low before sending pwm information to the UCD7230.

Thermal Management

The usefulness of a driver is greatly affected by the drive power requirements of the load and the thermal characteristics of the device package. In order for a power driver to be used over a particular temperature range, the package must allow for the efficient removal of the heat while keeping the junction temperature within rated limits. The UCD7230 is available in PowerPAD™ HTSSOP and QFN packages to cover a range of application requirements. Both have the exposed pads to remove thermal energy from the semiconductor junction.

As illustrated in Reference [3 & 4], the PowerPAD™ packages offer a lead-frame die pad that is exposed at the base of the package. This pad is soldered to the copper on the PC board (PCB) directly underneath the device package, reducing the θ_{JA} down to 38°C/W. The PC board must be designed with thermal lands and thermal vias to complete the heat removal subsystem, as summarized in Reference [3].

Note that the PowerPAD™ is not directly connected to any leads of the package. However, it is electrically and thermally connected to the substrate which is the ground of the device. The PowerPAD™ should be connected to the quiet ground of the circuit.

REFERENCES

1. Power Supply Seminar SEM-1600 Topic 6: *A Practical Introduction to Digital Power Supply Control*, by Laszlo Balogh, Texas Instruments Literature No. SLUP224
2. Power Supply Seminar SEM-1400 Topic 2: *Design and Application Guide for High Speed MOSFET Gate Drive Circuits*, by Laszlo Balogh, Texas Instruments Literature No. SLUP133.
3. Technical Brief, *PowerPad Thermally Enhanced Package*, Texas Instruments Literature No. SLMA002
4. Application Brief, *PowerPAD™ Made Easy*, Texas Instruments Literature No. SLMA004

RELATED PRODUCTS

Table 1. RELATED PRODUCTS

PRODUCT	DESCRIPTION	FEATURES
UCD9501	Digital power controller for high performance multi-loop applications	
UCD9111	Digital power controller for power supply applications	
UCD9112	Digital power controller for power supply applications	

REVISION HISTORY

Changes from Revision C (march 2007) to Revision D	Page
• Changed Figure 1	2
• Changed Figure 2	3
• Deleted PWP CONNECTION DIAGRAM	4
• Changed HTSSOP-20 (PWP), and QFN-20 (RGW) packages are available taped and reeled. Add R suffix to device type (e.g. UCD7230PWPR) to order quantities of 2,000 devices per reel for the PWP package and 1,000 devices per reel for the RGW packages.	4
• Added QFN-20 (RGW) package is available taped and reeled. Add T suffix to device type (e.g. UCD7230RGW) to order quantities of 1,000 devices per reel.	4

TAPE AND REEL INFORMATION

QUADRANT ASSIGNMENTS FOR PIN 1 ORIENTATION IN TAPE

*All dimensions are nominal

Device	Package Type	Package Drawing	Pins	SPQ	Reel Diameter (mm)	Reel Width W1 (mm)	A0 (mm)	B0 (mm)	K0 (mm)	P1 (mm)	W (mm)	Pin1 Quadrant
UCD7230PWPR	HTSSOP	PWP	20	2000	330.0	16.4	6.95	7.1	1.6	8.0	16.0	Q1
UCD7230RGWR	VQFN	RGW	20	3000	330.0	12.4	5.25	5.25	1.1	8.0	12.0	Q2
UCD7230RGWR	VQFN	RGW	20	3000	330.0	12.4	5.3	5.3	1.5	8.0	12.0	Q2
UCD7230RGWT	VQFN	RGW	20	250	180.0	12.4	5.3	5.3	1.5	8.0	12.0	Q2
UCD7230RGWT	VQFN	RGW	20	250	180.0	12.4	5.25	5.25	1.1	8.0	12.0	Q2

TAPE AND REEL BOX DIMENSIONS



*All dimensions are nominal

Device	Package Type	Package Drawing	Pins	SPQ	Length (mm)	Width (mm)	Height (mm)
UCD7230PWPR	HTSSOP	PWP	20	2000	367.0	367.0	38.0
UCD7230RGWR	VQFN	RGW	20	3000	370.0	355.0	55.0
UCD7230RGWR	VQFN	RGW	20	3000	367.0	367.0	35.0
UCD7230RGWT	VQFN	RGW	20	250	210.0	185.0	35.0
UCD7230RGWT	VQFN	RGW	20	250	195.0	200.0	45.0

MECHANICAL DATA

PWP (R-PDSO-G20)

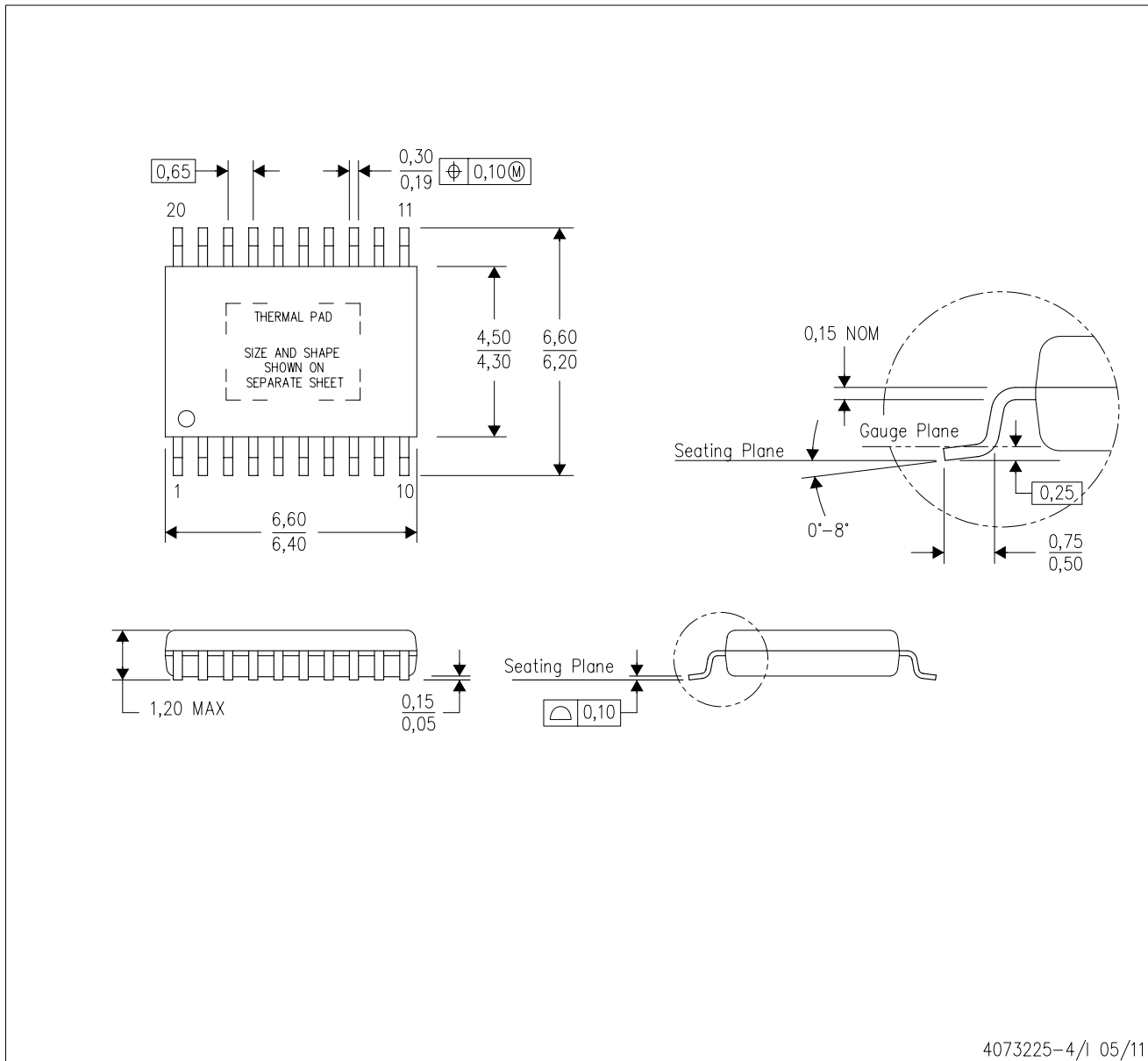
PowerPAD™ PLASTIC SMALL OUTLINE



4073225-4/1 05/11

- NOTES:
- All linear dimensions are in millimeters.
 - This drawing is subject to change without notice.
 - Body dimensions do not include mold flash or protrusions. Mold flash and protrusion shall not exceed 0.15 per side.
 - This package is designed to be soldered to a thermal pad on the board. Refer to Technical Brief, PowerPad Thermally Enhanced Package, Texas Instruments Literature No. SLMA002 for information regarding recommended board layout. This document is available at www.ti.com <<http://www.ti.com>>.
 - See the additional figure in the Product Data Sheet for details regarding the exposed thermal pad features and dimensions.
 - Falls within JEDEC MO-153

PowerPAD is a trademark of Texas Instruments.

THERMAL PAD MECHANICAL DATA

PWP (R-PDSO-G20) PowerPAD™ SMALL PLASTIC OUTLINE

THERMAL INFORMATION

This PowerPAD™ package incorporates an exposed thermal pad that is designed to be attached to a printed circuit board (PCB). The thermal pad must be soldered directly to the PCB. After soldering, the PCB can be used as a heatsink. In addition, through the use of thermal vias, the thermal pad can be attached directly to the appropriate copper plane shown in the electrical schematic for the device, or alternatively, can be attached to a special heatsink structure designed into the PCB. This design optimizes the heat transfer from the integrated circuit (IC).

For additional information on the PowerPAD package and how to take advantage of its heat dissipating abilities, refer to Technical Brief, PowerPAD Thermally Enhanced Package, Texas Instruments Literature No. SLMA002 and Application Brief, PowerPAD Made Easy, Texas Instruments Literature No. SLMA004. Both documents are available at www.ti.com.

The exposed thermal pad dimensions for this package are shown in the following illustration.

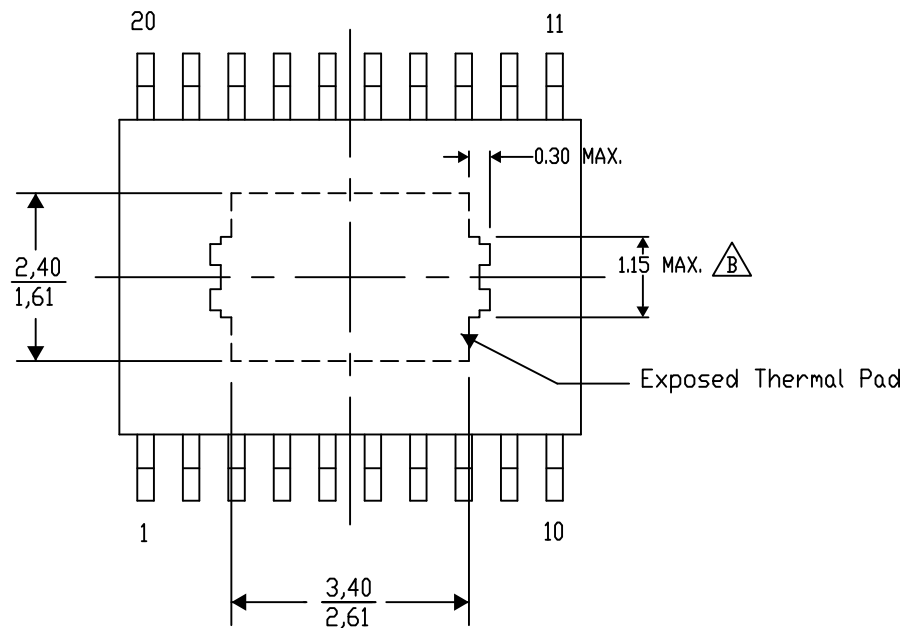

4206332-15/AC 07/12

NOTE: A. All linear dimensions are in millimeters

 Exposed tie strap features may not be present.

PowerPAD is a trademark of Texas Instruments

PWP (R-PDSO-G20)

PowerPAD™ PLASTIC SMALL OUTLINE

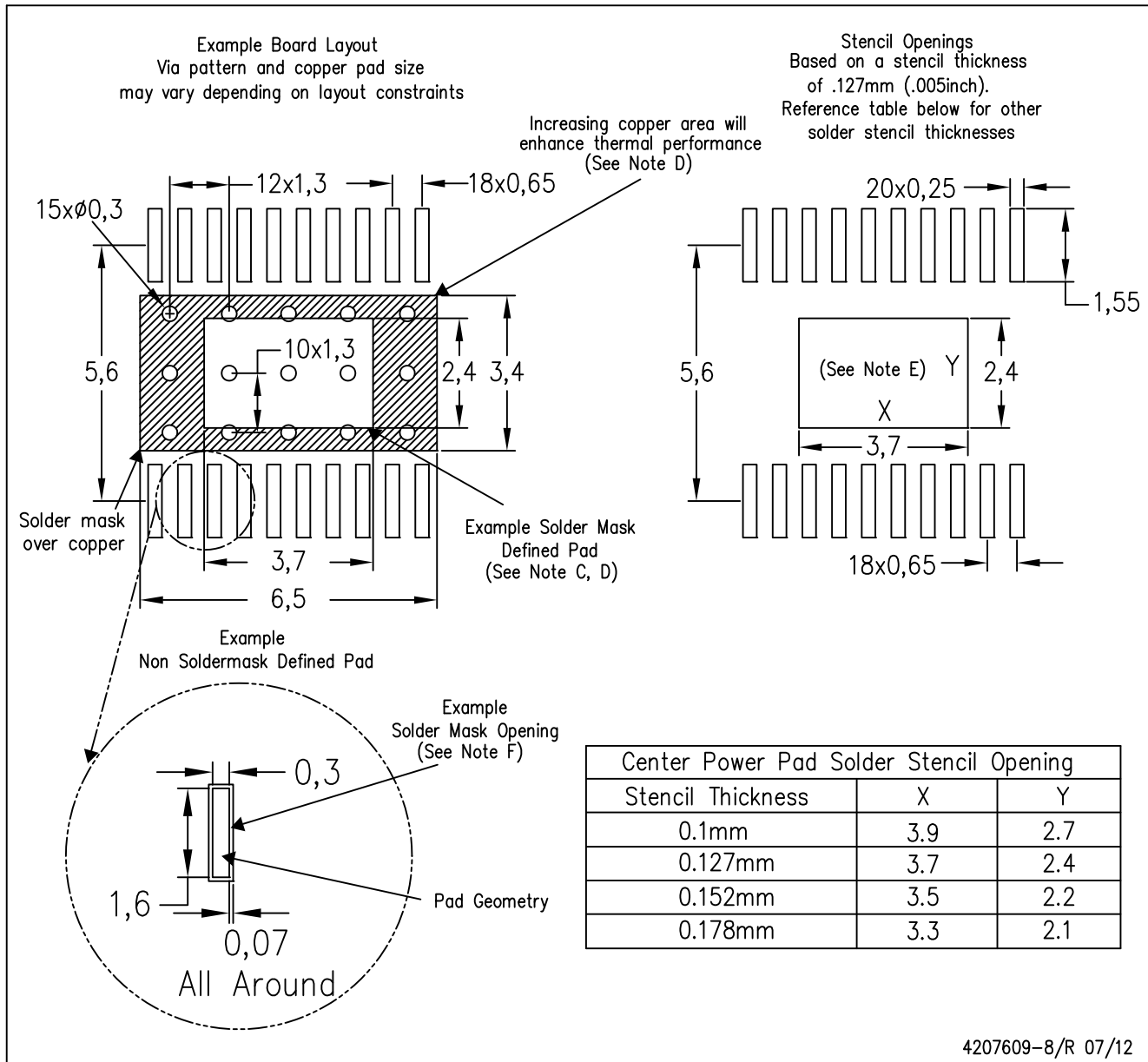

- NOTES:
- A. All linear dimensions are in millimeters.
 - B. This drawing is subject to change without notice.
 - C. Customers should place a note on the circuit board fabrication drawing not to alter the center solder mask defined pad.
 - D. This package is designed to be soldered to a thermal pad on the board. Refer to Technical Brief, PowerPad Thermally Enhanced Package, Texas Instruments Literature No. SLMA002, SLMA004, and also the Product Data Sheets for specific thermal information, via requirements, and recommended board layout. These documents are available at www.ti.com <<http://www.ti.com>>. Publication IPC-7351 is recommended for alternate designs.
 - E. Laser cutting apertures with trapezoidal walls and also rounding corners will offer better paste release. Customers should contact their board assembly site for stencil design recommendations. Example stencil design based on a 50% volumetric metal load solder paste. Refer to IPC-7525 for other stencil recommendations.
 - F. Customers should contact their board fabrication site for solder mask tolerances between and around signal pads.

MECHANICAL DATA

RGW (S-PVQFN-N20)

PLASTIC QUAD FLATPACK NO-LEAD

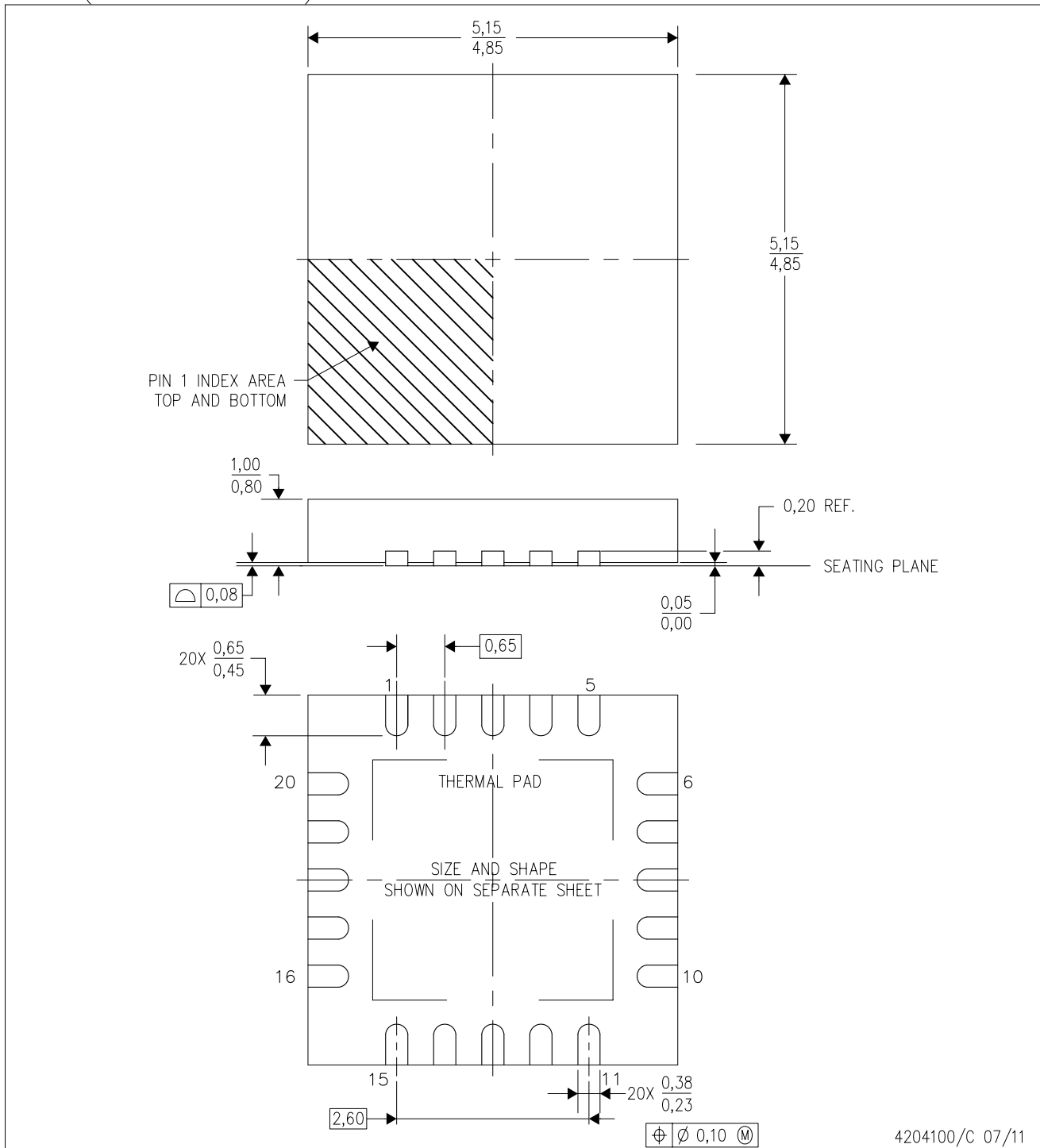

- NOTES:
- All linear dimensions are in millimeters. Dimensioning and tolerancing per ASME Y14.5-1994.
 - This drawing is subject to change without notice.
 - Quad Flat pack, No-leads (QFN) package configuration
 - The package thermal pad must be soldered to the board for thermal and mechanical performance.
 - See the additional figure in the Product Data Sheet for details regarding the exposed thermal pad features and dimensions.
 - Falls within JEDEC MO-220.

THERMAL PAD MECHANICAL DATA

RGW (S-PVQFN-N20)

PLASTIC QUAD FLATPACK NO-LEAD

THERMAL INFORMATION

This package incorporates an exposed thermal pad that is designed to be attached directly to an external heatsink. The thermal pad must be soldered directly to the printed circuit board (PCB). After soldering, the PCB can be used as a heatsink. In addition, through the use of thermal vias, the thermal pad can be attached directly to the appropriate copper plane shown in the electrical schematic for the device, or alternatively, can be attached to a special heatsink structure designed into the PCB. This design optimizes the heat transfer from the integrated circuit (IC).

For information on the Quad Flatpack No-Lead (QFN) package and its advantages, refer to Application Report, QFN/SON PCB Attachment, Texas Instruments Literature No. SLUA271. This document is available at www.ti.com.

The exposed thermal pad dimensions for this package are shown in the following illustration.

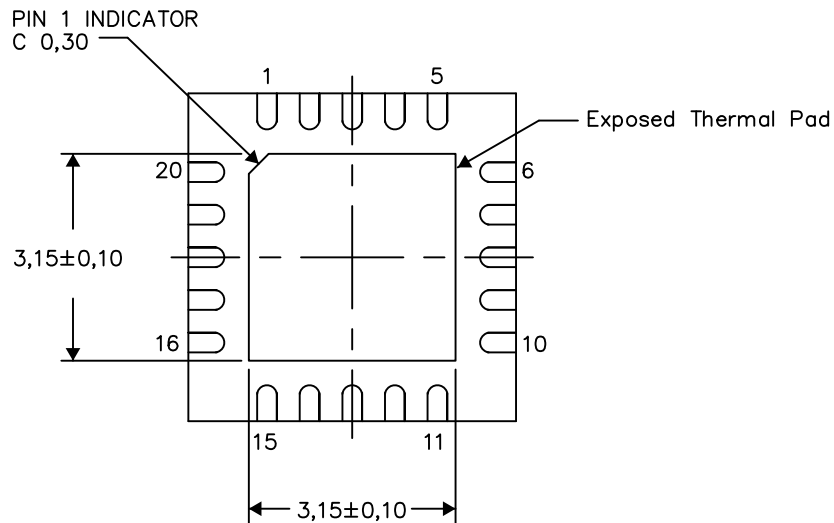

Exposed Thermal Pad Dimensions

4206352-2/K 12/12

NOTE: All linear dimensions are in millimeters

RGW (S-PVQFN-N20)

PLASTIC QUAD FLATPACK NO-LEAD

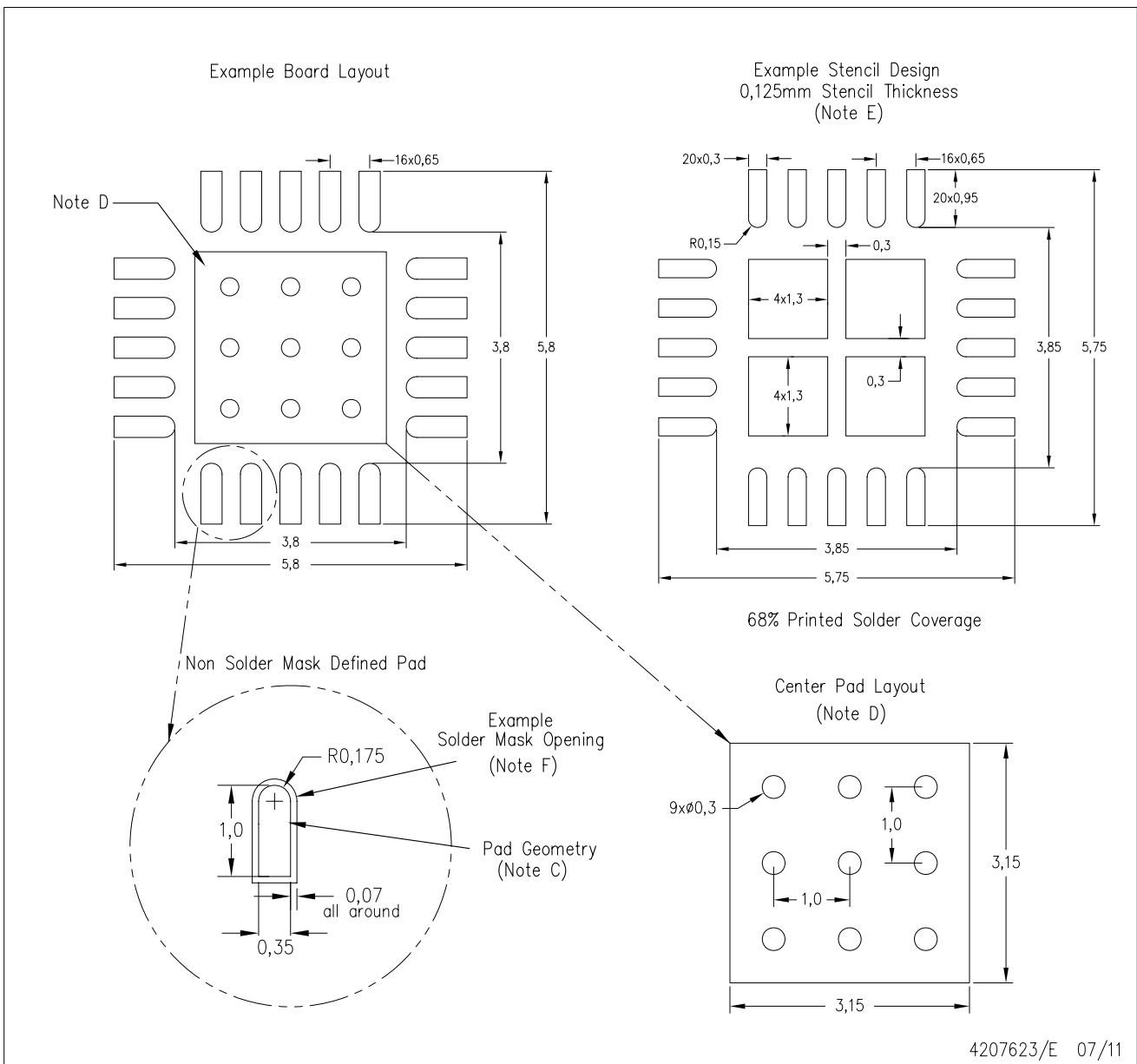

- NOTES:
- All linear dimensions are in millimeters.
 - This drawing is subject to change without notice.
 - Publication IPC-7351 is recommended for alternate designs.
 - This package is designed to be soldered to a thermal pad on the board. Refer to Application Note, QFN Packages, Texas Instruments Literature No. SLUA271, and also the Product Data Sheets for specific thermal information, via requirements, and recommended board layout. These documents are available at www.ti.com <<http://www.ti.com>>.
 - Laser cutting apertures with trapezoidal walls and also rounding corners will offer better paste release. Customers should contact their board assembly site for stencil design recommendations. Refer to IPC 7525 for stencil design considerations.
 - Customers should contact their board fabrication site for solder mask tolerances.

IMPORTANT NOTICE

Texas Instruments Incorporated and its subsidiaries (TI) reserve the right to make corrections, enhancements, improvements and other changes to its semiconductor products and services per JESD46, latest issue, and to discontinue any product or service per JESD48, latest issue. Buyers should obtain the latest relevant information before placing orders and should verify that such information is current and complete. All semiconductor products (also referred to herein as "components") are sold subject to TI's terms and conditions of sale supplied at the time of order acknowledgment.

TI warrants performance of its components to the specifications applicable at the time of sale, in accordance with the warranty in TI's terms and conditions of sale of semiconductor products. Testing and other quality control techniques are used to the extent TI deems necessary to support this warranty. Except where mandated by applicable law, testing of all parameters of each component is not necessarily performed.

TI assumes no liability for applications assistance or the design of Buyers' products. Buyers are responsible for their products and applications using TI components. To minimize the risks associated with Buyers' products and applications, Buyers should provide adequate design and operating safeguards.

TI does not warrant or represent that any license, either express or implied, is granted under any patent right, copyright, mask work right, or other intellectual property right relating to any combination, machine, or process in which TI components or services are used. Information published by TI regarding third-party products or services does not constitute a license to use such products or services or a warranty or endorsement thereof. Use of such information may require a license from a third party under the patents or other intellectual property of the third party, or a license from TI under the patents or other intellectual property of TI.

Reproduction of significant portions of TI information in TI data books or data sheets is permissible only if reproduction is without alteration and is accompanied by all associated warranties, conditions, limitations, and notices. TI is not responsible or liable for such altered documentation. Information of third parties may be subject to additional restrictions.

Resale of TI components or services with statements different from or beyond the parameters stated by TI for that component or service voids all express and any implied warranties for the associated TI component or service and is an unfair and deceptive business practice. TI is not responsible or liable for any such statements.

Buyer acknowledges and agrees that it is solely responsible for compliance with all legal, regulatory and safety-related requirements concerning its products, and any use of TI components in its applications, notwithstanding any applications-related information or support that may be provided by TI. Buyer represents and agrees that it has all the necessary expertise to create and implement safeguards which anticipate dangerous consequences of failures, monitor failures and their consequences, lessen the likelihood of failures that might cause harm and take appropriate remedial actions. Buyer will fully indemnify TI and its representatives against any damages arising out of the use of any TI components in safety-critical applications.

In some cases, TI components may be promoted specifically to facilitate safety-related applications. With such components, TI's goal is to help enable customers to design and create their own end-product solutions that meet applicable functional safety standards and requirements. Nonetheless, such components are subject to these terms.

No TI components are authorized for use in FDA Class III (or similar life-critical medical equipment) unless authorized officers of the parties have executed a special agreement specifically governing such use.

Only those TI components which TI has specifically designated as military grade or "enhanced plastic" are designed and intended for use in military/aerospace applications or environments. Buyer acknowledges and agrees that any military or aerospace use of TI components which have **not** been so designated is solely at the Buyer's risk, and that Buyer is solely responsible for compliance with all legal and regulatory requirements in connection with such use.

TI has specifically designated certain components as meeting ISO/TS16949 requirements, mainly for automotive use. In any case of use of non-designated products, TI will not be responsible for any failure to meet ISO/TS16949.

Products

Audio	www.ti.com/audio
Amplifiers	amplifier.ti.com
Data Converters	dataconverter.ti.com
DLP® Products	www.dlp.com
DSP	dsp.ti.com
Clocks and Timers	www.ti.com/clocks
Interface	interface.ti.com
Logic	logic.ti.com
Power Mgmt	power.ti.com
Microcontrollers	microcontroller.ti.com
RFID	www.ti-rfid.com
OMAP Applications Processors	www.ti.com/omap
Wireless Connectivity	www.ti.com/wirelessconnectivity

Applications

Automotive and Transportation	www.ti.com/automotive
Communications and Telecom	www.ti.com/communications
Computers and Peripherals	www.ti.com/computers
Consumer Electronics	www.ti.com/consumer-apps
Energy and Lighting	www.ti.com/energy
Industrial	www.ti.com/industrial
Medical	www.ti.com/medical
Security	www.ti.com/security
Space, Avionics and Defense	www.ti.com/space-avionics-defense
Video and Imaging	www.ti.com/video

TI E2E Community

e2e.ti.com