

RAD-TOLERANT CLASS-V, SWITCHED MODE CONTROLLER FOR DC MOTOR DRIVE

Check for Samples: [UC1637-SP](#)

FEATURES

- QML-V Qualified, SMD 5962-89957
- Rad Tolerant: 30 kRad(Si) TID ⁽¹⁾
 - TID Dose Rate = 10 mRad/sec
- Single or Dual Supply Operation
- $\pm 2.5\text{-V}$ to $\pm 20\text{-V}$ Input Supply Range
- $\pm 5\%$ Initial Oscillator Accuracy; $\pm 10\%$ Over Temperature
- Pulse-by-Pulse Current Limiting
- Under-Voltage Lockout
- Shutdown Input with Temperature Compensated 2.5-V Threshold
- Uncommitted PWM Comparators for Design

(1) Radiation tolerance is a typical value based upon initial device qualification. Radiation Lot Acceptance Testing is available - contact factory for details.

Flexibility

- Dual 100-mA Source/Sink Output Drivers

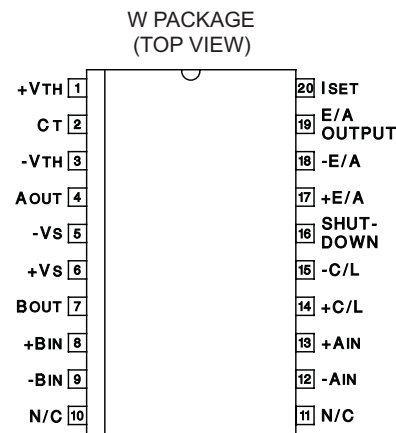

DESCRIPTION

The UC1637 is a pulse width modulator circuit intended to be used for a variety of PWM motor drive and amplifier applications requiring either uni-directional or bi-directional drive circuits. When used to replace conventional drivers, this circuit can increase efficiency and reduce component costs for many applications. All necessary circuitry is included to generate an analog error signal and modulate two bi-directional pulse train outputs in proportion to the error signal magnitude and polarity.

This monolithic device contains a sawtooth oscillator, error amplifier, and two PWM comparators with $\pm 100\text{-mA}$ output stages as standard features. Protection circuitry includes under-voltage lockout, pulse-by-pulse current limiting, and a shutdown port with a 2.5-V temperature compensated threshold.

The UC1637 is characterized for operation over the full space temperature range of -55°C to 125°C .

ORDERING INFORMATION

T_A	PACKAGE	ORDERABLE PART NUMBER	TOP-SIDE MARKING
-55°C to 125°C	CFP-20	5962-8995701VSA	UC1637W-SP



Please be aware that an important notice concerning availability, standard warranty, and use in critical applications of Texas Instruments semiconductor products and disclaimers thereto appears at the end of this data sheet.

FUNCTIONAL BLOCK DIAGRAM

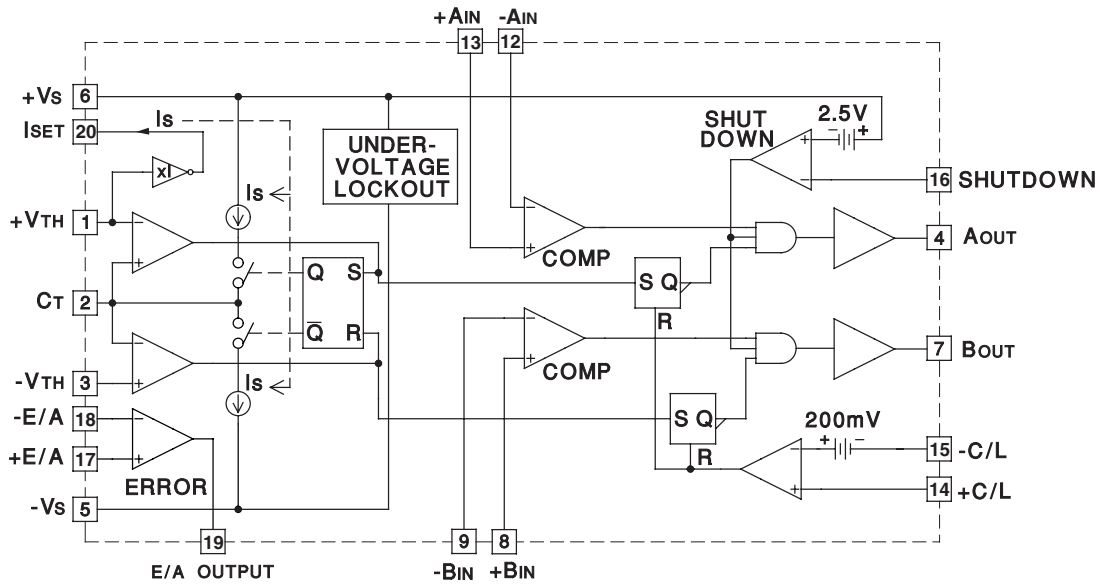

Note: Fault latches are reset dominant.

ABSOLUTE MAXIMUM RATINGS^{(1) (2)}

over operating free-air temperature range (unless otherwise noted)

		VALUE	UNIT
V_S	Supply voltage	± 20	V
I_O	Output current, source/sink (A_{OUT} , B_{OUT})	Peak	500
		Steady-state	100
Analog inputs ($+V_{TH}$, C_T , $-V_{TH}$, $+B_{IN}$, $-B_{IN}$, $-A_{IN}$, $+A_{IN}$, $+C/L$, $-C/L$, SHUTDOWN, $+E/A$, $-E/A$)		$\pm V_S$	V
Error amplifier output current (E/A_{OUTPUT})		± 20	mA
Oscillator charging current (I_{SET})		-2	mA
T_J	Junction temperature	150	$^{\circ}C$
T_{stg}	Storage temperature range	-65 to 150	$^{\circ}C$
	Lead temperature (soldering, 10 seconds)	300	$^{\circ}C$

- (1) Stresses beyond those listed under "absolute maximum ratings" may cause permanent damage to the device. These are stress ratings only. Exposure to absolute-maximum-rated conditions for extended periods may affect device reliability.
- (2) Currents are positive into, negative out of the specified terminal.

ELECTRICAL CHARACTERISTICS

over operating free-air temperature range, $V_S = 15\text{ V}$, $-V_S = -15\text{ V}$, $+V_{TH} = 5\text{ V}$, $-V_{TH} = -5\text{ V}$, $R_T = 16.7\text{ k}\Omega$, $C_T = 1500\text{ pF}$, $T_A = -55^\circ\text{C}$ to $125^\circ\text{C} = T_J$ (unless otherwise noted).

PARAMETER		TEST CONDITIONS	MIN	TYP	MAX	UNIT
OSCILLATOR						
Initial accuracy ⁽¹⁾		$T_J = 25^\circ\text{C}$	9.4	10	10.6	kHz
		$T_J = -55^\circ\text{C}$ to 125°C	9.2		10.8	
Voltage stability		$V_S = \pm 5\text{ V}$ to $\pm 20\text{ V}$, $+V_{TH} = 3\text{ V}$, $-V_{TH} = -3\text{ V}$		5	7	%
Temperature stability		Over operating range		0.5		%
Input bias current	$+V_{TH}$	$C_T = 6\text{ V}$	-10	0.1	10	μA
	$-V_{TH}$	$C_T = 0\text{ V}$	-10	-0.5		
Input range ($+V_{TH}$, $-V_{TH}$)			$-V_S+2$		$+V_S-2$	V
ERROR AMPLIFIER						
Input offset voltage		$V_{CM} = 0\text{ V}$		1.5	± 5	mV
Input bias current		$V_{CM} = 0\text{ V}$		0.5	5	μA
Input offset current		$V_{CM} = 0\text{ V}$		0.1	± 1	μA
Common mode range		$V_S = \pm 2.5\text{ V}$ to $\pm 20\text{ V}$	$-V_S+2$		$+V_S$	V
Open loop voltage gain		$R_L = 10\text{ k}$	75	100		dB
Slew rate				15		V/ μs
Unity gain bandwidth				1		MHz
CMRR		Over common mode range	75	100		dB
PSRR		$V_S = \pm 2.5\text{ V}$ to $\pm 20\text{ V}$	75	110		dB
Output sink current		$E/A_{\text{OUTPUT}} = 0\text{ V}$	20	50		mA
Output source current		$E/A_{\text{OUTPUT}} = 0\text{ V}$		-11	-5	mA
High level output voltage			13	13.6		V
Low level output voltage				-14.8	-13	V
PWM COMPARATORS						
Input offset voltage		$V_{CM} = 0\text{ V}$	-10	20	50	mV
Input bias current		$V_{CM} = 0\text{ V}$		2	10	μA
Input Hysteresis		$V_{CM} = 0\text{ V}$		10	30	mV
Common mode range		$V_S = \pm 5\text{ V}$ to $\pm 20\text{ V}$	$-V_S+1$		$+V_S-2$	V
CURRENT LIMIT						
Input offset voltage		$V_{CM} = 0\text{ V}$, $T_J = 25^\circ\text{C}$	190	200	210	mV
		$V_{CM} = 0\text{ V}$, $T_J = -55^\circ\text{C}$ to 125°C	160		370	
Input offset voltage T.C.				-0.2		mV/ $^\circ\text{C}$
Input bias current			-10	-1.5		μA
Common mode range		$V_S = \pm 2.5\text{ V}$ to $\pm 20\text{ V}$	$-V_S$		$+V_S-3$	V
SHUTDOWN						
Shutdown threshold ⁽²⁾			-2.7	-2.5	-2.3	V
Hysteresis				40		mV
Input bias current		SHUTDOWN = $+V_S$ to $-V_S$	-10	-0.5		μA
UNDER-VOLTAGE LOCKOUT						
Start threshold ⁽³⁾				4.15	5	V
Hysteresis			75	250	500	mV
TOTAL STANDBY CURRENT						
Supply current				8.5	15	mA

(1) R_T and C_T referenced to ground.

(2) Parameter measured with respect to $+V_S$ (Pin 6).

(3) Parameter measured at $+V_S$ (Pin 6) with respect to $-V_S$ (Pin 5).

ELECTRICAL CHARACTERISTICS (continued)

over operating free-air temperature range, $V_S = 15\text{ V}$, $-V_S = -15\text{ V}$, $+V_{TH} = 5\text{ V}$, $-V_{TH} = -5\text{ V}$, $R_T = 16.7\text{ k}\Omega$, $C_T = 1500\text{ pF}$, $T_A = -55^\circ\text{C}$ to $125^\circ\text{C} = T_J$ (unless otherwise noted).

PARAMETER	TEST CONDITIONS	MIN	TYP	MAX	UNIT
OUTPUT SECTION					
Output low level	$I_{SINK} = 20\text{ mA}$		-14.9	-13	V
	$I_{SINK} = 100\text{ mA}$		-14.5	-13	
Output high level	$I_{SOURCE} = 20\text{ mA}$	13	13.5		V
	$I_{SOURCE} = 100\text{ mA}$	12	13.5		
Rise time	$C_L = 1\text{ nF}$, $T_J = 25^\circ\text{C}^{(4)}$		100	600	ns
Fall time	$C_L = 1\text{ nF}$, $T_J = 25^\circ\text{C}^{(4)}$		100	300	ns

(4) Parameters ensured by design and/or characterization, if not production tested.

FUNCTIONAL DESCRIPTION

The following is a description of each of the functional blocks shown in the Functional Block Diagram.

Oscillator

The oscillator consists of two comparators, a charging and discharging current source, a current source set terminal, I_{SET} , and a flip-flop. The upper and lower threshold of the oscillator waveform is set externally by applying a voltage at pins $+V_{TH}$ and $-V_{TH}$ respectively. The $+V_{TH}$ terminal voltage is buffered internally and also applied to the ISET terminal to develop the capacitor charging current through R_T . If R_T is referenced to $-V_S$ as shown in Figure 1, both the threshold voltage and charging current will vary proportionally to the supply differential, and the oscillator frequency will remain constant. The triangle waveform oscillator's frequency and voltage amplitude are determined by the external components using the formulas given in Figure 1.

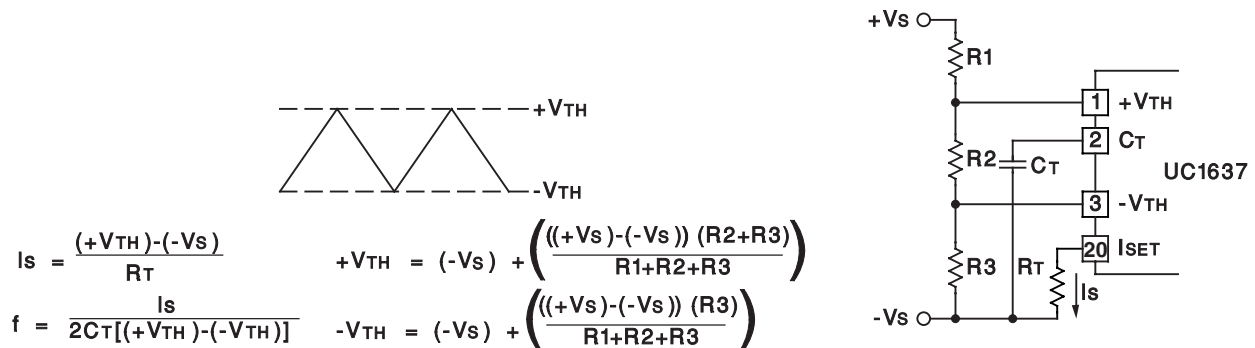

Figure 1. Oscillator Setup

PWM Comparators

Two comparators are provided to perform pulse width modulation for each of the output drivers. Inputs are uncommitted to allow maximum flexibility. The pulse width of the outputs A and B is a function of the sign and amplitude of the error signal. A negative signal at -AIN and +BIN will lengthen the high state of output A and shorten the high state of output B. Likewise, a positive error signal reverses the procedure. Typically, the oscillator waveform is compared against the summation of the error signal and the level set on -BIN and +AIN.

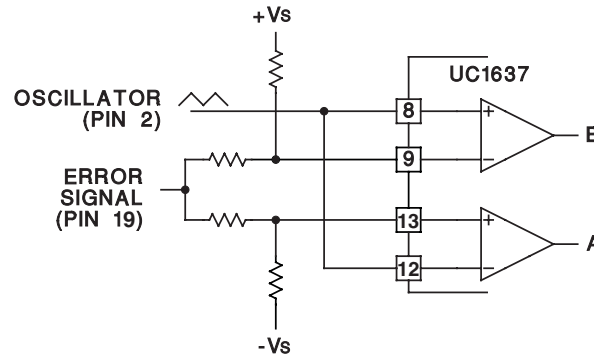

Figure 2. Comparator Biasing

MODULATION SCHEMES

Case A Zero Deadtime (Equal voltage on -BIN and +AIN)

In this configuration, maximum holding torque or stiffness and position accuracy is achieved. However, the power input into the motor is increased. [Figure 3 \(A\)](#) shows this configuration.

Case B Small Deadtime (Voltage on -BIN > +AIN)

A small differential voltage between -BIN and +AIN provides the necessary time delay to reduce the chances of momentary short circuit in the output stage during transitions, especially where power-amplifiers are used. Refer to [Figure 3 \(B\)](#).

Case C Increased Deadtime and Deadband Mode (Voltage on -BIN > +AIN)

With the reduction of stiffness and position accuracy, the power input into the motor around the null point of the servo loop can be reduced or eliminated by widening the window of the comparator circuit to a degree of acceptance. Where position accuracy and mechanical stiffness is unimportant, deadband operation can be used. This is shown in [Figure 3 \(C\)](#).

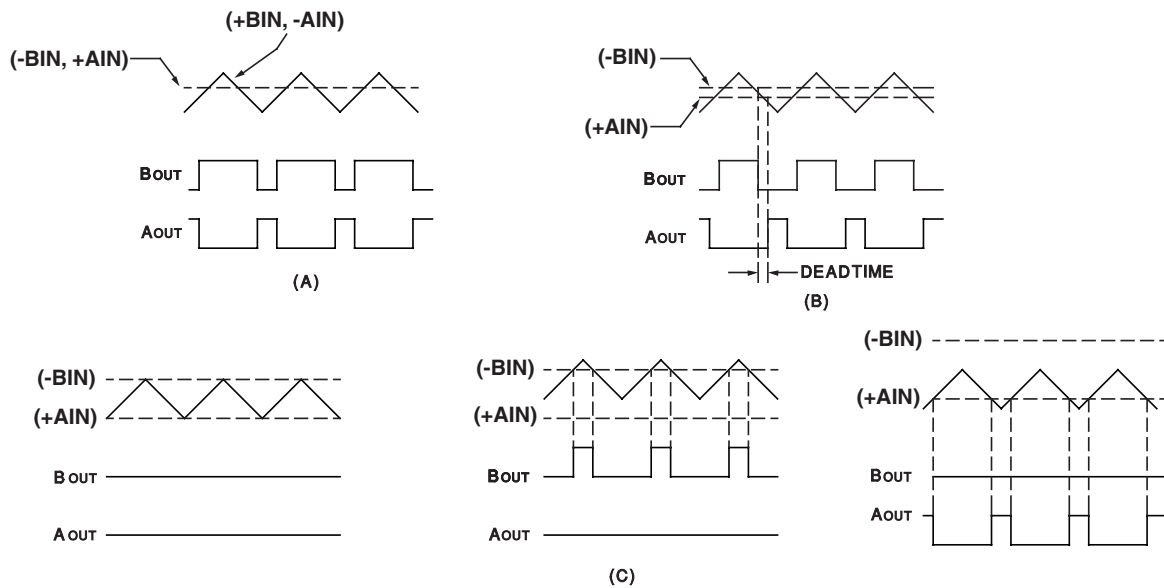

Figure 3. Modulation Schemes Showing (A) Zero Deadtime, (B) Deadtime and (C) Deadband Configurations

Output Drivers

Each output driver is capable of both sourcing and sinking 100 mA steady state and up to 500 mA on a pulsed basis for rapid switching of either POWERFET or bipolar transistors. Output levels are typically $-V_S+0.2$ V at 50 mA low level and $+V_S-2$ V at 50 mA high level.

Error Amplifier

The error amplifier consists of a high slew rate (15 V/ μ s) op-amp with a typical 1-MHz bandwidth and low output impedance. Depending on the $\pm V_S$ supply voltage, the common mode range and the voltage output swing is within 2 V of the V_S supply.

Under-Voltage Lockout

An under-voltage lockout circuit holds the outputs in the low state until a minimum of 4 V is reached. At this point, all internal circuitry is functional and the output drivers are enabled. If external circuitry requires a higher starting voltage, an over-riding voltage can be programmed through the shutdown terminal as shown in [Figure 4](#).

Shutdown Comparator

The shutdown terminal may be used for implementing various shutdown and protection schemes. By pulling the terminal more than 2.5 V below V_{IN} , the output drivers will be enabled. This can be realized using an open collector gate or NPN transistor biased to either ground or the negative supply. Since the threshold is temperature stabilized, the comparator can be used as an accurate low voltage lockout ([Figure 4](#)) and/or delayed start as in [Figure 5](#). In the shutdown mode the outputs are held in the low state.

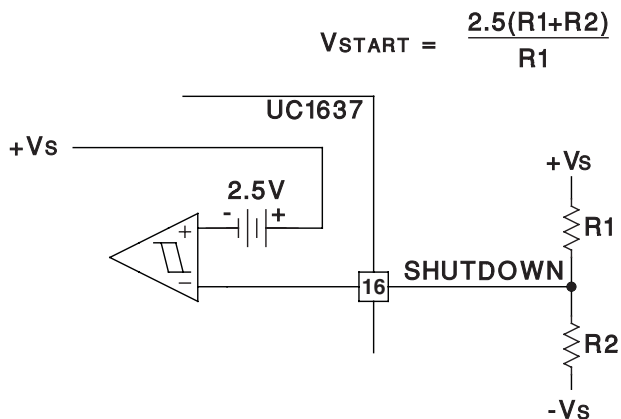

Figure 4. External Under-Voltage Lockout

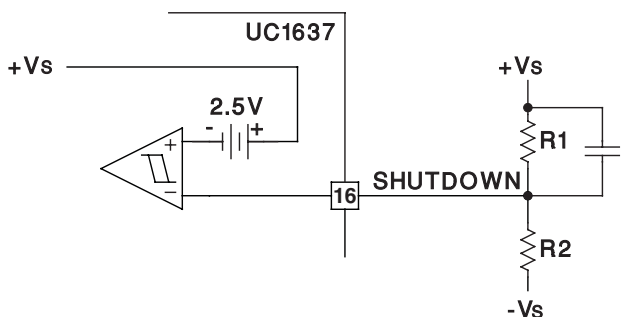

Figure 5. Delayed Start-up

Current Limit

A latched current limit amplifier with an internal 200-mV offset is provided to allow pulse-by-pulse current limiting. Differential inputs will accept common mode signals from $-V_S$ to within 3 V of the $+V_S$ supply while providing excellent noise rejection. Figure 6 shows a typical current sense circuit.

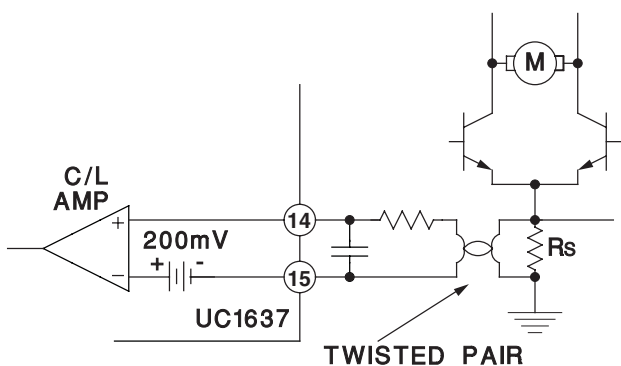

Figure 6. Current Limit Sensing

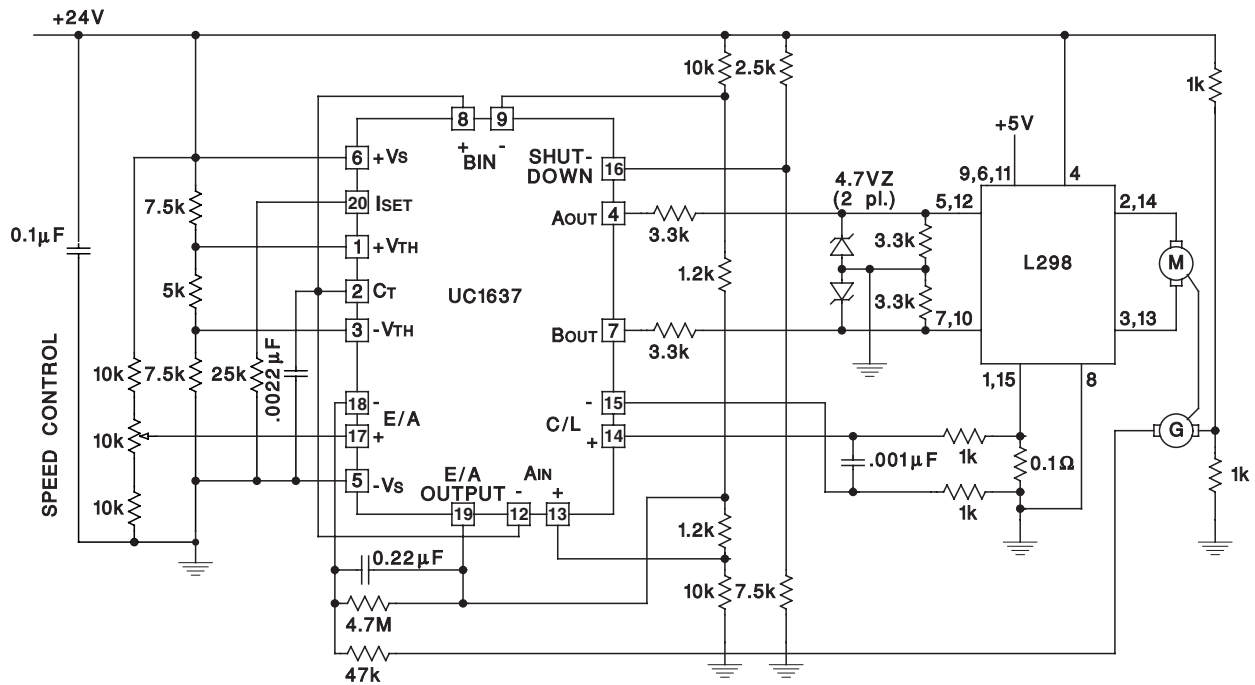

Figure 7. Bi-Directional Motor Drive With Speed Control Power-Amplifier

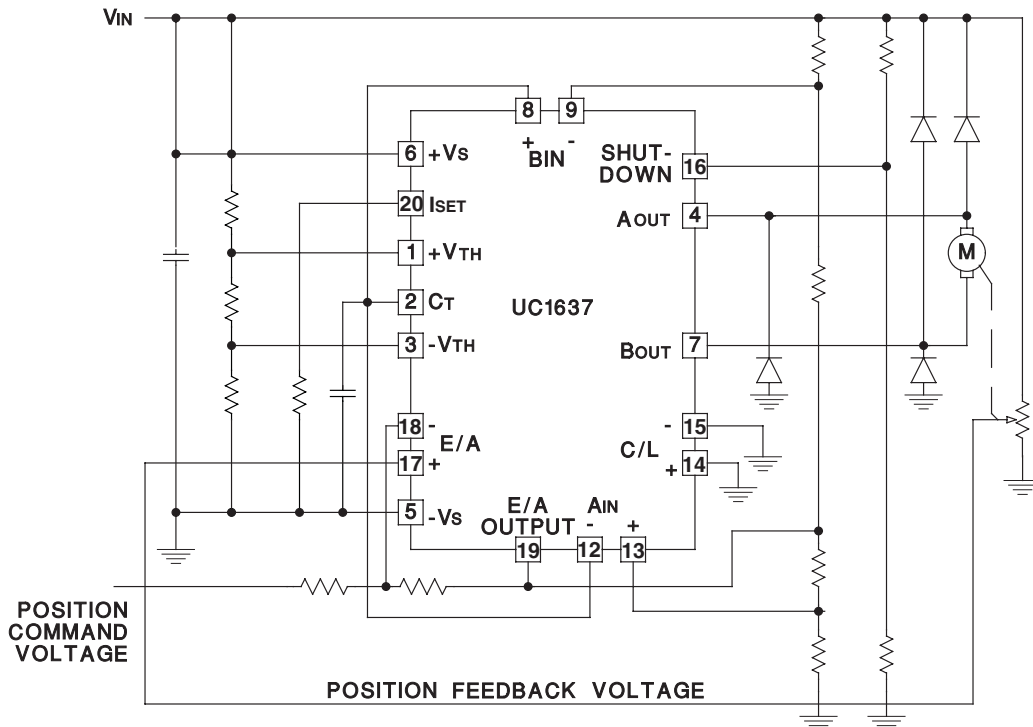

Figure 8. Single Supply Position Servo Motor Drive

PACKAGING INFORMATION

Orderable Device	Status ⁽¹⁾	Package Type	Package Drawing	Pins	Package Qty	Eco Plan ⁽²⁾	Lead/ Ball Finish	MSL Peak Temp ⁽³⁾	Samples (Requires Login)
5962-8995701VSA	ACTIVE	CFP	W	20	1	TBD	Call TI	N / A for Pkg Type	

⁽¹⁾ The marketing status values are defined as follows:

ACTIVE: Product device recommended for new designs.

LIFEBUY: TI has announced that the device will be discontinued, and a lifetime-buy period is in effect.

NRND: Not recommended for new designs. Device is in production to support existing customers, but TI does not recommend using this part in a new design.

PREVIEW: Device has been announced but is not in production. Samples may or may not be available.

OBSELETE: TI has discontinued the production of the device.

⁽²⁾ Eco Plan - The planned eco-friendly classification: Pb-Free (RoHS), Pb-Free (RoHS Exempt), or Green (RoHS & no Sb/Br) - please check <http://www.ti.com/productcontent> for the latest availability information and additional product content details.

TBD: The Pb-Free/Green conversion plan has not been defined.

Pb-Free (RoHS): TI's terms "Lead-Free" or "Pb-Free" mean semiconductor products that are compatible with the current RoHS requirements for all 6 substances, including the requirement that lead not exceed 0.1% by weight in homogeneous materials. Where designed to be soldered at high temperatures, TI Pb-Free products are suitable for use in specified lead-free processes.

Pb-Free (RoHS Exempt): This component has a RoHS exemption for either 1) lead-based flip-chip solder bumps used between the die and package, or 2) lead-based die adhesive used between the die and leadframe. The component is otherwise considered Pb-Free (RoHS compatible) as defined above.

Green (RoHS & no Sb/Br): TI defines "Green" to mean Pb-Free (RoHS compatible), and free of Bromine (Br) and Antimony (Sb) based flame retardants (Br or Sb do not exceed 0.1% by weight in homogeneous material)

⁽³⁾ MSL, Peak Temp. -- The Moisture Sensitivity Level rating according to the JEDEC industry standard classifications, and peak solder temperature.

Important Information and Disclaimer: The information provided on this page represents TI's knowledge and belief as of the date that it is provided. TI bases its knowledge and belief on information provided by third parties, and makes no representation or warranty as to the accuracy of such information. Efforts are underway to better integrate information from third parties. TI has taken and continues to take reasonable steps to provide representative and accurate information but may not have conducted destructive testing or chemical analysis on incoming materials and chemicals. TI and TI suppliers consider certain information to be proprietary, and thus CAS numbers and other limited information may not be available for release.

In no event shall TI's liability arising out of such information exceed the total purchase price of the TI part(s) at issue in this document sold by TI to Customer on an annual basis.

OTHER QUALIFIED VERSIONS OF UC1637-SP :

- Catalog: [UC1637](#)

NOTE: Qualified Version Definitions:

- Catalog - TI's standard catalog product

W (R-GDFP-F20)

CERAMIC DUAL FLATPACK



- NOTES:
- A. All linear dimensions are in inches (millimeters).
 - B. This drawing is subject to change without notice.
 - C. This package can be hermetically sealed with a ceramic lid using glass frit.
 - D. Index point is provided on cap for terminal identification only.
 - E. Falls within Mil-Std 1835 GDFP2-F20

IMPORTANT NOTICE

Texas Instruments Incorporated and its subsidiaries (TI) reserve the right to make corrections, enhancements, improvements and other changes to its semiconductor products and services per JESD46, latest issue, and to discontinue any product or service per JESD48, latest issue. Buyers should obtain the latest relevant information before placing orders and should verify that such information is current and complete. All semiconductor products (also referred to herein as "components") are sold subject to TI's terms and conditions of sale supplied at the time of order acknowledgment.

TI warrants performance of its components to the specifications applicable at the time of sale, in accordance with the warranty in TI's terms and conditions of sale of semiconductor products. Testing and other quality control techniques are used to the extent TI deems necessary to support this warranty. Except where mandated by applicable law, testing of all parameters of each component is not necessarily performed.

TI assumes no liability for applications assistance or the design of Buyers' products. Buyers are responsible for their products and applications using TI components. To minimize the risks associated with Buyers' products and applications, Buyers should provide adequate design and operating safeguards.

TI does not warrant or represent that any license, either express or implied, is granted under any patent right, copyright, mask work right, or other intellectual property right relating to any combination, machine, or process in which TI components or services are used. Information published by TI regarding third-party products or services does not constitute a license to use such products or services or a warranty or endorsement thereof. Use of such information may require a license from a third party under the patents or other intellectual property of the third party, or a license from TI under the patents or other intellectual property of TI.

Reproduction of significant portions of TI information in TI data books or data sheets is permissible only if reproduction is without alteration and is accompanied by all associated warranties, conditions, limitations, and notices. TI is not responsible or liable for such altered documentation. Information of third parties may be subject to additional restrictions.

Resale of TI components or services with statements different from or beyond the parameters stated by TI for that component or service voids all express and any implied warranties for the associated TI component or service and is an unfair and deceptive business practice. TI is not responsible or liable for any such statements.

Buyer acknowledges and agrees that it is solely responsible for compliance with all legal, regulatory and safety-related requirements concerning its products, and any use of TI components in its applications, notwithstanding any applications-related information or support that may be provided by TI. Buyer represents and agrees that it has all the necessary expertise to create and implement safeguards which anticipate dangerous consequences of failures, monitor failures and their consequences, lessen the likelihood of failures that might cause harm and take appropriate remedial actions. Buyer will fully indemnify TI and its representatives against any damages arising out of the use of any TI components in safety-critical applications.

In some cases, TI components may be promoted specifically to facilitate safety-related applications. With such components, TI's goal is to help enable customers to design and create their own end-product solutions that meet applicable functional safety standards and requirements. Nonetheless, such components are subject to these terms.

No TI components are authorized for use in FDA Class III (or similar life-critical medical equipment) unless authorized officers of the parties have executed a special agreement specifically governing such use.

Only those TI components which TI has specifically designated as military grade or "enhanced plastic" are designed and intended for use in military/aerospace applications or environments. Buyer acknowledges and agrees that any military or aerospace use of TI components which have **not** been so designated is solely at the Buyer's risk, and that Buyer is solely responsible for compliance with all legal and regulatory requirements in connection with such use.

TI has specifically designated certain components which meet ISO/TS16949 requirements, mainly for automotive use. Components which have not been so designated are neither designed nor intended for automotive use; and TI will not be responsible for any failure of such components to meet such requirements.

Products

Audio	www.ti.com/audio
Amplifiers	amplifier.ti.com
Data Converters	dataconverter.ti.com
DLP® Products	www.dlp.com
DSP	dsp.ti.com
Clocks and Timers	www.ti.com/clocks
Interface	interface.ti.com
Logic	logic.ti.com
Power Mgmt	power.ti.com
Microcontrollers	microcontroller.ti.com
RFID	www.ti-rfid.com
OMAP Applications Processors	www.ti.com/omap
Wireless Connectivity	www.ti.com/wirelessconnectivity

Applications

Automotive and Transportation	www.ti.com/automotive
Communications and Telecom	www.ti.com/communications
Computers and Peripherals	www.ti.com/computers
Consumer Electronics	www.ti.com/consumer-apps
Energy and Lighting	www.ti.com/energy
Industrial	www.ti.com/industrial
Medical	www.ti.com/medical
Security	www.ti.com/security
Space, Avionics and Defense	www.ti.com/space-avionics-defense
Video and Imaging	www.ti.com/video

TI E2E Community

e2e.ti.com