

Wide Input Voltage, Eco-mode™, Single Synchronous Step-Down Controller

Check for Samples: [TPS53219A](#)

FEATURES

- Conversion Input Voltage Range: 3 V to 28 V
- VDD Input Voltage Range: 4.5 V to 25 V
- Output Voltage Range: 0.6 V to 5.5 V
- Wide Output Load Range: 0 A to > 20 A
- Built-In 0.6-V ($\pm 0.8\%$) Reference
- Built-In LDO Linear Voltage Regulator
- Auto-Skip Eco-mode™ for Light-Load Efficiency
- D-CAP™ Mode with 100-ns Load-Step Response
- Adaptive On-Time Control Architecture with 8 Selectable Frequency Settings
- 4700ppm/°C $R_{DS(on)}$ Current Sensing
- 0.7-ms, 1.4-ms, 2.8-ms and 5.6-ms Selectable Internal Voltage Servo Soft-Start
- Pre-Charged Start-up Capability
- Built-In Output Discharge
- Open-Drain Power Good Output
- Integrated Boost Switch
- Built-in OVP/UVP/OCV
- Thermal Shutdown (Non-latch)
- 3 mm × 3 mm QFN, 16-Pin (RGT) Package

POINT-OF-LOAD APPLICATIONS

- Storage Computer
- Server Computer
- Multi-Function Printer
- Embedded Computing

DESCRIPTION

The TPS53219A is a small-sized single buck controller with adaptive on-time D-CAP™ mode control. The device is suitable for low output voltage, high current, PC system power rail and similar point-of-load (POL) power supplies in digital consumer products. The small package and minimal pin-count save space on the PCB, while the dedicated EN pin and pre-set frequency selections simplify the power supply design. The skip-mode at light load conditions, strong gate drivers and low-side FET $R_{DS(on)}$ current sensing supports low-loss and high efficiency, over a broad load range. The conversion input voltage (high-side FET drain voltage) range is between 4.5 V and 25 V, and the output voltage range is between 0.6 V and 5.5 V. The TPS53219A is available in a 16-pin, QFN package specified from -40°C to 85°C .

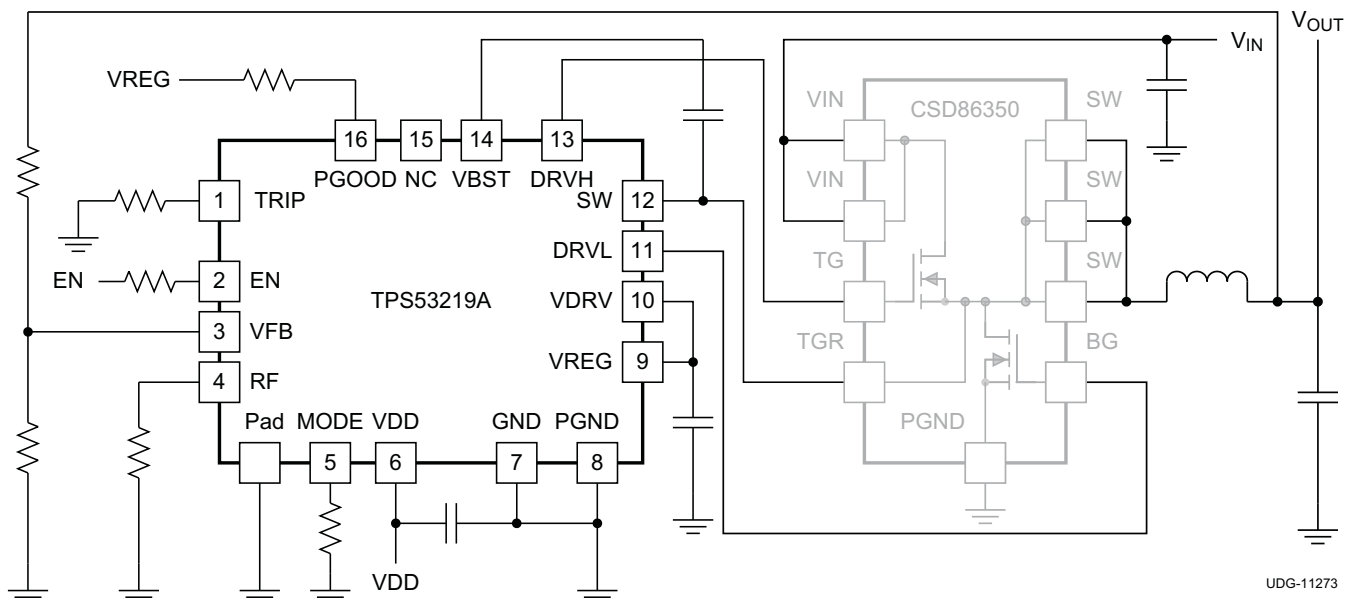

UDG-11273



Please be aware that an important notice concerning availability, standard warranty, and use in critical applications of Texas Instruments semiconductor products and disclaimers thereto appears at the end of this data sheet.

Eco-mode, D-CAP are trademarks of Texas Instruments.

TPS53219A

SLUSAU4 – DECEMBER 2011

www.ti.com

These devices have limited built-in ESD protection. The leads should be shorted together or the device placed in conductive foam during storage or handling to prevent electrostatic damage to the MOS gates.

ORDERING INFORMATION

TA	PACKAGE	ORDERING DEVICE NUMBER	PINS	OUTPUT SUPPLY	MINIMUM QUANTITY	ECO PLAN
-40°C to 85°C	Plastic QFN (RGT)	TPS53219ARGTR	16	Tape and reel	3000	Green (RoHS and no Pb/Br)
		TPS53219ARGTT	16	Mini-reel	250	

ABSOLUTE MAXIMUM RATINGS⁽¹⁾

over operating free-air temperature range (unless otherwise noted)

		VALUE	UNIT	
Input voltage range	VBST	-0.3 to 37	V	
	VBST ⁽²⁾	-0.3 to 7		
	VDD	-0.3 to 28		
	SW	DC		-2.0 to 30
		Pulse <20ns, E = 5 μJ		-7
	VDRV, EN, TRIP, VFB, RF, MODE	-0.3 to 7		
Output voltage range	DRVH	-2.0 to 37	V	
	DRVH ⁽²⁾	-0.3 to 7		
	DRVL, VREG	-0.5 to 7		
	PGOOD	-0.3 to 7		
T _J	Junction temperature range	150	°C	
T _{STG}	Storage temperature range	-55 to 150	°C	

- (1) Stresses beyond those listed under "absolute maximum ratings" may cause permanent damage to the device. These are stress ratings only and functional operation of the device at these or any other conditions beyond those indicated under "recommended operating conditions" is not implied. Exposure to absolute-maximum-rated conditions for extended periods may affect device reliability.
- (2) Voltage values are with respect to the SW terminal

THERMAL INFORMATION

THERMAL METRIC ⁽¹⁾		TPS53219A	UNITS
		16-PIN RGT	
θ _{JA}	Junction-to-ambient thermal resistance	51.3	°C/W
θ _{JCtop}	Junction-to-case (top) thermal resistance	85.4	
θ _{JB}	Junction-to-board thermal resistance	20.1	
ψ _{JT}	Junction-to-top characterization parameter	1.3	
ψ _{JB}	Junction-to-board characterization parameter	19.4	
θ _{JCbot}	Junction-to-case (bottom) thermal resistance	6.0	

- (1) For more information about traditional and new thermal metrics, see the *IC Package Thermal Metrics* application report, [SPRA953](#).

RECOMMENDED OPERATING CONDITIONS

over operating free-air temperature range (unless otherwise noted)

		MIN	TYP	MAX	UNIT
Input voltage range	VBST	-0.1		34.5	V
	VDD	4.5		25	
	SW	-1.0		28	
	VBST ⁽¹⁾	-0.1		6.5	
	EN, TRIP, VFB, RF, VDRV, MODE	-0.1		6.5	
Output voltage range	DRVH	-1.0		34.5	V
	DRVH ⁽¹⁾	-0.1		6.5	
	DRVL, VREG	-0.3		6.5	
	PGOOD	-0.1		6.5	
T _A	Operating free-air temperature		-40		85 °C

(1) Voltage values are with respect to the SW terminal.

ELECTRICAL CHARACTERISTICS

over operating free-air temperature range, VDD = 12 V (Unless otherwise noted)

PARAMETER		CONDITIONS	MIN	TYP	MAX	UNIT
SUPPLY CURRENT						
I _{VDD}	VDD supply current	VDD current, T _A = 25°C, No Load, V _{EN} = 5 V, V _{VFB} = 0.630 V		420	590	μA
I _{VDDSDN}	VDD shutdown current	VDD current, T _A = 25°C, No Load, V _{EN} = 0 V			10	μA
INTERNAL REFERENCE VOLTAGE						
V _{VFB}	VFB regulation voltage	VFB voltage, CCM condition ⁽¹⁾		600		mV
V _{VFB}	VFB regulation voltage	T _A = 25°C	597	600	603	mV
		0°C ≤ T _A ≤ 85°C	595.2	600.0	604.8	
		-40°C ≤ T _A ≤ 85°C	594	600	606	
I _{VFB}	VFB input current	V _{VFB} = 0.630V, T _A = 25°C		0.002	0.200	μA
OUTPUT DRIVERS						
R _{DRVH}	DRVH resistance	Source, I _{DRVH} = -50 mA		1.5	3	Ω
		Sink, I _{DRVH} = 50 mA		0.7	1.8	
R _{DRVL}	DRVL resistance	Source, I _{DRVL} = -50 mA		1.0	2.2	Ω
		Sink, I _{DRVL} = 50 mA		0.5	1.2	
t _{DEAD}	Dead time	DRVH-off to DRVL-on	7	17	30	ns
		DRVL-off to DRVH-on	10	22	35	
LDO OUTPUT						
V _{VREG}	LDO output voltage	0 mA ≤ I _{VREG} ≤ 50 mA	5.76	6.20	6.67	V
I _{VREG}	LDO output current ⁽¹⁾	Maximum current allowed from LDO			50	mA
V _{DO}	LDO drop out voltage	V _{VDD} = 4.5 V, I _{VREG} = 50 mA			364	mV
BOOT STRAP SWITCH						
V _{FBST}	Forward voltage	V _{VREG} -V _{BST} , I _F = 10 mA, T _A = 25°C		0.1	0.2	V
I _{VBSTLK}	VBST leakage current	V _{VBST} = 23 V, V _{SW} = 17 V, T _A = 25°C		0.01	1.5	μA
DUTY AND FREQUENCY CONTROL						
t _{OFF(min)}	Minimum off-time	T _A = 25°C	150	260	400	ns
t _{ON(min)}	Minimum on-time	V _{IN} = 17 V, V _{OUT} = 0.6 V, R _{RF} = 0 Ω to V _{VREG} , T _A = 25°C ⁽¹⁾		35		ns
SOFTSTART						
t _{SS}	Internal soft-start time	0 V ≤ V _{OUT} ≤ 95%, R _{MODE} = 39 kΩ		0.7		ms
		0 V ≤ V _{OUT} ≤ 95%, R _{MODE} = 100kΩ		1.4		
		0 V ≤ V _{OUT} ≤ 95%, R _{MODE} = 200 kΩ		2.8		
		0 V ≤ V _{OUT} ≤ 95%, R _{MODE} = 470 kΩ		5.6		
POWERGOOD						
V _{THPG}	PG threshold	PG in from lower	92.5%	96.0%	98.5%	
		PG in from higher	108%	111%	114%	
		PG hysteresis	2.5%	5.0%	7.8%	
R _{PG}	PG transistor on-resistance		15	30	50	Ω
t _{PG(del)}	PG delay after soft-start		0.8	1	1.2	ms

(1) Ensured by design. Not production tested.

ELECTRICAL CHARACTERISTICS

over operating free-air temperature range, VDD = 12 V (Unless otherwise noted)

PARAMETER		TEST CONDITIONS	MIN	TYP	MAX	UNIT
LOGIC THRESHOLD AND SETTING CONDITIONS						
V _{EN}	EN voltage threshold enable	-40°C ≤ T _A ≤ 85°C	1.8			V
		0°C ≤ T _A ≤ 85°C	1.7			
	EN voltage threshold disable		0.5			
I _{EN}	EN input current	V _{EN} = 5 V	1.0			μA
f _{SW}	Switching frequency	R _{RF} = 0 Ω to GND, T _A = 25°C ⁽¹⁾	200	250	300	kHz
		R _{RF} = 187 kΩ to GND, T _A = 25°C ⁽¹⁾	250	300	350	
		R _{RF} = 619 kΩ to GND, T _A = 25°C ⁽¹⁾	350	400	450	
		R _{RF} = Open, T _A = 25°C ⁽¹⁾	450	500	550	
		R _{RF} = 866 kΩ to V _{REG} , T _A = 25°C ⁽¹⁾	580	650	720	
		R _{RF} = 309 kΩ to V _{REG} , T _A = 25°C ⁽¹⁾	670	750	820	
		R _{RF} = 124 kΩ to V _{REG} , T _A = 25°C ⁽¹⁾	770	850	930	
		R _{RF} = 0 Ω to V _{REG} , T _A = 25°C ⁽¹⁾	880	970	1070	
VO DISCHARGE						
I _{Dischg}	VO discharge current	V _{EN} = 0 V, V _{SW} = 0.5 V	5	13		mA
PROTECTION: CURRENT SENSE						
I _{TRIP}	TRIP source current	V _{TRIP} = 1 V, T _A = 25°C	9	10	11	μA
TC _{ITRIP}	TRIP current temp. coef.	T _A = 25°C ⁽²⁾	4700			ppm/°C
V _{TRIP}	Current limit threshold setting range	V _{TRIP-GND} voltage	0.2		3	V
V _{OCL}	Current limit threshold	V _{TRIP} = 3.0 V	355	375	395	mV
		V _{TRIP} = 1.6 V	185	200	215	
		V _{TRIP} = 0.2 V	17	25	33	
V _{OCLN}	Negative current limit threshold	V _{TRIP} = 3.0 V	-406	-375	-355	mV
		V _{TRIP} = 1.6 V	-215	-200	-185	
		V _{TRIP} = 0.2 V	-33	-25	-17	
V _{AZC(adj)}	Auto zero cross adjustable range	Positive	3	15		mV
		Negative		-15	-3	
PROTECTION: UVP AND OVP						
V _{OVP}	OVP trip threshold voltage	OVP detect	115%	120%	125%	
t _{OVP(del)}	OVP propagation delay time	VFB delay with 50-mV overdrive	1			μs
V _{UVP}	Output UVP trip threshold voltage	UVP detect	65%	70%	75%	
t _{UVP(del)}	Output UVP propagation delay time		0.8	1	1.2	ms
t _{UVP(en)}	Output UVP enable delay time	from EN to UVP workable, R _{MODE} = 39 kΩ	2.00	2.55	3.00	ms
UVLO						
V _{UVVREG}	VREG UVLO threshold	Wake up	4.00	4.18	4.50	V
		Hysteresis	0.25			
THERMAL SHUTDOWN						
T _{SDN}	Thermal shutdown threshold	Shutdown temperature ⁽²⁾	145			°C
		Hysteresis ⁽²⁾	10			

(1) Not production tested. Test conditions are V_{IN} = 12 V, V_{OUT} = 1.1 V, I_{OUT} = 10 A and using the application circuit shown in [Figure 17](#) and [Figure 18](#).

(2) Ensured by design. Not production tested

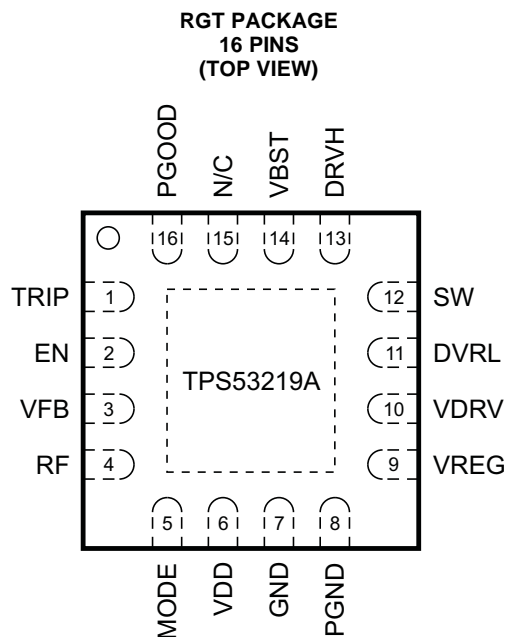
DEVICE INFORMATION

PIN FUNCTIONS

PIN NAME	PIN NO.	I/O/P ⁽¹⁾	DESCRIPTION
DRVH	13	O	High-side MOSFET driver output. The SW node referenced floating driver. The gate drive voltage is defined by the voltage across VBST to SW node bootstrap flying capacitor.
DRVH	11	O	Synchronous MOSFET driver output. The PGND referenced driver. The gate drive voltage is defined by VDRV voltage.
EN	2	I	Enable pin. Place a 1-kΩ resistor in series with this pin if the source voltage is higher than 5.5 V.
GND	7	G	Ground pin. This is the ground of internal analog circuitry. Connect to GND plane at single point.
MODE	5	I	Soft-start and skip/CCM selection. Connect a resistor to select soft-start time using Table 1 . The soft-start time is detected and stored into internal register during start-up.
NC	15	–	No connection.
PGOOD	16	O	Open drain power good flag. Provides 1-ms start up delay after the VFB pin voltage falls within specified limits. When VFB goes out specified limits PGOOD goes low after a 2-μs delay.
PGND	8	G	Power ground. Connect to GND plane.
RF	4	I	Switching frequency selection. Connect a resistor to GND or VREG to select switching frequency using Table 2 . The switching frequency is detected and stored during the startup.
SW	12	P	Output of converted power. Connect this pin to the output inductor.
TRIP	1	I	OCL detection threshold setting pin. 10 μA at room temp, 4700ppm/°C current is sourced and set the OCL trip voltage as follows. $V_{OCL} = V_{TRIP}/8$ ($V_{TRIP} \leq 3$ V, $V_{OCL} \leq 375$ mV)
VBST	14	P	Supply input for high-side FET gate driver (boost terminal). Connect a capacitor from this pin to SW-node. Internally connected to VREG via bootstrap MOSFET switch.
VDD	6	P	Controller power supply input. The input range is from 4.5 V to 25 V.
VDRV	10	I	Gate drive supply voltage input. Connect to VREG if using LDO output as gate drive supply.
VFB	3	I	Output feedback input. Connect this pin to V_{OUT} through a resistor divider.
VREG	9	O	6.2-V LDO output. This is the supply of internal analog circuitry and driver circuitry.
Pad	–	–	Thermal pad. Use five vias to connect to GND plane.

(1) I=Input, O=Output, P=Power, G=Ground

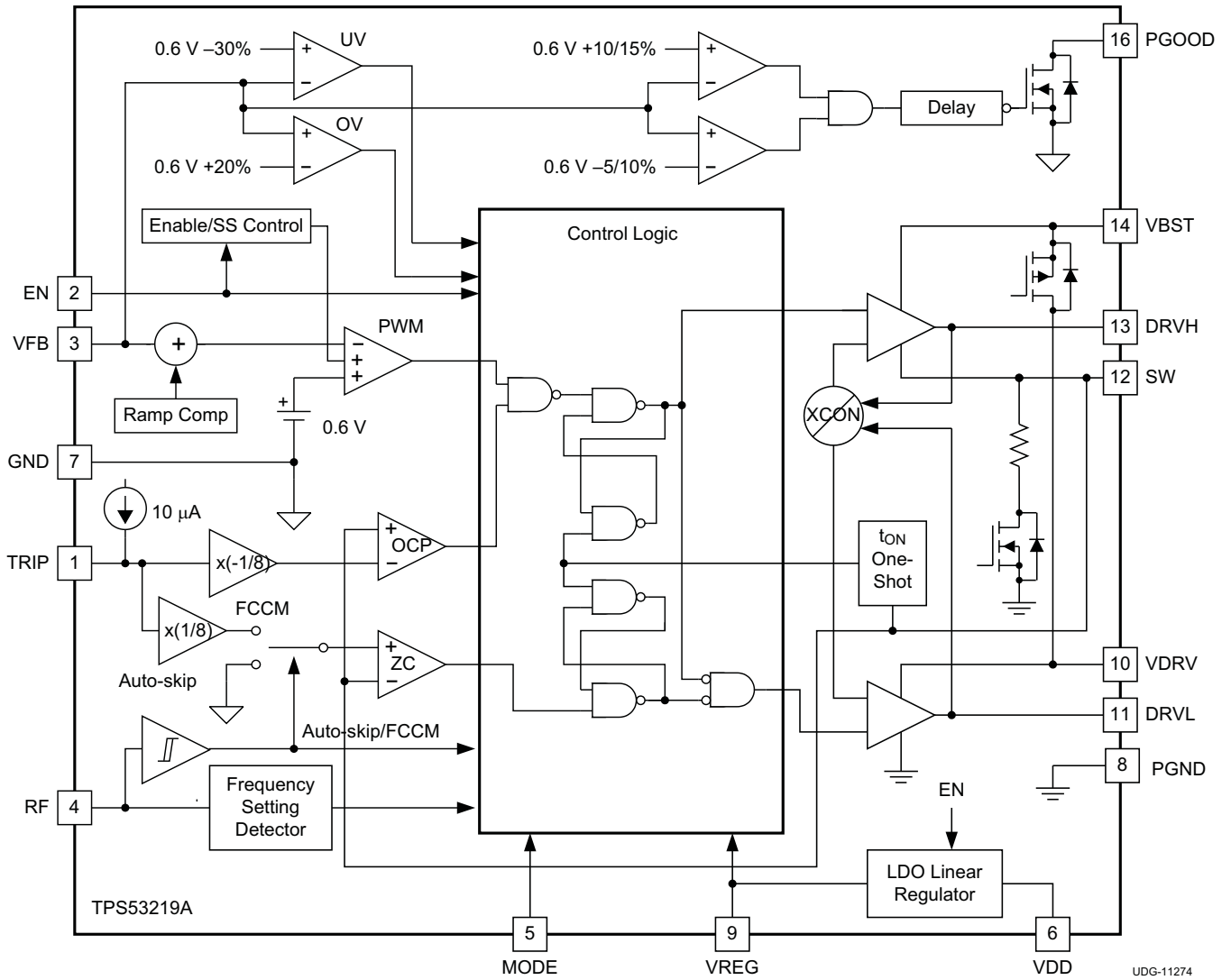
FUNCTIONAL BLOCK DIAGRAM



TYPICAL CHARACTERISTICS

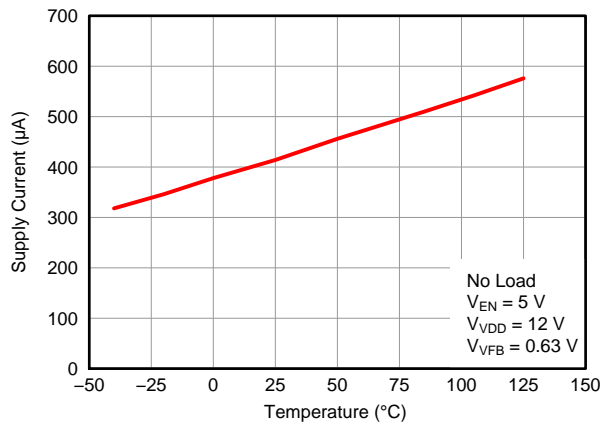

Figure 1. VDD Supply Current vs Temperature

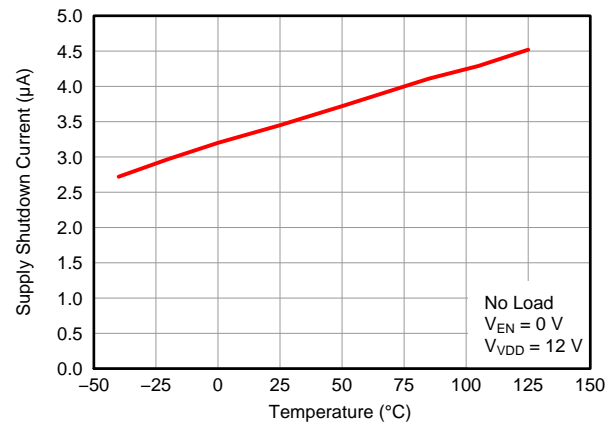

Figure 2. VDD Shutdown Current vs Temperature

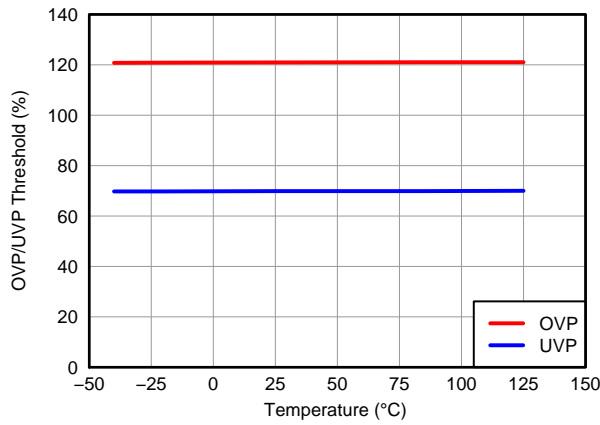

Figure 3. OVP/UVP Threshold vs Temperature

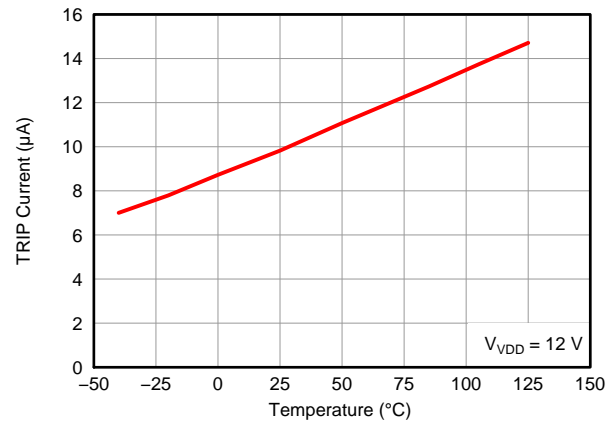

Figure 4. TRIP Pin Current vs Temperature

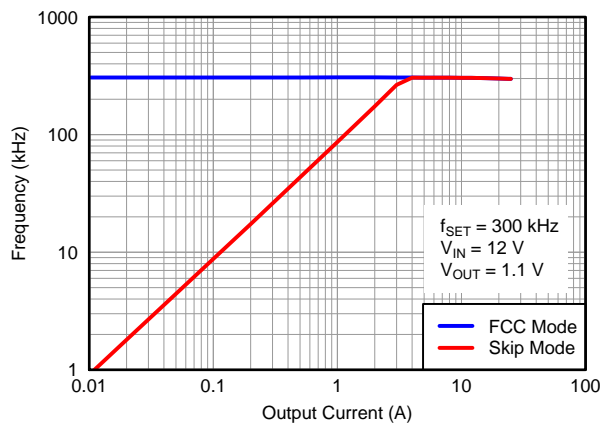

Figure 5. Switching Frequency vs Output Current

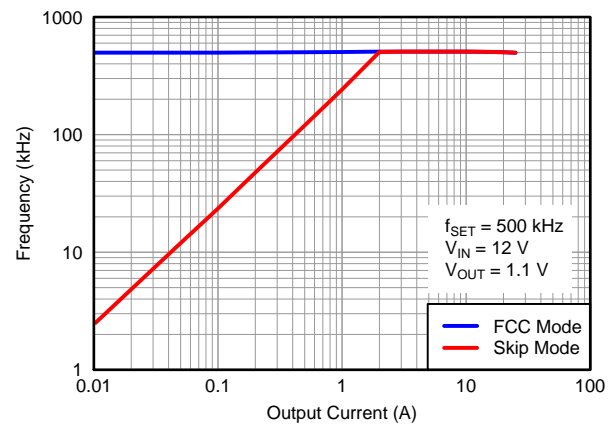

Figure 6. Switching Frequency vs Output Current

TYPICAL CHARACTERISTICS (continued)

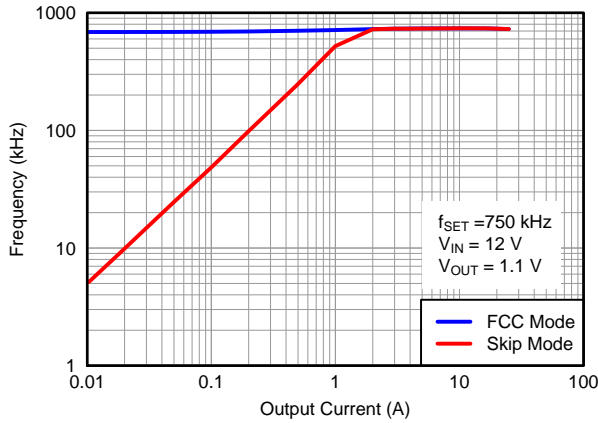

Figure 7. Switching Frequency vs Output Current

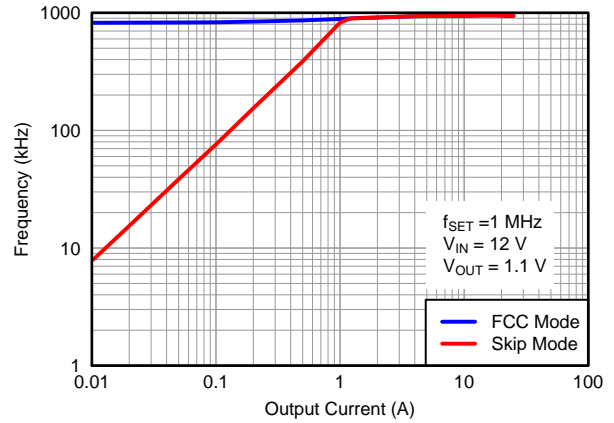

Figure 8. Switching Frequency vs Output Current

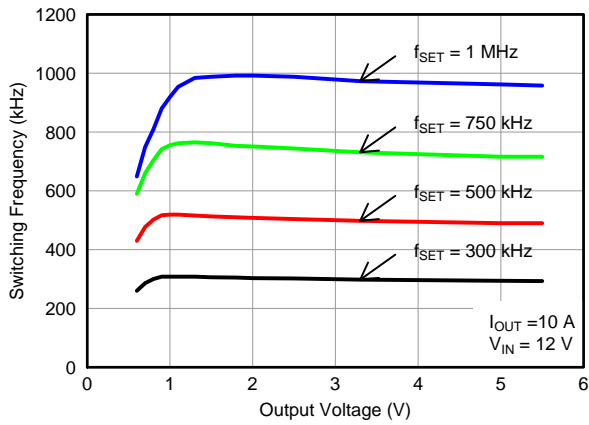

Figure 9. Switching Frequency vs Output Voltage

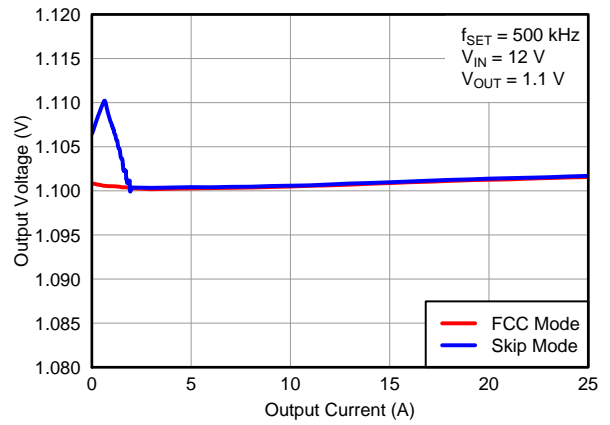

Figure 10. Output Voltage vs Output Current

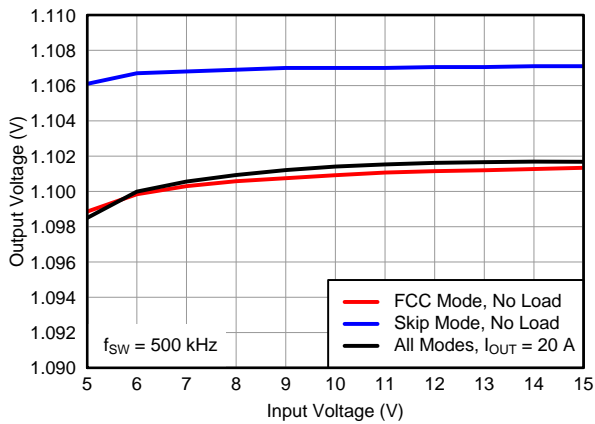

Figure 11. Output Voltage vs Input Voltage

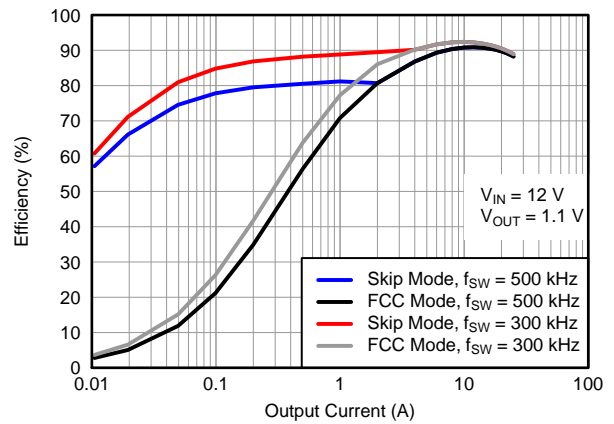

Figure 12. Efficiency vs Output Current

TYPICAL CHARACTERISTICS (continued)

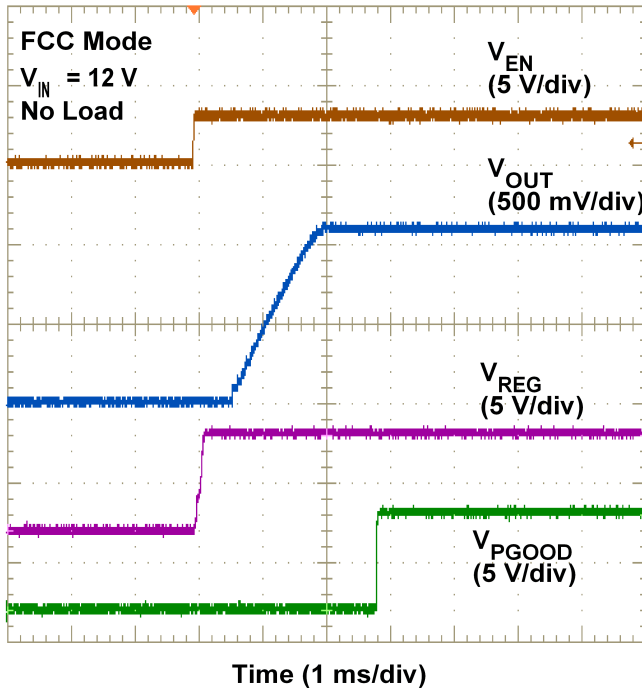

Figure 13. Start up Waveform

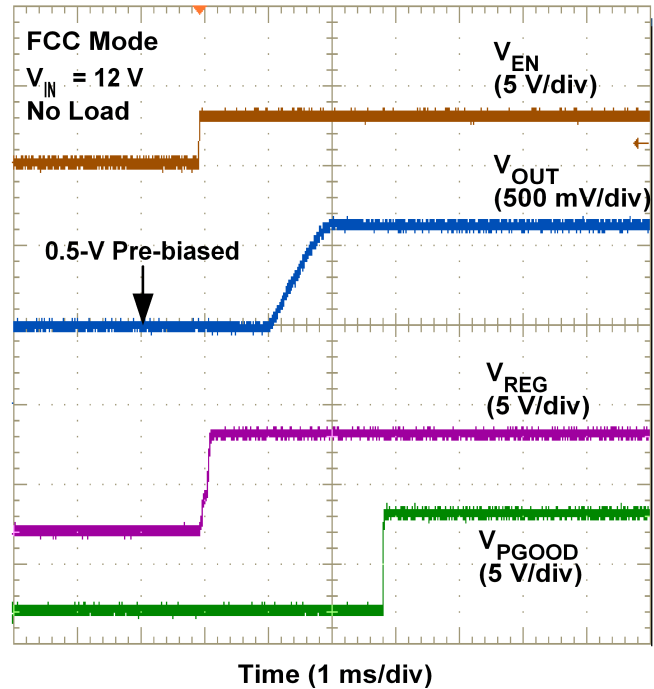

Figure 14. Pre-bias Start up Waveform

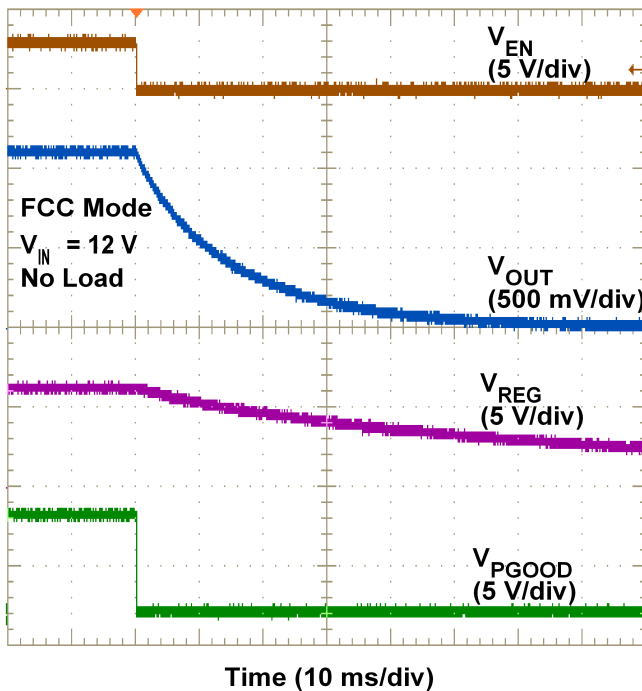

Figure 15. Turn Off Waveform

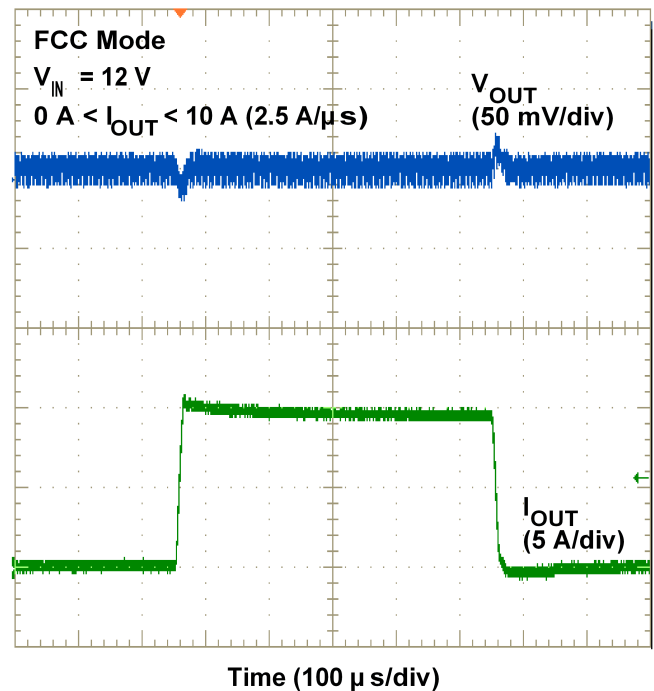

Figure 16. Load Transient Response

APPLICATION CIRCUIT DIAGRAM

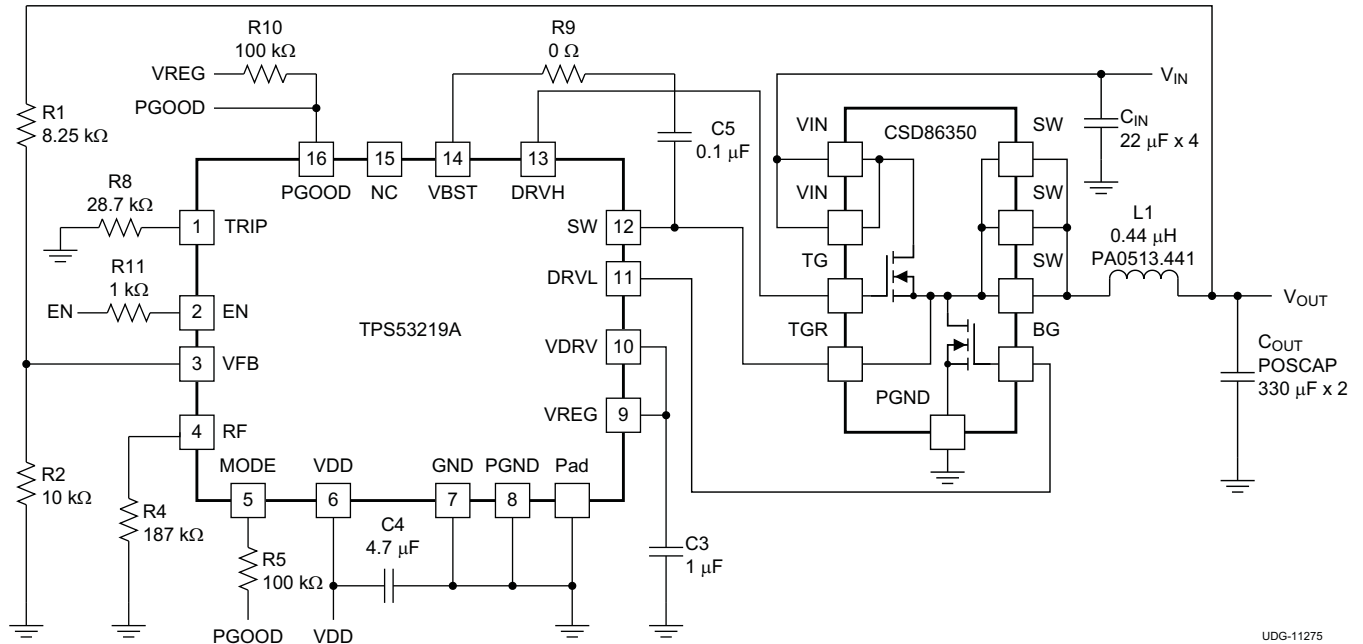

Figure 17. Typical Application Circuit Diagram with Power Block

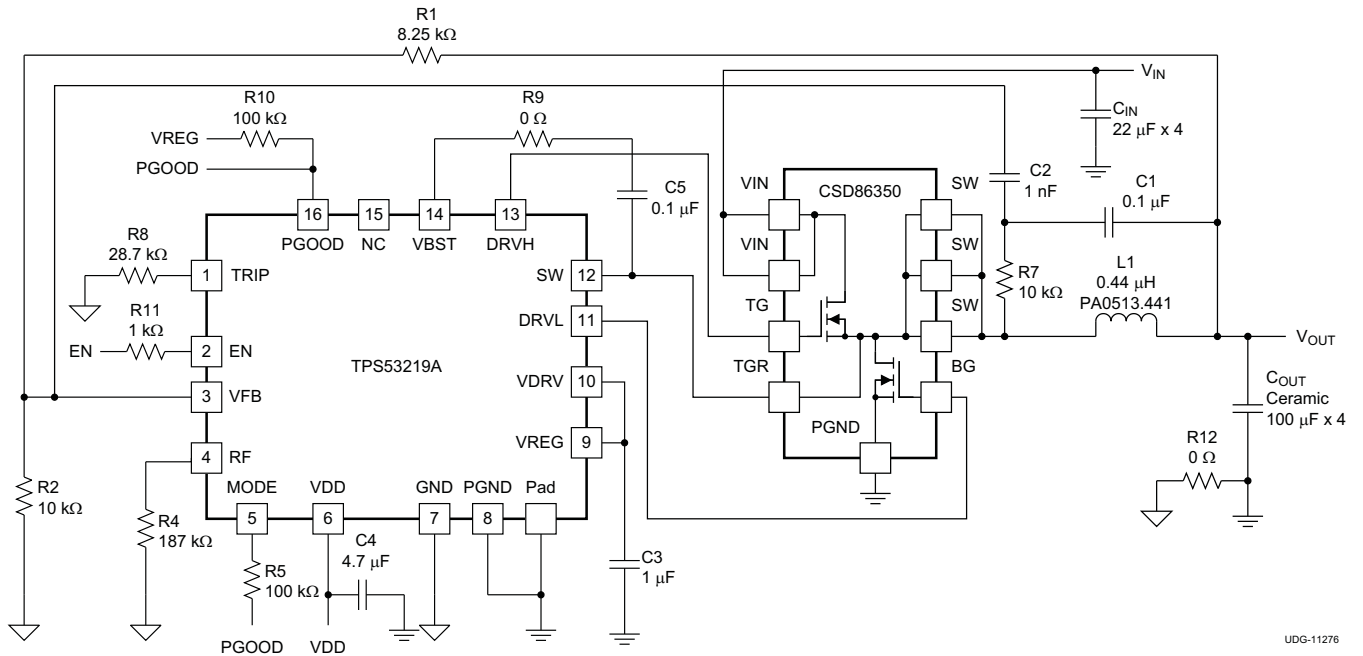

Figure 18. Typical Application Circuit Diagram with Ceramic Output Capacitors

General Description

The TPS53219A is a high-efficiency, single channel, synchronous buck regulator controller suitable for low output voltage point-of-load applications in computing and similar digital consumer applications. The device features proprietary D-CAP™ mode control combined with an adaptive on-time architecture. This combination is ideal for building modern low duty ratio, ultra-fast load step response DC-DC converters. The output voltage ranges from 0.6 V to 5.5 V. The conversion input voltage range is from 3 V up to 28V. The D-CAP™ mode uses the ESR of the output capacitor(s) to sense the device current. One advantage of this control scheme is that it does not require an external phase compensation network. This allows a simple design with a low external component count. Eight preset switching frequency values can be chosen using a resistor connected from the RF pin to ground or VREG. Adaptive on-time control tracks the preset switching frequency over a wide input and output voltage range while allowing the switching frequency to increase at the step-up of the load.

The TPS53219A has a MODE pin to select between auto-skip mode and forced continuous conduction mode (FCCM) for light load conditions. The MODE pin also sets the selectable soft-start time ranging from 0.7 ms to 5.6 ms as shown in Table 1. The strong gate drivers allow low $R_{DS(on)}$ FETs for high-current applications.

When the device starts (either by EN or VDD UVLO), the TPS53219A sends out a current that detects the resistance connected to the MODE pin to determine the soft-start time. After that (and before V_{OUT} start to ramp up) the MODE pin becomes a high-impedance input to determine skip mode or FCCM mode operation. When the voltage on the MODE pin is higher than 1.3 V, the converter enters into FCCM mode. If the voltage on MODE pin is less than 1.3 V, then the converter operates in skip mode.

It is recommended to connect the MODE pin to the PGOOD pin if FCCM mode is desired. In this configuration, the MODE pin is connected to the GND potential through a resistor when the device is detecting the soft-start time thus correct soft-start time is used. The device starts up in skip mode and only after the PGOOD pin goes high does the device enter into FCCM mode. When the PGOOD pin goes high there is a transition between skip mode and FCCM. A minimum off-time of 60 ns on DRV1 is provided to avoid a voltage spike on the DRV1 pin caused by parasitic inductance of the driver loop and gate capacitance of the low-side MOSFET.

For proper operation, the MODE pin must not be connected directly to a voltage source.

Enable and Soft-Start

When the EN pin voltage rises above the enable threshold voltage (typically 1.4 V), the controller enters its start-up sequence. The internal LDO regulator starts immediately and regulates to 6.2 V at the VREG pin. The controller then uses the first 250 μ s to calibrate the switching frequency setting resistance attached to the RF pin and stores the switching frequency code in internal registers. However, switching is inhibited during this phase. In the second phase, an internal DAC starts ramping up the reference voltage from 0 V to 0.6 V. Depending on the MODE pin setting, the ramping up time varies from 0.7 ms to 5.6 ms. Smooth and constant ramp-up of the output voltage is maintained during start-up regardless of load current.

Table 1. Soft-Start and MODE

MODE SELECTION	ACTION	SOFT-START TIME (ms)	R_{MODE} (k Ω)
Auto Skip	Pull down to GND	0.7	39
		1.4	100
		2.8	200
		5.6	475
Forced CCM ⁽¹⁾	Connect to PGOOD	0.7	39
		1.4	100
		2.8	200
		5.6	475

(1) Device goes into Forced CCM after PGOOD becomes high.

When the EN voltage is higher than 5.5 V, a 1-k Ω series resistor is needed for EN pin

Adaptive On-Time D-CAP™ Control and Frequency Selection

The TPS53219A does not have a dedicated oscillator that determines switching frequency. However, the device operates with pseudo-constant frequency by feed-forwarding the input and output voltages into the on-time one-shot timer. The adaptive on-time control adjusts the on-time to be inversely proportional to the input voltage and proportional to the output voltage ($t_{ON} \propto V_{OUT}/V_{IN}$).

This makes the switching frequency fairly constant in steady state conditions over a wide input voltage range. The switching frequency is selectable from eight preset values by a resistor connected between the RF pin and GND or between the RF pin and the VREG pin as shown in Table 2. (Leaving the resistance open sets the switching frequency to 500 kHz.)

Table 2. Resistor and Switching Frequency

RESISTOR (R _{RF}) CONNECTIONS	SWITCHING FREQUENCY (kHz)
0 Ω to GND	250
187 kΩ to GND	300
619 kΩ to GND	400
Open	500
866 kΩ to VREG	650
309 kΩ to VREG	750
124 kΩ to VREG	850
0 Ω to VREG	970

The off-time is modulated by a PWM comparator. The VFB node voltage (the mid-point of resistor divider) is compared to the internal 0.6-V reference voltage added with a ramp signal. When both signals match, the PWM comparator asserts a *set* signal to terminate the off time (turn off the low-side MOSFET and turn on high-side MOSFET). The *set* signal is valid if the inductor current level is below the OCP threshold, otherwise the off time is extended until the current level falls below the threshold.

Small Signal Model

From small-signal loop analysis, a buck converter using D-CAP™ mode can be simplified as shown in Figure 19.

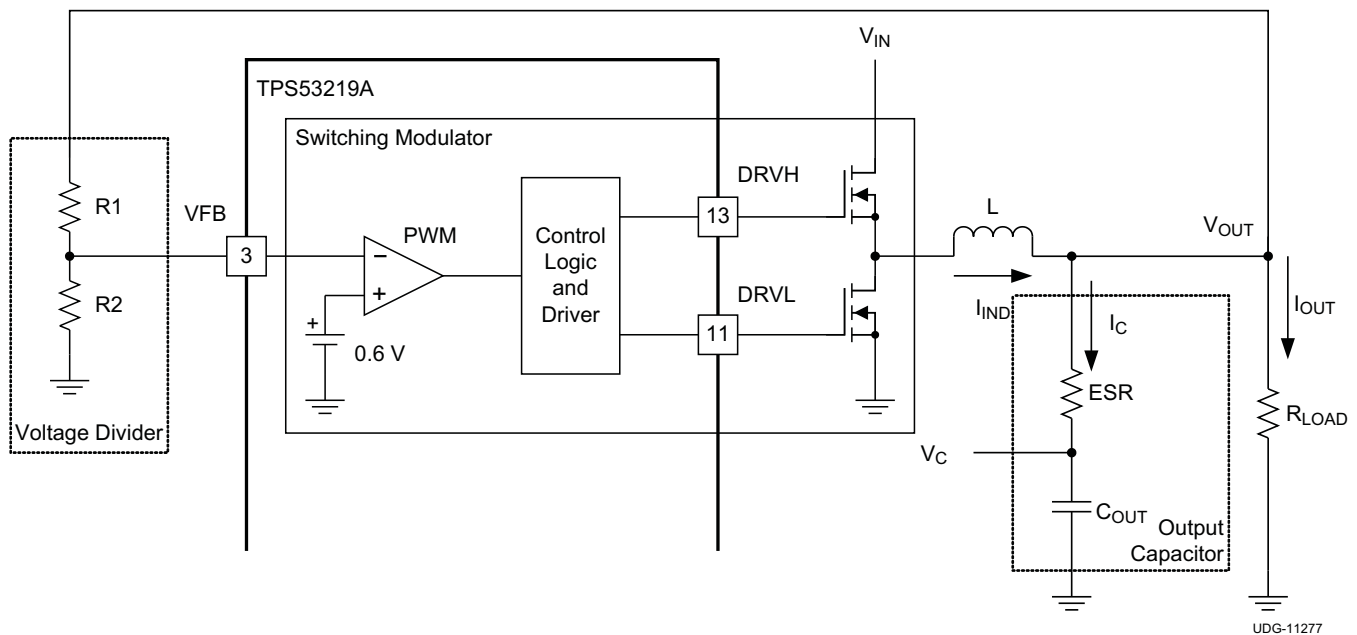

Figure 19. Simplified Modulator Model

The output voltage is compared with the internal reference voltage (ramp signal is ignored here for simplicity). The PWM comparator determines the timing to turn on the high-side MOSFET. The gain and speed of the comparator can be assumed high enough to keep the voltage at the beginning of each on cycle substantially constant.

$$H(s) = \frac{1}{s \times \text{ESR} \times C_{\text{OUT}}} \quad (1)$$

For the loop stability, the 0 dB frequency, f_0 , defined below must be lower than $\frac{1}{4}$ of the switching frequency.

$$f_0 = \frac{1}{2\pi \times \text{ESR} \times C_{\text{OUT}}} \leq \frac{f_{\text{SW}}}{4} \quad (2)$$

According to the equation above, the loop stability of D-CAP™ mode modulator is mainly determined by the capacitor chemistry. For example, specialty polymer capacitors (SP-CAP) have an output capacitance on the order of several 100 μF and ESR in range of 10 $\text{m}\Omega$. These yields an f_0 on the order of 100 kHz or less and a more stable loop. However, ceramic capacitors have an f_0 at more than 700 kHz, and require special care when used with this modulator. An application circuit for ceramic capacitor is described in section [External Parts Selection with All Ceramic Output Capacitors](#).

Ramp Signal

The TPS53219A adds a ramp signal to the 0.6-V reference in order to improve jitter performance. As described in the previous section, the feedback voltage is compared with the reference information to keep the output voltage in regulation. By adding a small ramp signal to the reference, the S/N ratio at the onset of a new switching cycle is improved. Therefore the operation becomes less jittery and more stable. The ramp signal is controlled to start with -7 mV at the beginning of an on-cycle and becomes 0 mV at the end of an off-cycle in steady state.

During skip mode operation, when the switching frequency is lower than 70% of the nominal frequency (because of longer off-time), the ramp signal exceeds 0 mV at the end of the off-time but is clamped at 3 mV to minimize DC offset.

Light Load Condition in Auto-Skip Operation

While the MODE pin is pulled low via R_{MODE} , TPS53219A automatically reduces the switching frequency at light load conditions to maintain high efficiency. Detailed operation is described as follows. As the output current decreases from heavy load condition, the inductor current is also reduced and eventually comes to the point that its rippled valley touches zero level, which is the boundary between continuous conduction and discontinuous conduction modes. The synchronous MOSFET is turned off when this zero inductor current is detected. As the load current further decreases, the converter runs into discontinuous conduction mode (DCM). The on-time is kept almost the same as it was in the continuous conduction mode so that it takes longer time to discharge the output capacitor with smaller load current to the level of the reference voltage. The transition point to the light load operation $I_{\text{O(LL)}}$ (i.e., the threshold between continuous and discontinuous conduction mode) can be calculated as shown in [Equation 3](#).

$$I_{\text{O(LL)}} = \frac{1}{2 \times L \times f_{\text{SW}}} \times \frac{(V_{\text{IN}} - V_{\text{OUT}}) \times V_{\text{OUT}}}{V_{\text{IN}}}$$

where

- f_{SW} is the PWM switching frequency (3)

Switching frequency versus output current in the light load condition is a function of L , V_{IN} and V_{OUT} , but it decreases almost proportionally to the output current from the $I_{\text{O(LL)}}$ given in [Equation 3](#). For example, it is 60 kHz at $I_{\text{O(LL)}}$ /5 if the frequency setting is 300 kHz.

Adaptive Zero Crossing

The TPS53219A has an adaptive zero crossing circuit which performs optimization of the zero inductor current detection at skip mode operation. This function pursues ideal low-side MOSFET turning off timing and compensates inherent offset voltage of the Z-C comparator and delay time of the Z-C detection circuit. It prevents SW-node swing-up caused by too late detection and minimizes diode conduction period caused by too early detection. As a result, better light load efficiency is delivered.

Forced Continuous Conduction Mode

When the MODE pin is tied to PGOOD through a resistor, the controller keeps continuous conduction mode (CCM) in light load condition. In this mode, switching frequency is kept almost constant over the entire load range which is suitable for applications need tight control of the switching frequency at a cost of lower efficiency.

Output Discharge Control

When EN becomes low, the TPS53219A discharges output capacitor using internal MOSFET connected between the SW pin and the PGND pin while the high-side and low-side MOSFETs are maintained in the *OFF* state. The typical discharge resistance is 40 Ω. The soft discharge occurs only as EN becomes low. After VREG becomes low, the internal MOSFET turns off and the discharge function becomes inactive.

Low-Side Driver

The low-side driver is designed to drive high-current low- $R_{DS(on)}$ N-channel MOSFET(s). The drive capability is represented by its internal resistance, which is 1.0 Ω for VDRV to DRV_L and 0.5 Ω for DRV_L to GND. A dead time to prevent shoot through is internally generated between high-side MOSFET off to low-side MOSFET on, and low-side MOSFET off to high-side MOSFET on. The bias voltage VDRV can be delivered from 6.2 V VREG supply or from external power source from 4.5 V to 6.5 V. The instantaneous drive current is supplied by an input capacitor connected between the VDRV and PGND pins.

The average low-side gate drive current is calculated in [Equation 4](#).

$$I_{GL} = C_{GL} \times V_{VDRV} \times f_{SW} \quad (4)$$

When VDRV is supplied by external voltage source, the device continues to be supplied by the VREG pin. There is no internal connection from VDRV to VREG.

High-Side Driver

The high-side driver is designed to drive high current, low $R_{DS(on)}$ N-channel MOSFET(s). When configured as a floating driver, the bias voltage is delivered from the VDRV pin supply. The average drive current is calculated using [Equation 5](#).

$$I_{GH} = C_{GH} \times V_{VDRV} \times f_{SW} \quad (5)$$

The instantaneous drive current is supplied by the flying capacitor between VBST and SW pins. The drive capability is represented by internal resistance, which is 1.5 Ω for VBST to DRV_H and 0.7 Ω for DRV_H to SW.

The driving power which needs to be dissipated from TPS53219A package.

$$P_{DRV} = (I_{GL} + I_{GH}) \times V_{VDRV} \quad (6)$$

Power Good

The TPS53219A has power-good output that indicates *high* when switcher output is within the target. The power-good function is activated after soft-start has finished. If the output voltage becomes within +10% or –5% of the target value, internal comparators detect power-good state and the power-good signal becomes high after a 1-ms internal delay. If the output voltage goes outside of +15% or –10% of the target value, the power-good signal becomes low after two microsecond (2-μs) internal delay. The power-good output is an open drain output and must be pulled up externally.

In order for the PGOOD logic to be valid, the VDD input must be higher than 1 V. To avoid invalid PGOOD logic before the TPS53219A is powered up, it is recommended that the PGOOD pin be pulled-up to VREG (either directly or through a resistor divider if a different pull-up voltage is desired) because VREG remains low when the device is powered off. The pull-up resistance can be chosen from a standard resistor value between 1 kΩ and 100 kΩ.

Current Sense and Overcurrent Protection

TPS53219A has cycle-by-cycle overcurrent limiting control. The inductor current is monitored during the *OFF* state and the controller maintains the *OFF* state during the period in that the inductor current is larger than the overcurrent trip level. In order to provide both good accuracy and cost effective solution, TPS53219A supports temperature compensated MOSFET $R_{DS(on)}$ sensing. The TRIP pin should be connected to GND through the trip voltage setting resistor, R_{TRIP} . The TRIP terminal sources I_{TRIP} current, which is 10 μ A typically at room temperature, and the trip level is set to the OCL trip voltage V_{TRIP} as shown in Equation 7. Note that the V_{TRIP} is limited up to approximately 3 V internally.

$$V_{TRIP} \text{ (mV)} = R_{TRIP} \text{ (k}\Omega\text{)} \times I_{TRIP} \text{ (\mu A)} \quad (7)$$

The inductor current is monitored by the voltage between GND pin and SW pin so that SW pin should be connected to the drain terminal of the low-side MOSFET properly. I_{TRIP} has 4700 ppm/ $^{\circ}$ C temperature slope to compensate the temperature dependency of the $R_{DS(on)}$. The GND pin is used as the positive current sensing node. The GND pin should be connected to the proper current sensing device, (for example, the source terminal of the low-side MOSFET.)

As the comparison is done during the *OFF* state, V_{TRIP} sets the valley level of the inductor current. Thus, the load current at the overcurrent threshold, I_{OCP} , can be calculated as shown in Equation 8.

$$I_{OCP} = \frac{V_{TRIP}}{(8 \times R_{DS(on)})} + \frac{I_{IND(ripple)}}{2} = \frac{V_{TRIP}}{(8 \times R_{DS(on)})} + \frac{1}{2 \times L \times f_{SW}} \times \frac{(V_{IN} - V_{OUT}) \times V_{OUT}}{V_{IN}} \quad (8)$$

In an overcurrent condition, the current to the load exceeds the current to the output capacitor thus the output voltage tends to fall down. Eventually, it crosses the undervoltage protection threshold and shuts down. After a hiccup delay (16 ms with 0.7 ms sort-start), the controller restarts. If the overcurrent condition remains, the procedure is repeated and the device enters hiccup mode.

During the CCM, the negative current limit (NCL) protects the external FET from carrying too much current. The NCL detect threshold is set as the same absolute value as positive OCL but negative polarity. Note that the threshold still represents the valley value of the inductor current.

Overvoltage and Undervoltage Protection

TPS53219A monitors a resistor divided feedback voltage to detect over and under voltage. When the feedback voltage becomes lower than 70% of the target voltage, the UVP comparator output goes high and an internal UVP delay counter begins counting. After 1ms, TPS53219A latches OFF both high-side and low-side MOSFETs drivers. The controller restarts after a hiccup delay (16 ms with 0.7 ms soft-start). This function is enabled 1.5-ms after the soft-start is completed.

When the feedback voltage becomes higher than 120% of the target voltage, the OVP comparator output goes high and the circuit latches OFF the high-side MOSFET driver and latches ON the low-side MOSFET driver. The output voltage decreases. If the output voltage reaches UV threshold, then both high-side MOSFET and low-side MOSFET driver will be OFF and the device restarts after an hiccup delay. If the OV condition remains, both high-side MOSFET and low-side MOSFET driver remains OFF until the OV condition is removed.

UVLO Protection

The TPS53219A uses VREG undervoltage lockout protection (UVLO). When the VREG voltage is lower than 3.95 V, the device shuts off. When the VREG voltage is higher than 4.2 V, the device restarts. This is non-latch protection.

Thermal Shutdown

The TPS53219A uses temperature monitoring. If the temperature exceeds the threshold value (typically 145 $^{\circ}$ C), the device is shut off. This is non-latch protection.

External Components Selection

Selecting external components is a simple process using D-CAP™ Mode.

1. CHOOSE THE INDUCTOR

The inductance should be determined to give the ripple current of approximately ¼ to ½ of maximum output current. Larger ripple current increases output ripple voltage and improves the signal-to-noise ratio and helps stable operation.

$$L = \frac{1}{I_{\text{IND(ripple)}} \times f_{\text{SW}}} \times \frac{(V_{\text{IN(max)}} - V_{\text{OUT}}) \times V_{\text{OUT}}}{V_{\text{IN(max)}}} = \frac{3}{I_{\text{OUT(max)}} \times f_{\text{SW}}} \times \frac{(V_{\text{IN(max)}} - V_{\text{OUT}}) \times V_{\text{OUT}}}{V_{\text{IN(max)}}} \quad (9)$$

The inductor also requires a low DCR to achieve good efficiency. It also requires enough room above the peak inductor current before saturation. The peak inductor current can be estimated in [Equation 10](#).

$$I_{\text{IND(peak)}} = \frac{V_{\text{TRIP}}}{8 \times R_{\text{DS(on)}}} + \frac{1}{L \times f_{\text{SW}}} \times \frac{(V_{\text{IN(max)}} - V_{\text{OUT}}) \times V_{\text{OUT}}}{V_{\text{IN(max)}}} \quad (10)$$

2. CHOOSE THE OUTPUT CAPACITOR(S)

When organic semiconductor capacitor(s) or specialty polymer capacitor(s) are used, for loop stability, capacitance and ESR should satisfy [Equation 2](#). For jitter performance, [Equation 11](#) is a good starting point to determine ESR.

$$\text{ESR} = \frac{V_{\text{OUT}} \times 10 \text{ mV} \times (1-D)}{0.6 \text{ V} \times I_{\text{IND(ripple)}}} = \frac{10 \text{ mV} \times L \times f_{\text{SW}}}{0.6 \text{ V}} = \frac{L \times f_{\text{SW}}}{60} \quad (\Omega)$$

where

- D is the duty factor
- the required output ripple slope is approximately 10 mV per t_{SW} (switching period) in terms of VFB terminal voltage

3. DETERMINE THE VALUE OF R1 AND R2

The output voltage is programmed by the voltage-divider resistor, R1 and R2 shown in [Figure 19](#). R1 is connected between the VFB pin and the output, and R2 is connected between the VFB pin and GND. Recommended R2 value is between 10 kΩ and 20 kΩ. Determine R1 using [Equation 12](#).

$$R1 = \frac{V_{\text{OUT}} - \left(\frac{I_{\text{IND(ripple)}} \times \text{ESR}}{2} \right) - 0.6}{0.6} \times R2 \quad (12)$$

External Parts Selection with All Ceramic Output Capacitors

When a ceramic output capacitor is used, the stability criteria in [Equation 2](#) cannot be satisfied. The ripple injection approach as shown in [Figure 18](#) is implemented to increase the ripple on the VFB pin and make the system stable. C2 can be fixed at 1 nF. The value of C1 can be selected between 10 nF to 200 nF.

The increased ripple on the VFB pin causes the increase of the VFB DC value. The AC ripple coupled to the VFB pin has two components, one coupled from SW node and the other coupled from V_{OUT} and they can be calculated using [Equation 13](#) and [Equation 14](#).

$$V_{\text{INJ(SW)}} = \frac{(V_{\text{IN}} - V_{\text{OUT}})}{R7 \times C1} \times \frac{D}{f_{\text{SW}}} \quad (13)$$

$$V_{\text{INJ(OUT)}} = \text{ESR} \times I_{\text{IND(ripple)}} + \frac{I_{\text{IND(ripple)}}}{8 \times C_{\text{OUT}} \times f_{\text{SW}}} \quad (14)$$

The DC value of VFB can be calculated by [Equation 15](#).

$$V_{\text{FB}} = 0.6 + \frac{(V_{\text{INJ(SW)}} + V_{\text{INJ(OUT)}})}{2} \quad (15)$$

And the resistor divider value can be determined by [Equation 16](#).

$$R1 = \frac{(V_{\text{OUT}} - V_{\text{FB}})}{V_{\text{FB}}} \times R2 \quad (16)$$

LAYOUT CONSIDERATIONS:

Certain points must be considered before starting a layout work using the TPS53219A.

- Inductor, V_{IN} capacitor(s), V_{OUT} capacitor(s) and MOSFETs are the power components and should be placed on one side of the PCB (solder side). Other small signal components should be placed on another side (component side). At least one inner plane should be inserted, connected to power ground, in order to shield and isolate the small signal traces from noisy power lines.
- All sensitive analog traces and components such as VFB, PGOOD, TRIP, MODE and RF should be placed away from high-voltage switching nodes such as SW, DRVL, DRVH or VBST to avoid coupling. Use internal layer(s) as ground plane(s) and shield feedback trace from power traces and components.
- The DC/DC converter has several high-current loops. The area of these loops should be minimized in order to suppress generating switching noise.
 - The most important loop to minimize the area of is the path from the V_{IN} capacitor(s) through the high and low-side MOSFETs, and back to the capacitor(s) through ground. Connect the negative node of the V_{IN} capacitor(s) and the source of the low-side MOSFET at ground as close as possible.
 - The second important loop is the path from the low-side MOSFET through inductor and V_{OUT} capacitor(s), and back to source of the low-side MOSFET through ground. Connect source of the low-side MOSFET and negative node of V_{OUT} capacitor(s) at ground as close as possible.
 - The third important loop is of gate driving system for the low-side MOSFET. To turn on the low-side MOSFET, high current flows from VDRV capacitor through gate driver and the low-side MOSFET, and back to negative node of the capacitor through ground. To turn off the low-side MOSFET, high current flows from gate of the low-side MOSFET through the gate driver and PGND of the device, and back to source of the low-side MOSFET through ground. Connect negative node of VDRV capacitor, source of the low-side MOSFET and PGND of the device at ground as close as possible.
- Because the TPS53219A controls output voltage referring to voltage across V_{OUT} capacitor, the high-side resistor of the voltage divider should be connected to the positive node of V_{OUT} capacitor at the regulation point. The low-side resistor should be connected to the GND (analog ground of the device). The trace from these resistors to the VFB pin should be short and thin. Place on the component side and avoid via(s) between these resistors and the device.
- Connect the overcurrent setting resistors from the TRIP pin to GND and make the connections as close as possible to the device. The trace from TRIP pin to resistor and from resistor to GND should avoid coupling to a high-voltage switching node.
- Connect the frequency setting resistor from RF pin to GND, or to the PGOOD pin, and make the connections as close as possible to the device. The trace from the RF pin to the resistor and from the resistor to GND should avoid coupling to a high-voltage switching node.
- Connect all GND (analog ground of the device) trace together and connect to power ground or ground plane with a single via or trace or through a 0- Ω resistor at a quiet point
- Connections from gate drivers to the respective gate of the high-side or the low-side MOSFET should be as short as possible to reduce stray inductance. Use 0.65 mm (25 mils) or wider trace and via(s) of at least 0.5 mm (20 mils) diameter along this trace.
- The PCB trace defined as switch node, which connects to source of high-side MOSFET, drain of low-side MOSFET and high-voltage side of the inductor, should be as short and wide as possible.
- Connect the ripple injection V_{OUT} signal (V_{OUT} side of the C1 capacitor in [Figure 18](#)) from the terminal of ceramic output capacitor. The AC coupling capacitor (C7 in [Figure 18](#)) can be placed near the device.

PACKAGING INFORMATION

Orderable Device	Status (1)	Package Type	Package Drawing	Pins	Package Qty	Eco Plan (2)	Lead/Ball Finish	MSL Peak Temp (3)	Op Temp (°C)	Top-Side Markings (4)	Samples
TPS53219ARGTR	ACTIVE	QFN	RGT	16	3000	Green (RoHS & no Sb/Br)	CU NIPDAU	Level-2-260C-1 YEAR	-40 to 85	3219A	Samples
TPS53219ARGTT	ACTIVE	QFN	RGT	16	250	Green (RoHS & no Sb/Br)	CU NIPDAU	Level-2-260C-1 YEAR	-40 to 85	3219A	Samples

(1) The marketing status values are defined as follows:

ACTIVE: Product device recommended for new designs.

LIFEBUY: TI has announced that the device will be discontinued, and a lifetime-buy period is in effect.

NRND: Not recommended for new designs. Device is in production to support existing customers, but TI does not recommend using this part in a new design.

PREVIEW: Device has been announced but is not in production. Samples may or may not be available.

OBSOLETE: TI has discontinued the production of the device.

(2) Eco Plan - The planned eco-friendly classification: Pb-Free (RoHS), Pb-Free (RoHS Exempt), or Green (RoHS & no Sb/Br) - please check <http://www.ti.com/productcontent> for the latest availability information and additional product content details.

TBD: The Pb-Free/Green conversion plan has not been defined.

Pb-Free (RoHS): TI's terms "Lead-Free" or "Pb-Free" mean semiconductor products that are compatible with the current RoHS requirements for all 6 substances, including the requirement that lead not exceed 0.1% by weight in homogeneous materials. Where designed to be soldered at high temperatures, TI Pb-Free products are suitable for use in specified lead-free processes.

Pb-Free (RoHS Exempt): This component has a RoHS exemption for either 1) lead-based flip-chip solder bumps used between the die and package, or 2) lead-based die adhesive used between the die and leadframe. The component is otherwise considered Pb-Free (RoHS compatible) as defined above.

Green (RoHS & no Sb/Br): TI defines "Green" to mean Pb-Free (RoHS compatible), and free of Bromine (Br) and Antimony (Sb) based flame retardants (Br or Sb do not exceed 0.1% by weight in homogeneous material)

(3) MSL, Peak Temp. -- The Moisture Sensitivity Level rating according to the JEDEC industry standard classifications, and peak solder temperature.

(4) Multiple Top-Side Markings will be inside parentheses. Only one Top-Side Marking contained in parentheses and separated by a "~" will appear on a device. If a line is indented then it is a continuation of the previous line and the two combined represent the entire Top-Side Marking for that device.

Important Information and Disclaimer: The information provided on this page represents TI's knowledge and belief as of the date that it is provided. TI bases its knowledge and belief on information provided by third parties, and makes no representation or warranty as to the accuracy of such information. Efforts are underway to better integrate information from third parties. TI has taken and continues to take reasonable steps to provide representative and accurate information but may not have conducted destructive testing or chemical analysis on incoming materials and chemicals. TI and TI suppliers consider certain information to be proprietary, and thus CAS numbers and other limited information may not be available for release.

In no event shall TI's liability arising out of such information exceed the total purchase price of the TI part(s) at issue in this document sold by TI to Customer on an annual basis.

TAPE AND REEL INFORMATION
REEL DIMENSIONS

TAPE DIMENSIONS

A0	Dimension designed to accommodate the component width
B0	Dimension designed to accommodate the component length
K0	Dimension designed to accommodate the component thickness
W	Overall width of the carrier tape
P1	Pitch between successive cavity centers

TAPE AND REEL INFORMATION

*All dimensions are nominal

Device	Package Type	Package Drawing	Pins	SPQ	Reel Diameter (mm)	Reel Width W1 (mm)	A0 (mm)	B0 (mm)	K0 (mm)	P1 (mm)	W (mm)	Pin1 Quadrant
TPS53219ARGTR	QFN	RGT	16	3000	330.0	12.4	3.3	3.3	1.1	8.0	12.0	Q2
TPS53219ARGTT	QFN	RGT	16	250	180.0	12.4	3.3	3.3	1.1	8.0	12.0	Q2

TAPE AND REEL BOX DIMENSIONS

*All dimensions are nominal

Device	Package Type	Package Drawing	Pins	SPQ	Length (mm)	Width (mm)	Height (mm)
TPS53219ARGTR	QFN	RGT	16	3000	367.0	367.0	35.0
TPS53219ARGTT	QFN	RGT	16	250	210.0	185.0	35.0

RGT (S-PVQFN-N16)

PLASTIC QUAD FLATPACK NO-LEAD

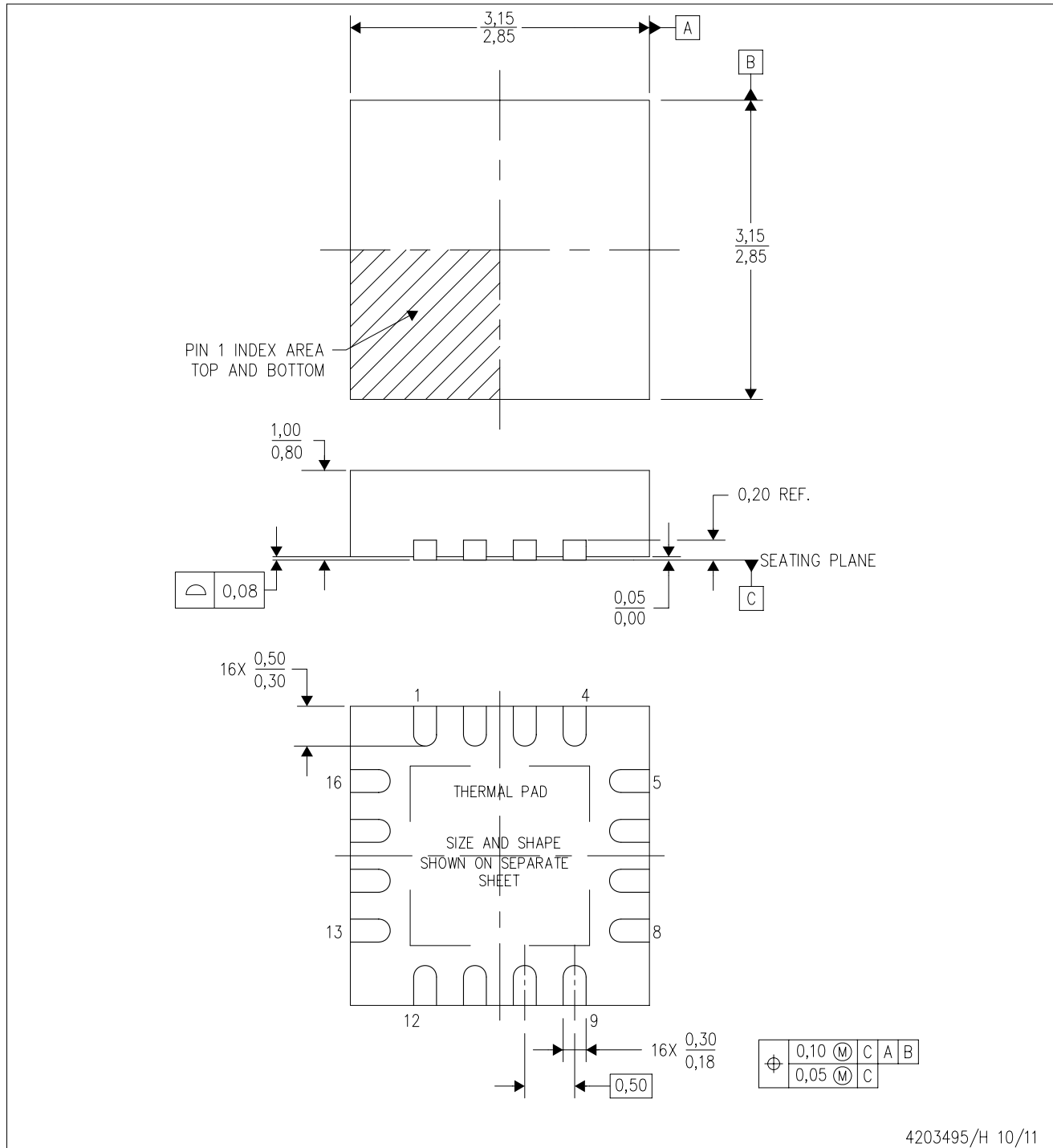

4203495/H 10/11

- NOTES:
- All linear dimensions are in millimeters. Dimensioning and tolerancing per ASME Y14.5M-1994.
 - This drawing is subject to change without notice.
 - Quad Flatpack, No-leads (QFN) package configuration.
 - The package thermal pad must be soldered to the board for thermal and mechanical performance.
 - See the additional figure in the Product Data Sheet for details regarding the exposed thermal pad features and dimensions.
 - Falls within JEDEC MO-220.

THERMAL PAD MECHANICAL DATA

RGT (S-PVQFN-N16)

PLASTIC QUAD FLATPACK NO-LEAD

THERMAL INFORMATION

This package incorporates an exposed thermal pad that is designed to be attached directly to an external heatsink. The thermal pad must be soldered directly to the printed circuit board (PCB). After soldering, the PCB can be used as a heatsink. In addition, through the use of thermal vias, the thermal pad can be attached directly to the appropriate copper plane shown in the electrical schematic for the device, or alternatively, can be attached to a special heatsink structure designed into the PCB. This design optimizes the heat transfer from the integrated circuit (IC).

For information on the Quad Flatpack No-Lead (QFN) package and its advantages, refer to Application Report, QFN/SON PCB Attachment, Texas Instruments Literature No. SLUA271. This document is available at www.ti.com.

The exposed thermal pad dimensions for this package are shown in the following illustration.

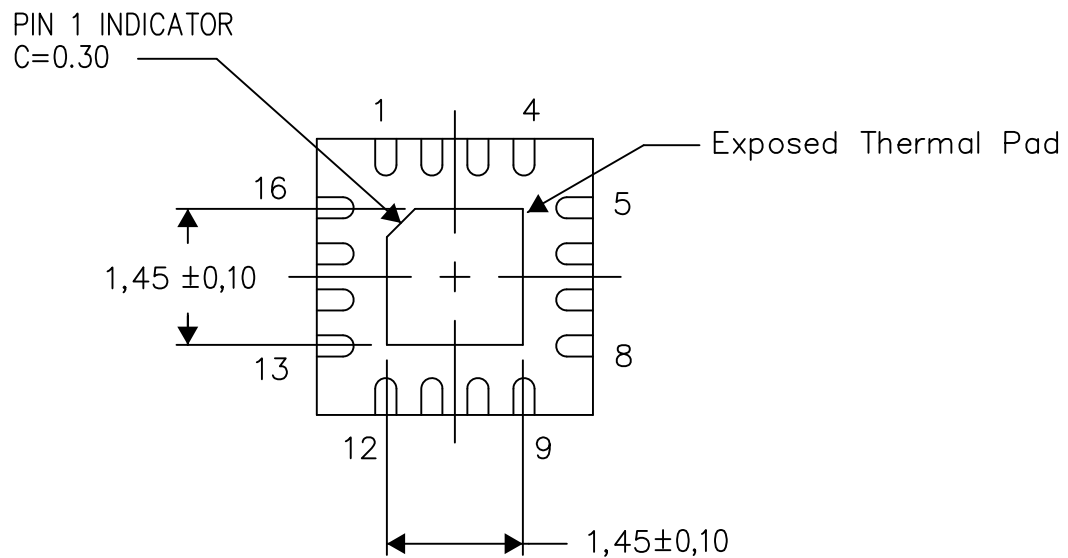

Bottom View

Exposed Thermal Pad Dimensions

4206349-2/S 04/13

NOTE: All linear dimensions are in millimeters

RGT (S-PVQFN-N16)

PLASTIC QUAD FLATPACK NO-LEAD

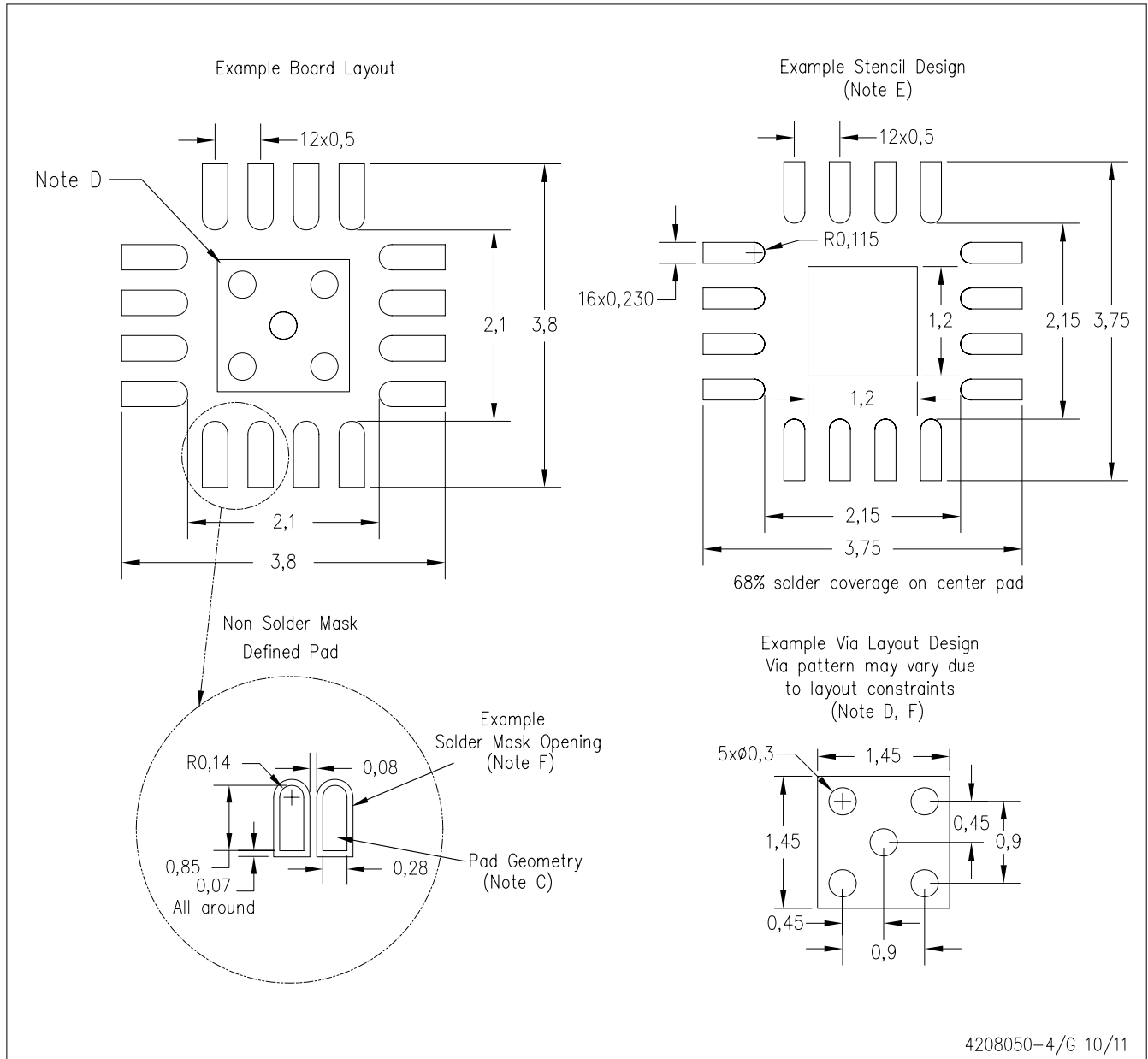

- NOTES:
- A. All linear dimensions are in millimeters.
 - B. This drawing is subject to change without notice.
 - C. Publication IPC-7351 is recommended for alternate designs.
 - D. This package is designed to be soldered to a thermal pad on the board. Refer to Application Note, QFN/SON PCB Attachment, Texas Instruments Literature No. SLUA271, and also the Product Data Sheets for specific thermal information, via requirements, and recommended board layout. These documents are available at www.ti.com <<http://www.ti.com>>.
 - E. Laser cutting apertures with trapezoidal walls and also rounding corners will offer better paste release. Customers should contact their board assembly site for stencil design recommendations. Refer to IPC 7525 for stencil design considerations.
 - F. Customers should contact their board fabrication site for minimum solder mask web tolerances between signal pads.

IMPORTANT NOTICE

Texas Instruments Incorporated and its subsidiaries (TI) reserve the right to make corrections, enhancements, improvements and other changes to its semiconductor products and services per JESD46, latest issue, and to discontinue any product or service per JESD48, latest issue. Buyers should obtain the latest relevant information before placing orders and should verify that such information is current and complete. All semiconductor products (also referred to herein as "components") are sold subject to TI's terms and conditions of sale supplied at the time of order acknowledgment.

TI warrants performance of its components to the specifications applicable at the time of sale, in accordance with the warranty in TI's terms and conditions of sale of semiconductor products. Testing and other quality control techniques are used to the extent TI deems necessary to support this warranty. Except where mandated by applicable law, testing of all parameters of each component is not necessarily performed.

TI assumes no liability for applications assistance or the design of Buyers' products. Buyers are responsible for their products and applications using TI components. To minimize the risks associated with Buyers' products and applications, Buyers should provide adequate design and operating safeguards.

TI does not warrant or represent that any license, either express or implied, is granted under any patent right, copyright, mask work right, or other intellectual property right relating to any combination, machine, or process in which TI components or services are used. Information published by TI regarding third-party products or services does not constitute a license to use such products or services or a warranty or endorsement thereof. Use of such information may require a license from a third party under the patents or other intellectual property of the third party, or a license from TI under the patents or other intellectual property of TI.

Reproduction of significant portions of TI information in TI data books or data sheets is permissible only if reproduction is without alteration and is accompanied by all associated warranties, conditions, limitations, and notices. TI is not responsible or liable for such altered documentation. Information of third parties may be subject to additional restrictions.

Resale of TI components or services with statements different from or beyond the parameters stated by TI for that component or service voids all express and any implied warranties for the associated TI component or service and is an unfair and deceptive business practice. TI is not responsible or liable for any such statements.

Buyer acknowledges and agrees that it is solely responsible for compliance with all legal, regulatory and safety-related requirements concerning its products, and any use of TI components in its applications, notwithstanding any applications-related information or support that may be provided by TI. Buyer represents and agrees that it has all the necessary expertise to create and implement safeguards which anticipate dangerous consequences of failures, monitor failures and their consequences, lessen the likelihood of failures that might cause harm and take appropriate remedial actions. Buyer will fully indemnify TI and its representatives against any damages arising out of the use of any TI components in safety-critical applications.

In some cases, TI components may be promoted specifically to facilitate safety-related applications. With such components, TI's goal is to help enable customers to design and create their own end-product solutions that meet applicable functional safety standards and requirements. Nonetheless, such components are subject to these terms.

No TI components are authorized for use in FDA Class III (or similar life-critical medical equipment) unless authorized officers of the parties have executed a special agreement specifically governing such use.

Only those TI components which TI has specifically designated as military grade or "enhanced plastic" are designed and intended for use in military/aerospace applications or environments. Buyer acknowledges and agrees that any military or aerospace use of TI components which have **not** been so designated is solely at the Buyer's risk, and that Buyer is solely responsible for compliance with all legal and regulatory requirements in connection with such use.

TI has specifically designated certain components as meeting ISO/TS16949 requirements, mainly for automotive use. In any case of use of non-designated products, TI will not be responsible for any failure to meet ISO/TS16949.

Products

Audio	www.ti.com/audio
Amplifiers	amplifier.ti.com
Data Converters	dataconverter.ti.com
DLP® Products	www.dlp.com
DSP	dsp.ti.com
Clocks and Timers	www.ti.com/clocks
Interface	interface.ti.com
Logic	logic.ti.com
Power Mgmt	power.ti.com
Microcontrollers	microcontroller.ti.com
RFID	www.ti-rfid.com
OMAP Applications Processors	www.ti.com/omap
Wireless Connectivity	www.ti.com/wirelessconnectivity

Applications

Automotive and Transportation	www.ti.com/automotive
Communications and Telecom	www.ti.com/communications
Computers and Peripherals	www.ti.com/computers
Consumer Electronics	www.ti.com/consumer-apps
Energy and Lighting	www.ti.com/energy
Industrial	www.ti.com/industrial
Medical	www.ti.com/medical
Security	www.ti.com/security
Space, Avionics and Defense	www.ti.com/space-avionics-defense
Video and Imaging	www.ti.com/video

TI E2E Community

e2e.ti.com