

Dual Synchronous, Step-Down Controller with 5-V and 3.3-V LDOs

 Check for Samples: [TPS51225](#), [TPS51225B](#), [TPS51225C](#)

FEATURES

- Input Voltage Range: 5.5 V to 24 V
- Output Voltages: 5 V and 3.3 V (Adjustable Range $\pm 10\%$)
- Built-in, 100-mA, 5-V and 3.3-V LDOs
- Clock Output for Charge-Pump
- $\pm 1\%$ Reference Accuracy
- Adaptive On-time D-CAP™ Mode Control Architecture with 300kHz/355kHz Frequency Setting
- Auto-skip Light Load Operation (TPS51225/C)
- OOA Light Load Operation (TPS51225B)
- Internal 0.8-ms Voltage Servo Soft-Start
- Low-Side $R_{DS(on)}$ Current Sensing Scheme with 4500 ppm/°C Temperature Coefficient
- Built-in Output Discharge Function
- Separate Enable Input for Switchers (TPS51225/B/C)
- Dedicated OC Setting Terminals
- Power Good Indicator
- OVP/UVP/OC Protection
- Non-latch UVLO/OTP Protection
- 20-Pin, 3 mm × 3 mm, QFN (RUK)

APPLICATIONS

- Notebook Computers
- Netbook, Tablet Computers

DESCRIPTION

The TPS51225/B/C is a cost-effective, dual-synchronous buck controller targeted for notebook system-power supply solutions. It provides 5-V and 3.3-V LDOs and requires few external components. The 260-kHz VCLK output can be used to drive an external charge pump, generating gate drive voltage for the load switches without reducing the main converter efficiency. The TPS51225/B/C supports high efficiency, fast transient response and provides a combined power-good signal. Adaptive on-time, D-CAP™ control provides convenient and efficient operation. The device operates with supply input voltage ranging from 5.5 V to 24 V and supports output voltages of 5.0 V and 3.3 V. The TPS51225/B/C is available in a 20-pin, 3 mm × 3 mm, QFN package and is specified from -40°C to 85°C .

ORDERING INFORMATION⁽¹⁾

ORDERABLE DEVICE NUMBER	ENABLE FUNCTION	SKIP MODE	ALWAYS ON-LDO	PACKAGE	OUTPUT SUPPLY	QUANTITY
TPS51225RUKR	EN1/ EN2	Auto-skip	VREG3	PLASTIC Quad Flat Pack (20 pin QFN)	Tape and Reel	3000
TPS51225RUKT					Mini reel	250
TPS51225BRUKR	EN1/ EN2	OOA	VREG3		Tape and Reel	3000
TPS51225BRUKT					Mini reel	250
TPS51225CRUKR	EN1/ EN2	Auto-skip	VREG3 & VREG5		Tape and Reel	3000
TPS51225CRUKT					Mini reel	250

(1) For the most current package and ordering information see the Package Option Addendum at the end of this document, or see the TI website at www.ti.com.



Please be aware that an important notice concerning availability, standard warranty, and use in critical applications of Texas Instruments semiconductor products and disclaimers thereto appears at the end of this data sheet.

D-CAP, Out-of-Audio are trademarks of Texas Instruments.

TPS51225, TPS51225B, TPS51225C

SLUSAV0B – JANUARY 2012 – REVISED SEPTEMBER 2012

www.ti.com



These devices have limited built-in ESD protection. The leads should be shorted together or the device placed in conductive foam during storage or handling to prevent electrostatic damage to the MOS gates.

TYPICAL APPLICATION DIAGRAM (TPS51225/TPS51225B)

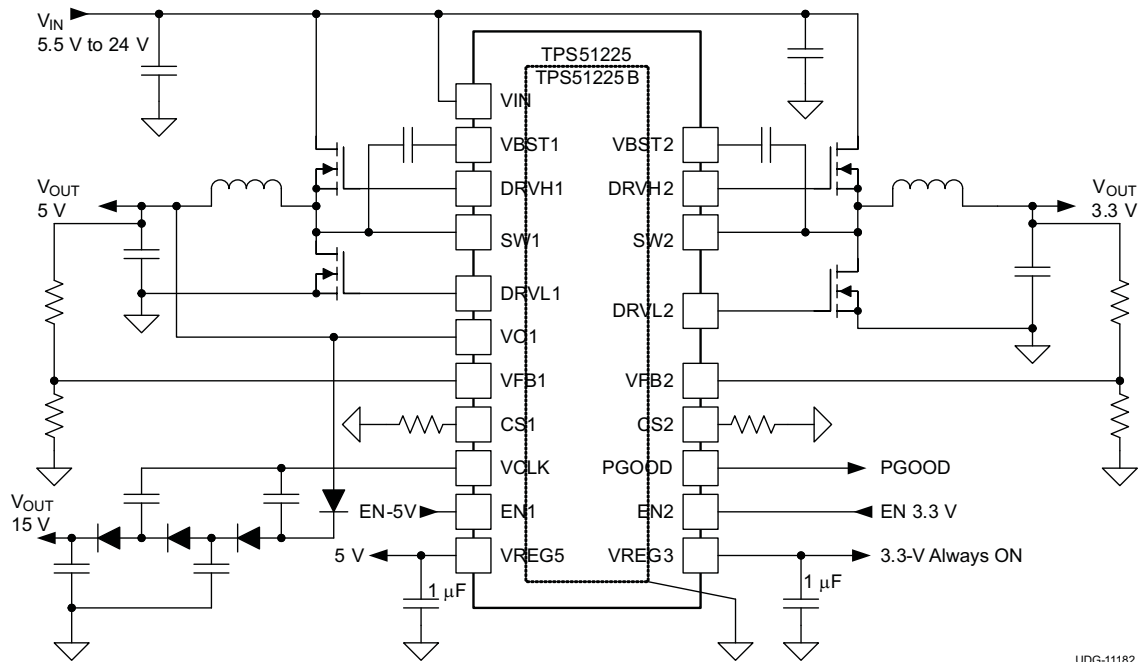

TYPICAL APPLICATION DIAGRAM (TPS51225C)

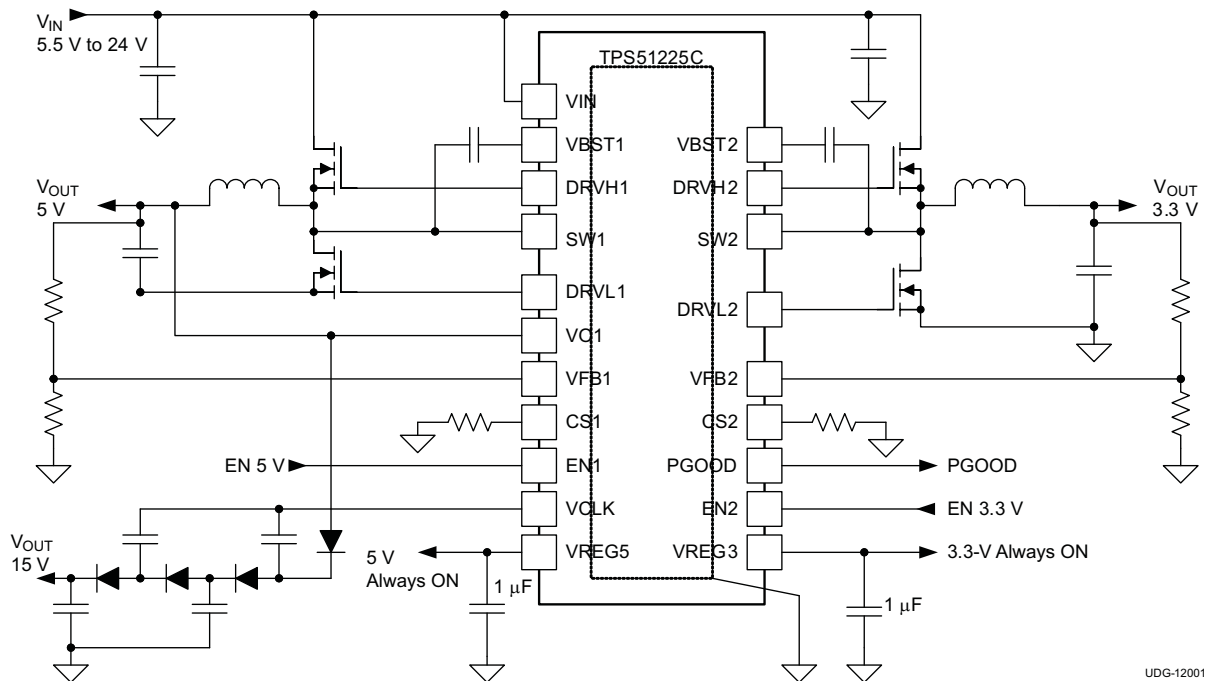

ABSOLUTE MAXIMUM RATINGS⁽¹⁾

over operating free-air temperature range (unless otherwise noted)

		VALUE		UNIT
		MIN	MAX	
Input voltage ⁽²⁾	VBST1, VBST2	-0.3	32	V
	VBST1, VBST2 ⁽³⁾	-0.3	6	
	SW1, SW2	-6.0	26	
	VIN	-0.3	26	
	EN1, EN2	-0.3	6	
	VFB1, VFB2	-0.3	3.6	
	VO1	-0.3	6	
Output voltage ⁽²⁾	DRVH1, DRVH2	-6.0	32	V
	DRVH1, DRVH2 ⁽³⁾	-0.3	6	
	DRVH1, DRVH2 ⁽³⁾ (pulse width < 20 ns)	-2.5	6	
	DRVL1, DRVL2	-0.3	6	
	DRVL1, DRVL2 (pulse width < 20 ns)	-2.5	6	
	PGOOD, VCLK, VREG5	-0.3	6	
	VREG3, CS1, CS2	-0.3	3.6	
Electrostatic discharge	HBM QSS 009-105 (JESD22-A114A)		2	kV
	CDM QSS 009-147 (JESD22-C101B.01)		1	
Junction temperature, T _J		150		°C
Storage temperature, T _{ST}		-55	150	°C

- (1) Stresses beyond those listed under "absolute maximum ratings" may cause permanent damage to the device. These are stress ratings only and functional operation of the device at these or any other conditions beyond those indicated under "recommended operating conditions" is not implied. Exposure to absolute-maximum-rated conditions for extended periods may affect device reliability.
- (2) All voltage values are with respect to the network ground terminal unless otherwise noted
- (3) Voltage values are with respect to SW terminals.

THERMAL INFORMATION

THERMAL METRIC ⁽¹⁾		TPS51225 TPS51225B TPS51225C	UNITS
		20-PIN RUK	
θ_{JA}	Junction-to-ambient thermal resistance	94.1	°C/W
$\theta_{Jc\text{top}}$	Junction-to-case (top) thermal resistance	58.1	
θ_{JB}	Junction-to-board thermal resistance	64.3	
ψ_{JT}	Junction-to-top characterization parameter	31.8	
ψ_{JB}	Junction-to-board characterization parameter	58.0	
$\theta_{Jc\text{bot}}$	Junction-to-case (bottom) thermal resistance	5.9	

- (1) For more information about traditional and new thermal metrics, see the *IC Package Thermal Metrics* application report, [SPRA953](#).

TPS51225, TPS51225B, TPS51225C

SLUSAV0B – JANUARY 2012 – REVISED SEPTEMBER 2012

www.ti.com

RECOMMENDED OPERATING CONDITIONS

over operating free-air temperature range (unless otherwise noted)

		MIN	TYP	MAX	UNIT
Supply voltage	VIN	5.5		24	
Input voltage ⁽¹⁾	VBST1, VBST2	-0.1		30	V
	VBST1, VBST2 ⁽²⁾	-0.1		5.5	
	SW1, SW2	-5.5		24	
	EN1, EN2	-0.1		5.5	
	VFB1, VFB2	-0.1		3.5	
	VO1	-0.1		5.5	
Output voltage ⁽¹⁾	DRVH1, DRVH2	-5.5		30	V
	DRVH1, DRVH2 ⁽²⁾	-0.1		5.5	
	DRVL1, DRVL2	-0.1		5.5	
	PGOOD, VCLK, VREG5	-0.1		5.5	
	VREG3, CS1, CS2	-0.1		3.5	
Operating free-air temperature, T _A		-40		85	°C

(1) All voltage values are with respect to the network ground terminal unless otherwise noted.

(2) Voltage values are with respect to the SW terminal.

ELECTRICAL CHARACTERISTICS

over operating free-air temperature range, $V_{VIN} = 12\text{ V}$, $V_{VO1} = 5\text{ V}$, $V_{VFB1} = V_{VFB2} = 2\text{ V}$, $V_{EN1} = V_{EN2} = 3.3\text{ V}$ (unless otherwise noted)

PARAMETER		TEST CONDITION	MIN	TYP	MAX	UNIT
SUPPLY CURRENT						
I_{VIN1}	VIN supply current-1	$T_A = 25^\circ\text{C}$, No load, $V_{VO1} = 0\text{ V}$		860		μA
I_{VIN2}	VIN supply current-2	$T_A = 25^\circ\text{C}$, No load		30		μA
I_{VO1}	VO1 supply current	$T_A = 25^\circ\text{C}$, No load, $V_{VFB1} = V_{VFB2} = 2.05\text{ V}$		900		μA
$I_{VIN(STBY)}$	VIN stand-by current	$T_A = 25^\circ\text{C}$, No load, $V_{VO1} = 0\text{ V}$, $V_{EN1} = V_{EN2} = 0\text{ V}$		95		μA
$I_{VIN(STBY)}$	VIN stand-by current	$T_A = 25^\circ\text{C}$, No load, $V_{VO1} = 0\text{ V}$, $V_{EN1} = V_{EN2} = 0\text{ V}$ (TPS51225C)		180		μA
INTERNAL REFERENCE						
V_{FBx}	VFB regulation voltage	$T_A = 25^\circ\text{C}$	1.99	2.00	2.01	V
			1.98	2.00	2.02	V
VREG5 OUTPUT						
V_{VREG5}	VREG5 output voltage	No load, $V_{VO1} = 0\text{ V}$, $T_A = 25^\circ\text{C}$	4.9	5.0	5.1	V
		$V_{VIN} > 7\text{ V}$, $V_{VO1} = 0\text{ V}$, $I_{VREG5} < 100\text{ mA}$	4.85	5.00	5.10	
		$V_{VIN} > 5.5\text{ V}$, $V_{VO1} = 0\text{ V}$, $I_{VREG5} < 35\text{ mA}$	4.85	5.00	5.10	
I_{VREG5}	VREG5 current limit	$V_{VIN} = 7\text{ V}$, $V_{VO1} = 0\text{ V}$, $V_{VREG5} = 4.5\text{ V}$	100	150		mA
R_{V5SW}	5-V switch resistance	$V_{VO1} = 5\text{ V}$, $I_{VREG5} = 50\text{ mA}$, $T_A = 25^\circ\text{C}$		1.8		Ω
VREG3 OUTPUT						
V_{VREG3}	VREG3 output voltage	No load, $V_{VO1} = 0\text{ V}$, $T_A = 25^\circ\text{C}$	3.267	3.300	3.333	V
		$V_{VIN} > 7\text{ V}$, $V_{VO1} = 0\text{ V}$, $I_{VREG3} < 100\text{ mA}$	3.217	3.300	3.383	
		$5.5\text{ V} < V_{VIN}$, $V_{VO1} = 0\text{ V}$, $I_{VREG3} < 35\text{ mA}$	3.234	3.300	3.366	
		$V_{VIN} > 5.5\text{ V}$, $V_{VO1} = 0\text{ V}$, $I_{VREG3} < 35\text{ mA}$, $0^\circ\text{C} \leq T_A \leq 85^\circ\text{C}$	3.267	3.300	3.333	
		$V_{VIN} > 5.5\text{ V}$, $V_{VO1} = 5\text{ V}$, $I_{VREG3} < 35\text{ mA}$, $0^\circ\text{C} \leq T_A \leq 85^\circ\text{C}$	3.267	3.300	3.333	
I_{VREG3}	VREG3 current limit	$V_{VO1} = 0\text{ V}$, $V_{VREG3} = 3.0\text{ V}$, $V_{VIN} = 7\text{ V}$	100	150		mA
DUTY CYCLE and FREQUENCY CONTROL						
f_{SW1}	CH1 frequency ⁽¹⁾	$T_A = 25^\circ\text{C}$, $V_{VIN} = 20\text{ V}$	240	300	360	kHz
f_{SW2}	CH2 frequency ⁽¹⁾	$T_A = 25^\circ\text{C}$, $V_{VIN} = 20\text{ V}$	280	355	430	kHz
$t_{OFF(MIN)}$	Minimum off-time	$T_A = 25^\circ\text{C}$	200	300	500	ns
MOSFET DRIVERS						
R_{DRVH}	DRVH resistance	Source, $(V_{VBST} - V_{DRVH}) = 0.25\text{ V}$, $(V_{VBST} - V_{SW}) = 5\text{ V}$		3.0		Ω
		Sink, $(V_{DRVH} - V_{SW}) = 0.25\text{ V}$, $(V_{VBST} - V_{SW}) = 5\text{ V}$		1.9		
R_{DRVL}	DRVL resistance	Source, $(V_{VREG5} - V_{DRVL}) = 0.25\text{ V}$, $V_{VREG5} = 5\text{ V}$		3.0		Ω
		Sink, $V_{DRVL} = 0.25\text{ V}$, $V_{VREG5} = 5\text{ V}$		0.9		
t_D	Dead time	DRVH-off to DRVL-on		12		ns
		DRVL-off to DRVH-on		20		
INTERNAL BOOT STRAP SWITCH						
$R_{VBST(ON)}$	Boost switch on-resistance	$T_A = 25^\circ\text{C}$, $I_{VBST} = 10\text{ mA}$		13		Ω
I_{VBSTLK}	VBST leakage current	$T_A = 25^\circ\text{C}$			1	μA
CLOCK OUTPUT						
$R_{VCLK(PU)}$	VCLK on-resistance (pull-up)	$T_A = 25^\circ\text{C}$		10		Ω
$R_{VCLK(PD)}$	VCLK on-resistance (pull-down)	$T_A = 25^\circ\text{C}$		10		
f_{CLK}	Clock frequency	$T_A = 25^\circ\text{C}$		260		kHz

(1) Ensured by design. Not production tested.

ELECTRICAL CHARACTERISTICS

over operating free-air temperature range, $V_{VIN} = 12\text{ V}$, $V_{VO1} = 5\text{ V}$, $V_{VFB1} = V_{VFB2} = 2\text{ V}$, $V_{EN1} = V_{EN2} = 3.3\text{ V}$ (unless otherwise noted)

PARAMETER		TEST CONDITION	MIN	TYP	MAX	UNIT
OUTPUT DISCHARGE						
R_{DIS1}	CH1 discharge resistance	$T_A = 25^\circ\text{C}$, $V_{VO1} = 0.5\text{ V}$ $V_{EN1} = V_{EN2} = 0\text{ V}$		35		Ω
R_{DIS2}	CH2 discharge resistance	$T_A = 25^\circ\text{C}$, $V_{SW2} = 0.5\text{ V}$ $V_{EN1} = V_{EN2} = 0\text{ V}$		75		Ω
R_{DIS2}	CH2 discharge resistance	$T_A = 25^\circ\text{C}$, $V_{SW2} = 0.5\text{ V}$, $V_{EN1} = V_{EN2} = 0\text{ V}$ (TPS51225C)		70		Ω
SOFT START OPERATION						
t_{SS}	Soft-start time	From ENx="Hi" and $V_{VREG5} > V_{UVLO5}$ to $V_{OUT} = 95\%$		0.91		ms
t_{SSRAMP}	Soft-start time (ramp-up)	$V_{OUT} = 0\%$ to $V_{OUT} = 95\%$, $V_{VREG5} = 5\text{ V}$		0.78		ms
POWER GOOD						
V_{PGTH}	PG threshold	Lower (rising edge of PG-in)	92.5%	95.0%	97.5%	
		Hysteresis		5%		
		Upper (rising edge of PG-out)	107.5%	110.0%	112.5%	
		Hysteresis		5%		
I_{PGMAX}	PG sink current	$V_{PGOOD} = 0.5\text{ V}$		6.5		mA
I_{PGLK}	PG leak current	$V_{PGOOD} = 5.5\text{ V}$			1	μA
t_{PGDEL}	PG delay	From PG lower threshold (95%=typ) to PG flag high		0.7		ms
CURRENT SENSING						
I_{CS}	CS source current	$T_A = 25^\circ\text{C}$, $V_{CS} = 0.4\text{ V}$	9	10	11	μA
TC_{CS}	CS current temperature coefficient ⁽¹⁾	On the basis of 25°C		4500		ppm/ $^\circ\text{C}$
V_{CS}	CS Current limit setting range		0.2		2	V
V_{ZC}	Zero cross detection offset	$T_A = 25^\circ\text{C}$	-1	1	3	mV
LOGIC THRESHOLD						
$V_{ENX(ON)}$	EN threshold high-level	SMPS on level			1.6	V
$V_{ENX(OFF)}$	EN threshold low-level	SMPS off level	0.3			V
I_{EN}	EN input current	$V_{ENx} = 3.3\text{ V}$	-1		1	μA
OUTPUT OVERVOLTAGE PROTECTION						
V_{OVP}	OVP trip threshold		112.5%	115.0%	117.5%	
t_{OVPDLY}	OVP propagation delay	$T_A = 25^\circ\text{C}$		0.5		μs
OUTPUT UNDERVOLTAGE PROTECTION						
V_{UVP}	UVP trip Threshold		55%	60%	65%	
t_{UVPDLY}	UVP prop delay			250		μs
$t_{UVPENDLY}$	UVP enable delay	From ENx ="Hi", $V_{VREG5} = 5\text{ V}$		1.35		ms
UVLO						
$V_{UVLOVIN}$	VIN UVLO Threshold	Wake up		4.58		V
		Hysteresis		0.5		V
V_{UVLO5}	VREG5 UVLO Threshold	Wake up		4.38		V
		Hysteresis		0.4		V
V_{UVLO3}	VREG3 UVLO Threshold	Wake up		3.15		V
		Hysteresis		0.15		V
OVER TEMPERATURE PROTECTION						
T_{OTP}	OTP threshold ⁽¹⁾	Shutdown temperature		155		$^\circ\text{C}$
		Hysteresis		10		

(1) Ensured by design. Not production tested.

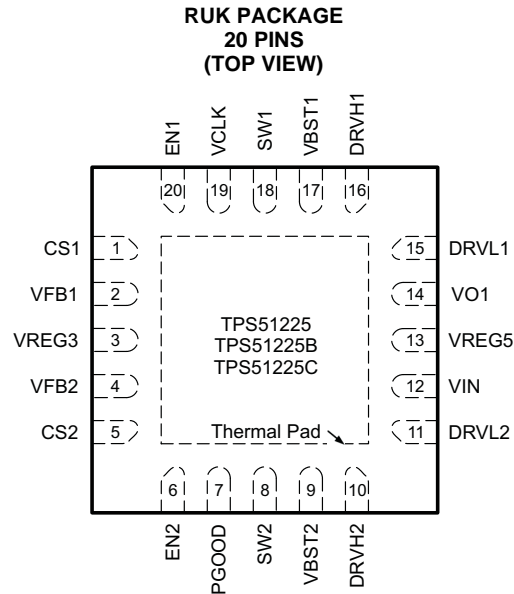
DEVICE INFORMATION

PIN FUNCTIONS

NAME	PIN NO.	I/O	DESCRIPTION
	TPS51225 TPS51225B TPS51225C		
CS1	1	O	Sets the channel 1 OCL trip level.
CS2	5	O	Sets the channel 2 OCL trip level.
DRVH1	16	O	High-side driver output
DRVH2	10	O	High-side driver output
DRVL1	15	O	Low-side driver output
DRVL2	11	O	Low-side driver output
EN1	20	I	Channel 1 enable.
EN2	6	I	Channel 2 enable.
PGOOD	7	O	Power good output flag. Open drain output. Pull up to external rail via a resistor
SW1	18	O	Switch-node connection.
SW2	8	O	Switch-node connection.
VBST1	17	I	Supply input for high-side MOSFET (bootstrap terminal). Connect capacitor from this pin to SW terminal.
VBST2	9	I	
VCLK	19	O	Clock output for charge pump.
VFB1	2	I	Voltage feedback Input
VFB2	4	I	
VIN	12	I	Power conversion voltage input. Apply the same voltage as drain voltage of high-side MOSFETs of channel 1 and channel 2.
VO1	14	I	Output voltage input, 5-V input for switch-over.
VREG3	3	O	3.3-V LDO output.
VREG5	13	O	5-V LDO output.
Thermal pad	—	—	GND terminal, solder to the ground plane

TPS51225, TPS51225B, TPS51225C

SLUSAV0B – JANUARY 2012 – REVISED SEPTEMBER 2012

www.ti.com

FUNCTIONAL BLOCK DIAGRAM (TPS51225/B/C)

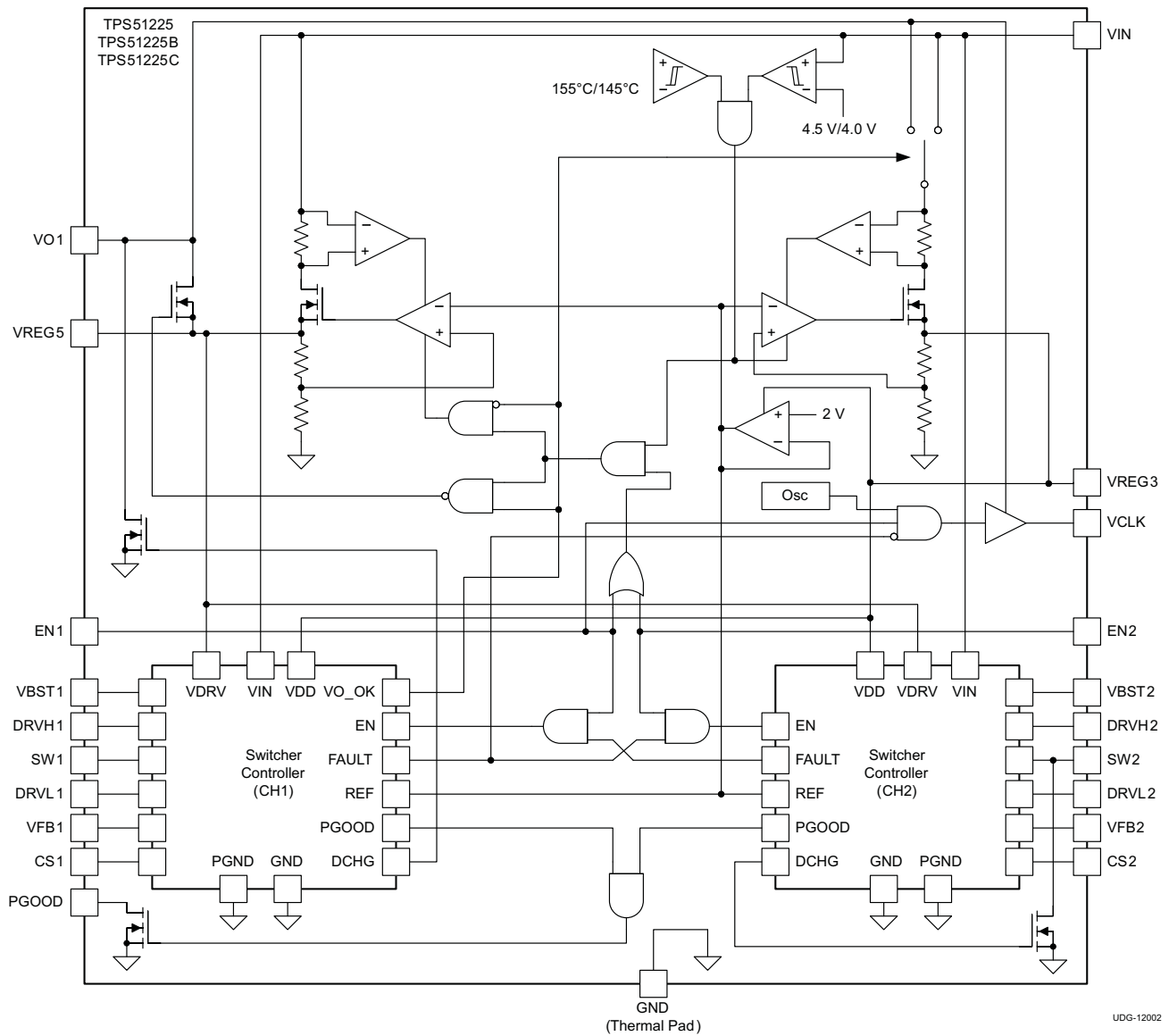

UDG-12002

SWITCHER CONTROLLER BLOCK DIAGRAM

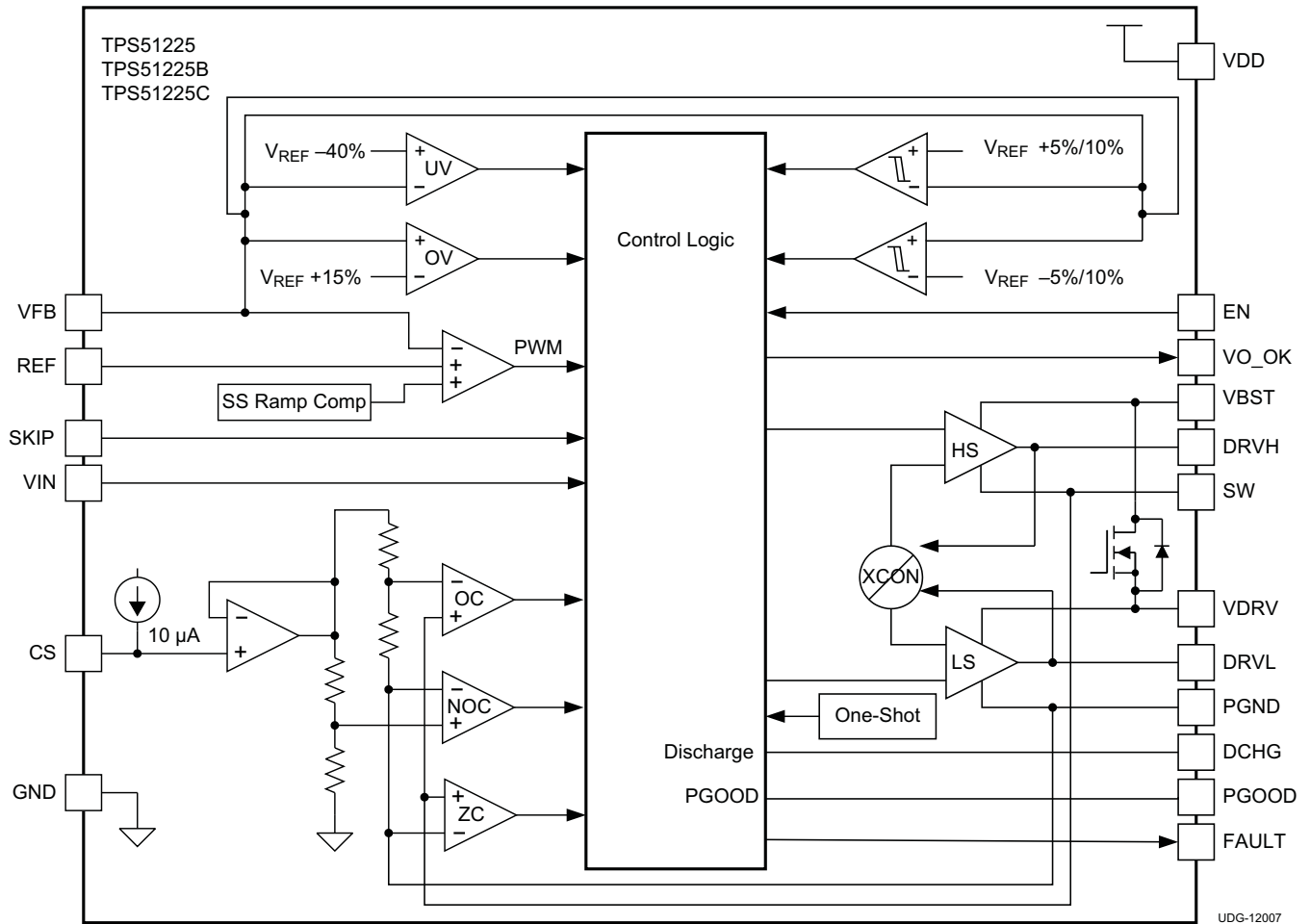

DETAILED DESCRIPTION

PWM Operations

The main control loop of the switch mode power supply (SMPS) is designed as an adaptive on-time pulse width modulation (PWM) controller. It supports a proprietary D-CAP™ mode. D-CAP™ mode does not require external compensation circuit and is suitable for low external component count configuration when used with appropriate amount of ESR at the output capacitor(s).

At the beginning of each cycle, the synchronous high-side MOSFET is turned on, or enters the ON state. This MOSFET is turned off, or enters the 'OFF state, after the internal, one-shot timer expires. The MOSFET is turned on again when the feedback point voltage, V_{VFB} , decreased to match the internal 2-V reference. The inductor current information is also monitored and should be below the overcurrent threshold to initiate this new cycle. By repeating the operation in this manner, the controller regulates the output voltage. The synchronous low-side (rectifying) MOSFET is turned on at the beginning of each OFF state to maintain a minimum of conduction loss. The low-side MOSFET is turned off before the high-side MOSFET turns on at next switching cycle or when inductor current information detects zero level. This enables seamless transition to the reduced frequency operation during light-load conditions so that high efficiency is maintained over a broad range of load current.

Adaptive On-Time/ PWM Frequency Control

Because the TPS51225/B/C does not have a dedicated oscillator for control loop on board, switching cycle is controlled by the adaptive on-time circuit. The on-time is controlled to meet the target switching frequency by feed-forwarding the input and output voltage into the on-time one-shot timer. The target switching frequency is varied according to the input voltage to achieve higher duty operation for lower input voltage application. The switching frequency of CH1 (5-V output) is 300 kHz during continuous conduction mode (CCM) operation when $V_{IN} = 20$ V. The CH2 (3.3-V output) is 355 kHz during CCM when $V_{IN} = 20$ V.

Light Load Condition in Auto-Skip Operation (TPS51225/C)

The TPS51225/C automatically reduces switching frequency during light-load conditions to maintain high efficiency. This reduction of frequency is achieved smoothly and without an increase in output voltage ripple. A more detailed description of this operation is as follows. As the output current decreases from heavy-load condition, the inductor current is also reduced and eventually approaches valley zero current, which is the boundary between continuous conduction mode and discontinuous conduction mode. The rectifying MOSFET is turned off when this zero inductor current is detected. As the load current further decreases, the converter runs in discontinuous conduction mode and it takes longer and longer to discharge the output capacitor to the level that requires the next ON cycle. The ON time is maintained the same as that in the heavy-load condition. In reverse, when the output current increase from light load to heavy load, the switching frequency increases to the preset value as the inductor current reaches to the continuous conduction. The transition load point to the light load operation $I_{OUT(LL)}$ (i.e. the threshold between continuous and discontinuous conduction mode) can be calculated as shown in [Equation 1](#).

$$I_{OUT(LL)} = \frac{1}{2 \times L \times f_{SW}} \times \frac{(V_{IN} - V_{OUT}) \times V_{OUT}}{V_{IN}}$$

where

- f_{SW} is the PWM switching frequency (1)

Switching frequency versus output current during light-load conditions is a function of inductance (L), input voltage (V_{IN}) and output voltage (V_{OUT}), but it decreases almost proportional to the output current from the $I_{OUT(LL)}$.

Light-Load Condition in Out-of-Audio™ Operation (TPS51225B)

Out-of-Audio™ (OOA) light-load mode is a unique control feature that keeps the switching frequency above acoustic audible frequencies toward a virtual no-load condition. During Out-of-Audio™ operation, the OOA control circuit monitors the states of both MOSFETs and forces them to transition into the ON state if both of MOSFETs are off for more than 40 μs. When both high-side and low-side MOSFETs are off for 40 μs during a light-load condition, the operation mode is changed to FCCM. This mode change initiates the low-side MOSFET on and pulls down the output voltage. Then, the high-side MOSFET is turned on and stops switching again.

Table 1. SKIP Mode Operation (TPS51225/B/C)

	SKIP MODE OPERATION
TPS51225	Auto-skip
TPS51225B	OOA
TPS51225C	Auto-skip

D-CAP™ Mode

From small-signal loop analysis, a buck converter using D-CAP™ mode can be simplified as shown in [Figure 1](#).

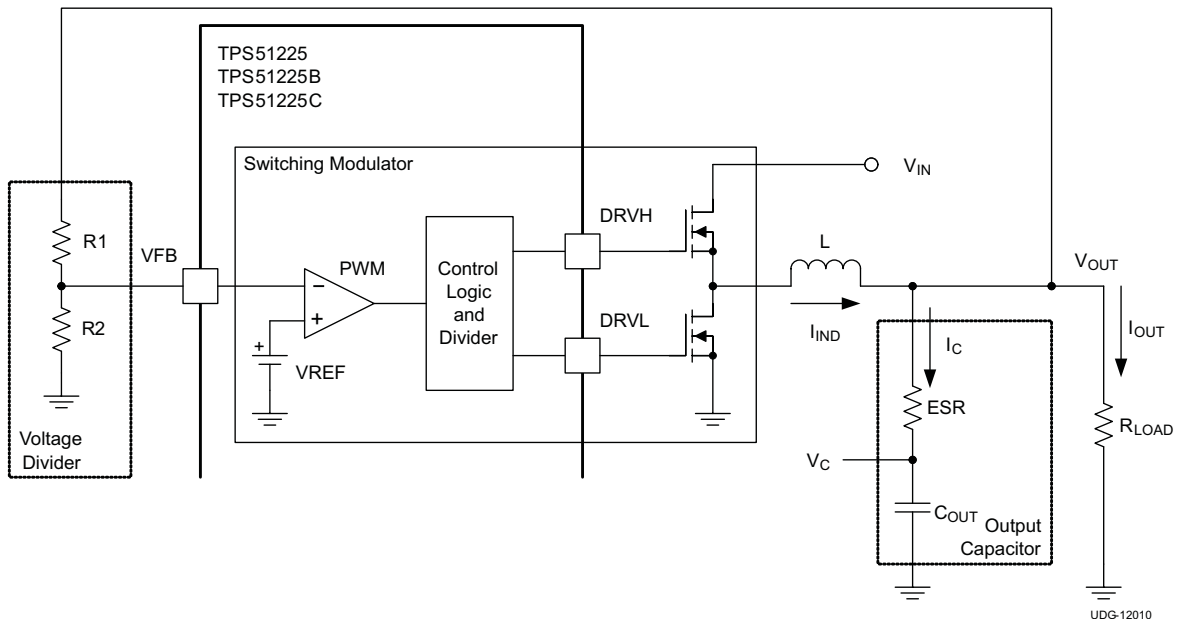

Figure 1. Simplifying the Modulator

The output voltage is compared with internal reference voltage after divider resistors, R1 and R2. The PWM comparator determines the timing to turn on the high-side MOSFET. The gain and speed of the comparator is high enough to keep the voltage at the beginning of each ON cycle substantially constant. For the loop stability, the 0dB frequency, f_0 , defined in [Equation 2](#) must be lower than 1/4 of the switching frequency.

$$f_0 = \frac{1}{2\pi \times \text{ESR} \times C_{\text{OUT}}} \leq \frac{f_{\text{SW}}}{4} \quad (2)$$

As f_0 is determined solely by the output capacitor characteristics, the loop stability during D-CAP™ mode is determined by the capacitor chemistry. For example, specialty polymer capacitors have output capacitance in the order of several hundred micro-Farads and ESR in range of 10 milli-ohms. These yield an f_0 value on the order of 100 kHz or less and the loop is stable. However, ceramic capacitors have f_0 at more than 700 kHz, which is not suitable for this operational mode.

TPS51225, TPS51225B, TPS51225C

SLUSAV0B – JANUARY 2012 – REVISED SEPTEMBER 2012

www.ti.com

Enable and Powergood

VREG3 is an always-on regulator (TPS51225/B), VREG3/VREG5 are always-on regulators (TPS51225C), when the input voltage is beyond the UVLO threshold it turns ON. VREG5 is turned ON when either EN1 or EN2 enters the ON state. The VCLK signal initiates when EN1 enters the ON state (TPS51225/B/C). Enable states are shown in Table 2 through Table 3.

Table 2. Enabling/PGOOD State (TPS51225/B)

EN1	EN2	VREG5	VREG3	CH1 (5Vout)	CH2 (3.3Vout)	VCLK	PGOOD
OFF	OFF	OFF	ON	OFF	OFF	OFF	Low
ON	OFF	ON	ON	ON	OFF	ON	Low
OFF	ON	ON	ON	OFF	ON	OFF	Low
ON	ON	ON	ON	ON	ON	ON	High

Table 3. Enabling/PGOOD State (TPS51225C)

EN1	EN2	VREG5	VREG3	CH1 (5Vout)	CH2 (3.3Vout)	VCLK	PGOOD
OFF	OFF	ON	ON	OFF	OFF	OFF	Low
ON	OFF	ON	ON	ON	OFF	ON	Low
OFF	ON	ON	ON	OFF	ON	OFF	Low
ON	ON	ON	ON	ON	ON	ON	High

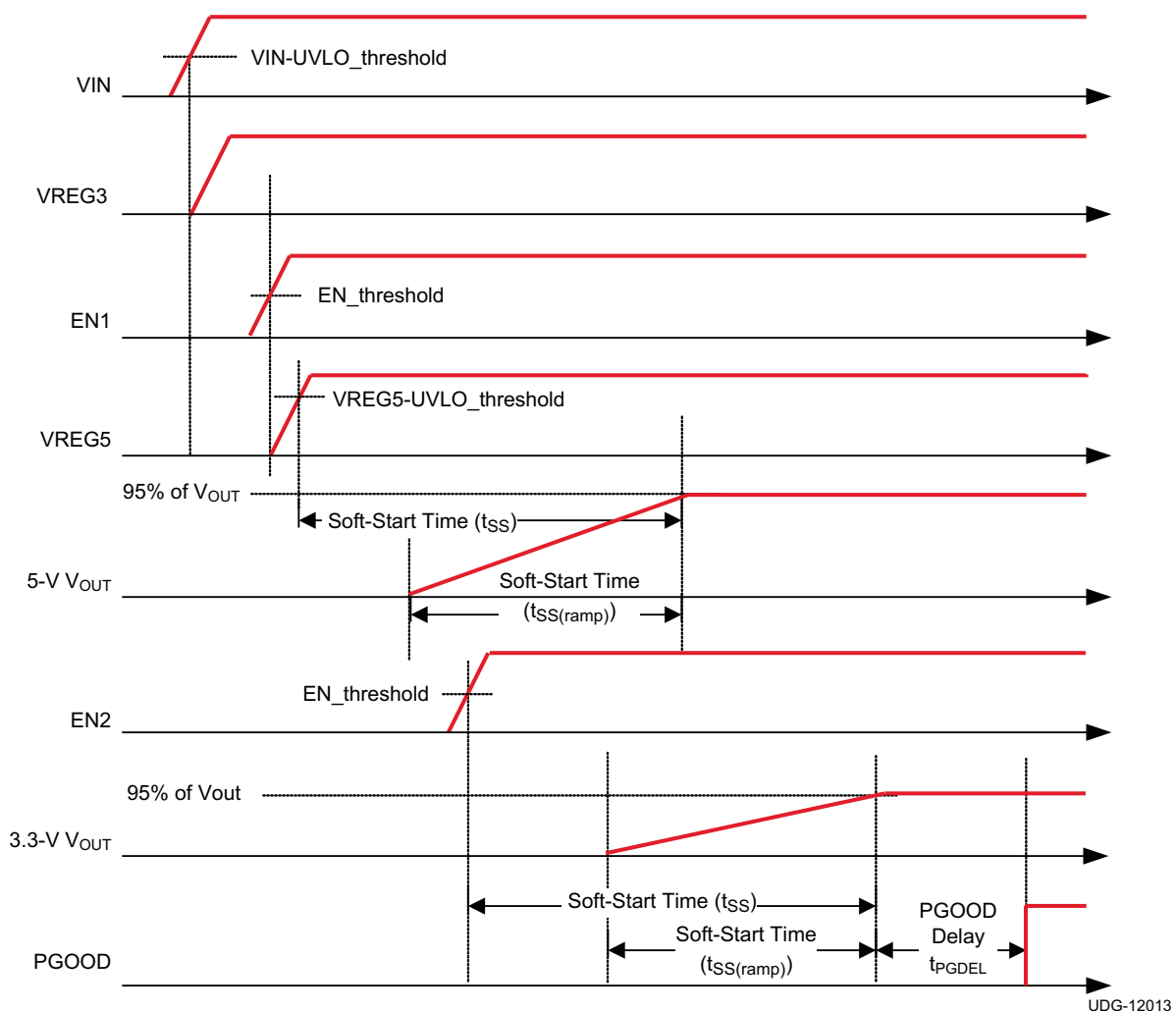

Figure 2. TPS51225 and TPS51225B Timing

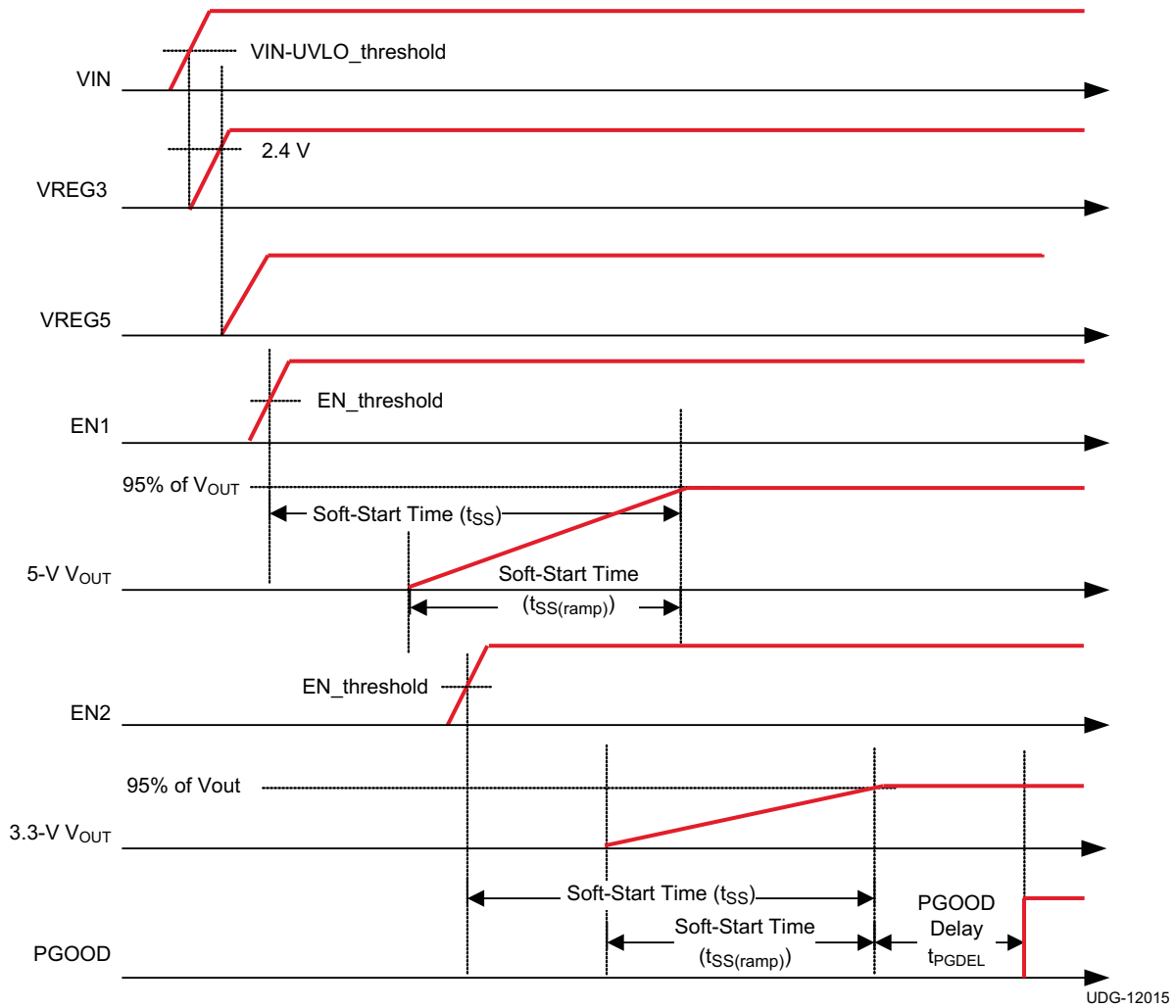

Figure 3. TPS51225C Timing

UDG-12015

Soft-Start and Discharge

The TPS51225/B/C operates an internal, 0.8-ms, voltage servo soft-start for each channel. When the ENx pin becomes higher than the enable threshold voltage, an internal DAC begins ramping up the reference voltage to the PWM comparator. Smooth control of the output voltage is maintained during start-up. When ENx becomes lower than the lower level of threshold voltage, TPS51225/B/C discharges outputs using internal MOSFETs through VO1 (CH1) and SW2 (CH2).

VREG5/VREG3 Linear Regulators

There are two sets of 100-mA standby linear regulators which output 5 V and 3.3 V, respectively. The VREG5 pin provides the current for the gate drivers. The VREG3 pin functions as the main power supply for the analog circuitry of the device. VREG3 is an *Always ON* LDO and TPS51225C has *Always ON* VREG5. (see [Table 2](#) and [Table 3](#))

Add ceramic capacitors with a value of 1 μ F or larger (X5R grade or better) placed close to the VREG5 and VREG3 pins to stabilize LDOs.

The VREG5 pin switchover function is asserted when three conditions are present:

- CH1 internal PGOOD is high
- CH1 is not in OCL condition
- VO1 voltage is higher than VREG5-1V

In this switchover condition, three things occur:

- the internal 5-V, LDO regulator is shut off
- the VREG5 output is connected to VO1 by internal switchover MOSFET
- VREG3 input pass is changed from VIN to VO1

VCLK for Charge Pump

The 260-kHz VCLK signal can be used in the charge pump circuit. The VCLK signal becomes available when EN1. The VCLK driver is driven by VO1 voltage. In a design that does not require VCLK output, leave the VCLK pin open.

Overcurrent Protection

TPS51225/B/C has cycle-by-cycle over current limiting control. The inductor current is monitored during the OFF state and the controller maintains the OFF state during the inductor current is larger than the overcurrent trip level. In order to provide both good accuracy and cost effective solution, TPS51225/B/C supports temperature compensated MOSFET $R_{DS(on)}$ sensing. The CSx pin should be connected to GND through the CS voltage setting resistor, R_{CS} . The CSx pin sources CS current (I_{CS}) which is 10 μ A typically at room temperature, and the CSx terminal voltage ($V_{CS} = R_{CS} \times I_{CS}$) should be in the range of 0.2 V to 2 V over all operation temperatures.

The trip level is set to the OCL trip voltage (V_{TRIP}) as shown in [Equation 3](#).

$$V_{TRIP} = \frac{R_{CS} \times I_{CS}}{8} + 1 \text{ mV} \quad (3)$$

The inductor current is monitored by the voltage between GND pin and SWx pin so that SWx pin should be connected to the drain terminal of the low-side MOSFET properly. The CS pin current has a 4500 ppm/ $^{\circ}$ C temperature slope to compensate the temperature dependency of the $R_{DS(on)}$. GND is used as the positive current sensing node so that GND should be connected to the source terminal of the low-side MOSFET.

As the comparison is done during the OFF state, V_{TRIP} sets the valley level of the inductor current. Thus, the load current at the overcurrent threshold, I_{OCP} , can be calculated as shown in [Equation 4](#).

$$I_{OCP} = \frac{V_{TRIP}}{R_{DS(on)}} + \frac{I_{IND(ripple)}}{2} = \frac{V_{TRIP}}{R_{DS(on)}} + \frac{1}{2 \times L \times f_{SW}} \times \frac{(V_{IN} - V_{OUT}) \times V_{OUT}}{V_{IN}} \quad (4)$$

In an overcurrent condition, the current to the load exceeds the current to the output capacitor thus the output voltage tends to fall down. Eventually, it ends up with crossing the undervoltage protection threshold and shutdown both channels.

Output Overvoltage/Undervoltage Protection

TPS51225/B/C asserts the overvoltage protection (OVP) when VFBx voltage reaches OVP trip threshold level. When an OVP event is detected, the controller changes the output target voltage to 0 V. This usually turns off DRVH and forces DRVL to be on. When the inductor current begins to flow through the low-side MOSFET and reaches the negative OCL, DRVL is turned off and DRVH is turned on. After the on-time expires, DRVH is turned off and DRVL is turned on again. This action minimizes the output node undershoot due to LC resonance. When the VFBx reaches 0V, the driver output is latched as DRVH off, DRVL on. The undervoltage protection (UVP) latch is set when the VFBx voltage remains lower than UVP trip threshold voltage for 250 μ s or longer. In this fault condition, the controller latches DRVH low and DRVL low and discharges the outputs. UVP detection function is enabled after 1.35 ms of SMPS operation to ensure startup.

Undervoltage Lockout (UVLO) Protection

TPS51225/B/C has undervoltage lock out protection at VIN, VREG5 and VREG3. When each voltage is lower than their UVLO threshold voltage, both SMPS are shut-off. They are non-latch protections.

Over-Temperature Protection

TPS51225/B/C features an internal temperature monitor. If the temperature exceeds the threshold value (typically 155°C), TPS51225/B/C is shut off including LDOs. This is non-latch protection.

External Components Selection

The external components selection is relatively simple for a design using D-CAP™ mode.

Step 1. Determine the Value of R1 and R2

The recommended R2 value is between 10 kΩ and 20 kΩ. Determine R1 using [Equation 5](#).

$$R1 = \frac{(V_{OUT} - 0.5 \times V_{RIPPLE} - 2.0)}{2.0} \times R2 \quad (5)$$

Step 2. Choose the Inductor

The inductance value should be determined to give the ripple current of approximately 1/3 of maximum output current. Larger ripple current increases output ripple voltage, improves signal:noise ratio, and helps ensure stable operation.

$$L = \frac{1}{I_{IND(ripple)} \times f_{SW}} \times \frac{(V_{IN(max)} - V_{OUT}) \times V_{OUT}}{V_{IN(max)}} = \frac{3}{I_{OUT(max)} \times f_{SW}} \times \frac{(V_{IN(max)} - V_{OUT}) \times V_{OUT}}{V_{IN(max)}} \quad (6)$$

The inductor also needs to have low DCR to achieve good efficiency, as well as enough room above peak inductor current before saturation. The peak inductor current can be estimated as shown in [Equation 7](#).

$$I_{IND(peak)} = \frac{V_{TRIP}}{R_{DS(on)}} + \frac{1}{L \times f_{SW}} \times \frac{(V_{IN(max)} - V_{OUT}) \times V_{OUT}}{V_{IN(max)}} \quad (7)$$

Step 3. Choose Output Capacitor(s)

Organic semiconductor capacitor(s) or specialty polymer capacitor(s) are recommended. Determine ESR to meet required ripple voltage above. A quick approximation is as shown in [Equation 8](#).

$$ESR = \frac{V_{OUT} \times 20mV \times (1-D)}{2V \times I_{IND(ripple)}} = \frac{20mV \times L \times f_{SW}}{2V}$$

where

- D as the duty-cycle factor
 - the required output ripple voltage slope is approximately 20 mV per t_{SW} (switching period) in terms of VFB terminal
- (8)

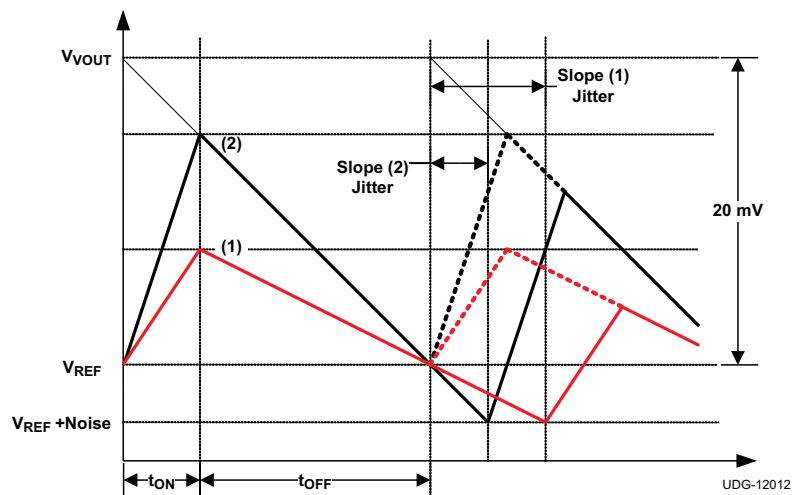

Figure 4. Ripple Voltage Slope and Jitter Performance

Layout Considerations

Good layout is essential for stable power supply operation. Follow these guidelines for an efficient PCB layout.

Placement

- Place voltage setting resistors close to the device pins.
- Place bypass capacitors for VREG5 and VREG3 close to the device pins.

Routing (Sensitive analog portion)

- Use small copper space for VFBx. There are short and narrow traces to avoid noise coupling.
- Connect VFB resistor trace to the positive node of the output capacitor. Routing inner layer away from power traces is recommended.
- Use short and wide trace from VFB resistor to vias to GND (internal GND plane).

Routing (Power portion)

- Use wider/shorter traces of DRV1 for low-side gate drivers to reduce stray inductance.
- Use the parallel traces of SW and DRVH for high-side MOSFET gate drive in a same layer or on adjoint layers, and keep them away from DRV1.
- Use wider/ shorter traces between the source terminal of the high-side MOSFET and the drain terminal of the low-side MOSFET
- Thermal pad is the GND terminal of this device. Five or more vias with 0.33-mm (13-mils) diameter connected from the thermal pad to the internal GND plane should be used to have strong GND connection and help heat dissipation.

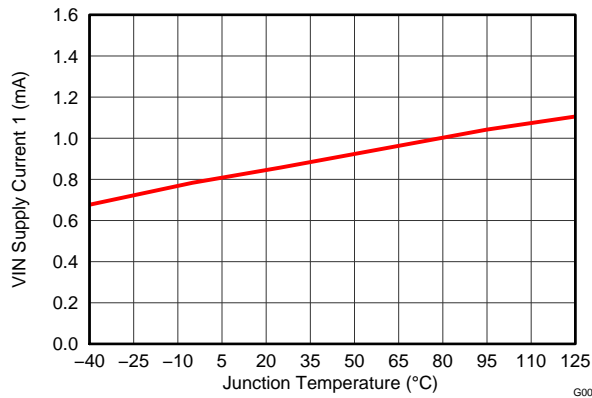
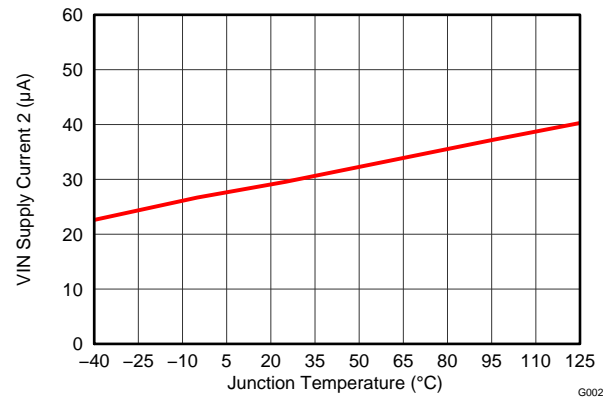
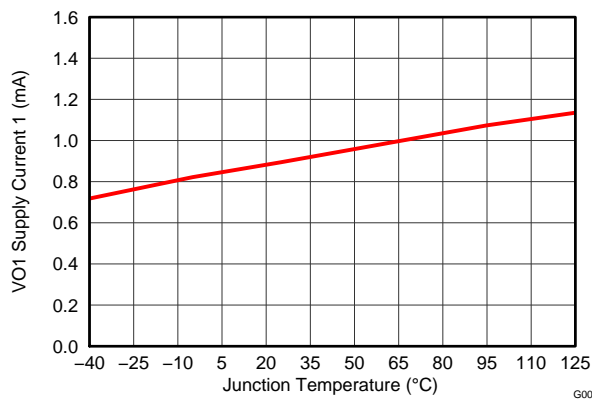
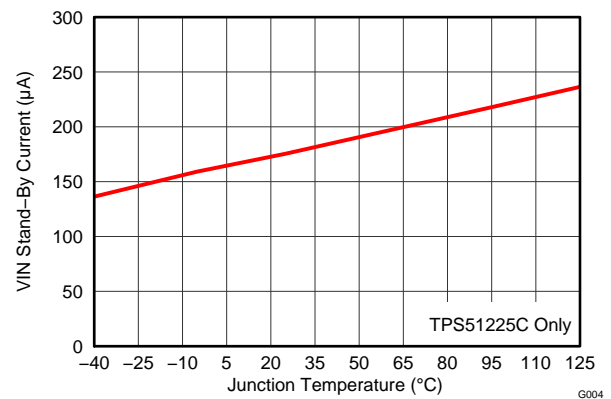
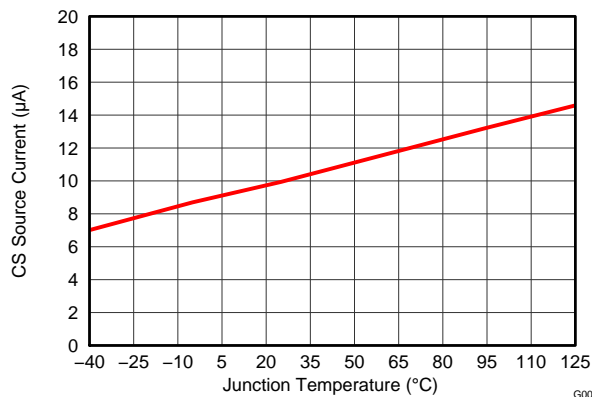
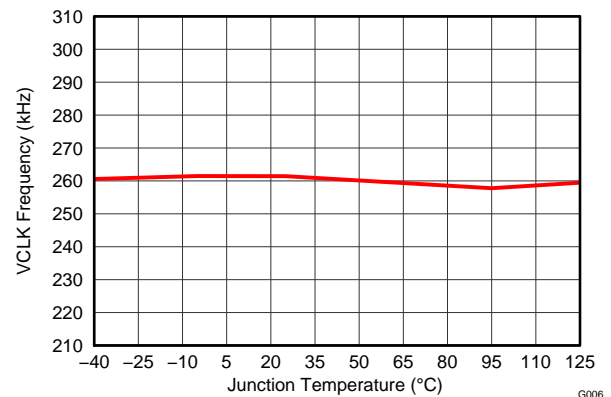
TYPICAL CHARACTERISTICS

Figure 5. VIN Supply Current 1 vs. Junction Temperature

Figure 6. VIN Supply Current 2 vs. Junction Temperature

Figure 7. VO1 Supply Current 1 vs. Junction Temperature

Figure 8. VIN Stand-By Current vs. Junction Temperature

Figure 9. CS Source Current vs. Junction Temperature

Figure 10. Clock Frequency vs. Junction Temperature

TYPICAL CHARACTERISTICS (continued)

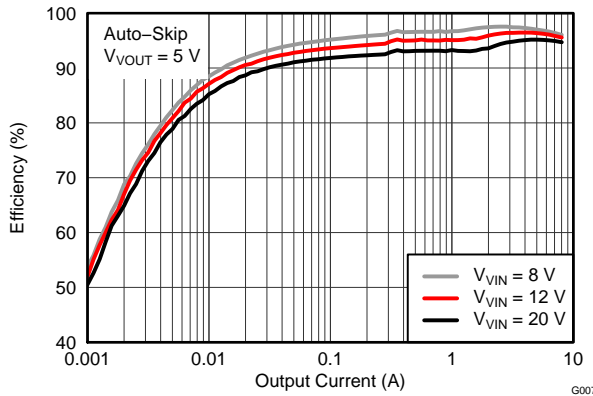

Figure 11. Efficiency vs. Output Current

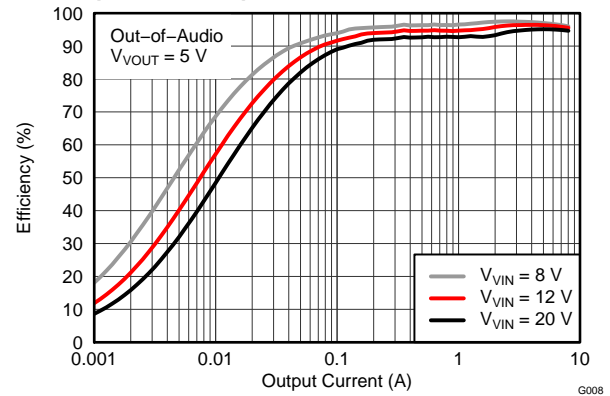

Figure 12. Efficiency vs. Output Current

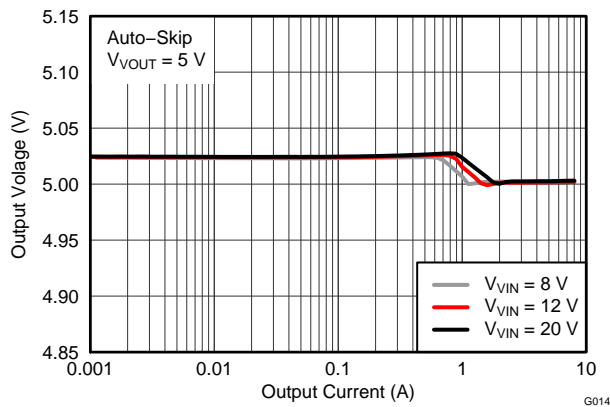

Figure 13. Load Regulation

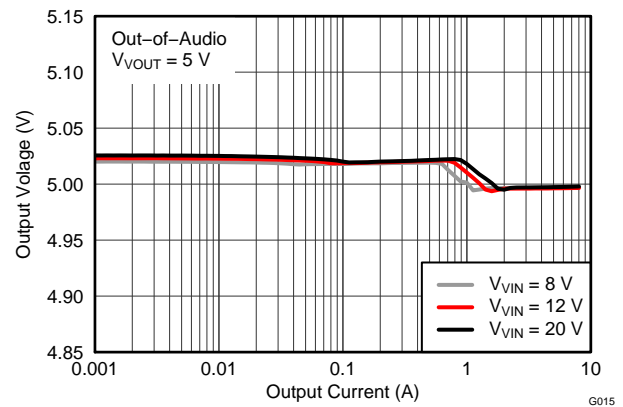

Figure 14. Load Regulation

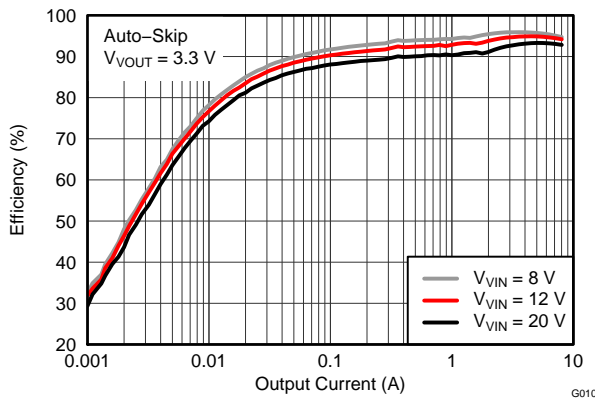

Figure 15. Efficiency vs. Output Current

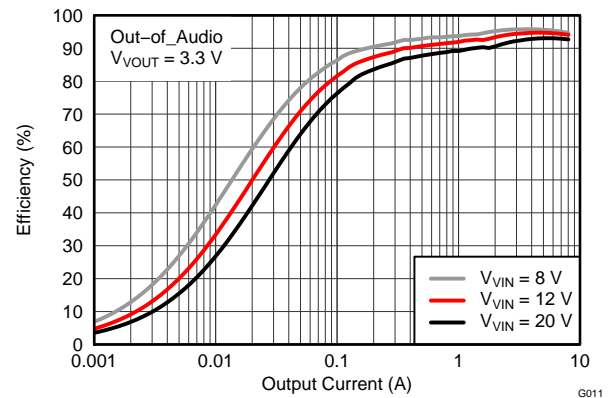

Figure 16. Efficiency vs. Output Current

TYPICAL CHARACTERISTICS (continued)

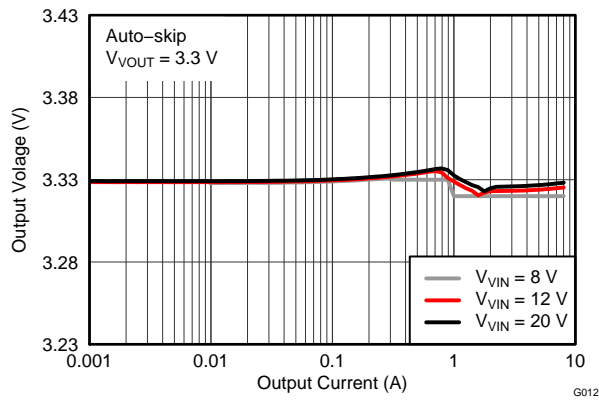

Figure 17. Load Regulation

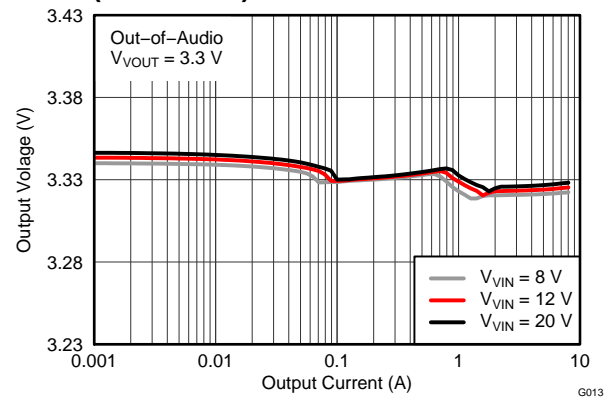

Figure 18. Load Regulation

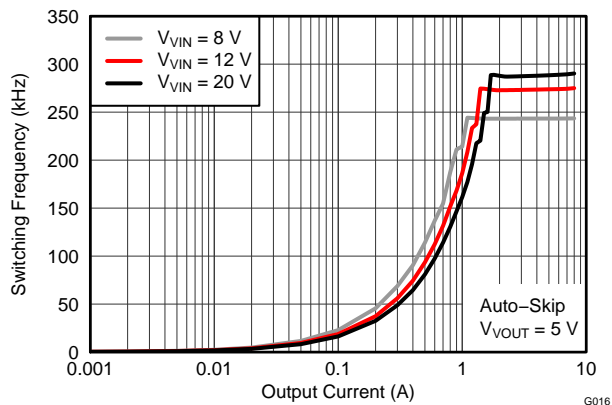

Figure 19. Switching Frequency vs. Output Current

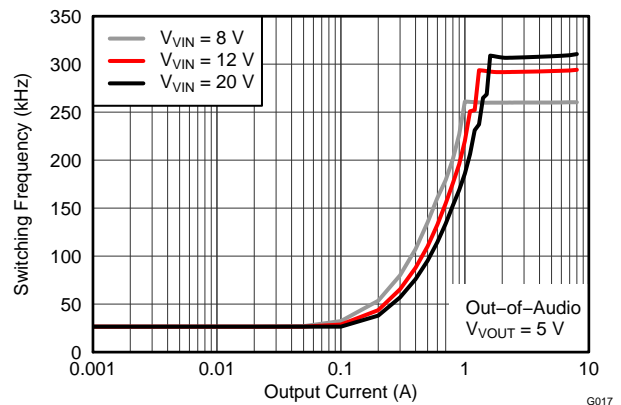

Figure 20. Switching Frequency vs. Output Current

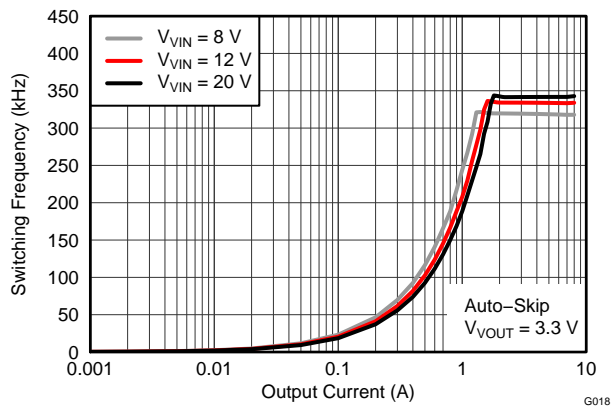

Figure 21. Switching Frequency vs. Output Current

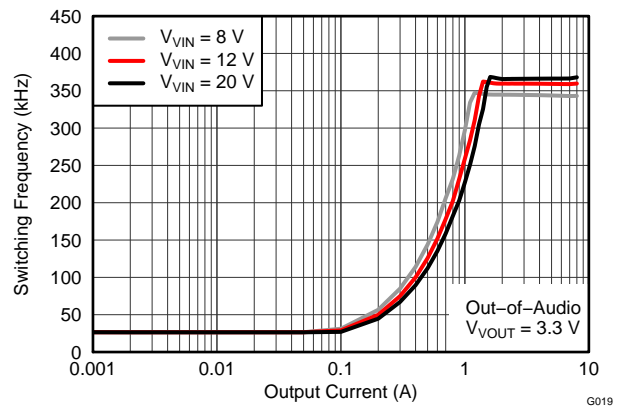

Figure 22. Switching Frequency vs. Output Current

TYPICAL CHARACTERISTICS (continued)

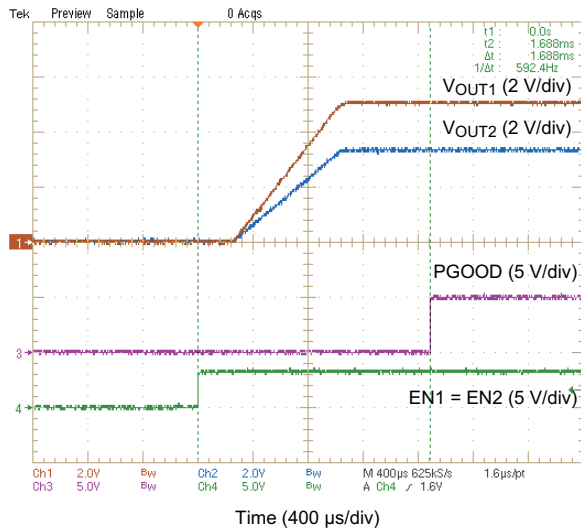

Figure 23. Start-Up

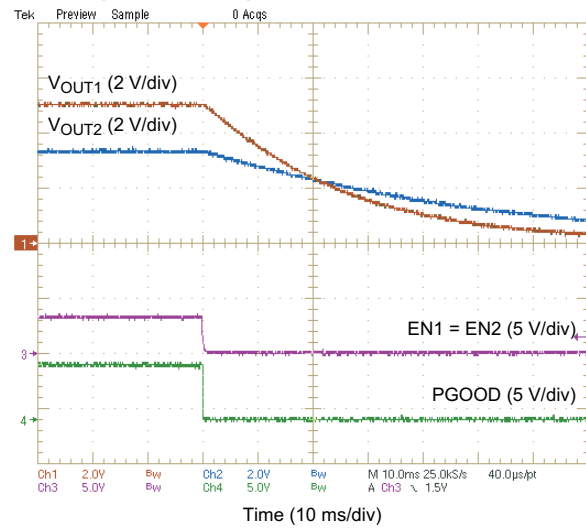

Figure 24. Output Discharge

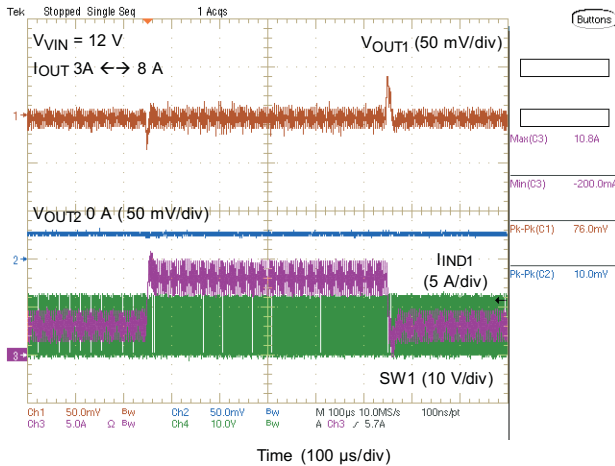

Figure 25. 5-V Load Transient

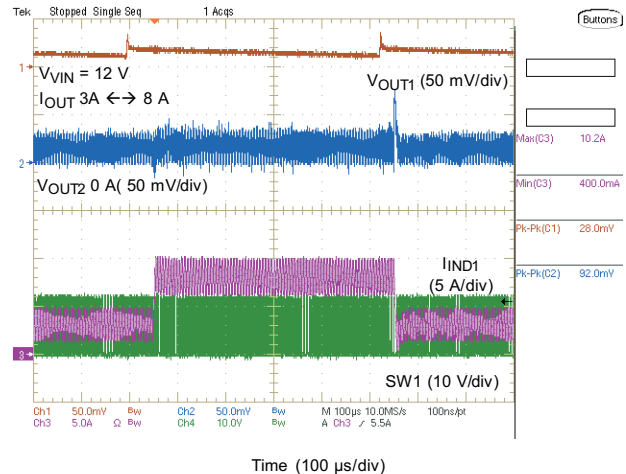

Figure 26. 3.3-V Load Transient

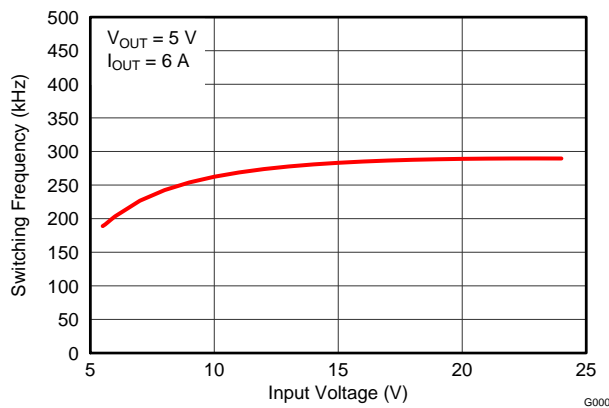

Figure 27. Switching Frequency vs. Input Voltage

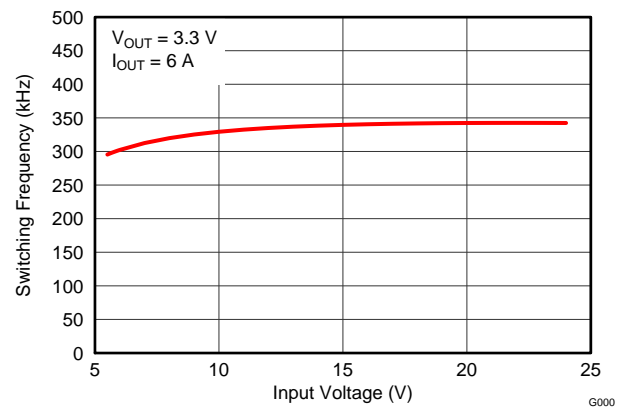

Figure 28. Switching Frequency vs. Input Voltage

TPS51225, TPS51225B, TPS51225C

SLUSAV0B – JANUARY 2012 – REVISED SEPTEMBER 2012

www.ti.com

APPLICATION DIAGRAM (TPS51225/TPS51225B/TPS51225C)

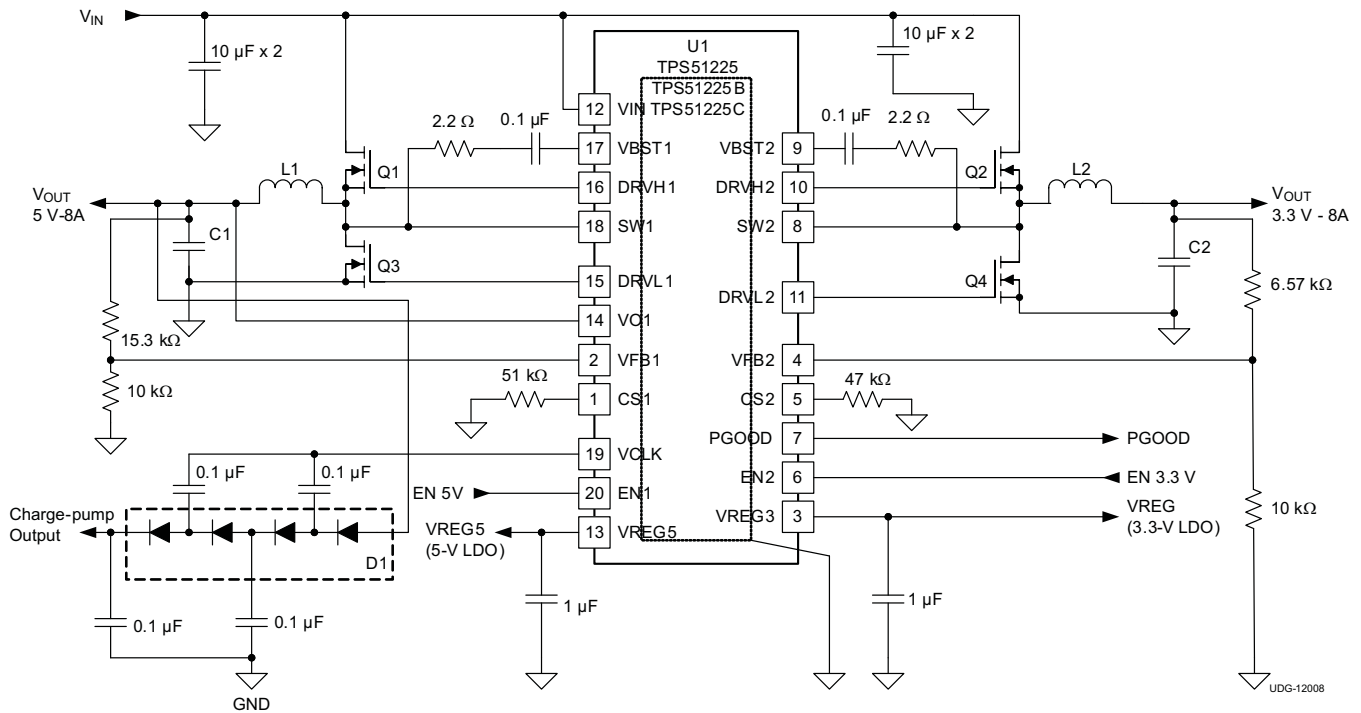

Table 4. Key External Components (APPLICATION DIAGRAM (TPS51225/TPS51225B/TPS51225C))

REFERENCE DESIGNATOR	FUNCTION	MANUFACTURER	PART NUMBER
L1	Output Inductor (5- V_{OUT})	Toko	FDVE1040-3R3M
L2	Output Inductor (3.3- V_{OUT})	Toko	FDVE1040-2R2M
C1	Output Capacitor (5- V_{OUT})	SANYO	6TPE330MIL x 2
C2	Output Capacitor (3.3- V_{OUT})	SANYO	4TPE470MIL
Q1	High-side MOSFET (5- V_{OUT})	Fairchild	FDMC7692
Q2	High-side MOSFET (3.3- V_{OUT})	Fairchild	FDMC7692
Q3	Low-side MOSFET (5- V_{OUT})	Fairchild	FDMC7672
Q4	Low-side MOSFET (3.3- V_{OUT})	Fairchild	FDMC7672

Changes from Original (January 2012) to Revision A**Page**

- Deleted references to obsolete option TPS51225A throughout document 1
-

Changes from Revision A (JUNE 2012) to Revision B**Page**

- Added specification for additional V_{VREG3} output voltage condition in ELECTRICAL CHARACTERISTICS table 5
 - Added clarity to the [VREG5/VREG3 Linear Regulators](#) section. 14
-

PACKAGING INFORMATION

Orderable Device	Status (1)	Package Type	Package Drawing	Pins	Package Qty	Eco Plan (2)	Lead/Ball Finish	MSL Peak Temp (3)	Op Temp (°C)	Top-Side Markings (4)	Samples
TPS51225BRUKR	ACTIVE	WQFN	RUK	20	3000	Green (RoHS & no Sb/Br)	CU NIPDAUAG	Level-2-260C-1 YEAR	-40 to 85	1225B	Samples
TPS51225BRUKT	ACTIVE	WQFN	RUK	20	250	Green (RoHS & no Sb/Br)	CU NIPDAUAG	Level-2-260C-1 YEAR	-40 to 85	1225B	Samples
TPS51225CRUKR	ACTIVE	WQFN	RUK	20	3000	Green (RoHS & no Sb/Br)	CU NIPDAUAG	Level-2-260C-1 YEAR	-40 to 85	1225C	Samples
TPS51225CRUKT	ACTIVE	WQFN	RUK	20	250	Green (RoHS & no Sb/Br)	CU NIPDAUAG	Level-2-260C-1 YEAR	-40 to 85	1225C	Samples
TPS51225RUKR	ACTIVE	WQFN	RUK	20	3000	Green (RoHS & no Sb/Br)	CU NIPDAUAG	Level-2-260C-1 YEAR	-40 to 85	51225	Samples
TPS51225RUKT	ACTIVE	WQFN	RUK	20	250	Green (RoHS & no Sb/Br)	CU NIPDAUAG	Level-2-260C-1 YEAR	-40 to 85	51225	Samples

(1) The marketing status values are defined as follows:

ACTIVE: Product device recommended for new designs.

LIFEBUY: TI has announced that the device will be discontinued, and a lifetime-buy period is in effect.

NRND: Not recommended for new designs. Device is in production to support existing customers, but TI does not recommend using this part in a new design.

PREVIEW: Device has been announced but is not in production. Samples may or may not be available.

OBSOLETE: TI has discontinued the production of the device.

(2) Eco Plan - The planned eco-friendly classification: Pb-Free (RoHS), Pb-Free (RoHS Exempt), or Green (RoHS & no Sb/Br) - please check <http://www.ti.com/productcontent> for the latest availability information and additional product content details.

TBD: The Pb-Free/Green conversion plan has not been defined.

Pb-Free (RoHS): TI's terms "Lead-Free" or "Pb-Free" mean semiconductor products that are compatible with the current RoHS requirements for all 6 substances, including the requirement that lead not exceed 0.1% by weight in homogeneous materials. Where designed to be soldered at high temperatures, TI Pb-Free products are suitable for use in specified lead-free processes.

Pb-Free (RoHS Exempt): This component has a RoHS exemption for either 1) lead-based flip-chip solder bumps used between the die and package, or 2) lead-based die adhesive used between the die and leadframe. The component is otherwise considered Pb-Free (RoHS compatible) as defined above.

Green (RoHS & no Sb/Br): TI defines "Green" to mean Pb-Free (RoHS compatible), and free of Bromine (Br) and Antimony (Sb) based flame retardants (Br or Sb do not exceed 0.1% by weight in homogeneous material)

(3) MSL, Peak Temp. -- The Moisture Sensitivity Level rating according to the JEDEC industry standard classifications, and peak solder temperature.

(4) Multiple Top-Side Markings will be inside parentheses. Only one Top-Side Marking contained in parentheses and separated by a "~" will appear on a device. If a line is indented then it is a continuation of the previous line and the two combined represent the entire Top-Side Marking for that device.

Important Information and Disclaimer: The information provided on this page represents TI's knowledge and belief as of the date that it is provided. TI bases its knowledge and belief on information provided by third parties, and makes no representation or warranty as to the accuracy of such information. Efforts are underway to better integrate information from third parties. TI has taken and continues to take reasonable steps to provide representative and accurate information but may not have conducted destructive testing or chemical analysis on incoming materials and chemicals. TI and TI suppliers consider certain information to be proprietary, and thus CAS numbers and other limited information may not be available for release.

In no event shall TI's liability arising out of such information exceed the total purchase price of the TI part(s) at issue in this document sold by TI to Customer on an annual basis.

TAPE AND REEL INFORMATION

QUADRANT ASSIGNMENTS FOR PIN 1 ORIENTATION IN TAPE

*All dimensions are nominal

Device	Package Type	Package Drawing	Pins	SPQ	Reel Diameter (mm)	Reel Width W1 (mm)	A0 (mm)	B0 (mm)	K0 (mm)	P1 (mm)	W (mm)	Pin1 Quadrant
TPS51225BRUKR	WQFN	RUK	20	3000	330.0	12.4	3.3	3.3	1.1	8.0	12.0	Q2
TPS51225BRUKT	WQFN	RUK	20	250	180.0	12.4	3.3	3.3	1.1	8.0	12.0	Q2
TPS51225CRUKR	WQFN	RUK	20	3000	330.0	12.4	3.3	3.3	1.1	8.0	12.0	Q2
TPS51225CRUKT	WQFN	RUK	20	250	180.0	12.4	3.3	3.3	1.1	8.0	12.0	Q2
TPS51225RUKR	WQFN	RUK	20	3000	330.0	12.4	3.3	3.3	1.1	8.0	12.0	Q2
TPS51225RUKT	WQFN	RUK	20	250	180.0	12.4	3.3	3.3	1.1	8.0	12.0	Q2

TAPE AND REEL BOX DIMENSIONS

*All dimensions are nominal

Device	Package Type	Package Drawing	Pins	SPQ	Length (mm)	Width (mm)	Height (mm)
TPS51225BRUKR	WQFN	RUK	20	3000	367.0	367.0	35.0
TPS51225BRUKT	WQFN	RUK	20	250	210.0	185.0	35.0
TPS51225CRUKR	WQFN	RUK	20	3000	367.0	367.0	35.0
TPS51225CRUKT	WQFN	RUK	20	250	210.0	185.0	35.0
TPS51225RUKR	WQFN	RUK	20	3000	367.0	367.0	35.0
TPS51225RUKT	WQFN	RUK	20	250	210.0	185.0	35.0

RUK (S-PWQFN-N20)

PLASTIC QUAD FLATPACK NO-LEAD

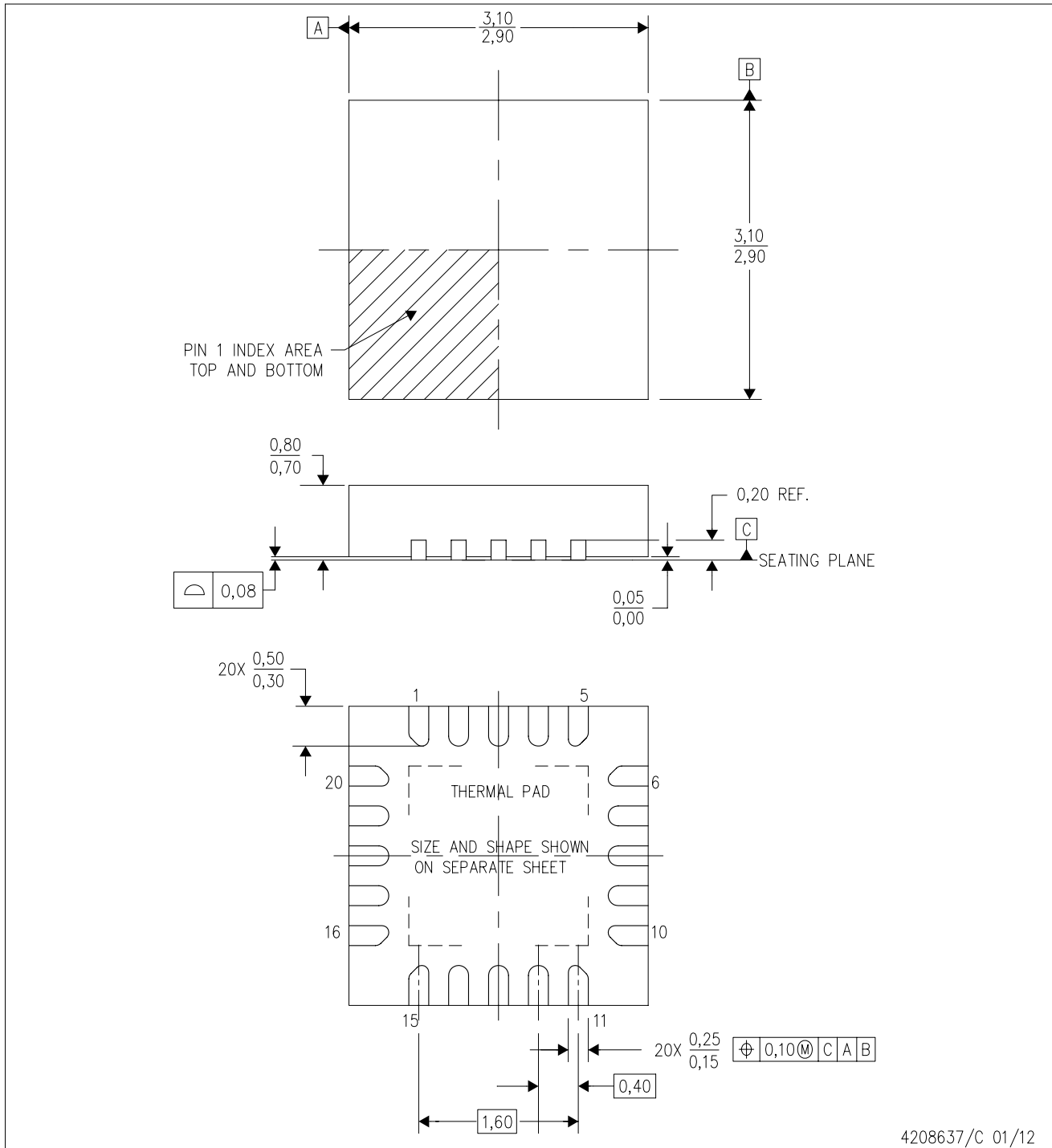

4208637/C 01/12

- NOTES:
- A. All linear dimensions are in millimeters. Dimensioning and tolerancing per ASME Y14.5M-1994.
 - B. This drawing is subject to change without notice.
 - C. Quad Flatpack, No-leads (QFN) package configuration.
 - D. The package thermal pad must be soldered to the board for thermal and mechanical performance.
 - E. See the additional figure in the Product Data Sheet for details regarding the exposed thermal pad features and dimensions.
 - F. Falls within JEDEC MO-220.

RUK (S-PWQFN-N20)

PLASTIC QUAD FLATPACK NO-LEAD

THERMAL INFORMATION

This package incorporates an exposed thermal pad that is designed to be attached directly to an external heatsink. The thermal pad must be soldered directly to the printed circuit board (PCB). After soldering, the PCB can be used as a heatsink. In addition, through the use of thermal vias, the thermal pad can be attached directly to the appropriate copper plane shown in the electrical schematic for the device, or alternatively, can be attached to a special heatsink structure designed into the PCB. This design optimizes the heat transfer from the integrated circuit (IC).

For information on the Quad Flatpack No-Lead (QFN) package and its advantages, refer to Application Report, QFN/SON PCB Attachment, Texas Instruments Literature No. SLUA271. This document is available at www.ti.com.

The exposed thermal pad dimensions for this package are shown in the following illustration.

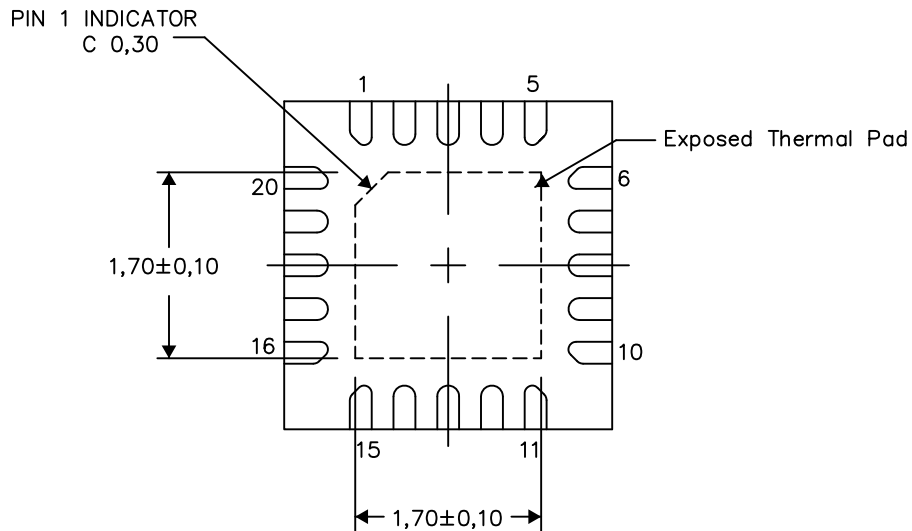

Bottom View

Exposed Thermal Pad Dimensions

4209762/E 12/12

NOTE: All linear dimensions are in millimeters

RUK (S-PWQFN-N20)

PLASTIC QUAD FLATPACK NO-LEAD

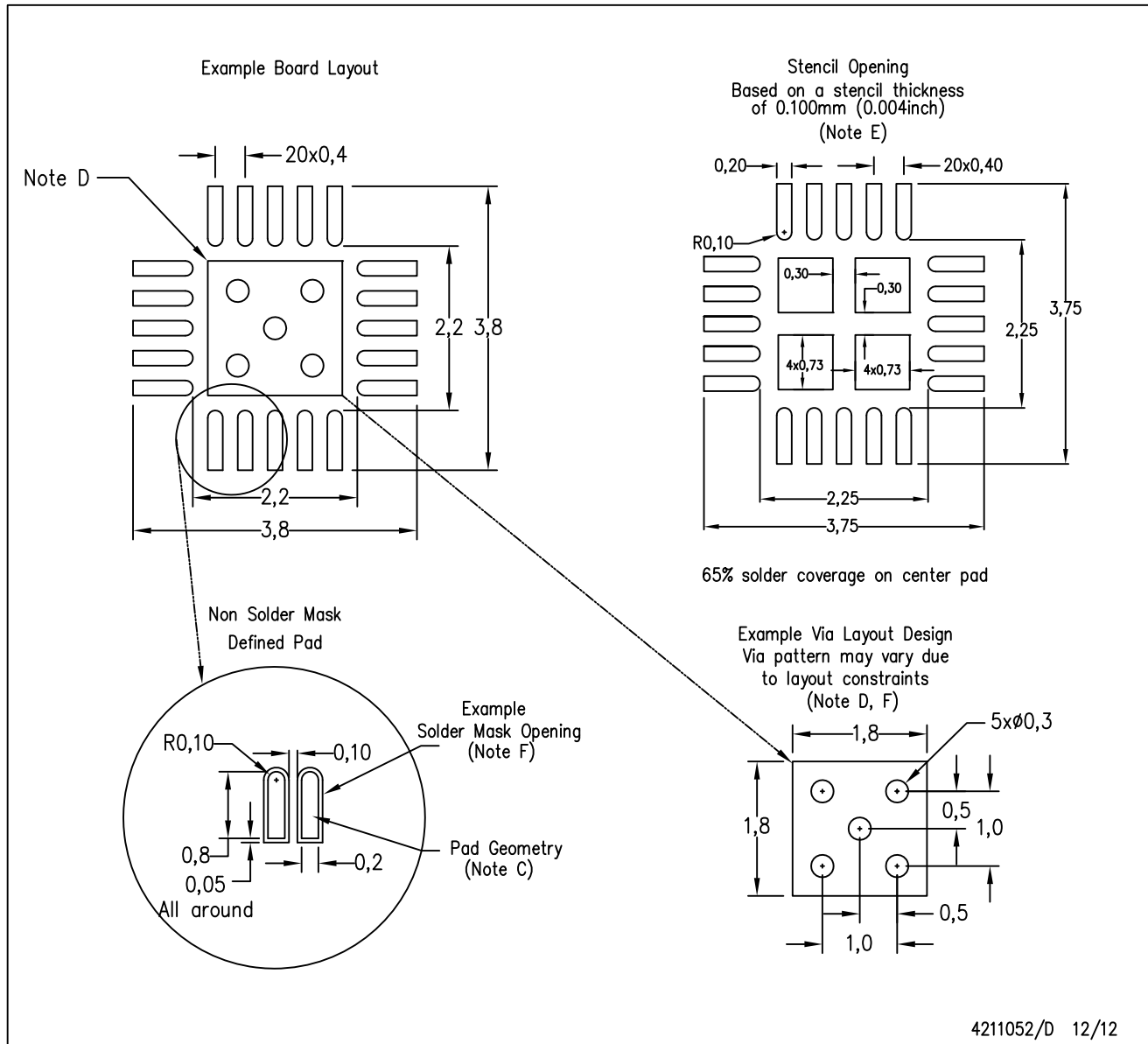

4211052/D 12/12

- NOTES:
- All linear dimensions are in millimeters.
 - This drawing is subject to change without notice.
 - Publication IPC-7351 is recommended for alternate designs.
 - This package is designed to be soldered to a thermal pad on the board. Refer to Application Note, Quad Flat-Pack Packages, Texas Instruments Literature No. SLUA271, and also the Product Data Sheets for specific thermal information, via requirements, and recommended board layout. These documents are available at www.ti.com <<http://www.ti.com>>.
 - Laser cutting apertures with trapezoidal walls and also rounding corners will offer better paste release. Customers should contact their board assembly site for stencil design recommendations. Refer to IPC 7525 for stencil design considerations.
 - Customers should contact their board fabrication site for minimum solder mask web tolerances between signal pads.

IMPORTANT NOTICE

Texas Instruments Incorporated and its subsidiaries (TI) reserve the right to make corrections, enhancements, improvements and other changes to its semiconductor products and services per JESD46, latest issue, and to discontinue any product or service per JESD48, latest issue. Buyers should obtain the latest relevant information before placing orders and should verify that such information is current and complete. All semiconductor products (also referred to herein as "components") are sold subject to TI's terms and conditions of sale supplied at the time of order acknowledgment.

TI warrants performance of its components to the specifications applicable at the time of sale, in accordance with the warranty in TI's terms and conditions of sale of semiconductor products. Testing and other quality control techniques are used to the extent TI deems necessary to support this warranty. Except where mandated by applicable law, testing of all parameters of each component is not necessarily performed.

TI assumes no liability for applications assistance or the design of Buyers' products. Buyers are responsible for their products and applications using TI components. To minimize the risks associated with Buyers' products and applications, Buyers should provide adequate design and operating safeguards.

TI does not warrant or represent that any license, either express or implied, is granted under any patent right, copyright, mask work right, or other intellectual property right relating to any combination, machine, or process in which TI components or services are used. Information published by TI regarding third-party products or services does not constitute a license to use such products or services or a warranty or endorsement thereof. Use of such information may require a license from a third party under the patents or other intellectual property of the third party, or a license from TI under the patents or other intellectual property of TI.

Reproduction of significant portions of TI information in TI data books or data sheets is permissible only if reproduction is without alteration and is accompanied by all associated warranties, conditions, limitations, and notices. TI is not responsible or liable for such altered documentation. Information of third parties may be subject to additional restrictions.

Resale of TI components or services with statements different from or beyond the parameters stated by TI for that component or service voids all express and any implied warranties for the associated TI component or service and is an unfair and deceptive business practice. TI is not responsible or liable for any such statements.

Buyer acknowledges and agrees that it is solely responsible for compliance with all legal, regulatory and safety-related requirements concerning its products, and any use of TI components in its applications, notwithstanding any applications-related information or support that may be provided by TI. Buyer represents and agrees that it has all the necessary expertise to create and implement safeguards which anticipate dangerous consequences of failures, monitor failures and their consequences, lessen the likelihood of failures that might cause harm and take appropriate remedial actions. Buyer will fully indemnify TI and its representatives against any damages arising out of the use of any TI components in safety-critical applications.

In some cases, TI components may be promoted specifically to facilitate safety-related applications. With such components, TI's goal is to help enable customers to design and create their own end-product solutions that meet applicable functional safety standards and requirements. Nonetheless, such components are subject to these terms.

No TI components are authorized for use in FDA Class III (or similar life-critical medical equipment) unless authorized officers of the parties have executed a special agreement specifically governing such use.

Only those TI components which TI has specifically designated as military grade or "enhanced plastic" are designed and intended for use in military/aerospace applications or environments. Buyer acknowledges and agrees that any military or aerospace use of TI components which have **not** been so designated is solely at the Buyer's risk, and that Buyer is solely responsible for compliance with all legal and regulatory requirements in connection with such use.

TI has specifically designated certain components as meeting ISO/TS16949 requirements, mainly for automotive use. In any case of use of non-designated products, TI will not be responsible for any failure to meet ISO/TS16949.

Products

Audio	www.ti.com/audio
Amplifiers	amplifier.ti.com
Data Converters	dataconverter.ti.com
DLP® Products	www.dlp.com
DSP	dsp.ti.com
Clocks and Timers	www.ti.com/clocks
Interface	interface.ti.com
Logic	logic.ti.com
Power Mgmt	power.ti.com
Microcontrollers	microcontroller.ti.com
RFID	www.ti-rfid.com
OMAP Applications Processors	www.ti.com/omap
Wireless Connectivity	www.ti.com/wirelessconnectivity

Applications

Automotive and Transportation	www.ti.com/automotive
Communications and Telecom	www.ti.com/communications
Computers and Peripherals	www.ti.com/computers
Consumer Electronics	www.ti.com/consumer-apps
Energy and Lighting	www.ti.com/energy
Industrial	www.ti.com/industrial
Medical	www.ti.com/medical
Security	www.ti.com/security
Space, Avionics and Defense	www.ti.com/space-avionics-defense
Video and Imaging	www.ti.com/video

TI E2E Community

e2e.ti.com