

# UCD3138064

## Highly Integrated Digital Controller for Isolated Power with 64 kB Program Flash Memory

### Data Manual



PRODUCTION DATA information is current as of publication date. Products conform to specifications per the terms of the Texas Instruments standard warranty. Production processing does not necessarily include testing of all parameters.

Literature Number: SLUSB72A  
MARCH 2013–Revised March 2013

## Contents

<b>1</b>	<b>Introduction</b> .....	<b>6</b>
1.1	Features .....	6
<b>2</b>	<b>Overview</b> .....	<b>7</b>
2.1	Description .....	7
2.2	Ordering Information .....	8
2.3	Product Selection Matrix .....	9
2.4	Functional Block Diagram .....	10
2.5	UCD3138064 64 QFN – Pin Assignments .....	11
2.5.1	64 Pin Device Pin Functions .....	11
2.6	UCD3138064 48 QFN – Pin Assignments .....	13
2.6.1	48 Pin Device Pin Functions .....	13
<b>3</b>	<b>Electrical Specifications</b> .....	<b>15</b>
3.1	ABSOLUTE MAXIMUM RATINGS .....	15
3.2	THERMAL INFORMATION .....	15
3.3	RECOMMENDED OPERATING CONDITIONS .....	15
3.4	ELECTRICAL CHARACTERISTICS .....	16
3.5	PMBus/SMBus/I <sup>2</sup> C Timing .....	19
3.6	Power On Reset (POR) / Brown Out Reset (BOR) .....	20
3.7	Typical Clock Gating Power Savings .....	21
3.8	Typical Temperature Characteristics (Data is taken from the UCD3138) .....	22
<b>4</b>	<b>Functional Overview</b> .....	<b>23</b>
4.1	ARM Processor .....	23
4.2	Memory .....	23
4.2.1	CPU Memory Map and Interrupts .....	23
4.2.1.1	Memory Map (After Reset Operation) .....	24
4.2.1.2	Memory Map (Normal Operation) .....	24
4.2.1.3	Memory Map (System and Peripherals Blocks) .....	24
4.2.2	Boot ROM .....	25
4.2.3	Customer Boot Program .....	26
4.2.4	Flash Management .....	26
4.3	System Module .....	26
4.3.1	Address Decoder (DEC) .....	26
4.3.2	Memory Management Controller (MMC) .....	26
4.3.3	System Management (SYS) .....	26
4.3.4	Central Interrupt Module (CIM) .....	27
4.4	Peripherals .....	28
4.4.1	Digital Power Peripherals .....	28
4.4.1.1	Front End .....	28
4.4.1.2	DPWM Module .....	29
4.4.1.3	DPWM Events .....	30
4.4.1.4	High Resolution DPWM .....	32
4.4.1.5	Over Sampling .....	32
4.4.1.6	DPWM Interrupt Generation .....	32
4.4.1.7	DPWM Interrupt Scaling/Range .....	32
4.5	DPWM Modes of Operation .....	33
4.5.1	Normal Mode .....	33
4.6	Phase Shifting .....	35
4.7	DPWM Multiple Output Mode .....	36
4.8	DPWM Resonant Mode .....	38
4.9	Triangular Mode .....	40
4.10	Leading Edge Mode .....	41

4.11	Synchronous Rectifier MOSFET Ramp and IDE Calculation .....	<a href="#">43</a>
4.12	Automatic Mode Switching .....	<a href="#">43</a>
4.12.1	Phase Shifted Full Bridge Example .....	<a href="#">43</a>
4.12.2	LLC Example .....	<a href="#">44</a>
4.12.3	Mechanism for Automatic Mode Switching .....	<a href="#">46</a>
4.13	DPWMC, Edge Generation, IntraMux .....	<a href="#">47</a>
4.14	Filter .....	<a href="#">48</a>
4.14.1	Loop Multiplexer .....	<a href="#">50</a>
4.14.2	Fault Multiplexer .....	<a href="#">51</a>
4.15	Communication Ports .....	<a href="#">53</a>
4.15.1	SCI (UART) Serial Communication Interface .....	<a href="#">53</a>
4.15.2	PMBUS .....	<a href="#">53</a>
4.15.3	I <sup>2</sup> C .....	<a href="#">54</a>
4.15.4	SPI .....	<a href="#">54</a>
4.16	Timers .....	<a href="#">55</a>
4.16.1	24-bit PWM Timer .....	<a href="#">55</a>
4.16.2	16-Bit PWM Timers .....	<a href="#">56</a>
4.16.3	Watchdog Timer .....	<a href="#">56</a>
4.17	General Purpose ADC12 .....	<a href="#">56</a>
4.18	Miscellaneous Analog .....	<a href="#">57</a>
4.19	Package ID Information .....	<a href="#">57</a>
4.20	Brownout .....	<a href="#">57</a>
4.21	Global I/O .....	<a href="#">58</a>
4.22	Temperature Sensor Control .....	<a href="#">59</a>
4.23	I/O Mux Control .....	<a href="#">59</a>
4.24	Current Sharing Control .....	<a href="#">60</a>
4.25	Temperature Reference .....	<a href="#">60</a>
<b>5</b>	<b>IC Grounding and Layout Recommendations .....</b>	<b><a href="#">61</a></b>
<b>6</b>	<b>Tools and Documentation .....</b>	<b><a href="#">62</a></b>
<b>7</b>	<b>References .....</b>	<b><a href="#">64</a></b>

## List of Figures

3-1	I <sup>2</sup> C/SMBus/PMBus Timing Diagram .....	<a href="#">20</a>
3-2	Bus Timing in Extended Mode.....	<a href="#">20</a>
3-3	Power On Reset (POR) / Brown Out Reset (BOR) .....	<a href="#">20</a>
3-4	EADC LSB Size with 4X Gain (mV) vs. Temperature .....	<a href="#">22</a>
3-5	ADC12 Measurement Temperature Sensor Voltage vs. Temperature.....	<a href="#">22</a>
3-6	ADC12 2.5-V Reference vs. Temperature .....	<a href="#">22</a>
3-7	ADC12 Temperature Sensor Measurement Error vs. Temperature .....	<a href="#">22</a>
3-8	Oscillator Frequency (2MHz Reference, Divided Down from 250MHz) vs. Temperature .....	<a href="#">22</a>
4-1	Check Sum Evaluation Flowchart.....	<a href="#">26</a>
4-2	Input Stage of EADC Module .....	<a href="#">29</a>
4-3	Front End Module .....	<a href="#">29</a>
4-4	Secondary-Referenced Phase-Shifted Full Bridge Control With Synchronous Rectification .....	<a href="#">44</a>
4-5	Secondary-Referenced Half-Bridge Resonant LLC Control With Synchronous Rectification .....	<a href="#">45</a>
4-6	Fault Mux Block Diagram .....	<a href="#">53</a>
4-7	PMBus Address Detection Method .....	<a href="#">54</a>
4-8	SPI Timing Diagram.....	<a href="#">55</a>
4-9	ADC12 Control Block Diagram .....	<a href="#">57</a>
4-10	Internal Temp Sensor.....	<a href="#">59</a>
4-11	Simplified Current Sharing Circuitry .....	<a href="#">60</a>

## List of Tables

2-1	Summary of Key Differences Between UCD3138064 & UCD31318.....	<a href="#">8</a>
2-2	Pin Functions .....	<a href="#">11</a>
2-3	Pin Functions .....	<a href="#">13</a>
3-1	I <sup>2</sup> C/SMBus/PMBus Timing Characteristics.....	<a href="#">19</a>
4-1	Interrupt Priority Table .....	<a href="#">27</a>
4-2	DPWM Interrupt Divide Ratio .....	<a href="#">32</a>

# Highly Integrated Digital Controller for Isolated Power with 64 kB Program Flash Memory

Check for Samples: [UCD3138064](#)

## 1 Introduction

### 1.1 Features

- **64 kB Program Flash Derivative of UCD3138 Family**
  - 2-32 kB Program Flash Memory Banks
  - Supports Execution From 1 Bank, While Programming Another
  - Capability to Update Firmware Without Shutting Down the Power Supply
  - Additional Communication Ports Compared to the UCD3138 (+1 SPI, +1 I2C)
  - RGC Package Pin-to-Pin Compatible with UCD3138 ([SLUSAP2B](#)).
- **Digital Control of up to 3 Independent Feedback Loops**
  - Dedicated PID Based Hardware
  - 2-pole/2-zero Configurable, Non-Linear Control
- **Up to 16MHz Error A/D Converter (EADC)**
  - Configurable Resolution (min: 1mV/LSB)
  - Up to 8x Oversampling and Adaptive Trigger Positioning
  - Hardware Based Averaging (up to 8x)
  - 14 bit Effective DAC
- **Up to 8 High Resolution Digital Pulse Width Modulated (DPWM) Outputs**
  - 250 ps Pulse Width Resolution
  - 4 ns Frequency and Phase Resolution
  - Adjustable Phase Shift and Dead-bands
  - Cycle-by-Cycle Duty Cycle Matching
  - Up to 2 MHz Switching Frequency
- **Configurable Trailing/Leading/Triangular Modulation**
- **Configurable Feedback Control**
  - Voltage, Average Current and Peak Current Mode Control
  - Constant Current, Constant Power
- **Configurable FM, Phase Shift Modulation and PWM**
- **Fast, Automatic and Smooth Mode Switching**
  - Frequency Modulation and PWM
  - Phase Shift Modulation and PWM
- **High Efficiency and Light Load Management**
  - Burst Mode & Ideal Diode Emulation
  - Synchronous Rectifier Soft On/Off
  - Low IC Standby Power
- **Primary Side Voltage Sensing**
- **Flux and Phase Current Balancing for Non-Peak Current Mode Control Applications**
- **Current Share (Average & Master/Slave)**
- **Feature Rich Fault Protection Options**
  - 7 Analog / 4 Digital Comparators,
  - Cycle-by-Cycle Current Limiting
  - Programmable Blanking Time and Fault Counting
  - External Fault Inputs
- **Synchronization of DPWM Waveforms Between Multiple UCD3138064 Devices**
- **14 channel, 12 bit, 267 ksp/s General Purpose ADC with Integrated**
  - Programmable Averaging Filters
  - Dual Sample and Hold
- **Internal Temperature Sensor**
- **Fully Programmable High-Performance 31.25MHz, 32-bit ARM7TDMI-S Processor**
  - 64 kB Program Flash (2-32 kB Banks)
  - 2 kB Data Flash with ECC
  - 4 kB Data RAM
  - 8 kB Boot ROM Enables Firmware Boot-Load
- **Communication Peripherals**
  - 1 - I<sup>2</sup>C/PMBus, 1 - I<sup>2</sup>C (master mode only)
  - 2 - UARTs
  - 1 - SPI
- **Timer Capture with Selectable Input Pins**
- **Built In Watchdog: BOD and POR**
- **64-pin QFN and 48-pin QFN Packages**
- **Operating Temperature: –40°C to 125°C**
- **Fusion Digital Power Designer GUI Support**
- **APPLICATIONS**
  - Power Supplies and Telecom Rectifiers
  - Power Factor Correction
  - Isolated dc-dc Modules



Please be aware that an important notice concerning availability, standard warranty, and use in critical applications of Texas Instruments semiconductor products and disclaimers thereto appears at the end of this data sheet.

## 2 Overview

### 2.1 Description

The UCD3138064 is a digital power supply controller from Texas Instruments offering superior levels of integration and performance in a single chip solution. The UCD3138064, in comparison to Texas Instruments UCD3138 digital power controller ( [Table 2-1](#)), offers 64 kB of program Flash memory (vs 32 kB in UCD3138) and additional options for communication such as SPI and a second I<sup>2</sup>C port. The availability of 64 kB of program Flash memory in 2-32 kB banks, enables the designers to implement dual images of firmware (e.g. one main image + one back-up image) in the device and the flexibility to execute from either of the banks using appropriate algorithms. It also creates the unique opportunity for the processor to load a new program and subsequently execute that program without interrupting power delivery. This feature allows the end user to add new features to the power supply in the field while eliminating any down-time required to load the new program.

The flexible nature of the UCD3138064 makes it suitable for a wide variety of power conversion applications. In addition, multiple peripherals inside the device have been specifically optimized to enhance the performance of AC/DC and isolated DC/DC applications and reduce the solution component count in the IT and network infrastructure space. The UCD3138064 is a fully programmable solution offering customers complete control of their application, along with ample ability to differentiate their solution. At the same time, TI is committed to simplifying our customer's development effort through offering best in class development tools, including application firmware, Code Composer Studio™ software development environment, and TI's Fusion Power Development GUI which enables customers to configure and monitor key system parameters.

At the core of the UCD3138064 controller are the Digital Power Peripherals (DPP). Each DPP implements a high speed digital control loop consisting of a dedicated Error Analog to Digital Converter (EADC), a PID based 2 pole - 2 zero digital compensator and DPWM outputs with 250ps pulse width resolution. The device also contains a 12-bit, 267 ksp/s general purpose ADC with up to 14 channels, timers, interrupt control, PMBus, I<sup>2</sup>C, SPI and UART communications ports. The device is based on a 32-bit ARM7TDMI-S RISC microcontroller that performs real-time monitoring, configures peripherals and manages communications. The ARM microcontroller executes its program out of programmable flash memory as well as on chip RAM and ROM.

In addition to the DPP, specific power management peripherals have been added to enable high efficiency across the entire operating range, high integration for increased power density, reliability, and lowest overall system cost and high flexibility with support for the widest number of control schemes and topologies. Such peripherals include: light load burst mode, synchronous rectification, LLC and phase shifted full bridge mode switching, input voltage feed forward, copper trace current sense, ideal diode emulation, constant current constant power control, synchronous rectification soft on and off, peak current mode control, flux balancing, secondary side input voltage sensing, high resolution current sharing, hardware configurable soft start with pre bias, as well as several other features. Topology support has been optimized for voltage mode and peak current mode controlled phase shifted full bridge, single and dual phase PFC, bridgeless PFC, hard switched full bridge and half bridge, and LLC half bridge and full bridge.

**Table 2-1. Summary of Key Differences Between UCD3138064 & UCD31318**

	UCD3138	UCD3138064
<b>PRODUCT FEATURES</b>		
Program Flash Memory	32 kB	64kB
# of Memory Banks	1 (32 kB)	2 (32 kB each)
SPI Communication Hardware	Not Available	Available (Pins # 35, 36, 38, 39)
I <sup>2</sup> C Communication Hardware (in addition to PMBUS)	Not Available	Available (Pins # 35, 36)
Peak Current Mode Control	EADC2 Only	Available on all EADC channels
EADC A0 Min Output Voltage (Max)	100 mV	21 mV
<b>PIN ASSIGNMENTS</b>		
	UCD3138RGC	UCD3138064RGC
Pin #35	FAULT0	FAULT0/SPI_CS/I2C_DATA
Pin #36	FAULT1	FAULT1/SPI_CLK/I2C_CLK
Pin #38	TDO/SCI_TX0/PMBUS_ALERT/FAULT0	TDO/SCI_TX0/PMBUS_ALERT/FAULT0/SPI_MOSI
Pin#39	TDI/SCI_RX0/PMBUS_CTRL/FAULT1	TDI/SCI_RX0/PMBUS_CTRL/FAULT1/SPI_MISO

## 2.2 Ordering Information

PART NUMBER	PIN COUNT	PACKAGE	SUPPLY	TOP SIDE MARKING	OPERATING TEMPERATURE RANGE, T <sub>A</sub>
UCD3138064RGCT	64	QFN	250 (Small Reel)	UCD3138064	–40°C to 125°C
UCD3138064RGCR	64	QFN	2000 (Large Reel)	UCD3138064	–40°C to 125°C
UCD3138064RGZT	48	QFN	250 (Small Reel)	UCD3138064	–40°C to 125°C
UCD3138064RGZR	48	QFN	2500 (large Reel)	UCD3138064	–40°C to 125°C



### 2.3 Product Selection Matrix

FEATURE	UCD3138064 64 PIN	UCD3138064 48 PIN
ARM7TDMI-S Core Processor	31.25 MHz	31.25 MHz
High Resolution DPWM Outputs (250ps Resolution)	8	8
Number of High Speed Independent Feedback Loops (# Regulated Output Voltages)	3	3
12-bit, 267ksps, General Purpose ADC Channels	14	9
Digital Comparators at ADC Outputs	4	4
Flash Memory (Program)	64 kB	64 KB
Flash Memory (Data)	2 kB	2 KB
Flash Security	√	√
RAM	4 kB	4 KB
DPWM Switching Frequency	up to 2 MHz	up to 2 MHz
Programmable Fault Inputs	2 + 2 <sup>(1)</sup>	1 + 2 <sup>(1)</sup>
High Speed Analog Comparators with Cycle-by-Cycle Current Limiting	7 <sup>(2)</sup>	6 <sup>(2)</sup>
UART (SCI)	2	2
PMBus	1	1
I <sup>2</sup> C	1 <sup>(1)</sup>	1 <sup>(1)</sup>
SPI	1 <sup>(1)</sup>	1 <sup>(1)</sup>
Timers	4 (16 bit) and 1 (24 bit)	4 (16 bit) and 1 (24 bit)
Timer PWM Outputs	2	1 <sup>(1)</sup>
Timer Capture Inputs	1	1 <sup>(1)</sup>
Watchdog	√	√
On Chip Oscillator	√	√
Power-On Reset and Brown-Out Reset	√	√
Sync IN and Sync OUT Functions	√	√
Total GPIO (includes all pins with multiplexed functions such as, DPWM, Fault Inputs, SCI, etc.)	30	24
External Interrupts	1	0
Package Offering	64 Pin QFN (9 mm x 9 mm)	48 Pin QFN (7 mm x 7 mm)

(1) This number represents an alternate pin out that is programmable via firmware. See the UCD3138064 Digital Power Peripherals Programmer's Manual for details.

(2) To facilitate simple OVP and UVP connections both comparators B and C are connected to the AD03 pin.

## 2.4 Functional Block Diagram

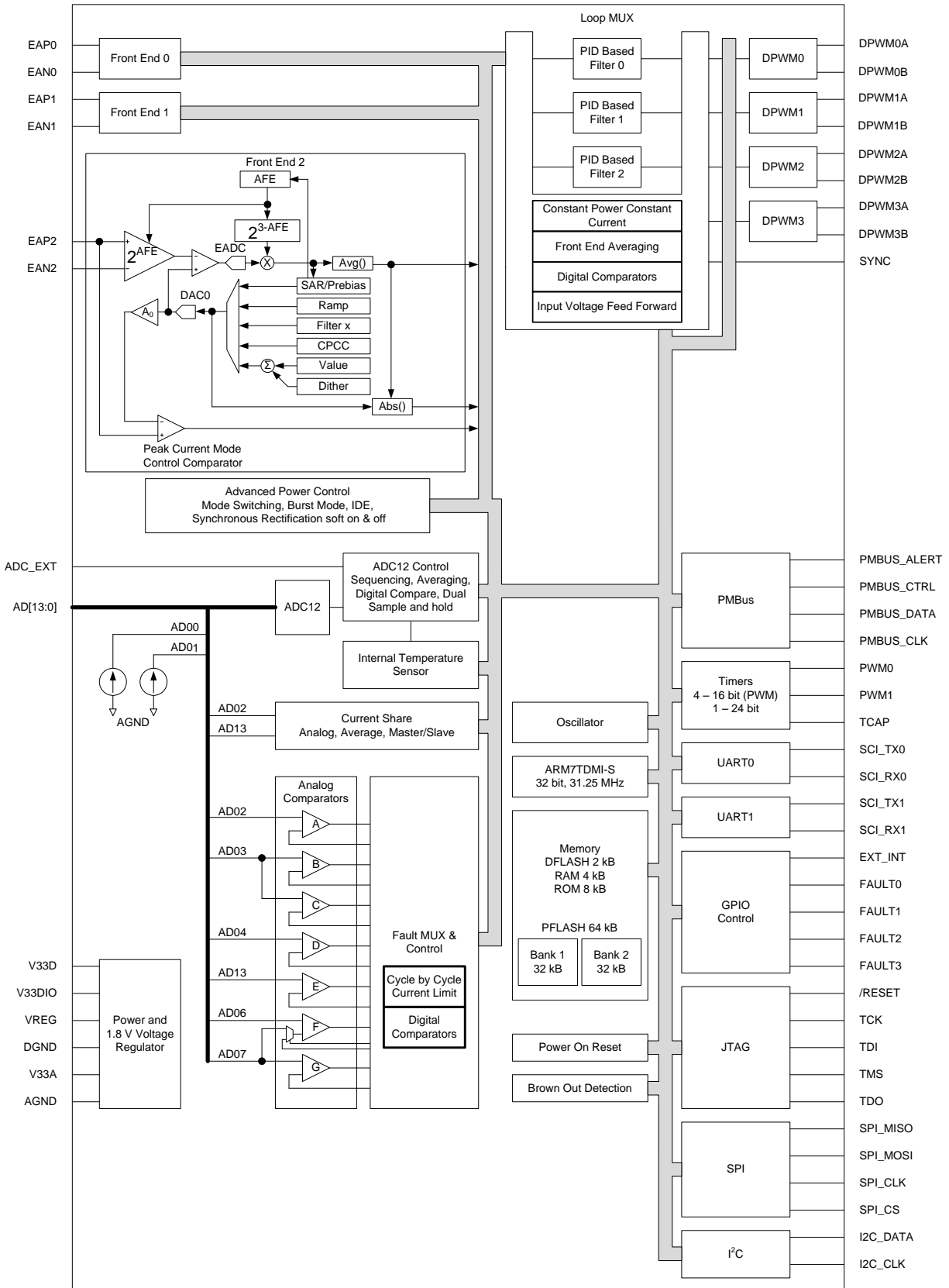

## 2.5 UCD3138064 64 QFN – Pin Assignments

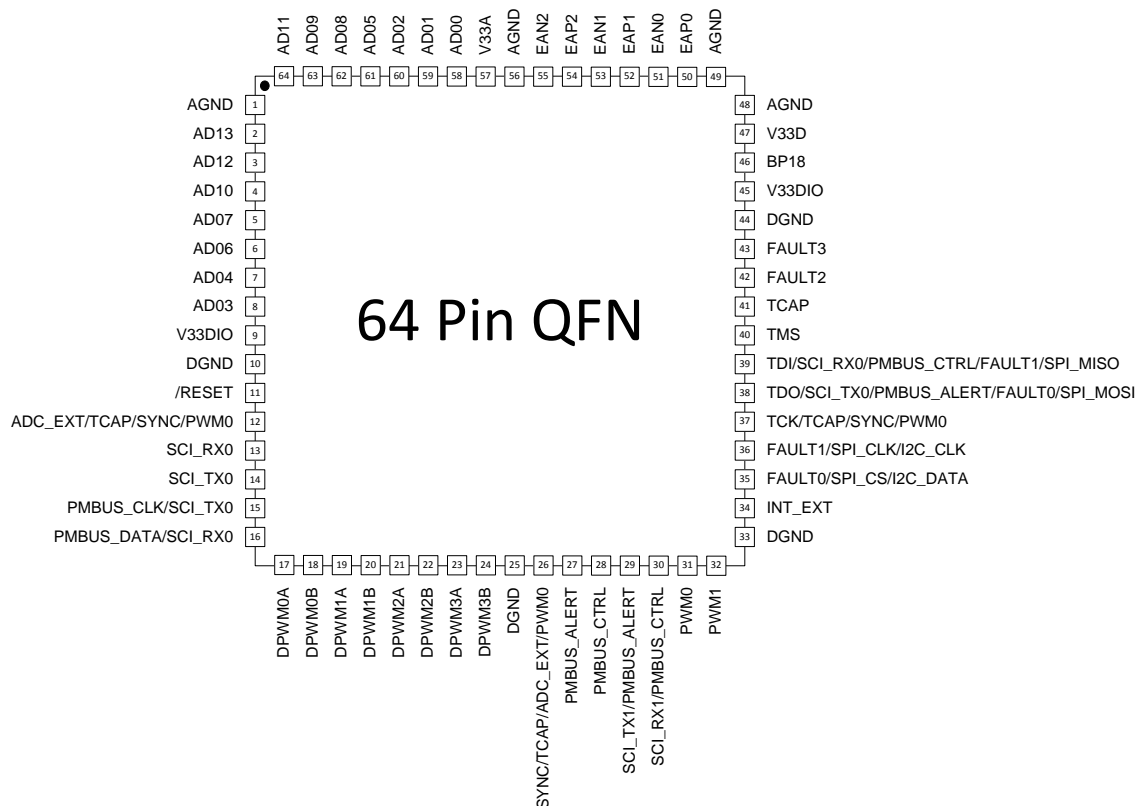

### 2.5.1 64 Pin Device Pin Functions

Additional pin functionality is specified in the following table.

Table 2-2. Pin Functions

PIN	NAME	PRIMARY ASSIGNMENT	ALTERNATE ASSIGNMENT				CONFIGURABLE AS A GPIO?
			NO. 1	NO. 2	NO. 3	NO. 4	
1	AGND	Analog ground					
2	AD13	12-bit ADC, Ch 13, comparator E, I-share	DAC output				
3	AD12	12-bit ADC, Ch 12					
4	AD10	12-bit ADC, Ch 10					
5	AD07	12-bit ADC, Ch 7, Connected to comparator F and reference to comparator G	DAC output				
6	AD06	12-bit ADC, Ch 6, Connected to comparator F	DAC output				
7	AD04	12-bit ADC, Ch 4, Connected to comparator D	DAC output				
8	AD03	12-bit ADC, Ch 3, Connected to comparator B and C					
9	V33DIO	Digital I/O 3.3V core supply					
10	DGND	Digital ground					
11	RESET	Device Reset Input, active low					
12	ADC_EXT	ADC conversion external trigger input	TCAP	SYNC	PWM0		Yes
13	SCI_RX0	SCI RX 0					Yes
14	SCI_TX0	SCI TX 0					Yes
15	PMBUS_CLK	PMBUS Clock (Open Drain)	SCI TX 0				Yes
16	PMBUS_DATA	PMBus data (Open Drain)	SCI RX 0				Yes
17	DPWM0A	DPWM 0A output					Yes
18	DPWM0B	DPWM 0B output					Yes
19	DPWM1A	DPWM 1A output					Yes
20	DPWM1B	DPWM 1B output					Yes

**Table 2-2. Pin Functions (continued)**

PIN	NAME	PRIMARY ASSIGNMENT	ALTERNATE ASSIGNMENT				CONFIGURABLE AS A GPIO?
			NO. 1	NO. 2	NO. 3	NO. 4	
21	DPWM2A	DPWM 2A output					Yes
22	DPWM2B	DPWM 2B output					Yes
23	DPWM3A	DPWM 3A output					Yes
24	DPWM3B	DPWM 3B output					Yes
25	DGND	Digital ground					
26	SYNC	DPWM Synchronize pin	TCAP	ADC_EXT_TRIG	PWM0		Yes
27	PMBUS_ALERT	PMBus Alert (Open Drain)					Yes
28	PMBUS_CTRL	PMBus Control (Open Drain)					Yes
29	SCI_TX1	SCI TX 1	PMBUS_ALERT				Yes
30	SCI_RX1	SCI RX 1	PMBUS_CTRL				Yes
31	PWM0	General purpose PWM 0					Yes
32	PWM1	General purpose PWM 1					Yes
33	DGND	Digital ground					
34	INT_EXT	External Interrupt					Yes
35	FAULT0	External fault input 0	SPI_CS	I2C_DATA			Yes
36	FAULT1	External fault input 1	SPI_CLK	I2C_CLK			Yes
37	TCK <sup>(1)</sup>	JTAG TCK (for manufacturer test only)	TCAP	SYNC	PWM0		Yes
38	TDO <sup>(1)</sup>	JTAG TDO (for manufacturer test only)	SCI_TX0	PMBUS_ALERT	FAULT0	SPI_MOSI	Yes
39	TDI <sup>(1)</sup>	JTAG TDI (for manufacturer test only)	SCI_RX0	PMBUS_CTRL	FAULT1	SPI_MISO	Yes
40	TMS <sup>(1)</sup>	JTAG TMS (for manufacturer test only)					Yes
41	TCAP	Timer capture input					Yes
42	FAULT2	External fault input 2					Yes
43	FAULT3	External fault input 3					Yes
44	DGND	Digital ground					
45	V33DIO	Digital I/O 3.3V core supply					
46	BP18	1.8V Bypass					
47	V33D	Digital 3.3V core supply					
48	AGND	Substrate analog ground					
49	AGND	Analog ground					
50	EAP0	Channel #0, differential analog voltage, positive input					
51	EAN0	Channel #0, differential analog voltage, negative input					
52	EAP1	Channel #1, differential analog voltage, positive input					
53	EAN1	Channel #1, differential analog voltage, negative input					
54	EAP2	Channel #2, differential analog voltage, positive input					
55	EAN2	Channel #2, differential analog voltage, negative input					
56	AGND	Analog ground					
57	V33A	Analog 3.3V supply					
58	AD00	12-bit ADC, Ch 0, Connected to current source					
59	AD01	12-bit ADC, Ch 1, Connected to current source					
60	AD02	12-bit ADC, Ch 2, Connected to comparator A, I-share					
61	AD05	12-bit ADC, Ch 5					
62	AD08	12-bit ADC, Ch 8					
63	AD09	12-bit ADC, Ch 9					
64	AD11	12-bit ADC, Ch 11					

(1) Fusion Digital Power based debug tools are recommended instead of JTAG.

## 2.6 UCD3138064 48 QFN – Pin Assignments

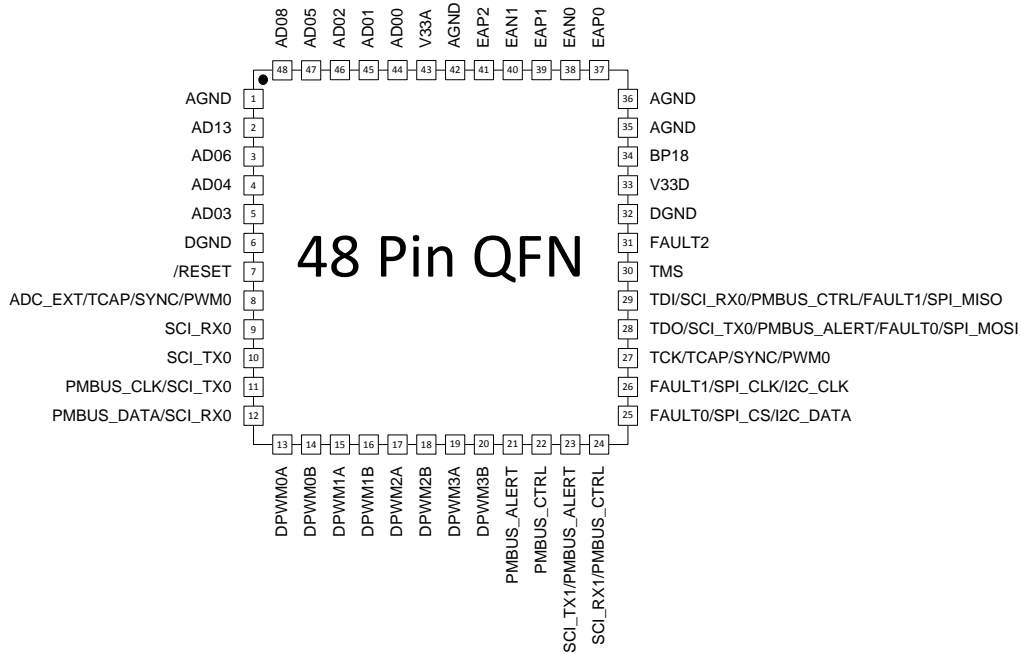

### 2.6.1 48 Pin Device Pin Functions

Additional pin functionality is specified in the following table.

Table 2-3. Pin Functions

PIN	NAME	PRIMARY ASSIGNMENT	ALTERNATE ASSIGNMENT				CONFIGURABLE AS A GPIO?
			NO. 1	NO. 2	NO. 3	NO. 4	
1	AGND	Analog ground					
2	AD13	12-bit ADC, Ch 13, Connected to comparator E, I-share	DAC Output				
3	AD06	12-bit ADC, Ch 6, Connected to comparator F	DAC Output				
4	AD04	12-bit ADC, Ch 4, Connected to comparator D	DAC Output				
5	AD03	12-bit ADC, Ch 3, Connected to comparator B & C					
6	DGND	Digital ground					
7	RESET	Device Reset Input, active low					
8	ADC_EXT	ADC conversion external trigger input	TCAP	SYNC	PWM0		Yes
9	SCL_RX0	SCL_RX0					Yes
10	SCL_TX0	SCL_TX0					Yes
11	PMBUS_CLK	PMBus Clock (Open Drain)	SCL_TX0				Yes
12	PMBUS_DATA	PMBus data (Open Drain)	SCL_RX0				Yes
13	DPWM0A	DPWM 0A output					Yes
14	DPWM0B	DPWM 0B output					Yes
15	DPWM1A	DPWM 1A output					Yes
16	DPWM1B	DPWM 1B output					Yes
17	DPWM2A	DPWM 2A output					Yes
18	DPWM2B	DPWM 2B output					Yes
19	DPWM3A	DPWM 3A output					Yes
20	DPWM3B	DPWM 3B output					Yes
21	PMBUS_ALERT	PMBus Alert (Open Drain)					Yes
22	PMBUS_CTRL	PMBus Control (Open Drain)					Yes
23	SCL_TX1	SCL TX 1	PMBUS_ALERT				Yes
24	SCL_RX1	SCL RX 1	PMBUS_CTRL				Yes
25	FAULT0	External fault input 0	SPL_CS	I2C_DATA			Yes

**Table 2-3. Pin Functions (continued)**

PIN	NAME	PRIMARY ASSIGNMENT	ALTERNATE ASSIGNMENT				CONFIGURABLE AS A GPIO?
			NO. 1	NO. 2	NO. 3	NO. 4	
26	FAULT1	External fault input 1	SPI_CLK	I2C_CLK			Yes
27	TCK <sup>(1)</sup>	JTAG TCK (for manufacturer test only)	TCAP	SYNC	PWM0		Yes
28	TDO <sup>(1)</sup>	JTAG TDO (for manufacturer test only)	SCI_TX0	PMBUS_ALERT	FAULT0	SPI_MOSI	Yes
29	TDI <sup>(1)</sup>	JTAG TDI (for manufacturer test only)	SCI_RX0	PMBUS_CTRL	FAULT1	SPI_MISO	Yes
30	TMS <sup>(1)</sup>	JTAG TMS (for manufacturer test only)					Yes
31	FAULT2	External fault input 2					Yes
32	DGND	Digital ground					
33	V33D	Digital 3.3V core supply					
34	BP18	1.8V Bypass					
35	AGND	Analog ground					
36	AGND	Analog ground					
37	EAP0	Channel #0, differential analog voltage, positive input					
38	EAN0	Channel #0, differential analog voltage, negative input					
39	EAP1	Channel #1, differential analog voltage, positive input					
40	EAN1	Channel #1, differential analog voltage, negative input					
41	EAP2	Channel #2, differential analog voltage, positive input					
42	AGND	Analog ground					
43	V33A	Analog 3.3V supply					
44	AD00	12-bit ADC, Ch 0, Connected to current source					
45	AD01	12-bit ADC, Ch 1, Connected to current source					
46	AD02	12-bit ADC, Ch 2, Connected to comparator A, I-share					
47	AD05	12-bit ADC, Ch 5					
48	AD08	AD08 12-bit ADC, Ch 8					

(1) Fusion Digital Power based debug tools are recommended instead of JTAG.

### 3 Electrical Specifications

#### 3.1 ABSOLUTE MAXIMUM RATINGS <sup>(1)</sup>

over operating free-air temperature range (unless otherwise noted)

		VALUE		UNIT
		MIN	MAX	
V33D	V33D to DGND	-0.3	3.8	V
V33DIO	V33DIO to DGND	-0.3	3.8	V
V33A	V33A to AGND	-0.3	3.8	V
BP18	BP18 to DGND	-0.3	2.5	V
DGND – AGND	Ground difference		0.3	V
All Pins, excluding AGND <sup>(2)</sup>	Voltage applied to any pin	-0.3	3.8	V
T <sub>OPT</sub>	Junction Temperature	-40	125	°C
T <sub>STG</sub>	Storage temperature	-55	150	°C

(1) Stresses beyond those listed under absolute maximum ratings may cause permanent damage to the device. These are stress ratings only, and functional operation of the device at these or any other conditions beyond those indicated under recommended operating conditions is not implied. Exposure to absolute-maximum-rated conditions for extended periods may affect device reliability.

(2) Referenced to DGND

#### 3.2 THERMAL INFORMATION

THERMAL METRIC <sup>(1)</sup>		UCD3138064	UCD3138064	UNITS
		64-PIN QFN	48-PIN QFN	
$\theta_{JA}$	Junction-to-ambient thermal resistance <sup>(2)</sup>	19.9	26.9	°C/W
$\theta_{JCTop}$	Junction-to-case (top) thermal resistance <sup>(3)</sup>	5.7	12.5	
$\theta_{JB}$	Junction-to-board thermal resistance <sup>(4)</sup>	3.1	3.9	
$\Psi_{JT}$	Junction-to-top characterization parameter <sup>(5)</sup>	0.1	0.2	
$\Psi_{JB}$	Junction-to-board characterization parameter <sup>(6)</sup>	3.0	4.0	
$\theta_{JCbott}$	Junction-to-case (bottom) thermal resistance <sup>(7)</sup>	0.3	0.5	

(1) For more information about traditional and new thermal metrics, see the *IC Package Thermal Metrics* application report, [SPRA953](#)

(2) The junction-to-ambient thermal resistance under natural convection is obtained in a simulation on a JEDEC-standard, high-K board, as specified in JESD51-7, in an environment described in JESD51-2a.

(3) The junction-to-case (top) thermal resistance is obtained by simulating a cold plate test on the package top. No specific JEDEC-standard test exists, but a close description can be found in the ANSI SEMI standard G30-88.

(4) The junction-to-board thermal resistance is obtained by simulating in an environment with a ring cold plate fixture to control the PCB temperature, as described in JESD51-8.

(5) The junction-to-top characterization parameter,  $\Psi_{JT}$ , estimates the junction temperature of a device in a real system and is extracted from the simulation data for obtaining  $\theta_{JA}$ , using a procedure described in JESD51-2a (sections 6 and 7).

(6) The junction-to-board characterization parameter,  $\Psi_{JB}$ , estimates the junction temperature of a device in a real system and is extracted from the simulation data for obtaining  $\theta_{JA}$ , using a procedure described in JESD51-2a (sections 6 and 7).

(7) The junction-to-case (bottom) thermal resistance is obtained by simulating a cold plate test on the exposed (power) pad. No specific JEDEC standard test exists, but a close description can be found in the ANSI SEMI standard G30-88.

#### 3.3 RECOMMENDED OPERATING CONDITIONS

over operating free-air temperature range (unless otherwise noted)

		MIN	TYP	MAX	UNIT
V33D	Digital power	3.0	3.3	3.6	V
V33DIO	Digital I/O power	3.0	3.3	3.6	V
V33A	Analog power	3.0	3.3	3.6	V
BP18	1.8 V digital power	1.6	1.8	2.0	V
T <sub>J</sub>	Junction temperature	-40	-	125	°C

### 3.4 ELECTRICAL CHARACTERISTICS

V33A = V33D = V33DIO = 3.3V; 1 $\mu$ F from BP18 to DGND, T<sub>J</sub> = –40°C to 125°C (unless otherwise noted)

PARAMETER		TEST CONDITION	MIN	TYP	MAX	UNIT
<b>SUPPLY CURRENT</b>						
I33A		Measured on V33A. The device is powered up but all ADC12 and EADC sampling is disabled		6.3		mA
I33DIO		All GPIO and communication pins are open		0.35		mA
I33D		ROM program execution		60		mA
I33D		Flash programming in ROM mode			70	mA
I33		The device is in ROM mode with all DPWMs enabled and switching at 2 MHz. The DPWMs are all unloaded.			100	mA
<b>ERROR ADC INPUTS EAP, EAN</b>						
EAP – AGND			–0.15		1.998	V
EAP – EAN			–0.256		1.848	V
Typical error range		AFE = 0	–256		248	mV
EAP – EAN Error voltage digital resolution		AFE = 3	0.8	1	1.20	mV
		AFE = 2	1.7	2	2.30	mV
		AFE = 1	3.55	4	4.45	mV
		AFE = 0	6.90	8	9.10	mV
R <sub>EA</sub>	Input impedance (See <a href="#">Figure 4-2</a> )	AGND reference	0.5			M $\Omega$
I <sub>OFFSET</sub>	Input offset current (See <a href="#">Figure 4-2</a> )		–5		5	$\mu$ A
EADC Offset		Input voltage = 0 V at AFE = 0	–2		2	LSB
		Input voltage = 0 V at AFE = 1	–2.5		2.5	LSB
		Input voltage = 0 V at AFE = 2	–3		–3	LSB
		Input voltage = 0 V at AFE = 3	–4		4	LSB
Sample Rate					15.62 5	MHz
Analog Front End Amplifier Bandwidth				100		MHz
A <sub>0</sub>	Gain	See <a href="#">Figure 4-3</a>		1		V/V
	Minimum output voltage				21	mV
<b>EADC DAC</b>						
DAC range			0		1.6	V
VREF DAC reference resolution		10 bit, No dithering enabled		1.56		mV
VREF DAC reference resolution		With 4 bit dithering enabled		97.6		$\mu$ V
INL			–2.0		2.0	LSB
DNL		Does not include MSB transition	–1.0		2.1	LSB
DNL at MSB transition				–1.4		LSB
DAC reference voltage			1.58		1.61	V
T	Settling Time	From 10% to 90%		250		ns
<b>ADC12</b>						
I <sub>BIAS</sub>	Bias current for PMBus address pins		9.5		10.5	$\mu$ A
Measurement range for voltage monitoring			0		2.5	V
Internal ADC reference voltage		–40°C to 125°C	2.475	2.500	2.53	V
Change in Internal ADC reference from 25°C reference voltage		–40°C to 25°C		–0.7		mV
		25°C to 125°C		–2.1		



**ELECTRICAL CHARACTERISTICS (continued)**

V33A = V33D = V33DIO = 3.3V; 1 $\mu$ F from BP18 to DGND, T<sub>J</sub> = –40°C to 125°C (unless otherwise noted)

PARAMETER		TEST CONDITION	MIN	TYP	MAX	UNIT
ADC12 INL integral nonlinearity		ADC_SAMPLING_SEL = 6 for all ADC12 data, 25 °C to 125 °C	–7.5/+2.9			LSB
ADC12 DNL differential nonlinearity			–0.7/+3.2			LSB
ADC Zero Scale Error			–7		7	mV
ADC Full Scale Error			–35		35	mV
Input bias		2.5 V applied to pin			200	nA
Input leakage resistance		ADC_SAMPLING_SEL= 6 or 0		1		M $\Omega$
Input Capacitance				10		pF
ADC single sample conversion time		ADC_SAMPLING_SEL= 6 or 0		3.9		$\mu$ s
<b>DIGITAL INPUTS/OUTPUTS (1)(2)</b>						
V <sub>OL</sub>	Low-level output voltage (3)	I <sub>OH</sub> = 4 mA, V33DIO = 3 V			DGND + 0.25	V
V <sub>OH</sub>	High-level output voltage (3)	I <sub>OH</sub> = –4 mA, V33DIO = 3 V	V33DIO – 0.6			V
V <sub>IH</sub>	High-level input voltage	V33DIO = 3 V	2.1			V
V <sub>IL</sub>	Low-level input voltage	V33DIO = 3 V			1.1	V
I <sub>OH</sub>	Output sinking current				4	mA
I <sub>OL</sub>	Output sourcing current		–4			mA
<b>SYSTEM PERFORMANCE</b>						
TWD	Watchdog time out resolution	Total time is: TWD x (WDCTRL.PERIOD+1)	14.6	17	20.5	ms
	Time to disable DPWM output based on active FAULT pin signal	High level on FAULT pin		70		ns
	Processor master clock (MCLK)			31.25		MHz
t <sub>Delay</sub>	Digital filter delay (4)	(1 clock = 32ns)			6	MCLKs
	Retention period of flash content (data retention and program)	T <sub>J</sub> = 25°C	100			years
	Program time to erase one page or block in data flash or program flash			20		ms
	Program time to write one word in data flash or program flash			30		$\mu$ s
f <sub>(PCLK)</sub>	Internal oscillator frequency		240	250	260	MHz
	Sync-in/sync-out pulse width	Sync pin		256		ns
	Flash Read			1		MCLKs
	Flash Write			20		$\mu$ s
I <sub>SHARE</sub>	Current share current source (See Figure 4-11)		238		259	$\mu$ A
R <sub>SHARE</sub>	Current share resistor (See Figure 4-11)		9.75		10.3	k $\Omega$
<b>POWER ON RESET AND BROWN OUT (V33D pin, See Figure 3-3)</b>						
V <sub>GH</sub>		Voltage good High		2.7		V
V <sub>GL</sub>		Voltage good Low		2.5		V
V <sub>res</sub>	Voltage at which IReset signal is valid (5)			0.8		V
T <sub>POR</sub>		Time delay after Power is good or RESET* relinquished		1		ms

(1) DPWM outputs are low after reset. Other GPIO pins are configured as inputs after reset.

(2) On the 40 pin package V33DIO is connected to V33D internally.

(3) The maximum total current, I<sub>OHmax</sub> and I<sub>OLmax</sub> for all outputs combined, should not exceed 12 mA to hold the maximum voltage drop specified. Maximum sink current per pin = –6 mA at V<sub>OL</sub>; maximum source current per pin = 6 mA at V<sub>OH</sub>.

(4) Time from close of error ADC sample window to time when digitally calculated control effort (duty cycle) is available. This delay, which has no variation associated with it, must be accounted for when calculating the system dynamic response.

(5) Characterized by design and not production tested.

**ELECTRICAL CHARACTERISTICS (continued)**V33A = V33D = V33DIO = 3.3V; 1 $\mu$ F from BP18 to DGND, T<sub>J</sub> = –40°C to 125°C (unless otherwise noted)

PARAMETER		TEST CONDITION	MIN	TYP	MAX	UNIT
Brownout		Internal signal warning of brownout conditions		2.9		V
T <sub>EXC1</sub>	The time it takes from the device to exit a reset state and begin executing program flash bank 1 (32 kB). <sup>(5)</sup>	I <sub>RESET</sub> goes from a low state to a high state. This is approximately equivalent to toggling the external reset pin from low to high state.		9.5		ms
T <sub>EXC2</sub>	The time it takes from the device to exit a reset state and begin executing program flash bank 2 (32 kB). <sup>(5)</sup>	I <sub>RESET</sub> goes from a low state to a high state. This is approximately equivalent to toggling the external reset pin from low to high state.		19		ms
T <sub>EXCT</sub>	The time it takes from the device to exit a reset state and begin executing the total program flash (64 kB). <sup>(5)</sup>	I <sub>RESET</sub> goes from a low state to a high state. This is approximately equivalent to toggling the external reset pin from low to high state.		19		ms
<b>TEMPERATURE SENSOR<sup>(5)</sup></b>						
V <sub>TEMP</sub>		Voltage range of sensor	1.46		2.44	V
	Voltage resolution	Volts/°C		5.9		mV/°C
	Temperature resolution	Degree C per bit		0.1034		°C/LSB
	Accuracy <sup>(5)(6)</sup>	-40°C to 125°C	-10	±5	10	°C
	Temperature range	-40°C to 125°C	-40		125	°C
I <sub>TEMP</sub>		Current draw of sensor when active		30		μA
T <sub>ON</sub>		Turn on time / settling time of sensor		100		μs
V <sub>AMB</sub>	Ambient temperature	Trimmed 25°C reading		1.85		V
<b>ANALOG COMPARATOR</b>						
DAC	Reference DAC Range		0		2.5	V
	Reference Voltage		2.478	2.5	2.513	V
	Bits			7		bits
	INL <sup>(7)</sup>		-0.42		0.21	LSB
	DNL <sup>(7)</sup>		0.06		0.12	LSB
	Offset		-5.5		19.5	mV
	Time to disable DPWM output based on 0 V to 2.5 V step input on the analog comparator.				150	ns
	Reference DAC buffered output load <sup>(8)</sup>		0.5		1	mA
	Buffer offset (-0.5 mA)		4.6		8.3	mV
	Buffer offset (1.0 mA)		-0.05		17	mV

(6) Ambient temperature offset value should be used from the TEMPSENCTRL register to meet accuracy.

(7) Characterized by design and not production tested.

(8) Available from reference DACs for comparators D, E, F and G.

### 3.5 PMBus/SMBus/I<sup>2</sup>C Timing

The timing characteristics and timing diagram for the communications interface that supports I<sup>2</sup>C, SMBus, and PMBus in Slave or Master mode are shown in Table 3-1, Figure 3-1, and Figure 3-2. The numbers in Table 3-1 are for 400 kHz operating frequency. However, the device supports all three speeds, standard (100 kHz), fast (400 kHz), and fast mode plus (1 MHz).

Table 3-1. I<sup>2</sup>C/SMBus/PMBus Timing Characteristics

PARAMETER	TEST CONDITIONS	MIN	TYP	MAX	UNIT
Typical values at T <sub>A</sub> = 25°C and VCC = 3.3 V (unless otherwise noted)					
f <sub>SMB</sub>	SMBus/PMBus operating frequency	Slave mode, SMBC 50% duty cycle	100	1000	kHz
f <sub>I2C</sub>	I <sup>2</sup> C operating frequency	Slave mode, SCL 50% duty cycle	100	1000	kHz
t <sub>(BUF)</sub>	Bus free time between start and stop <sup>(1)</sup>		1.3		µs
t <sub>(HD:STA)</sub>	Hold time after (repeated) start <sup>(1)</sup>		0.6		µs
t <sub>(SU:STA)</sub>	Repeated start setup time <sup>(1)</sup>		0.6		µs
t <sub>(SU:STO)</sub>	Stop setup time <sup>(1)</sup>		0.6		µs
t <sub>(HD:DAT)</sub>	Data hold time	Receive mode	0		ns
t <sub>(SU:DAT)</sub>	Data setup time		100		ns
t <sub>(TIMEOUT)</sub>	Error signal/detect <sup>(2)</sup>			35	ms
t <sub>(LOW)</sub>	Clock low period		1.3		µs
t <sub>(HIGH)</sub>	Clock high period <sup>(3)</sup>		0.6	50	µs
t <sub>(LOW:SEXT)</sub>	Cumulative clock low slave extend time <sup>(4)</sup>			25	ms
t <sub>f</sub>	Clock/data fall time	Rise time t <sub>r</sub> = (V <sub>ILmax</sub> - 0.15) to (V <sub>IHmin</sub> + 0.15)	20 + 0.1 Cb <sup>(5)</sup>	300	ns
t <sub>r</sub>	Clock/data rise time	Fall time t <sub>f</sub> = 0.9 VDD to (V <sub>ILmax</sub> - 0.15)	20 + 0.1 Cb <sup>(5)</sup>	300	ns
C <sub>b</sub>	Total capacitance of one bus line			400	pF

- (1) Fast mode, 400 kHz
- (2) The device times out when any clock low exceeds t<sub>(TIMEOUT)</sub>.
- (3) t<sub>(HIGH)</sub>, Max, is the minimum bus idle time. SMBC = SMBD = 1 for t > 50 ms causes reset of any transaction that is in progress. This specification is valid when the NC\_SMB control bit remains in the default cleared state (CLK[0] = 0).
- (4) t<sub>(LOW:SEXT)</sub> is the cumulative time a slave device is allowed to extend the clock cycles in one message from initial start to the stop.
- (5) C<sub>b</sub> (pF)

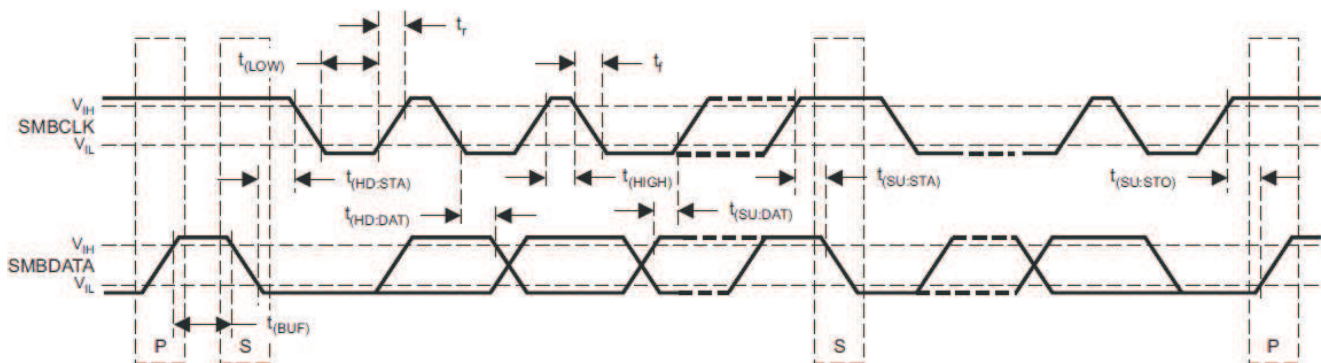
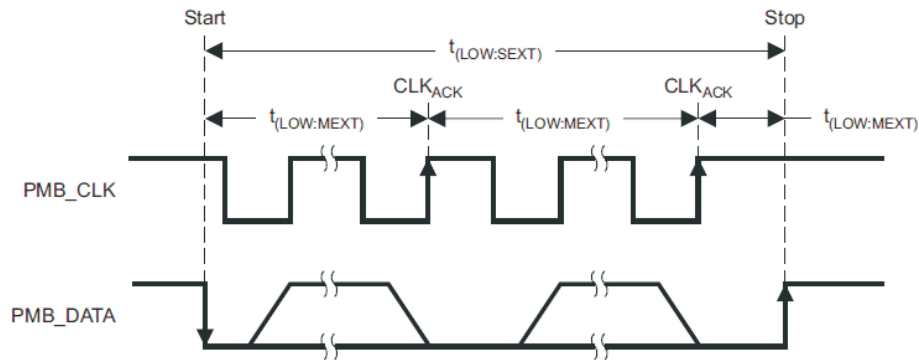
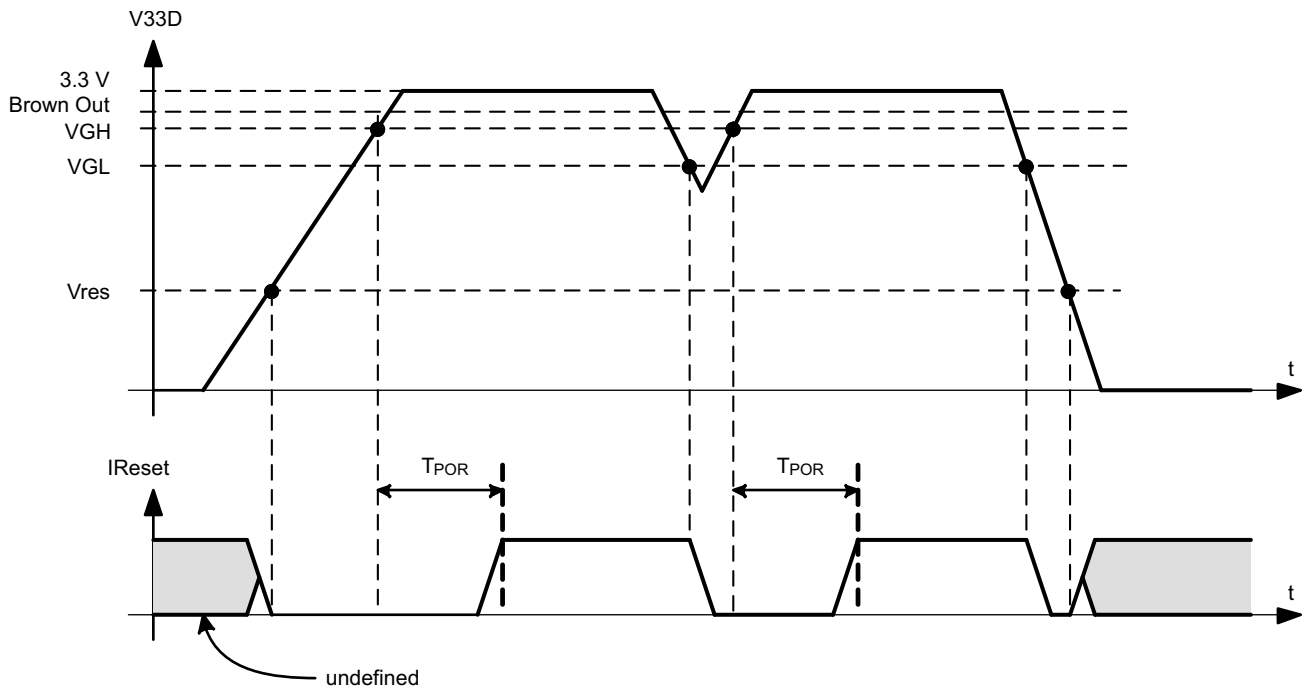

Figure 3-1. I<sup>2</sup>C/SMBus/PMBus Timing Diagram



**Figure 3-2. Bus Timing in Extended Mode**

### 3.6 Power On Reset (POR) / Brown Out Reset (BOR)



**Figure 3-3. Power On Reset (POR) / Brown Out Reset (BOR)**

- V<sub>GH</sub>** – This is the V<sub>33D</sub> threshold where the internal power is declared good. The UCD3138064 comes out of reset when above this threshold.
- V<sub>GL</sub>** – This is the V<sub>33D</sub> threshold where the internal power is declared bad. The device goes into reset when below this threshold.
- V<sub>res</sub>** – This is the V<sub>33D</sub> threshold where the internal reset signal is no longer valid. Below this threshold the device is in an indeterminate state.
- I<sub>Reset</sub>** – This is the internal reset signal. When low, the device is held in reset. This is equivalent to holding the reset pin on the IC low.
- T<sub>POR</sub>** – The time delay from when V<sub>GH</sub> is exceeded to when the device comes out of reset.
- Brown Out** – This is the V<sub>33D</sub> voltage threshold at which the device sets the brown out status bit. In addition an interrupt can be triggered if enabled.

### 3.7 Typical Clock Gating Power Savings

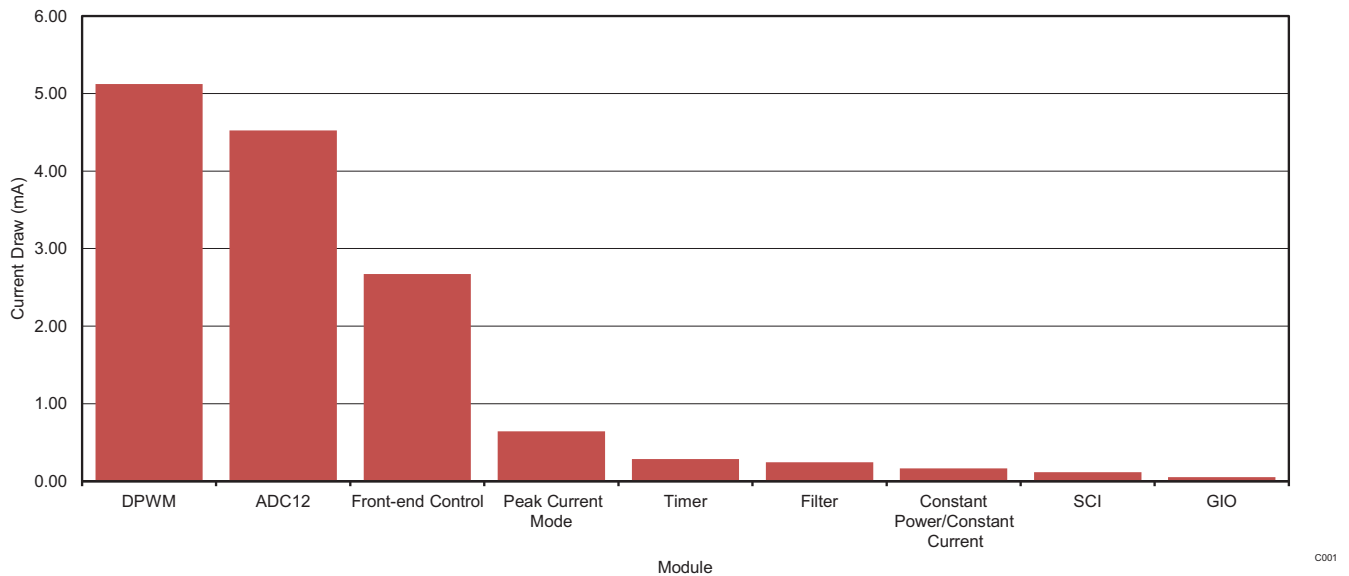

The power disable control register provides control bits that can enable or disable the clock to several peripherals such as, PCM, CPCC, digital filters, front ends, DPWMs, UARTs, ADC-12 and more.

By default, all these controls are enabled. If a specific peripheral is not used the clock gate can be disabled in order to block the propagation of the clock signal to that peripheral and therefore reduce the overall current consumption of the device. The power savings chart displays the power savings per module. For example there are 4 DPWM modules, therefore, if all 4 are disabled a total of ~20 mA can be saved.

### 3.8 Typical Temperature Characteristics (Data is taken from the UCD3138)

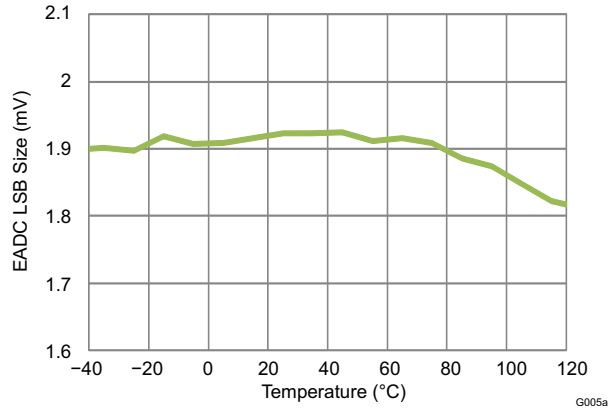

**Figure 3-4. EADC LSB Size with 4X Gain (mV) vs. Temperature**

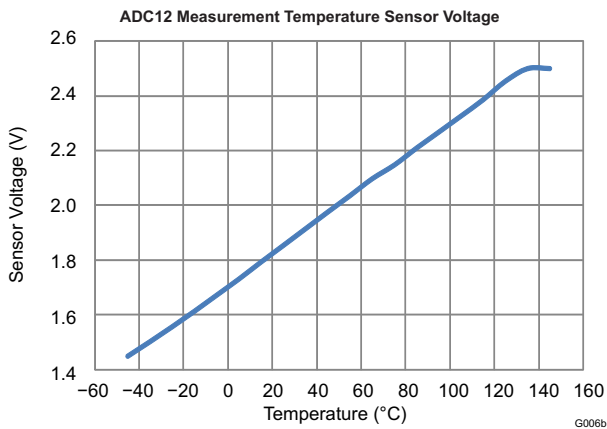

**Figure 3-5. ADC12 Measurement Temperature Sensor Voltage vs. Temperature**

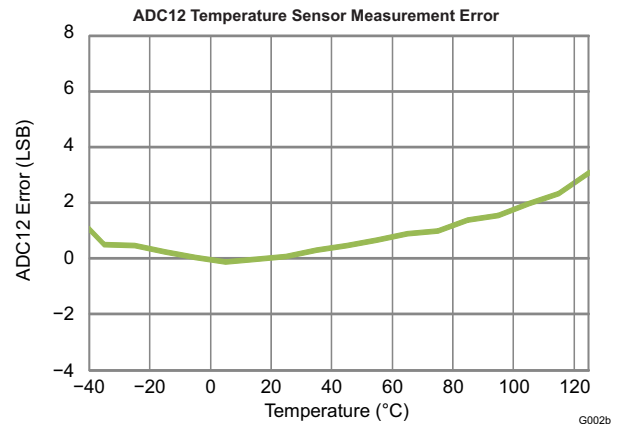

**Figure 3-7. ADC12 Temperature Sensor Measurement Error vs. Temperature**

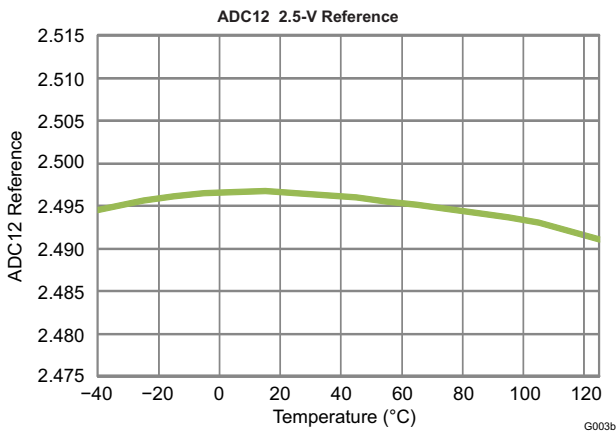

**Figure 3-6. ADC12 2.5-V Reference vs. Temperature**

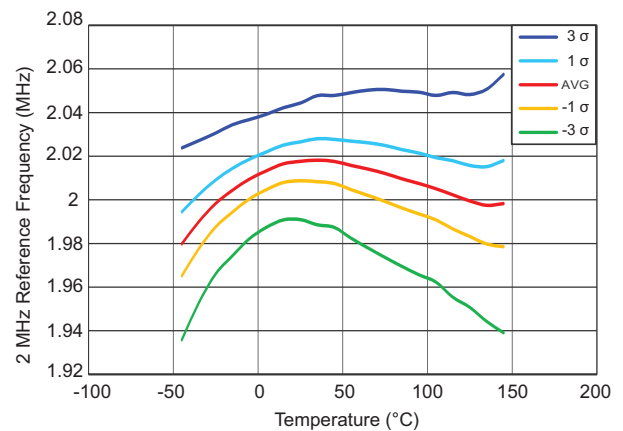

**Figure 3-8. Oscillator Frequency (2MHz Reference, Divided Down from 250MHz) vs. Temperature**

## 4 Functional Overview

### 4.1 ARM Processor

The ARM7TDMI-S processor is a synthesizable member of the ARM family of general purpose 32-bit microprocessors. The ARM architecture is based on RISC (Reduced Instruction Set Computer) principles where two instruction sets are available. The 32-bit ARM instruction set and the 16-bit Thumb instruction set. The Thumb instructions allow for higher code density equivalent to a 16-bit microprocessor, with the performance of the 32-bit microprocessor.

The three-staged pipelined ARM processor has fetch, decode and execute stage architecture. Major blocks in the ARM processor include a 32-bit ALU, 32 x 8 multiplier, and a barrel shifter.

### 4.2 Memory

The UCD3138064 (ARM7TDMI-S) is a Von-Neumann architecture, where a single bus provides access to all of the memory modules. All of the memory module addresses are sequentially aligned along the same address range. This applies to program flash, data flash, ROM and all other peripherals.

Within the UCD3138064 architecture, there is a 2048x32-bit Boot ROM that contains the initial firmware startup routines for PMBUS communication and non-volatile (FLASH) memory download. This boot ROM is executed after power-up-reset checks if there is a valid FLASH program written. If a valid program is present, the ROM code branches to the main FLASH-program execution. If there is no valid program, the device waits for a program download through the PMBus.

UCD3138064 also supports customization of the boot program by allowing an alternative boot routine to be executed from program FLASH. This feature enables assignment of a unique address to each device; therefore, enabling firmware reprogramming even when several devices are connected on the same communication bus.

There are three separate flash memory areas present inside the device. There are 2-32 kB program flash blocks and 1-2 kB data flash area. The 32 kB program areas are organized as 8 k x 32 bit memory blocks and are intended to be for the firmware programs. The blocks are configured with page erase capability for erasing blocks as small as 1 kB per page, or with a mass erase for erasing the entire 32 kB array. The flash endurance is specified at 1000 erase/write cycles and the data retention is good for 100 years. The 2 kB data flash array is organized as a 512 x 32 bit memory (32 byte page size). The data flash is intended for firmware data value storage and data logging. Thus, the Data flash is specified as a high endurance memory of 20 k cycles with embedded error correction code (ECC).

For run time data storage and scratchpad memory, a 4 kB RAM is available. The RAM is organized as a 1 k x 32 bit array.

The availability of 64 kB of program Flash memory in 2-32 kB banks, enables the designers to implement dual images of firmware (e.g. one main image + one back-up image) in the device and the flexibility to execute from either of the banks using appropriate algorithms. It also creates the unique opportunity for the processor to load a new program and subsequently execute that program without interrupting power delivery. This feature allows the end user to add new features to the power supply while eliminating any down-time required to load the new program.

#### 4.2.1 CPU Memory Map and Interrupts

When the device comes out of power-on-reset, the data memories are mapped to the processor as follows:

#### 4.2.1.1 Memory Map (After Reset Operation)

Address	Size (Bytes)	Module
0x0000_0000 – 0x0003_FFFF In 32 repeated blocks of 8 k each	32 X 8 k	Boot ROM
0x0004_0000 – 0x0004_7FFF	32 k	Program Flash 1
0x0004_8000 – 0x0004_FFFF	32 k	Program Flash 2
0x0006_8800 – 0x0006_8FFF	2 k	Data Flash
0x0006_9000 – 0x0006_9FFF	4 k	Data RAM

#### 4.2.1.2 Memory Map (Normal Operation)

Just before the boot ROM program gives control to flash program, the ROM configures the memory as follows:

Address	Size (Bytes)	Module
0x0000_0000 – 0x0000_7FFF	32 k	Program Flash 1 (or 2)
0x0000_8000 – 0x0000_FFFF	32 k	Program Flash 2 (or 1)
0x0002_0000 – 0x0002_1FFF	8 k	Boot ROM
0x0006_8800 – 0x0006_8FFF	2 k	Data Flash
0x0006_9000 – 0x0006_9FFF	4 k	Data RAM

#### 4.2.1.3 Memory Map (System and Peripherals Blocks)

Address	Size	Module
0x0012_0000 - 0x0012_00FF	256	Loop Mux
0x0013_0000 - 0x0013_00FF	256	Fault Mux
0x0014_0000 - 0x0014_00FF	256	ADC
0x0015_0000 - 0x0015_00FF	256	DPWM 3
0x0016_0000 - 0x0016_00FF	256	Filter 2
0x0017_0000 - 0x0017_00FF	256	DPWM 2
0x0018_0000 - 0x0018_00FF	256	Front End/Ramp Interface 2
0x0019_0000 - 0x0019_00FF	256	Filter 1
0x001A_0000 - 0x001A_00FF	256	DPWM 1
0x001B_0000 - 0x001B_00FF	256	Front End/Ramp Interface 1
0x001C_0000 - 0x001C_00FF	256	Filter 0
0x001D_0000 - 0x001D_00FF	256	DPWM 0
0x001E_0000 - 0x001E_00FF	256	Front End/Ramp Interface 0
0xFFFF7_EC00 - 0xFFFF7_ECFF	256	UART 0
0xFFFF7_ED00 - 0xFFFF7_EDFF	256	UART 1
0xFFFF7_F000 - 0xFFFF7_F0FF	256	Miscellaneous Analog Control
0xFFFF7_F600 - 0xFFFF7_F6FF	256	PMBus Interface
0xFFFF7_FA00 - 0xFFFF7_FAFF	256	GIO
0xFFFF7_FD00 - 0xFFFF7_FDFF	256	Timer
0xFFFF_FD00 - 0xFFFF_FDFF	256	MMC
0xFFFF_FE00 - 0xFFFF_FEFF	256	DEC
0xFFFF_FF20 - 0xFFFF_FF37	23	CIM
0xFFFF_FF40 - 0xFFFF_FF50	16	PSA
0xFFFF_FF00 - 0xFFFF_FFEC	28	SYS



The registers and bit definitions inside the System and Peripheral blocks are detailed in the programmer's guide for each peripheral.

#### 4.2.2 Boot ROM

The UCD3138064 incorporates a 8 kB boot ROM. This boot ROM includes support for:

- Program download through the PMBus
- Device initialization
- Examining and modifying registers and memory
- Verifying and executing program flash automatically
- Jumping to a customer defined boot program
- Checksum evaluation to facilitate program execution from either Program Flash 1 or Program Flash 2

The Boot ROM is entered automatically on device reset. It initializes the device and then performs checksums on the program flash. If the first 2 kB of either program FLASH has a valid checksum, the program branches to location 0 in the appropriate Program FLASH module. This permits the use of a custom boot program. If the first checksum fails, it performs some additional checksum calculations to determine where the valid program is located. This permits full automated program memory checking, when there is no need for a custom boot program. The complete decision tree is located in [Figure 4-1](#). "Branch to Program Flash 1" means Flash 1 is at address 0x0000, and Flash 2 is at address 0x8000. "Branch to Program Flash 2" means Flash 2 is at address 0x0000, and Flash 1 is at address 0x8000.

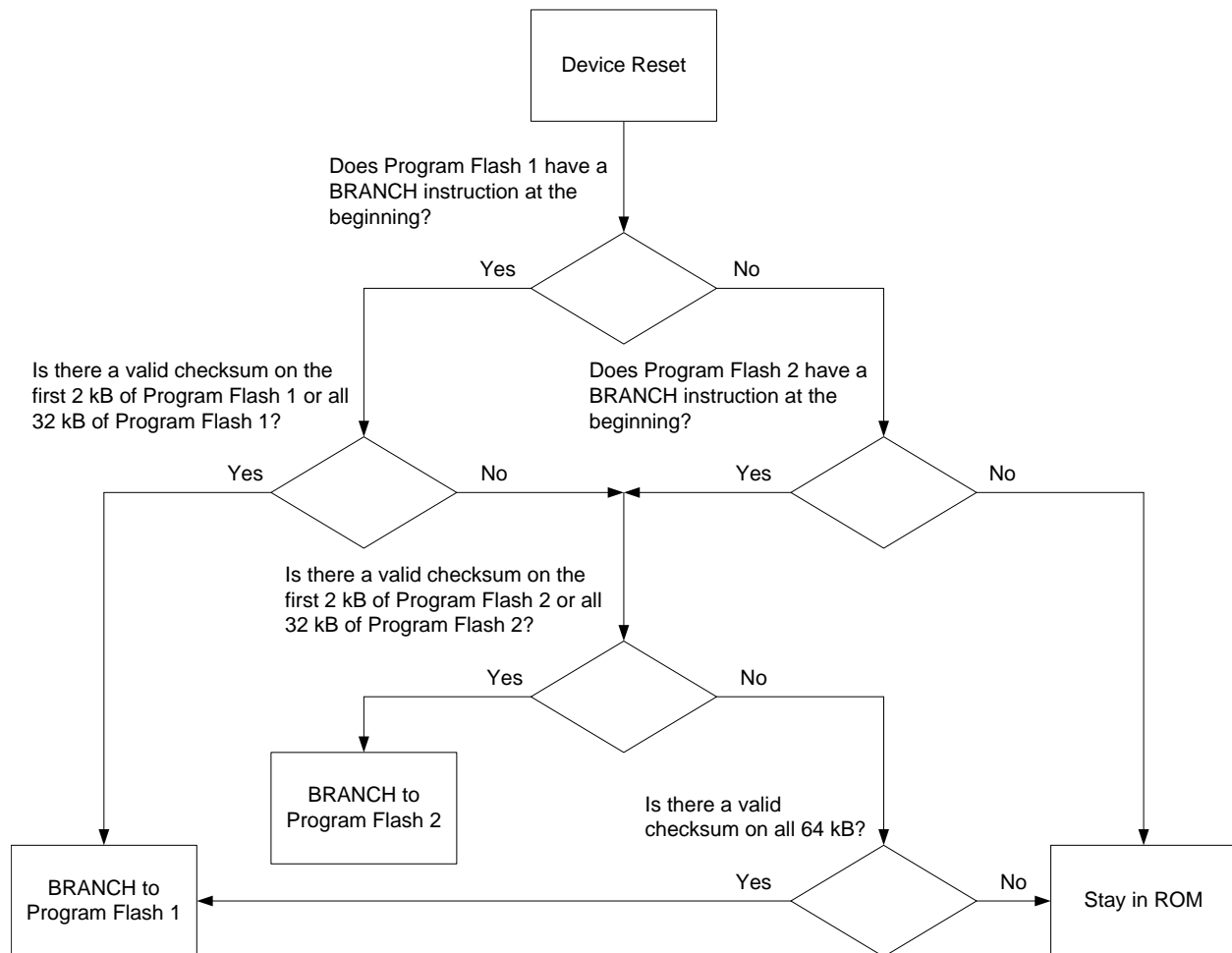

Figure 4-1. Check Sum Evaluation Flowchart

If neither checksum is valid, the Boot ROM stays in control, and accepts commands via the PMBus interface. These functions can be used to read and write to all memory locations in the UCD3138064. Typically they are used to download a program to Program Flash, and to command its execution.

### 4.2.3 Customer Boot Program

As described above, it is possible to generate a user boot program using 2 kB or more of the Program Flash. This can support things which the Boot ROM does not support, including:

- Program download via UART – useful especially for applications where the UCD3138064 is isolated from the host (e.g., PFC)
- Encrypted download – useful for code security in field updates.
- PMBus download at different addresses

### 4.2.4 Flash Management

The UCD3138064 offers a variety of features providing for easy prototyping and easy flash programming. At the same time, high levels of security are possible for production code, even with field updates. Standard firmware will be provided for storing multiple copies of system parameters in data flash. This minimizes the risk of losing information if data-flash programming is interrupted.

## 4.3 System Module

The System Module contains the interface logic and configuration registers to control and configure all the memory, peripherals and interrupt mechanisms. The blocks inside the system module are the address decoder, memory management controller, system management unit, central interrupt unit, and clock control unit.

### 4.3.1 Address Decoder (DEC)

The Address Decoder generates the memory selects for the FLASH, ROM and RAM arrays. The memory map addresses are selectable through configurable register settings. These memory selects can be configured from 1 kB to 16 MB. Power on reset uses the default addresses in the memory map for ROM execution, which is then configured by the ROM code to the application setup. During access to the DEC registers, a wait state is asserted to the CPU. DEC registers are only writable in the ARM privilege mode for user mode protection.

### 4.3.2 Memory Management Controller (MMC)

The MMC manages the interface to the peripherals by controlling the interface bus for extending the read and write accesses to each peripheral. The unit generates eight peripheral select lines with 1 kB of address space decoding.

### 4.3.3 System Management (SYS)

The SYS unit contains the software access protection by configuring user privilege levels to memory or peripherals modules. It contains the ability to generate fault or reset conditions on decoding of illegal address or access conditions. A clock control setup for the processor clock (MCLK) speed, is also available.

### 4.3.4 Central Interrupt Module (CIM)

The CIM accepts 32 interrupt requests for meeting firmware timing requirements. The ARM processor supports two interrupt levels: FIQ and IRQ. FIQ is the highest priority interrupt. The CIM provides hardware expansion of interrupts by use of FIQ/IRQ vector registers for providing the offset index in a vector table. This numerical index value indicates the highest precedence channel with a pending interrupt and is used to locate the interrupt vector address from the interrupt vector table. Interrupt channel 0 has the lowest precedence and interrupt channel 31 has the highest precedence. To remove the interrupt request, the firmware should clear the request as the first action in the interrupt service routine. The request channels are maskable, allowing individual channels to be selectively disabled or enabled.

**Table 4-1. Interrupt Priority Table**

NAME	MODULE COMPONENT OR REGISTER	DESCRIPTION	PRIORITY
BRN_OUT_INT	Brownout	Brownout interrupt	0 (Lowest)
EXT_INT	External Interrupts	Interrupt on external input pin	1
WDRST_INT	Watchdog Control	Interrupt from watchdog exceeded (reset)	2
WDWAKE_INT	Watchdog Control	Wake-up interrupt when watchdog equals half of set watch time	3
SCI_ERR_INT	UART or SCI Control	UART or SCI error Interrupt. Frame, parity or overrun	4
SCI_RX_0_INT	UART or SCI Control	UART0 RX buffer has a byte	5
SCI_TX_0_INT	UART or SCI Control	UART0 TX buffer empty	6
SCI_RX_1_INT	UART or SCI Control	UART1 RX buffer has a byte	7
SCI_TX_1_INT	UART or SCI Control	UART1 TX buffer empty	8
PMBUS_INT		PMBus related interrupt	9
DIG_COMP_SPI_I2C_INT	12-bit ADC Control, SPI, I <sup>2</sup> C	Digital comparator, SPI and I <sup>2</sup> C interrupt	10
FE0_INT	Front End 0	"Prebias complete", "Ramp Delay Complete", "Ramp Complete", "Load Step Detected", "Over-Voltage Detected", "EADC saturated"	11
FE1_INT	Front End 1	"Prebias complete", "Ramp Delay Complete", "Ramp Complete", "Load Step Detected", "Over-Voltage Detected", "EADC saturated"	12
FE2_INT	Front End 2	"Prebias complete", "Ramp Delay Complete", "Ramp Complete", "Load Step Detected", "Over-Voltage Detected", "EADC saturated"	13
PWM3_INT	16-bit Timer PWM 3	16-bit Timer PWM3 counter overflow or compare interrupt	14
PWM2_INT	16-bit Timer PWM 2	16-bit Timer PWM2 counter Overflow or compare interrupt	15
PWM1_INT	16-bit Timer PWM 1	16-bit Timer PWM1 counter overflow or compare interrupt	16
PWM0_INT	16-bit timer PWM 0	16-bit Timer PWM1 counter overflow or compare interrupt	17
OVF24_INT	24-bit Timer Control	24-bit Timer counter overflow interrupt	18
CAPTURE_1_INT	24-bit Timer Control	24-bit Timer capture 1 interrupt	19
Reserved for future use			20
CAPTURE_0_INT	24-bit Timer Control	24-bit Timer capture 0 interrupt	21
COMP_0_INT	24-bit Timer Control	24-bit Timer compare 0 interrupt	22
CPCC_INT	Constant Power Constant Current	Mode switched in CPCC module Flag needs to be read for details	23
ADC_CONV_INT	12-bit ADC Control	ADC end of conversion interrupt	24
FAULT_INT	Fault Mux Interrupt	Analog comparator interrupts, Over-Voltage detection, Under-Voltage detection, LLM load step detection	25
DPWM3	DPWM3	Same as DPWM1	26
DPWM2	DPWM2	Same as DPWM1	27

**Table 4-1. Interrupt Priority Table (continued)**

NAME	MODULE COMPONENT OR REGISTER	DESCRIPTION	PRIORITY
DPWM1	DPWM1	1) Every (1-256) switching cycles 2) Fault Detection 3) Mode switching	28
DPWM0	DPWM0	Same as DPWM1	29
EXT_FAULT_INT	External Faults	Fault pin interrupt	30
SYS_SSI_INT	System Software	System software interrupt	31 (highest)

## 4.4 Peripherals

### 4.4.1 Digital Power Peripherals

At the core of the UCD3138064 controller are 3 Digital Power Peripherals (DPP). Each DPP can be configured to drive from one to eight DPWM outputs. Each DPP consists of:

- Differential input error ADC (EADC) with sophisticated controls
- Hardware accelerated digital 2-pole/2-zero PID based filter
- Digital PWM module with support for a variety of topologies

These can be connected in many different combinations, with multiple filters and DPWMs. They are capable of supporting functions like input voltage feed forward, current mode control, and constant current/constant power, etc.. The simplest configuration is shown in the following figure:



#### 4.4.1.1 Front End

Figure 4-2 shows the block diagram of the front end module. It consists of a differential amplifier, an adjustable gain error amplifier, a high speed flash analog to digital converter (EADC), digital averaging filters and a precision high resolution set point DAC reference. The programmable gain amplifier in concert with the EADC and the adjustable digital gain on the EADC output work together to provide 9 bits of range with 6 bits of resolution on the EADC output. The output of the Front End module is a 9 bit sign extended result with a gain of 1 LSB / mV. Depending on the value of AFE selected, the resolution of this output could be either 1, 2, 4 or 8 LSBs. In addition Front End 0 has the ability to automatically select the AFE value such that the minimum resolution is maintained that still allows the voltage to fit within the range of the measurement. The EADC control logic receives the sample request from the DPWM module for initiating an EADC conversion. EADC control circuitry captures the EADC-9-bit-code and strobes the filter for processing of the representative error. The set point DAC has 10 bits with an additional 4 bits of dithering resulting in an effective resolution of 14 bits. This DAC can be driven from a variety of sources to facilitate things like soft start, nested loops, etc. Some additional features include the ability to change the polarity of the error measurement and an absolute value mode which automatically adds the DAC value to the error.

It is possible to operate the controller in a peak current mode control configuration. In this mode topologies like the phase shifted full bridge converter can be controlled to maintain transformer flux balance. The internal DAC can be ramped at a synchronously controlled slew rate to achieve a programmable slope compensation. This eliminates the sub-harmonic oscillation as well as improves input voltage feed-forward performance. A0 is a unity gain buffer used to isolate the peak current mode comparator. The offset of this buffer is specified in the [Electrical Characteristics](#) table.

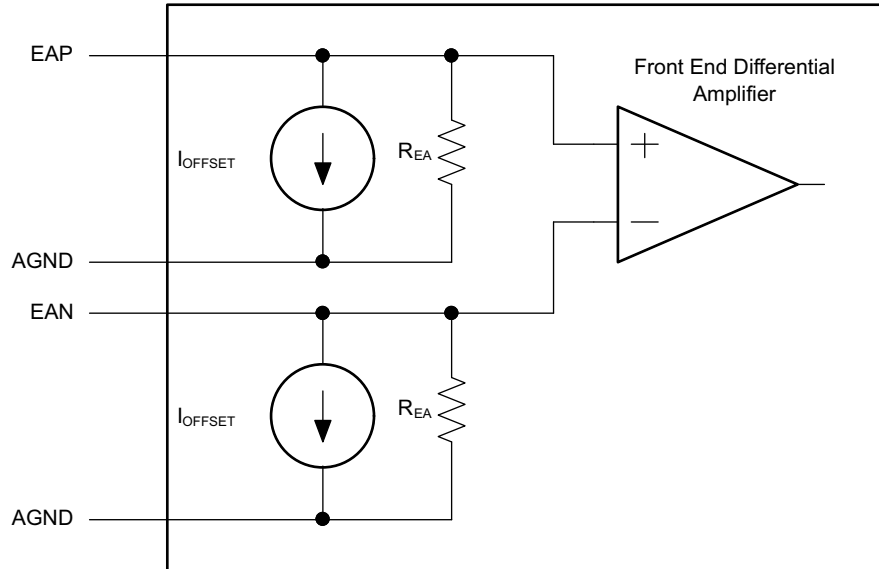

Figure 4-2. Input Stage of EADC Module

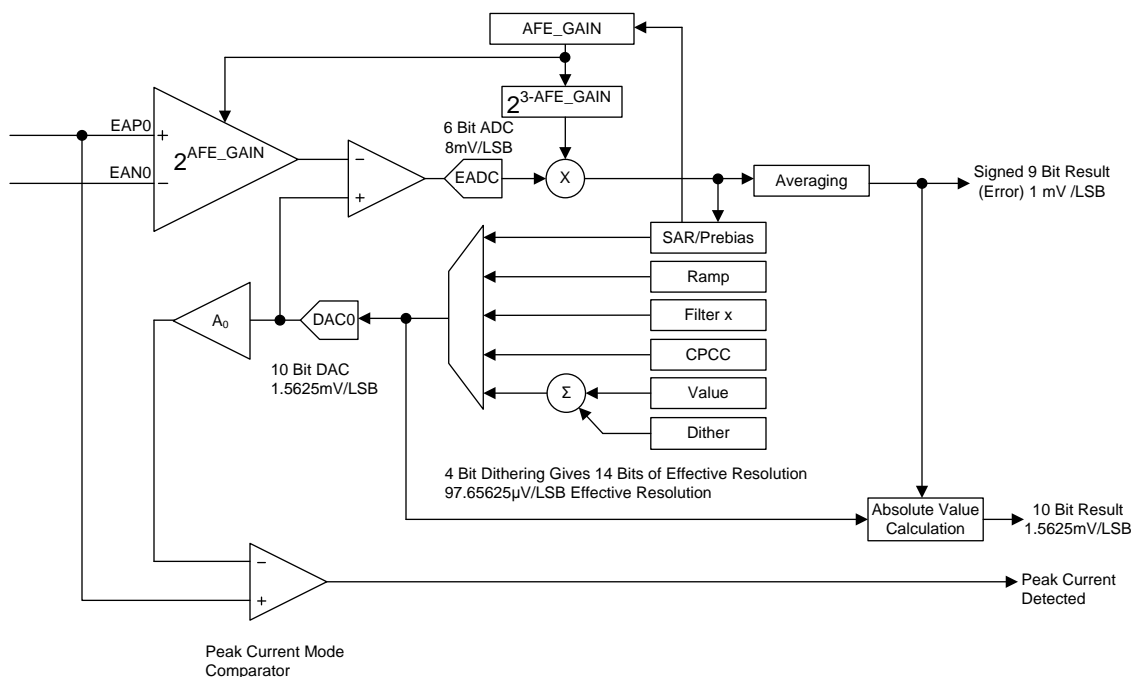

Figure 4-3. Front End Module

#### 4.4.1.2 DPWM Module

The DPWM module represents one complete DPWM channel with 2 independent outputs, A and B. Multiple DPWM modules within the UCD3138064 system can be configured to support all key power topologies. DPWM modules can be used as independent DPWM outputs, each controlling one power supply output voltage rail. It can also be used as a synchronized DPWM—with user selectable phase shift between the DPWM channels to control power supply outputs with multiphase or interleaved DPWM configurations.

The output of the filter feeds the high resolution DPWM module. The DPWM module produces the pulse width modulated outputs for the power stage switches. The filter calculates the necessary duty ratio as a 24-bit number in Q23 fixed point format (23 bit integer with 1 sign bit). This represents a value within the range 0.0 to 1.0. This duty ratio value is used to generate the corresponding DPWM output ON time. The resolution of the DPWM ON time is 250 psec.

Each DPWM module can be synchronized to another module or to an external synchronization signal. An input SYNC signal causes a DPWM ramp timer to reset. The SYNC signal outputs—from each of the four DPWM modules—occur when the ramp timer crosses a programmed threshold. This allows the phase of the DPWM outputs for multiple power stages to be tightly controlled.

The DPWM logic takes the output of the filter and converts it into the correct DPWM output for several power supply topologies. It provides for programmable dead times and cycle adjustments for current balancing between phases. It controls the triggering of the EADC. It can synchronize to other DPWMs or to external sources. It can provide synchronization information to other DPWMs or to external recipients. In addition, it interfaces to several fault handling circuits. Some of the control for these fault handling circuits is in the DPWM registers. Fault handling is covered in the Fault Mux section.

Each DPWM module supports the following features:

- Dedicated 14 bit time-base with period and frequency control
- Shadow period register for end of period updates.
- Quad-event control registers (A and B, rising and falling) (Events 1-4)
  - Used for on/off DPWM duty ratio updates.
- Phase control relative to other DPWM modules
- Sample trigger placement for output voltage sensing at any point during the DPWM cycle.
- Support for 2 independent edge placement DPWM outputs (same frequency or period setting)
- Dead-time between DPWM A and B outputs
- High Resolution PWM capability – 250 ps
- Pulse cycle adjustment of up to  $\pm 8.192 \mu\text{s}$  (  $32768 \times 250 \text{ ps}$  )
- Active high/ active low output polarity selection
- Provides events to trigger both CPU interrupts and start of ADC12 conversions.

#### 4.4.1.3 DPWM Events

Each DPWM can control the following timing events:

1. *Sample Trigger Count*—This register defines where the error voltage is sampled by the EADC in relationship to the DPWM period. The programmed value set in the register should be one fourth of the value calculated based on the DPWM clock. As the DCLK (DCLK = 62.5 MHz max) controlling the circuitry runs at one fourth of the DPWM clock (PCLK = 250MHz max). When this sample trigger count is equal to the DPWM Counter, it initiates a front end calculation by triggering the EADC, resulting in a CLA calculation, and a DPWM update. Over-sampling can be set for 2, 4 or 8 times the sampling rate.
2. *Phase Trigger Count*—count offset for slaving another DPWM (Multi-Phase/Interleaved operation).
3. *Period*—low resolution switching period count. (count of PCLK cycles)
4. *Event 1*—count offset for rising DPWM A event. (PCLK cycles)
5. *Event 2*—DPWM count for falling DPWM A event that sets the duty ratio. Last 4 bits of the register are for high resolution control. Upper 14 bits are the number of PCLK cycle counts.
6. *Event 3*—DPWM count for rising DPWM B event. Last 4 bits of the register are for high resolution control. Upper 14 bits are the number of PCLK cycle counts.
7. *Event 4*—DPWM count for falling DPWM B event. Last 4 bits of the register are for high resolution control. Upper 14 bits are the number of PCLK cycle counts.
8. *Cycle Adjust*—Constant offset for Event 2 and Event 4 adjustments.

Basic comparisons between the programmed registers and the DPWM counter can create the desired edge placements in the DPWM. High resolution edge capability is available on Events 2, 3 and 4.

Multi Mode Open Loop

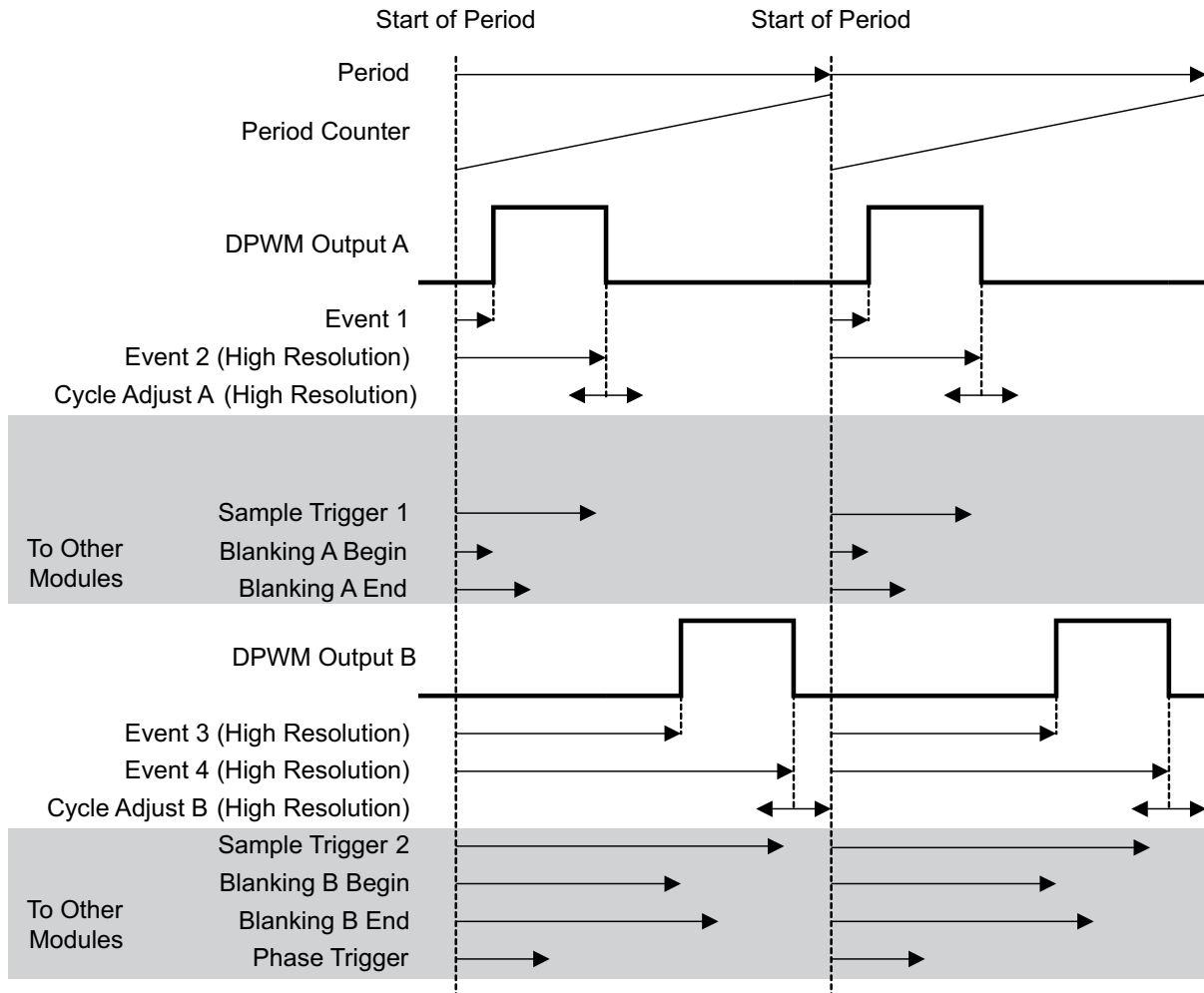

Events which change with DPWM mode:

- DPWM A Rising Edge = Event 1
- DPWM A Falling Edge = Event 2 + Cycle Adjust A
- DPWM B Rising Edge = Event 3
- DPWM B Falling Edge = Event 4 + Cycle Adjust B
- Phase Trigger = Phase Trigger Register value

Events always set by their registers, regardless of mode:

- Sample Trigger 1, Sample Trigger 2, Blanking A Begin, Blanking A End, Blanking B Begin, Blanking B End

The drawing above is for multi-mode, open loop. Open loop means that the DPWM is controlled entirely by its own registers, not by the filter output. In other words, the power supply control loop is not closed.

The Sample Trigger signals are used to trigger the Front End to sample input signals. The Blanking signals are used to blank fault measurements during noisy events, such as FET turn on and turn off. Additional DPWM modes are described below.

#### 4.4.1.4 High Resolution DPWM

Unlike conventional PWM controllers where the frequency of the clock dictates the maximum resolution of PWM edges, the UCD3138064 DPWM can generate waveforms with resolutions as small as 250 ps. This is 16 times the resolution of the clock driving the DPWM module.

This is achieved by providing the DPWM mechanism with 16 phase shifted clock signals of 250 MHz each. The high resolution section of DPWM can be enabled or disabled, also the resolution can be defined in several steps between 4 ns to 250 ps. This is done by setting the values of PWM\_HR\_MULTI\_OUT\_EN , HIRE\_SCALE and ALL\_PHASE\_CLK\_ENA inside the DPWM Control Register 1. See the Power Peripherals programmer's manual for details.

#### 4.4.1.5 Over Sampling

The DPWM module has the capability to trigger an over sampling event by initiating the EADC to sample the error voltage. The default "00" configuration has the DPWM trigger the EADC once based on the sample trigger register value. The over sampling register has the ability to trigger the sampling 2, 4 or 8 times per PWM period. Thus the time the over sample happens is at the divide by 2, 4, or 8 time set in the sampling register. The "01" setting triggers 2X over sampling, the "10" setting triggers 4X over sampling, and the "11" triggers over sampling at 8X.

#### 4.4.1.6 DPWM Interrupt Generation

The DPWM has the capability to generate a CPU interrupt based on the PWM frequency programmed in the period register. The interrupt can be scaled by a divider ratio of up to 255 for developing a slower interrupt service execution loop. This interrupt can be fed to the ADC circuitry for providing an ADC12 trigger for sequence synchronization. [Table 4-2](#) outlines the divide ratios that can be programmed.

#### 4.4.1.7 DPWM Interrupt Scaling/Range

**Table 4-2. DPWM Interrupt Divide Ratio**

Interrupt Divide Setting	Interrupt Divide Count	Interrupt Divide Count (hex)	Switching Period Frames (assume 1MHz loop)	Number of 32 MHz Processor Cycles
1	0	00	1	32
2	1	01	2	64
3	3	03	4	128
4	7	07	8	256
5	15	0F	16	512
6	31	1F	32	1024
7	47	2F	48	1536
8	63	3F	64	2048
9	79	4F	80	2560
10	95	5F	96	3072
11	127	7F	128	4096
12	159	9F	160	5120
13	191	BF	192	6144
14	223	DF	224	7168
15	255	FF	256	8192



## 4.5 DPWM Modes of Operation

The DPWM is a complex logic system which is highly configurable to support several different power supply topologies. The discussion below will focus primarily on waveforms, timing and register settings, rather than on logic design.

The DPWM is centered on a period counter, which counts up from 0 to PRD, and then is reset and starts over again.

The DPWM logic causes transitions in many digital signals when the period counter hits the target value for that signal.

### 4.5.1 Normal Mode

In Normal mode, the Filter output determines the pulse width on DPWM A. DPWM B fits into the rest of the switching period, with a dead time separating it from the DPWM A on-time. It is useful for buck topologies, among others. Here is a drawing of the Normal Mode waveforms:

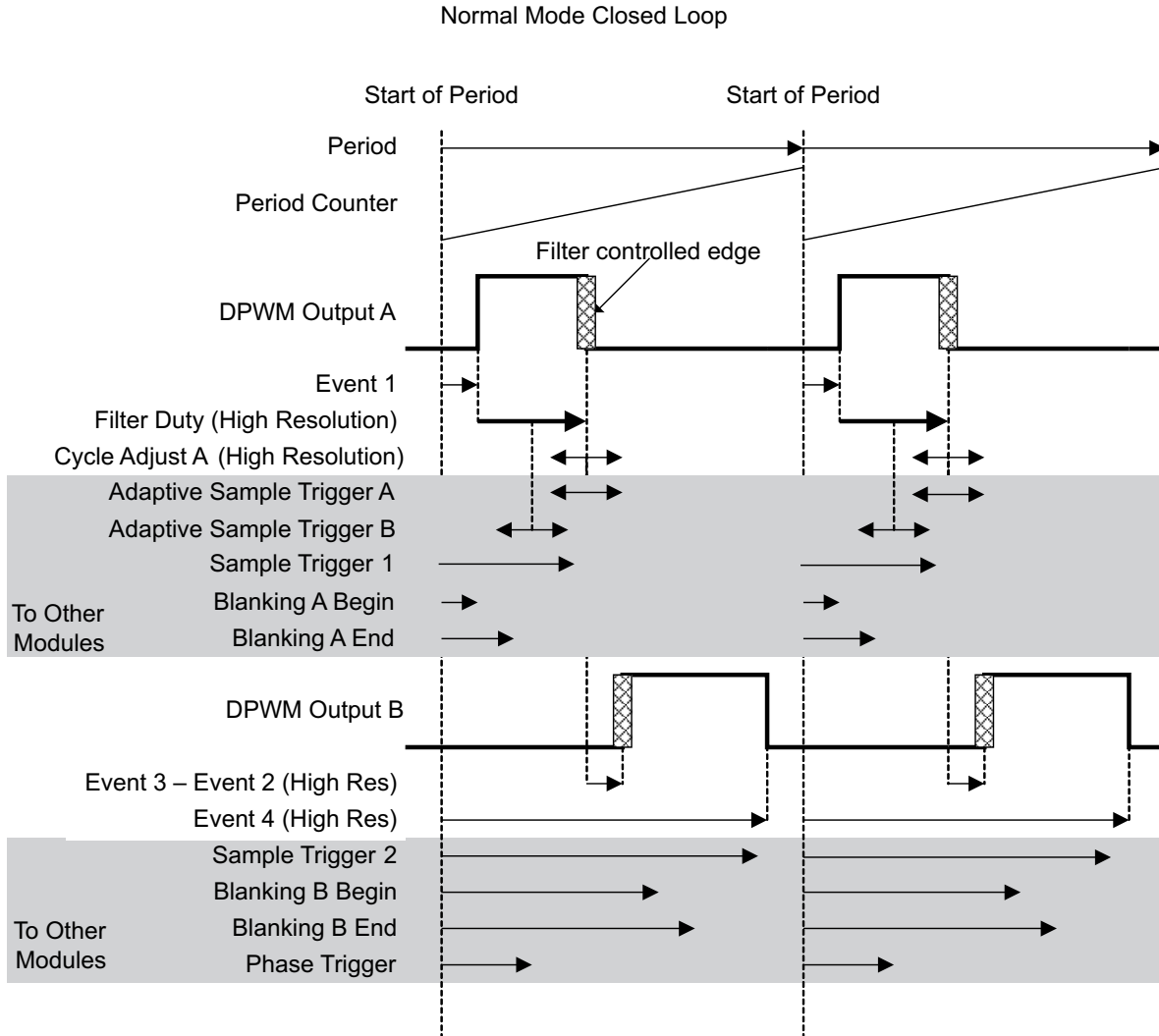

Events which change with DPWM mode:

DPWM A Rising Edge = Event 1

DPWM A Falling Edge = Event 1 + Filter Duty + Cycle Adjust A

Adaptive Sample Trigger A = Event 1 + Filter Duty + Adaptive Sample Register or

Adaptive Sample Trigger B = Event 1 + Filter Duty/2 + Adaptive Sample Register

DPWM B Rising Edge = Event 1 + Filter Duty + Cycle Adjust A + (Event 3 – Event 2)

DPWM B Falling Edge = Event 4

Phase Trigger = Phase Trigger Register value or Filter Duty

Events always set by their registers, regardless of mode:

Sample Trigger 1, Sample Trigger 2, Blanking A Begin, Blanking A End, Blanking B Begin, Blanking B End

Cycle adjust A can be used to adjust pulse widths on individual phases of a multi-phase system. This can be used for functions like current balancing. The Adaptive Sample Triggers can be used to sample in the middle of the on-time (for an average output), or at the end of the on-time (to minimize phase delay) The Adaptive Sample Register provides an offset from the center of the on-time. This can compensate for external delays, such as MOSFET and gate driver turn on times.

Blanking A-Begin and Blanking A-End can be used to blank out noise from the MOSFET turn on at the beginning of the period (DPWMA rising edge). Blanking B could be used at the turn off time of DPWMB. The other edges are dynamic, so blanking is more difficult.

Cycle Adjust B has no effect in Normal Mode.

#### 4.6 Phase Shifting

In most modes, it is possible to synchronize multiple DPWM modules using the phase shift signal. The phase shift signal has two possible sources. It can come from the Phase Trigger Register. This provides a fixed value, which is useful for an application like interleaved PFC.

The phase shift value can also come from the filter output. In this case, the changes in the filter output causes changes in the phase relationship of two DPWM modules. This is useful for phase shifted full bridge topologies.

The following figure shows the mechanism of phase shift:

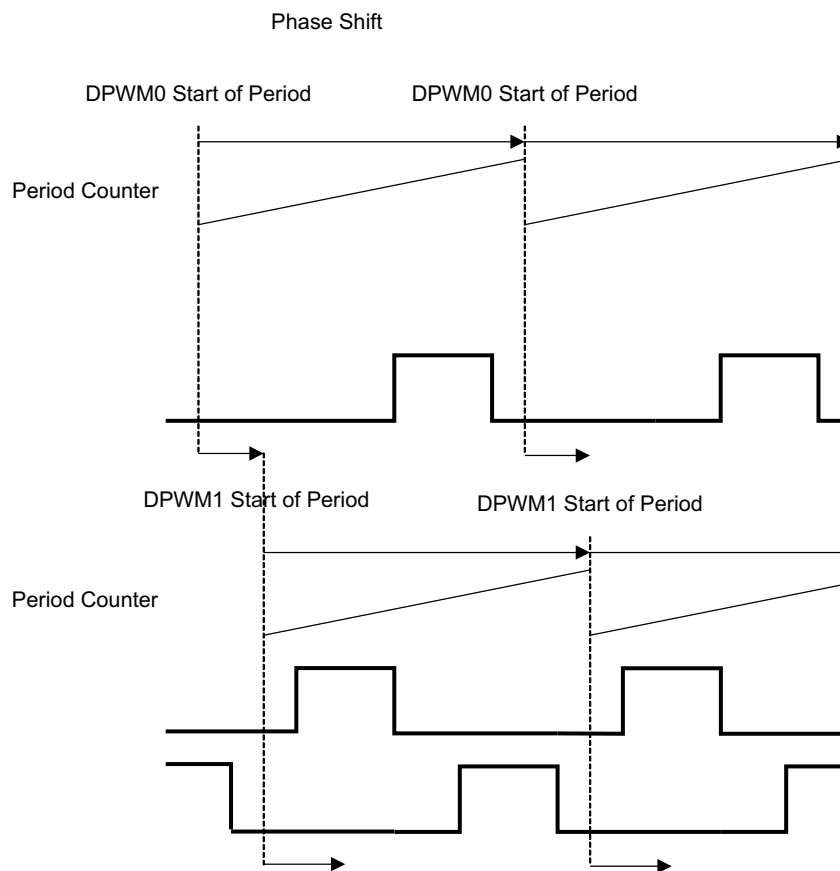

Phase Trigger = Phase Trigger Register value or Filter Duty

#### 4.7 DPWM Multiple Output Mode

Multi mode is used for systems where each phase has only one driver signal. It enables each DPWM peripheral to drive two phases with the same pulse width, but with a time offset between the phases, and with different cycle adjusts for each phase.

Here is a diagram for Multi-Mode:

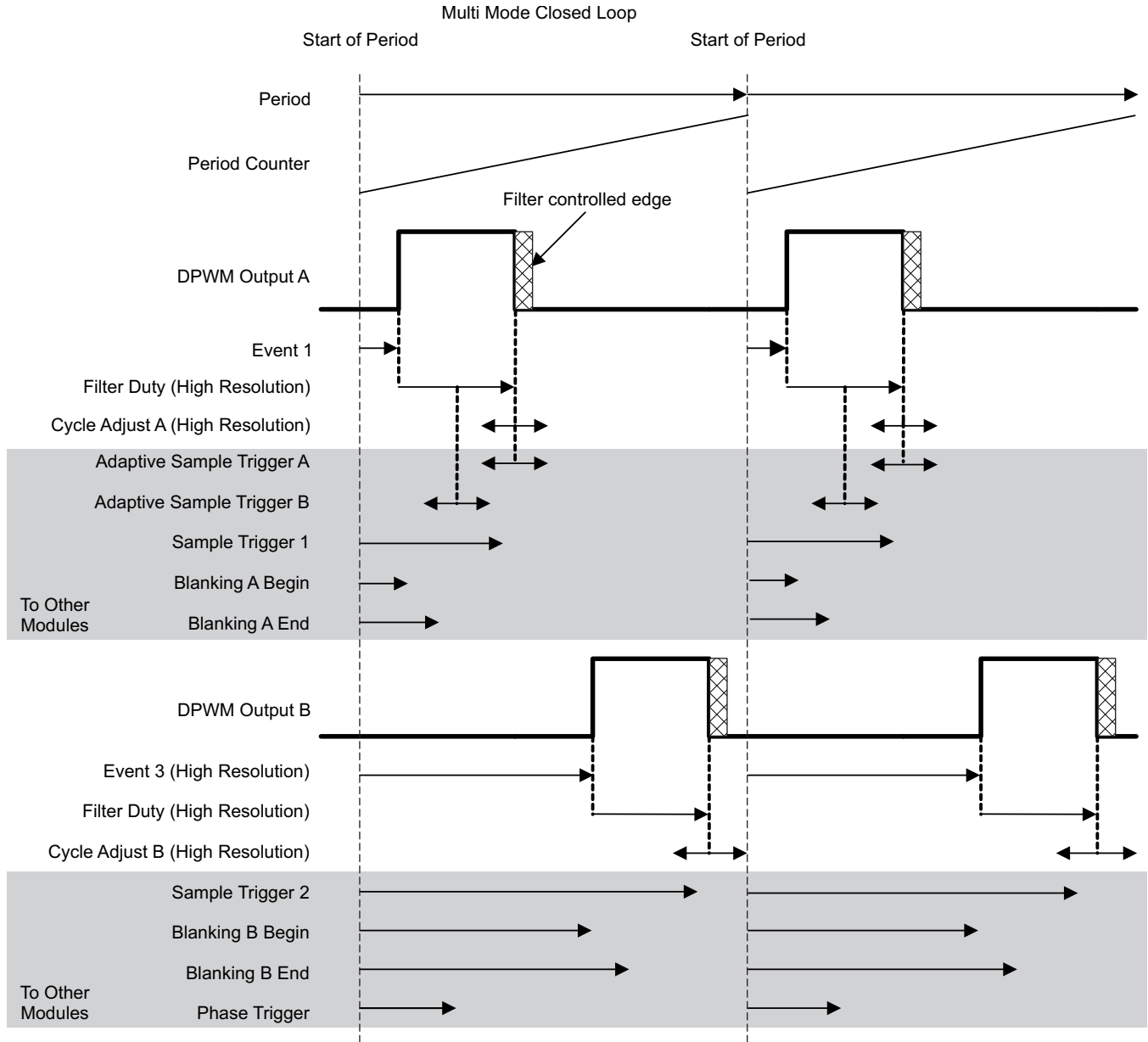

Events which change with DPWM mode:

- DPWM A Rising Edge = Event 1
- DPWM A Falling Edge = Event 1 + Filter Duty + Cycle Adjust A
- Adaptive Sample Trigger A = Event 1 + Filter Duty + Adaptive Sample Register or
- Adaptive Sample Trigger B = Event 1 + Filter Duty/2 + Adaptive Sample Register
- DPWM B Rising Edge = Event 3
- DPWM B Falling Edge = Event 3 + Filter Duty + Cycle Adjust B
- Phase Trigger = Phase Trigger Register value or Filter Duty

Events always set by their registers, regardless of mode:

- Sample Trigger 1, Sample Trigger 2, Blanking A Begin, Blanking A End, Blanking B Begin, Blanking B End

Event 2 and Event 4 are not relevant in Multi mode.

DPWMB can cross over the period boundary safely, and still have the proper pulse width, so full 100% pulse width operation is possible. DPWMA cannot cross over the period boundary.

Since the rising edge on DPWM B is also fixed, Blanking B-Begin and Blanking B-End can be used for blanking this rising edge.

And, of course, Cycle Adjust B is usable on DPWM B.

#### 4.8 DPWM Resonant Mode

This mode provides a symmetrical waveform where DPWMA and DPWMB have the same pulse width. As the switching frequency changes, the dead times between the pulses remain the same.

The equations for this mode are designed for a smooth transition from PWM mode to resonant mode, as described in the [LLC Example](#) section. Here is a diagram of this mode:

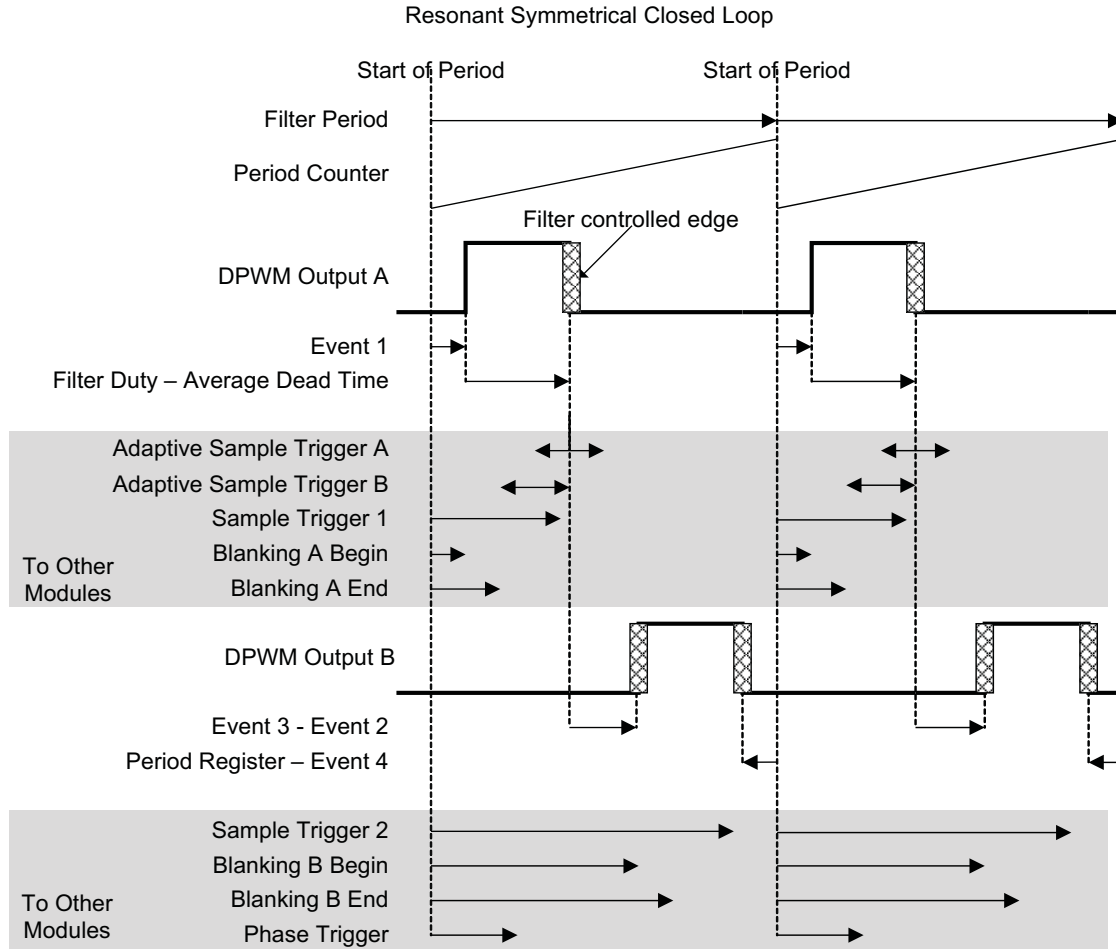

Events which change with DPWM mode:

$$\begin{aligned} \text{Dead Time 1} &= \text{Event 3} - \text{Event 2} \\ \text{Dead Time 2} &= \text{Event 1} + \text{Period Register} - \text{Event 4} \\ \text{Average Dead Time} &= (\text{Dead Time 1} + \text{Dead Time 2})/2 \end{aligned}$$

$$\begin{aligned} \text{DPWM A Rising Edge} &= \text{Event 1} \\ \text{DPWM A Falling Edge} &= \text{Event 1} + \text{Filter Duty} - \text{Average Dead Time} \\ \text{Adaptive Sample Trigger A} &= \text{Event 1} + \text{Filter Duty} + \text{Adaptive Sample Register} \\ \text{Adaptive Sample Trigger B} &= \text{Event 1} + \text{Filter Duty}/2 + \text{Adaptive Sample Register} \\ \text{DPWM B Rising Edge} &= \text{Event 1} + \text{Filter Duty} - \text{Average Dead Time} + (\text{Event 3} - \text{Event 2}) \\ \text{DPWM B Falling Edge} &= \text{Filter Period} - (\text{Period Register} - \text{Event 4}) \\ \text{Phase Trigger} &= \text{Phase Trigger Register value or Filter Duty} \end{aligned}$$

Events always set by their registers, regardless of mode:

Sample Trigger 1, Sample Trigger 2, Blanking A Begin, Blanking A End, Blanking B Begin, Blanking B End

The Filter has two outputs, Filter Duty and Filter Period. In this case, the Filter is configured so that the Filter Period is twice the Filter Duty. So if there were no dead times, each DPWM pin would be on for half of the period. For dead time handling, the average of the two dead times is subtracted from the Filter Duty for both DPWM pins. Therefore, both pins will have the same on-time, and the dead times will be fixed regardless of the period. The only edge which is fixed relative to the start of the period is the rising edge of DPWM A. This is the only edge for which the blanking signals can be used easily.

## 4.9 Triangular Mode

Triangular mode provides a stable phase shift in interleaved PFC and similar topologies. In this case, the PWM pulse is centered in the middle of the period, rather than starting at one end or the other. In Triangular Mode, only DPWM-B is available. Here is a diagram for Triangular Mode:

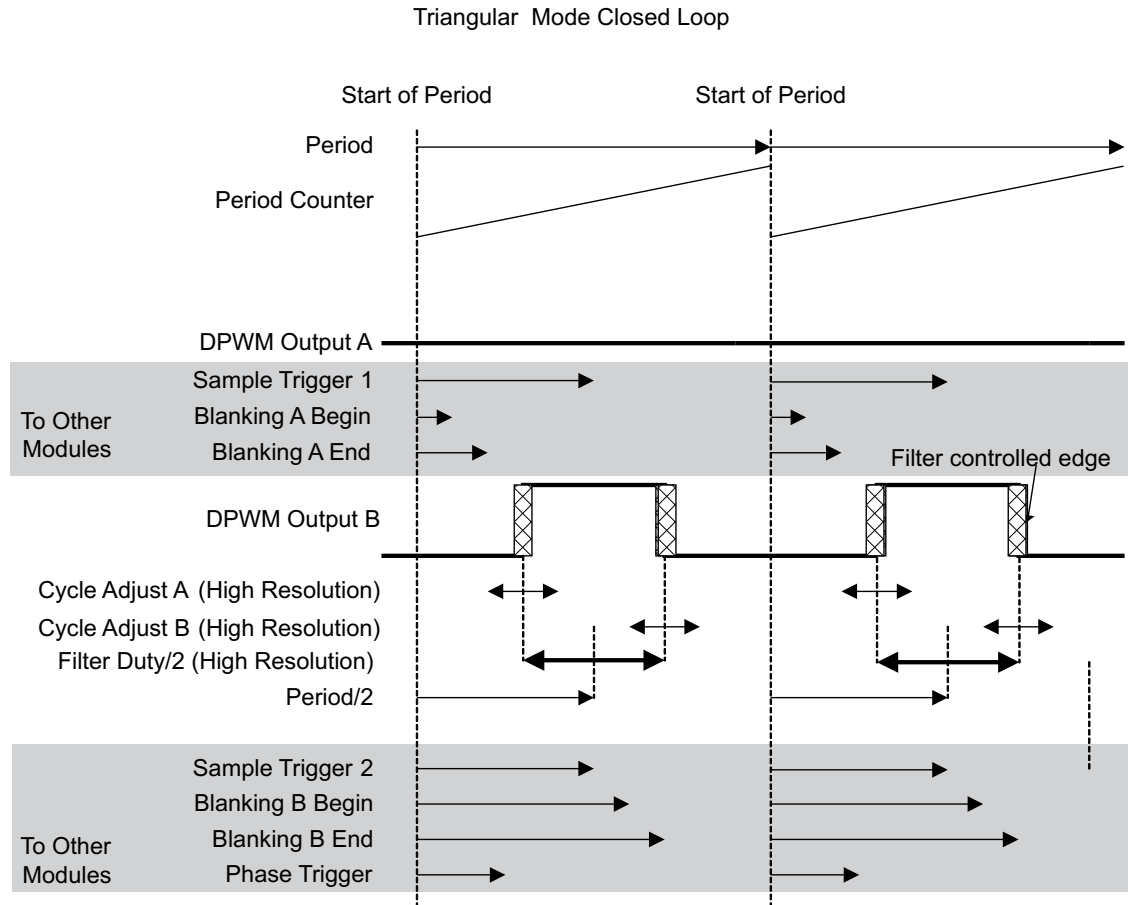

Events which change with DPWM mode:

DPWM A Rising Edge = None  
 DPWM A Falling Edge = None  
 Adaptive Sample Trigger = None  
 $DPWM\ B\ Rising\ Edge = Period/2 - Filter\ Duty/2 + Cycle\ Adjust\ A$   
 $DPWM\ B\ Falling\ Edge = Period/2 + Filter\ Duty/2 + Cycle\ Adjust\ B$   
 Phase Trigger = Phase Trigger Register value or Filter Duty

Events always set by their registers, regardless of mode:

Sample Trigger 1, Sample Trigger 2, Blanking A Begin, Blanking A End, Blanking B Begin, Blanking B End

All edges are dynamic in triangular mode, so fixed blanking is not that useful. The adaptive sample trigger is not needed. It is very easy to put a fixed sample trigger exactly in the center of the FET on-time, because the center of the on-time does not move in this mode.



#### 4.10 Leading Edge Mode

Leading edge mode is very similar to Normal mode, reversed in time. The DPWM A falling edge is fixed, and the rising edge moves to the left, or backwards in time, as the filter output increases. The DPWM B falling edge stays ahead of the DPWMA rising edge by a fixed dead time. Here is a diagram of the Leading Edge Mode:

## Leading Edge Closed Loop

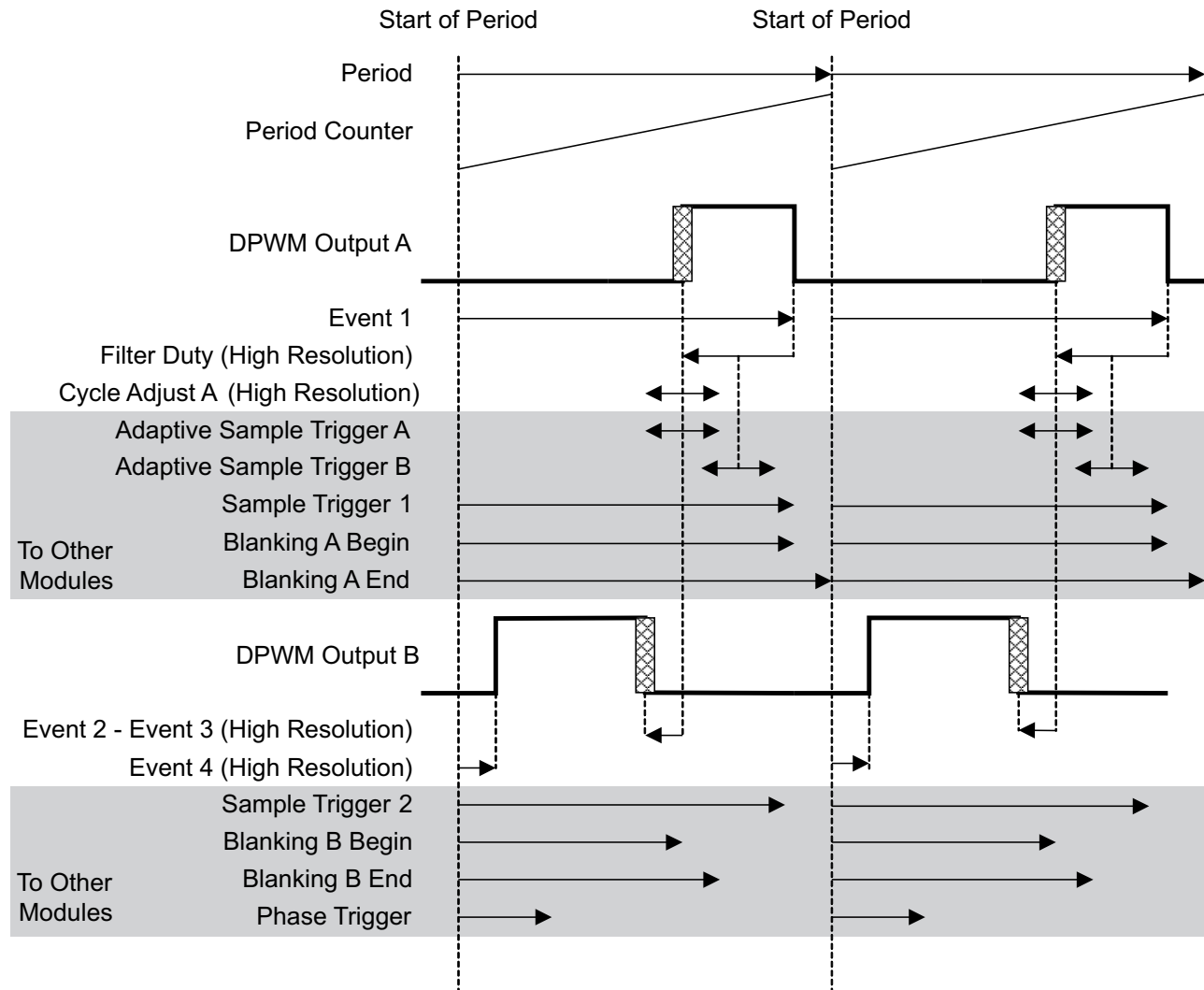

Events which change with DPWM mode:

DPWM A Falling Edge = Event 1  
 DPWM A Rising Edge = Event 1 - Filter Duty + Cycle Adjust A  
 Adaptive Sample Trigger A = Event 1 - Filter Duty + Adaptive Sample Register or  
 Adaptive Sample Trigger B = Event 1 - Filter Duty/2 + Adaptive Sample Register  
 DPWM B Rising Edge = Event 4  
 DPWM B Falling Edge = Event 1 - Filter Duty + Cycle Adjust A -(Event 2 – Event 3)  
 Phase Trigger = Phase Trigger Register value or Filter Duty

Events always set by their registers, regardless of mode:

Sample Trigger 1, Sample Trigger 2, Blanking A Begin, Blanking A End, Blanking B Begin, Blanking B End

As in the Normal mode, the two edges in the middle of the period are dynamic, so the fixed blanking intervals are mainly useful for the edges at the beginning and end of the period.

### 4.11 Synchronous Rectifier MOSFET Ramp and IDE Calculation

The UCD3138064 has built in logic for optimizing the performance of the synchronous rectifier MOSFETs. This comes in two forms:

- Synchronous Rectifier MOSFET ramp
- Ideal Diode Emulation (IDE) calculation

When starting up a power supply, It is not uncommon for there to already be a voltage present on the output – this is called pre-bias. It can be very difficult to calculate the ideal synchronous rectifier MOSFET on-time for this case. If it is not calculated correctly, it may pull down the pre-bias voltage, causing the power supply to sink current. To avoid this, the synchronous rectifier MOSFETs are not turned on until after the power supply has ramped up to the nominal output voltage. The synchronous rectifier MOSFETs are then turned on slowly in order to avoid an output voltage glitch. The synchronous rectifier MOSFET ramp logic can be used to turn them on at a rate well below the bandwidth of the filter.

In discontinuous mode, the ideal on-time for the synchronous rectifier MOSFETs is a function of  $V_{in}$ ,  $V_{out}$ , and the primary side duty cycle (D). The IDE logic in the UCD3138064 takes  $V_{in}$  and  $V_{out}$  data from the firmware and combines it with D data from the filter hardware. It uses this information to calculate the ideal on-time for the synchronous rectifier MOSFETs.

### 4.12 Automatic Mode Switching

Automatic Mode switching enables the DPWM module to switch between modes automatically, with no firmware intervention. This is useful to increase efficiency and power range. The following paragraphs describe phase-shifted full bridge and LLC examples.

#### 4.12.1 Phase Shifted Full Bridge Example

In phase shifted full bridge topologies, efficiency can be increased by using pulse width modulation, rather than phase shift, at light load. This is shown below:

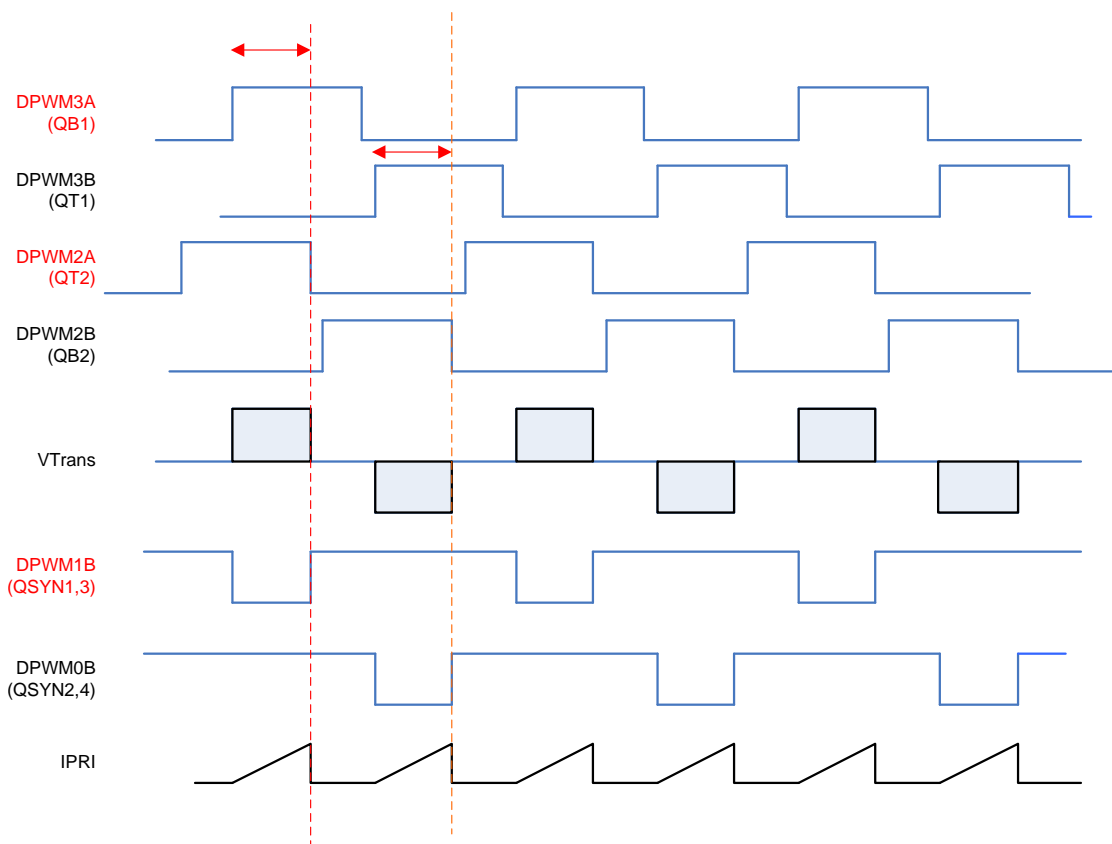

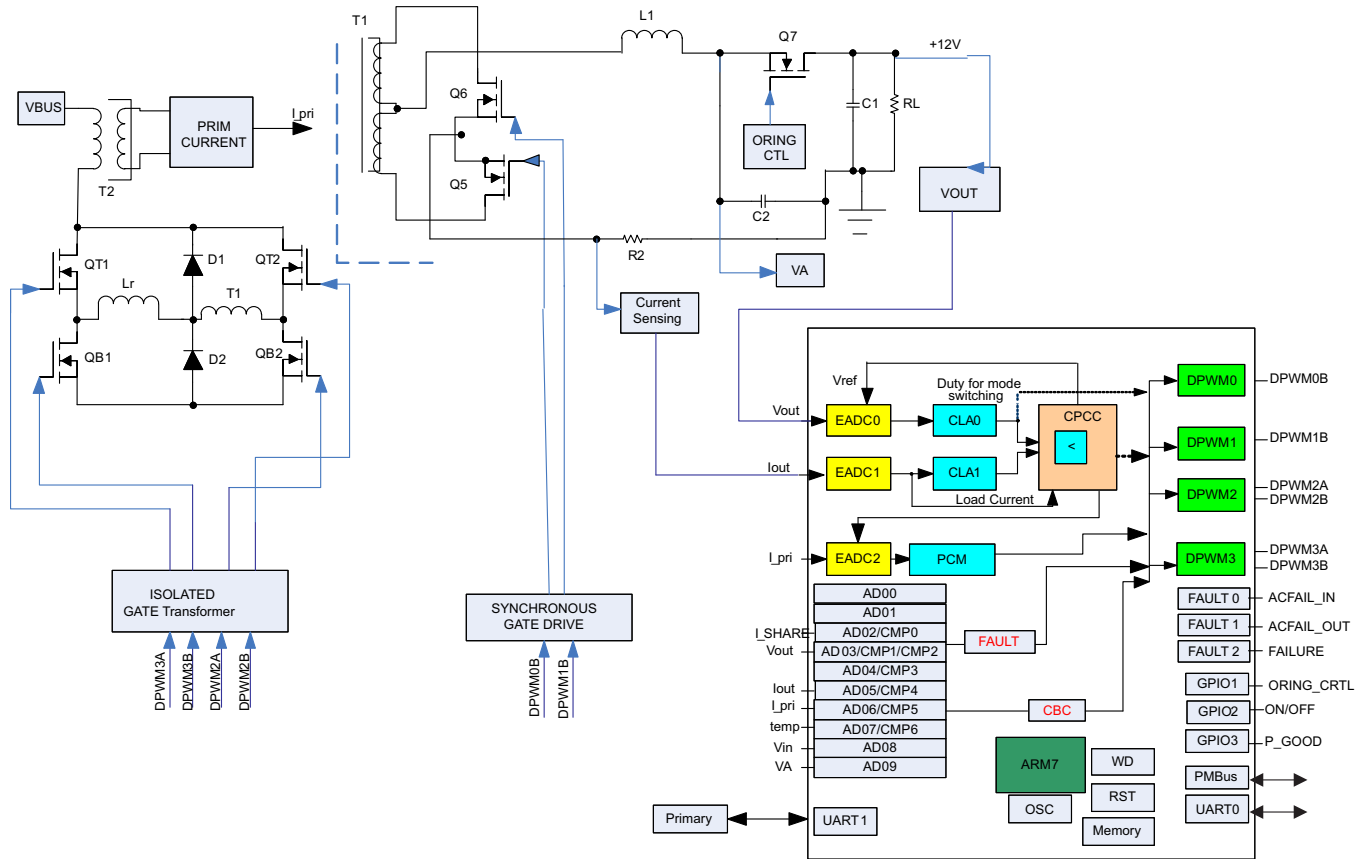
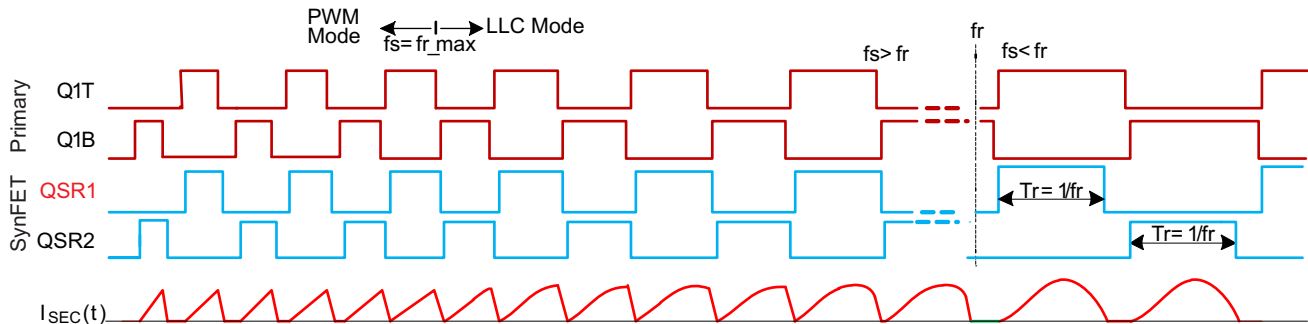

Figure 4-4. Secondary-Referenced Phase-Shifted Full Bridge Control With Synchronous Rectification

4.12.2 LLC Example

In LLC, three modes are used. At the highest frequency, a pulse width modulated mode (Multi Mode) is used. As the frequency decreases, resonant mode is used. As the frequency gets still lower, the synchronous MOSFET drive changes so that the on-time is fixed and does not increase. In addition, the LLC control supports cycle-by-cycle current limiting. This protection function operates by a comparator monitoring the maximum current during the DPWMA conduction time. Any time this current exceeds the programmable comparator reference the pulse is immediately terminated. Due to classic instability issues associated with half-bridge topologies it is also possible to force DPWMB to match the truncated pulse width of DPWMA. Here are the waveforms for the LLC:



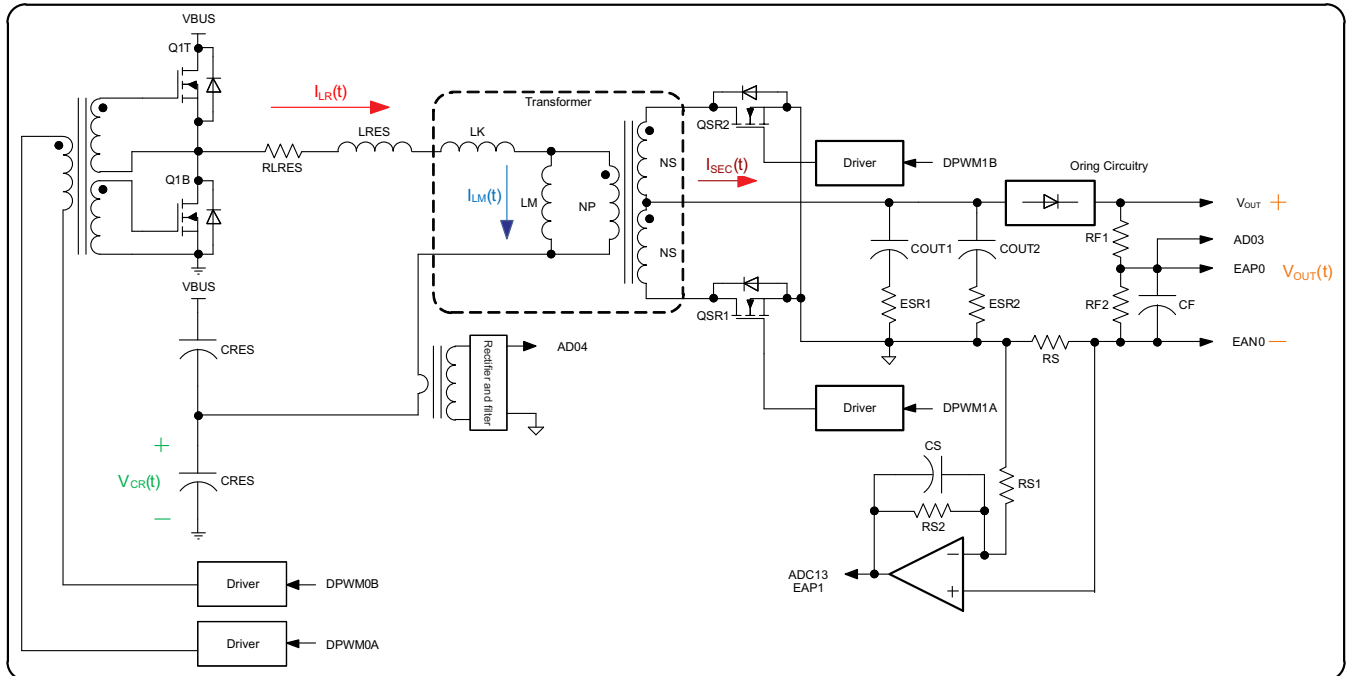
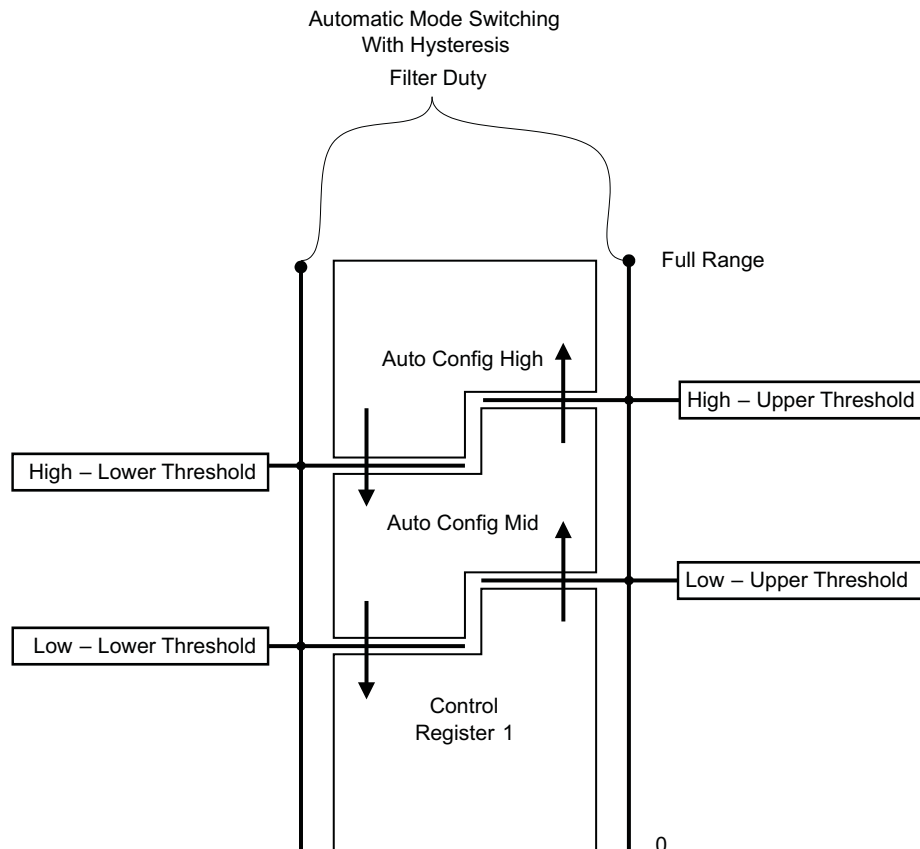

Figure 4-5. Secondary-Referenced Half-Bridge Resonant LLC Control With Synchronous Rectification

### 4.12.3 Mechanism for Automatic Mode Switching

The UCD3138064 allows the customer to enable up to two distinct levels of automatic mode switching. These different modes are used to enhance light load operation, short circuit operation and soft start. Many of the configuration parameters for the DPWM are in DPWM Control Register 1. For automatic mode switching, some of these parameters are duplicated in the Auto Config Mid and Auto Config High registers.

If automatic mode switching is enabled, the filter duty signal is used to select which of these three registers is used. There are 4 registers which are used to select the points at which the mode switching takes place. They are used as shown below.



As shown, the registers are used in pairs for hysteresis. The transition from Control Register 1 to Auto Config Mid only takes place when the Filter Duty goes above the Low Upper threshold. It does not go back to Auto Config Mid until the Low Lower Threshold is passed. This prevents oscillation between modes if the filter duty is close to a mode switching point.

### 4.13 DPWMC, Edge Generation, IntraMux

The UCD3138064 has hardware for generating complex waveforms beyond the simple DPWMA and DPWMB waveforms already discussed – DPWMC, the Edge Generation Module, and the IntraMux.

DPWMC is a signal inside the DPWM logic. It goes high at the Blanking A begin time, and low at the Blanking A end time.

The Edge Gen module takes DPWMA and DPWMB from its own DPWM module, and the next one, and uses them to generate edges for two outputs. For DPWM3, the DPWM0 is considered to be the next DPWM. Each edge (rising and falling for DPWMA and DPWMB) has 8 options which can cause it.

The options are:

- 0 = DPWM(n) A Rising edge
- 1 = DPWM(n) A Falling edge
- 2 = DPWM(n) B Rising edge
- 3 = DPWM(n) B Falling edge
- 4 = DPWM(n+1) A Rising edge
- 5 = DPWM(n+1) A Falling edge
- 6 = DPWM(n+1) B Rising edge
- 7 = DPWM(n+1) B Falling edge

Where “n” is the numerical index of the DPWM module of interest. For example n=1 refers to DPWM1.

The Edge Gen is controlled by the DPWMEDGEGEN register. It also has an enable/disable bit.

The IntraMux is controlled by the Auto Config registers. Intra Mux is short for intra multiplexer. The IntraMux takes signals from multiple DPWMs and from the Edge Gen and combines them logically to generate DPWMA and DPWMB signals. This is useful for topologies like phase-shifted full bridge, especially when they are controlled with automatic mode switching. Of course, it can all be disabled, and DPWMA and DPWMB will be driven as described in the sections above. If the Intra Mux is enabled, high resolution must be disabled, and DPWM edge resolution goes down to 4 ns.

Here is a drawing of the Edge Gen/Intra Mux:

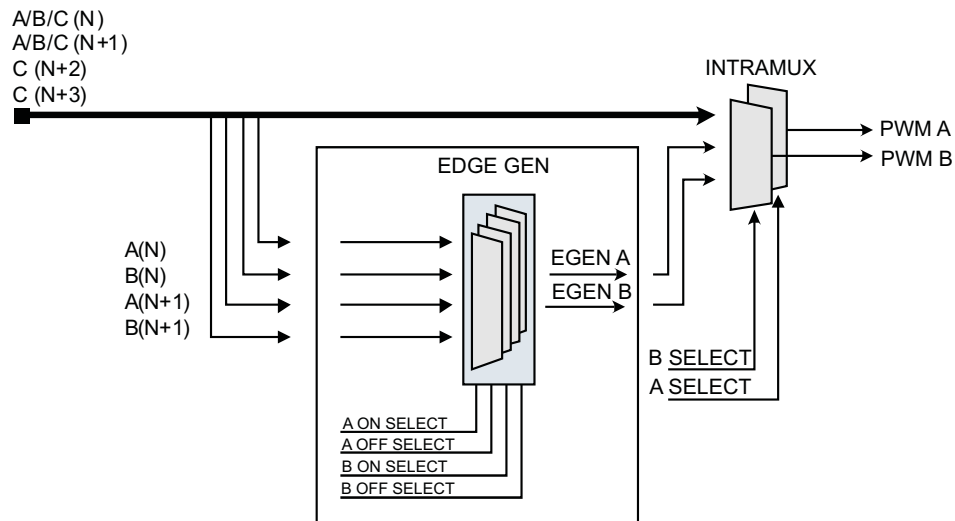

Here is a list of the IntraMux modes for DPWMA:

- 0 = DPWMA(n) pass through (default)
- 1 = Edge-gen output, DPWMA(n)
- 2 = DPWNC(n)
- 3 = DPWMB(n) (Crossover)
- 4 = DPWMA(n+1)

5 = DPWMB(n+1)

6 = DPWMC(n+1)

7 = DPWMC(n+2)

8 = DPWMC(n+3)

and for DPWMB:

0 = DPWMB(n) pass through (default)

1 = Edge-gen output, DPWMB(n)

2 = DPWNC(n)

3 = DPWMA(n) (Crossover)

4 = DPWMA(n+1)

5 = DPWMB(n+1)

6 = DPWMC(n+1)

7 = DPWMC(n+2)

8 = DPWMC(n+3)

The DPWM number wraps around just like the Edge Gen unit. For DPWM3 the following definitions apply:

DPWM(n)	DPWM3
DPWM(n+1)	DPWM0
DPWM(n+2)	DPWM1
DPWM(n+3)	DPWM2

#### 4.14 Filter

The UCD3138064 filter is a PID filter with many enhancements for power supply control. Some of its features include:

- Traditional PID Architecture
- Programmable non-linear limits for automated modification of filter coefficients based on received EADC error
- Multiple coefficient sets fully configurable by firmware
- Full 24-bit precision throughout filter calculations
- Programmable clamps on integrator branch and filter output
- Ability to load values into internal filter registers while system is running
- Ability to stall calculations on any of the individual filter branches
- Ability to turn off calculations on any of the individual filter branches
- Duty cycle, resonant period, or phase shift generation based on filter output.
- Flux balancing
- Voltage feed forward



Here is the first section of the Filter :

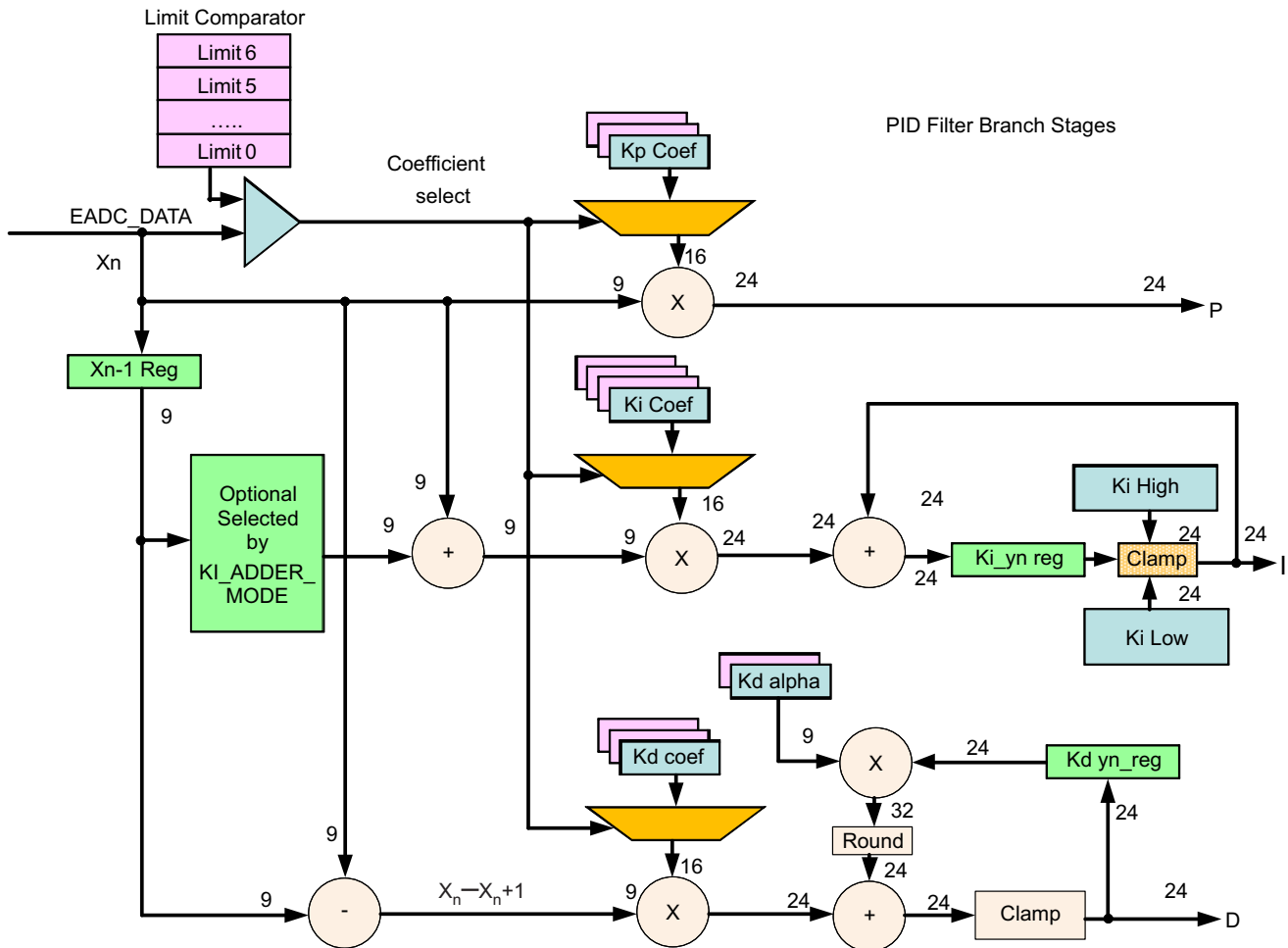

The filter input,  $X_n$ , generally comes from a front end. Then there are three branches, P, I, and D. Note that the D branch also has a pole,  $K_d$  Alpha. Clamps are provided both on the I branch and on the D alpha pole.

The filter also supports a nonlinear mode, where up to 7 different sets of coefficients can be selected depending on the magnitude of the error input  $X_n$ . This can be used to increase the filter gain for higher errors to improve transient response.

Here is the output section of the filter (S0.23 means that there is 1 sign bit, 0 integer bits and 23 fractional bits):

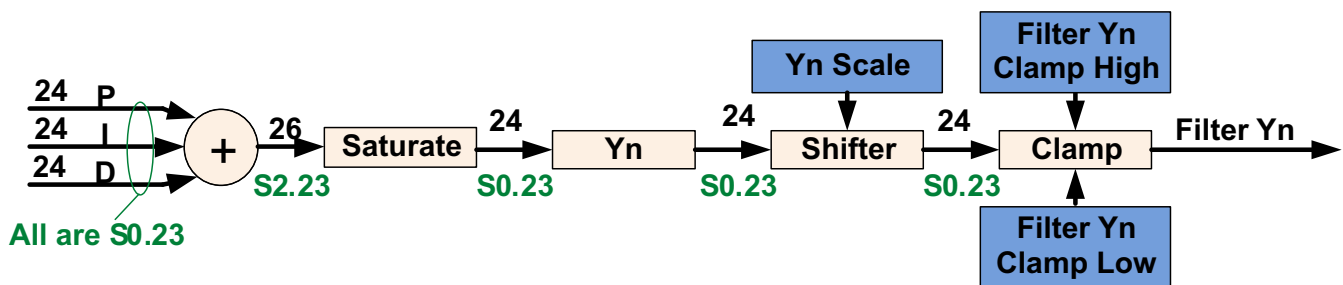

This section combines the P, I, and D sections, and provides for saturation, scaling, and clamping.

There is a final section for the filter, which permits its output to be matched to the DPWM:

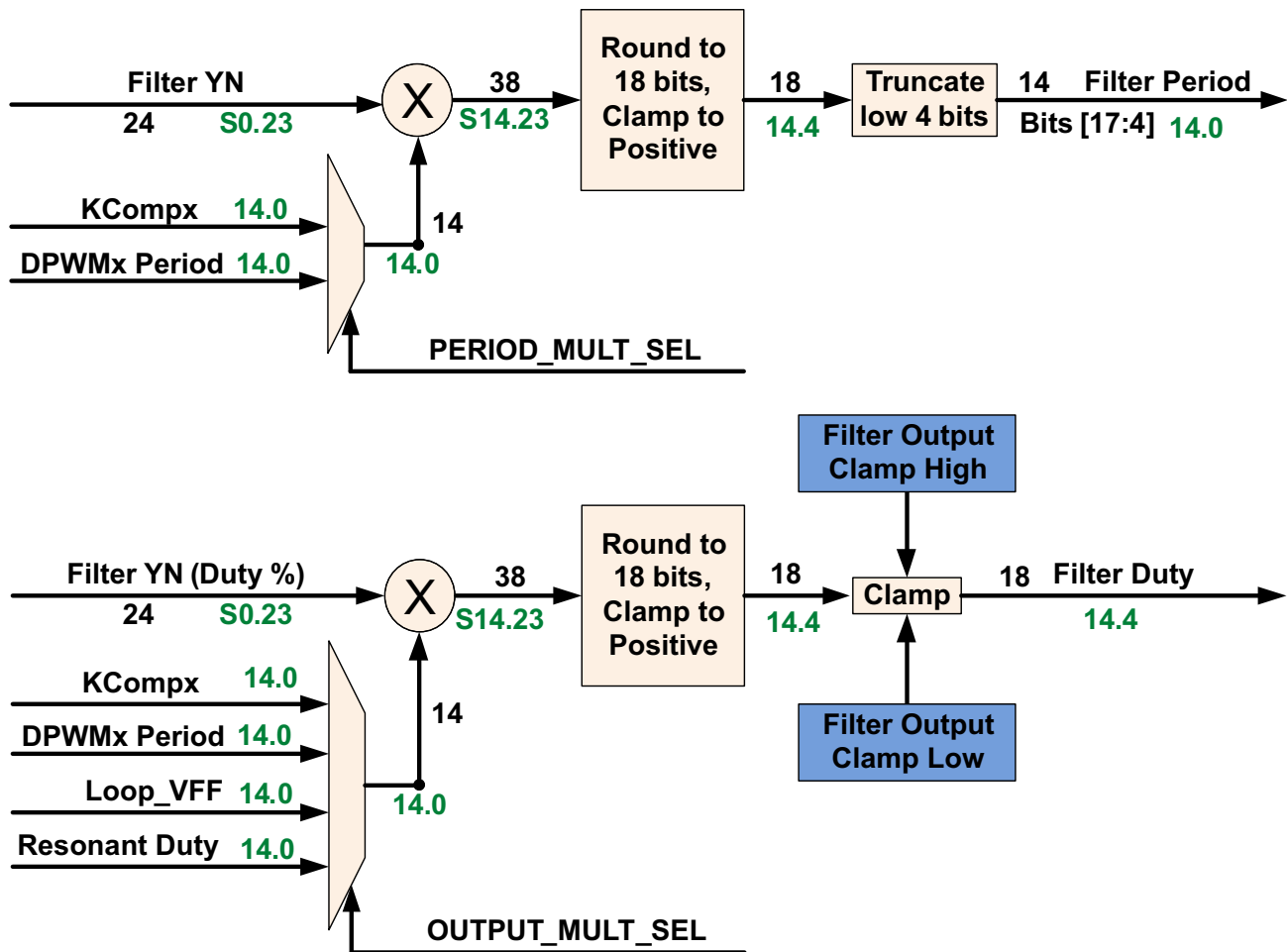

This permits the filter output to be multiplied by a variety of correction factors to match the DPWM Period, to provide for Voltage Feed Forward, or for other purposes. After this, there is another clamp. For resonant mode, the filter can be used to generate both period and duty cycle.

#### 4.14.1 Loop Multiplexer

The Loop Mux controls interconnections between the filters, front ends, and DPWMs. Any filter, front end, and DPWM can be combined in a variety of configurations.

It also controls the following connections:

- DPWM to Front End
- Front End DAC control from Filters or Constant Current/Constant Power Module
- Filter Special Coefficients and Feed Forward
- DPWM synchronization
- Filter to DPWM

The following control modules are configured in the Loop Mux:

- Constant Power/Constant Current
- Cycle Adjustment (Current and flux balancing)
- Global Period
- Light Load (Burst Mode)
- Analog Peak Current Mode

### 4.14.2 Fault Multiplexer

In order to allow a flexible way of mapping several fault triggering sources to all the DPWMs channels, the UCD3138064 provides an extensive array of multiplexers that are united under the name Fault Mux module.

The Fault Mux Module supports the following types of mapping between all the sources of fault and all the different fault response mechanisms inside each DPWM module.

- Many fault sources may be mapped to a single fault response mechanism. For instance an analog comparator in charge of over voltage protection, a digital comparator in charge of over current protection and an external digital fault pin can be all mapped to a Fault-A signal connected to a single FAULT MODULE and shut down DPWM1-A.
- A single fault source can be mapped to many fault response mechanisms inside many DPWM modules. For instance an analog comparator in charge of over current protection can be mapped to DPWM-0 through DPWM-3 by way of several fault modules.
- Many fault sources can be mapped to many fault modules inside many DPWM modules.

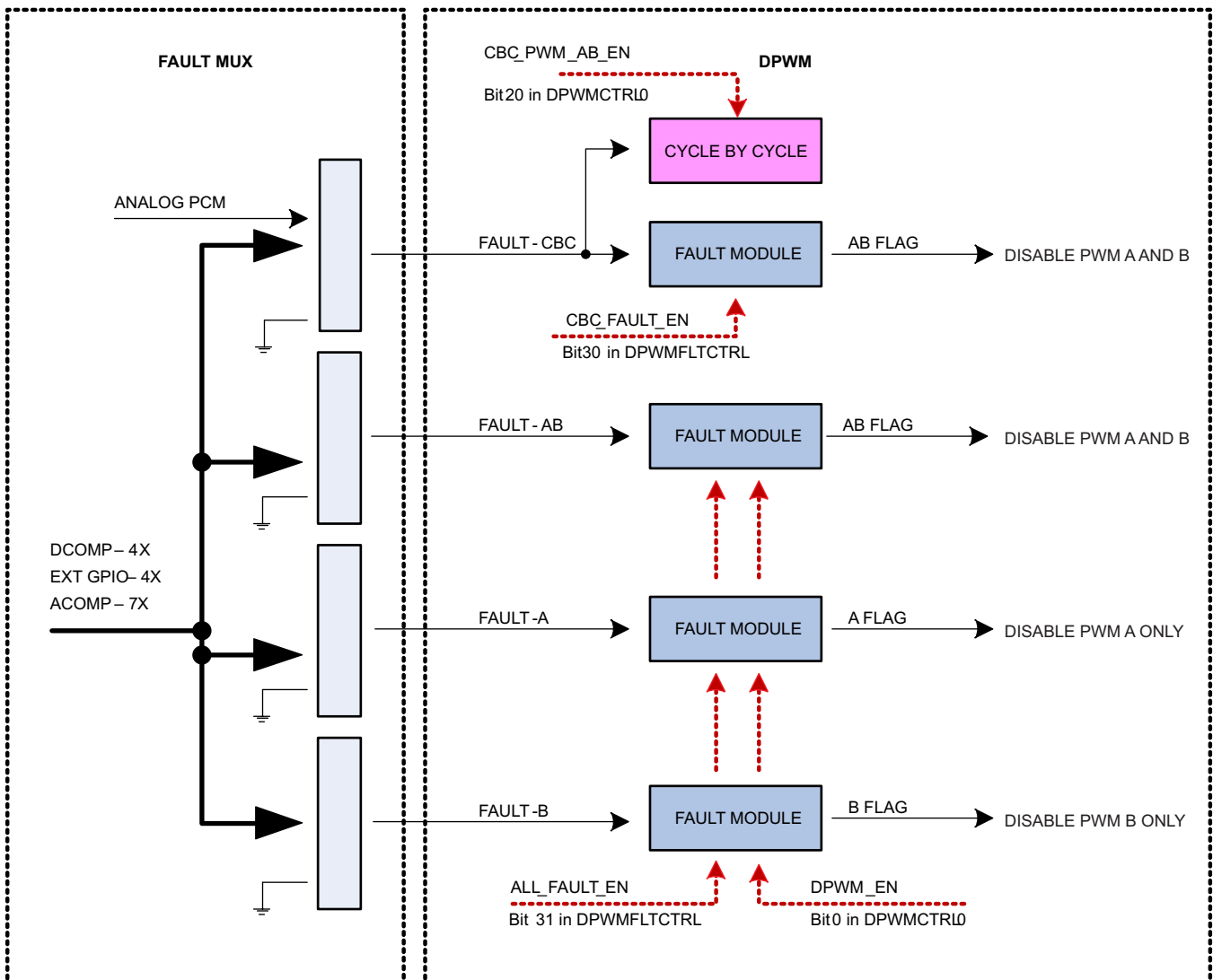

The Fault Mux Module provides a multitude of fault protection functions within the UCD3138064 high-speed loop (Front End Control, Filter, DPWM and Loop Mux modules). The Fault Mux Module allows highly configurable fault generation based on digital comparators, high-speed analog comparators and external fault pins. Each of the fault inputs to the DPWM modules can be configured to one or any combination of the fault events provided in the Fault Mux Module.

Each one of the DPWM engines has four fault modules. The modules are called CBC fault module, AB fault module, A fault module and B fault module.

The internal circuitry in all the four fault modules is identical, and the difference between the modules is limited to the way the modules are attached to the DPWMs.

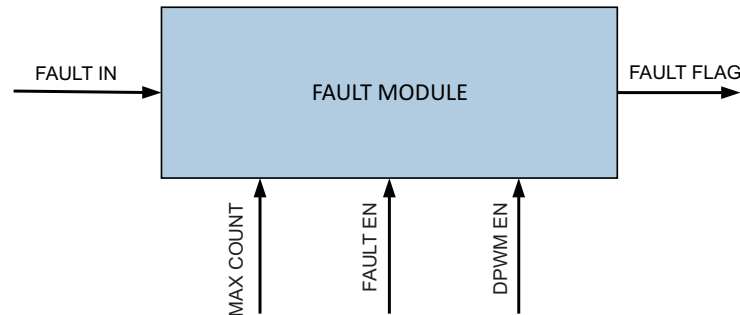

All fault modules provide immediate fault detection but only once per DPWM switching cycle. Each one of the fault modules own a separate max\_count and the fault flag will be set only if sequential cycle-by-cycle fault count exceeds max\_count.

Once the fault flag is set, DPWMs need to be disabled by DPWM\_EN going low in order to clear the fault flags. Please note, all four Fault Modules share the same DPWM\_EN control, all fault flags (output of Fault Modules) will be cleared simultaneously.

All four Fault Modules share the same global FAULT\_EN as well. Therefore a specific Fault Module cannot be enabled/ disabled separately.

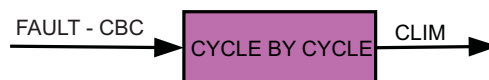

Unlike Fault Modules, only one Cycle by Cycle block is available in each DPWM module.

The Cycle by Cycle block works in conjunction with CBC Fault Module and enables DPWM reaction to signals arriving from the Analog Peak current mode (PCM) module.

The Fault Mux Module supports the following basic functions:

- 4 digital comparators with programmable thresholds and fault generation
- Configuration for 7 high speed analog comparators with programmable thresholds and fault generation
- External GPIO detection control with programmable fault generation
- Configurable DPWM fault generation for DPWM Current Limit Fault, DPWM Over-Voltage Detection Fault, DPWM A External Fault, DPWM B External Fault and DPWM IDE Flag
- Clock Failure Detection for High and Low Frequency Oscillator blocks
- Discontinuous Conduction Mode Detection

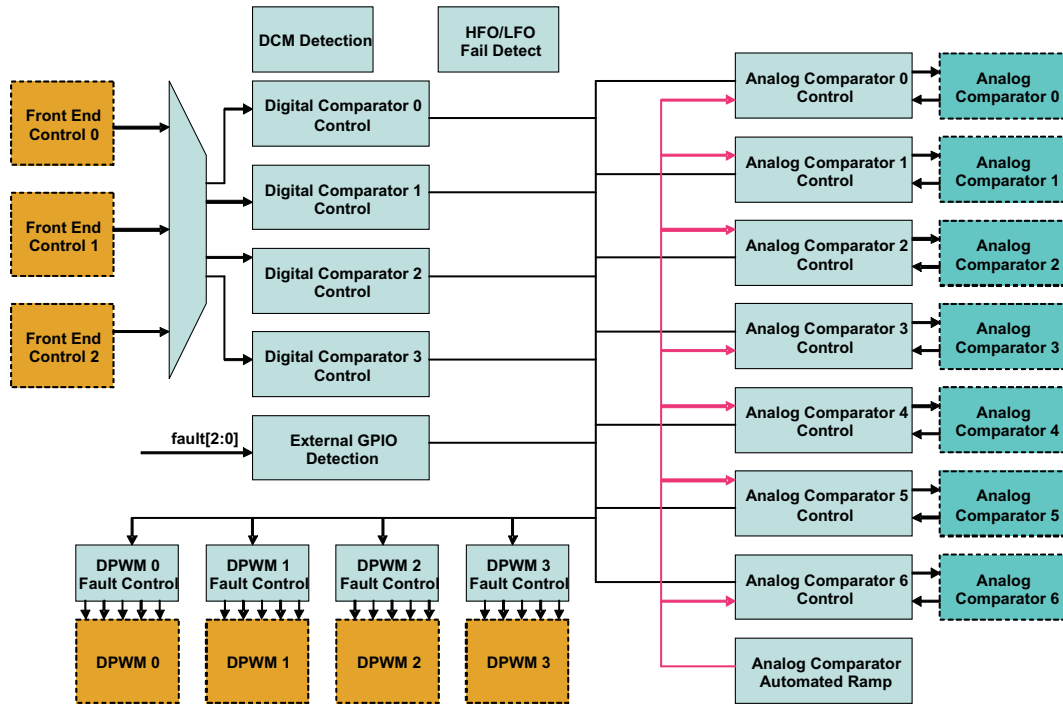

Figure 4-6. Fault Mux Block Diagram

## 4.15 Communication Ports

### 4.15.1 SCI (UART) Serial Communication Interface

A maximum of two independent Serial Communication Interface (SCI) or Universal Asynchronous Receiver/Transmitter (UART) interfaces are included within the device for asynchronous start-stop serial data communication (see the pin out sections for details). Each interface has a 24 bit pre-scaler for supporting programmable baud rates, a programmable data word and stop bit options. Half or full duplex operation is configurable through register bits. A loop back feature can also be setup for firmware verification. Both SCI-TX and SCI-RX pin sets can be used as GPIO pins when the peripheral is not being used.

### 4.15.2 PMBUS

The PMBus Interface supports independent master and slave modes controlled directly by firmware through a processor bus interface. Individual control and status registers enable firmware to send or receive I<sup>2</sup>C, SMBus or PMBus messages in any of the accepted protocols, in accordance with the I<sup>2</sup>C Specification, SMBus Specification (Version 2.0) and the PMBUS Power System Management Protocol Specification.

The PMBus interface is controlled through a processor bus interface, utilizing a 32-bit data bus and 6-bit address bus. The PMBus interface is connected to the expansion bus, which features 4 byte write enables, a peripheral select dedicated for the PMBus interface, separated 32-bit data buses for reading and writing of data and active-low write and output enable control signals. In addition, the PMBus Interface connects directly to the I<sup>2</sup>C/SMBus/PMBus Clock, Data, Alert, and Control signals.

#### Example: PMBus Address Decode via ADC12 Reading

The user can allocate 2 pins of the 12-bit ADC input channels, AD\_00 and AD\_01, for PMBus address decoding. At power-up the device applies I<sub>BIAS</sub> to each address detect pin and the voltage on that pin is captured by the internal 12-bit ADC.

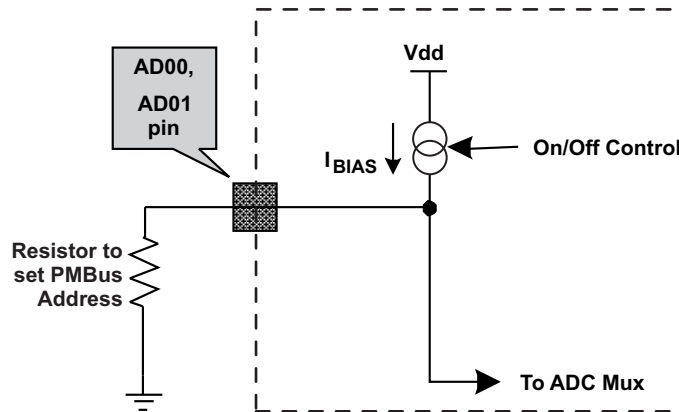

**Figure 4-7. PMBus Address Detection Method**

### 4.15.3 I<sup>2</sup>C

The bidirectional I<sup>2</sup>C bus consists of the serial clock (SCL) and serial data (SDA) lines. Both lines must be connected to a positive supply through a pullup resistor. Data transfer may be initiated only when the bus is not busy. I<sup>2</sup>C communication is initiated by the master sending a start condition, a high-to-low transition on the SDA input/output while the SCL input is high. After the start condition, the device address byte is sent, most significant bit (MSB) first, including the data direction bit (R/W). After receiving the valid address byte, this device responds with an acknowledge (ACK), a low on the SDA input/output during the high of the ACK-related clock pulse. On the I<sup>2</sup>C bus, only one data bit is transferred during each clock pulse. The data on the SDA line must remain stable during the high pulse of the clock period, as changes in the data line at this time are interpreted as control commands (start or stop). A stop condition, a low-to-high transition on the SDA input/output while the SCL input is high, is sent by the master. Any number of data bytes can be transferred from the transmitter to receiver between the start and the stop conditions. Each byte of eight bits is followed by one ACK bit. The transmitter must release the SDA line before the receiver can send an ACK bit. The device that acknowledges must pull down the SDA line during the ACK clock pulse so that the SDA line is stable low during the high pulse of the ACK-related clock period. When a slave receiver is addressed, it must generate an ACK after each byte is received. Similarly, the master must generate an ACK after each byte that it receives from the slave transmitter. Setup and hold times must be met to ensure proper operation. A master receiver signals an end of data to the slave transmitter by not generating an acknowledge (NACK) after the last byte has been clocked out of the slave. This is done by the master receiver by holding the SDA line high. In this event, the transmitter must release the data line to enable the master to generate a stop condition. This I<sup>2</sup>C operates as a master only.

### 4.15.4 SPI

The SPI is a high-speed synchronous serial input/output port that allows a serial bit stream of programmed length (1 to 16 bits) to be shifted into and out of the device at a programmed bit-transfer rate. The SPI is normally used for communication between the UCD3138064 and external peripherals. Typical applications include an interface to external I/O or peripheral expansion via devices such as shift registers, display drivers, SPI EPROMs and analog-to-digital converters. The SPI allows serial communication with other SPI devices through a 3-pin or 4-pin mode interface. The device implementation supports multichip-select operation for up to two SPI slave devices. The SPI typically is configured as a master for communicating to external EEPROM.

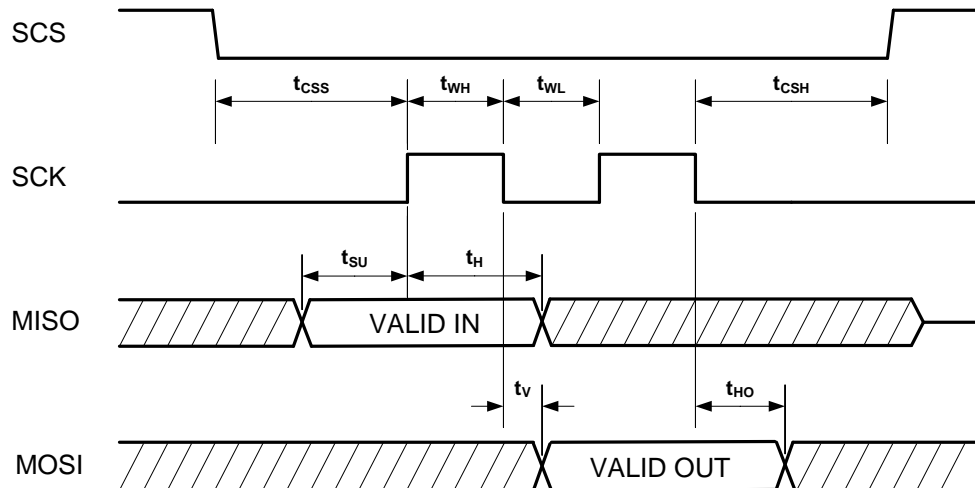

$P_{SCK}$	<b>Period SCK</b>	<b>2 ICLK</b>
$t_{WH}$	<b>SCK High Time</b>	<b>1/2 <math>P_{SCK}</math></b>
$t_{WL}$	<b>SCK Low Time</b>	<b>1/2 <math>P_{SCK}</math></b>
$t_{SU}$	<b>Data in setup</b>	<b>2 ns (typical)</b>
$t_H$	<b>Data in hold</b>	<b>4 ns (typical)</b>
$t_V$	<b>Output Valid</b>	<b>4 ns (typical)</b>
$t_{HO}$	<b>Output Data Hold</b>	<b>2 ns (typical)</b>
$t_{CSS}$	<b>Chip Select Setup</b>	<b>1 <math>P_{SCK}</math></b>
$t_{CSH}$	<b>Chip Select Hold</b>	<b>1 <math>P_{SCK}</math></b>

Figure 4-8. SPI Timing Diagram

## 4.16 Timers

External to the Digital Power Peripherals there are 3 different types of timers in UCD3138064. They are the 24-bit timer, 16-bit timer and the watchdog timer

### 4.16.1 24-bit PWM Timer

There is one 24 bit counter PWM timer which runs off the Interface Clock and can further be divided down by an 8-bit pre-scalar to generate a slower PWM time period. The timer has two compare registers (Data Registers) for generating the PWM set/unset events. Additionally, the timer has a shadow register (Data Buffer register) which can be used to store CPU updates of the compare events while still using the timer. The selected shadow register update mode happens after the compare event matches.

The two capture pins TCMP0 and TCMP1 are inputs for recording a capture event. A capture event can be set either to rising, falling, or both edges of the capture pin. Upon this event, the counter value is stored in the corresponding capture data register.

The counter reset can be configured to happen on a counter roll over, a compare equal event, or by software controlled register. Five Interrupts from the PWM timer can be set, which are the counter rollover event (overflow), either capture event 0 or 1, or the two comparison match events. Each interrupt can be disabled or enabled.

Upon an event comparison on only the second event, the TCMP pin can be configured to set, clear, toggle or have no action at the output. The value of PWM pin output can be read for status or simply configured as general purpose I/O for reading the value of the input at the pin. The first compare event can only be used as an interrupt.

### 4.16.2 16-Bit PWM Timers

There are four 16 bit counter PWM timers which run off the Interface Clock and can further be divided down by a 8-bit pre-scaler to generate slower PWM time periods. Each timer has two compare registers (Data Registers) for generating the PWM set/unset events. Additionally, each timer has a shadow register (Data Buffer register) which can be used to store CPU updates of compare events while still using the timer. The selected shadow register update mode happens after the compare event matches.

The counter reset can be configured to happen on a counter roll over, a compare equal event, or by a software controlled register. Interrupts from the PWM timer can be set due to the counter rollover event (overflow) or by the two comparison match events. Each comparison match and the overflow interrupts can be disabled or enabled.

Upon an event comparison, the PWM pin can be configured to set, clear, toggle or have no action at the output. The value of PWM pin output can be read for status or simply configured as General Purpose I/O for reading the value of the input at the pin.

### 4.16.3 Watchdog Timer

A watchdog timer is provided on the device for ensuring proper firmware loop execution. The timer is clocked off of a separate low speed oscillator source. If the timer is allowed to expire, a reset condition is issued to the ARM processor. The watchdog is reset by a simple CPU write bit to the watchdog key register by the firmware routine. On device power-up the watchdog is disabled. Yet after it is enabled, the watchdog cannot be disabled by firmware. Only a device reset can put this bit back to the default disabled state. A half timer flag is also provided for status monitoring of the watchdog.

## 4.17 General Purpose ADC12

The ADC12 is a 12 bit, high speed analog to digital converter, equipped with the following options:

- Typical conversion speed of 267 ksp/s
- Conversions can consist from 1 to 16 ADC channel conversions in any desired sequence
- Post conversion averaging capability, ranging from 4X, 8X, 16X or 32X samples
- Configurable triggering for ADC conversions from the following sources: firmware, DPWM rising edge, ADC\_EXT\_TRIG pin or Analog Comparator results
- Interrupt capability to embedded processor at completion of ADC conversion
- Six digital comparators on the first 6 channels of the conversion sequence using either raw ADC data or averaged ADC data
- Two 10  $\mu$ A current sources for excitation of PMBus addressing resistors
- Dual sample and hold for accurate power measurement
- Internal temperature sensor for temperature protection and monitoring

The control module ( [ADC12 Control Block Diagram](#)) contains the control and conversion logic for auto-sequencing a series of conversions. The sequencing is fully configurable for any combination of 16 possible ADC channels through an analog multiplexer embedded in the ADC12 block. Once converted, the selected channel value is stored in the result register associated with the sequence number. Input channels can be sampled in any desired order or programmed to repeat conversions on the same channel multiple times during a conversion sequence. Selected channel conversions are also stored in the result registers in order of conversion, where the result 0 register is the first conversion of a 16-channel sequence and result 15 register is the last conversion of a 16-channel sequence. The number of channels converted in a sequence can vary from 1 to 16.

Unlike EADC0 through EADC2, which are primarily designed for closing high speed compensation loops, the ADC12 is not usually used for loop compensation purposes. The EADC converters have a substantially faster conversion rate, thus making them more attractive for closed loop control. The ADC12 features make it best suited for monitoring and detection of currents, voltages, temperatures and faults. Please see the [Typical Characteristics plots](#) for the temperature variation associated with this function.



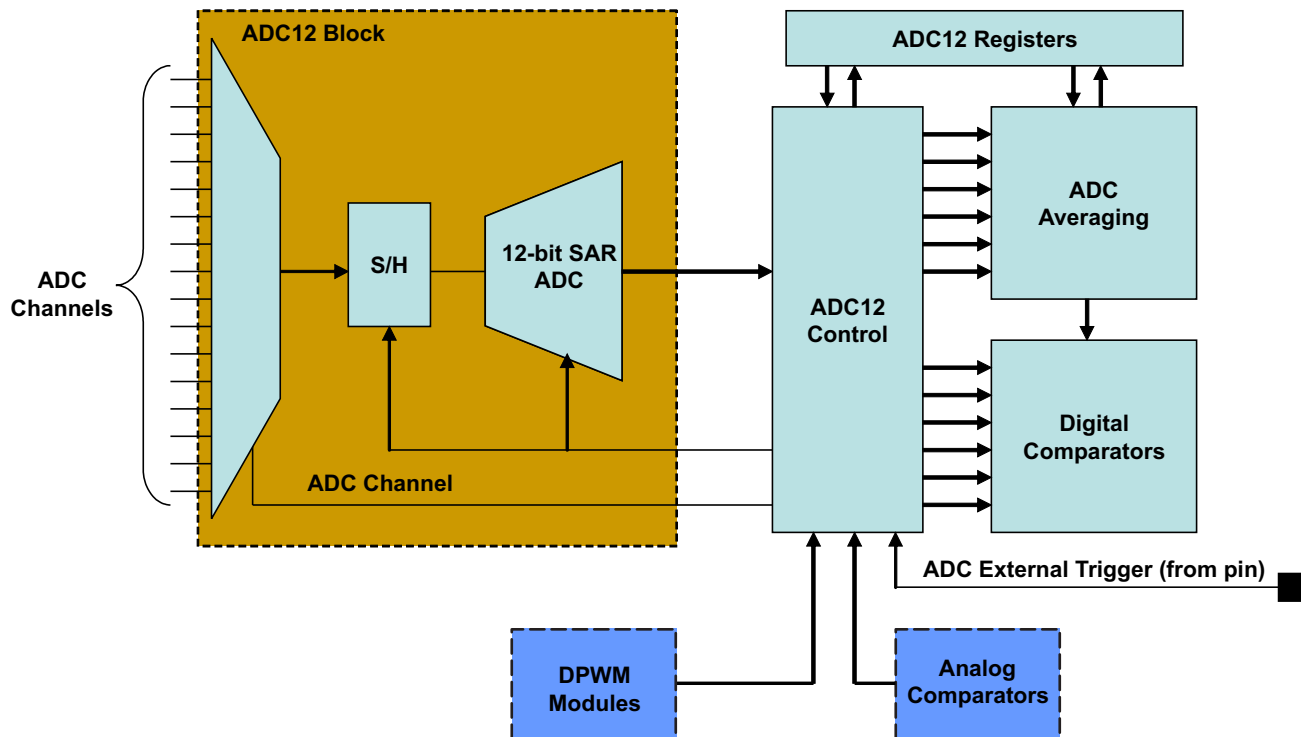

Figure 4-9. ADC12 Control Block Diagram

#### 4.18 Miscellaneous Analog

The Miscellaneous Analog Control (MAC) Registers are a catch-all of registers that control and monitor a wide variety of functions. These functions include device supervisory features such as Brown-Out and power saving configuration, general purpose input/output configuration and interfacing, internal temperature sensor control and current sharing control.

The MAC module also provides trim signals to the oscillator and AFE blocks. These controls are usually used at the time of trimming at manufacturing; therefore this document will not cover these trim controls.

The MAC registers and peripherals are all available in the UCD3138064 (64 pin version). Other UCD3138064 devices may have reduced resources. See the device pin out description for details.

#### 4.19 Package ID Information

Package ID register includes information regarding the package type of the device and can be read by firmware for reporting through PMBus or for other package sensitive decisions.

<b>BIT NUMBER</b>	<b>1:0</b>
<b>Bit Name</b>	PKG_ID
<b>Access</b>	R/W
<b>Default</b>	0 – UCD3138064RGC, 1 – UCD3138064RHA

#### 4.20 Brownout

Brownout function is used to determine if the device supply voltage is lower than a threshold voltage, a condition that may be considered unsafe for proper operation of the device.

The brownout threshold is higher than the reset threshold voltage; therefore, when the supply voltage is lower than brownout threshold, it still does not necessarily trigger a device reset.

The brownout interrupt flag can be polled or alternatively can trigger an interrupt to service such case by an interrupt service routine. Please see the [Power On Reset \(POR\) / Brown Out Reset \(BOR\)](#) section.

#### 4.21 Global I/O

Up to 30 pins in UCD3138064 can be configured to serve as a general purpose input or output pin (GPIO). This includes all digital input or output pins except for the RESET pin.

The pins that cannot be configured as GPIO pins are the supply pins, ground pins, ADC-12 analog input pins, EADC analog input pins and the RESET pin.

There are two ways to configure and use the digital pins as GPIO pins:

1. Through the centralized Global I/O control registers.
2. Through the distributed control registers in the specific peripheral that shares it pins with the standard GPIO functionality.

The Global I/O registers offer full control of:

1. Configuring each pin as a GPIO.
2. Setting each pin as input or output.
3. Reading the pin's logic state, if it is configured as an input pin.
4. Setting the logic state of the pin, if it is configured as an output pin.
5. Connecting pin/pins to high rail through internal pull up resistors.

The Global I/O registers include Global I/O EN register, Global I/O OE Register, Global I/O Open Drain Control Register, Global I/O Value Register and Global I/O Read Register.

The following is showing the format of Global I/O EN Register (GLBIOEN) as an example:

<b>BIT NUMBER</b>	<b>29:0</b>
<b>Bit Name</b>	GLOBAL_IO_EN
<b>Access</b>	R/W
<b>Default</b>	00_0000_0000_0000_0000_0000_0000_0000

**Bits 29-0: GLOBAL\_IO\_EN** – This register enables the global control of digital I/O pins  
 0 = Control of IO is done by the functional block assigned to the IO (Default)  
 1 = Control of IO is done by Global IO registers.

BIT	PIN_NAME	PIN NUMBER	
		UCD3138064-64 PIN	UCD3138064-48 PIN
29	FAULT3	43	N/A
28	ADC_EXT	12	8
27	TCK	37	27
26	TDO	38	28
25	TMS	40	30
24	TDI	39	29
23	SCI_TX1	29	23
22	SCI_TX0	14	10
21	SCI_RX1	30	24
20	SCI_RX0	13	9
19	TCAP	41	N/A
18	PWM1	32	N/A
17	PWM0	31	N/A
16	PMBUS_CLK	15	11

BIT	PIN_NAME	PIN NUMBER	
		UCD3138064-64 PIN	UCD3138064-48 PIN
15	PMBUS_DATA	16	12
14	PMBUS_CONTROL	28	22
13	PMBUS_ALERT	27	21
12	INT_EXT	34	N/A
11	FAULT2	42	31
10	FAULT1	36	26
9	FAULT0	35	25
8	SYNC	26	N/A
7	DPWM3B	24	20
6	DPWM3A	23	19
5	DPWM2B	22	18
4	DPWM2A	21	17
3	DPWM1B	20	16
2	DPWM1A	19	15
1	DPWM0B	18	14
0	DPWM0A	17	13

#### 4.22 Temperature Sensor Control

Temperature sensor control register provides internal temperature sensor enabling and trimming capabilities. The internal temperature sensor is disabled by default.

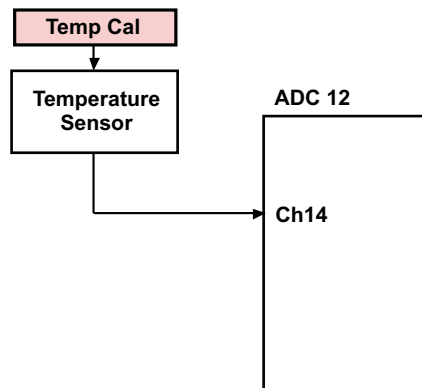

Figure 4-10. Internal Temp Sensor

Temperature sensor is calibrated at room temperature (25 °C) via a calibration register value.

The temperature sensor is measured using ADC12 (via Ch14). The temperature is then calculated using a mathematical formula involving the calibration register (this effectively adds a delta to the ADC measurement).

The temperature sensor can be enabled or disabled.

#### 4.23 I/O Mux Control

In different packages of UCD3138064 several I/O functions are multiplexed and routed toward a single physical pin. I/O Mux Control register may be used in order to choose a single specific functionality that is desired to be assigned to a physical device pin for your application.

## 4.24 Current Sharing Control

UCD3138064 provides three separate modes of current sharing operation.

- Analog bus current sharing
- PWM bus current sharing
- Master/Slave current sharing
- AD02 has a special ESD protection mechanism that prevents the pin from pulling down the current-share bus if power is missing from the UCD3138064

The simplified current sharing circuitry is shown in the drawing below:

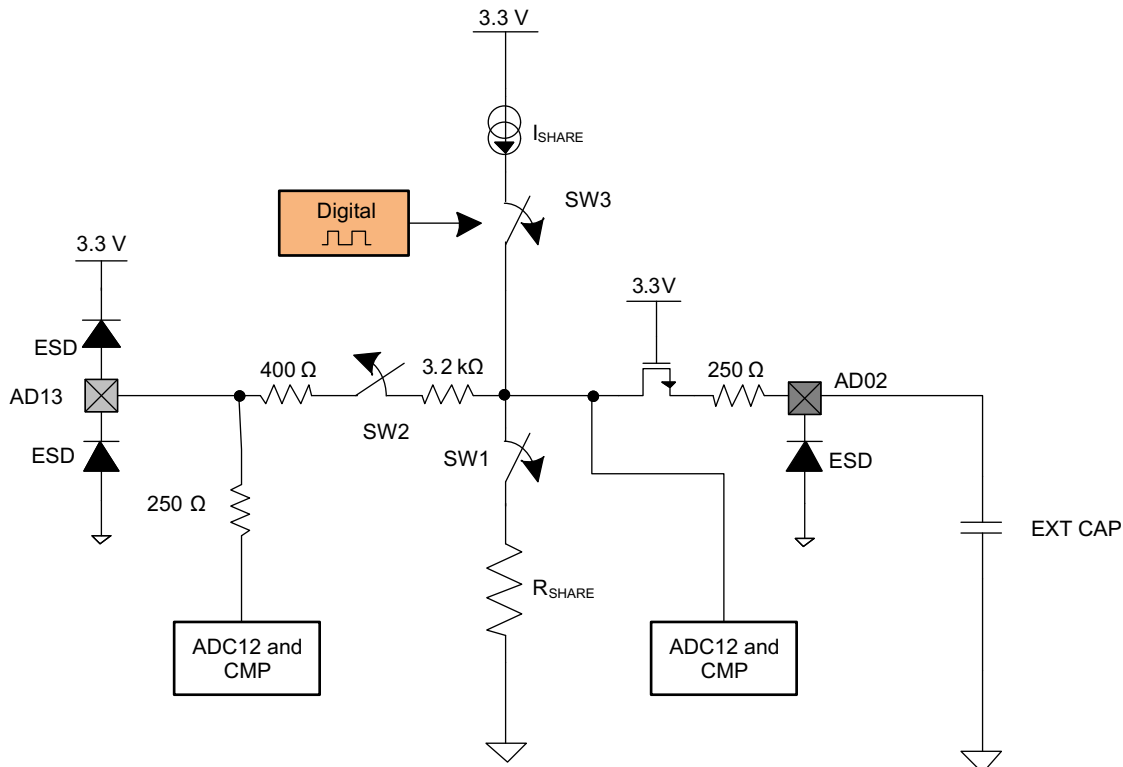

**Figure 4-11. Simplified Current Sharing Circuitry**

CURRENT SHARING MODE	FOR TEST ONLY, ALWAYS KEEP 00	CS_MODE	EN_SW1	EN_SW2	DPWM
Off or Slave Mode (3-state)	00	00 (default)	0	0	0
PWM Bus	00	01	1	0	ACTIVE
Off or Slave Mode (3-state)	00	10	0	0	0
Analog Bus or Master	00	11	0	1	0

The period and the duty of 8-bit PWM current source and the state of the SW1 and SW2 switches can be controlled through the current sharing control register (CSCTRL).

## 4.25 Temperature Reference

The temperature reference register (TEMPREF) provides the ADC12 count when ADC12 measures the internal temperature sensor (channel 14) during the factory trim and calibration.

This information can be used by different periodic temperature compensation routines implemented in the firmware. But it should not be overwritten by firmware, otherwise this factory written value will be lost.

## 5 IC Grounding and Layout Recommendations

- Two grounds are recommended: AGND (analog) and DGND (digital).
  - AGND plane should be on a different layer than DGND, and right under the UCD3138064 device.
  - UCD3138064 power pad should be tied to AGND plane by at least 4 vias
  - AGND plane should be just large enough to connect to all required components.
  - Power ground (PGND) can be independent or combined with DGND
  - The power pad of the driver IC should be tied to DGND
- Both 3.3VD and 3.3VA should have a local 4.7µF capacitor placed as close as possible to the device pins
- BPCAP decoupling **MUST** be connected as shown in the following figure. It is important that the ratio of the 2.2 µF to 1.0 µF capacitor be 2.2:1.

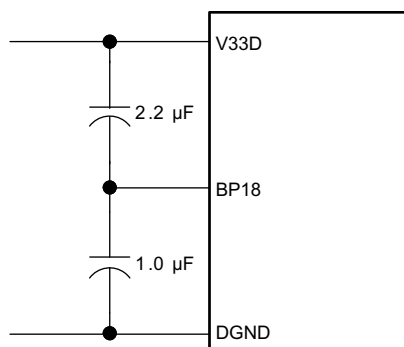

- All analog signal filter capacitors should be tied to AGND
  - If the gate driver device, such as UCD27524 or UCD27511/7 driver is used, the filter capacitor for the current sensing pin can be tied to DGND for easy layout
- All digital signals, such as GPIO, PMBus and PWM are referenced to DGND.
- The RESET pin capacitor (0.1µF) should be connected to either DGND or AGND locally. If the RESET pin is unused it is recommended to tie the pin directly to 3.3V.
- All filter and decoupling capacitors should be placed close to UCD3138064 as possible
  - Resistor placement is less critical and can be moved a little further away
- The DGND and AGND net-short resistor **MUST** be placed right between one UCD3138064's DGND pin and one AGND pin. Ground connections to the net short element should be made by a large via (or multiple paralleled vias) for each terminal of the net-short element.
- If a gate driver device such as UCC27524 or UCC27511/7 is on the control card and there is a PGND connection, a net-short resistor should be tied to the DGND plane and PGND plane by multiple vias. In addition the net-short element should be close to the driver IC.
- Configure all unused GPIO as inputs and connect them to ground.

## 6 Tools and Documentation

The application firmware for the UCD3138064 is developed on Texas Instruments Code Composer Studio (CCS) integrated development environment (v3.3 recommended).

Device programming, real time debug and monitoring/configuration of key device parameters for certain power topologies are all available through Texas Instruments' FUSION\_DIGITAL\_POWER\_DESIGNER Graphical User Interface ([http://www.ti.com/tool/fusion\\_digital\\_power\\_designer](http://www.ti.com/tool/fusion_digital_power_designer)). The FUSION\_DIGITAL\_POWER\_DESIGNER software application uses the PMBus protocol to communicate with the device over a serial bus using an interface adaptor known as the USB-TO-GPIO, available as an EVM from Texas Instruments (<http://www.ti.com/tool/usb-to-gpio>). PMBUS-based real-time debug capability is available through the 'Memory Debugger' tool within the Device GUI module of the FUSION\_DIGITAL\_POWER\_DESIGNER GUI, which represents a powerful alternative over traditional JTAG-based approaches'.

The software application can also be used to program the devices, with a version of the tool known as FUSION\_MFR\_GUI optimized for manufacturing environments ([http://www.ti.com/tool/fusion\\_mfr\\_gui](http://www.ti.com/tool/fusion_mfr_gui)). The FUSION\_MFR\_GUI tool supports multiple devices on a board, and includes built-in logging and reporting capabilities.

In terms of reference documentation, the following programmer's manuals are available offering detailed information regarding the application and usage of UCD3138064 digital controller:

1. UCD3138064 Programmer's Manual
2. UCD3138 Digital Power Peripheral Programmer's Manual Key topics covered in this manual include:
  - Digital Pulse Width Modulator (DPWM)
    - Modes of Operation (Normal/Multi/Phase-shift/Resonant etc)
    - Automatic Mode Switching
    - DPWMC, Edge Generation & Intra-Mux
  - Front End
    - Analog Front End
    - Error ADC or EADC
    - Front End DAC
    - Ramp Module
    - Successive Approximation Register Module
  - Filter
    - Filter Math
  - Loop Mux
    - Analog Peak Current Mode
    - Constant Current/Constant Power (CCCP)
    - Automatic Cycle Adjustment
  - Fault Mux
    - Analog Comparators
    - Digital Comparators
    - Fault Pin functions
    - DPWM Fault Action
    - Ideal Diode Emulation (IDE), DCM Detection
    - Oscillator Failure Detection
  - Register Map for all of the above peripherals in UCD3138064
3. UCD3138 Monitoring and Communications Programmer's Manual Key topics covered in this manual include:
  - ADC12
    - Control, Conversion, Sequencing & Averaging
    - Digital Comparators
    - Temperature Sensor
    - PMBUS Addressing

- Dual Sample & Hold
  - Miscellaneous Analog Controls (Current Sharing, Brown-Out, Clock-Gating)
  - PMBUS Interface
  - General Purpose Input Output (GPIO)
  - Timer Modules
  - PMBus
  - Register Map for all of the above peripherals in UCD3138064
4. UCD3138 ARM and Digital System Programmer's Manual  
Key topics covered in this manual include:
- Boot ROM & Boot Flash
    - BootROM Function
    - Memory Read/Write Functions
    - Checksum Functions
    - Flash Functions
    - Avoiding Program Flash Lock-Up
  - ARM7 Architecture
    - Modes of Operation
    - Hardware/Software Interrupts
    - Instruction Set
    - Dual State Inter-working (Thumb 16-bit Mode/ARM 32-bit Mode)
  - Memory & System Module
    - Address Decoder, DEC (Memory Mapping)
    - Memory Controller (MMC)
    - Central Interrupt Module
  - Register Map for all of the above peripherals in UCD3138064
5. FUSION\_DIGITAL\_POWER\_DESIGNER for UCD31XX Isolated Power Applications – User Guide

In addition to the tools and documentation described above, for the most up to date information regarding evaluation modules, reference application firmware and application notes/design tips, please visit <http://www.ti.com/product/ucd3138064>.

## 7 References

1. UCD3138064 Programmer's Manual (Literature Number: [SLUUAD8](#) )
2. UCD3138 Digital Power Peripherals Programmer's Manual (Literature Number:[SLUU995](#))
3. UCD3138 Monitoring & Communications Programmer's Manual (Literature Number:[SLUU996](#))
4. UCD3138 ARM and Digital System Programmer's Manual (Literature Number:[SLUU994](#))
5. FUSION\_DIGITAL\_POWER\_DESIGNER for Isolated Power Applications (Literature Number: [SLUA676](#))
6. Code Composer Studio Development Tools v3.3 – Getting Started Guide, (Literature Number: [SPRU509H](#))
7. ARM7TDMI-S Technical Reference Manual
8. System Management Bus (SMBus) Specification
9. PMBus™ Power System Management Protocol Specification <sup>(1)</sup>

(1) PMBus is a trademark of SMIF, Inc.



**PACKAGING INFORMATION**

Orderable Device	Status (1)	Package Type	Package Drawing	Pins	Package Qty	Eco Plan (2)	Lead/Ball Finish	MSL Peak Temp (3)	Op Temp (°C)	Top-Side Markings (4)	Samples
UCD3138064RGCR	ACTIVE	VQFN	RGC	64	2000	Green (RoHS & no Sb/Br)	CU NIPDAU	Level-3-260C-168 HR	-40 to 125	UCD3138064	<a href="#">Samples</a>
UCD3138064RGCT	ACTIVE	VQFN	RGC	64	250	Green (RoHS & no Sb/Br)	CU NIPDAU	Level-3-260C-168 HR	-40 to 125	UCD3138064	<a href="#">Samples</a>

(1) The marketing status values are defined as follows:

**ACTIVE:** Product device recommended for new designs.

**LIFEBUY:** TI has announced that the device will be discontinued, and a lifetime-buy period is in effect.

**NRND:** Not recommended for new designs. Device is in production to support existing customers, but TI does not recommend using this part in a new design.

**PREVIEW:** Device has been announced but is not in production. Samples may or may not be available.

**OBSOLETE:** TI has discontinued the production of the device.

(2) Eco Plan - The planned eco-friendly classification: Pb-Free (RoHS), Pb-Free (RoHS Exempt), or Green (RoHS & no Sb/Br) - please check <http://www.ti.com/productcontent> for the latest availability information and additional product content details.

**TBD:** The Pb-Free/Green conversion plan has not been defined.

**Pb-Free (RoHS):** TI's terms "Lead-Free" or "Pb-Free" mean semiconductor products that are compatible with the current RoHS requirements for all 6 substances, including the requirement that lead not exceed 0.1% by weight in homogeneous materials. Where designed to be soldered at high temperatures, TI Pb-Free products are suitable for use in specified lead-free processes.

**Pb-Free (RoHS Exempt):** This component has a RoHS exemption for either 1) lead-based flip-chip solder bumps used between the die and package, or 2) lead-based die adhesive used between the die and leadframe. The component is otherwise considered Pb-Free (RoHS compatible) as defined above.

**Green (RoHS & no Sb/Br):** TI defines "Green" to mean Pb-Free (RoHS compatible), and free of Bromine (Br) and Antimony (Sb) based flame retardants (Br or Sb do not exceed 0.1% by weight in homogeneous material)

(3) MSL, Peak Temp. -- The Moisture Sensitivity Level rating according to the JEDEC industry standard classifications, and peak solder temperature.

(4) Multiple Top-Side Markings will be inside parentheses. Only one Top-Side Marking contained in parentheses and separated by a "~" will appear on a device. If a line is indented then it is a continuation of the previous line and the two combined represent the entire Top-Side Marking for that device.

**Important Information and Disclaimer:** The information provided on this page represents TI's knowledge and belief as of the date that it is provided. TI bases its knowledge and belief on information provided by third parties, and makes no representation or warranty as to the accuracy of such information. Efforts are underway to better integrate information from third parties. TI has taken and continues to take reasonable steps to provide representative and accurate information but may not have conducted destructive testing or chemical analysis on incoming materials and chemicals. TI and TI suppliers consider certain information to be proprietary, and thus CAS numbers and other limited information may not be available for release.

In no event shall TI's liability arising out of such information exceed the total purchase price of the TI part(s) at issue in this document sold by TI to Customer on an annual basis.

## TAPE AND REEL INFORMATION



### QUADRANT ASSIGNMENTS FOR PIN 1 ORIENTATION IN TAPE



\*All dimensions are nominal

Device	Package Type	Package Drawing	Pins	SPQ	Reel Diameter (mm)	Reel Width W1 (mm)	A0 (mm)	B0 (mm)	K0 (mm)	P1 (mm)	W (mm)	Pin1 Quadrant
UCD3138064RGCR	VQFN	RGC	64	2000	330.0	16.4	9.3	9.3	1.5	12.0	16.0	Q2
UCD3138064RGCT	VQFN	RGC	64	250	180.0	16.4	9.3	9.3	1.5	12.0	16.0	Q2

**TAPE AND REEL BOX DIMENSIONS**

\*All dimensions are nominal

Device	Package Type	Package Drawing	Pins	SPQ	Length (mm)	Width (mm)	Height (mm)
UCD3138064RGCR	VQFN	RGC	64	2000	367.0	367.0	38.0
UCD3138064RGCT	VQFN	RGC	64	250	210.0	185.0	35.0

# MECHANICAL DATA

RGC(S-PVQFN-N64) CUSTOM DEVICE PLASTIC QUAD FLATPACK NO-LEAD

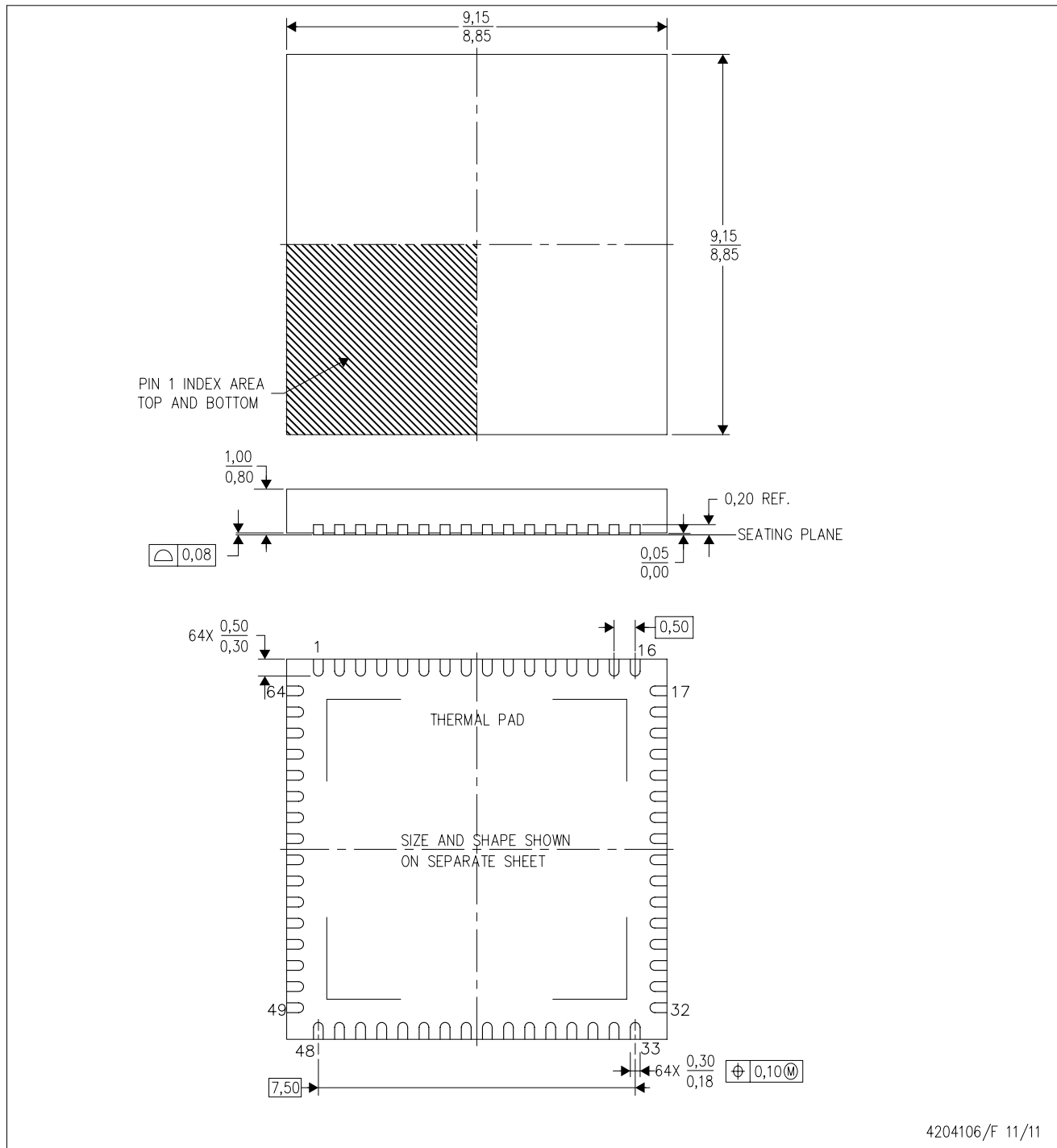

- NOTES:
- A. All linear dimensions are in millimeters. Dimensioning and tolerancing per ASME Y14.5-1994.
  - B. This drawing is subject to change without notice.
  - C. Quad Flatpack, No-leads (QFN) package configuration.
  - D. The package thermal pad must be soldered to the board for thermal and mechanical performance.
  - E. See the additional figure in the Product Data Sheet for details regarding the exposed thermal pad features and dimensions.

# THERMAL PAD MECHANICAL DATA

RGC (S-PVQFN-N64)

PLASTIC QUAD FLATPACK NO-LEAD

## THERMAL INFORMATION

This package incorporates an exposed thermal pad that is designed to be attached directly to an external heatsink. The thermal pad must be soldered directly to the printed circuit board (PCB). After soldering, the PCB can be used as a heatsink. In addition, through the use of thermal vias, the thermal pad can be attached directly to the appropriate copper plane shown in the electrical schematic for the device, or alternatively, can be attached to a special heatsink structure designed into the PCB. This design optimizes the heat transfer from the integrated circuit (IC).

For information on the Quad Flatpack No-Lead (QFN) package and its advantages, refer to Application Report, QFN/SON PCB Attachment, Texas Instruments Literature No. SLUA271. This document is available at [www.ti.com](http://www.ti.com).

The exposed thermal pad dimensions for this package are shown in the following illustration.

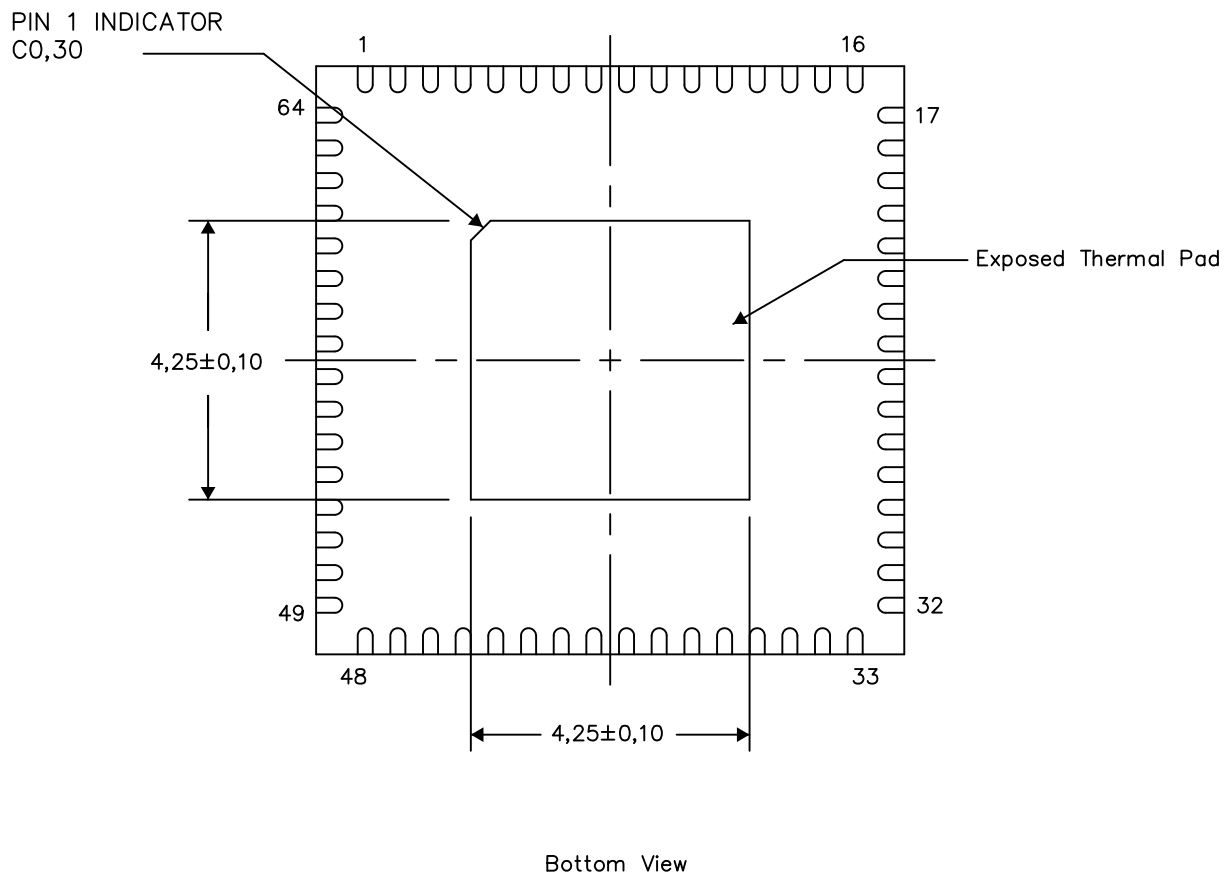

Exposed Thermal Pad Dimensions

4206192-3/X 03/13

NOTE: A. All linear dimensions are in millimeters

RGC (S-PVQFN-N64)

PLASTIC QUAD FLATPACK NO-LEAD

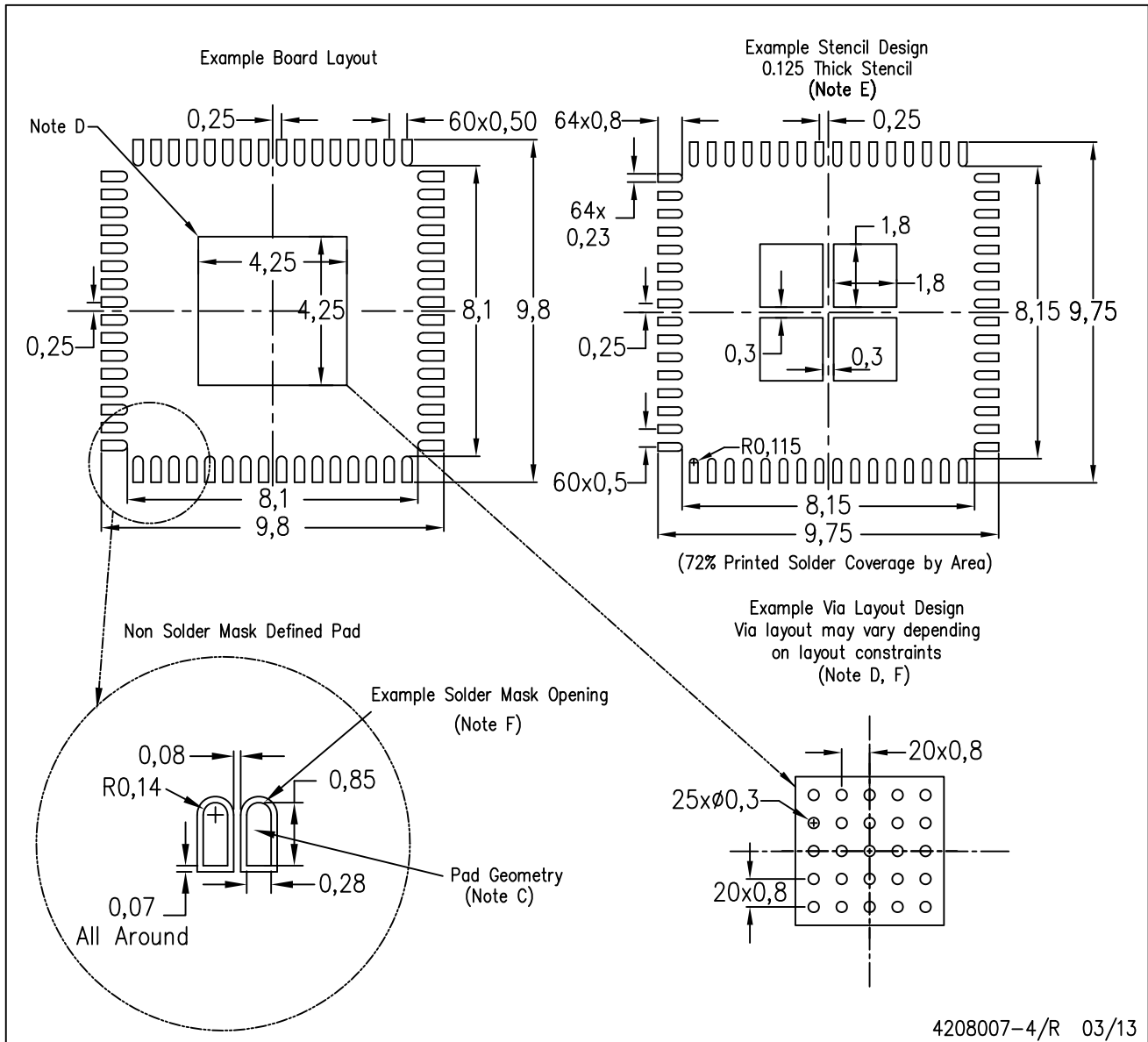

4208007-4/R 03/13

- NOTES:
- A. All linear dimensions are in millimeters.
  - B. This drawing is subject to change without notice.
  - C. Publication IPC-7351 is recommended for alternate designs.
  - D. This package is designed to be soldered to a thermal pad on the board. Refer to Application Note, Quad Flat-Pack Packages, Texas Instruments Literature No. SLUA271, and also the Product Data Sheets for specific thermal information, via requirements, and recommended board layout. These documents are available at [www.ti.com](http://www.ti.com) <<http://www.ti.com>>.
  - E. Laser cutting apertures with trapezoidal walls and also rounding corners will offer better paste release. Customers should contact their board assembly site for stencil design recommendations. Refer to IPC 7525 for stencil design considerations.
  - F. Customers should contact their board fabrication site for recommended solder mask tolerances and via tenting recommendations for vias placed in thermal pad.

## IMPORTANT NOTICE

Texas Instruments Incorporated and its subsidiaries (TI) reserve the right to make corrections, enhancements, improvements and other changes to its semiconductor products and services per JESD46, latest issue, and to discontinue any product or service per JESD48, latest issue. Buyers should obtain the latest relevant information before placing orders and should verify that such information is current and complete. All semiconductor products (also referred to herein as "components") are sold subject to TI's terms and conditions of sale supplied at the time of order acknowledgment.

TI warrants performance of its components to the specifications applicable at the time of sale, in accordance with the warranty in TI's terms and conditions of sale of semiconductor products. Testing and other quality control techniques are used to the extent TI deems necessary to support this warranty. Except where mandated by applicable law, testing of all parameters of each component is not necessarily performed.

TI assumes no liability for applications assistance or the design of Buyers' products. Buyers are responsible for their products and applications using TI components. To minimize the risks associated with Buyers' products and applications, Buyers should provide adequate design and operating safeguards.

TI does not warrant or represent that any license, either express or implied, is granted under any patent right, copyright, mask work right, or other intellectual property right relating to any combination, machine, or process in which TI components or services are used. Information published by TI regarding third-party products or services does not constitute a license to use such products or services or a warranty or endorsement thereof. Use of such information may require a license from a third party under the patents or other intellectual property of the third party, or a license from TI under the patents or other intellectual property of TI.

Reproduction of significant portions of TI information in TI data books or data sheets is permissible only if reproduction is without alteration and is accompanied by all associated warranties, conditions, limitations, and notices. TI is not responsible or liable for such altered documentation. Information of third parties may be subject to additional restrictions.

Resale of TI components or services with statements different from or beyond the parameters stated by TI for that component or service voids all express and any implied warranties for the associated TI component or service and is an unfair and deceptive business practice. TI is not responsible or liable for any such statements.

Buyer acknowledges and agrees that it is solely responsible for compliance with all legal, regulatory and safety-related requirements concerning its products, and any use of TI components in its applications, notwithstanding any applications-related information or support that may be provided by TI. Buyer represents and agrees that it has all the necessary expertise to create and implement safeguards which anticipate dangerous consequences of failures, monitor failures and their consequences, lessen the likelihood of failures that might cause harm and take appropriate remedial actions. Buyer will fully indemnify TI and its representatives against any damages arising out of the use of any TI components in safety-critical applications.

In some cases, TI components may be promoted specifically to facilitate safety-related applications. With such components, TI's goal is to help enable customers to design and create their own end-product solutions that meet applicable functional safety standards and requirements. Nonetheless, such components are subject to these terms.

No TI components are authorized for use in FDA Class III (or similar life-critical medical equipment) unless authorized officers of the parties have executed a special agreement specifically governing such use.

Only those TI components which TI has specifically designated as military grade or "enhanced plastic" are designed and intended for use in military/aerospace applications or environments. Buyer acknowledges and agrees that any military or aerospace use of TI components which have **not** been so designated is solely at the Buyer's risk, and that Buyer is solely responsible for compliance with all legal and regulatory requirements in connection with such use.

TI has specifically designated certain components as meeting ISO/TS16949 requirements, mainly for automotive use. In any case of use of non-designated products, TI will not be responsible for any failure to meet ISO/TS16949.

### Products

Audio	<a href="http://www.ti.com/audio">www.ti.com/audio</a>
Amplifiers	<a href="http://amplifier.ti.com">amplifier.ti.com</a>
Data Converters	<a href="http://dataconverter.ti.com">dataconverter.ti.com</a>
DLP® Products	<a href="http://www.dlp.com">www.dlp.com</a>
DSP	<a href="http://dsp.ti.com">dsp.ti.com</a>
Clocks and Timers	<a href="http://www.ti.com/clocks">www.ti.com/clocks</a>
Interface	<a href="http://interface.ti.com">interface.ti.com</a>
Logic	<a href="http://logic.ti.com">logic.ti.com</a>
Power Mgmt	<a href="http://power.ti.com">power.ti.com</a>
Microcontrollers	<a href="http://microcontroller.ti.com">microcontroller.ti.com</a>
RFID	<a href="http://www.ti-rfid.com">www.ti-rfid.com</a>
OMAP Applications Processors	<a href="http://www.ti.com/omap">www.ti.com/omap</a>
Wireless Connectivity	<a href="http://www.ti.com/wirelessconnectivity">www.ti.com/wirelessconnectivity</a>

### Applications

Automotive and Transportation	<a href="http://www.ti.com/automotive">www.ti.com/automotive</a>
Communications and Telecom	<a href="http://www.ti.com/communications">www.ti.com/communications</a>
Computers and Peripherals	<a href="http://www.ti.com/computers">www.ti.com/computers</a>
Consumer Electronics	<a href="http://www.ti.com/consumer-apps">www.ti.com/consumer-apps</a>
Energy and Lighting	<a href="http://www.ti.com/energy">www.ti.com/energy</a>
Industrial	<a href="http://www.ti.com/industrial">www.ti.com/industrial</a>
Medical	<a href="http://www.ti.com/medical">www.ti.com/medical</a>
Security	<a href="http://www.ti.com/security">www.ti.com/security</a>
Space, Avionics and Defense	<a href="http://www.ti.com/space-avionics-defense">www.ti.com/space-avionics-defense</a>
Video and Imaging	<a href="http://www.ti.com/video">www.ti.com/video</a>

### TI E2E Community

[e2e.ti.com](http://e2e.ti.com)