

USB Dedicated Charging Port Controller and Current Limiting Power Switch

Check for Samples: [TPS2511-Q1](#)

FEATURES

- Qualified for Automotive Application
- AEC-Q100 Qualified with the Following Results:
 - Device Temperature Grade 1: -40°C to 125°C Ambient Operating Temperature Range
 - Device HMB ESD Classification Level H2
 - Device CDM ESD Classification Level C5
- Supports a DCP Shorting D+ to D-
- Supports a DCP Applying 2.0 V on D+ and 2.7 V on D- (or 2.7 V on D+ and 2.0 V on D-)
- Supports a DCP Applying 1.2 V on Data Lines
- Automatically Switch D+ and D- Lines Connections for an Attached Device
- Hiccup Mode for Short-Circuit Protection
- Provides \overline{CS} Pin for USB Cable Compensation
- Programmable Current Limit (ILIM_SET Pin)
- 80-mΩ typical High-Side MOSFET
- Accurate $\pm 10\%$ Current-Limit at 2.3 A typical
- Meets USB Power Switch Requirements
- Drop-In and List of materials Compatible with TPS2511
- Operating Range: 4.5 V to 5.5 V
- Available in MSOP, 8-Pin Package
- UL Listed and CB File Number E169910

APPLICATIONS

- Vehicle USB Power Charger
- AC-DC Wall Adapter with USB Port
- Other USB Charger
- Automotive Infotainment Systems

DESCRIPTION

The TPS2511-Q1 is a USB dedicated charging port (DCP) controller and current limiting power switch. An auto-detect feature monitors USB data line voltage, and automatically provides the correct electrical signatures on the data lines to charge compliant devices among the following charging schemes:

- Divider DCP, required to apply 2.7 V on D+ and 2.0 V on D- or 2.0 V on D+ and 2.7 V on D-;
- BC1.2 DCP, required to short D+ to D-;
- 1.2 V on both D+ and D-.

The TPS2511-Q1 is a 80-mΩ power-distribution switch intended for applications where heavy capacitive loads and short-circuits are likely to be encountered. This device also provides hiccup mode when the output (OUT) voltage is less than 3.80 V typical or when an over-temperature protection occurs during an overload condition. Accurate and programmable current limit provides flexibility and convenience for applications. The TPS2511-Q1 provides a \overline{CS} pin for USB cable resistance compensation and a EN pin to turn on and turn off the device.

SIMPLIFIED APPLICATION

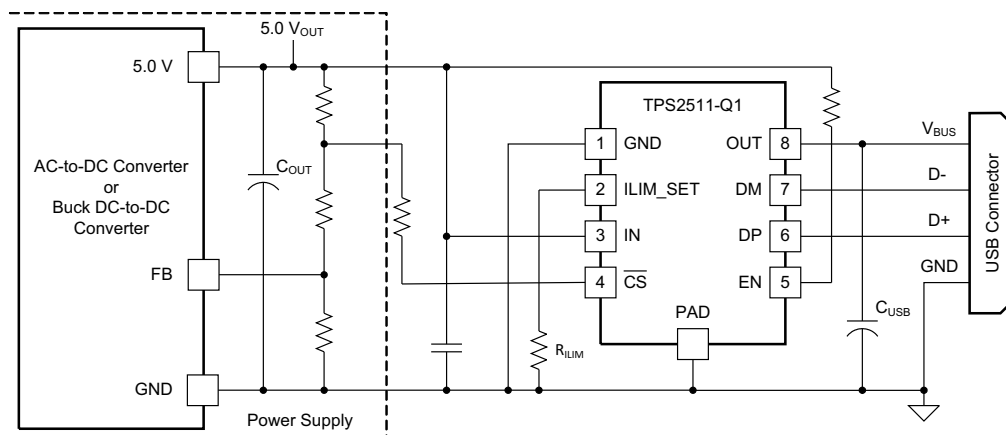

UDG-13098



Please be aware that an important notice concerning availability, standard warranty, and use in critical applications of Texas Instruments semiconductor products and disclaimers thereto appears at the end of this data sheet.

TPS2511-Q1

SLUSBK5 – JUNE 2013

www.ti.com



This integrated circuit can be damaged by ESD. Texas Instruments recommends that all integrated circuits be handled with appropriate precautions. Failure to observe proper handling and installation procedures can cause damage.

ESD damage can range from subtle performance degradation to complete device failure. Precision integrated circuits may be more susceptible to damage because very small parametric changes could cause the device not to meet its published specifications.

ORDERING INFORMATION⁽¹⁾

T _A	PACKAGE	PINS	TRANSPORT MEDIA	MINIMUM QUANTITY	ORDERABLE DEVICE NUMBER	TOP-SIDE MARKING
-40°C to 85°C	MSOP (DGN)	8	Tube	80	TPS2511QDGNQ1	2511Q
			Tape and Reel	2500	TPS2511QDGNRQ1	2511Q

(1) For the most current package and ordering information, see the Package Option Addendum at the end of this document, or see the TI web site at www.ti.com.

ABSOLUTE MAXIMUM RATINGS

Over recommended junction temperature range, voltages are referenced to GND (unless otherwise noted)

		MIN	MAX	UNIT
Supply voltage range	IN	-0.3	7	V
Input voltage range	EN, ILIM_SET	-0.3	7	
Voltage range	OUT, \overline{CS}	-0.3	7	
	IN to OUT	-7	7	
	DP output voltage, DM output voltage	-0.3	IN+0.3 or 5.7	
	DP input voltage, DM input voltage	-0.3	IN+0.3 or 5.7	
Continuous output sink current	DP input current, DM input current		35	mA
Continuous output source current	DP output current, DM output current		35	
Continuous output sink current	\overline{CS}		10	
Continuous output source current	ILIM_SET		Internally limited	
ESD rating	Human Body Model (HBM)	IN, OUT, EN, ILIM_SET, \overline{CS}	2	kV
		DP, DM	7.5	
	Charging Device Model (CDM)		500	V
Operating junction temperature, T _J			Internally limited	
Storage temperature range, T _{stg}		-65	150	°C

THERMAL INFORMATION

THERMAL METRIC ⁽¹⁾		TPS2511-Q1	UNITS
		DGN (8 PINS)	
θ_{JA}	Junction-to-ambient thermal resistance	65.2	°C/W
θ_{JCTop}	Junction-to-case (top) thermal resistance	53.3	
θ_{JB}	Junction-to-board thermal resistance	36.9	
Ψ_{JT}	Junction-to-top characterization parameter	3.9	
Ψ_{JB}	Junction-to-board characterization parameter	36.6	
θ_{JCbott}	Junction-to-case (bottom) thermal resistance	13.4	

(1) For more information about traditional and new thermal metrics, see the *IC Package Thermal Metrics* application report, SPRA953.

RECOMMENDED OPERATING CONDITIONS

voltages are referenced to GND (unless otherwise noted), positive current are into pins.

		MIN	MAX	UNIT
V_{IN}	Input voltage of IN	4.5	5.5	V
$V_{\overline{CS}}$	Input voltage of \overline{CS}	0	5.5	
V_{EN}	Input voltage of EN	0	5.5	
V_{DP}	DP data line input voltage	0	5.5	
V_{DM}	DM data line input voltage	0	5.5	
I_{DP}	Continuous sink/source current		±10	mA
I_{DM}	Continuous sink/source current		±10	
$I_{\overline{CS}}$	Continuous sink current		2	
I_{OUT}	Continuous output current of OUT		2.2	A
R_{ILIM_SET}	A resistor of current-limit, ILIM_SET to GND	16.9	750	kΩ
T_J	Operating junction temperature	-40	125	°C

ELECTRICAL CHARACTERISTICS

Conditions are $-40^{\circ}\text{C} \leq (T_J = T_A) \leq 125^{\circ}\text{C}$, $4.5\text{ V} \leq V_{IN} \leq 5.5\text{ V}$, $V_{EN} = V_{IN}$ and $R_{ILIM_SET} = 22.1\text{ k}\Omega$. Positive current are into pins. Typical values are at 25°C . All voltages are with respect to GND (unless otherwise noted).

PARAMETER		TEST CONDITIONS	MIN	TYP	MAX	UNIT
POWER SWITCH						
$R_{DS(on)}$	Static drain-source on-state resistance	$I_{OUT} = 2\text{ A}$		80	125	mΩ
		$I_{OUT} = 2\text{ A}$, $-40^{\circ}\text{C} \leq (T_J = T_A) \leq 85^{\circ}\text{C}$		80	110	
		$I_{OUT} = 2\text{ A}$, $T_J = T_A = 25^{\circ}\text{C}$		80	89	
t_r	OUT voltage rise time	$C_L = 1\text{ }\mu\text{F}$, $R_L = 100\text{ }\Omega$, $V_{IN} = 5\text{ V}$ see Figure 1 , Figure 3		1.0	1.5	ms
t_f	OUT voltage fall time	$C_L = 1\text{ }\mu\text{F}$, $R_L = 100\text{ }\Omega$, $V_{IN} = 5\text{ V}$ see Figure 1 , Figure 3	0.2	0.35	0.5	
I_{REV}	Reverse leakage current	$V_{OUT} = 5.5\text{ V}$, $V_{IN} = V_{EN} = 0\text{ V}$		0.01	2	μA
DISCHARGE						
R_{DCHG}	Discharge resistance	$V_{OUT} = 4\text{ V}$	400	500	630	Ω
CURRENT LIMIT						
I_{OS}	OUT short-circuit current limit	$R_{ILIM_SET} = 44.2\text{ k}\Omega$	1060	1160	1270	mA
		$R_{ILIM_SET} = 22.1\text{ k}\Omega$	2110	2300	2550	
		$R_{ILIM_SET} = 16.9\text{ k}\Omega$	2760	3025	3330	
t_{IOS}	Short-circuit response time ⁽¹⁾	$V_{IN} = 5.0\text{ V}$, $R_L = 50\text{ m}\Omega$, 2 inches lead length, See Figure 4		1.5		μs
HICCUP MODE						
V_{OUT_SHORT}	OUT voltage threshold of going into hiccup mode	$V_{IN} = 5.0\text{ V}$, $R_{ILIM_SET} = 210\text{ k}\Omega$	3.6	3.8	4.1	V
t_{OS_DEG}	On time of hiccup mode ⁽¹⁾	$V_{IN} = 5.0\text{ V}$, $R_L = 0$		16		ms
$t_{SC_TURN_OFF}$	Off time of hiccup mode ⁽¹⁾	$V_{IN} = 5.0\text{ V}$, $R_L = 0$		12		s
UNDERVOLTAGE LOCKOUT						
V_{UVLO}	IN UVLO threshold voltage, rising		3.9	4.1	4.3	V
	Hysteresis ⁽¹⁾			100		mV
SUPPLY CURRENT						
I_{IN_OFF}	Disabled, IN supply current	$V_{EN} = 0\text{ V}$, $V_{IN} = 5.5\text{ V}$, $-40^{\circ}\text{C} \leq T_J \leq 85^{\circ}\text{C}$		0.1	5	μA
I_{IN_ON}	Enabled, IN supply current	$V_{EN} = V_{IN}$, $R_{ILIM_SET} = 210\text{ k}\Omega$		180	230	

(1) Specified by design. Not production tested.

ELECTRICAL CHARACTERISTICS (continued)

Conditions are $-40^{\circ}\text{C} \leq (T_J = T_A) \leq 125^{\circ}\text{C}$, $4.5\text{ V} \leq V_{\text{IN}} \leq 5.5\text{ V}$, $V_{\text{EN}} = V_{\text{IN}}$ and $R_{\text{ILIM_SET}} = 22.1\text{ k}\Omega$. Positive current are into pins. Typical values are at 25°C . All voltages are with respect to GND (unless otherwise noted).

PARAMETER		TEST CONDITIONS	MIN	TYP	MAX	UNIT
THERMAL SHUTDOWN						
Temperature rising threshold ⁽²⁾		Not in current limit	155			°C
		In current limit	135			
Hysteresis ⁽²⁾			10			
OUT CURRENT DETECTION						
$I_{\text{HCC_TH}}$	Load detection current threshold, rising ⁽²⁾	$R_{\text{ILIM_SET}} = 22.1\text{ k}\Omega$	1060			mA
		$R_{\text{ILIM_SET}} = 44.2\text{ k}\Omega$	560			
$I_{\text{HCC_TH_HYS}}$	Load detection current Hysteresis ⁽²⁾	$R_{\text{ILIM_SET}} = 22.1\text{ k}\Omega$	230			mA
		$R_{\text{ILIM_SET}} = 44.2\text{ k}\Omega$	120			
$V_{\overline{\text{CS}}}$	$\overline{\text{CS}}$ output active low voltage ⁽²⁾	$I_{\overline{\text{CS}}} = 1\text{ mA}$	0	80	140	mV
$t_{\text{CS_EN}}$	$\overline{\text{CS}}$ deglitch time during turning on ⁽²⁾	$I_{\overline{\text{CS}}} = 1\text{ mA}$	8			ms
ENABLE INPUT (EN)						
$V_{\text{EN_TRIP}}$	EN threshold voltage, falling		0.9	1.1	1.65	V
$V_{\text{EN_TRIP_HYS}}$	Hysteresis		100	200	300	mV
I_{EN}	Leakage current	$V_{\text{EN}} = 0\text{ V}$ or $V_{\text{EN}} = 5.5\text{ V}$	-0.5		0.5	μA
t_{on}	OUT voltage turn-on time	$C_L = 1\text{ }\mu\text{F}$, $R_L = 100\text{ }\Omega$, see Figure 1 , Figure 2	2.6		5	ms
t_{off}	OUT voltage turn-off time		1.7		3	
BC 1.2 DCP MODE (SHORT MODE)						
$R_{\text{DPM_SHORT}}$	DP and DM shorting resistance	$V_{\text{DP}} = 0.8\text{ V}$, $I_{\text{DM}} = 1\text{ mA}$	125		200	Ω
$R_{\text{DCHG_SHORT}}$	Resistance between DP/DM and GND	$V_{\text{DP}} = 0.8\text{ V}$	400	700	1300	k Ω
$V_{\text{DPL_TH_DETACH}}$	Voltage threshold on DP under which the device goes back to divider mode		310	330	350	mV
$V_{\text{DPL_TH_DETACH_HYS}}$	Hysteresis		50 ⁽²⁾			mV
DIVIDER MODE						
$V_{\text{DP_2.7V}}$	DP output voltage	$V_{\text{IN}} = 5.0\text{ V}$	2.57	2.7	2.84	V
$V_{\text{DM_2.0V}}$	DM output voltage	$V_{\text{IN}} = 5.0\text{ V}$	1.9	2.0	2.1	
$R_{\text{DP_PAD1}}$	DP output impedance	$I_{\text{DP}} = -5\text{ }\mu\text{A}$	24	30	40	k Ω
$R_{\text{DM_PAD1}}$	DM output impedance	$I_{\text{DM}} = -5\text{ }\mu\text{A}$	24	30	40	
1.2 V / 1.2 V MODE						
$V_{\text{DP_1.2V}}$	DP output voltage	$V_{\text{IN}} = 5.0\text{ V}$	1.12	1.2	1.28	V
$V_{\text{DM_1.2V}}$	DM output voltage	$V_{\text{IN}} = 5.0\text{ V}$	1.12	1.2	1.28	V
$R_{\text{DP_PAD2}}$	DP output impedance	$I_{\text{DP}} = -5\text{ }\mu\text{A}$	80	105	130	k Ω
$R_{\text{DM_PAD2}}$	DM output impedance	$I_{\text{DM}} = -5\text{ }\mu\text{A}$	80	105	130	k Ω

(2) Specified by design. Not production tested.

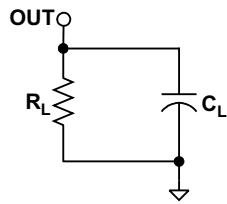

Figure 1. Output Rise and Fall Test Load

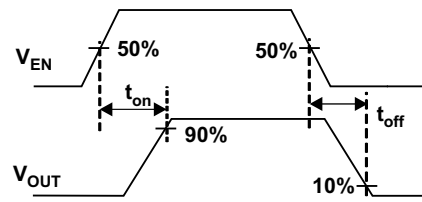

Figure 2. Enable Timing, Active High Enable

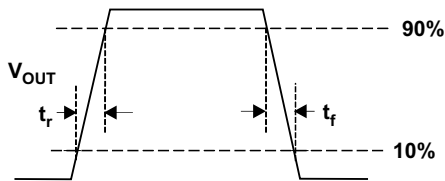

Figure 3. Power-On and Off

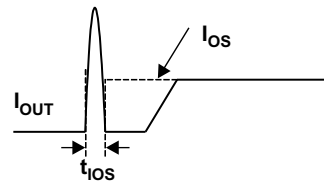
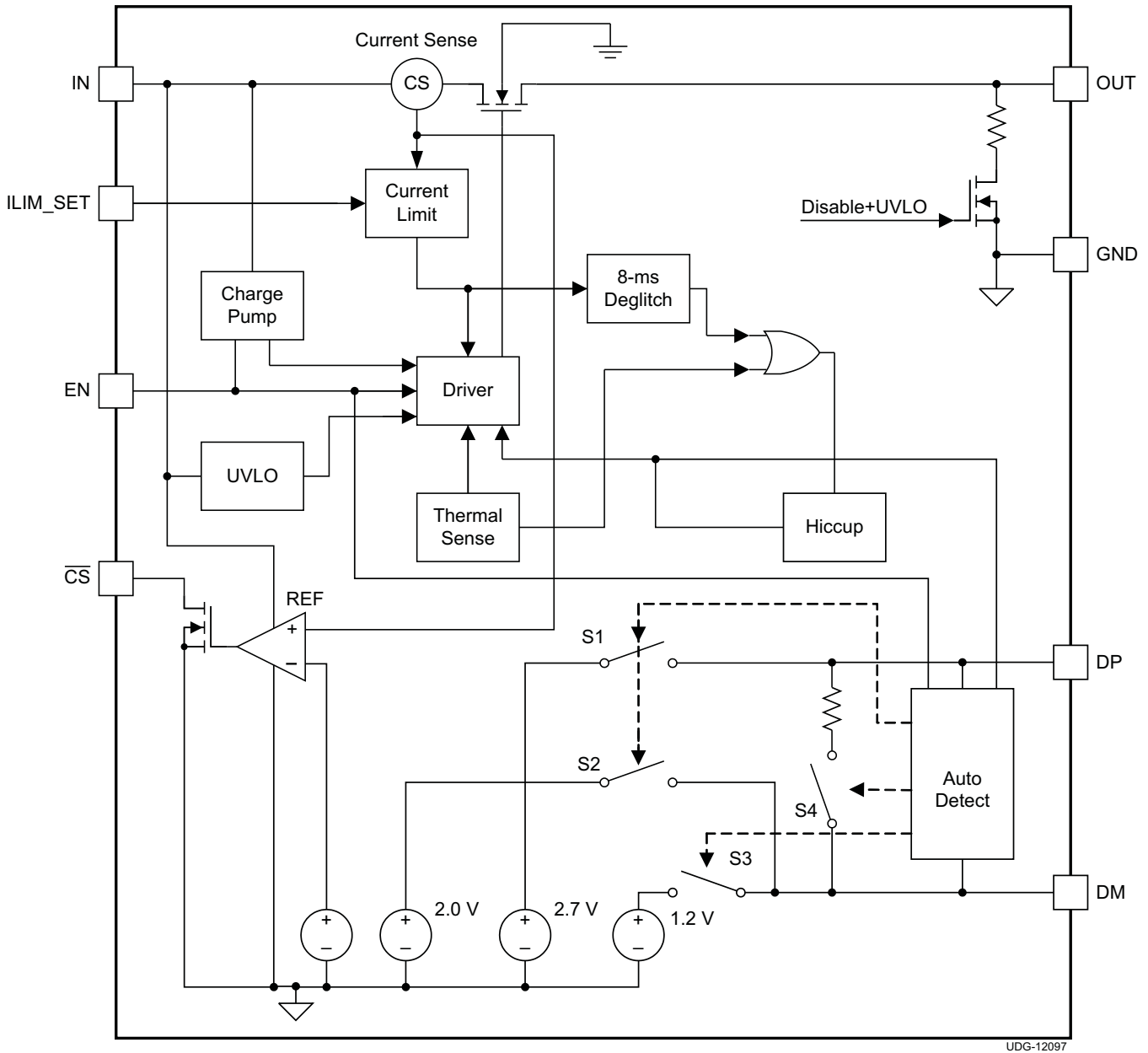

Figure 4. Output Short-Circuit Parameters

FUNCTIONAL BLOCK DIAGRAM



PRODUCT PREVIEW

DEVICE INFORMATION

DGN PACKAGE (MSOP)
8 PINS
(Top View)

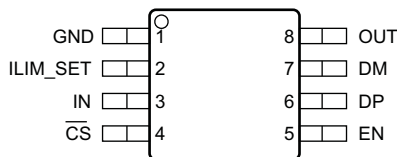

PIN FUNCTIONS

PIN		TYPE ⁽¹⁾	DESCRIPTION
NAME	NO.		
\overline{CS}	4	O	Active low open -drain output, when OUT current is more than approximately half of the current limit set by a resistor on ILIM_SET pin, the output is active low. Maximum sink current is 10 mA.
DM	7	I/O	Connected to the D- or D+ line of USB connector, provide the correct voltage with an attached portable equipment for DCP detection, high impedance while disabled.
DP	6	I/O	Connected to the D+ or D- line of USB connector, provide the correct voltage with an attached portable equipment for DCP detection, high impedance while disabled.
EN	5	I	Logic-level control input, when it is high, turns power switch on, when it is low, turns power switch off and turns DP and DM into the high impedance state.
GND	1	G	Ground connection.
ILIM_SET	2	I	External resistor used to set current-limiting threshold, recommended $16.9\text{ k}\Omega \leq R_{ILIM_SET} \leq 750\text{ k}\Omega$.
IN	3	P	Power supply. Input voltage connected to power switch, connect a ceramic capacitor with a value of 0.1- μF or greater from the IN pin to GND as close to the device as possible.
OUT	8	O	Power-switch output. Connect to VBUS of USB
PowerPAD		G	Ground connection.

(1) G = Ground, I = Input, O = Output, P = Power

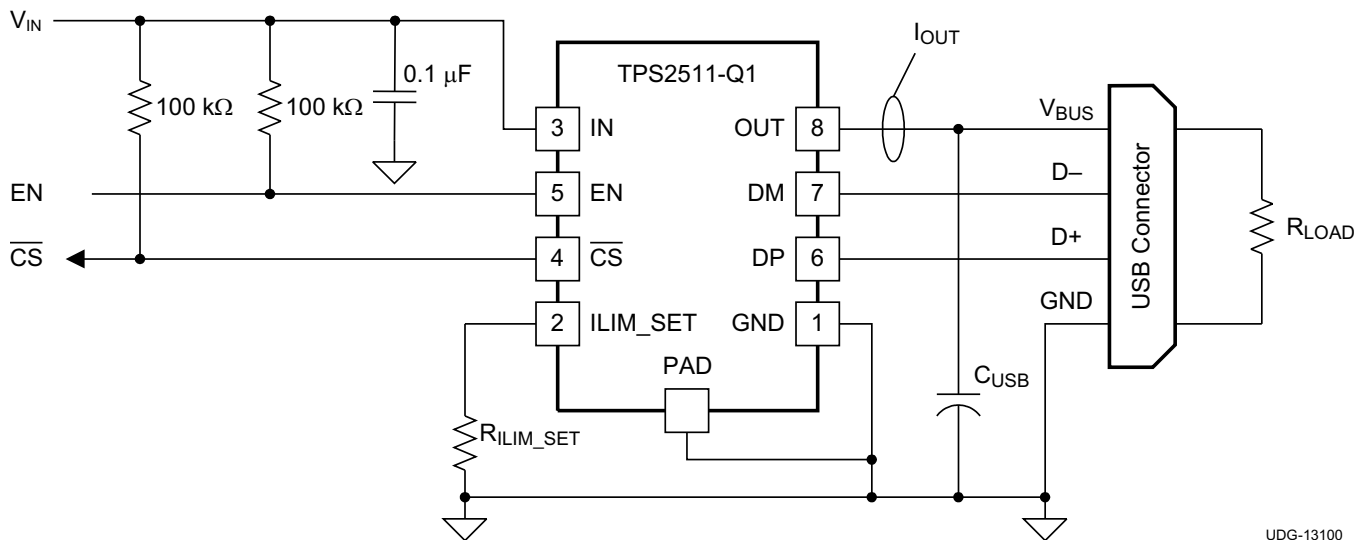

Figure 5. Test Circuit for System Operation in Typical Characteristics Section

PRODUCT PREVIEW

TYPICAL CHARACTERISTICS

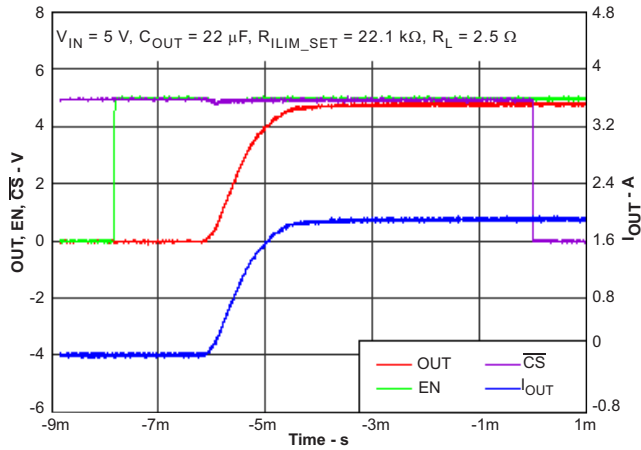

Figure 6. Turn on Delay and Rise Time With 22-µF Load

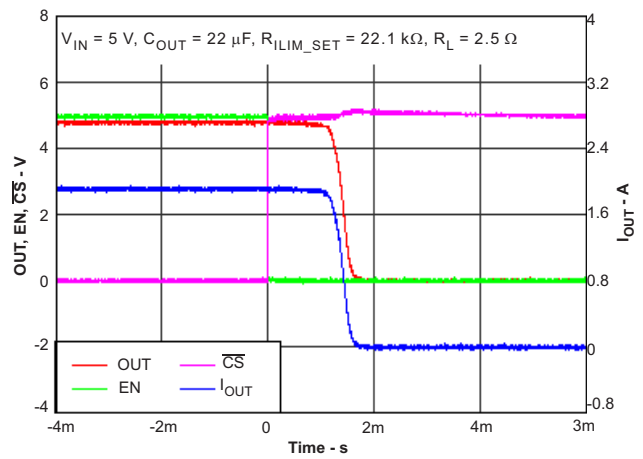

Figure 7. Turn off Delay and Fall Time With 22-µF Load

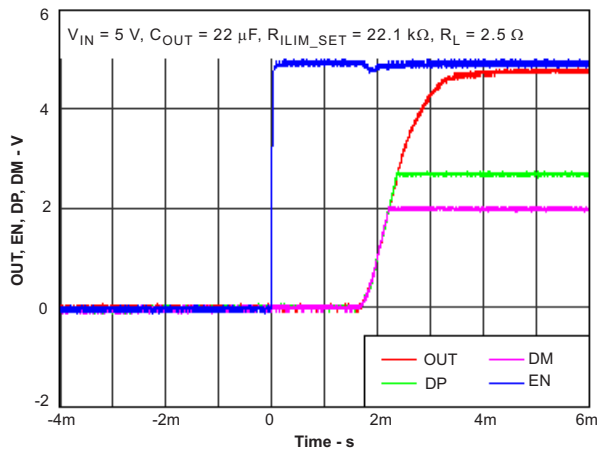

Figure 8. Enable into 2.5-Ω Load

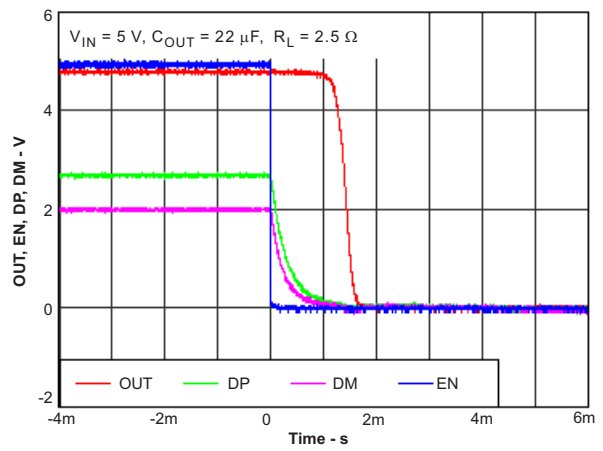

Figure 9. Disable with 2.5-Ω Load

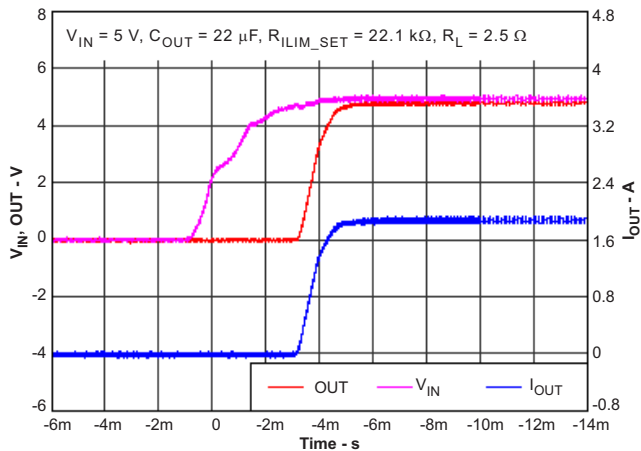

Figure 10. Power Up – Enabled

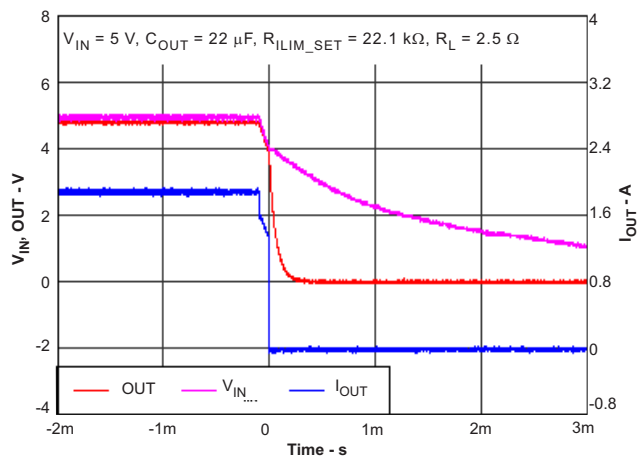

Figure 11. Power Down – Enabled

PRODUCT PREVIEW

TYPICAL CHARACTERISTICS (continued)

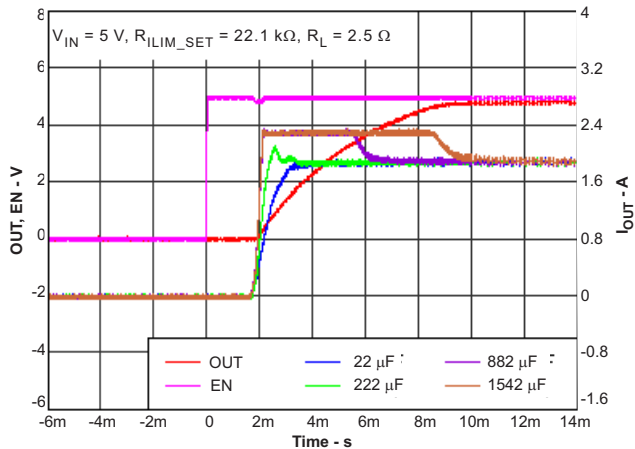

Figure 12. Inrush Current with Different Capacitance Load

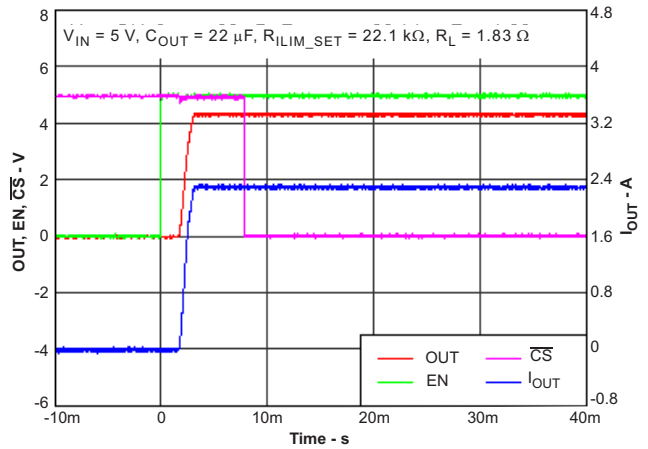

Figure 13. Enable into 1.83-Ω Load

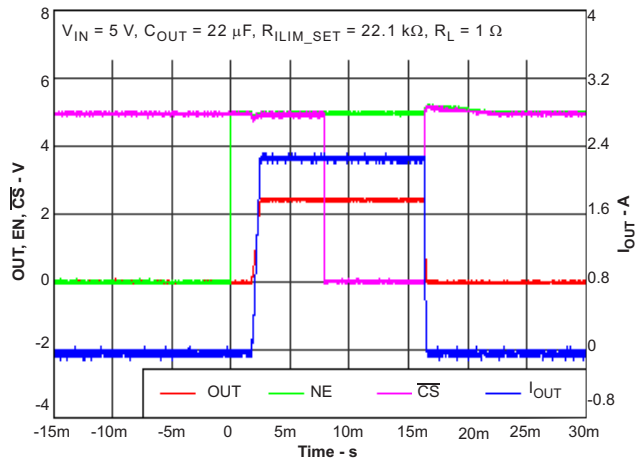

Figure 14. Enable into 1-Ω Load

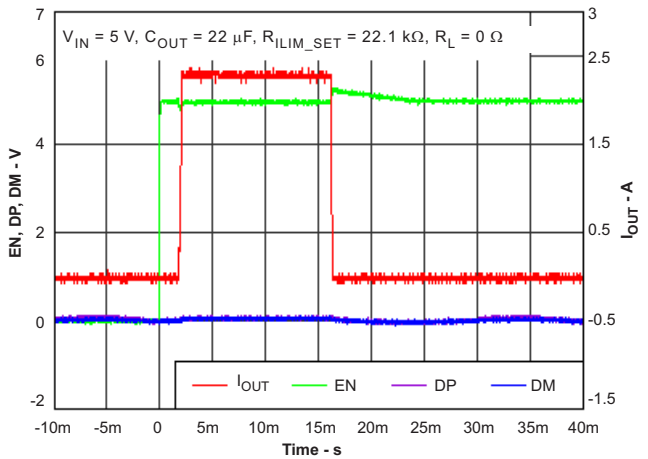

Figure 15. Enable into Short

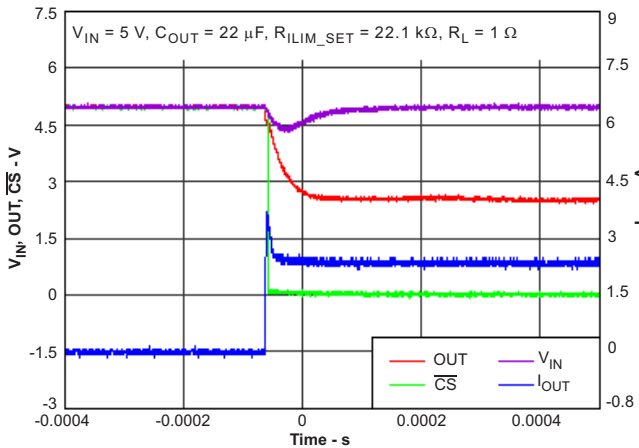

Figure 16. 1-Ω Load Applied

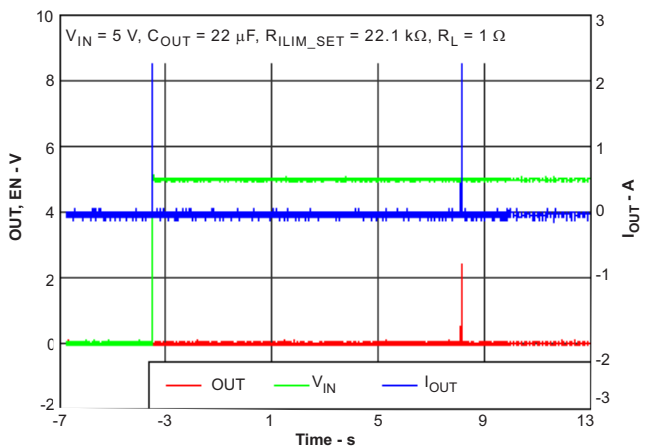

Figure 17. Hiccup Mode While Enabled into 1-Ω Load

PRODUCT PREVIEW

TYPICAL CHARACTERISTICS (continued)

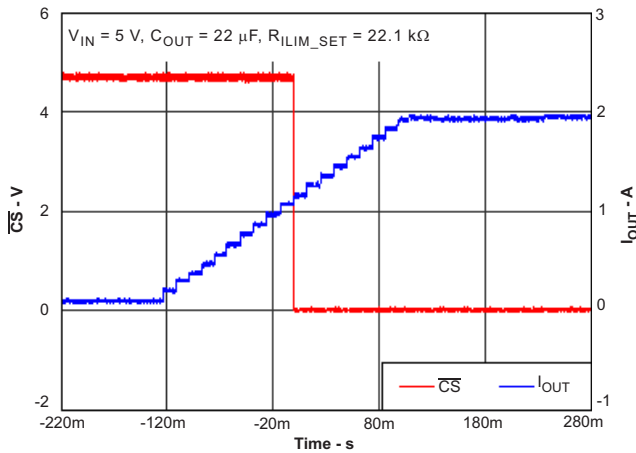

Figure 18. Output Current Sensing Report

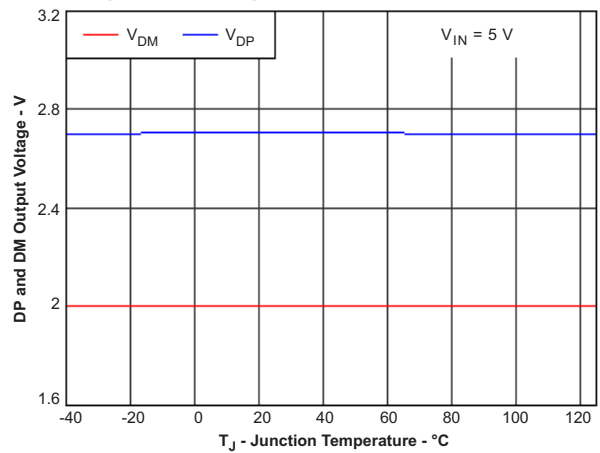

Figure 19. DP and DM Output Voltage vs Temperature

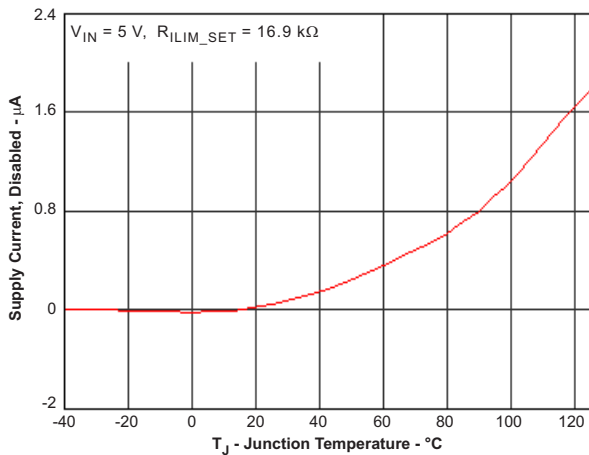

Figure 20. Supply Current Disabled vs Temperature

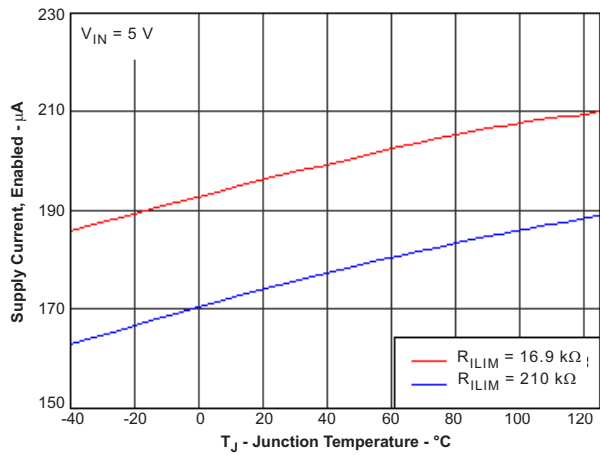

Figure 21. Supply Current Enabled vs Temperature

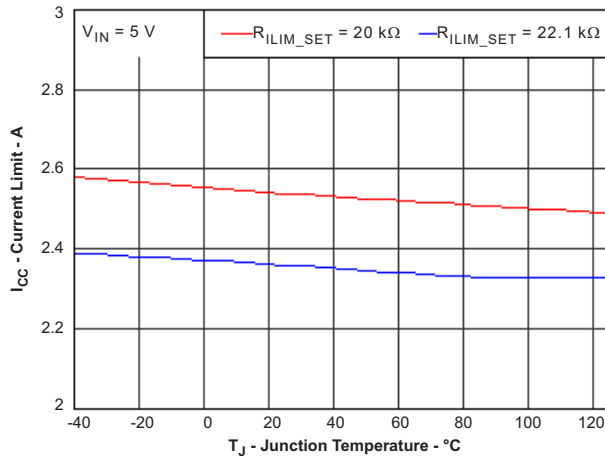

Figure 22. Current Limit vs Temperature

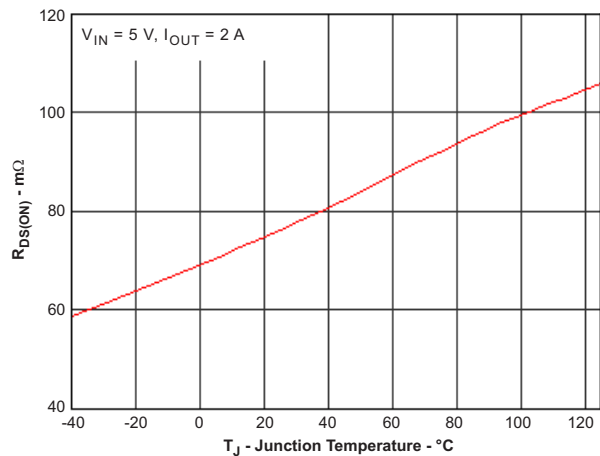

Figure 23. Power Switch On-Resistance ($R_{DS(ON)}$) vs Temperature

PRODUCT PREVIEW

DETAILED DESCRIPTION

Overview

The following overview references various industry standards. It is always recommended to consult the latest standard to ensure the most recent and accurate information.

Rechargeable portable equipment requires an external power source to charge its batteries. USB ports are convenient locations for charging because of an available 5-V power source. Universally accepted standards are required to ensure host and client-side devices meet the power management requirements. Traditionally, USB host ports following the USB 2.0 Specification must provide at least 500 mA to downstream client-side devices. Because multiple USB devices can be attached to a single USB port through a bus-powered hub, it is the responsibility of the client-side device to negotiate the power allotment from the host to guarantee the total current draw does not exceed 500 mA. The TPS2511-Q1 provides 100 mA of current to each USB device. Each USB device can subsequently request more current, which is granted in steps of 100 mA up 500 mA total.. The host may grant or deny the request based on the available current.

Additionally, the success of the USB technology makes the micro-USB connector a popular choice for wall adapter cables. This allows a portable device to charge from both a wall adapter and USB port with only one connector.

One common difficulty has resulted from this. As USB charging has gained popularity, the 500-mA minimum defined by the USB 2.0 Specification or 900 mA defined in the USB 3.0 Specification, has become insufficient for many handsets, tablets and personal media players (PMP) which have a higher rated charging current. Wall adapters and car chargers can provide much more current than 500 mA or 900 mA to fast charge portable devices. Several new standards have been introduced defining protocol handshaking methods that allow host and client devices to acknowledge and draw additional current beyond the 500 mA (defined in the USB 2.0 Specification) or 900 mA (defined in the USB 3.0 Specification) minimum while using a single micro-USB input connector.

The TPS2511-Q1 supports three of the most common protocols:

- USB Battery Charging Specification, Revision 1.2 (BC1.2)
- Chinese Telecommunications Industry Standard YD/T 1591-2009
- Divider Mode

In these protocols there are three types of charging ports defined to provide different charging current to client-side devices. These charging ports are defined as:

- Standard downstream port (SDP)
- Charging downstream port (CDP)
- Dedicated charging port (DCP)

The BC1.2 Specification defines a charging port as a downstream facing USB port that provides power for charging portable equipment.

[Table 1](#) shows different port operating modes according to the BC1.2 Specification.

Table 1. Operating Modes Table

PORT TYPE	SUPPORTS USB 2.0 COMMUNICATION	MAXIMUM ALLOWABLE CURRENT DRAWN BY PORTABLE EQUIPMENT (A)
SDP (USB 2.0)	Yes	0.5
SDP (USB 3.0)	Yes	0.9
CDP	Yes	1.5
DCP	No	1.5

The BC1.2 Specification defines the protocol necessary to allow portable equipment to determine what type of port it is connected to so that it can allot its maximum allowable current drawn. The hand-shaking process is two steps. During step one, the primary detection, the portable equipment outputs a nominal 0.6 V output on its D+ line and reads the voltage input on its D- line. The portable device concludes it is connected to a SDP if the voltage is less than the nominal data detect voltage of 0.3 V. The portable device concludes that it is connected to a Charging Port if the D- voltage is greater than the nominal data detect voltage of 0.3V and less than 0.8 V.

The second step, the secondary detection, is necessary for portable equipment to determine between a CDP and a DCP. The portable device outputs a nominal 0.6 V output on its D- line and reads the voltage input on its D+ line. The portable device concludes it is connected to a CDP if the data line being remains is less than the nominal data detect voltage of 0.3 V. The portable device concludes it is connected to a DCP if the data line being read is greater than the nominal data detect voltage of 0.3V and less than 0.8 V.

Dedicated Charging Port (DCP)

A dedicated charging port (DCP) is a downstream port on a device that outputs power through a USB connector, but is not capable of enumerating a downstream device, which generally allows portable devices to fast charge at their maximum rated current. A USB charger is a device with a DCP, such as a wall adapter or car power adapter. A DCP is identified by the electrical characteristics of its data lines. The following DCP identification circuits are usually used to meet the handshaking detections of different portable devices.

Short the D+ Line to the D- Line

The USB BC1.2 Specification and the Chinese Telecommunications Industry Standard YD/T 1591-2009 define that the D+ and D- data lines should be shorted together with a maximum series impedance of 200 Ω. This is shown in [Figure 24](#).

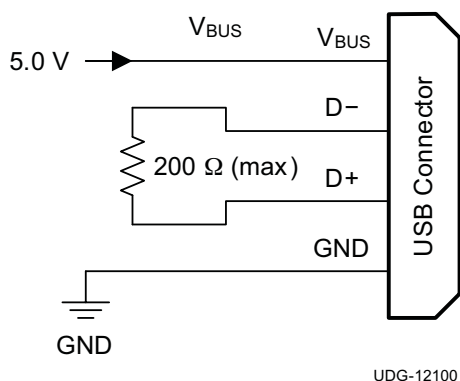

Figure 24. DCP Short Mode

Divider1 (DCP Applying 2.0 V on D+ Line and 2.7 V on D- Line) or Divider2 (DCP Applying 2.7 V on D+ Line and 2.0 V on D- Line)

There are two charging schemes for divider DCP. They are named after Divider1 and Divider2 DCPs that are shown in [Figure 25](#) and [Figure 26](#). The Divider1 charging scheme is used for 5-W adapters, Divider1 applies 2.0 V to the D+ line and 2.7 V to the D- data line. The Divider2 charging scheme is used for 10-W adapters and applies 2.7 V on the D+ line and 2.0 V is applied on the D- line.

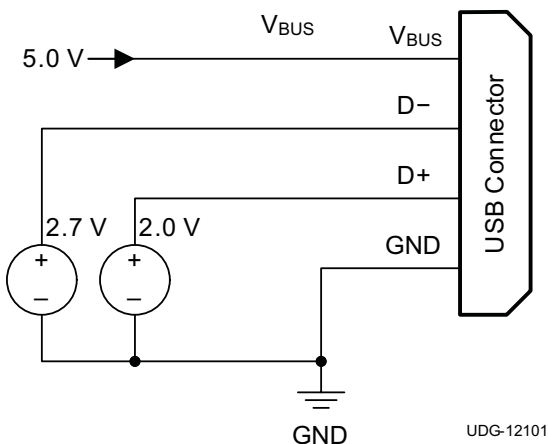

Figure 25. Divider1 DCP

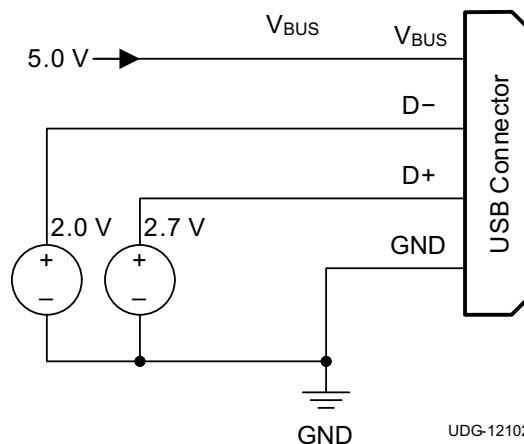

Figure 26. Divider2 DCP

Applying 1.2 V to the D+ Line and 1.2 V to the D– Line

As shown in Figure 27, some tablet USB chargers require 1.2 V on the shorted data lines of the USB connector. The maximum resistance between the D+ line and the D– line is 200 Ω .

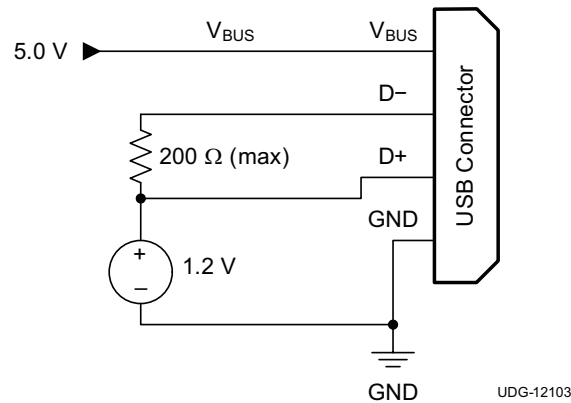

Figure 27. DCP Applying 1.2 V to the D+ Line and 1.2 V to the D– Line

The TPS2511-Q1 is a combination of a current-limiting USB power switch and an USB DCP identification controller. Applications include vehicle power charger, wall adapters with USB DCP and other USB chargers. The TPS2511-Q1 DCP controller has the auto-detect feature that monitors the D+ and D– line voltages of the USB connector, providing the correct electrical characteristics on the DP and DM pins for the correct detections of compliant portable devices to fast charge. These portable devices include smart phones, 5-V tablets and personal media players.

The TPS2511-Q1 power-distribution switch is intended for applications where heavy capacitive loads and short-circuits are likely to be encountered, incorporating a 70-m Ω , N-channel MOSFET in a single package. This device provides hiccup mode when in current limit and OUT voltage is less than 3.8 V (typ) or an over temperature protection occurs under an overload condition. Hiccup mode operation can reduce the output short-circuit current down to several milliamperes. The TPS2511-Q1 provides a logic-level enable EN pin to control the device turn-on and tuen-off and an open drain output \overline{CS} for compensating V_{BUS} to account for cable $I \times R$ voltage loss.

DCP Auto-Detect

The TPS2511-Q1 integrates an *auto-detect* feature to support divider mode, short mode and 1.2 V / 1.2 V mode. If a divider device is attached, 2.7 V is applied to the DP pin and 2.0 V is applied to the DM pin. If a BC1.2-compliant device is attached, the TPS2511-Q1 automatically switches into short mode. If a device compliant with the 1.2 V / 1.2 V charging scheme is attached, 1.2 V is applied on both the DP pin and the DM pin. The functional diagram of DCP auto-detect feature is shown in Figure 28.

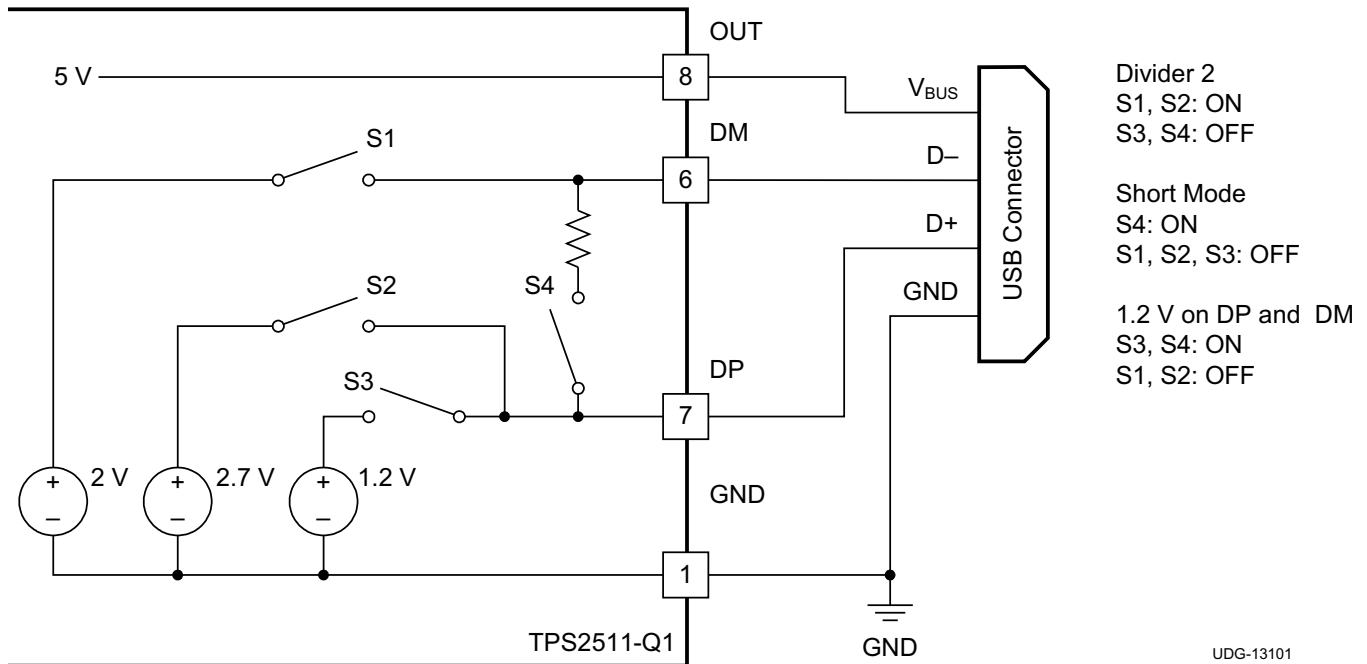

Figure 28. TPS2511-Q1 DCP Auto-Detect Functional Diagram

Overcurrent Protection

During an overload condition, the TPS2511-Q1 maintains a constant output current and reduces the output voltage accordingly. If the output voltage falls below 3.8 V for 16 ms, the TPS2511-Q1 turns off the output for a period of 12 seconds as shown in Figure 29. This operation is referred to as hiccup mode. The device stays in hiccup mode (power cycling) until the overload condition is removed. Therefore the average output current is significantly reduced to greatly improve the thermal stress of the device while the OUT pin is shorted.

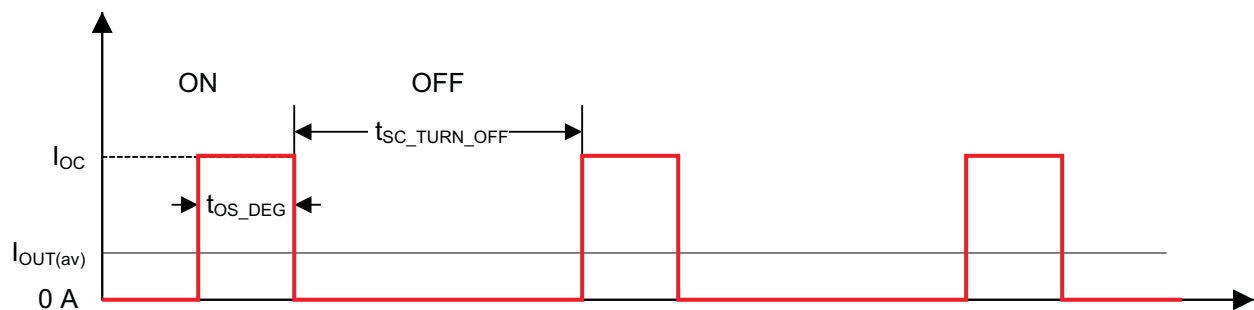

Figure 29. OUT Pin Short-Circuit Current in Hiccup Mode

Two possible overload conditions can occur. In the first condition, the output has been shorted before the device is enabled or before the voltage of IN has been applied. The TPS2511-Q1 senses the short and immediately switches into hiccup mode of constant-current limiting. In the second condition, a short or an overload occurs while the device is enabled. At the instant the overload occurs, high currents may flow for several microseconds before the current-limit circuit can react. The device operates in constant-current mode for a period of 16 ms after the current-limit circuit has responded, then switches into hiccup mode (power cycling).

Current-Limit Threshold

The TPS2511-Q1 has a current-limiting threshold that is externally programmed with a resistor. Equation 1 and Figure 30 help determine the typical current-limit threshold:

$$I_{OS_TYP} = \frac{51228}{R_{ILIM}}$$

where

- I_{OS_TYP} is in mA and R_{ILIM} is in $k\Omega$
 - I_{OS_TYP} has a better accuracy if R_{ILIM} is less than 210 $k\Omega$
- (1)

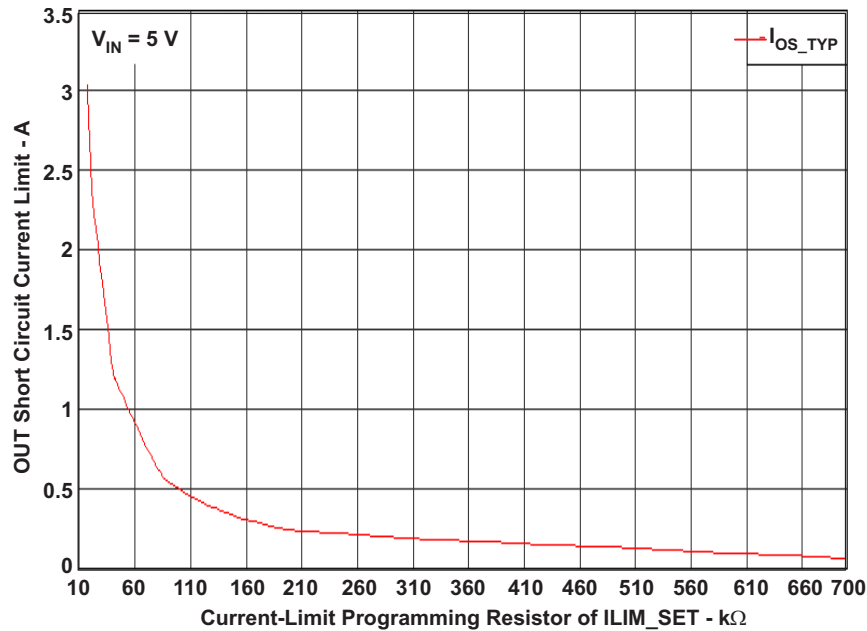

Figure 30. Typical Current Limit vs Programming Resistor

Current Sensing Report (\overline{CS})

The \overline{CS} open-drain output is asserted immediately when the OUT pin current is more than about half of the current limit set by a resistor on ILIM_SET pin. Built-in hysteresis improves the ability to resist current noise on the OUT pin. The \overline{CS} output is active low. The recommended operating sink current is less than 2 mA and maximum sink current is 10 mA.

Undervoltage Lockout (UVLO) and Enable (EN)

The undervoltage lockout (UVLO) circuit disables the power switch and other functional circuits until the input voltage reaches the UVLO turn-on threshold. Built-in hysteresis prevents unwanted oscillations on the output due to input voltage drop from large current surges.

The logic input of the EN pin disables all of the internal circuitry while maintaining the power switch off. A logic-high input on the EN pin enables the driver, control circuits, and power switch. The EN input voltage is compatible with both TTL and CMOS logic levels.

TPS2511-Q1

SLUSBK5 – JUNE 2013

www.ti.com

Soft-Start, Reverse Blocking and Discharge Output

The power MOSFET driver incorporates circuitry that controls the rise and fall times of the output voltage to limit large current and voltage surges on the input supply, and provides built-in soft-start functionality. The TPS2511-Q1 power switch blocks current from the OUT pin to the IN pin when turned off by the UVLO or disabled. The TPS2511-Q1 includes an output discharge function. A 500- Ω (typ.) discharge resistor dissipates stored charge and leakage current on the OUT pin when the device is in UVLO or disabled. However as this circuit is biased from the IN pin, the output discharge is not active when the input approaches 0 V.

Thermal Sense

The TPS2511-Q1 provides thermal protection from two independent thermal sensing circuits that monitor the operating temperature of the power distribution switch and turn off for 12 seconds (typ) if the temperature exceeds recommended operating conditions. The device operates in constant-current mode during an over-current condition and OUT pin voltage is above 3.8 V (typ), which has a relatively large voltage drop across power switch. The power dissipation in the package is proportional to the voltage drop across the power switch, so the junction temperature rises during the over-current condition. The first thermal sensor turns off the power switch when the die temperature exceeds 135°C and the device is within the current limit. The second thermal sensor turns off the power switch when the die temperature exceeds 155°C regardless of whether the power switch is in current limit. Hysteresis is built into both thermal sensors, and the switch turns on after the device has cooled approximately 10°C. The switch continues to cycle off and on until the fault is removed.

PRODUCT PREVIEW

APPLICATION INFORMATION

Programming the Current Limit Threshold

The user-programmable R_{ILIM} resistor on the ILIMIT_SET pin sets the current limit. The TPS2511-Q1 uses an internal regulation loop to provide a regulated voltage on the ILIM_SET pin. The current-limiting threshold is proportional to the current sourced out of the ILIM_SET pin. The recommended 1% resistor range for R_{ILIM} is between 16.9 k Ω and 750 k Ω to ensure stability of the internal regulation loop, although not exceeding 210 k Ω results in a better accuracy. Many applications require that the minimum current limit remain above a certain current level or that the maximum current limit remain below a certain current level, so it is important to consider the tolerance of the overcurrent threshold when selecting a value for R_{ILIM} . The Equation 2 and Equation 3 calculate the resulting overcurrent thresholds for a given external resistor value (R_{ILIM}). The traces routing the R_{ILIM} resistor to the TPS2511-Q1 should be as short as possible to reduce parasitic effects on the current limit accuracy. The equations and the graph below can be used to estimate the minimum and maximum variation of the current limit threshold for a predefined resistor value. This variation disregards the inaccuracy of the resistor itself.

$$I_{OS_MIN} = \frac{51228}{R_{ILIM}^{1.030}}$$

where

- I_{OS_MIN} is in mA
- R_{ILIM} is in k Ω

(2)

$$I_{OS_MAX} = \frac{51228}{R_{ILIM}^{0.967}}$$

where

- I_{OS_MAX} is in mA
- R_{ILIM} is in k Ω

(3)

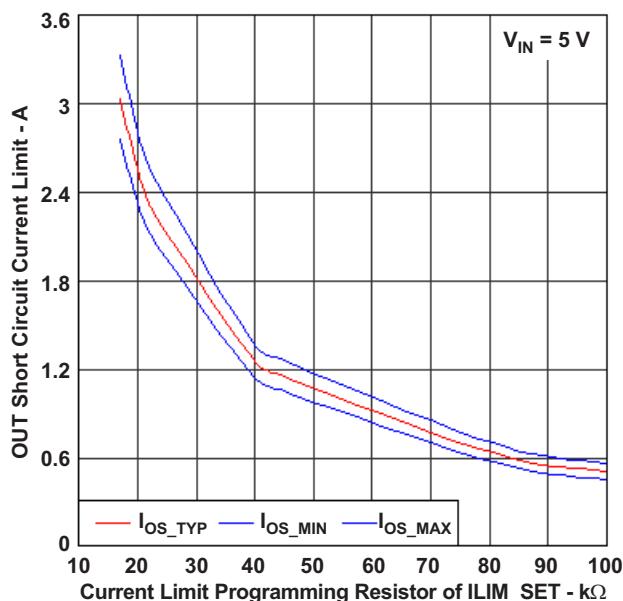

Figure 31. Current Limit Threshold vs Current Limit Resistance

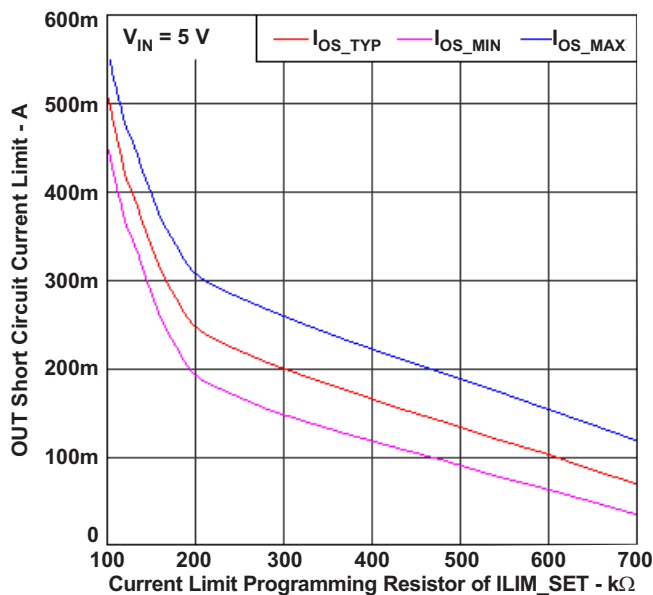

Figure 32. Current Limit Threshold vs Current Limit Resistance

Current Limit Setpoint Example

In the following example, choose the ILIM_SET resistor to ensure that TPS2511-Q1 does not trip off under worst case conditions of current limit and resistor tolerance (assume 1% resistor tolerance). For this example, $I_{OS_MIN} = 2100$ mA.

$$I_{OS_MIN} = \frac{51228}{R_{ILIM}^{1.03}} = 2100 \text{ mA} \quad (4)$$

$$R_{ILIM} = \left(\frac{51228}{I_{OS_MIN}} \right)^{\frac{1}{1.03}} = \left(\frac{51228}{2100} \right)^{\frac{1}{1.03}} = 22.227 \text{ k}\Omega \quad (5)$$

Including resistor tolerance, target nominal resistance value:

$$R_{ILIM} = \frac{22.227 \text{ k}\Omega}{1.01} = 22.007 \text{ k}\Omega \quad (6)$$

Choose:

$$R_{ILIM} = 22.0 \text{ k}\Omega \quad (7)$$

V_{BUS} Voltage Drop Compensation

Figure 33 shows a USB charging design using the TPS2511-Q1. In general V_{BUS} has some voltage loss due to USB cable resistance and TPS2511-Q1 power switch on-state resistance. The sum of voltage loss is likely several hundred millivolts from $5V_{OUT}$ to V_{PD_IN} that is the input voltage of PD while the high charging current charges the PD. For example, in Figure 34, assuming that the loss resistance is 170 m Ω (includes 100 m Ω of USB cable resistance and 70 m Ω of power switch resistance) and $5V_{OUT}$ is 5.0 V, the input voltage of PD (V_{PD_IN}) is about 4.66 V at 2.0 A. (see Figure 34)

The charging current of most portable devices is less than their maximum charging current while V_{PD_IN} is less than the certain voltage value. Furthermore actual charging current of PD decreases with input voltage falling. Therefore, a portable devices cannot accomplish a fast charge with its maximum charging rated current if V_{BUS} voltage drop across the power path is not compensated at the high charging current. The TPS2511-Q1 provides CS pin to report the high charging current for USB chargers to increase the $5V_{OUT}$ voltage. This is shown by the solid lines of Figure 34.

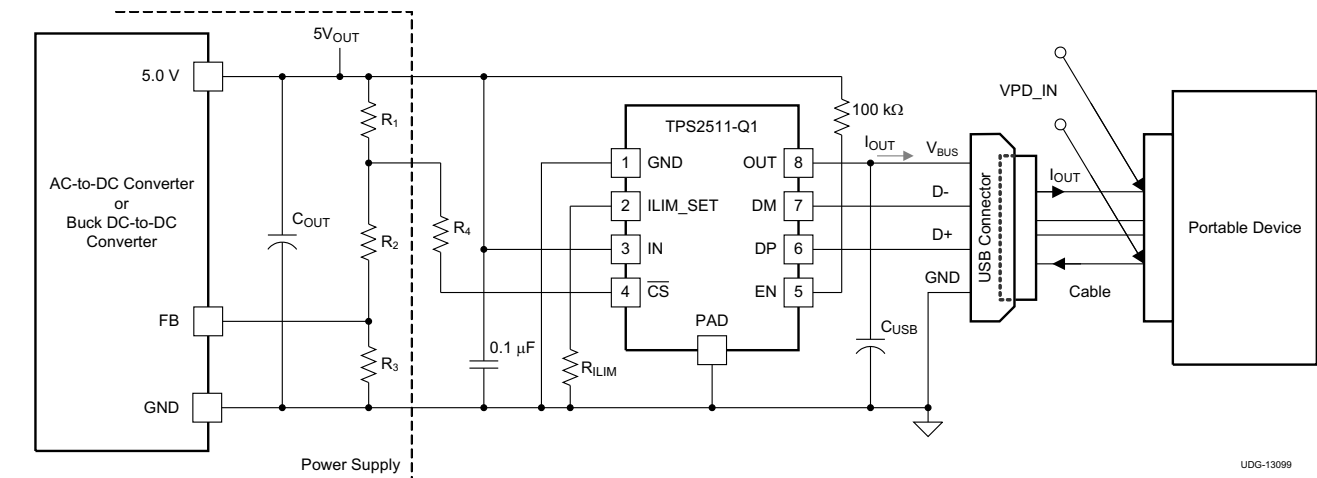

Figure 33. TPS2511-Q1 Charging System Schematic Diagram

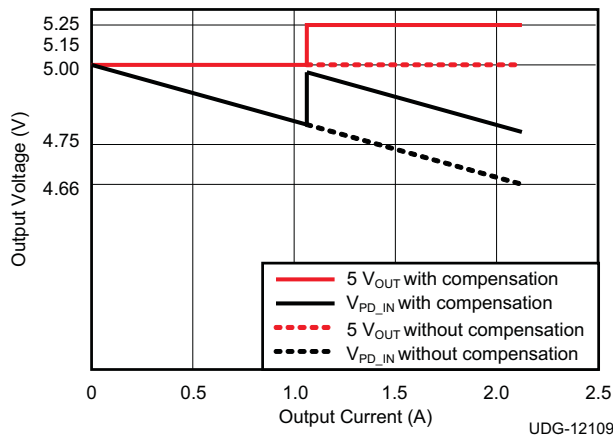

Figure 34. TPS2511-Q1 \overline{CS} Function

Equation 8 through Equation 11 refer to Figure 33.

The power supply output voltage is calculated in Equation 8.

$$5V_{OUT} = \frac{(R_1 + R_2 + R_3) \times V_{FB}}{R_3} \quad (8)$$

$5V_{OUT}$ and V_{FB} are known. If R_3 is given and R_1 is fixed, R_2 can be calculated. The $5V_{OUT}$ voltage change with compensation is shown in Equation 9 and Equation 10.

$$\Delta V = \frac{(R_2 + R_3) \times R_1 \times V_{FB}}{R_3 \times R_4} \quad (9)$$

$$\Delta V = \left(\frac{5V_{OUT}}{V_{FB}} - \frac{R_1}{R_3} \right) \frac{R_1 \times V_{FB}}{R_4} \quad (10)$$

If R_1 is less than R_3 , then Equation 10 can be simplified as Equation 11.

$$\Delta V \approx \frac{5V_{OUT} \times R_1}{R_4} \quad (11)$$

Divide Mode Selection of 5-W and 10-W USB Chargers

The TPS2511-Q1 provides two types of connections between the DP pin and the DM pin and between the D+ data line and the D– data line of the USB connector for a 5-W USB charger and a 10-W USB charger with a single USB port. For a 5-W USB charger, the DP pin is connected to the D– line and the DM pin is connected to the D+ line. This is shown in Figure 37 and Figure 38. It is necessary to apply DP and DM to D+ and D– of USB connector for 10-W USB chargers. See Figure 35 and Figure 36. Table 2. shows different charging schemes for both 5-W and 10-W USB charger solutions

Table 2. Charging Schemes for 5-W and 10-W USB Chargers

USB CHARGER TYPE	CONTAINING CHARGING SCHEMES		
5-W	Divider1	1.2 V on both D+ and D– Lines	BC1.2 DCP
10-W	Divider2	1.2 V on both D+ and D– Lines	BC1.2 DCP

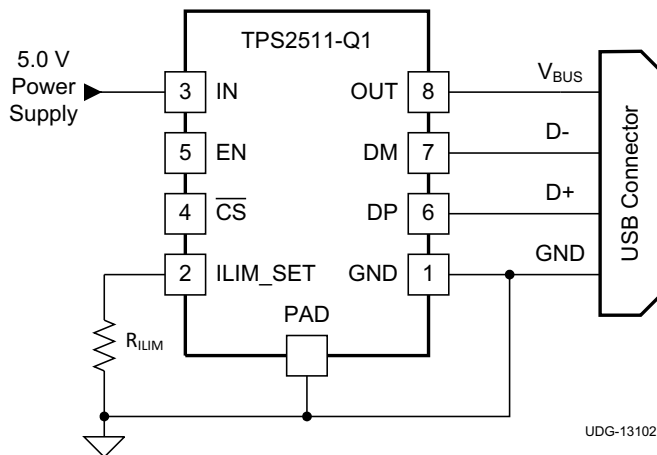

UDG-13102

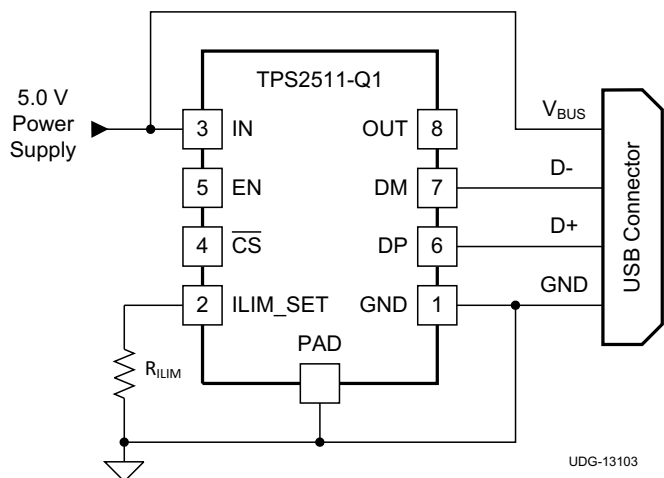
Figure 35. 10-W USB Charger Application with Power Switch

UDG-13103

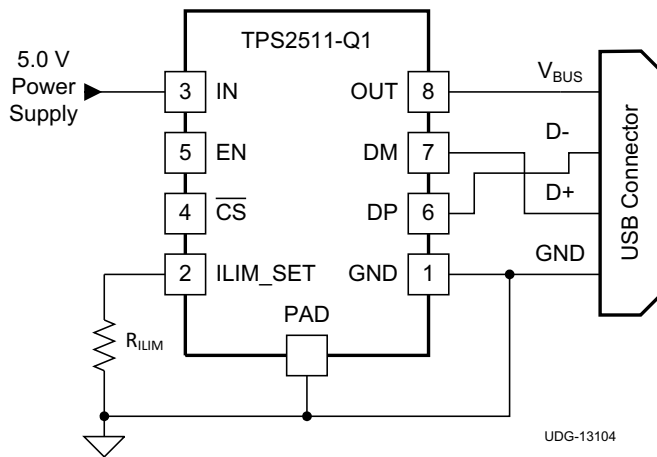
Figure 36. 10-W USB Charger Application without Power Switch

UDG-13104

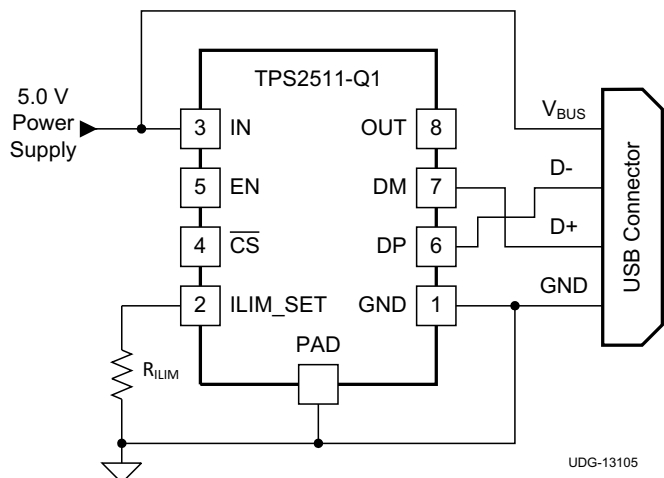
Figure 37. 5-W USB Charger Application with Power Switch

UDG-13105

Figure 38. 5-W USB Charger Application without Power Switch

Layout Guidelines

- TPS2511-Q1 placement.** Place the TPS2511-Q1 near the USB output connector and at least 22- μ F OUT pin filter capacitor. Connect the exposed Power PAD to the GND pin and to the system ground plane using a via array.
- IN pin bypass capacitance.** Place the 0.1- μ F bypass capacitor near the IN pin and make the connection using a low-inductance trace.
- ILIM_SET pin connection.** Current limit set point accuracy can be compromised by stray leakage from a higher voltage source to the ILIM_SET pin. Ensure that there is adequate spacing between IN pin copper/trace and ILIM_SET pin trace to prevent contaminant buildup during the PCB assembly process. The traces routing the R_{ILIM} resistor to the device should be as short as possible to reduce parasitic effects on the current-limit accuracy.

PACKAGING INFORMATION

Orderable Device	Status (1)	Package Type	Package Drawing	Pins	Package Qty	Eco Plan (2)	Lead/Ball Finish	MSL Peak Temp (3)	Op Temp (°C)	Device Marking (4/5)	Samples
TPS2511QDGNQ1	PREVIEW	MSOP-PowerPAD	DGN	8		Green (RoHS & no Sb/Br)	CU NIPDAUAG	Level-2-260C-1 YEAR	-40 to 125	2511Q	
TPS2511QDGNRQ1	PREVIEW	MSOP-PowerPAD	DGN	8		Green (RoHS & no Sb/Br)	CU NIPDAUAG	Level-2-260C-1 YEAR	-40 to 125	2511Q	

(1) The marketing status values are defined as follows:

ACTIVE: Product device recommended for new designs.

LIFEBUY: TI has announced that the device will be discontinued, and a lifetime-buy period is in effect.

NRND: Not recommended for new designs. Device is in production to support existing customers, but TI does not recommend using this part in a new design.

PREVIEW: Device has been announced but is not in production. Samples may or may not be available.

OBsolete: TI has discontinued the production of the device.

(2) Eco Plan - The planned eco-friendly classification: Pb-Free (RoHS), Pb-Free (RoHS Exempt), or Green (RoHS & no Sb/Br) - please check <http://www.ti.com/productcontent> for the latest availability information and additional product content details.

TBD: The Pb-Free/Green conversion plan has not been defined.

Pb-Free (RoHS): TI's terms "Lead-Free" or "Pb-Free" mean semiconductor products that are compatible with the current RoHS requirements for all 6 substances, including the requirement that lead not exceed 0.1% by weight in homogeneous materials. Where designed to be soldered at high temperatures, TI Pb-Free products are suitable for use in specified lead-free processes.

Pb-Free (RoHS Exempt): This component has a RoHS exemption for either 1) lead-based flip-chip solder bumps used between the die and package, or 2) lead-based die adhesive used between the die and leadframe. The component is otherwise considered Pb-Free (RoHS compatible) as defined above.

Green (RoHS & no Sb/Br): TI defines "Green" to mean Pb-Free (RoHS compatible), and free of Bromine (Br) and Antimony (Sb) based flame retardants (Br or Sb do not exceed 0.1% by weight in homogeneous material)

(3) MSL, Peak Temp. -- The Moisture Sensitivity Level rating according to the JEDEC industry standard classifications, and peak solder temperature.

(4) There may be additional marking, which relates to the logo, the lot trace code information, or the environmental category on the device.

(5) Multiple Device Markings will be inside parentheses. Only one Device Marking contained in parentheses and separated by a "~" will appear on a device. If a line is indented then it is a continuation of the previous line and the two combined represent the entire Device Marking for that device.

Important Information and Disclaimer: The information provided on this page represents TI's knowledge and belief as of the date that it is provided. TI bases its knowledge and belief on information provided by third parties, and makes no representation or warranty as to the accuracy of such information. Efforts are underway to better integrate information from third parties. TI has taken and continues to take reasonable steps to provide representative and accurate information but may not have conducted destructive testing or chemical analysis on incoming materials and chemicals. TI and TI suppliers consider certain information to be proprietary, and thus CAS numbers and other limited information may not be available for release.

In no event shall TI's liability arising out of such information exceed the total purchase price of the TI part(s) at issue in this document sold by TI to Customer on an annual basis.

OTHER QUALIFIED VERSIONS OF TPS2511-Q1 :

- Catalog: [TPS2511](#)

NOTE: Qualified Version Definitions:

- Catalog - TI's standard catalog product

DGN (S-PDSO-G8)

PowerPAD™ PLASTIC SMALL OUTLINE



- NOTES:
- A. All linear dimensions are in millimeters.
 - B. This drawing is subject to change without notice.
 - C. Body dimensions do not include mold flash or protrusion.
 - D. This package is designed to be soldered to a thermal pad on the board. Refer to Technical Brief, PowerPad Thermally Enhanced Package, Texas Instruments Literature No. SLMA002 for information regarding recommended board layout. This document is available at www.ti.com <<http://www.ti.com>>.
 - E. See the additional figure in the Product Data Sheet for details regarding the exposed thermal pad features and dimensions.
 - F. Falls within JEDEC MO-187 variation AA-T

PowerPAD is a trademark of Texas Instruments.

IMPORTANT NOTICE

Texas Instruments Incorporated and its subsidiaries (TI) reserve the right to make corrections, enhancements, improvements and other changes to its semiconductor products and services per JESD46, latest issue, and to discontinue any product or service per JESD48, latest issue. Buyers should obtain the latest relevant information before placing orders and should verify that such information is current and complete. All semiconductor products (also referred to herein as "components") are sold subject to TI's terms and conditions of sale supplied at the time of order acknowledgment.

TI warrants performance of its components to the specifications applicable at the time of sale, in accordance with the warranty in TI's terms and conditions of sale of semiconductor products. Testing and other quality control techniques are used to the extent TI deems necessary to support this warranty. Except where mandated by applicable law, testing of all parameters of each component is not necessarily performed.

TI assumes no liability for applications assistance or the design of Buyers' products. Buyers are responsible for their products and applications using TI components. To minimize the risks associated with Buyers' products and applications, Buyers should provide adequate design and operating safeguards.

TI does not warrant or represent that any license, either express or implied, is granted under any patent right, copyright, mask work right, or other intellectual property right relating to any combination, machine, or process in which TI components or services are used. Information published by TI regarding third-party products or services does not constitute a license to use such products or services or a warranty or endorsement thereof. Use of such information may require a license from a third party under the patents or other intellectual property of the third party, or a license from TI under the patents or other intellectual property of TI.

Reproduction of significant portions of TI information in TI data books or data sheets is permissible only if reproduction is without alteration and is accompanied by all associated warranties, conditions, limitations, and notices. TI is not responsible or liable for such altered documentation. Information of third parties may be subject to additional restrictions.

Resale of TI components or services with statements different from or beyond the parameters stated by TI for that component or service voids all express and any implied warranties for the associated TI component or service and is an unfair and deceptive business practice. TI is not responsible or liable for any such statements.

Buyer acknowledges and agrees that it is solely responsible for compliance with all legal, regulatory and safety-related requirements concerning its products, and any use of TI components in its applications, notwithstanding any applications-related information or support that may be provided by TI. Buyer represents and agrees that it has all the necessary expertise to create and implement safeguards which anticipate dangerous consequences of failures, monitor failures and their consequences, lessen the likelihood of failures that might cause harm and take appropriate remedial actions. Buyer will fully indemnify TI and its representatives against any damages arising out of the use of any TI components in safety-critical applications.

In some cases, TI components may be promoted specifically to facilitate safety-related applications. With such components, TI's goal is to help enable customers to design and create their own end-product solutions that meet applicable functional safety standards and requirements. Nonetheless, such components are subject to these terms.

No TI components are authorized for use in FDA Class III (or similar life-critical medical equipment) unless authorized officers of the parties have executed a special agreement specifically governing such use.

Only those TI components which TI has specifically designated as military grade or "enhanced plastic" are designed and intended for use in military/aerospace applications or environments. Buyer acknowledges and agrees that any military or aerospace use of TI components which have **not** been so designated is solely at the Buyer's risk, and that Buyer is solely responsible for compliance with all legal and regulatory requirements in connection with such use.

TI has specifically designated certain components as meeting ISO/TS16949 requirements, mainly for automotive use. In any case of use of non-designated products, TI will not be responsible for any failure to meet ISO/TS16949.

Products

Audio	www.ti.com/audio
Amplifiers	amplifier.ti.com
Data Converters	dataconverter.ti.com
DLP® Products	www.dlp.com
DSP	dsp.ti.com
Clocks and Timers	www.ti.com/clocks
Interface	interface.ti.com
Logic	logic.ti.com
Power Mgmt	power.ti.com
Microcontrollers	microcontroller.ti.com
RFID	www.ti-rfid.com
OMAP Applications Processors	www.ti.com/omap
Wireless Connectivity	www.ti.com/wirelessconnectivity

Applications

Automotive and Transportation	www.ti.com/automotive
Communications and Telecom	www.ti.com/communications
Computers and Peripherals	www.ti.com/computers
Consumer Electronics	www.ti.com/consumer-apps
Energy and Lighting	www.ti.com/energy
Industrial	www.ti.com/industrial
Medical	www.ti.com/medical
Security	www.ti.com/security
Space, Avionics and Defense	www.ti.com/space-avionics-defense
Video and Imaging	www.ti.com/video

TI E2E Community

e2e.ti.com