

## 4.5-V to 18-V, 3-A OUTPUT SYNCHRONOUS STEP DOWN SWITCHER WITH INTEGRATED FET ( SWIFT™)

Check for Samples: [TPS54325](#)

### FEATURES

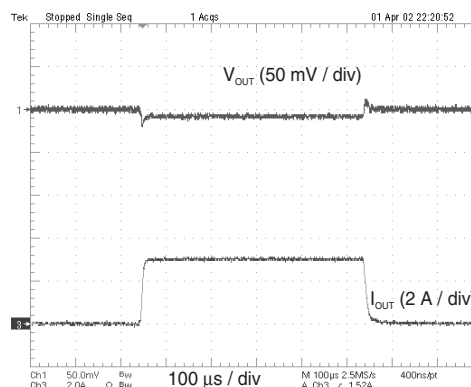
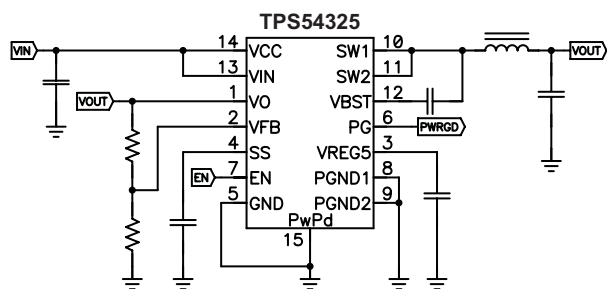
- D-CAP2™ Mode Enables Fast Transient Response
- Low Output Ripple and Allows Ceramic Output Capacitor
- Wide  $V_{CC}$  Input Voltage Range: 4.5 V to 18 V
- Wide  $V_{IN}$  Input Voltage Range: 2.0 V to 18 V
- Output Voltage Range: 0.76 V to 5.5 V
- Highly Efficient Integrated FET's Optimized for Lower Duty Cycle Applications
  - 120 m $\Omega$  (High Side) and 70 m $\Omega$  (Low Side)
- High Efficiency, less than 10  $\mu$ A at shutdown
- High Initial Bandgap Reference Accuracy
- Adjustable Soft Start
- Pre-Biased Soft Start
- 700-kHz Switching Frequency ( $f_{sw}$ )
- Cycle By Cycle Over Current Limit
- Power Good Output

### APPLICATIONS

- Wide Range of Applications for Low Voltage System
  - Digital TV Power Supply
  - High Definition Blue-ray Disc™ Players
  - Networking Home Terminal
  - Digital Set Top Box (STB)

### DESCRIPTION

The TPS54325 is an adaptive on-time D-CAP2™ mode synchronous buck converter. The TPS54325 enables system designers to complete the suite of various end equipment's power bus regulators with a cost effective, low component count, low standby current solution. The main control loop for the TPS54325 uses the D-CAP2™ mode control which provides a very fast transient response with no external components. The TPS54325 also has a proprietary circuit that enables the device to adapt to both low equivalent series resistance (ESR) output capacitors, such as POSCAP or SP-CAP, and ultra-low ESR ceramic capacitors. The device operates from 4.5-V to 18-V  $V_{CC}$  input, and from 2.0-V to 18-V  $V_{IN}$  input power supply voltage. The output voltage can be programmed between 0.76 V and 5.5 V. The device also features an adjustable slow start time and a power good function. The TPS54325 is available in the 14 pin HTSSOP package, and designed to operate from  $-40^{\circ}\text{C}$  to  $85^{\circ}\text{C}$ .



Please be aware that an important notice concerning availability, standard warranty, and use in critical applications of Texas Instruments semiconductor products and disclaimers thereto appears at the end of this data sheet.

SWIFT, D-CAP2, PowerPAD are trademarks of Texas Instruments.  
Blue-ray Disc is a trademark of Blu-ray Disc.

**ORDERING INFORMATION<sup>(1)</sup>**

T <sub>A</sub>	PACKAGE <sup>(2)</sup> <sup>(3)</sup>	ORDERABLE PART NUMBER	TRANSPORT MEDIA, QUANTITY	ECO PLAN
-45°C to 85°C	PowerPAD™ (HTSSOP) – PWP	TPS54325PWP	Tube	Green (RoHS & no Sb/Br)
		TPS54325PWPR	Tape and Reel	

- (1) For the most current package and ordering information, see the Package Option Addendum at the end of this document, or see the TI web site at [www.ti.com](http://www.ti.com).
- (2) Package drawings, thermal data, and symbolization are available at [www.ti.com/packaging](http://www.ti.com/packaging).
- (3) All package options have Cu NIPDAU lead/ball finish.

**ABSOLUTE MAXIMUM RATINGS**

over operating free-air temperature range (unless otherwise noted) <sup>(1)</sup>

		VALUE	UNIT	
V <sub>I</sub>	Input voltage range	V <sub>IN</sub> , V <sub>CC</sub> , EN	-0.3 to 20	V
		V <sub>BST</sub>	-0.3 to 26	V
		V <sub>BST</sub> (vs SW1, SW2)	-0.3 to 6.5	V
		V <sub>FB</sub> , V <sub>O</sub> , SS, PG	-0.3 to 6.5	V
		SW1, SW2	-2 to 20	V
		SW1, SW2 (10 ns transient)	-3 to 20	V
V <sub>O</sub>	Output voltage range	V <sub>REG5</sub>	-0.3 to 6.5	V
		P <sub>GND1</sub> , P <sub>GND2</sub>	-0.3 to 0.3	V
V <sub>diff</sub>	Voltage from GND to POWERPAD	-0.2 to 0.2	V	
ESD rating	Electrostatic discharge	Human Body Model (HBM)	2	kV
		Charged Device Model (CDM)	500	V
T <sub>J</sub>	Operating junction temperature	-40 to 150	°C	
T <sub>stg</sub>	Storage temperature	-55 to 150	°C	

- (1) Stresses beyond those listed under *absolute maximum ratings* may cause permanent damage to the device. These are stress ratings only, and functional operation of the device at these or any other conditions beyond those indicated under *recommended operating conditions* is not implied. Exposure to absolute-maximum-rated conditions for extended periods may affect device reliability.

**THERMAL CHARACTERISTICS**

over operating free-air temperature range (unless otherwise noted)

THERMAL METRIC <sup>(1)</sup>		MIN	TYP	MAX	UNIT
θ <sub>JA</sub>	Junction-to-ambient thermal resistance		55.6		°C/W
θ <sub>JCtop</sub>	Junction-to-case (top) thermal resistance		51.3		°C/W
θ <sub>JB</sub>	Junction-to-board thermal resistance		26.4		°C/W
Ψ <sub>JT</sub>	Junction-to-top characterization parameter		1.8		°C/W
Ψ <sub>JB</sub>	Junction-to-board characterization parameter		20.6		°C/W
θ <sub>JCbot</sub>	Junction-to-case (bottom) thermal resistance		4.3		°C/W

- (1) For more information about traditional and new thermal metrics, see the IC Package Thermal Metrics application report ([SPRA953](http://www.ti.com/lit/zip/Spra953)).

## RECOMMENDED OPERATING CONDITIONS

over operating free-air temperature range (unless otherwise noted)

		MIN	MAX	UNIT	
V <sub>CC</sub>	Supply input voltage range	4.5	18	V	
V <sub>IN</sub>	Power input voltage range	2	18	V	
V <sub>I</sub>	Input voltage range	V <sub>BST</sub>	-0.1	24	V
		V <sub>BST</sub> (vs SW1, SW2)	-0.1	6	
		SS, PG	-0.1	6	
		EN	-0.1	18	
		V <sub>O</sub> , V <sub>FB</sub>	-0.1	5.5	
		SW1, SW2	-1.8	18	
		SW1, SW2 (10 ns transient)	-3	18	
	P <sub>GND1</sub> , P <sub>GND2</sub>	-0.1	0.1		
V <sub>O</sub>	Output voltage range	V <sub>REG5</sub>	-0.1	6	V
I <sub>O</sub>	Output current range	I <sub>VREG5</sub>	0	10	mA
T <sub>A</sub>	Operating free-air temperature	-40	85	°C	
T <sub>J</sub>	Operating junction temperature	-40	125	°C	

## ELECTRICAL CHARACTERISTICS

 over operating free-air temperature range, V<sub>CC</sub>, V<sub>IN</sub> = 12 V (unless otherwise noted)

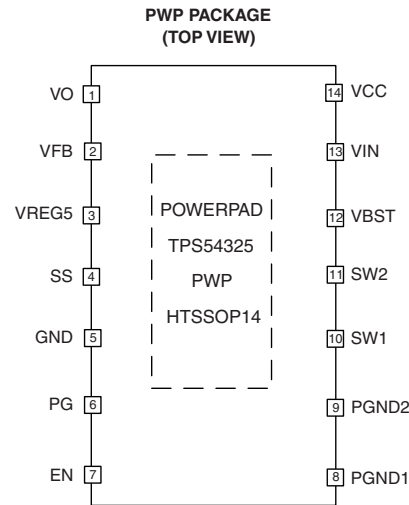
PARAMETER		TEST CONDITIONS	MIN	TYP	MAX	UNIT
<b>SUPPLY CURRENT</b>						
I <sub>VCC</sub>	Operating - non-switching supply current	V <sub>CC</sub> current, T <sub>A</sub> = 25°C, EN = 5 V, V <sub>FB</sub> = 0.8 V		850	1300	μA
I <sub>VCCSDN</sub>	Shutdown supply current	V <sub>CC</sub> current, T <sub>A</sub> = 25°C, EN = 0 V			10	μA
<b>LOGIC THRESHOLD</b>						
V <sub>ENH</sub>	EN high-level input voltage	EN	1.6			V
V <sub>ENL</sub>	EN low-level input voltage	EN			0.4	V
<b>V<sub>FB</sub> VOLTAGE AND DISCHARGE RESISTANCE</b>						
V <sub>FBTH</sub>	V <sub>FB</sub> threshold voltage	T <sub>A</sub> = 25°C, V <sub>O</sub> = 1.05 V	757	765	773	mV
		T <sub>A</sub> = 0°C to 85°C, V <sub>O</sub> = 1.05 V <sup>(1)</sup>	753		777	
		T <sub>A</sub> = -40°C to 85°C, V <sub>O</sub> = 1.05 V <sup>(1)</sup>	751		779	
I <sub>VFB</sub>	V <sub>FB</sub> input current	V <sub>FB</sub> = 0.8 V, T <sub>A</sub> = 25°C		0	±0.1	μA
R <sub>Dischg</sub>	V <sub>O</sub> discharge resistance	EN = 0 V, V <sub>O</sub> = 0.5 V, T <sub>A</sub> = 25°C		50	100	Ω
<b>V<sub>REG5</sub> OUTPUT</b>						
V <sub>VREG5</sub>	V <sub>REG5</sub> output voltage	T <sub>A</sub> = 25°C, 6.0 V < V <sub>CC</sub> < 18 V, 0 < I <sub>VREG5</sub> < 5 mA	5.3	5.5	5.7	V
V <sub>LN5</sub>	Line regulation	6.0 V < V <sub>CC</sub> < 18 V, I <sub>VREG5</sub> = 5 mA			20	mV
V <sub>LD5</sub>	Load regulation	0 mA < I <sub>VREG5</sub> < 5 mA			100	mV
I <sub>VREG5</sub>	Output current	V <sub>CC</sub> = 6 V, V <sub>REG5</sub> = 4.0 V, T <sub>A</sub> = 25°C		70		mA
<b>MOSFET</b>						
R <sub>dsonh</sub>	High side switch resistance	25°C, V <sub>BST</sub> - SW1, SW2 = 5.5 V		120		mΩ
R <sub>dsonl</sub>	Low side switch resistance	25°C		70		mΩ
<b>CURRENT LIMIT</b>						
I <sub>ocl</sub>	Current limit	T <sub>A</sub> = -40°C to 85°C <sup>(1)</sup>	3.5	4.1	5.5	A
<b>THERMAL SHUTDOWN</b>						
T <sub>SDN</sub>	Thermal shutdown threshold	Shutdown temperature <sup>(1)</sup>		150		°C
		Hysteresis <sup>(1)</sup>		25		

(1) Not production tested.

**ELECTRICAL CHARACTERISTICS (continued)**over operating free-air temperature range,  $V_{CC}$ ,  $V_{IN} = 12\text{ V}$  (unless otherwise noted)

PARAMETER		TEST CONDITIONS	MIN	TYP	MAX	UNIT
<b>ON-TIME TIMER CONTROL</b>						
$T_{ON}$	On time	$V_{IN} = 12\text{ V}$ , $V_O = 1.05\text{ V}$		145		ns
$T_{OFF(MIN)}$	Minimum off time	$T_A = 25^\circ\text{C}$ , $V_{FB} = 0.7\text{ V}$		260		ns
<b>SOFT START</b>						
$I_{SSC}$	SS charge current	$V_{SS} = 0\text{ V}$	1.4	2.0	2.6	$\mu\text{A}$
$I_{SSD}$	SS discharge current	$V_{SS} = 0.5\text{ V}$	0.1	0.2		mA
<b>POWER GOOD</b>						
$V_{THPG}$	PG threshold	$V_{FB}$ rising (good)	85	90	95	%
		$V_{FB}$ falling (fault)		85		
$I_{PG}$	PG sink current	$PG = 0.5\text{ V}$	2.5	5		mA
<b>OUTPUT UNDERVOLTAGE AND OVERVOLTAGE PROTECTION</b>						
$V_{OVP}$	Output OVP trip threshold	OVP detect	115	120	125	%
$T_{OVPDEL}$	Output OVP prop delay			5		$\mu\text{s}$
$V_{UVP}$	Output UVP trip threshold	UVP detect	65	70	75	%
		Hysteresis		10		
$T_{UVPDEL}$	Output UVP delay			0.25		ms
$T_{UVPEN}$	Output UVP enable delay	Relative to soft-start time		x 1.7		
<b>UVLO</b>						
$V_{UVLO}$	UVLO threshold	Wake up $V_{REG5}$ voltage	3.45	3.70	3.95	V
		Hysteresis $V_{REG5}$ voltage	0.15	0.25	0.35	

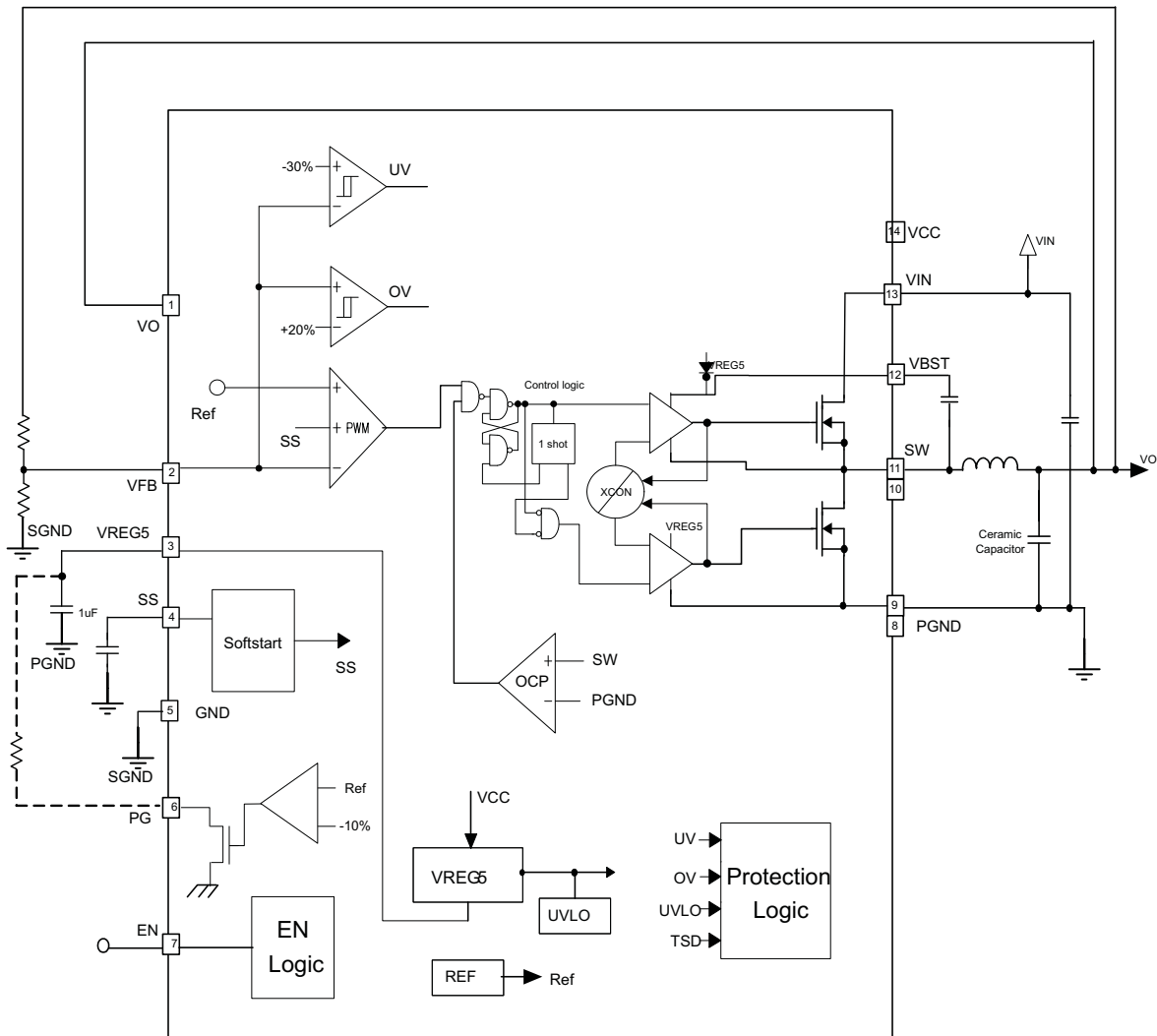
## DEVICE INFORMATION



## TERMINAL FUNCTIONS

TERMINAL		DESCRIPTION
NAME	NO.	
VO	1	Connect to output of converter. This terminal is used for On-Time Adjustment.
VFB	2	Converter feedback input. Connect with feedback resistor divider.
VREG5	3	5.5 V power supply output. A capacitor (typical 1µF) should be connected to GND.
SS	4	Soft-start control. A external capacitor should be connected to GND.
GND	5	Signal ground pin
PG	6	Open drain power good output
EN	7	Enable control input
PGND1, PGND2	8, 9	Ground returns for low-side MOSFET. Also serve as inputs of current comparators. Connect PGND and GND strongly together near the IC.
SW1, SW2	10, 11	Switch node connection between high-side NFET and low-side NFET. Also serve as inputs to current comparators.
VBST	12	Supply input for high-side NFET gate driver (boost terminal). Connect capacitor from this pin to respective SW1, SW2 terminals. An internal PN diode is connected between VREG5 to VBST pin.
VIN	13	Power input and connected to high side NFET drain
VCC	14	Supply input for 5 V internal linear regulator for the control circuitry
PowerPAD™	Back side	Thermal pad of the package. Must be soldered to achieve appropriate dissipation. Should be connected to PGND.

Functional Block Diagram



## OVERVIEW

The TPS54325 is a 3-A synchronous step-down (buck) converter with two integrated N-channel MOSFETs. It operates using D-CAP2™ mode control. The fast transient response of D-CAP2™ control reduces the output capacitance required to meet a specific level of performance. Proprietary internal circuitry allows the use of low ESR output capacitors including ceramic and special polymer types.

## DETAILED DESCRIPTION

### PWM Operation

The main control loop of the TPS54325 is an adaptive on-time pulse width modulation (PWM) controller that supports a proprietary D-CAP2™ mode control. D-CAP2™ mode control combines constant on-time control with an internal compensation circuit for pseudo-fixed frequency and low external component count configuration with both low ESR and ceramic output capacitors. It is stable even with virtually no ripple at the output.

At the beginning of each cycle, the high-side MOSFET is turned on. This MOSFET is turned off after internal one shot timer expires. This one shot timer is set by the converter input voltage,  $V_{IN}$ , and the output voltage,  $V_O$ , to maintain a pseudo-fixed frequency over the input voltage range, hence it is called adaptive on-time control. The one-shot timer is reset and the high-side MOSFET is turned on again when the feedback voltage falls below the reference voltage. An internal ramp is added to the reference voltage to simulate output ripple, eliminating the need for ESR induced output ripple from D-CAP2™ mode control.

### PWM Frequency and Adaptive On-Time Control

TPS54325 uses an adaptive on-time control scheme and does not have a dedicated on board oscillator. The TPS54325 runs with a pseudo-constant frequency of 700 kHz by using the input voltage and output voltage to set the on-time one-shot timer. The on-time is inversely proportional to the input voltage and proportional to the output voltage, therefore, when the duty ratio is  $V_{OUT}/V_{IN}$ , the frequency is constant.

### Soft Start and Pre-Biased Soft Start

The TPS54325 has an adjustable soft start. When the EN pin becomes high, 2.0- $\mu$ A current begins charging the capacitor which is connected from the SS pin to GND. Smooth control of the output voltage is maintained during start up. The equation for the slow start time is shown in [Equation 1](#). VFB voltage is 0.765 V and SS pin source current is 2  $\mu$ A.

$$T_{SS}(ms) = \frac{C6(nF) \cdot V_{ref}}{I_{SS}(\mu A)} = \frac{C6(nF) \cdot 0.765}{2} \quad (1)$$

The TPS54325 contains a unique circuit to prevent current from being pulled from the output during startup in the condition the output is pre-biased. When the soft-start commands a voltage higher than the pre-bias level (internal soft start becomes greater than feedback voltage ( $V_{FB}$ ), the controller slowly activates synchronous rectification by starting the first low side FET gate driver pulses with a narrow on-time. It then increments that on-time on a cycle-by-cycle basis until it coincides with the time dictated by  $(1-D)$ , where D is the duty cycle of the converter. This scheme prevents the initial sinking of the pre-bias output, and ensure that the out voltage ( $V_O$ ) starts and ramps up smoothly into regulation and the control loop is given time to transition from pre-biased start-up to normal mode operation.

### Power Good

The TPS54325 has power-good output. The power-good function is activated after soft start has finished. If the output voltage becomes within -10% of the target value, internal comparators detect power good state and the power good signal becomes high.  $R_{PG}$  resistor value, which is connected between PG and VREG5, is required from 20 k $\Omega$  to 150 k $\Omega$ . If the feedback voltage goes under 15% of the target value, the power good signal becomes low after 10  $\mu$ s internal delay.

### Output Discharge Control

The TPS54325 discharges the output when EN is low, or the controller is turned off by the protection functions (OVP, UVP, UVLO and thermal shutdown). The device discharges outputs using an internal 50- $\Omega$  MOSFET which is connected to  $V_O$  and PGND. The internal low-side MOSFET is not turned on during the output discharge operation to avoid the possibility of causing negative voltage at the output.

### Current Protection

The output over-current protection (OCP) is implemented using a cycle-by-cycle valley detect control circuit. The switch current is monitored by measuring the low-side FET switch voltage between the SW pin and GND. This voltage is proportional to the switch current. To improve accuracy, the voltage sensing is temperature compensated.

During the on time of the high-side FET switch, the switch current increases at a linear rate determined by  $V_{IN}$ ,  $V_{OUT}$ , the on-time and the output inductor value. During the on time of the low-side FET switch, this current decreases linearly. The average value of the switch current is the load current  $I_{out}$ . If the measured voltage is above the voltage proportional to the current limit, Then , the device constantly monitors the low-side FET switch voltage, which is proportional to the switch current, during the low-side on-time.

The converter maintains the low-side switch on until the measured voltage is below the voltage corresponding to the current limit at which time the switching cycle is terminated and a new switching cycle begins. In subsequent switching cycles, the on-time is set to a fixed value and the current is monitored in the same manner.

There are some important considerations for this type of over-current protection. The load current one half of the peak-to-peak inductor current higher than the over-current threshold. Also when the current is being limited, the output voltage tends to fall as the demanded load current may be higher than the current available from the converter. This may cause the output under-voltage protection circuit to be activated. When the over current condition is removed, the output voltage will return to the regulated value. This protection is non-latching.

### Over/Under Voltage Protection

The TPS54325 monitors a resistor divided feedback voltage to detect over and under voltage. When the feedback voltage becomes higher than 120% of the target voltage, the OVP comparator output goes high and the circuit latches the high-side MOSFET driver turns off and the low-side MOSFET turns on.

When the feedback voltage becomes lower than 70% of the target voltage, the UVP comparator output goes high and an internal UVP delay counter begins. After 250  $\mu$ s, the device latches off both internal top and bottom MOSFET. This function is enabled approximately 1.7 x soft-start time.

### UVLO Protection

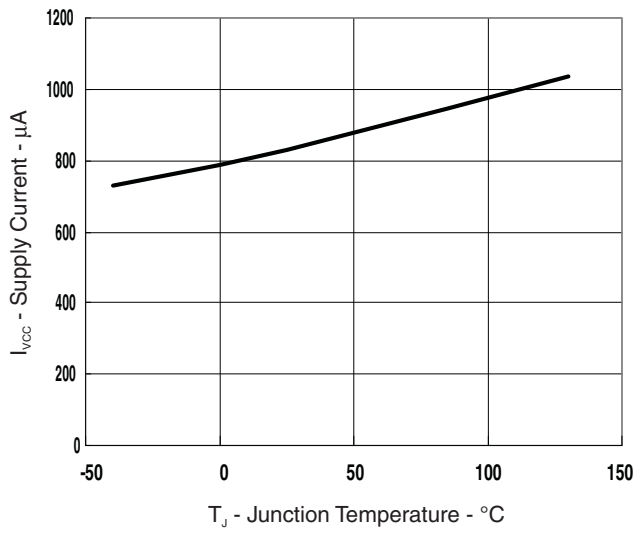
The TPS54325 has under voltage lock out protection (UVLO) that monitors the voltage of  $V_{REG5}$  pin. When the  $V_{REG5}$  voltage is lower than UVLO threshold voltage, the TPS54325 is shut off. This is non-latch protection.

### Thermal Shutdown

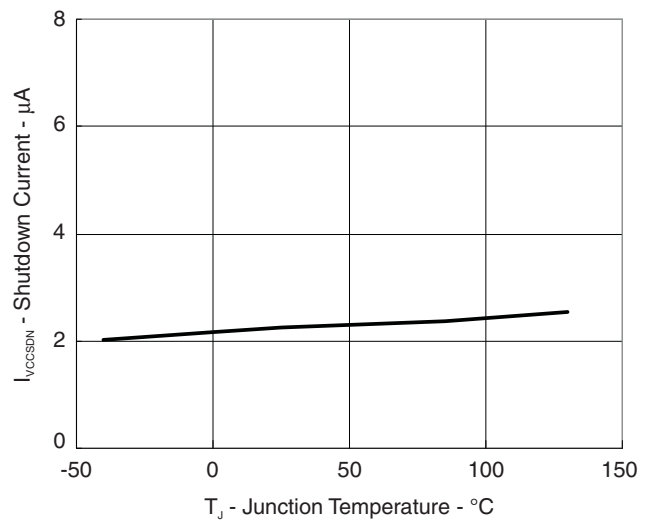
The TPS54325 monitors the temperature of itself. If the temperature exceeds the threshold value (typically 150°C), the device is shut off. This is non-latch protection.



**TYPICAL CHARACTERISTICS**

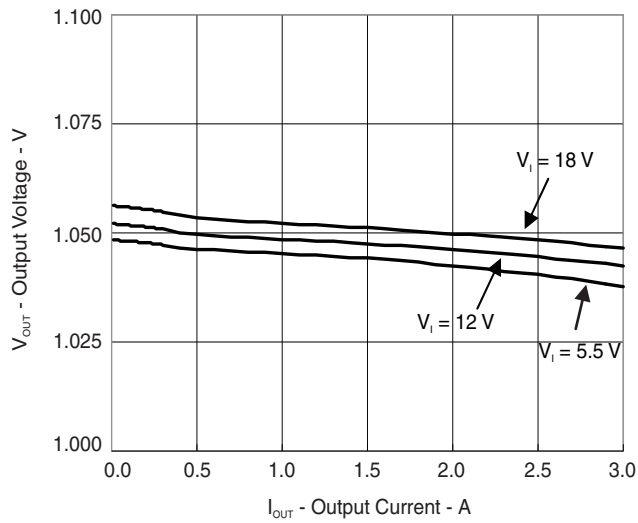


**Figure 1. V<sub>CC</sub> TEMPERATURE vs. JUNCTION TEMPERATURE**

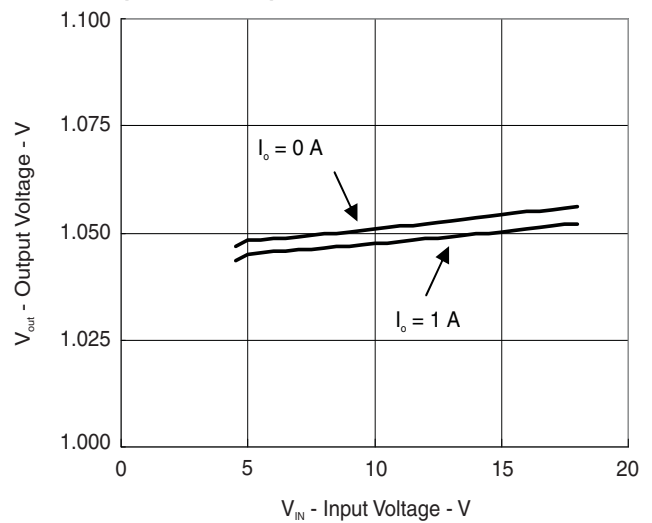


**Figure 2. V<sub>CC</sub> SHUTDOWN CURRENT vs. JUNCTION TEMPERATURE**

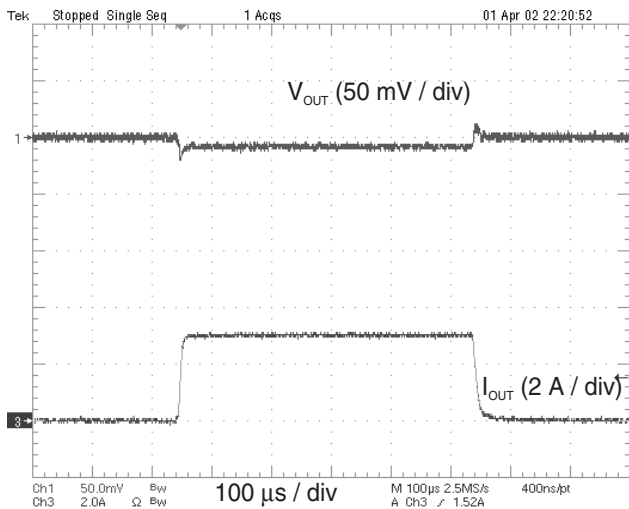
**TYPICAL CHARACTERISTICS (continued)**



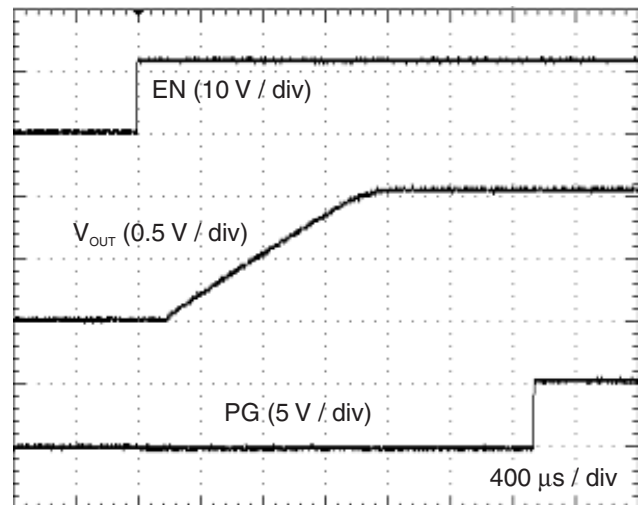
**Figure 3. 1.05-V OUTPUT VOLTAGE vs. OUTPUT CURRENT**



**Figure 4. 1.05-V OUTPUT VOLTAGE vs. INPUT VOLTAGE**



**Figure 5. 1.05-V, 0-A TO 3-A LOAD TRANSIENT RESPONSE**



**Figure 6. START-UP WAVE FORM**

TYPICAL CHARACTERISTICS (continued)

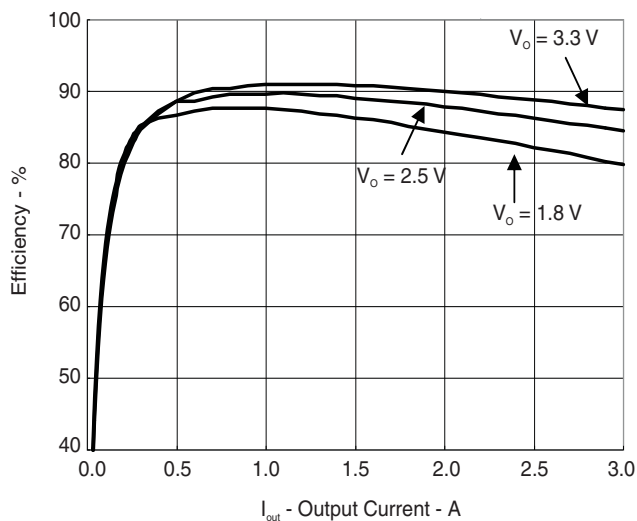


Figure 7. EFFICIENCY vs. OUTPUT CURRENT (V<sub>IN</sub> = 12 V)

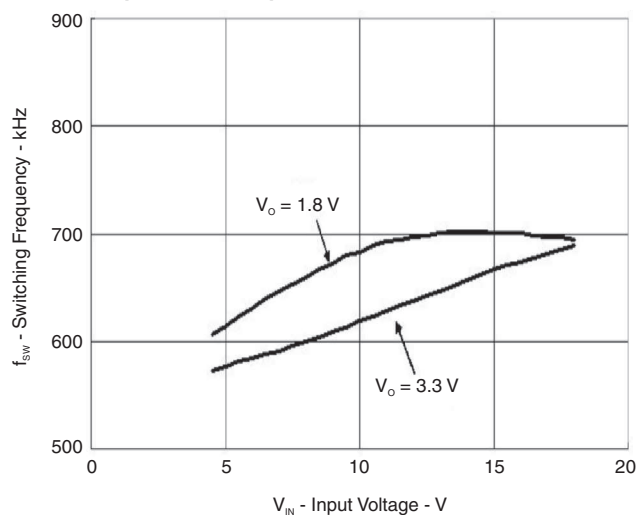


Figure 8. SWITCHING FREQUENCY vs. INPUT VOLTAGE (I<sub>O</sub> = 1 A)

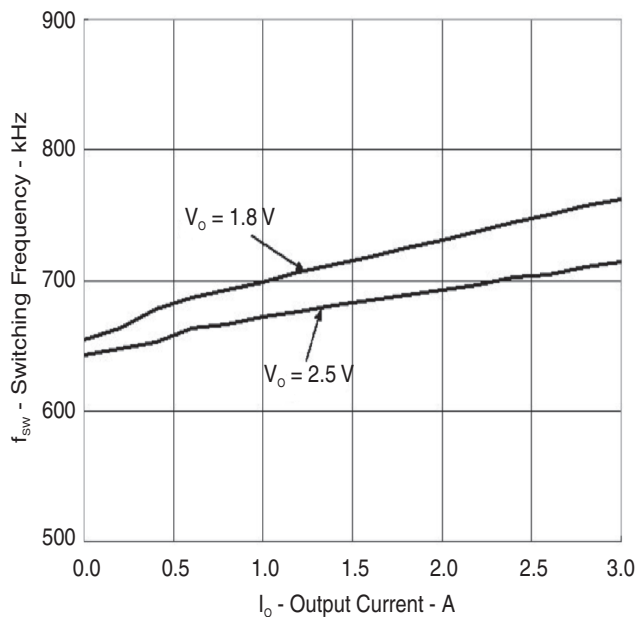


Figure 9. SWITCHING FREQUENCY vs. OUTPUT CURRENT

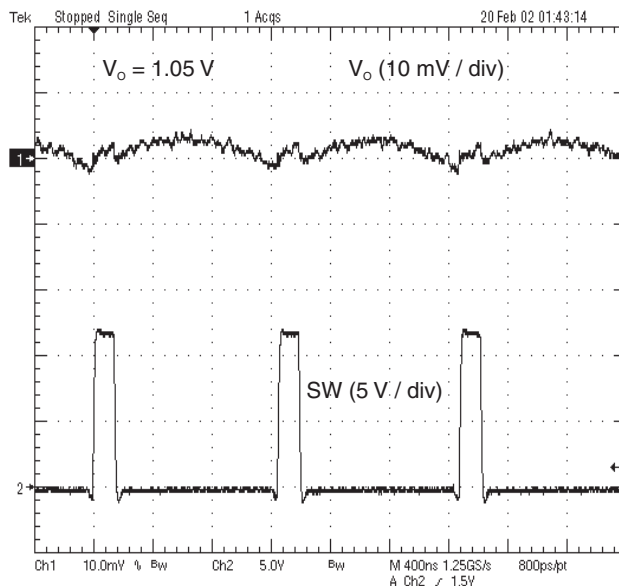


Figure 10. VOLTAGE RIPPLE AT OUTPUT

### TYPICAL CHARACTERISTICS (continued)

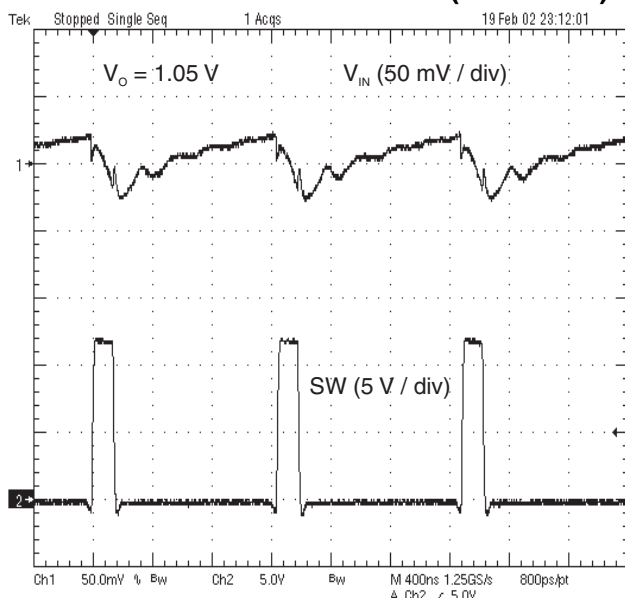


Figure 11. VOLTAGE RIPPLE AT INPUT

## DESIGN GUIDE

### Step By Step Design Procedure

To begin the design process, you must know a few application parameters:

- Input voltage range
- Output voltage
- Output current
- Output voltage ripple
- Input voltage ripple

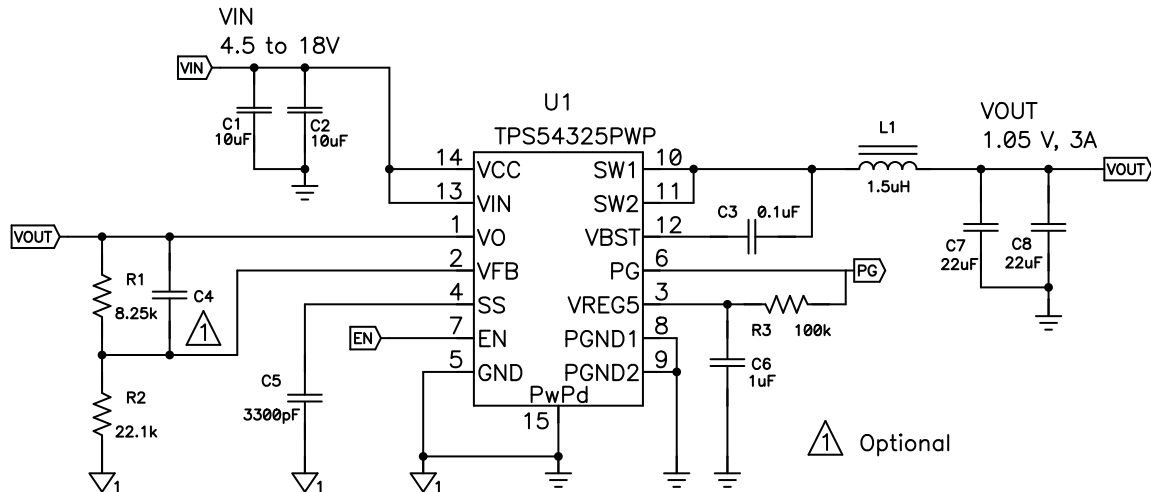


Figure 12. Schematic Diagram for this Design Example

### Output Voltage Resistors Selection

The output voltage is set with a resistor divider from the output node to the VFB pin. It is recommended to use 1% tolerance or better divider resistors. Start by using Equation 2 and Equation 3 to calculate  $V_{OUT}$ .

To improve efficiency at very light loads consider using larger value resistors, too high of resistance will be more susceptible to noise and voltage errors from the VFB input current will be more noticeable.

For output voltage from 0.76 V to 2.5 V:

$$V_{OUT} = 0.765 \cdot \left(1 + \frac{R1}{R2}\right) \quad (2)$$

For output voltage over 2.5 V:

$$V_{OUT} = (0.763 + 0.0017 \cdot V_{OUT}) \cdot \left(1 + \frac{R1}{R2}\right) \quad (3)$$

Where:

$V_{OUT\_SET}$  = Target  $V_{OUT}$  voltage

### Output Filter Selection

The output filter used with the TPS54325 is an LC circuit. This LC filter has double pole at:

$$F_P = \frac{1}{2\pi \sqrt{L_{OUT} \times C_{OUT}}} \quad (4)$$

At low frequencies, the overall loop gain is set by the output set-point resistor divider network and the internal gain of the TPS54325. The low frequency phase is 180 degrees. At the output filter pole frequency, the gain rolls off at a -40 dB per decade rate and the phase drops rapidly. D-CAP2 introduces a high frequency zero that reduces the gain roll off to -20 dB per decade and increases the phase to 90 degrees one decade above the zero frequency. The inductor and capacitor selected for the output filter must be selected so that the double pole of Equation 4 is located below the high frequency zero but close enough that the phase boost provided by the high frequency zero provides adequate phase margin for a stable circuit. To meet this requirement use the values recommended in Table 1.

**Table 1. Recommended Component Values**

Output Voltage (V)	R1 (kΩ)	R2 (kΩ)	C4 (pF) <sup>(1)</sup>	L1 (μH)	C8 + C9 (μF)
1	6.81	22.1		1.5	22 - 68
1.05	8.25	22.1		1.5	22 - 68
1.2	12.7	22.1		1.5	22 - 68
1.8	30.1	22.1	10 - 22	2.2	22 - 68
2.5	49.9	22.1	10 - 22	2.2	22 - 68
3.3	73.2	22.1	10 - 22	2.2	22 - 68
5	121	22.1	10 - 22	3.3	22 - 68

(1) Optional

For higher output voltages at or above 1.8 V, additional phase boost can be achieved by adding a feed forward capacitor (C4) in parallel with R1.

The inductor peak-to-peak ripple current, peak current and RMS current are calculated using Equation 5, Equation 6 and Equation 7. The inductor saturation current rating must be greater than the calculated peak current and the RMS or heating current rating must be greater than the calculated RMS current.

Use 700 kHz for  $f_{SW}$ . Make sure the chosen inductor is rated for the peak current of Equation 6 and the RMS current of Equation 7.

$$I_{pp} - p = \frac{V_{OUT}}{V_{IN(max)}} \cdot \frac{V_{IN(max)} - V_{OUT}}{L_O \cdot f_{SW}} \quad (5)$$

$$I_{peak} = I_O + \frac{I_{pp} - p}{2} \quad (6)$$

$$I_{Lo(RMS)} = \sqrt{I_O^2 + \frac{1}{12} I_{pp} - p^2} \quad (7)$$

For this design example, the calculated peak current is 3.47 A and the calculated RMS current is 3.01 A. The inductor used is a TDK SPM6530-1R5M100 with a peak current rating of 11.5 A and an RMS current rating of 11 A.

The capacitor value and ESR determines the amount of output voltage ripple. The TPS54325 is intended for use with ceramic or other low ESR capacitors. Recommended values range from 22 μF to 68 μF. Use Equation 8 to determine the required RMS current rating for the output capacitor.

$$I_{CO(RMS)} = \frac{V_{OUT} \cdot (V_{IN} - V_{OUT})}{\sqrt{12} \cdot V_{IN} \cdot L_O \cdot f_{SW}} \quad (8)$$

For this design two TDK C3216X5R0J226M 22-μF output capacitors are used. The typical ESR is 2 mΩ each. The calculated RMS current is 0.271 A and each output capacitor is rated for 4 A.

### Input Capacitor Selection

The TPS54325 requires an input decoupling capacitor and a bulk capacitor is needed depending on the application. A ceramic capacitor over 10-mF is recommended for the decoupling capacitor. An additional 0.1-μF capacitor from pin 14 to ground is recommended to improve the stability of the over-current limit function. The capacitor voltage rating needs to be greater than the maximum input voltage.

### Bootstrap Capacitor Selection

A 0.1- $\mu$ F ceramic capacitor must be connected between the VREG5 to GND pin for proper operation. It is recommended to use a ceramic capacitor.

### THERMAL INFORMATION

This PowerPAD™ package incorporates an exposed thermal pad that is designed to be connected to an external heatsink. The thermal pad must be soldered directly to the printed board (PCB). After soldering, the PCB can be used as a heatsink. In addition, through the use of thermal vias, the thermal pad can be attached directly to the appropriate copper plane shown in the electrical schematic for the device, or alternatively, can be attached to a special heatsink structure designed into the PCB. This design optimizes the heat transfer from the integrated circuit (IC).

For additional information on the PowerPAD™ package and how to use the advantage of its heat dissipating abilities, refer to Technical Brief, PowerPAD™ Thermally Enhanced Package, Texas Instruments Literature No. [SLMA002](#) and Application Brief, PowerPAD™ Made Easy, Texas Instruments Literature No. [SLMA004](#).

The exposed thermal pad dimensions for this package are shown in the following illustration.

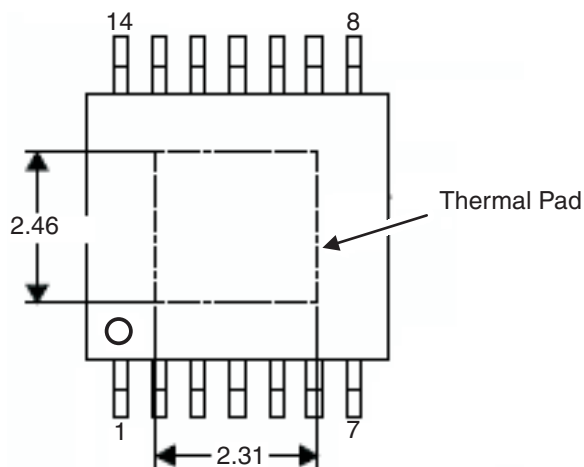
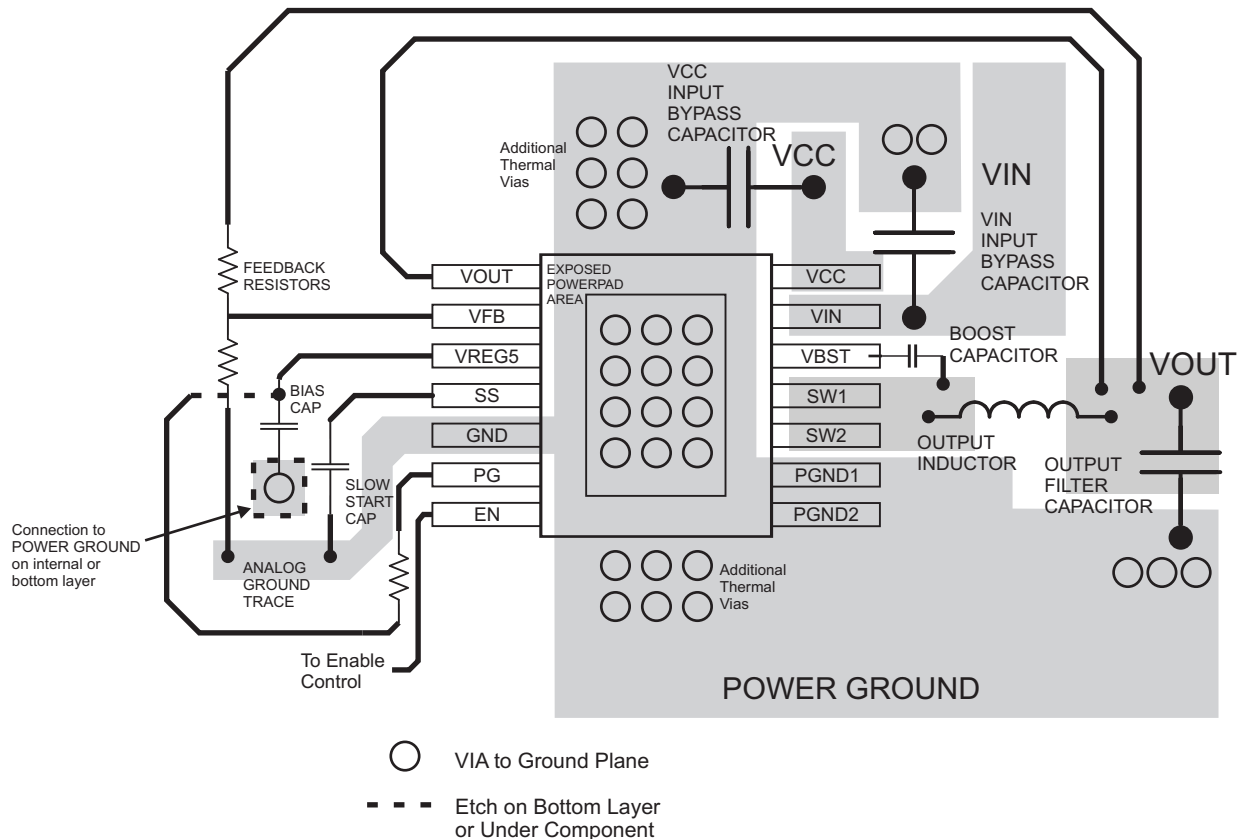


Figure 13. Thermal Pad Dimensions

**LAYOUT CONSIDERATIONS**

1. Keep the input switching current loop as small as possible.
2. Keep the SW node as physically small and short as possible to minimize parasitic capacitance and inductance and to minimize radiated emissions. Kelvin connections should be brought from the output to the feedback pin of the device.
3. Keep analog and non-switching components away from switching components.
4. Make a single point connection from the signal ground to power ground.
5. Do not allow switching current to flow under the device.
6. Keep the pattern lines for VIN and PGND broad.
7. Exposed pad of device must be connected to PGND with solder.
8. VREG5 capacitor should be placed near the device, and connected PGND.
9. Output capacitor should be connected to a broad pattern of the PGND.
10. Voltage feedback loop should be as short as possible, and preferably with ground shield.
11. Lower resistor of the voltage divider which is connected to the VFB pin should be tied to SGND.
12. Providing sufficient via is preferable for VIN, SW and PGND connection.
13. PCB pattern for VIN, SW, and PGND should be as broad as possible.
14. If VIN and VCC is shorted, VIN and VCC patterns need to be connected with broad pattern lines.
15. VIN Capacitor should be placed as near as possible to the device.



**Figure 14. PCB Layout**



## Revision History

The ambient temperature,  $T_A$ , for the current limit,  $I_{ocl}$ , was changed from 25°C to –40°C to 85°C and 3.5 A was added at min range.

$V_{IN} = 12\text{ V}$  was specified for Figure 7. Efficiency vs. Output Current.

Changes from Revision B (March 2011) to Revision C	Page
• Changed EN high-level input voltage from min of 2.0 V to min of 1.6 V .....	3
• Changed EN low-level input voltage from max of 0.48 V to max of 0.4 V .....	3

---

**PACKAGING INFORMATION**

Orderable Device	Status <sup>(1)</sup>	Package Type	Package Drawing	Pins	Package Qty	Eco Plan <sup>(2)</sup>	Lead/ Ball Finish	MSL Peak Temp <sup>(3)</sup>	Samples (Requires Login)
TPS54325PWP	ACTIVE	HTSSOP	PWP	14	90	Green (RoHS & no Sb/Br)	CU NIPDAU	Level-2-260C-1 YEAR	
TPS54325PWPR	ACTIVE	HTSSOP	PWP	14	2000	Green (RoHS & no Sb/Br)	CU NIPDAU	Level-2-260C-1 YEAR	

<sup>(1)</sup> The marketing status values are defined as follows:

**ACTIVE:** Product device recommended for new designs.

**LIFEBUY:** TI has announced that the device will be discontinued, and a lifetime-buy period is in effect.

**NRND:** Not recommended for new designs. Device is in production to support existing customers, but TI does not recommend using this part in a new design.

**PREVIEW:** Device has been announced but is not in production. Samples may or may not be available.

**OBSOLETE:** TI has discontinued the production of the device.

<sup>(2)</sup> Eco Plan - The planned eco-friendly classification: Pb-Free (RoHS), Pb-Free (RoHS Exempt), or Green (RoHS & no Sb/Br) - please check <http://www.ti.com/productcontent> for the latest availability information and additional product content details.

**TBD:** The Pb-Free/Green conversion plan has not been defined.

**Pb-Free (RoHS):** TI's terms "Lead-Free" or "Pb-Free" mean semiconductor products that are compatible with the current RoHS requirements for all 6 substances, including the requirement that lead not exceed 0.1% by weight in homogeneous materials. Where designed to be soldered at high temperatures, TI Pb-Free products are suitable for use in specified lead-free processes.

**Pb-Free (RoHS Exempt):** This component has a RoHS exemption for either 1) lead-based flip-chip solder bumps used between the die and package, or 2) lead-based die adhesive used between the die and leadframe. The component is otherwise considered Pb-Free (RoHS compatible) as defined above.

**Green (RoHS & no Sb/Br):** TI defines "Green" to mean Pb-Free (RoHS compatible), and free of Bromine (Br) and Antimony (Sb) based flame retardants (Br or Sb do not exceed 0.1% by weight in homogeneous material)

<sup>(3)</sup> MSL, Peak Temp. -- The Moisture Sensitivity Level rating according to the JEDEC industry standard classifications, and peak solder temperature.

**Important Information and Disclaimer:** The information provided on this page represents TI's knowledge and belief as of the date that it is provided. TI bases its knowledge and belief on information provided by third parties, and makes no representation or warranty as to the accuracy of such information. Efforts are underway to better integrate information from third parties. TI has taken and continues to take reasonable steps to provide representative and accurate information but may not have conducted destructive testing or chemical analysis on incoming materials and chemicals. TI and TI suppliers consider certain information to be proprietary, and thus CAS numbers and other limited information may not be available for release.

In no event shall TI's liability arising out of such information exceed the total purchase price of the TI part(s) at issue in this document sold by TI to Customer on an annual basis.

**TAPE AND REEL INFORMATION**
**REEL DIMENSIONS**

**TAPE DIMENSIONS**


A0	Dimension designed to accommodate the component width
B0	Dimension designed to accommodate the component length
K0	Dimension designed to accommodate the component thickness
W	Overall width of the carrier tape
P1	Pitch between successive cavity centers

**TAPE AND REEL INFORMATION**

\*All dimensions are nominal

Device	Package Type	Package Drawing	Pins	SPQ	Reel Diameter (mm)	Reel Width W1 (mm)	A0 (mm)	B0 (mm)	K0 (mm)	P1 (mm)	W (mm)	Pin1 Quadrant
TPS54325PWPR	HTSSOP	PWP	14	2000	330.0	12.4	6.9	5.6	1.6	8.0	12.0	Q1
TPS54325PWPR	HTSSOP	PWP	14	2000	330.0	12.4	6.9	5.6	1.6	8.0	12.0	Q1

**TAPE AND REEL BOX DIMENSIONS**



\*All dimensions are nominal

Device	Package Type	Package Drawing	Pins	SPQ	Length (mm)	Width (mm)	Height (mm)
TPS54325PWPR	HTSSOP	PWP	14	2000	367.0	367.0	35.0
TPS54325PWPR	HTSSOP	PWP	14	2000	367.0	367.0	35.0

PWP (R-PDSO-G14)

PowerPAD™ PLASTIC SMALL OUTLINE



4073225-2/1 05/11

- NOTES:
- A. All linear dimensions are in millimeters.
  - B. This drawing is subject to change without notice.
  - C. Body dimensions do not include mold flash or protrusions. Mold flash and protrusion shall not exceed 0.15 per side.
  - D. This package is designed to be soldered to a thermal pad on the board. Refer to Technical Brief, PowerPad Thermally Enhanced Package, Texas Instruments Literature No. SLMA002 for information regarding recommended board layout. This document is available at [www.ti.com](http://www.ti.com) <<http://www.ti.com>>.
  - E. See the additional figure in the Product Data Sheet for details regarding the exposed thermal pad features and dimensions.
  - E. Falls within JEDEC MO-153

PowerPAD is a trademark of Texas Instruments.

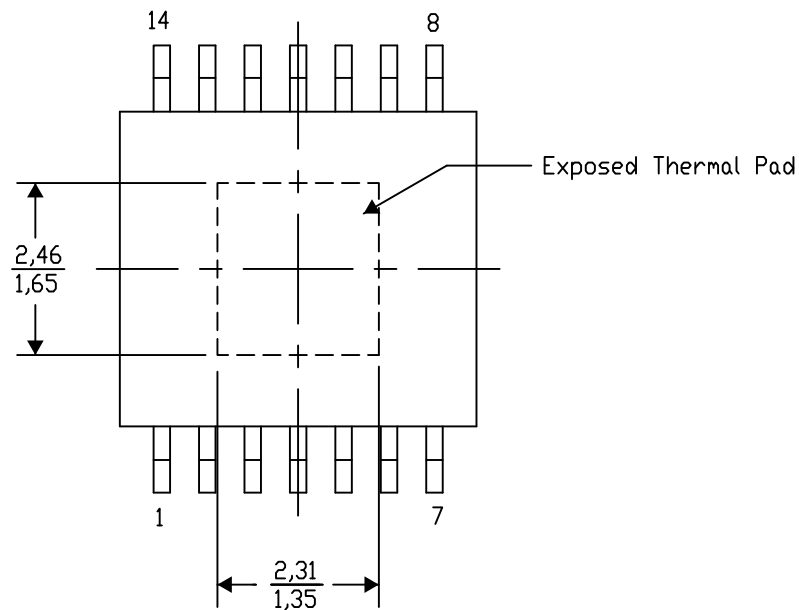
## PWP (R-PDSO-G14) PowerPAD™ SMALL PLASTIC OUTLINE

### THERMAL INFORMATION

This PowerPAD™ package incorporates an exposed thermal pad that is designed to be attached to a printed circuit board (PCB). The thermal pad must be soldered directly to the PCB. After soldering, the PCB can be used as a heatsink. In addition, through the use of thermal vias, the thermal pad can be attached directly to the appropriate copper plane shown in the electrical schematic for the device, or alternatively, can be attached to a special heatsink structure designed into the PCB. This design optimizes the heat transfer from the integrated circuit (IC).

For additional information on the PowerPAD package and how to take advantage of its heat dissipating abilities, refer to Technical Brief, PowerPAD Thermally Enhanced Package, Texas Instruments Literature No. SLMA002 and Application Brief, PowerPAD Made Easy, Texas Instruments Literature No. SLMA004. Both documents are available at [www.ti.com](http://www.ti.com).

The exposed thermal pad dimensions for this package are shown in the following illustration.



Top View

Exposed Thermal Pad Dimensions

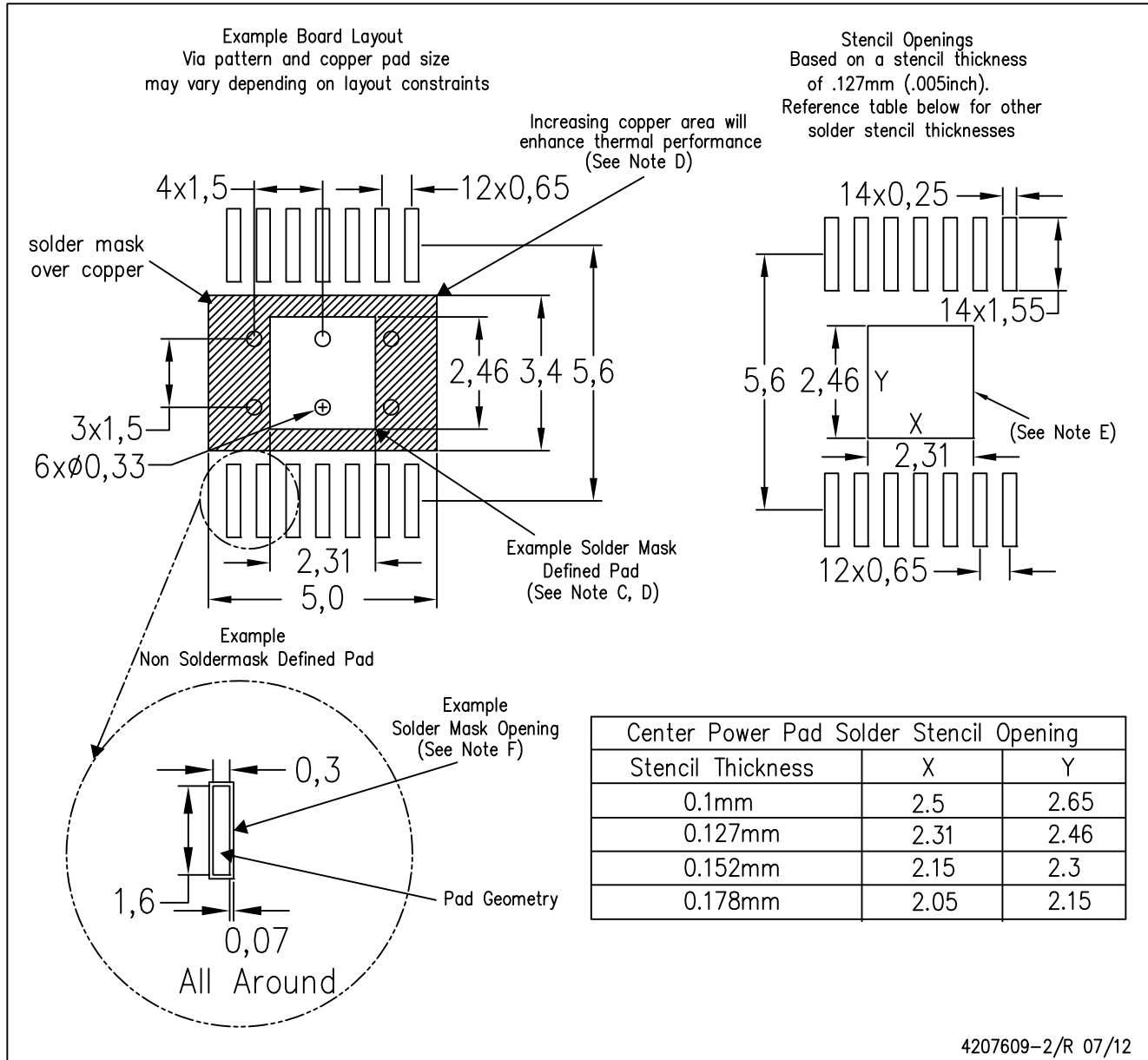
4206332-2/AC 07/12

NOTE: A. All linear dimensions are in millimeters

PowerPAD is a trademark of Texas Instruments

PWP (R-PDSO-G14)

PowerPAD™ PLASTIC SMALL OUTLINE



- NOTES:
- A. All linear dimensions are in millimeters.
  - B. This drawing is subject to change without notice.
  - C. Customers should place a note on the circuit board fabrication drawing not to alter the center solder mask defined pad.
  - D. This package is designed to be soldered to a thermal pad on the board. Refer to Technical Brief, PowerPAD Thermally Enhanced Package, Texas Instruments Literature No. SLMA002, SLMA004, and also the Product Data Sheets for specific thermal information, via requirements, and recommended board layout. These documents are available at [www.ti.com](http://www.ti.com) <<http://www.ti.com>>. Publication IPC-7351 is recommended for alternate designs.
  - E. Laser cutting apertures with trapezoidal walls and also rounding corners will offer better paste release. Customers should contact their board assembly site for stencil design recommendations. Example stencil design based on a 50% volumetric metal load solder paste. Refer to IPC-7525 for other stencil recommendations.
  - F. Customers should contact their board fabrication site for solder mask tolerances between and around signal pads.

## THERMAL PAD MECHANICAL DATA

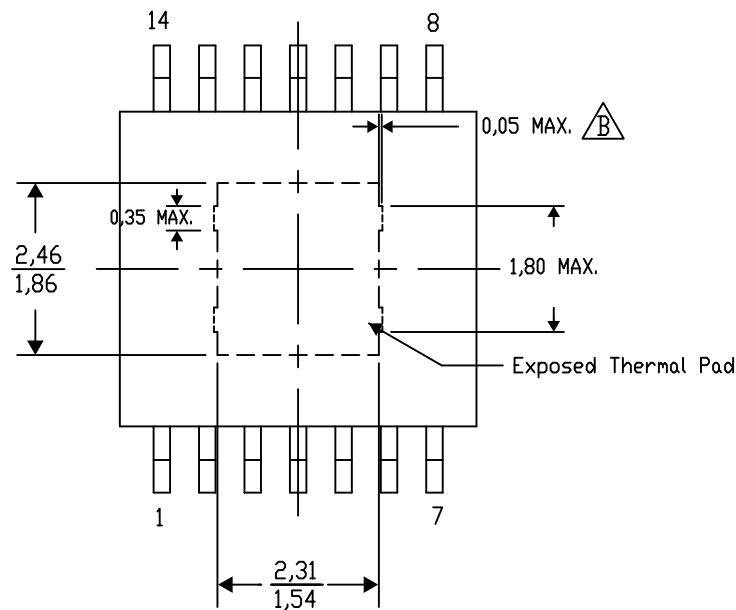
### PWP (R-PDSO-G14) PowerPAD™ SMALL PLASTIC OUTLINE

#### THERMAL INFORMATION

This PowerPAD™ package incorporates an exposed thermal pad that is designed to be attached to a printed circuit board (PCB). The thermal pad must be soldered directly to the PCB. After soldering, the PCB can be used as a heatsink. In addition, through the use of thermal vias, the thermal pad can be attached directly to the appropriate copper plane shown in the electrical schematic for the device, or alternatively, can be attached to a special heatsink structure designed into the PCB. This design optimizes the heat transfer from the integrated circuit (IC).

For additional information on the PowerPAD package and how to take advantage of its heat dissipating abilities, refer to Technical Brief, PowerPAD Thermally Enhanced Package, Texas Instruments Literature No. SLMA002 and Application Brief, PowerPAD Made Easy, Texas Instruments Literature No. SLMA004. Both documents are available at [www.ti.com](http://www.ti.com).

The exposed thermal pad dimensions for this package are shown in the following illustration.



Top View

Exposed Thermal Pad Dimensions

4206332-44/AC 07/12

NOTE: A. All linear dimensions are in millimeters

$\triangle B$  Exposed tie strap features may not be present.

PowerPAD is a trademark of Texas Instruments



## IMPORTANT NOTICE

Texas Instruments Incorporated and its subsidiaries (TI) reserve the right to make corrections, enhancements, improvements and other changes to its semiconductor products and services per JESD46, latest issue, and to discontinue any product or service per JESD48, latest issue. Buyers should obtain the latest relevant information before placing orders and should verify that such information is current and complete. All semiconductor products (also referred to herein as "components") are sold subject to TI's terms and conditions of sale supplied at the time of order acknowledgment.

TI warrants performance of its components to the specifications applicable at the time of sale, in accordance with the warranty in TI's terms and conditions of sale of semiconductor products. Testing and other quality control techniques are used to the extent TI deems necessary to support this warranty. Except where mandated by applicable law, testing of all parameters of each component is not necessarily performed.

TI assumes no liability for applications assistance or the design of Buyers' products. Buyers are responsible for their products and applications using TI components. To minimize the risks associated with Buyers' products and applications, Buyers should provide adequate design and operating safeguards.

TI does not warrant or represent that any license, either express or implied, is granted under any patent right, copyright, mask work right, or other intellectual property right relating to any combination, machine, or process in which TI components or services are used. Information published by TI regarding third-party products or services does not constitute a license to use such products or services or a warranty or endorsement thereof. Use of such information may require a license from a third party under the patents or other intellectual property of the third party, or a license from TI under the patents or other intellectual property of TI.

Reproduction of significant portions of TI information in TI data books or data sheets is permissible only if reproduction is without alteration and is accompanied by all associated warranties, conditions, limitations, and notices. TI is not responsible or liable for such altered documentation. Information of third parties may be subject to additional restrictions.

Resale of TI components or services with statements different from or beyond the parameters stated by TI for that component or service voids all express and any implied warranties for the associated TI component or service and is an unfair and deceptive business practice. TI is not responsible or liable for any such statements.

Buyer acknowledges and agrees that it is solely responsible for compliance with all legal, regulatory and safety-related requirements concerning its products, and any use of TI components in its applications, notwithstanding any applications-related information or support that may be provided by TI. Buyer represents and agrees that it has all the necessary expertise to create and implement safeguards which anticipate dangerous consequences of failures, monitor failures and their consequences, lessen the likelihood of failures that might cause harm and take appropriate remedial actions. Buyer will fully indemnify TI and its representatives against any damages arising out of the use of any TI components in safety-critical applications.

In some cases, TI components may be promoted specifically to facilitate safety-related applications. With such components, TI's goal is to help enable customers to design and create their own end-product solutions that meet applicable functional safety standards and requirements. Nonetheless, such components are subject to these terms.

No TI components are authorized for use in FDA Class III (or similar life-critical medical equipment) unless authorized officers of the parties have executed a special agreement specifically governing such use.

Only those TI components which TI has specifically designated as military grade or "enhanced plastic" are designed and intended for use in military/aerospace applications or environments. Buyer acknowledges and agrees that any military or aerospace use of TI components which have **not** been so designated is solely at the Buyer's risk, and that Buyer is solely responsible for compliance with all legal and regulatory requirements in connection with such use.

TI has specifically designated certain components which meet ISO/TS16949 requirements, mainly for automotive use. Components which have not been so designated are neither designed nor intended for automotive use; and TI will not be responsible for any failure of such components to meet such requirements.

### Products

Audio	<a href="http://www.ti.com/audio">www.ti.com/audio</a>
Amplifiers	<a href="http://amplifier.ti.com">amplifier.ti.com</a>
Data Converters	<a href="http://dataconverter.ti.com">dataconverter.ti.com</a>
DLP® Products	<a href="http://www.dlp.com">www.dlp.com</a>
DSP	<a href="http://dsp.ti.com">dsp.ti.com</a>
Clocks and Timers	<a href="http://www.ti.com/clocks">www.ti.com/clocks</a>
Interface	<a href="http://interface.ti.com">interface.ti.com</a>
Logic	<a href="http://logic.ti.com">logic.ti.com</a>
Power Mgmt	<a href="http://power.ti.com">power.ti.com</a>
Microcontrollers	<a href="http://microcontroller.ti.com">microcontroller.ti.com</a>
RFID	<a href="http://www.ti-rfid.com">www.ti-rfid.com</a>
OMAP Applications Processors	<a href="http://www.ti.com/omap">www.ti.com/omap</a>
Wireless Connectivity	<a href="http://www.ti.com/wirelessconnectivity">www.ti.com/wirelessconnectivity</a>

### Applications

Automotive and Transportation	<a href="http://www.ti.com/automotive">www.ti.com/automotive</a>
Communications and Telecom	<a href="http://www.ti.com/communications">www.ti.com/communications</a>
Computers and Peripherals	<a href="http://www.ti.com/computers">www.ti.com/computers</a>
Consumer Electronics	<a href="http://www.ti.com/consumer-apps">www.ti.com/consumer-apps</a>
Energy and Lighting	<a href="http://www.ti.com/energy">www.ti.com/energy</a>
Industrial	<a href="http://www.ti.com/industrial">www.ti.com/industrial</a>
Medical	<a href="http://www.ti.com/medical">www.ti.com/medical</a>
Security	<a href="http://www.ti.com/security">www.ti.com/security</a>
Space, Avionics and Defense	<a href="http://www.ti.com/space-avionics-defense">www.ti.com/space-avionics-defense</a>
Video and Imaging	<a href="http://www.ti.com/video">www.ti.com/video</a>

### TI E2E Community

[e2e.ti.com](http://e2e.ti.com)