

1.5A/4.1A Multiple LED Camera Flash Driver With I²C™ Compatible Interface

FEATURES

- **Four Operational Modes**
 - DC Light and Flashlight
 - Voltage Regulated Converter: 3.8V...5.7V
 - Standby: 2µA (typ.)
- **Storage Capacitor Friendly Solution**
- **Automatic V_F and ESR Calibration**
- **Power-Save Mode for Improved Efficiency at Low Output Power, Up to 95% Efficiency**
- **Output Voltage Remains Regulated When Input Voltage Exceeds Nominal Output Voltage**
- **I²C Compatible Interface up to 3.4Mbits/s**
- **Dual Wire Camera Module Interface**
- **Zero Latency Tx-Masking Input**
- **LED Temperature Monitoring**
- **Privacy Indicator LED Output**
- **Integrated LED Safety Timer**
- **GPIO/Flash Ready Output**
- **Total Solution Size of Less Than 25 mm² (<1mm height)**
- **Available in a 20-Pin NanoFree™ (CSP)**

APPLICATIONS

- **Single/Dual/Triple White LED Flashlight Supply for Cell Phones and Smart-Phones**
- **LED Based Xenon "Killer" Flashlight**

DESCRIPTION

The TPS6132x device is based on a high-frequency synchronous boost topology with constant current sinks to drive up to three white LEDs in parallel (445mA/890mA/445mA maximum flash current). **The extended high-current mode (HC_SEL) allows up to 1025mA/2050mA/1025mA flash current out of the storage capacitor.**

The high-capacity storage capacitor on the output of the boost regulator provides the high-peak flash LED current, thereby reducing the peak current demand from the battery to a minimum.

The 2-MHz switching frequency allows the use of small and low profile 2.2µH inductors. To optimize overall efficiency, the device operates with a 400mV LED feedback voltage.

The TPS6132x device not only operates as a regulated current source, but also as a standard voltage boost regulator. The device keeps the output voltage regulated even when the input voltage exceeds the nominal output voltage. The device enters power-save mode operation at light load currents to maintain high efficiency over the entire load current range.

To simplify DC light and flashlight synchronization with the camera module, the device offers a dedicated control interface (STRB0, STRB1) for zero latency LED turn-on time.

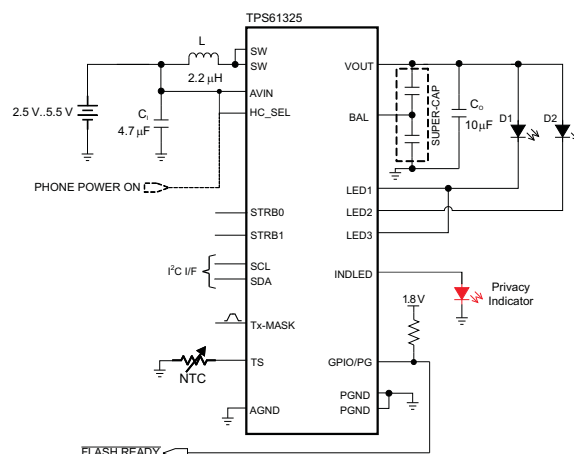

Figure 1. Typical Application



Please be aware that an important notice concerning availability, standard warranty, and use in critical applications of Texas Instruments semiconductor products and disclaimers thereto appears at the end of this data sheet.

NanoFree is a trademark of Texas Instruments.

I²C is a trademark of NXP Semiconductors.



This integrated circuit can be damaged by ESD. Texas Instruments recommends that all integrated circuits be handled with appropriate precautions. Failure to observe proper handling and installation procedures can cause damage.

ESD damage can range from subtle performance degradation to complete device failure. Precision integrated circuits may be more susceptible to damage because very small parametric changes could cause the device not to meet its published specifications.

AVAILABLE OPTIONS

PART NUMBER ⁽¹⁾	PACKAGE MARKING	PACKAGE	DEVICE SPECIFIC FEATURES ⁽²⁾
TPS61325YFF	TPS61325	CSP-20	Dual Wire Camera Module Interface (STRB0, STRB1) LED Temperature Monitoring Input (TS) Device I2C Address = 0x33
TPS61326YFF ⁽³⁾	TPS61326	CSP-20	Dual Wire Camera Module Interface (STRB0, STRB1) LED Temperature Monitoring Input (TS) Device I2C Address = 0x32

- (1) The YFF package is available in tape and reel. Add R suffix (TPS6132xYFFR) to order quantities of 3000 parts per reel, T suffix for 250 parts per reel.
- (2) For more details, refer to the section *Application Diagrams*.
- (3) Device status is Product Preview. Please contact TI for more details.

ABSOLUTE MAXIMUM RATINGS

over operating free-air temperature range (unless otherwise noted) ⁽¹⁾

		VALUE	UNIT
V _I	Voltage range on AVIN, VOUT, SW, LED1, LED2, LED3 ⁽²⁾	-0.3 to 7	V
	Voltage range on SCL, SDA, STRB0, STRB1, GPIO/PG ⁽²⁾	-0.3 to 7	V
	Voltage range on HC_SEL, Tx-MASK, TS, BAL ⁽²⁾	-0.3 to 7	V
	Current on GPIO/PG	±25	mA
	Power dissipation	Internally limited	
T _A ⁽³⁾	Operating ambient temperature range	-40 to 85	°C
T _{J (MAX)}	Maximum operating junction temperature	150	°C
T _{stg}	Storage temperature range	-65 to 150	°C
ESD rating ⁽⁴⁾	Human body model	2	kV
	Charge device model	500	V
	Machine model	100	V

- (1) Stresses beyond those listed under *absolute maximum ratings* may cause permanent damage to the device. These are stress ratings only, and functional operation of the device at these or any other conditions beyond those indicated under *recommended operating conditions* is not implied. Exposure to absolute–maximum–rated conditions for extended periods may affect device reliability.
- (2) All voltage values are with respect to network ground terminal.
- (3) In applications where high power dissipation and/or poor package thermal resistance is present, the maximum ambient temperature may have to be derated. Maximum ambient temperature [T_{A(max)}] is dependent on the maximum operating junction temperature [T_{J(max)}], the maximum power dissipation of the device in the application [P_{D(max)}], and the junction-to-ambient thermal resistance of the part/package in the application (θ_{JA}), as given by the following equation: T_{A(max)} = T_{J(max)} - (θ_{JA} × P_{D(max)})
- (4) The human body model is a 100-pF capacitor discharged through a 1.5-kΩ resistor into each pin. The machine model is a 200-pF capacitor discharged directly into each pin.

DISSIPATION RATINGS

PACKAGE	THERMAL RESISTANCE ⁽¹⁾ θ _{JA}	THERMAL RESISTANCE ⁽¹⁾ θ _{JB}	POWER RATING T _A = 25°C	DERATING FACTOR ABOVE ⁽²⁾ T _A = 25°C
YFF	71°C/W	21°C/W	1.4 W	14mW/°C

- (1) Simulated with high-K board
- (2) Maximum power dissipation is a function of T_{J(max)}, θ_{JA} and T_A. The maximum allowable power dissipation at any allowable ambient temperature is P_D = (T_{J(max)} - T_A) / θ_{JA}.

ELECTRICAL CHARACTERISTICS

Unless otherwise noted the specification applies for $V_{IN} = 3.6V$ over an operating junction temp. $-40^{\circ}C \leq T_J \leq 125^{\circ}C$; Circuit of Parameter Measurement Information section (unless otherwise noted). Typical values are for $T_J = 25^{\circ}C$.

PARAMETER		TEST CONDITIONS	MIN	TYP	MAX	UNIT
SUPPLY CURRENT						
V_{IN}	Input voltage range		2.5		5.5	V
I_Q	Operating quiescent current into AVIN	$I_{OUT} = 0$ mA, device not switching $-40^{\circ}C \leq T_J \leq +85^{\circ}C$		590	700	μA
		$I_{OUT(DC)} = 0$ mA, PWM operation $V_{OUT} = 4.95V$, voltage regulation mode		11.3		mA
I_{SD}	Shutdown current	HC_SEL = 0, $-40^{\circ}C \leq T_J \leq +85^{\circ}C$		1	5	μA
I_{STBY}	Standby current	HC_SEL = 1, storage capacitor balanced $-40^{\circ}C \leq T_J \leq +85^{\circ}C$		2	12	μA
	Pre-charge current	$0V \leq V_{OUT} \leq 3.3V$, device in pre-charge mode $-40^{\circ}C \leq T_J \leq +85^{\circ}C$	80	180	220	mA
	Pre-charge termination threshold	V_{OUT} rising, $-40^{\circ}C \leq T_J \leq +85^{\circ}C$		3.35	3.6	V
	Pre-charge hysteresis (referred to V_{OUT})		40	75		mV
V_{UVLO}	Undervoltage lockout threshold (analog circuitry)	V_{IN} falling		2.3	2.4	V
OUTPUT						
V_{OUT}	Output voltage range	Current regulation mode	V_{IN}		5.5	V
		Voltage regulation mode	3.825		5.7	V
	Internal feedback voltage accuracy	$2.5V \leq V_{IN} \leq 4.8V$, $-20^{\circ}C \leq T_J \leq +125^{\circ}C$ Boost mode, PWM voltage regulation	-2%		2%	
	Power-save mode ripple voltage	$I_{OUT} = 10$ mA		0.015 V_{OUT}		V_{P-P}
OVP	Output overvoltage protection	V_{OUT} rising, $0000 \leq OV[3:0] \leq 0100$	4.5	4.65	4.8	V
		V_{OUT} rising, $0101 \leq OV[3:0] \leq 1111$	5.8	6.0	6.2	V
	Output overvoltage protection hysteresis	V_{OUT} falling, $0101 \leq OV[3:0] \leq 1111$		0.15		V
POWER SWITCH						
$r_{DS(on)}$	Switch MOSFET on-resistance	$V_{OUT} = V_{GS} = 3.6$ V		90		m Ω
	Rectifier MOSFET on-resistance	$V_{OUT} = V_{GS} = 3.6$ V		135		m Ω
$I_{lkg(SW)}$	Leakage into SW	$V_{OUT} = 0V$, SW = 3.6V, $-40^{\circ}C \leq T_J \leq +85^{\circ}C$		0.3	4	μA
I_{lim}	Rectifier valley current limit (open-loop)	$V_{OUT} = 4.95V$, HC_SEL = 0 $-20^{\circ}C \leq T_J \leq +85^{\circ}C$ PWM operation, ILIM bit = 0 ⁽¹⁾	775	1150	1600	mA
		$V_{OUT} = 4.95V$, HC_SEL = 0 $-20^{\circ}C \leq T_J \leq +85^{\circ}C$ PWM operation, ILIM bit = 1 ⁽¹⁾	1050	1600	2225	mA
		$V_{OUT} = 4.95V$, HC_SEL = 1, Tx-MASK = 0 $-20^{\circ}C \leq T_J \leq +85^{\circ}C$ PWM operation, ILIM bit = 0 ⁽¹⁾	-85	30	150	mA
		$V_{OUT} = 4.95V$, HC_SEL = 1, Tx-MASK = 0 $-20^{\circ}C \leq T_J \leq +85^{\circ}C$ PWM operation, ILIM bit = 1	175	250	300	mA
OSCILLATOR						
f_{OSC}	Oscillator frequency			1.92		MHz
f_{ACC}	Oscillator frequency		-10		+7	%
THERMAL SHUTDOWN, HOT DIE DETECTOR						
	Thermal shutdown ⁽¹⁾		140	160		$^{\circ}C$
	Thermal shutdown hysteresis ⁽¹⁾			20		$^{\circ}C$
	Hot die detector accuracy ⁽¹⁾		-8		8	$^{\circ}C$

(1) Verified by characterization. Not tested in production.

ELECTRICAL CHARACTERISTICS (Continued)

Unless otherwise noted the specification applies for $V_{IN} = 3.6V$ over an operating junction temp. $-40^{\circ}C \leq T_J \leq 125^{\circ}C$; Circuit of Parameter Measurement Information section (unless otherwise noted). Typical values are for $T_J = 25^{\circ}C$.

PARAMETER		TEST CONDITIONS	MIN	TYP	MAX	UNIT	
LED CURRENT REGULATOR							
	LED1/3 current accuracy ⁽¹⁾	HC_SEL = 0	$0.4V \leq V_{LED1/3} \leq 2.0V$ $0mA < I_{LED1/3} \leq 111mA, T_J = +85^{\circ}C$		-10	+10	%
			$0.4V \leq V_{LED2} \leq 2.0V$ $I_{LED1/3} > 111mA, T_J = +85^{\circ}C$		-7.5	+7.5	%
	LED2 current accuracy ⁽¹⁾		$0.4V \leq V_{LED2} \leq 2.0V$ $0mA < I_{LED2} \leq 250mA, T_J = +85^{\circ}C$		-10	+10	%
			$0.4V \leq V_{LED2} \leq 2.0V$ $I_{LED2} > 250mA, T_J = +85^{\circ}C$		-7.5	+7.5	%
	LED1/3 current accuracy ⁽¹⁾	HC_SEL = 1	$0.4V \leq V_{LED1/3} \leq 2.0V$ $0mA < I_{LED1/3} \leq 1027mA, T_J = +85^{\circ}C$		-10	+10	%
			LED2 current accuracy ⁽¹⁾	$0.4V \leq V_{LED2} \leq 2.0V$ $0mA < I_{LED2} \leq 2052mA, T_J = +85^{\circ}C$		-10	+10
LED1/3 current matching ⁽¹⁾	HC_SEL = 0	$V_{LED1/3} = 1.0V, I_{LED1/3} = 444mA, T_J = +85^{\circ}C$		-7.5	+7.5	%	
LED1/2/3 current temperature coefficient					0.05	%/°C	
	INDLED current accuracy		$1.5V \leq (V_{IN} - V_{INDLED}) \leq 2.5V$ $0000 \leq INDC[3:0] \leq 0111$ $T_J = +25^{\circ}C$		-20	+20	%
INDLED current temperature coefficient					0.04	%/°C	
V _{DO}	LED1/2/3 sense voltage		$I_{LED1-3} = \text{full-scale current}, HC_SEL = 0$		400		mV
	LED1/2/3 sense voltage		$I_{LED1-3} = \text{full-scale current}, HC_SEL = 1$		400	450	mV
	VOUT dropout voltage		$I_{OUT} = -15.8mA, T_J = +25^{\circ}C, \text{device not switching}$			250	mV
	LED1/2/3 input leakage current		$V_{LED1/2/3} = V_{OUT} = 5V, -40^{\circ}C \leq T_J \leq +85^{\circ}C$		0.1	4	μA
	INDLED input leakage current		$V_{INDLED} = 0V, -40^{\circ}C \leq T_J \leq +85^{\circ}C$		0.1	1	μA

(1) Verified by characterization. Not tested in production.

ELECTRICAL CHARACTERISTICS

Unless otherwise noted the specification applies for $V_{IN} = 3.6V$ over an operating junction temp. $-40^{\circ}C \leq T_J \leq 125^{\circ}C$; Circuit of Parameter Measurement Information section (unless otherwise noted). Typical values are for $T_J = 25^{\circ}C$.

PARAMETER		TEST CONDITIONS	MIN	TYP	MAX	UNIT
STORAGE CAPACITOR ACTIVE CELL BALANCING						
Active cell balancing circuitry quiescent current into VOUT		HC_SEL = 1, storage capacitor balanced $-40^{\circ}C \leq T_J \leq +85^{\circ}C$		1.7	3.0	μA
Active cell balancing accuracy		(VOUT – BAL) vs. BAL voltage difference Storage capacitor balanced HC_SEL = 1 VOUT = 5.7V	-100		100	mV
BAL output drive capability		VOUT = 4.95V, Sink and source current	± 10	± 15		mA
Active discharge resistor		HC_SEL = 0, device in shutdown mode VOUT to BAL and BAL to GND		0.85	1.5	k Ω
LED TEMPERATURE MONITORING						
$I_{O(TS)}$	Temperature Sense Current Source	Thermistor bias current		23.8		μA
	TS Resistance (Warning Temperature)	LEDWARN bit = 1, $T_J \geq 25^{\circ}C$	39	44.5	50	k Ω
	TS Resistance (Hot Temperature)	LEDHOT bit = 1, $T_J \geq 25^{\circ}C$	12.5	14.5	16.5	k Ω
SDA, SCL, GPIO/PG, Tx-MASK, STRB0, STRB1, HC_SEL						
$V_{(IH)}$	High-level input voltage		1.2			V
$V_{(IL)}$	Low-level input voltage				0.4	V
$V_{(OL)}$	Low-level output voltage (SDA)	$I_{OL} = 8mA$			0.3	V
	Low-level output voltage (GPIO)	DIR = 1, $I_{OL} = 5mA$			0.3	V
$V_{(OH)}$	High-level output voltage (GPIO)	DIR = 1, GPIOTYPE = 0, $I_{OH} = 8mA$	$V_{IN}-0.4$			V
$I_{(LKG)}$	Logic input leakage current	Input connected to VIN or GND $-40^{\circ}C \leq T_J \leq +85^{\circ}C$		0.01	0.1	μA
R_{PD}	STRB0, STRB1 pull-down resistance	STRB0, STRB1 $\leq 0.4 V$		350		k Ω
	Tx-MASK pull-down resistance	Tx-MASK $\leq 0.4 V$		350		k Ω
	HC_SEL pull-down resistance	HC_SEL $\leq 0.4 V$		350		k Ω
$C_{(IN)}$	SDA Input Capacitance	SDA = VIN or GND		9		pF
	SCL Input Capacitance	SCL = VIN or GND		4		pF
	GPIO/PG Input Capacitance	DIR = 0, GPIO/PG = VIN or GND		9		pF
	STRB0 Input Capacitance	STRB0 = VIN or GND		3		pF
	STRB1 Input Capacitance	STRB1 = VIN or GND		3		pF
	HC_SEL Input Capacitance	HC_SEL = VIN or GND		3.5		pF
	Tx-MASK Input Capacitance	Tx-MASK = VIN or GND		4		pF

ELECTRICAL CHARACTERISTICS (continued)

Unless otherwise noted the specification applies for $V_{IN} = 3.6V$ over an operating junction temp. $-40^{\circ}C \leq T_J \leq 125^{\circ}C$; Circuit of Parameter Measurement Information section (unless otherwise noted). Typical values are for $T_J = 25^{\circ}C$.

PARAMETER	TEST CONDITIONS	MIN	TYP	MAX	UNIT
TIMING					
Start-up time	From shutdown into DC light mode HC_SEL = 0, $I_{LED} = 111mA$		1.5		ms
LED current settling time ⁽¹⁾ triggered by a rising edge on STRB0	MODE_CTRL[1:0] = 10, HC_SEL = 0 $I_{LED2} = \text{from } 0mA \text{ to } 890mA$		400		μs
	MODE_CTRL[1:0] = 10, HC_SEL = 1 $I_{LED2} = \text{from } 0mA \text{ to } 2050mA$		16		μs
LED current settling time ⁽¹⁾ triggered by Tx-MASK	MODE_CTRL[1:0] = 10, HC_SEL = 0 $I_{LED2} = \text{from } 890mA \text{ to } 390mA$		15		μs

(1) Settling time to $\pm 15\%$ of the target value.

I²C INTERFACE TIMING CHARACTERISTICS⁽¹⁾

PARAMETER	TEST CONDITIONS	MIN	MAX	UNIT
$f_{(SCL)}$ SCL Clock Frequency	Standard mode		100	kHz
	Fast mode		400	kHz
	High-speed mode (write operation), $C_B - 100 pF$ max		3.4	MHz
	High-speed mode (read operation), $C_B - 100 pF$ max		3.4	MHz
	High-speed mode (write operation), $C_B - 400 pF$ max		1.7	MHz
	High-speed mode (read operation), $C_B - 400 pF$ max		1.7	MHz
t_{BUF} Bus Free Time Between a STOP and START Condition	Standard mode		4.7	μs
	Fast mode		1.3	μs
t_{HD}, t_{STA} Hold Time (Repeated) START Condition	Standard mode		4	μs
	Fast mode		600	ns
	High-speed mode		160	ns
t_{LOW} LOW Period of the SCL Clock	Standard mode		4.7	μs
	Fast mode		1.3	μs
	High-speed mode, $C_B - 100 pF$ max		160	ns
	High-speed mode, $C_B - 400 pF$ max		320	ns
t_{HIGH} HIGH Period of the SCL Clock	Standard mode		4	μs
	Fast mode		600	ns
	High-speed mode, $C_B - 100 pF$ max		60	ns
	High-speed mode, $C_B - 400 pF$ max		120	ns
t_{SU}, t_{STA} Setup Time for a Repeated START Condition	Standard mode		4.7	μs
	Fast mode		600	ns
	High-speed mode		160	ns
t_{SU}, t_{DAT} Data Setup Time	Standard mode		250	ns
	Fast mode		100	ns
	High-speed mode		10	ns
t_{HD}, t_{DAT} Data Hold Time	Standard mode		0	3.45 μs
	Fast mode		0	0.9 μs
	High-speed mode, $C_B - 100 pF$ max		0	70 ns
	High-speed mode, $C_B - 400 pF$ max		0	150 ns
t_{RCL} Rise Time of SCL Signal	Standard mode	$20 + 0.1 C_B$	1000	ns
	Fast mode	$20 + 0.1 C_B$	300	ns
	High-speed mode, $C_B - 100 pF$ max		10	40 ns
	High-speed mode, $C_B - 400 pF$ max		20	80 ns

(1) Specified by design. Not tested in production.

I²C INTERFACE TIMING CHARACTERISTICS⁽¹⁾ (continued)

PARAMETER		TEST CONDITIONS	MIN	MAX	UNIT
t _{RCL1}	Rise Time of SCL Signal After a Repeated START Condition and After an Acknowledge BIT	Standard mode	20 + 0.1 C _B	1000	ns
		Fast mode	20 + 0.1 C _B	300	ns
		High-speed mode, C _B – 100 pF max	10	80	ns
		High-speed mode, C _B – 400 pF max	20	160	ns
t _{FCL}	Fall Time of SCL Signal	Standard mode	20 + 0.1 C _B	300	ns
		Fast mode	20 + 0.1 C _B	300	ns
		High-speed mode, C _B – 100 pF max	10	40	ns
		High-speed mode, C _B – 400 pF max	20	80	ns
t _{RDA}	Rise Time of SDA Signal	Standard mode	20 + 0.1 C _B	1000	ns
		Fast mode	20 + 0.1 C _B	300	ns
		High-speed mode, C _B – 100 pF max	10	80	ns
		High-speed mode, C _B – 400 pF max	20	160	ns
t _{FDA}	Fall Time of SDA Signal	Standard mode	20 + 0.1 C _B	300	ns
		Fast mode	20 + 0.1 C _B	300	ns
		High-speed mode, C _B – 100 pF max	10	80	ns
		High-speed mode, C _B – 400 pF max	20	160	ns
t _{SU} , t _{STO}	Setup Time for STOP Condition	Standard mode	4		μs
		Fast mode	600		ns
		High-speed mode	160		ns
C _B	Capacitive Load for SDA and SCL		400		pF

DEVICE INFORMATION
PIN FUNCTIONS

PIN		I/O	DESCRIPTION
NAME	NO.		
AVIN	E4	I	This is the input voltage pin of the device. Connect directly to the input bypass capacitor.
VOUT	A2	O	This is the output voltage pin of the converter.
LED1	E2	I	LED return input. This feedback pin regulates the LED current through the internal sense resistor by regulating the voltage across it. The regulation operates with typically 400mV (HC_SEL = L) or 400mV (HC_SEL = H) dropout voltage. Connect to the cathode of the LEDs.
LED2	E1	I	
LED3	E3	I	
STRB0	B4	I	LED1/2/3 enable logic input. This pin can be used to enable/disable the high-power LEDs connected to the device. STRB0 = LOW: LED1, LED2 and LED3 current regulators are turned-off. STRB0 = HIGH: LED2, LED2 and LED3 current regulators are active. The LED current level (DC light or flashlight current) is defined according to the STRB1 logic level.
HC_SEL	B3	I	Extended high-current mode selection input. This pin must not be left floating and must be terminated. HC_SEL = LOW: LED direct drive mode. The power stage is active and the maximum LED currents are defined as 445mA/890mA/445mA (ILED1/ILED2/ILED3). HC_SEL = HIGH: Energy storage mode. In flash mode, the power stage is either active with reduced current capability or disabled. The maximum LED current is defined as 1025mA/2050mA/1025mA (ILED1/ILED2/ILED3).
SCL	B2	I	Serial interface clock line. This pin must not be left floating and must be terminated.
SDA	B1	I/O	Serial interface address/data line. This pin must not be left floating and must be terminated.
GPIO/PG	D4	I/O	This pin can either be configured as a general purpose input/output pin (GPIO) or either as an open-drain or a push-pull output to signal when the converters output voltage is within the regulation limits (PG). Per default, the pin is configured as an open-drain power-good output.
TS	C4	I/O	NTC resistor connection. This pin can be used to monitor the LED temperature. Connect a 220kΩ NTC resistor from the TS input to ground. In case this functionality is not desired, the TS input should be tied to AVIN or left floating.
INDLED	A1	O	This pin provides a constant current source to drive low V_F LEDs. Connect to LED anode.
STRB1	D3	I	LED current level selection input. Pulling this input high disables the DC light watchdog timer. STRB1 = LOW: Flash light mode is enabled. STRB1 = HIGH: DC light mode is enabled.
Tx-MASK	C3	I	RF PA synchronization control input.
SW	C1 C2	I/O	Inductor connection. Drain of the internal power MOSFET. Connect to the switched side of the inductor. SW is high impedance during shutdown.
BAL	A3	O	Balancing output for dual cells super-capacitor. In steady-state operation, this output compensates for leakage current mismatch between the cells.
PGND	D1 D2		Power ground. Connect to AGND underneath IC.
AGND	A4		Analog ground.

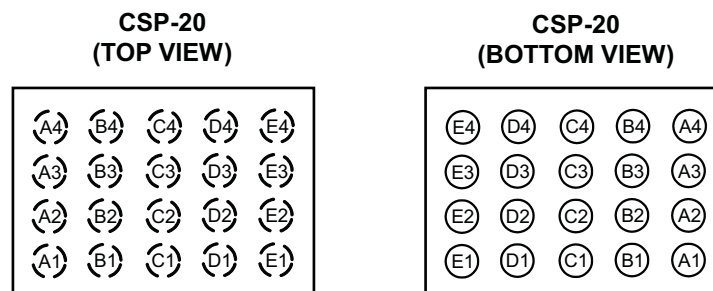
Figure 4. PIN ASSIGNMENTS

FUNCTIONAL BLOCK DIAGRAM

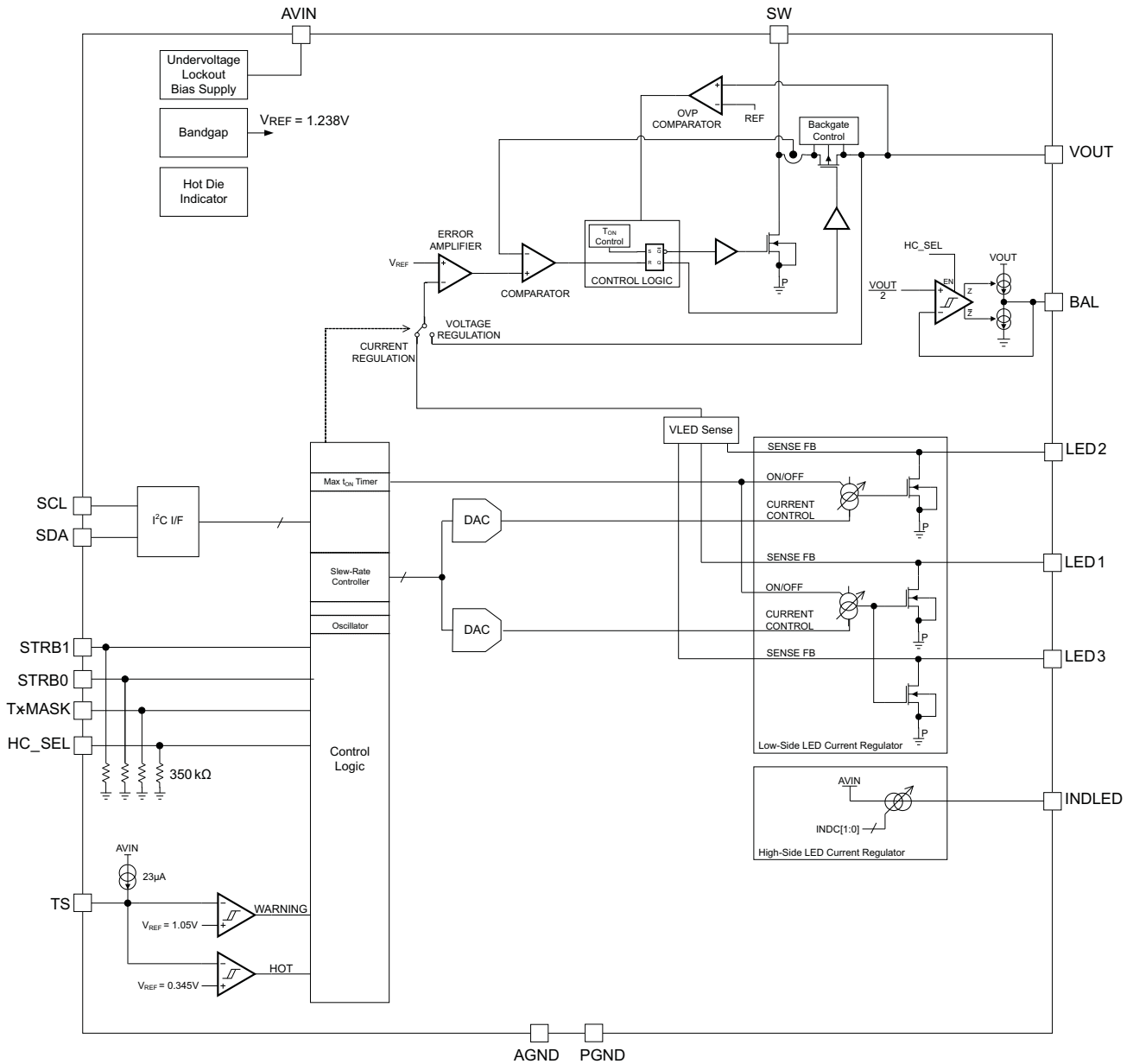

PARAMETER MEASUREMENT INFORMATION

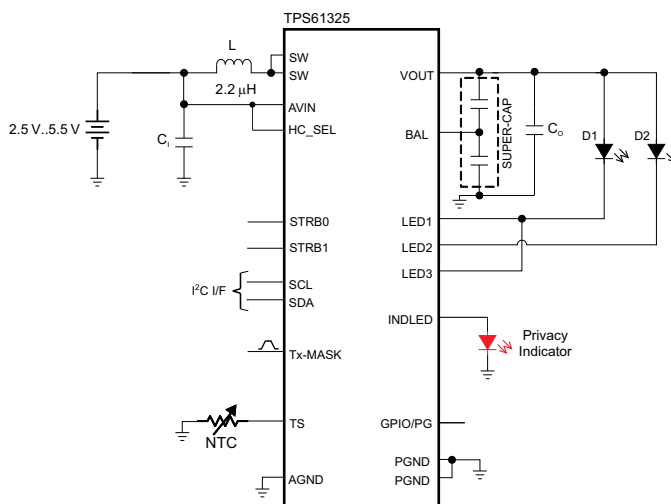

List of Components:

- L = 2.2µH, Wuerth Elektronik WE-TPC Series
- C₁, C₀ = 10µF 6.3V X5R 0603 – TDK C1605X5R0J106MT
- Storage Capacitor = TDK EDLC262020-500mF
- NTC = 220kΩ, muRata NCP18WM224J03RB

TYPICAL CHARACTERISTICS

Table of Graphs

		FIGURE
LED Power Efficiency	vs. Input Voltage	Figure 4, Figure 5
DC Input Current	vs. Input Voltage	Figure 6
LED Current	vs. LED Pin Headroom Voltage	Figure 7, Figure 8, Figure 9
LED Current	vs. LED Current Digital Code	Figure 10, Figure 11, Figure 12, Figure 13
INDLED Current	vs. LED Pin Headroom Voltage	Figure 14
Voltage Mode Efficiency	vs. Output Current	Figure 15, Figure 16
DC Output Voltage	vs. Output Current	Figure 17
	vs. Input Voltage	Figure 18
Maximum Output Current	vs. Input Voltage	Figure 19
DC Pre-Charge Current	vs. Differential Input-Output Voltage	Figure 20, Figure 21
Valley Current Limit		Figure 22, Figure 23
Balancing Current	vs. Balance Pin Voltage	Figure 24
Supply Current	vs. Input Voltage	Figure 25
Standby Current	vs. Ambient Temperature	Figure 26
Temperature Detection Threshold		Figure 27, Figure 28
Junction Temperature	vs. Port Voltage	Figure 29
Flash Sequence (Direct Drive Mode)		Figure 30
Tx-Masking Operation		Figure 31, Figure 32, Figure 33
Low-Light Dimming Mode Operation		Figure 34
PWM Operation		Figure 35
PFM Operation		Figure 36
Down-Mode Operation (Voltage Mode)		Figure 37
Voltage Mode Load Transient Response		Figure 38
Start-up Into DC Light Operation		Figure 39
Start-up Into Voltage Mode Operation		Figure 40
Storage Capacitor Pre-Charge		Figure 41
Storage Capacitor Charge-Up		Figure 42, Figure 43, Figure 44
DC Light Operation (Energy Storage Mode)		Figure 45
Flash Sequence (Energy Storage Mode)		Figure 46, Figure 47, Figure 48, Figure 49
Junction Temperature Monitoring		Figure 50
Shutdown (Energy Storage Mode)		Figure 51

TYPICAL CHARACTERISTICS (continued)

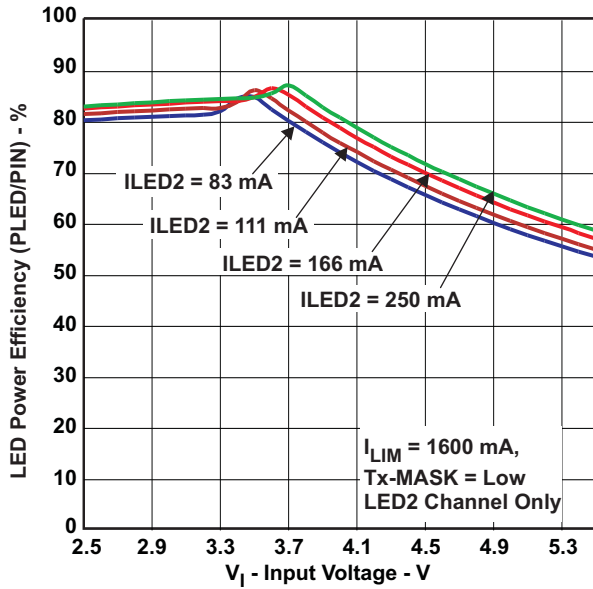

Figure 5. LED Power Efficiency vs. Input Voltage

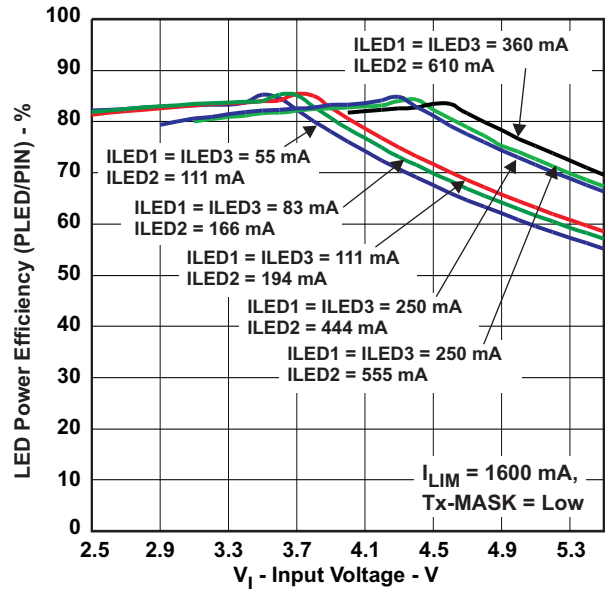

Figure 6. LED Power Efficiency vs. Input Voltage

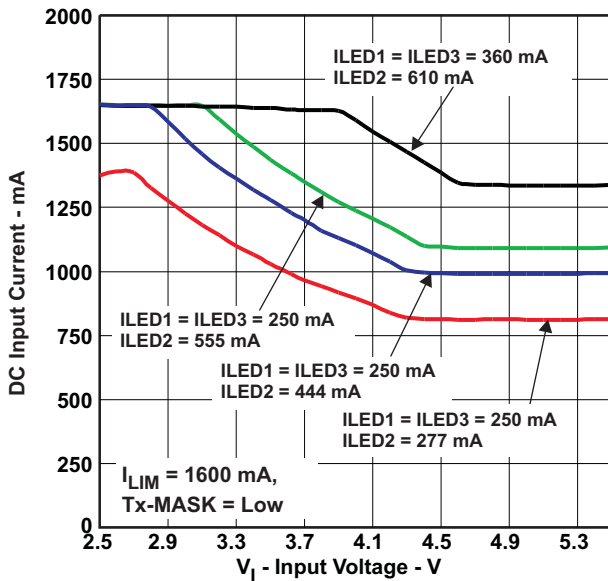

Figure 7. DC Input Current vs. Input Voltage

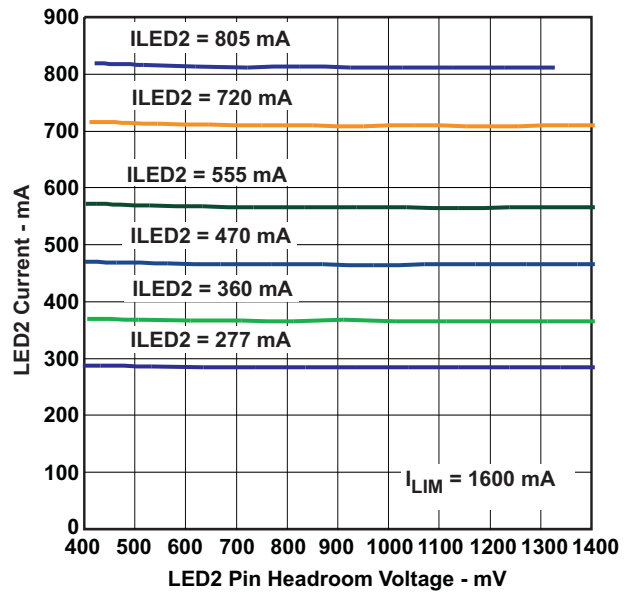

Figure 8. LED2 Current vs. LED2 Pin Headroom Voltage (HC_SEL=0)

TYPICAL CHARACTERISTICS (continued)

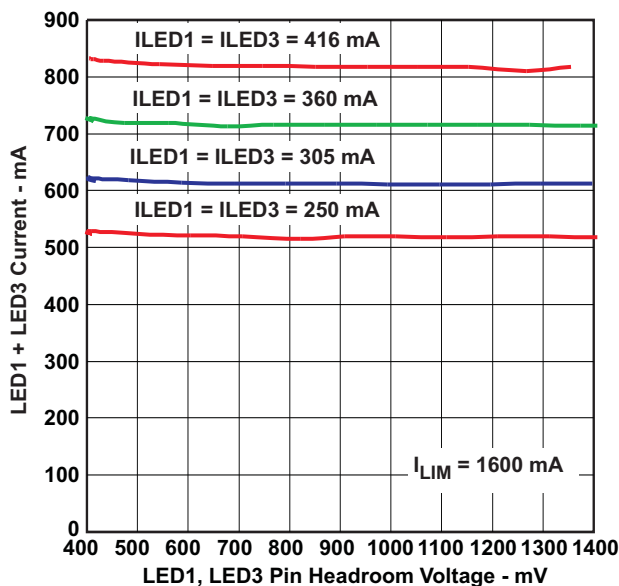

Figure 9. LED1+LED3 Current vs. LED1+LED3 Pin Headroom Voltage (HC_SEL=0)

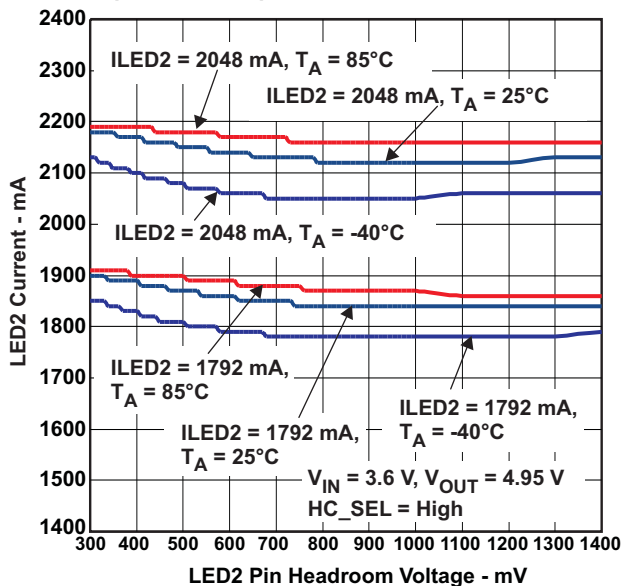

Figure 10. LED2 Current vs. LED2 Pin Headroom Voltage (HC_SEL=1)

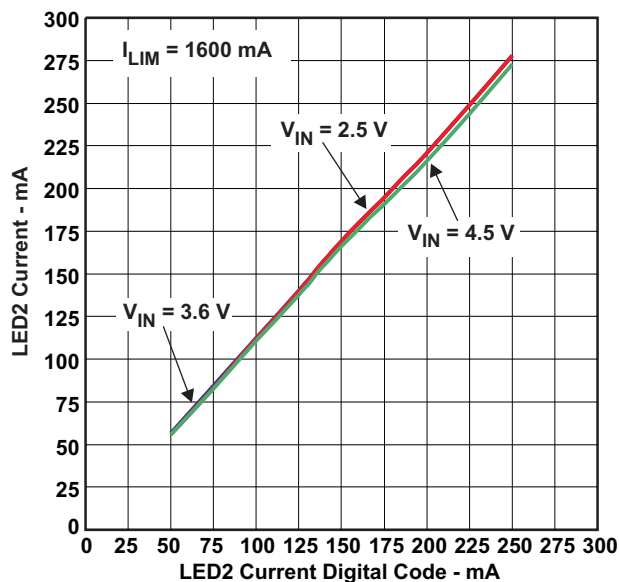

Figure 11. LED2 Current vs. LED2 Current Digital Code (HC_SEL=0)

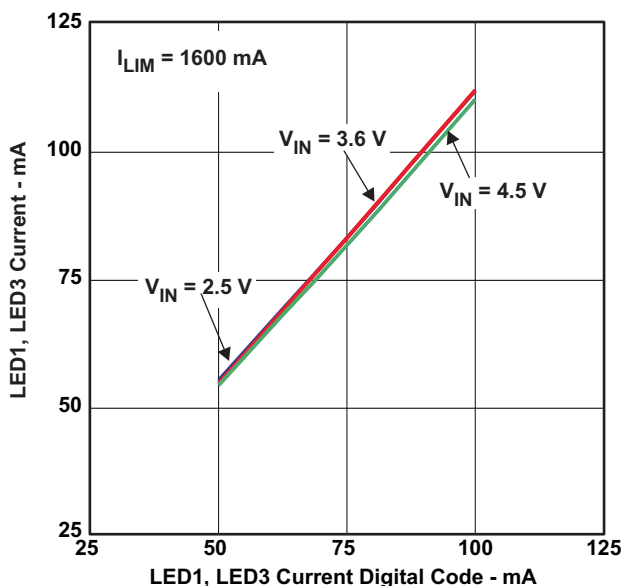

Figure 12. LED1, LED3 Current vs. LED1, LED3 Current Digital Code (HC_SEL=0)

TYPICAL CHARACTERISTICS (continued)

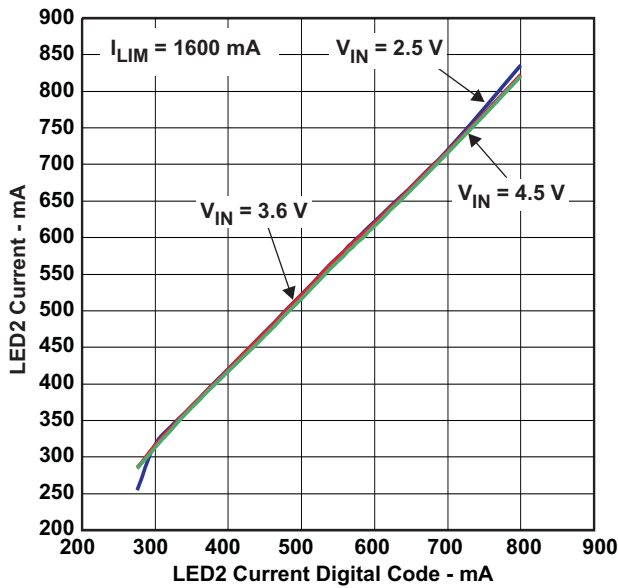

Figure 13. LED2 Current vs. LED2 Current Digital Code (HC_SEL=0)

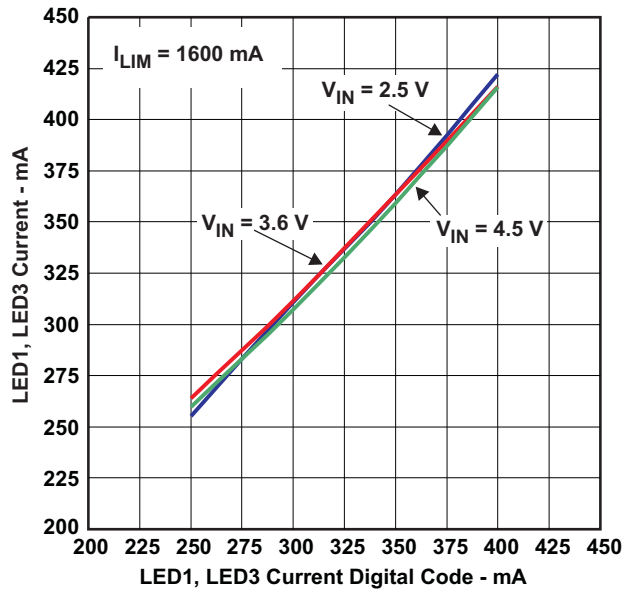

Figure 14. LED1, LED3 Current vs. LED1, LED3 Current Digital Code (HC_SEL=0)

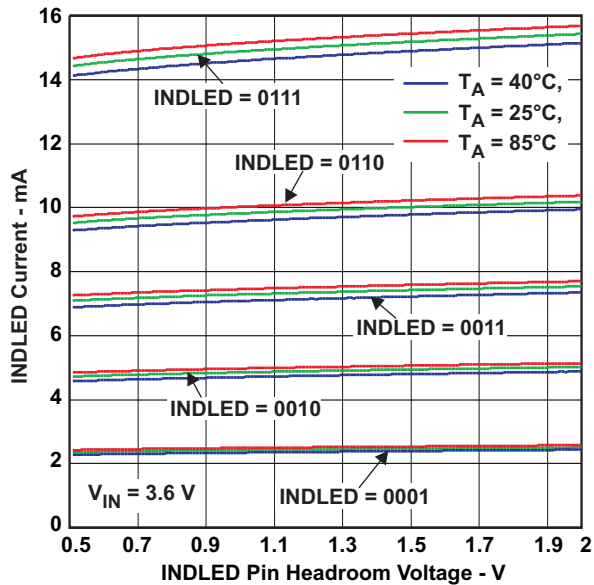

Figure 15. INDLED Current vs. INDLED Pin Headroom Voltage

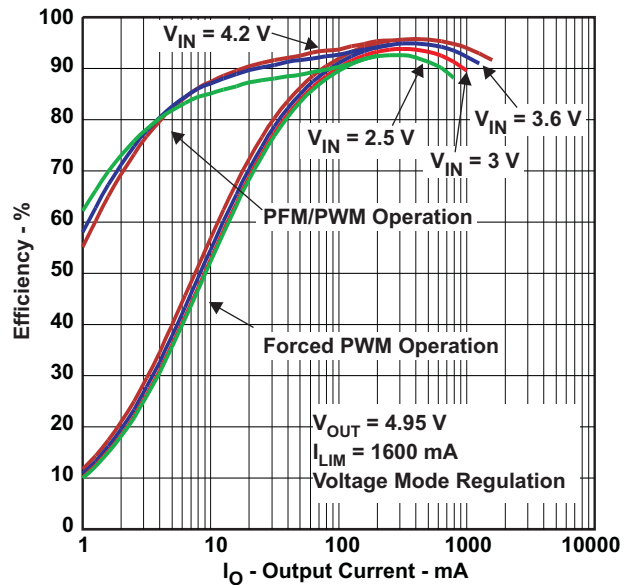

Figure 16. Efficiency vs Output Current

TYPICAL CHARACTERISTICS (continued)

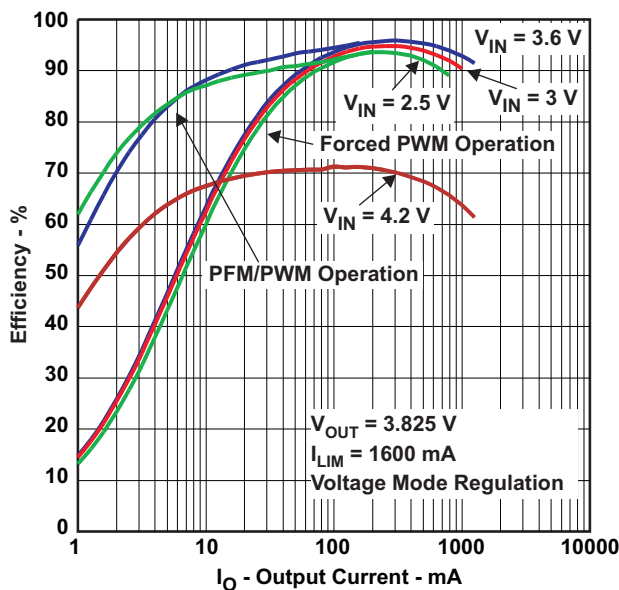

Figure 17. Efficiency vs. Output Current

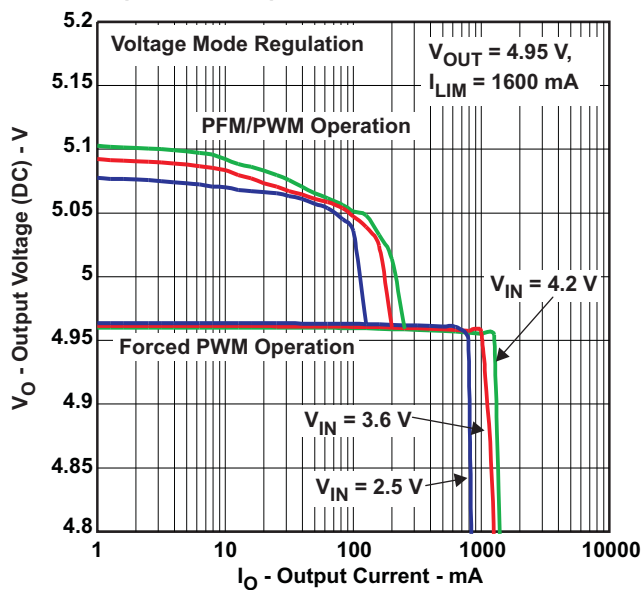

Figure 18. DC Output Voltage vs. Load Current

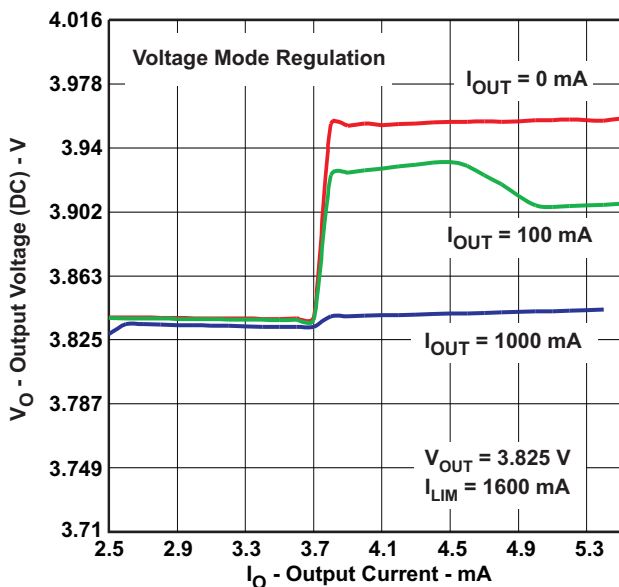

Figure 19. DC Output Voltage vs. Input Voltage

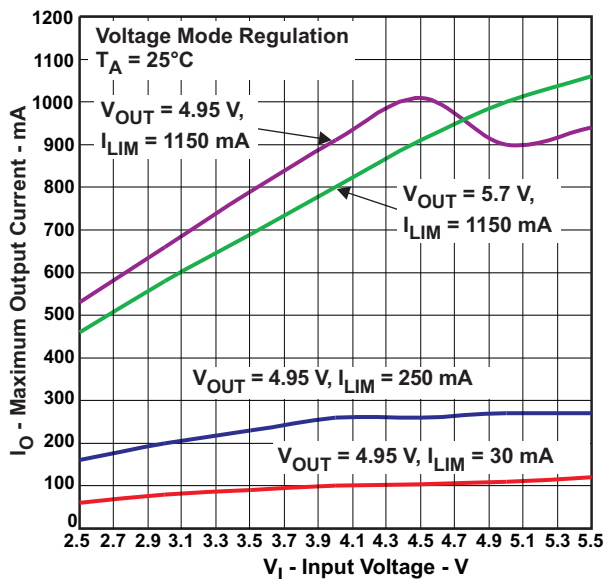

Figure 20. Maximum Output Current vs. Input Voltage

TYPICAL CHARACTERISTICS (continued)

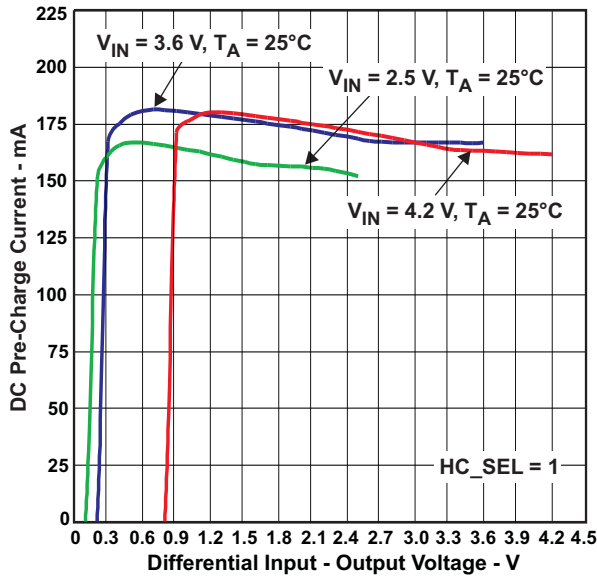

Figure 21. DC Pre-Charge Current vs. Differential Input-Output Voltage (HC_SEL=1)

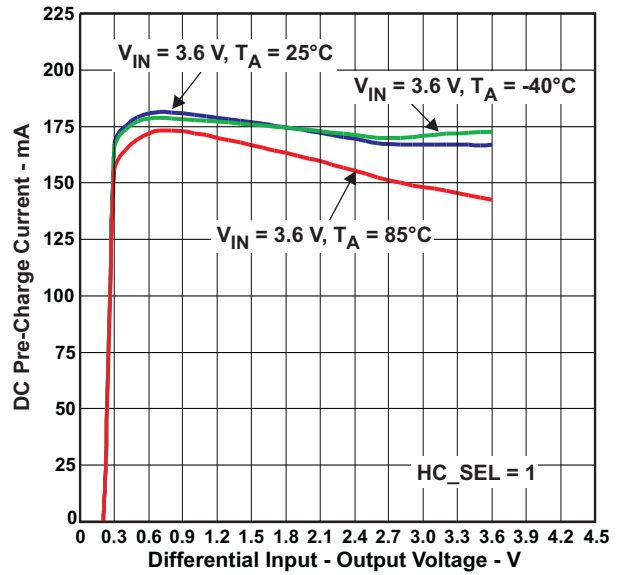

Figure 22. DC Pre-Charge Current vs. Differential Input-Output Voltage (HC_SEL=1)

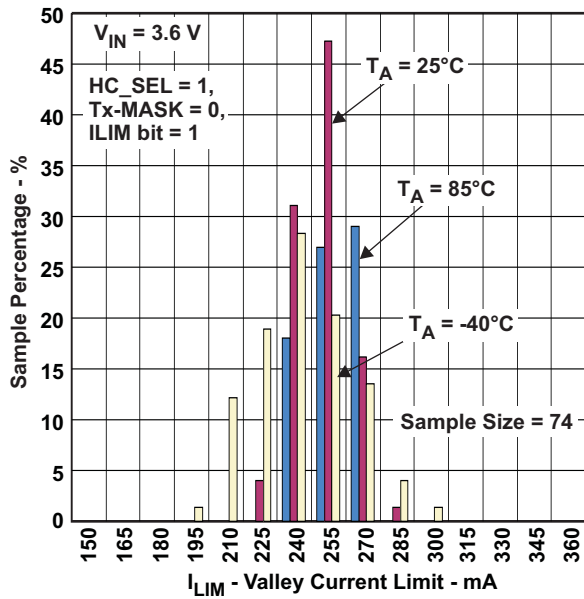

Figure 23. Valley Current Limit (HC_SEL=1)

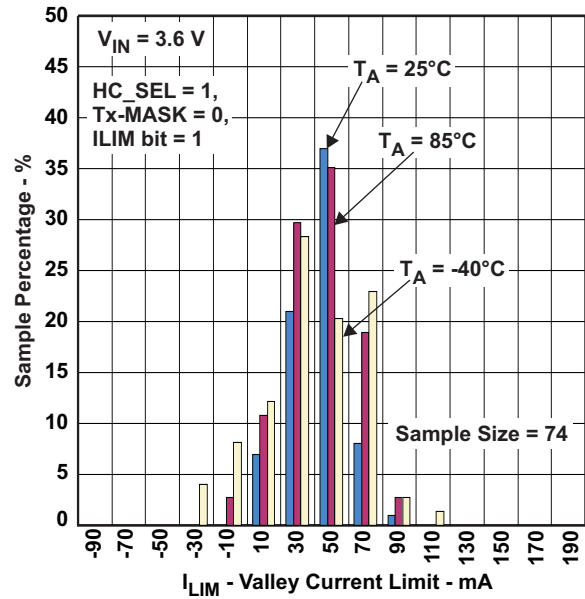

Figure 24. Valley Current Limit (HC_SEL=1)

TYPICAL CHARACTERISTICS (continued)

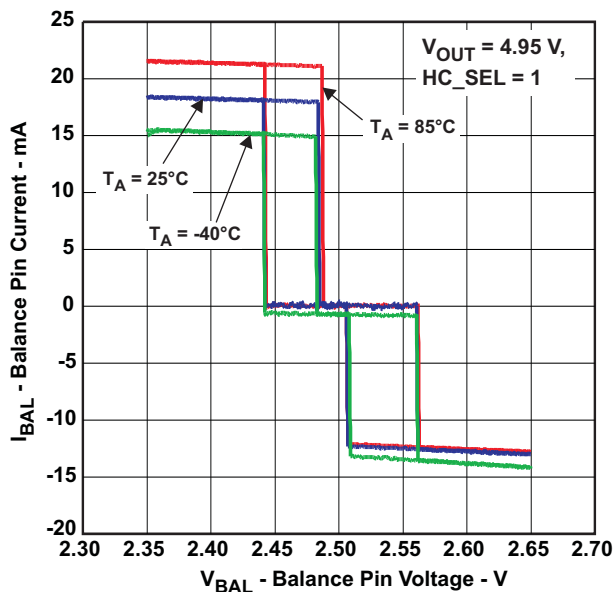

Figure 25. Balancing Current vs. Balance Pin Voltage

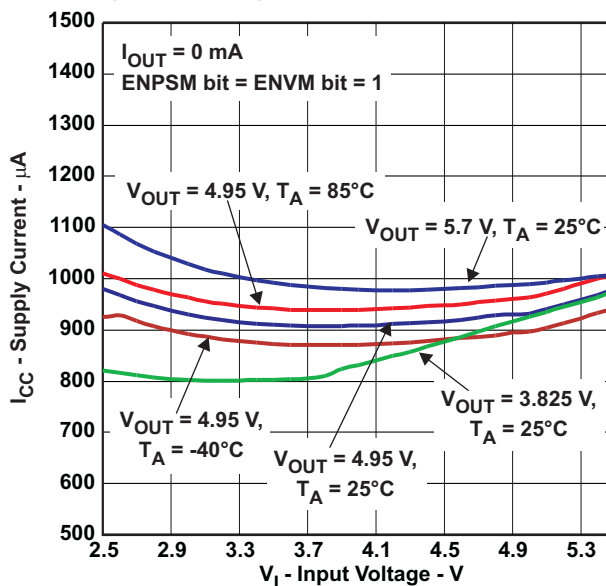

Figure 26. Supply Current vs. Input Voltage

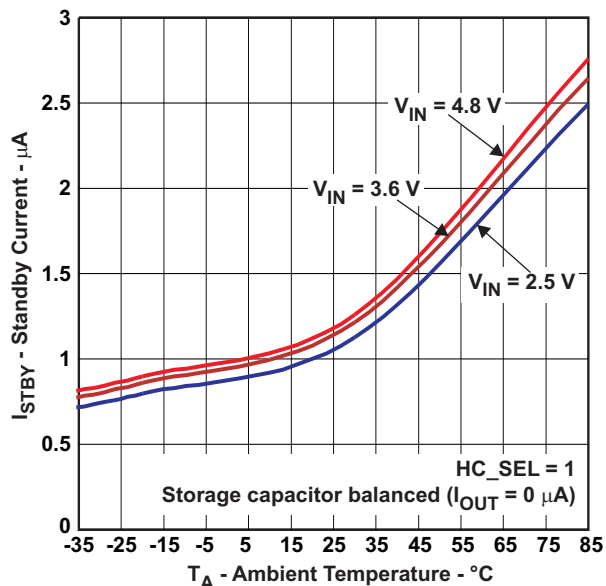

Figure 27. Standby Current vs. Ambient Temperature (HC_SEL=1)

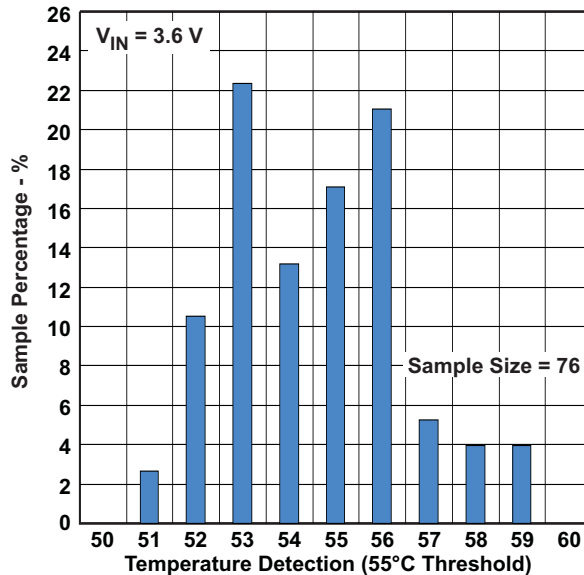

Figure 28. Temperature Detection Threshold

TYPICAL CHARACTERISTICS (continued)

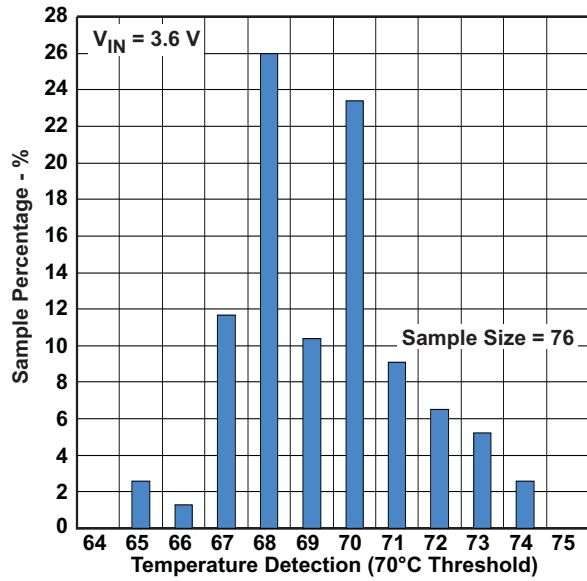

Figure 29. Temperature Detection Threshold

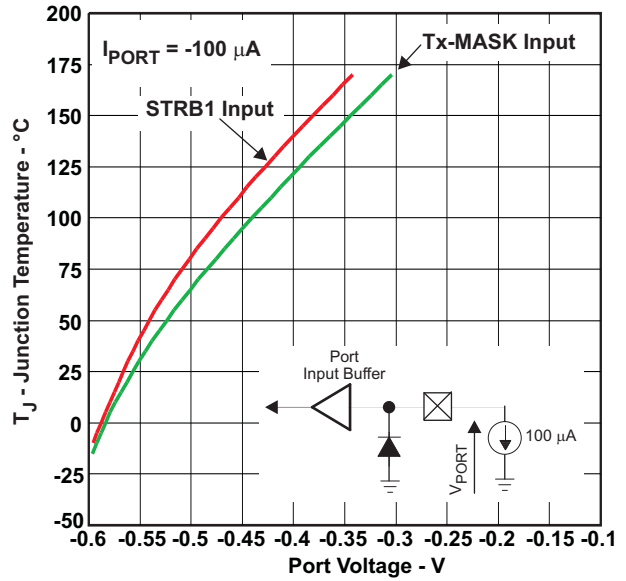

Figure 30. Junction Temperature vs. Port Voltage

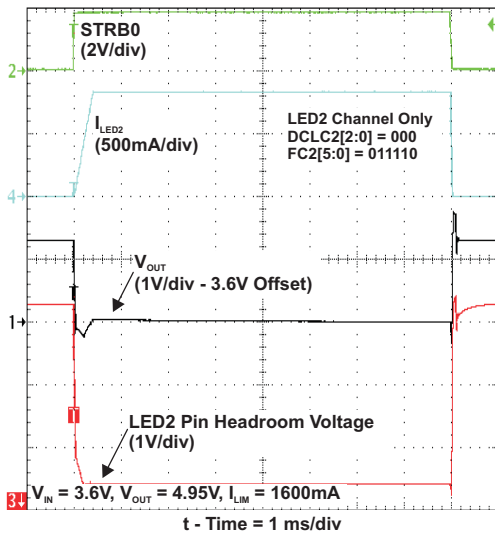

Figure 31. FLASH SEQUENCE (HC_SEL=0)

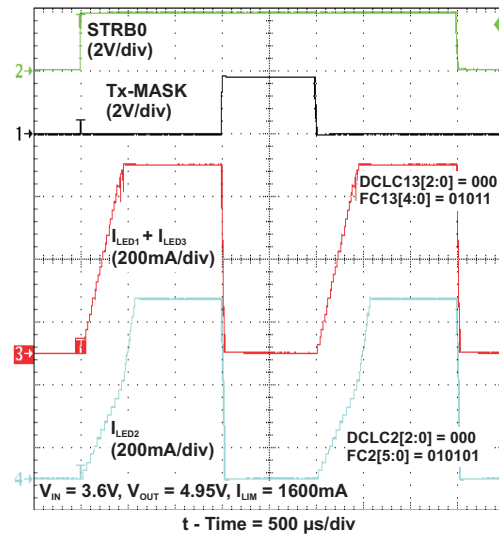

Figure 32. Tx-MASKING OPERATION (HC_SEL=0)

TYPICAL CHARACTERISTICS (continued)

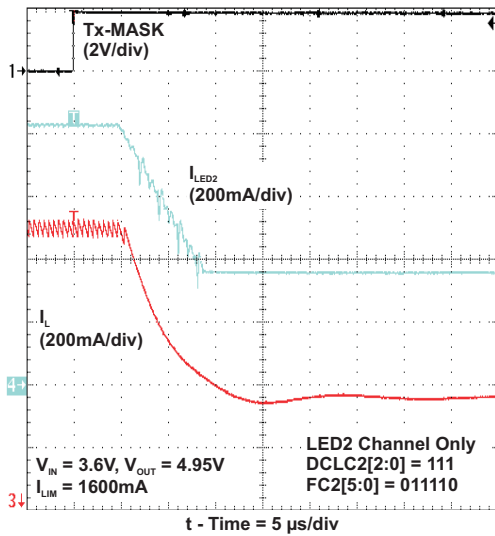

Figure 33. Tx-MASKING OPERATION ($HC_SEL=0$)

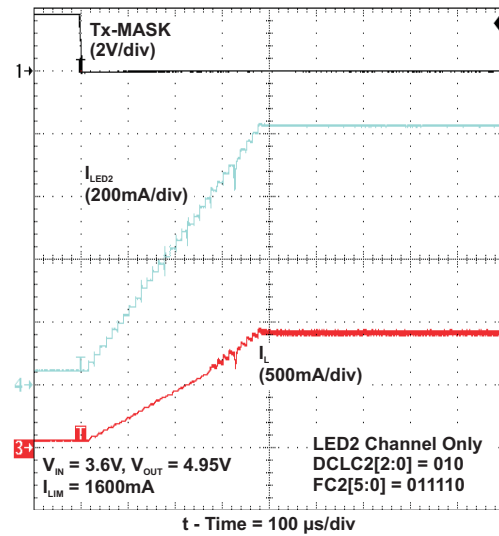

Figure 34. Tx-MASKING OPERATION ($HC_SEL=0$)

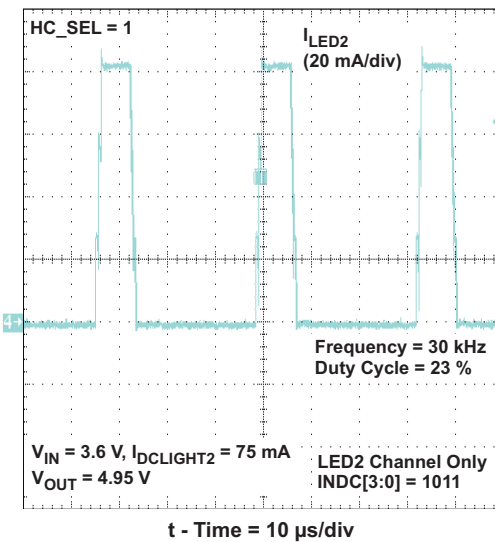

Figure 35. LOW-LIGHT DIMMING MODE OPERATION

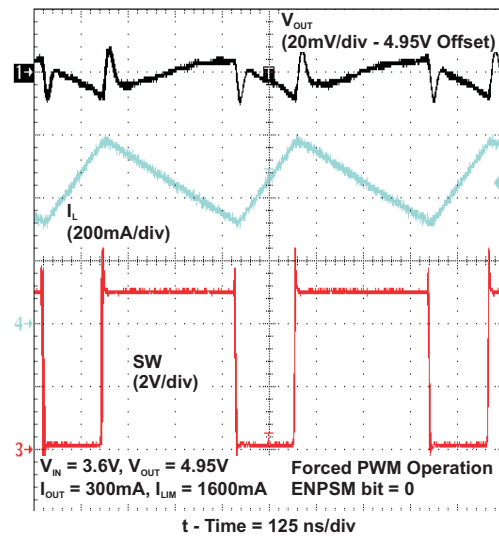

Figure 36. PWM OPERATION

TYPICAL CHARACTERISTICS (continued)

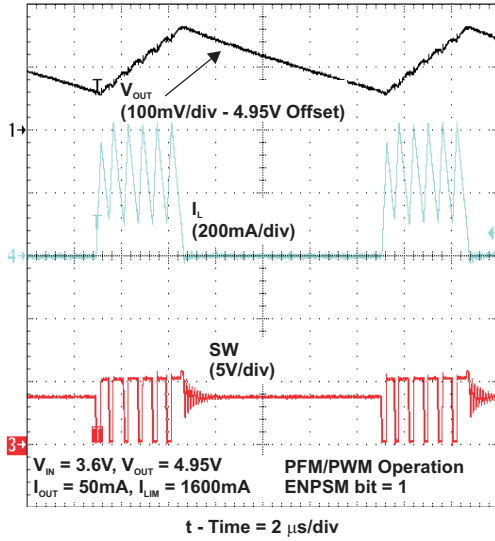

Figure 37. PFM OPERATION

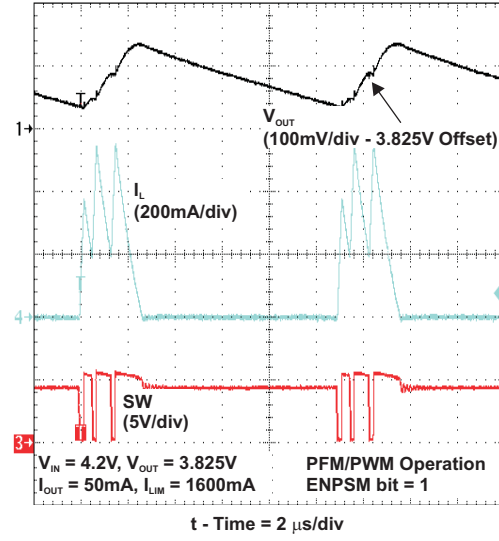

Figure 38. DOWN-MODE OPERATION (VOLTAGE MODE)

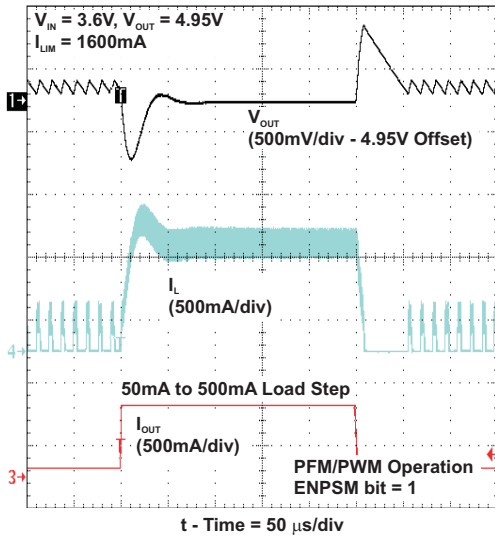

Figure 39. VOLTAGE MODE LOAD TRANSIENT RESPONSE

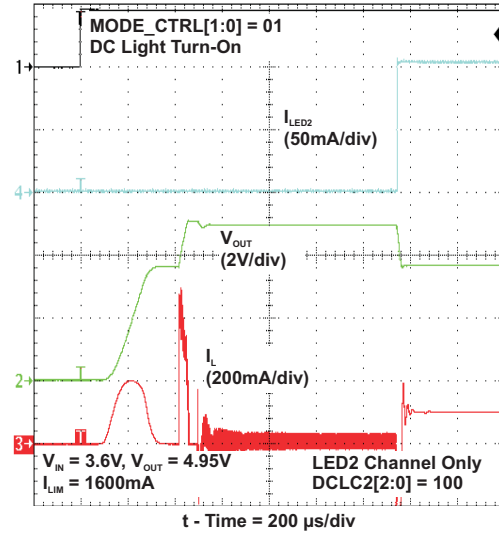

Figure 40. START-UP INTO DC LIGHT OPERATION

TYPICAL CHARACTERISTICS (continued)

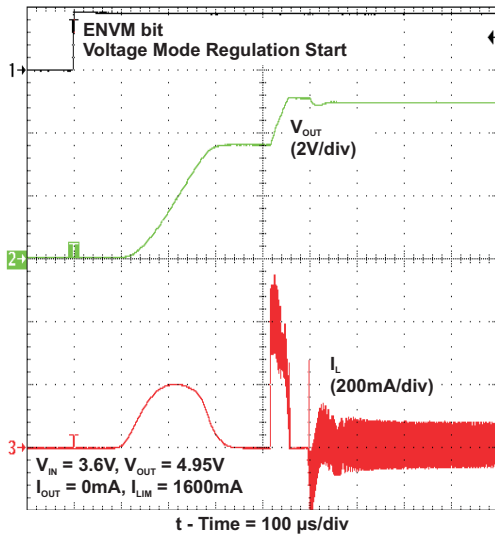

Figure 41. START-UP INTO VOLTAGE MODE OPERATION

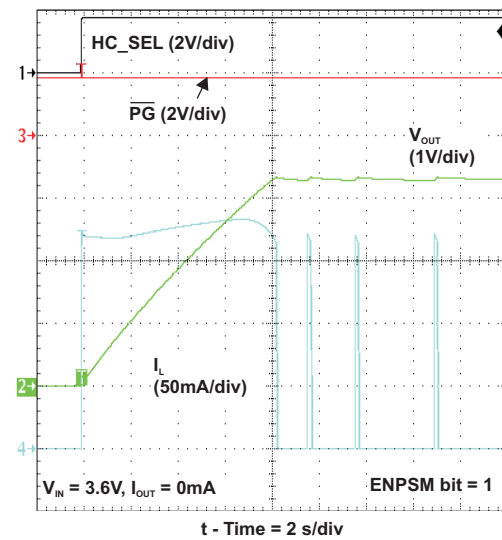

Figure 42. STORAGE CAPACITOR PRE-CHARGE (HC_SEL=1)

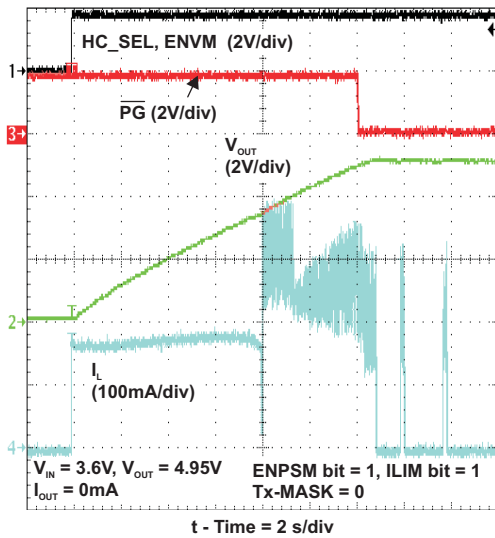

Figure 43. STORAGE CAPACITOR CHARGE-UP (HC_SEL=1)

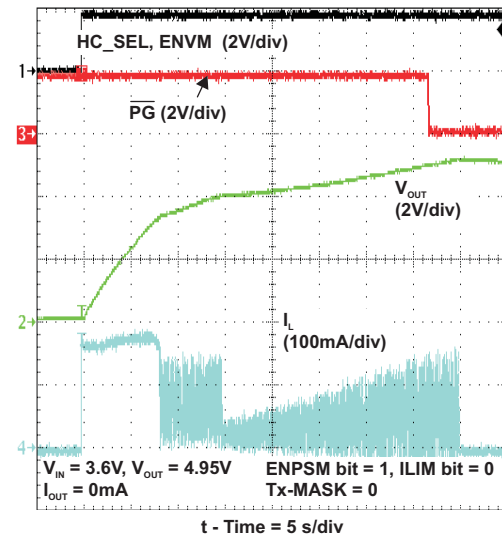

Figure 44. STORAGE CAPACITOR CHARGE-UP (HC_SEL=1)

TYPICAL CHARACTERISTICS (continued)

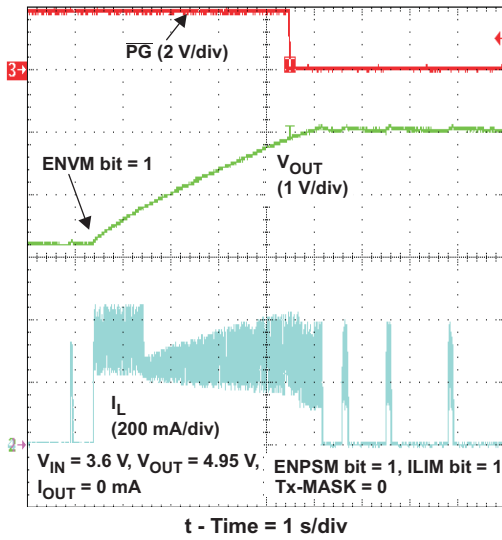

Figure 45. STORAGE CAPACITOR CHARGE-UP (HC_SEL=1)

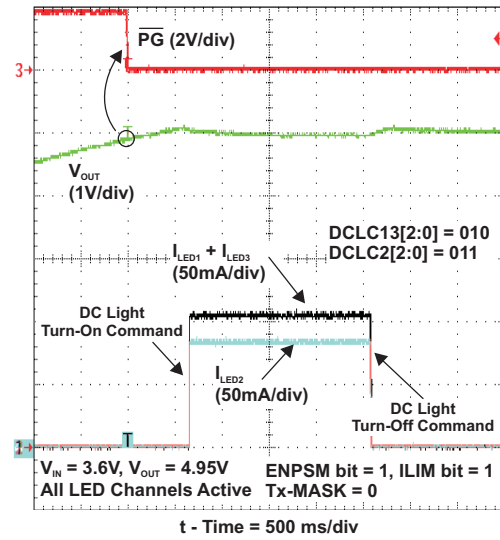

Figure 46. DC LIGHT OPERATION (HC_SEL=1)

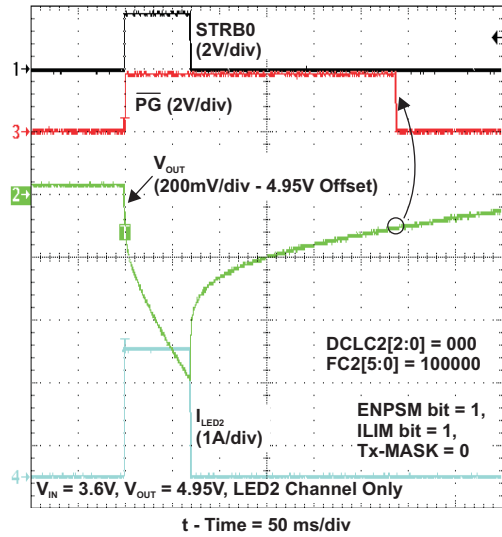

Figure 47. FLASH SEQUENCE (HC_SEL=1)

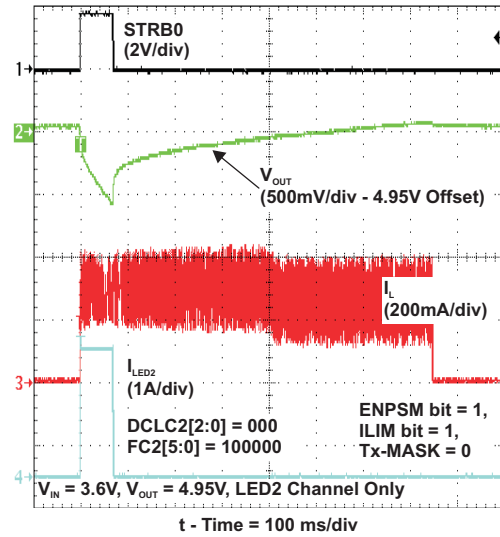

Figure 48. FLASH SEQUENCE (HC_SEL=1)

TYPICAL CHARACTERISTICS (continued)

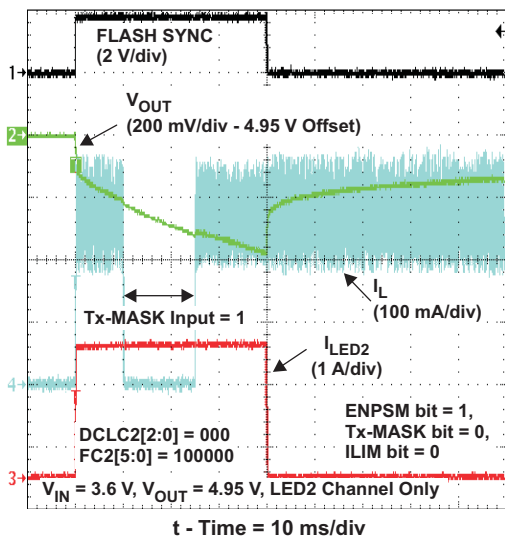

Figure 49. FLASH SEQUENCE (HC_SEL=1)

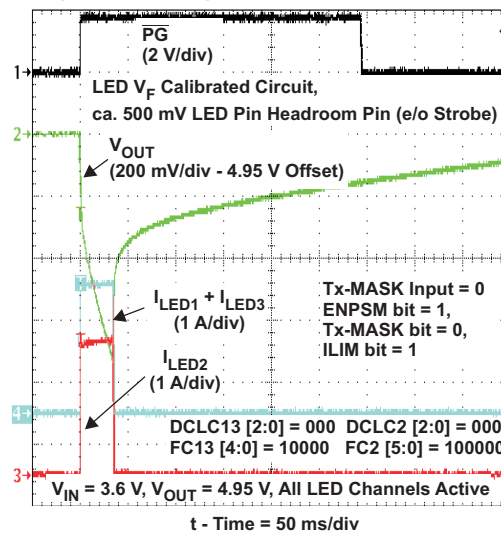

Figure 50. FLASH SEQUENCE (HC_SEL=1)

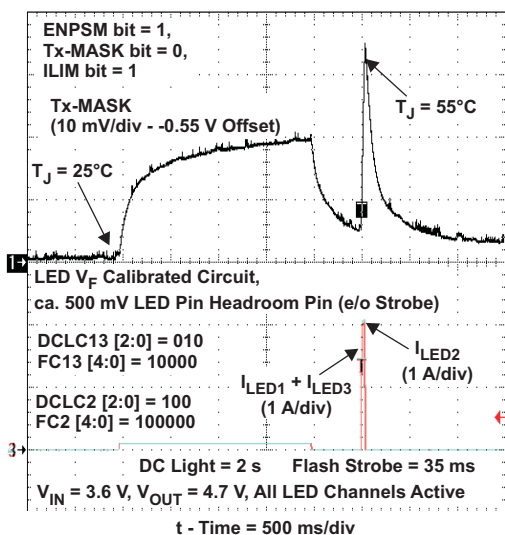

Figure 51. JUNCTION TEMPERATURE MONITORING (HC_SEL=1)

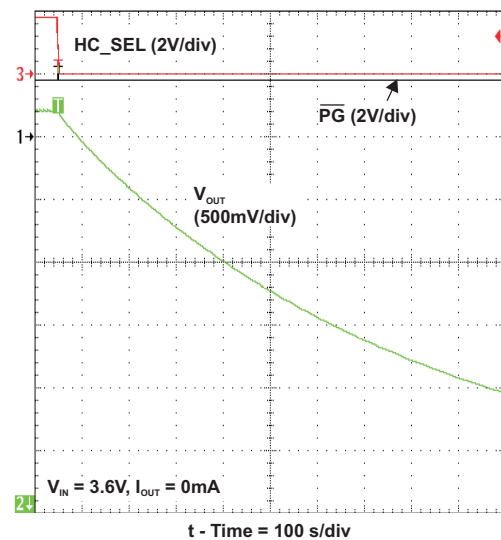

Figure 52. SHUTDOWN (HC_SEL=1)

DETAILED DESCRIPTION

OPERATION

The TPS6132x family employs a 2MHz fixed on-time, PWM current-mode converter to generate the output voltage required to drive up to three high power LEDs in parallel. The device integrates a power stage based on an NMOS switch and a synchronous PMOS rectifier. The device also implements a set of linear low-side current regulators to control the LED current when the battery voltage is higher than the diode forward voltage.

A special circuit is applied to disconnect the load from the battery during shutdown of the converter. In conventional synchronous rectifier circuits, the back-gate diode of the high-side PMOS is forward biased in shutdown and allows current flowing from the battery to the output. This device however uses a special circuit which takes the cathode of the back-gate diode of the high-side PMOS and disconnects it from the source when the regulator is in shutdown (HC_SEL = L).

The TPS6132x device cannot only operate as a regulated current source but also as a standard voltage boost regulator featuring power-save mode for improved efficiency at light load. Voltage mode operation can be enabled/disabled by software control.

The TPS6132x device also supports storage capacitor on its output (so called energy storage mode). In this operating mode (HC_SEL = H), the inductive power stage is used to charge-up the super-capacitor to a user selectable value. Once the charge-up is complete, the LEDs can be fired up to 1025mA (LED1 and LED3) and 2050mA (LED2) without causing a battery overload.

In general, a boost converter only regulates output voltages which are higher than the input voltage. This device operates differently. For example, in the voltage mode operation the device is capable to regulate 4.2V at the output from a battery voltage pulsing as high 5.5V. To control these applications properly, a down conversion mode is implemented.

If the input voltage reaches or exceeds the output voltage, the converter changes to a down conversion mode. In this mode, the control circuit changes the behavior of the rectifying PMOS. It sets the voltage drop across the PMOS as high as needed to regulate the output voltage. This means the power losses in the converter increase. This has to be taken into account for thermal consideration.

In direct drive mode (HC_SEL = L), the power stage is capable of supplying a maximum total current of roughly 1300 to 1500mA. The TPS6132x provides three constant current inputs, capable of sinking up to 445mA (LED1 and LED3) and 890mA (LED2) in flashlight mode.

The TPS6132x integrates an I²C compatible interface allowing transfers up to 3.4Mbits/s. This communication interface can be used to set the operating mode (shutdown, constant output current mode vs. constant output voltage mode), to control the brightness of the external LED (DC light and flashlight modes), to adjust the output voltage (between 3.825V and 5.7V in 125mV steps) or to program the safety timer for instance. For more details, refer to the I²C register description section.

In the TPS6132x device, the DC light and flash can be controlled either by the I²C interface or by the means of hardware control signals (STRB0 and STRB1). The maximum duration of the flashlight pulse can be limited by means of an internal user programmable safety timer (STIM). To avoid the LEDs to be kept accidentally on in DC light mode by software control, the device implements a 13.0s watchdog timer. The DC light watchdog timer can be disabled by pulling high the STRB1 signal.

DOWN MODE IN VOLTAGE REGULATION MODE

In general, a boost converter only regulates output voltages which are higher than the input voltage. The featured devices come with the ability to regulate 4.2 V at the output with an input voltage being as high as 5.5V. To control these applications properly, a down conversion mode is implemented.

In voltage regulation mode, if the input voltage reaches or exceeds the output voltage, the converter changes to the down-conversion mode. In this mode, the control circuit changes the behavior of the rectifying PMOS. It sets the voltage drop across the PMOS as high as needed to regulate the output voltage. This means the power losses in the converter increase. This has to be taken into account for thermal consideration. The down conversion mode is automatically turned-off as soon as the input voltage falls about 200mV below the output voltage.

For proper operation in down conversion mode the output voltage should not be programmed higher than ca. 5.3V. Care should be taken not to violate the absolute maximum ratings at the SW pins.

The TPS6132x device uses a control architecture that allows to “recycle” excessive energy that might be stored in the output capacitor. By reversing the operation of the boost power stage, the converter is capable of transferring energy from its output back into the input source.

In high-current mode (HC_SEL = 1), this feature becomes useful to dynamically adjust the output voltage (V_{OUT}) depending on the operating conditions (e.g. +4.95V constant output voltage to support audio applications or variable storage capacitor pre-charge voltage, refer to “storage capacitor pre-charge voltage calibration” section).

Notice that this reverse operating mode can only perform within an output voltage range higher than the input supply. For example, if the storage capacitor is initially pre-charged to 4.95V, the input voltage is around 4.1V and the target output voltage is set to 3.825V, the converter will only be able to lower the output node down to the input level.

LED HIGH-CURRENT REGULATORS, UNUSED INPUTS

The TPS6132x device utilizes LED forward voltage sensing circuitry on LED1-3 pins to optimize the power stage boost ratio for maximum efficiency. Due to the nature of the sensing circuitry, it is not recommended to leave any of the LED1-3 pins unused if the operation has been selected via ENLED[3:1] bits. Leaving LED1-3 pins unconnected, whilst the respective ENLEDx bits have been set, will force the control loop into high gain and eventually trip the output over-voltage protection.

The LED1-3 inputs may be connected together to drive one or two LEDs at higher currents. Connecting the current sink inputs in parallel does not affect the internal operation of the TPS6132x. For best operation, it is recommended to disabled the LED inputs that are not used (refer to ENLED[3:1] bits description).

To achieve smooth LED current waveforms, the TPS6132x device actively controls the LED current ramp-up/down sequence.

Table 1. LED Current Ramp-Up/Down Control vs Operating Mode

	DIRECT DRIVE MODE (HC_SEL = 0)	HIGH-CURRENT MODE (HC_SEL = 1)
LED CURRENT RAMP-UP	$I_{STEP} = 27.5 \text{ mA}$	$I_{STEP} = 62 \text{ mA}$
	$t_{RISE} = 12 \text{ }\mu\text{s}$	$t_{RISE} = 0.5 \text{ }\mu\text{s}$
	Slew-rate $\approx 2.3 \text{ mA}/\mu\text{s}$	Slew-rate $\approx 124 \text{ mA}/\mu\text{s}$
LED CURRENT RAMP-DOWN	$I_{STEP} = 27.5 \text{ mA}$	$I_{STEP} = 62 \text{ mA}$
	$t_{FALL} = 0.5 \text{ }\mu\text{s}$	$t_{FALL} = 0.5 \text{ }\mu\text{s}$
	Slew-rate $\approx 55 \text{ mA}/\mu\text{s}$	Slew-rate $\approx 124 \text{ mA}/\mu\text{s}$

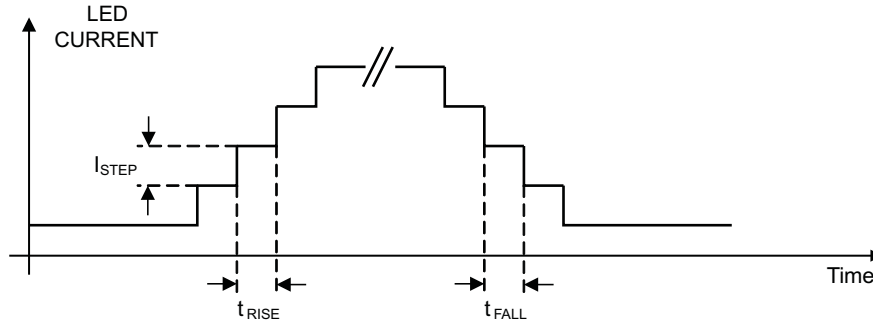

Figure 53. LED Current Slew-Rate Control

In high-current mode ($HC_SEL = 1$), the LED current settings are defined as a fixed ratio ($\times 2.25$) versus the direct drive mode values ($HC_SEL = L$).

POWER-SAVE MODE OPERATION, EFFICIENCY

The TPS6132x device integrates a power save mode to improve efficiency at light load. In power save mode the converter only operates when the output voltage trips below a set threshold voltage. It ramps up the output voltage with one or several pulses and goes again into power save mode once the output voltage exceeds the set threshold voltage.

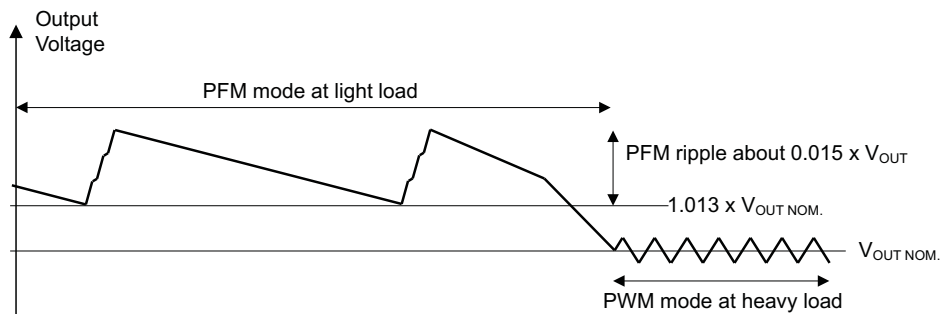

Figure 54. Operation in PFM Mode and Transfer to PWM Mode

The power save mode can be enabled and disabled via the ENPSM bit. In down conversion mode, power save mode is always active and the device cannot be forced into fixed frequency operation at light loads.

The LED sense voltage has a direct effect on the converter's efficiency. Because the voltage across the low-side current regulator does not contribute to the output power (LED brightness), the lower the sense voltage the higher the efficiency will be.

In direct drive mode ($HC_SEL = L$), the energy is being directly transferred from the battery to the LEDs. The integrated current control loop automatically selects the minimum boosting ratio to maintain regulation based on the LED forward voltage and current requirements. The low-side current regulators will be dropping the voltage difference between the input voltage and the LEDs forward voltage ($V_{F(LED)} < V_{IN}$). When running in boost mode ($V_{F(LED)} > V_{IN}$), the voltage present at the LED1-3 pins of the low-side current regulators will be typically 400mV leading to high power conversion efficiency. Depending on the input voltage and the LEDs forward voltage characteristic the converter will show efficiency in the range of about 75% to 90%.

In high-current mode ($HC_SEL = H$), the device is only supplying a limited amount of energy directly from the battery (i.e. DC light, contribution to flash current or voltage regulation mode). During a flash strobe, the bulk of the energy supplied to the LEDs is provided by the reservoir capacitor. The low-side current regulators will be typically operating with 400mV headroom voltage. This means the power losses in the device increase and special care should be taken for thermal considerations.

MODE OF OPERATION: DC LIGHT AND FLASHLIGHT

Operation is understood best by referring to the timer block diagram. Depending on the settings of MODE_CTRL[1:0] bits the device can enter 4 different operating modes.

- MODE_CTRL[1:0] = 00: The device is in shutdown mode.
- MODE_CTRL[1:0] = 01: The STRB0, STRB1 inputs are disabled. The device is regulating the LED current in DC light mode (DCLC bits) regardless of the STRB0, STRB1 inputs and the START_FLASH/TIMER (SFT) bit. To avoid device shutdown by DC light safety timeout, MODE_CTRL[1:0] needs to be refreshed within less than 13.0s (STRB1 = 0). The DC light watchdog timer can be disabled by pulling high the STRB1 signal.
- MODE_CTRL[1:0] = 10: The STRB0, STRB1 inputs are enabled and the flashlight pulse can either be triggered by these synchronization signals or by a software command (START_FLASH/TIMER (SFT) bit, STRB0 = 1). The LEDs operation is enabled/disabled according to the STRB0, STRB1 input, the flashlight safety timer is activated and the DC light safety timer is disabled.
- MODE_CTRL[1:0] = 11: The device is regulating a constant output voltage according to OV[3:0] bits settings. The low-side LED1-3 current regulators are disabled and the LEDs are disconnected from the output. In this operating mode, the safety timer is disabled.

FLASH STROBE IS LEVEL SENSITIVE (STT = 0): LED STROBE FOLLOWS STRB0, 1 INPUTS

In this mode, the high-power LEDs are driven at the flashlight current level and the safety timer (STIM) is running. The maximum duration of the flashlight pulse is defined in the STIM[2:0] register.

The safety timer is triggered on rising edge and stopped either by a negative logic on the synchronization source (STRB0, STRB1 = 0) or by a timeout event (TO bit).

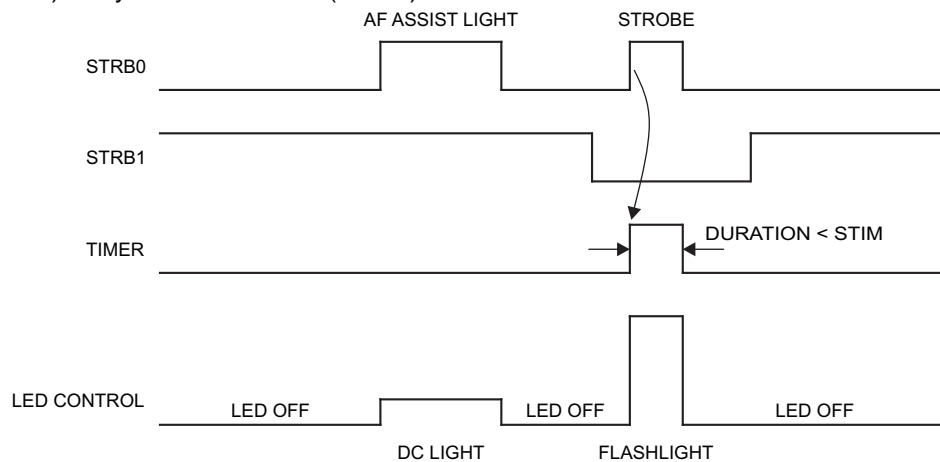

Figure 55. Hardware Synchronized DC Light and Flashlight Strobe

FLASH STROBE IS LEADING EDGE SENSITIVE (STT = 1): ONE-SHOT LED STROBE

In this mode, the high-power LEDs are driven at the flashlight current level and the safety timer (STIM) is running. The duration of the flashlight pulse is defined in the STIM[2:0] register.

The flashlight strobe is started either by a rising edge on the synchronization source (STRB0 = 1, STRB1 = 0) or by a positive transition on the START-FLASH/TIMER (SFT) bit (STRB0 = 1, STRB1 = 0). Once running, the timer ignores all kind of triggering signals and only stops after a timeout (TO). START-FLASH/TIMER (SFT) bit is being reset by the timeout (TO) signal.

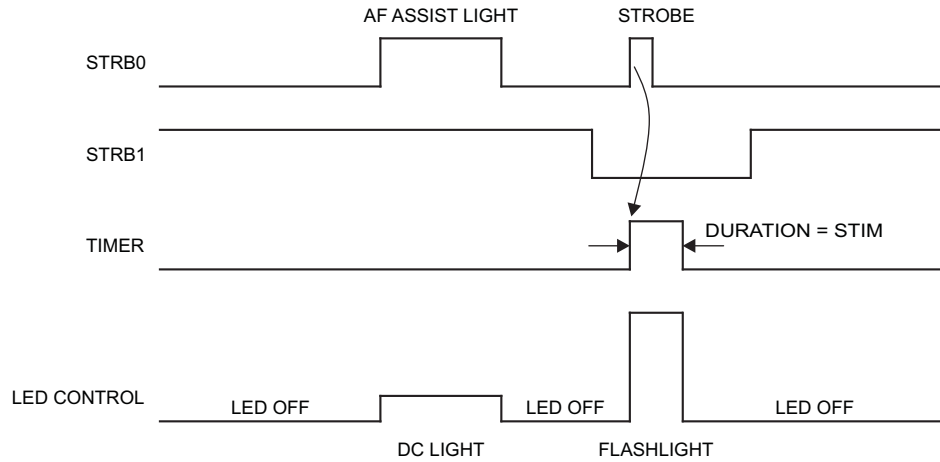

Figure 56. Edge Sensitive Timer (Single Trigger Event)

SAFETY TIMER ACCURACY

The LED strobe timer uses the internal oscillator as reference clock. As a matter of fact, the timer execution speed (refer to STIM[2:0]) scales according to the reference clock accuracy.

OSCILLATOR FREQUENCY	SAFETY TIMER DURATION
Minimum	Maximum = Typical × (1 + f _{ACC}) ⁽¹⁾
Typical	Typical ⁽²⁾
Maximum	Minimum = Typical × (1 - f _{ACC}) ⁽¹⁾

(1) Refer to REGISTER3, STIM[2:0] definition.
 (2) Refer to the Electrical Characteristics table.

CURRENT LIMIT OPERATION

The current limit circuit employs a valley current sensing scheme. Current limit detection occurs during the off time through sensing of the voltage drop across the synchronous rectifier. The detection threshold is user selectable via the ILIM bit. The ILIM bit can only be set before the device enters operation (i.e., initial shutdown state).

Figure 57 illustrates the inductor and rectifier current waveforms during current limit operation. The output current, I_{OUT} , is the average of the rectifier ripple current waveform. When the load current is increased such that the lower peak is above the current limit threshold, the off time is lengthened to allow the current to decrease to this threshold before the next on-time begins (so called frequency fold-back mechanism).

Both the output voltage and the switching frequency are reduced as the power stage of the device operates in a constant current mode. The maximum continuous output current ($I_{OUT(CL)}$), before entering current limit operation, can be defined as:

$$I_{OUT(CL)} = (1 - D) \times (I_{VALLEY} + \frac{1}{2} \Delta I_L) \text{ with } \Delta I_L = \frac{V_{IN}}{L} \times \frac{D}{f} \text{ and } D \approx \frac{V_{OUT} - V_{IN}}{V_{OUT}} \quad (1)$$

The TPS6132x device also provides a negative current limit (c.a. 300mA) to prevent an excessive reverse inductor current when the power stage sinks current from the output (i.e., storage capacitor) in the forced continuous conduction mode.

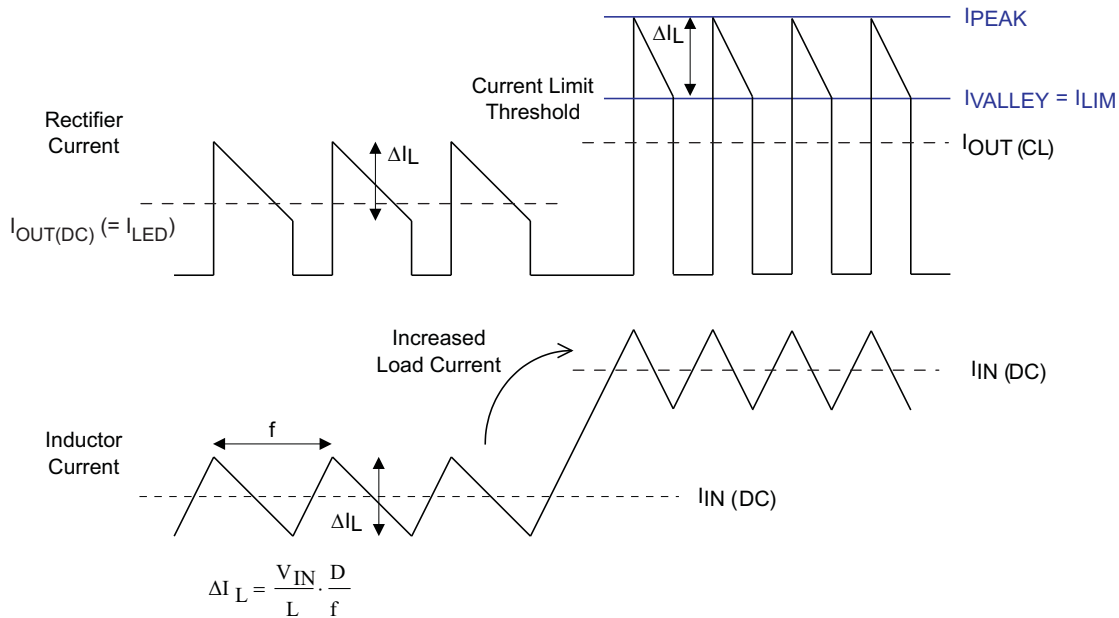

Figure 57. Inductor/Rectifier Currents in Current Limit Operation

To minimize the requirements on the energy storage capacitor present at the output of the driver ($HC_SEL = 1$), the TPS6132x device can contribute to a larger extent in supporting directly the high-current LED flash strobe. In fact, the device can dynamically adjust its current limit setting according to the Tx-MASK input.

Table 2. Inductor Current Limit Operation vs HC_SEL/Tx-MASK Inputs

VALLEY CURRENT LIMIT SETTING	ILIM BIT	HC_SEL INPUT	Tx-MASK INPUT
1150 mA	Low	Low	Low
1600 mA	High	Low	Low
30 mA	Low	High	Low
250 mA	High	High	Low
1150 mA	Low	Low	High
1600 mA	High	Low	High
n/a ⁽¹⁾	Low	High	High
n/a ⁽¹⁾	High	High	High

(1) The DC/DC power stage is disabled, zero current is being drained from the input source.

LED FAILURE MODES AND OVER-VOLTAGE PROTECTION

If a high-power LED fails as a short circuit, the low-side current regulator will limit the maximum output current and the HIGH-POWER LED FAILURE (HPLF) flag will be set.

If a high-power LED fails as an open circuit, the control loop will initially attempt to regulate off of its low-side current regulator feedback signal. This will drive V_{OUT} higher. As the open circuited LED will never accept its programmed current, V_{OUT} must be voltage-limited by means of a secondary control loop.

The TPS6132x device limits V_{OUT} according to the over-voltage protection settings (refer to OVP specification). In this failure mode, V_{OUT} is either limited to 4.65V (typ.) or 6.0V (typ.) and the HIGH-POWER LED FAILURE (HPLF) flag is set.

OVP THRESHOLD	OPERATING CONDITIONS
4.65 V typ	HC_SEL = L and 0000 ≤ OV[3:0] ≤ 0100
6.0 V typ	HC_SEL = H or 0101 ≤ OV[3:0] ≤ 1111

Refer to the section “LED High-Current Regulators, Unused inputs” for additional information.

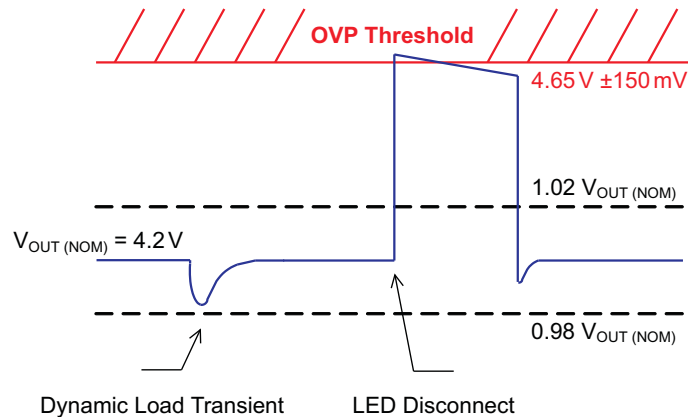

Figure 58. Over-Voltage Protection Operation (4.65V typ)

HARDWARE VOLTAGE MODE SELECTION

The TPS6132x device integrates a software control bit (ENVM bit) that can be used to force the converter to run in voltage mode regulation. [Table 3](#) gives an overview of the different mode of operation.

Table 3. Operating Mode Description

INTERNAL REGISTER SETTINGS MODE_CTRL[1:0]	ENVM BIT	OPERATING MODES
00	0	The converter is in shutdown mode and the load is disconnected from the battery.
01	0	LEDs are turned-on for DC light operation (i.e. movie-light). The converter is operating in the current regulation mode (CM). The output voltage is controlled by the forward voltage characteristic of the LED. The energy is being directly transferred from the battery to the output.
10	0	The converter is operating in the current regulation mode (CM). The output voltage is controlled by the forward voltage characteristic of the LED. LEDs are ready for flashlight operation supported directly from the battery. In high-current mode (HC_SEL = H), the energy is supplied by the output reservoir capacitor and the inductive power stage is turned-off for the flash strobe period of time.
11	0	LEDs are turned-off and the converter is operating in the voltage regulation mode (VM). The output voltage is set via the register OV[3:0].
00	1	LEDs are turned-off and the converter is operating in the voltage regulation mode (VM). The output voltage is set via the register OV[3:0].
01	1	The converter is operating in the voltage regulation mode (VM) and it's output voltage is set via the register OV[3:0]. The LEDs are turned-on for DC light operation and the energy is being directly transferred from the battery to the output. The LED currents are regulated by the means of the low-side current sinks.
10	1	The converter is operating in the voltage regulation mode (VM) and it's output voltage is set via the register OV[3:0]. The LED currents are regulated by the means of the low-side current sinks. The LEDs are ready for flashlight operation. In direct drive mode (HC_SEL = L), the energy is being directly transferred from the battery to the output. In high-current mode (HC_SEL = H), the energy is largely supplied by the output reservoir capacitor. Nonetheless, the inductive power stage is active thereby contributing to the flash power.
11	1	LEDs are turned-off and the converter is operating in the voltage regulation mode (VM). The output voltage is set via the register OV[3:0].

START-UP SEQUENCE

To avoid high inrush current during start-up, special care is taken to control the inrush current. When the device enables, the internal startup cycle starts with the first step, the pre-charge phase.

During pre-charge, the rectifying switch is turned on until the output capacitor is either charged to a value close to the input voltage or ca. 3.3V, whichever occurs first. The rectifying switch is current limited during that phase. The current limit increases with decreasing input to output voltage difference. This circuit also limits the output current under short-circuit conditions at the output. [Figure 59](#) shows the typical pre-charge current vs. input minus the output voltage for a specific input voltage.

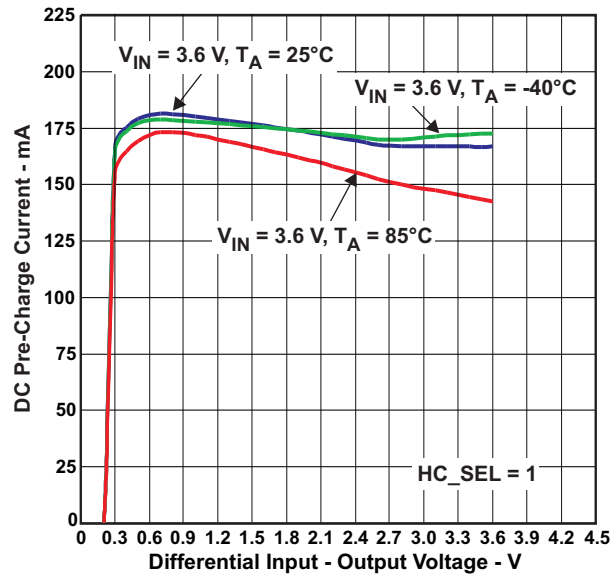

Figure 59. Typical DC Pre-charge and Short-Circuit Current

In direct drive mode ($HC_SEL = L$, TPS6132x), after having pre-charged the output capacitor, the device starts-up switching and increases its current limit in three steps of typically 30mA, 250mA and full current limit (ILIM setting). The current limit transitions from the first to the second step occurs after a milli-second operation. Full current limit operation is set once the output voltage has reached its regulation limits. In this mode, the active balancing circuit is disabled.

In high-current mode ($HC_SEL = H$), the pre-charge voltage of the storage capacitor is depending on the input voltage and operating mode (i.e., voltage regulation vs. current regulation mode). In case the device is set for exclusive current regulation operation (i.e., $MODE_CTRL[1:0] = 01$ or 10 and $ENVM = 0$), the output capacitor pre-charge voltage will be close to the input voltage. Under all other operating conditions, the pre-charge voltage will either be close to the input voltage or to approximately 3.3V, whichever is lower. Furthermore, pre-charge operation can be suspended/resumed via the Tx-MASK input (refer to ILIM setting and Tx-MASK input logic state).

After having pre-charged the storage capacitor, the device starts-up switching. During down-mode operation, the inductor valley current is actively limited either to 30mA or 250mA (refer to ILIM setting). As the device enters boost mode operation, the current limit transitions to its full capability (refer to ILIM setting and Tx-MASK input logic state). As a consequence, the output voltage ramps-up linearly and the start-up time needed to reach the programmed output voltage (refer to $OV[3:0]$ bits) will mainly depend on the super-capacitor value and load current. In this mode, the active balancing circuit is enabled.

POWER GOOD (FLASH READY)

The TPS6132x integrates a power good circuitry that is activated when the device is operating in voltage regulation mode (MODE_CTRL[1:0] = 11 or ENVM = 1). In shutdown mode (MODE_CTRL[1:0] = 00) the GPIO/PG pin state is defined as following:

GPIOTYPE	GPIO/PG SHUTDOWN STATE
0	Reset/pulled to ground
1	Open-drain

Depending on the GPIO/PG output stage type selection (i.e., push-pull or open-drain), the polarity of the power-good output signal (PG) can be inverted or not. The power-good software bit and hardware signal polarity is defined as following:

GPIOTYPE	PG BIT	GPIO/PG OUTPUT PORT	COMMENTS
0: push-pull output	0	0	Output is active high signal polarity
	1	1	
1: open-drain output	0	Open-drain	Output is active low signal polarity
	1	Low	

The power good signal is valid when the output voltage is within -1.5% and $+2.5\%$ of its nominal value. Conversely, it is asserted low when the voltage mode operation gets suspended (MODE_CTRL[1:0] \neq 11 and ENVM = 0).

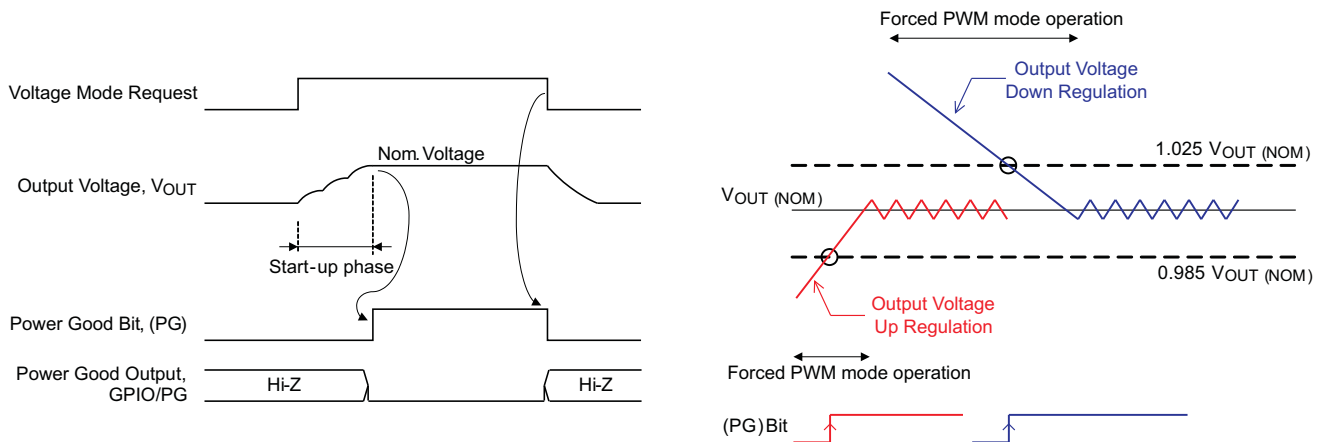

Figure 60. Power Good Operation (DIR = 1, GPIOTYPE = 1)

The TPS6132x device uses a control architecture that allows to “recycle” excessive energy that might be stored in the output capacitor. By reversing the operation of the boost power stage, the converter is capable of transferring energy from its output back into the input source. In this case, the power good signal is de-asserted whilst the output voltage is decreasing towards its target value (i.e., the closest fit voltage the converter can support, refer to the section “Down-Mode in Voltage Regulation Mode” for additional information).

LED TEMPERATURE MONITORING

The TPS6132x devices monitor the LED temperature by measuring the voltage between the TS and AGND pins. An internal current source provides the bias (c.a. 24 μ A) for a negative-temperature coefficient resistor (NTC), and the TS pin voltage is compared to internal thresholds (1.05V and 0.345V) to protect the LEDs against overheating.

The temperature monitoring related blocks are always active in DC light or flashlight modes. In voltage mode operation (MODE_CTRL[1:0] = 11), the device only activates the TS input when the ENTS bit is set to high. In shutdown mode, the LED temperature supervision is disabled and the quiescent current of the device is dramatically reduced.

The LEDWARN and LEDHOT bits reflect the LED temperature. The LEDWARN bit is set when the voltage seen at the TS pin is lower than 1.05V. This threshold corresponds to an LED warning temperature value, the device operation is still permitted.

While regulating LED current (i.e., DC light or flashlight modes), the LEDHOT bit is latched when the voltage seen at the TS pin is lower than 0.345V. This threshold corresponds to an excessive LED temperature value, the device operation is immediately suspended (MODE_CTRL[1:0] bits are reset and HOTDIE[1:0] bits are set).

HOT DIE DETECTOR

The hot die detector monitors the junction temperature but does not shutdown the device. It provides an early warning to the camera engine to avoid excessive power dissipation thus preventing from thermal shutdown during the next high-power flash strobe.

The hot die detector (HOTDIE[1:0] bits) reflects the instantaneous junction temperature and is always enabled excepted when the device is in shutdown mode (MODE_CTRL[1:0] = 00).

FLASHLIGHT BLANKING (Tx-MASK)

In direct drive mode (HC_SEL = 0), the Tx-MASK input signal can be used to disable the flashlight operation, e.g., during a RF PA transmission pulse. This blanking function turns the LED from flashlight to DC light thereby reducing almost instantaneously the peak current loading from the battery. The Tx-MASK function has no influence on the safety timer duration.

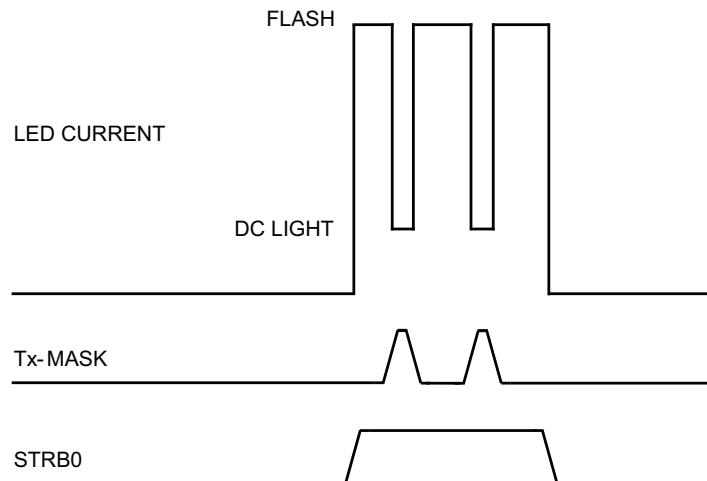

Figure 61. Synchronized Flashlight With Blanking Periods (STRB1 = 0)

In high-current mode (HC_SEL = 1), the Tx-MASK input pin is also used to dynamically adjust the device's current limit setting (i.e. controls the maximum current drawn from the input source). Refer to the section "Current Limit Operation" for additional information.

UNDERVOLTAGE LOCKOUT

The under-voltage lockout circuit prevents the device from mis-operation at low input voltages. It prevents the converter from turning on the switch–MOSFET, or rectifier–MOSFET for battery voltages below 2.3V. The I2C compatible interface is fully functional down to 2.1V input voltage.

SHUTDOWN

MODE_CTRL[1:0] bits low force the device into shutdown. The shutdown state can only be entered when voltage regulation is turned-off (ENVM = 0).

In direct drive mode (HC_SEL = L), the regulator stops switching, the high-side PMOS disconnects the load from the input and the LEDx pins are high impedance thus eliminating any DC conduction path. The TPS6132x device actively discharges the output capacitor when it turns off.

The integrated discharge resistor has a typical resistance of 2k Ω equally split-off between VOUT to BAL and BAL to GND outputs. The required time to discharge the output capacitor at V_{OUT} depends on load current and the effective output capacitance. The active balancing circuit is disabled and the device consumes only a shutdown current of 1 μ A (typ).

In high-current mode (HC_SEL = H), the device maintains its output biased at the input voltage level. In this mode, the synchronous rectifier is current limited (i.e. pre-charge current) allowing external load (e.g. audio amplifier) to be powered with a restricted supply. The active balancing circuit is enabled and the device consumes only a standby current of 5 μ A (typ).

THERMAL SHUTDOWN

As soon as the junction temperature, T_J, exceeds 160°C typical, the device goes into thermal shutdown. In this mode, the power stage and the low-side current regulators are turned-off, the HOTDIE[1:0] bits are set and can only be reset by a readout.

In the voltage mode operation (MODE_CTRL[1:0] = 11 or ENVM = 1), the device continues its operation when the junction temperature falls below 140°C typ. again. In the current regulation mode (i.e., DC light or flashlight modes) the device operation is suspended.

STORAGE CAPACITOR ACTIVE CELL BALANCING

A fully charged super-capacitor will typically have leakage current of under 1 μ A. The TPS6132x device integrates an active balancing feature to cut the total leakage current from the super-capacitor and balance circuit to less than 1.7 μ A typ.

The device integrates a window comparator monitoring the tap point of the multi-cell super-capacitor. The balancing output (BAL) is substantially half the actual output voltage (V_{OUT}). If the internal leakage current in one of the capacitors is larger than that in the other, then the voltage at their junction will tend to change in such a way that the voltage on the capacitor with the larger (or largest) leakage current will reduce.

When this happens, a current will begin to flow from the BAL output in such a direction as to reduce the amount by which the voltage changes. The current that will flow after a long period of steady-state conditions will be approximately equal to the difference between the leakage currents of the pair of capacitors which is being balanced by the circuit. The output resistance of the balancing circuit (c.a. 250 Ω) determines how quickly an imbalance will be corrected.

RED LIGHT PRIVACY INDICATOR

The TPS6132x device provides a high-side linear constant current source to drive low VF LEDs. The LED current is directly regulated off the battery and can be controlled via the INDC[3:0] bits. Operation is understood best by referring to the [Figure 62](#) and [Figure 63](#).

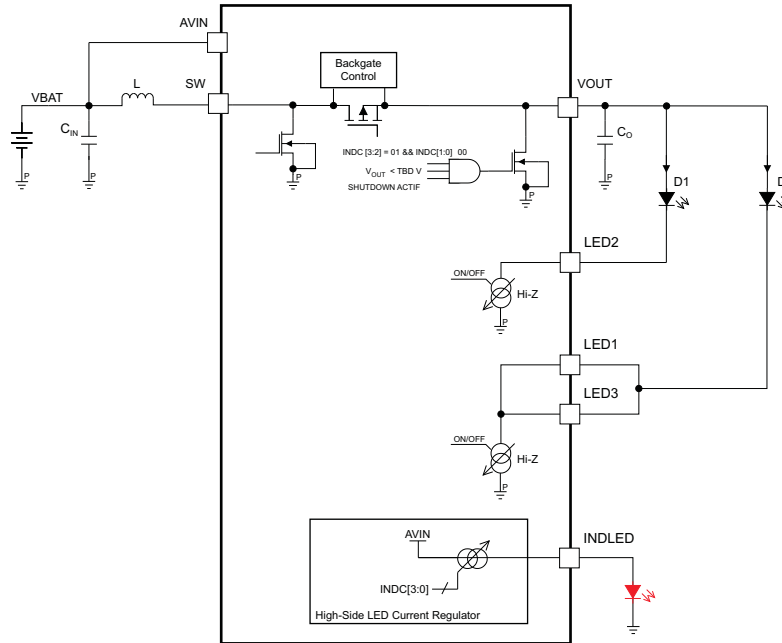

Figure 62. RED Light Indicator, Configuration 1

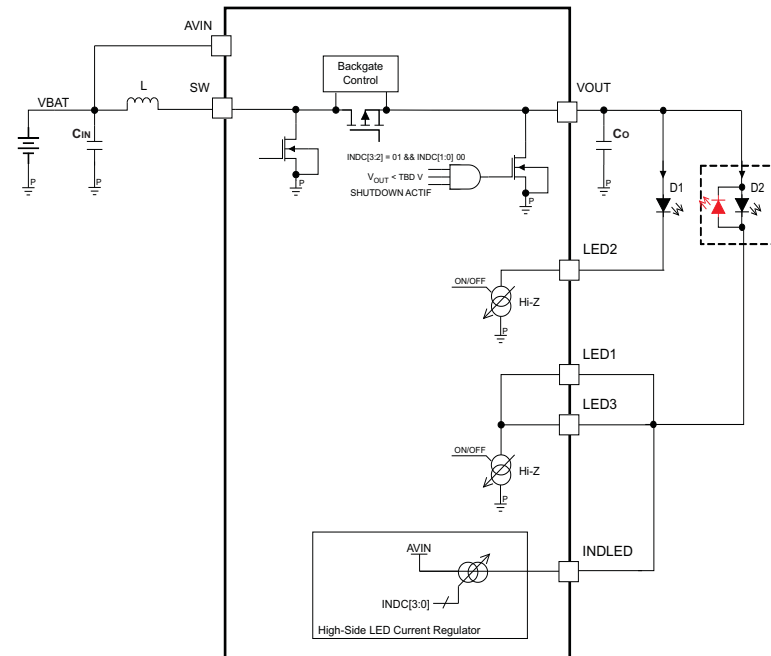

Figure 63. RED Light Indicator, Configuration 2

The device can provide a path to allow for reverse biasing of white LEDs (refer to [Figure 63](#)). To do so, the output of the converter (VOUT) is pulled to ground thus allowing a reverse current to flow. This mode of operation is only possible when the converter's power stage is in shutdown (MODE_CTRL[1:0] = 00, ENVNVM = 0 and HC_SEL = 0).

WHITE LED PRIVACY INDICATOR

The TPS6132x device features white LED drive capability at low light intensity. To generate a reduced LED average current, the device employs a 30kHz fixed frequency PWM modulation scheme. The PWM timer uses the internal oscillator as reference clock, therefore the PWM modulating frequency shows the same accuracy as the internal reference clock. Operation is understood best by referring to the timer block diagram.

The DC light current is modulated with a duty cycle defined by the INDC[3:0] bits. The low light dimming mode can only be activated in the software controlled DC light only mode (MODE_CTRL[1:0] = 01, ENVNVM = 1) and applies to the LEDs selected via ENLED[3:1] bits. In this mode, the DC light safety timeout feature is disabled.

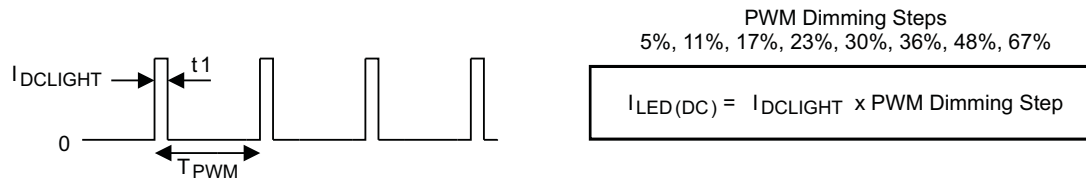

Figure 64. PWM Dimming Principle

STORAGE CAPACITOR, PRE-CHARGE VOLTAGE CALIBRATION

High-power LEDs tend to exhibit a wide forward voltage distribution. The TPS6132x device integrates a self-calibration procedure that can be used to determine the optimum super-capacitor pre-charge voltage based on the actual worst case LED forward voltage and ESR of the storage capacitor. This calibration procedure is meant to start-off at a min. output voltage and can be initiated by setting the SELFCAL bit (preferably with MODE_CTRL[1:0] = 00, ENVNVM = 0).

The calibration procedure monitors the sense voltage across the low-side current regulators (according to ENLED[3:1] bits setting) and registers the worst case LED (i.e. the LED featuring the largest forward voltage). The TPS6132x device automatically sweeps through its output voltage range and performs a short duration flash strobe for each step (refer to FC13[1:0] and FC2[2:0] bits settings).

In direct drive mode (HC_SEL = L), the energy is being directly transferred from the battery to the LEDs. In high-current mode (HC_SEL = H), the energy is supplied exclusively by the output reservoir capacitor and the inductive power stage is turned-off for the flash strobe period of time.

The sequence is stopped as soon as the device detects that each of the low-side current regulators have enough headroom voltage (i.e. 400mV typ.). The device returns the according output voltage in the register OV[3:0] and sets the SELFCAL bit. This bit is only being reset at the (re-)start of a calibration cycle. In other words, when SELFCAL is asserted the output voltage register (OV[3:0]) returns the result of the last calibration sequence.

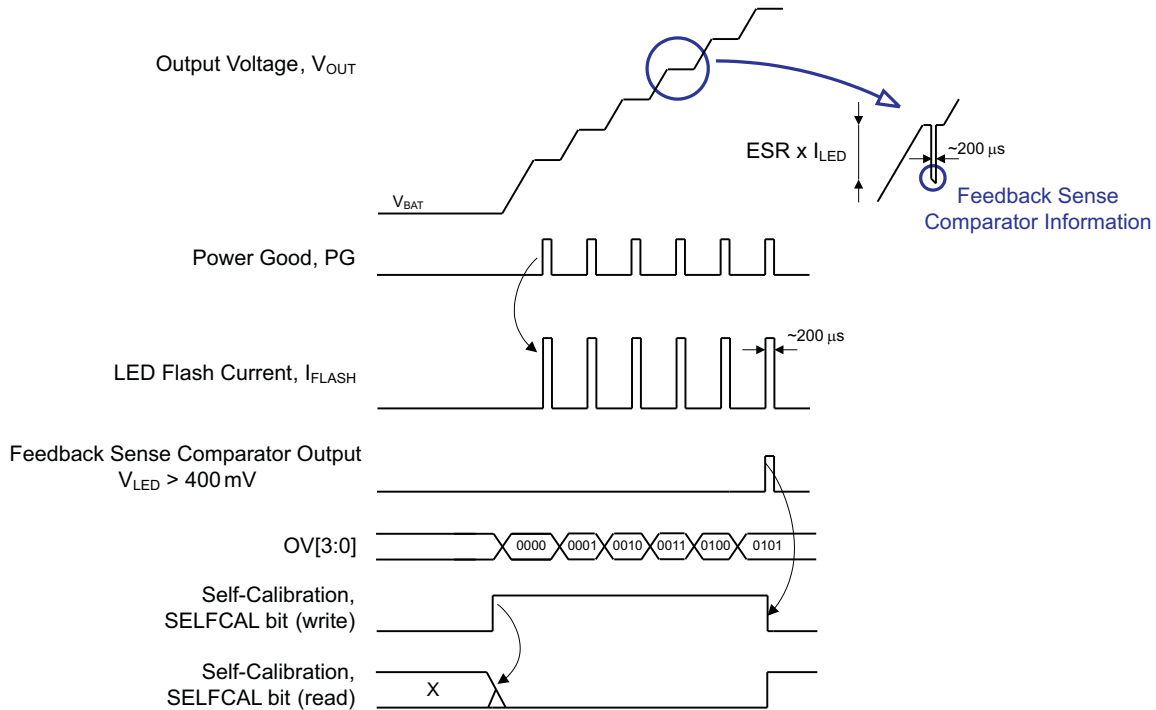

Figure 65. LED Forward Voltage Self-Calibration Principle

STORAGE CAPACITOR, ADAPTIVE PRE-CHARGE VOLTAGE

In high-power LED camera flash applications, the storage capacitor is supposed to be charged to an optimum voltage level in order to:

- Maintain sufficient headroom voltage across the LED current regulators for the entire strobe time.
- Minimize the power dissipation in the device.

High-power LEDs tend to exhibit large dynamic forward voltage variation relating to own self-heating effects. In addition, the energy storage capacitor (i.e., Electrochemical Double-Layer Capacitor or Super-Capacitor) also shows a relatively large effective capacitance and ESR spread. The main factors contributing to these variations are:

- Flash strobe duration
- Temperature
- Ageing effects

In practice, it normally becomes very challenging to compensate for all these variations and a worst-case design would presumably be too pessimistic. As a consequence, designers would have to give-up on the benefits coming along with the “Storage Capacitor, Pre-Charge Voltage Calibration” approach.

The TPS6132x device offers the possibility of controlling the storage capacitor pre-charge voltage in a closed-loop manner. The principle is to dynamically adjust the initial pre-voltage to the minimum value, as required for the particular components characteristic and operating conditions.

The reference criteria used to evaluate proper operation is the headroom voltage across the LED current regulators. In case of a critical headroom voltage (V_{LED1-3}) at the end of a flash strobe (i.e., n cycle), the pre-charge voltage should be increased prior to the next capture sequence (i.e., n+1 cycle).

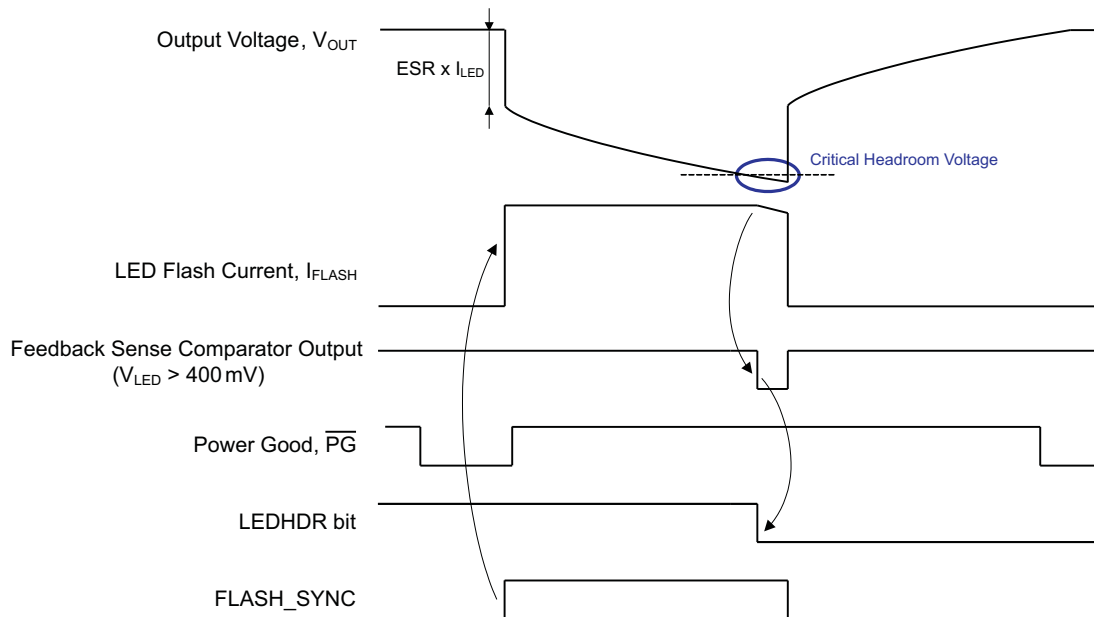

Figure 66. Storage Capacitor, Simple Adaptive Pre-Charge Voltage

SERIAL INTERFACE DESCRIPTION

I²C™ is a 2-wire serial interface developed by Philips Semiconductor, now NXP Semiconductors (see I²C-Bus Specification, Version 2.1, January 2000). The bus consists of a data line (SDA) and a clock line (SCL) with pull-up structures. When the bus is *idle*, both SDA and SCL lines are pulled high. All the I²C compatible devices connect to the I²C bus through open drain I/O pins, SDA and SCL. A *master* device, usually a microcontroller or a digital signal processor, controls the bus. The master is responsible for generating the SCL signal and device addresses. The master also generates specific conditions that indicate the START and STOP of data transfer. A *slave* device receives and/or transmits data on the bus under control of the master device.

The TPS6132x device works as a *slave* and supports the following data transfer *modes*, as defined in the I²C-Bus Specification: standard mode (100 kbps) and fast mode (400 kbps), and high-speed mode (3.4 Mbps). The interface adds flexibility to the power supply solution, enabling most functions to be programmed to new values depending on the instantaneous application requirements. Register contents remain intact as long as supply voltage remains above 2.1V.

The data transfer protocol for standard and fast modes is exactly the same, therefore they are referred to as F/S-mode in this document. The protocol for high-speed mode is different from F/S-mode, and it is referred to as HS-mode. The TPS6132x device supports 7-bit addressing; 10-bit addressing and general call address are not supported. The device 7bit address is defined as '011 0011' (TPS61325) and '011 0010' (TPS61326).

F/S-MODE PROTOCOL

The master initiates data transfer by generating a start condition. The start condition is when a high-to-low transition occurs on the SDA line while SCL is high, as shown in Figure 67. All I²C-compatible devices should recognize a start condition.

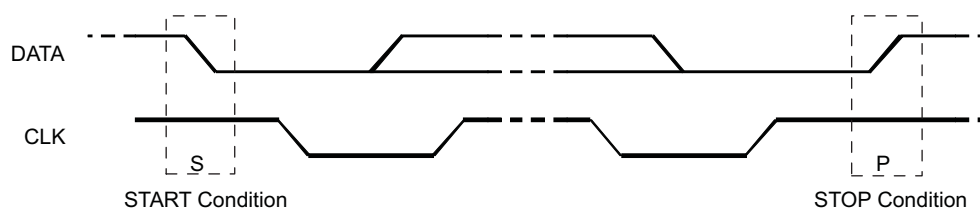

Figure 67. START and STOP Conditions

The master then generates the SCL pulses, and transmits the 7-bit address and the read/write direction bit R/W on the SDA line. During all transmissions, the master ensures that data is valid. A valid data condition requires the SDA line to be stable during the entire high period of the clock pulse (see Figure 68). All devices recognize the address sent by the master and compare it to their internal fixed addresses. Only the slave device with a matching address generates an acknowledge (see Figure 69) by pulling the SDA line low during the entire high period of the ninth SCL cycle. Upon detecting this acknowledge, the master knows that communication link with a slave has been established.

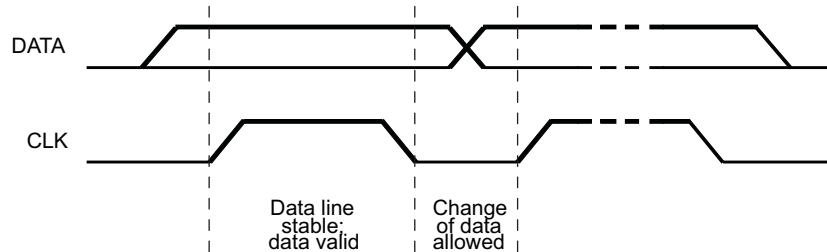

Figure 68. Bit Transfer on the Serial Interface

The master generates further SCL cycles to either transmit data to the slave (R/W bit 1) or receive data from the slave (R/W bit 0). In either case, the receiver needs to acknowledge the data sent by the transmitter. So an acknowledge signal can either be generated by the master or by the slave, depending on which one is the receiver. 9-bit valid data sequences consisting of 8-bit data and 1-bit acknowledge can continue as long as necessary.

To signal the end of the data transfer, the master generates a stop condition by pulling the SDA line from low to high while the SCL line is high (see Figure 67). This releases the bus and stops the communication link with the addressed slave. All I²C compatible devices must recognize the stop condition. Upon the receipt of a stop condition, all devices know that the bus is released, and they wait for a start condition followed by a matching address.

Attempting to read data from register addresses not listed in this section will result in 00h being read out.

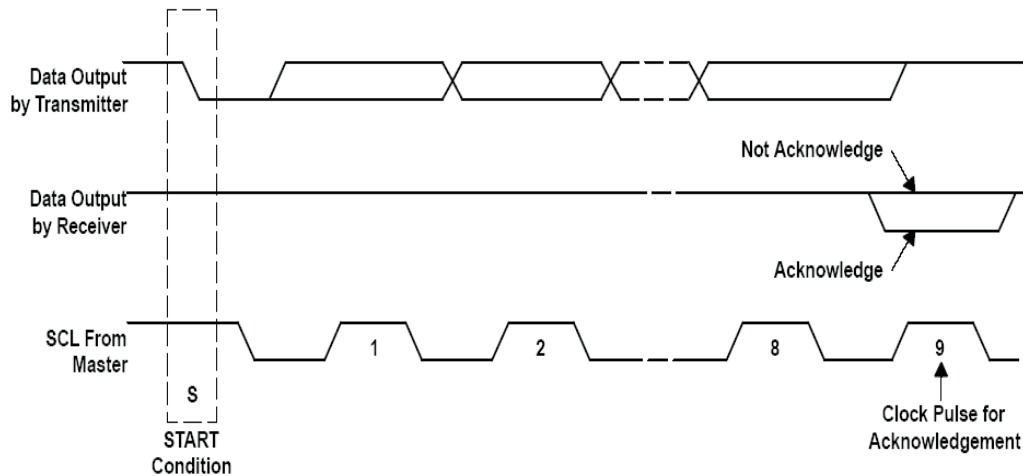

Figure 69. Acknowledge on the I²C Bus

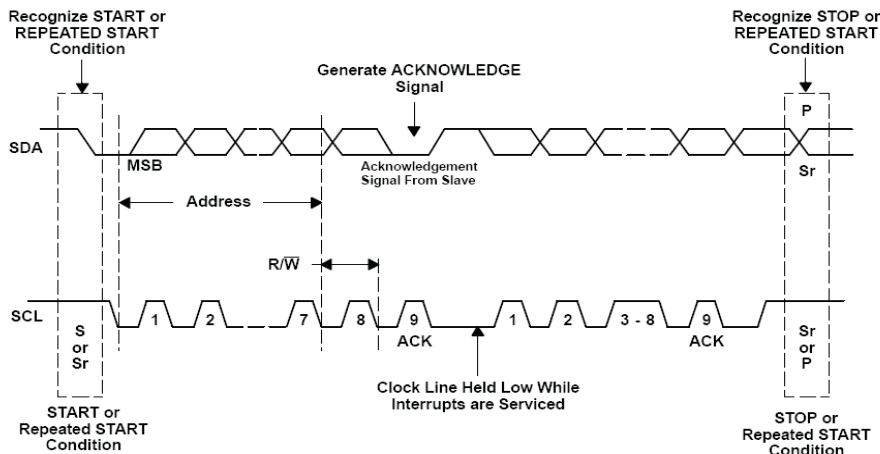

Figure 70. Bus Protocol

HS-MODE PROTOCOL

The master generates a start condition followed by a valid serial byte containing HS master code 00001XXX. This transmission is made in F/S-mode at no more than 400 Kbps. No device is allowed to acknowledge the HS master code, but all devices must recognize it and switch their internal setting to support 3.4 Mbps operation.

The master then generates a *repeated start condition* (a repeated start condition has the same timing as the start condition). After this repeated start condition, the protocol is the same as F/S-mode, except that transmission speeds up to 3.4 Mbps are allowed. A stop condition ends the HS-mode and switches all the internal settings of the slave devices to support the F/S-mode. Instead of using a stop condition, repeated start conditions should be used to secure the bus in HS-mode.

Attempting to read data from register addresses not listed in this section will result in 00h being read out.

TPS6132x I2C UPDATE SEQUENCE

The TPS6132x requires a start condition, a valid I²C address, a register address byte, and a data byte for a single update. After the receipt of each byte, TPS6132x device acknowledges by pulling the SDA line low during the high period of a single clock pulse. A valid I²C address selects the TPS6132x. TPS6132x performs an update on the falling edge of the acknowledge signal that follows the LSB byte.

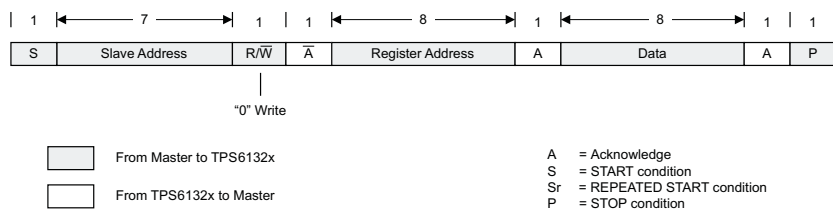

Figure 71. : "Write" Data Transfer Format in F/S-Mode

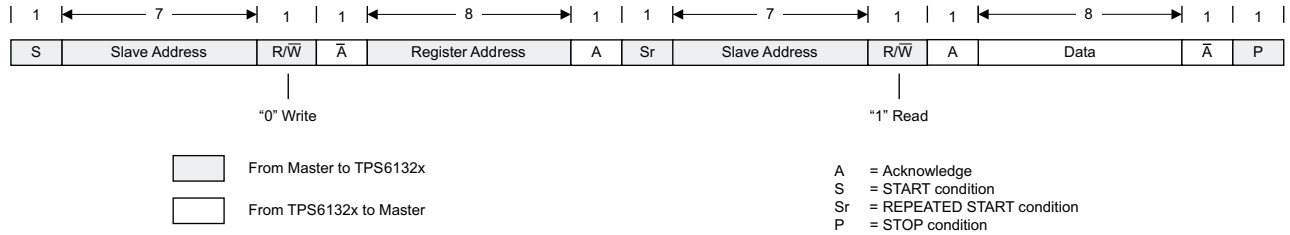

Figure 72. “Read” Data Transfer Format in F/S-Mode

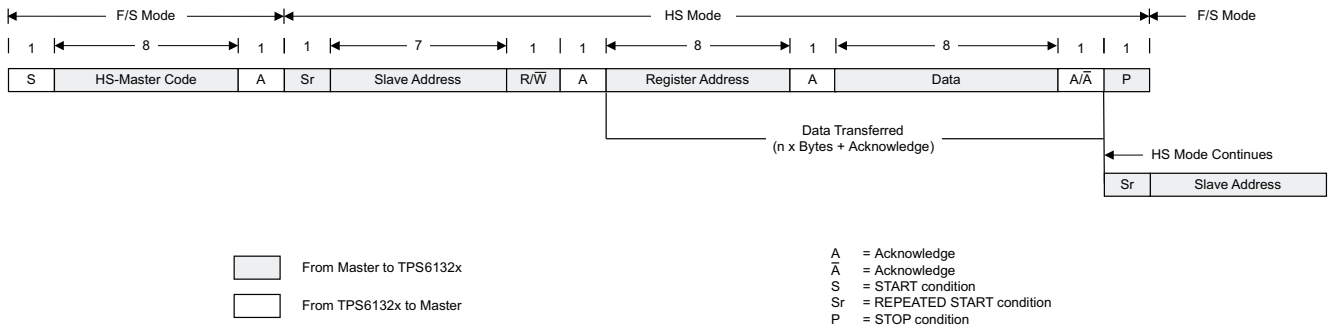

Figure 73. Data Transfer Format in H/S-Mode

SLAVE ADDRESS BYTE

MSB								LSB
X	X	X	X	X	X	A1	A0	

The slave address byte is the first byte received following the START condition from the master device.

REGISTER ADDRESS BYTE

MSB								LSB
0	0	0	0	00	D2	D1	D0	

Following the successful acknowledgement of the slave address, the bus master will send a byte to the TPS6132x, which will contain the address of the register to be accessed.

REGISTER0 DESCRIPTION

Memory location: 0x00

Description	RESET	FREE	DCLC13[2:0]			DCLC2[2:0]		
Bits	D7	D6	D5	D4	D3	D2	D1	D0
Memory type	R/W	R/W	R/W	R/W	R/W	R/W	R/W	R/W
Default value	0	0	0	0	1	0	1	0

Bit	Description
RESET	Register Reset bit. 0: Normal operation. 1: Default values are set to all internal registers.
DCLC13[2:0]	DC Light Current Control bits (LED1/3). 000: 0mA. ⁽¹⁾ ⁽²⁾ 001: 28.0mA 010: 55.75mA 011: 83.25mA 100: 111.0mA 101: 138.75mA 110: 166.5mA 111: 194.25mA
DCLC2[2:0]	DC Light Current Control bits (LED2). 000: 0mA. ⁽¹⁾ ⁽²⁾ 001: 28.0mA 010: 55.75mA 011: 83.25mA 100: 111.0mA 101: 138.75mA 110: 166.5mA, 249.75mA current level can be activated simultaneously with Tx-MASK = 1 111: 194.25mA, 360.75mA current level can be activated simultaneously with Tx-MASK = 1

(1) LEDs are off, V_{OUT} set according to OV[3:0].

(2) When DCLC2[2:0] and DCLC13[2:0] are both reset, the device operates in voltage regulation mode. The output voltage is set according to OV[3:0].

REGISTER1 DESCRIPTION

Memory location: 0x01

Description	MODE_CTRL[1:0]		FC2[5:0]					
	D7	D6	D5	D4	D3	D2	D1	D0
Bits								
Memory type	R/W	R/W	R/W	R/W	R/W	R/W	R/W	R/W
Default value	0	0	0	1	0	0	0	0

Bit	Description																																																																				
MODE_CTRL[1:0]	<p>Mode Control bits.</p> <p>00: Device in shutdown mode. 01: Device operates in DC light mode. 10: Device operates in flashlight mode. 11: Device operates as constant voltage source. To avoid device shutdown by DC light safety timeout, MODE_CTRL[1:0] bits need to be refreshed within less than 13.0s. Writing to REGISTER1[7:6] automatically updates REGISTER2[7:6].</p>																																																																				
FC2[5:0]	<p>Flash Current Control bits (LED2).</p> <table border="0"> <tr> <td>HC_SEL = 0</td> <td>HC_SEL = 1</td> </tr> <tr> <td>000000: 0mA. ^{(1) (2)}</td> <td>000000: 0mA. ^{(1) (2)}</td> </tr> <tr> <td>000001: 28.0mA</td> <td>000001: 64mA</td> </tr> <tr> <td>000010: 55.75mA</td> <td>000010: 130mA</td> </tr> <tr> <td>000011: 83.25mA</td> <td>000011: 196mA</td> </tr> <tr> <td>000100: 111.0mA</td> <td>000100: 260mA</td> </tr> <tr> <td>000101: 138.75mA</td> <td>000101: 324mA</td> </tr> <tr> <td>000110: 166.5mA</td> <td>000110: 388mA</td> </tr> <tr> <td>000111: 194.25mA</td> <td>000111: 452mA</td> </tr> <tr> <td>001000: 222.0mA</td> <td>001000: 516mA</td> </tr> <tr> <td>001001: 249.75mA</td> <td>001001: 580mA</td> </tr> <tr> <td>001010: 277.5mA</td> <td>001010: 644mA</td> </tr> <tr> <td>001011: 305.25mA</td> <td>001011: 708mA</td> </tr> <tr> <td>001100: 333.0mA</td> <td>001100: 772mA</td> </tr> <tr> <td>001101: 360.75mA</td> <td>001101: 836mA</td> </tr> <tr> <td>001110: 388.5mA</td> <td>001110: 900mA</td> </tr> <tr> <td>001111: 416.25mA</td> <td>001111: 964mA</td> </tr> <tr> <td>010000: 444.0mA</td> <td>010000: 1028mA</td> </tr> <tr> <td>010001: 471.75mA</td> <td>010001: 1092mA</td> </tr> <tr> <td>010010: 499.5mA</td> <td>010010: 1156mA</td> </tr> <tr> <td>010011: 527.25mA</td> <td>010011: 1220mA</td> </tr> <tr> <td>010100: 555.0mA</td> <td>010100: 1284mA</td> </tr> <tr> <td>010101: 582.75mA</td> <td>010101: 1348mA</td> </tr> <tr> <td>010110: 610.5mA</td> <td>010110: 1412mA</td> </tr> <tr> <td>010111: 638.25mA</td> <td>010111: 1476mA</td> </tr> <tr> <td>011000: 666.0mA</td> <td>011000: 1540mA</td> </tr> <tr> <td>011001: 693.75mA</td> <td>011001: 1604mA</td> </tr> <tr> <td>011010: 721.5mA</td> <td>011010: 1668mA</td> </tr> <tr> <td>011011: 749.25mA</td> <td>011011: 1732mA</td> </tr> <tr> <td>011100: 777.0mA</td> <td>011100: 1796mA</td> </tr> <tr> <td>011101: 804.75mA</td> <td>011101: 1860mA</td> </tr> <tr> <td>011110: 832.5mA</td> <td>011110: 1924mA</td> </tr> <tr> <td>011111: 860.25mA</td> <td>011111: 1988mA</td> </tr> <tr> <td>100000 ... 111111: 888.0mA</td> <td>100000 ... 111111: 2052mA</td> </tr> </table>	HC_SEL = 0	HC_SEL = 1	000000: 0mA. ^{(1) (2)}	000000: 0mA. ^{(1) (2)}	000001: 28.0mA	000001: 64mA	000010: 55.75mA	000010: 130mA	000011: 83.25mA	000011: 196mA	000100: 111.0mA	000100: 260mA	000101: 138.75mA	000101: 324mA	000110: 166.5mA	000110: 388mA	000111: 194.25mA	000111: 452mA	001000: 222.0mA	001000: 516mA	001001: 249.75mA	001001: 580mA	001010: 277.5mA	001010: 644mA	001011: 305.25mA	001011: 708mA	001100: 333.0mA	001100: 772mA	001101: 360.75mA	001101: 836mA	001110: 388.5mA	001110: 900mA	001111: 416.25mA	001111: 964mA	010000: 444.0mA	010000: 1028mA	010001: 471.75mA	010001: 1092mA	010010: 499.5mA	010010: 1156mA	010011: 527.25mA	010011: 1220mA	010100: 555.0mA	010100: 1284mA	010101: 582.75mA	010101: 1348mA	010110: 610.5mA	010110: 1412mA	010111: 638.25mA	010111: 1476mA	011000: 666.0mA	011000: 1540mA	011001: 693.75mA	011001: 1604mA	011010: 721.5mA	011010: 1668mA	011011: 749.25mA	011011: 1732mA	011100: 777.0mA	011100: 1796mA	011101: 804.75mA	011101: 1860mA	011110: 832.5mA	011110: 1924mA	011111: 860.25mA	011111: 1988mA	100000 ... 111111: 888.0mA	100000 ... 111111: 2052mA
HC_SEL = 0	HC_SEL = 1																																																																				
000000: 0mA. ^{(1) (2)}	000000: 0mA. ^{(1) (2)}																																																																				
000001: 28.0mA	000001: 64mA																																																																				
000010: 55.75mA	000010: 130mA																																																																				
000011: 83.25mA	000011: 196mA																																																																				
000100: 111.0mA	000100: 260mA																																																																				
000101: 138.75mA	000101: 324mA																																																																				
000110: 166.5mA	000110: 388mA																																																																				
000111: 194.25mA	000111: 452mA																																																																				
001000: 222.0mA	001000: 516mA																																																																				
001001: 249.75mA	001001: 580mA																																																																				
001010: 277.5mA	001010: 644mA																																																																				
001011: 305.25mA	001011: 708mA																																																																				
001100: 333.0mA	001100: 772mA																																																																				
001101: 360.75mA	001101: 836mA																																																																				
001110: 388.5mA	001110: 900mA																																																																				
001111: 416.25mA	001111: 964mA																																																																				
010000: 444.0mA	010000: 1028mA																																																																				
010001: 471.75mA	010001: 1092mA																																																																				
010010: 499.5mA	010010: 1156mA																																																																				
010011: 527.25mA	010011: 1220mA																																																																				
010100: 555.0mA	010100: 1284mA																																																																				
010101: 582.75mA	010101: 1348mA																																																																				
010110: 610.5mA	010110: 1412mA																																																																				
010111: 638.25mA	010111: 1476mA																																																																				
011000: 666.0mA	011000: 1540mA																																																																				
011001: 693.75mA	011001: 1604mA																																																																				
011010: 721.5mA	011010: 1668mA																																																																				
011011: 749.25mA	011011: 1732mA																																																																				
011100: 777.0mA	011100: 1796mA																																																																				
011101: 804.75mA	011101: 1860mA																																																																				
011110: 832.5mA	011110: 1924mA																																																																				
011111: 860.25mA	011111: 1988mA																																																																				
100000 ... 111111: 888.0mA	100000 ... 111111: 2052mA																																																																				

(1) LEDs are off, V_{OUT} set according to OV[3:0].

(2) When FC13[4:0] and FC2[5:0] are both reset, the device operates in voltage regulation mode. The output voltage is set according to OV[3:0].

REGISTER2 DESCRIPTION

Memory location: 0x02

Description	MODE_CTRL[1:0]		ENVM	FC13[4:0]				
	D7	D6		D5	D4	D3	D2	D1
Bits								
Memory type	R/W	R/W	R/W	R/W	R/W	R/W	R/W	R/W
Default value	0	0	0	0	1	0	0	0

Bit	Description		
MODE_CTRL[1:0]	Mode Control bits. 00: Device in shutdown mode. 01: Device operates in DC light mode. 10: Device operates in flashlight mode. 11: Device operates as constant voltage source. To avoid device shutdown by DC light safety timeout, MODE_CTRL[1:0] bits need to be refreshed within less than 13.0s. Writing to REGISTER2[6:5] automatically updates REGISTER1[6:5].		
ENVM	Enable Voltage Mode bit. 0: Normal operation. 1: Forces the device into a constant voltage source. In read mode, the ENVM bit returns zero.		
FC13[4:0]	Flash Current Control bits (LED1/3). <table style="width: 100%; border: none;"> <tr> <td style="width: 50%; vertical-align: top;"> HC_SEL = 0 00000: 0mA. ⁽¹⁾ ⁽²⁾ 00001: 27.75mA 00010: 55.5mA 00011: 83.25mA 00100: 111.0mA 00101: 138.75mA 00110: 166.5mA 00111: 194.25mA 01000: 222.0mA 01001: 249.75mA 01010: 277.5mA 01011: 305.25mA 01100: 333.0mA 01101: 360.75mA 01110: 388.5mA 01111: 416.25mA 10000 ... 11111: 444.0mA </td> <td style="width: 50%; vertical-align: top;"> HC_SEL = 1 00000: 0mA. ⁽¹⁾ ⁽²⁾ 00001: 64.5mA 00010: 127.0mA 00011: 192.0mA 00100: 256.0mA 00101: 320.25mA 00110: 384.5mA 00111: 448.75mA 01000: 513.0mA 01001: 577.25mA 01010: 641.5mA 01011: 705.75mA 01100: 770.0mA 01101: 834.25mA 01110: 898.5mA 01111: 962.75mA 10000 ... 11111: 1027.0mA </td> </tr> </table>	HC_SEL = 0 00000: 0mA. ⁽¹⁾ ⁽²⁾ 00001: 27.75mA 00010: 55.5mA 00011: 83.25mA 00100: 111.0mA 00101: 138.75mA 00110: 166.5mA 00111: 194.25mA 01000: 222.0mA 01001: 249.75mA 01010: 277.5mA 01011: 305.25mA 01100: 333.0mA 01101: 360.75mA 01110: 388.5mA 01111: 416.25mA 10000 ... 11111: 444.0mA	HC_SEL = 1 00000: 0mA. ⁽¹⁾ ⁽²⁾ 00001: 64.5mA 00010: 127.0mA 00011: 192.0mA 00100: 256.0mA 00101: 320.25mA 00110: 384.5mA 00111: 448.75mA 01000: 513.0mA 01001: 577.25mA 01010: 641.5mA 01011: 705.75mA 01100: 770.0mA 01101: 834.25mA 01110: 898.5mA 01111: 962.75mA 10000 ... 11111: 1027.0mA
HC_SEL = 0 00000: 0mA. ⁽¹⁾ ⁽²⁾ 00001: 27.75mA 00010: 55.5mA 00011: 83.25mA 00100: 111.0mA 00101: 138.75mA 00110: 166.5mA 00111: 194.25mA 01000: 222.0mA 01001: 249.75mA 01010: 277.5mA 01011: 305.25mA 01100: 333.0mA 01101: 360.75mA 01110: 388.5mA 01111: 416.25mA 10000 ... 11111: 444.0mA	HC_SEL = 1 00000: 0mA. ⁽¹⁾ ⁽²⁾ 00001: 64.5mA 00010: 127.0mA 00011: 192.0mA 00100: 256.0mA 00101: 320.25mA 00110: 384.5mA 00111: 448.75mA 01000: 513.0mA 01001: 577.25mA 01010: 641.5mA 01011: 705.75mA 01100: 770.0mA 01101: 834.25mA 01110: 898.5mA 01111: 962.75mA 10000 ... 11111: 1027.0mA		

(1) LEDs are off, V_{OUT} set according to OV[3:0].

(2) When FC13[4:0] and FC2[5:0] are both reset, the device operates in voltage regulation mode. The output voltage is set according to OV[3:0].

REGISTER3 DESCRIPTION

Memory location: 0x03

Description	STIM[2:0]			HPLF	SELSTIM (W) TO (R)	STT	SFT	Tx-MASK
Bits	D7	D6	D5	D4	D3	D2	D1	D0
Memory type	R/W	R/W	R/W	R	R	R/W	R/W	R/W
Default value	1	1	0	0	0	0	0	1

Bit	Description																														
STIM[2:0]	<p>Safety Timer bits.</p> <table border="1"> <thead> <tr> <th>STIM[2:0]</th> <th>RANGE 0</th> <th>RANGE 1</th> <th>STIM[2:0]</th> <th>RANGE 0</th> <th>RANGE 1</th> </tr> </thead> <tbody> <tr> <td>000</td> <td>68.2ms</td> <td>5.3ms</td> <td>100</td> <td>204.5ms</td> <td>26.6ms</td> </tr> <tr> <td>001</td> <td>102.2ms</td> <td>10.7ms</td> <td>101</td> <td>340.8ms</td> <td>32.0ms</td> </tr> <tr> <td>010</td> <td>136.3ms</td> <td>16.0ms</td> <td>110</td> <td>579.3ms</td> <td>37.3ms</td> </tr> <tr> <td>011</td> <td>170.4ms</td> <td>21.3ms</td> <td>111</td> <td>852ms</td> <td>71.5ms</td> </tr> </tbody> </table>	STIM[2:0]	RANGE 0	RANGE 1	STIM[2:0]	RANGE 0	RANGE 1	000	68.2ms	5.3ms	100	204.5ms	26.6ms	001	102.2ms	10.7ms	101	340.8ms	32.0ms	010	136.3ms	16.0ms	110	579.3ms	37.3ms	011	170.4ms	21.3ms	111	852ms	71.5ms
STIM[2:0]	RANGE 0	RANGE 1	STIM[2:0]	RANGE 0	RANGE 1																										
000	68.2ms	5.3ms	100	204.5ms	26.6ms																										
001	102.2ms	10.7ms	101	340.8ms	32.0ms																										
010	136.3ms	16.0ms	110	579.3ms	37.3ms																										
011	170.4ms	21.3ms	111	852ms	71.5ms																										
HPFL	<p>High-Power LED Failure flag. 0: Proper LED operation. 1: LED failed (open or shorted). High-power LED failure flag is reset after readout</p>																														
SELSTIM	<p>Safety Timer Selection Range (Write Only). 0: Safety timer range 0. 1: Safety timer range 1.</p>																														
TO	<p>Time-Out Flag (Read Only). 0: No time-out event occurred. 1: Time-out event occurred. Time-out flag is reset at re-start of the safety timer.</p>																														
STT	<p>Safety Timer Trigger bit. 0: LED safety timer is level sensitive. 1: LED safety timer is rising edge sensitive. This bit is only valid for MODE_CTRL[1:0] = 10.</p>																														
SFT	<p>Start/Flash Timer bit. In write mode, this bit initiates a flash strobe sequence. Notice that this bit is only active when STRB0 input is high. 0: No change in the high-power LED current. 1: High-power LED current ramps to the flash current level. In read mode, this bit indicates the high-power LED status. 0: High-power LEDs are idle. 1: Ongoing high-power LED flash strobe.</p>																														
Tx-MASK	<p>Flash Blanking Control bit. In write mode, this bit enables/disables the flash blanking/LED current reduction function. 0: Flash blanking disabled. 1: LED current is reduced to DC light level when Tx-MASK input is high. In read mode, this flag indicates whether or not the flashlight masking input has been activated. Tx-MASK flag is reset after readout of the flag. 0: No flash blanking event occurred. 1: Tx-MASK input triggered.</p>																														

REGISTER4 DESCRIPTION

Memory location: 0x04

Description	PG	HOTDIE[1:0]			ILIM	INC[3:0]			
Bits	D7	D6	D5	D4	D3	D2	D1	D0	
Memory type	R/W	R	R	R/W	R/W	R/W	R/W	R/W	
Default value	0	0	0	0	0	0	0	0	

Bit	Description
PG	<p>Power Good bit.</p> <p>In write mode, this bit selects the functionality of the GPIO/PG output.</p> <p>0: PG signal is routed to the GPIO port.</p> <p>1: GPIO PORT VALUE bit is routed to the GPIO port.</p> <p>In read mode, this bit indicates the output voltage conditions.</p> <p>0: The converter is not operating within the voltage regulation limits.</p> <p>1: The output voltage is within its nominal value.</p>
HOTDIE[1:0]	<p>Instantaneous Die Temperature bits.</p> <p>00: $T_J < +55^\circ\text{C}$</p> <p>01: $+55^\circ\text{C} < T_J < +70^\circ\text{C}$</p> <p>10: $T_J > +70^\circ\text{C}$</p> <p>11: Thermal shutdown tripped. Indicator flag is reset after readout.</p>
ILIM	<p>Inductor Valley Current Limit bit.</p> <p>The ILIM bit can only be set before the device enters operation (i.e. initial shutdown state).</p>

VALLEY CURRENT LIMIT SETTING	ILIM BIT SETTING	HC_SEL INPUT LEVEL	Tx-MASK INPUT LEVEL
1150 mA	Low	Low	Low
1600 mA	High	Low	Low
30 mA	Low	High	Low
250 mA	High	High	Low
1150 mA	Low	Low	High
1600 mA	High	Low	High
n/a ⁽¹⁾	Low	High	High
n/a ⁽¹⁾	High	High	High

INDC[3:0]		Indicator Light Control bits.	
INDC[3:0]	PRIVACY INDICATOR INDLED CHANNEL	INDC[3:0]	PRIVACY INDICATOR LED1-3 CHANNELS ⁽²⁾
0000	Privacy indicator turned-off	1000	5% PWM dimming ratio
0001	INDLED current = 2.6mA ⁽³⁾	1001	11% PWM dimming ratio
0010	INDLED current = 5.2mA ⁽³⁾	1010	17% PWM dimming ratio
0011	INDLED current = 7.9mA ⁽³⁾	1011	23% PWM dimming ratio
0100	Privacy indicator turned-off	1100	30% PWM dimming ratio
0101	INDLED current = 5.2mA ⁽³⁾	1101	36% PWM dimming ratio
0110	INDLED current = 10.4mA ⁽³⁾	1110	48% PWM dimming ratio
0111	INDLED current = 15.8mA ⁽³⁾	1111	67% PWM dimming ratio

(1) The DC/DC power stage is disabled, zero current is being drained from the input source.

(2) This mode of operation can only be activated for MODE_CTRL[1:0] = 01 & ENVM = 1 & STRB1 = 0.

(3) For HC_SEL = L, the output node (VOUT) is internally pulled to ground.

REGISTER5 DESCRIPTION

Memory location: 0x05

Description	SELFAL	ENPSM	DIR (W) STSTRB1 (R)	GPIO	GPIOYPE	ENLED3	ENLED2	ENLED1
Bits	D7	D6	D5	D4	D3	D2	D1	D0
Memory type	R/W	R/W	R/W	R/W	R/W	R/W	R/W	R/W
Default value	0	1	1	0	1	0	1	0

Bit	Description
SELFAL	<p>High-Current LED Forward Voltage Self-Calibration Start bit. In write mode, this bit enables/disables the output voltage vs. LED forward voltage/current self-calibration procedure. 0: Self-calibration disabled. 1: Self-calibration enabled.</p> <p>In read mode, this bit returns the status of the self-calibration procedure. 0: Self-calibration ongoing 1: Self-calibration done Notice that this bit is only being reset at the (re-)start of a calibration cycle.</p>
ENPSM	<p>Enable / Disable Power-Save Mode bit. 0: Power-save mode disabled. 1: Power-save mode enabled.</p>
STSTRB1	<p>STRB1 Input Status bit (Read Only). This bit indicates the logic state on the STRB1 state.</p>
DIR	<p>GPIO Direction bit. 0: GPIO configured as input. 1: GPIO configured as output.</p>
GPIO	<p>GPIO Port Value. This bit contains the GPIO port value.</p>
GPIOYPE	<p>GPIO Port Type. 0: GPIO is configured as push-pull output. 1: GPIO is configured as open-drain output.</p>
ENLED3	<p>Enable / Disable High-Current LED3 bit. 0: LED3 input is disabled. 1: LED3 input is enabled.</p>
ENLED2	<p>Enable / Disable High-Current LED2 bit. 0: LED2 input is disabled. 1: LED2 input is enabled.</p>
ENLED1	<p>Enable / Disable High-Current LED1 bit. 0: LED1 input is disabled. 1: LED1 input is enabled.</p>

REGISTER6 DESCRIPTION

Memory location: 0x06

Description	ENTS	LEDHOT	LEDWARN	LEDHDR	OV[3:0]			
Bits	D7	D6	D5	D4	D3	D2	D1	D0
Memory type	R/W	R/W	R	R	R/W	R/W	R/W	R/W
Default value	0	0	0	0	1	0	0	1

Bit	Description
ENTS	Enable / Disable LED Temperature Monitoring. 0: LED temperature monitoring disabled. 1: LED temperature monitoring enabled
LEDHOT	LED Excessive Temperature Flag. This bit can be reset by writing a logic level zero. 0: TS input voltage > 0.345V. 1: TS input voltage < 0.345V.
LEDWARN	LED Temperature Warning Flag (Read Only). This flag is reset after readout. 0: TS input voltage > 1.05V. 1: TS input voltage < 1.05V.
LEDHDR	LED High-Current Regulator Headroom Voltage Monitoring bit. This bit returns the headroom voltage status of the LED high-current regulators. This value is being updated at the end of a flash strobe, prior to the LED current ramp-down phase. 0: Low headroom voltage. 1: Sufficient headroom voltage.
OV[3:0]	Output Voltage Selection bits. In read mode, these bits return the result of the high-current LED forward voltage self-calibration procedure. In write mode, these bits are used to set the target output voltage (refer to voltage regulation mode). In applications requiring dynamic voltage control, care should be take to set the new target code after voltage mode operation has been enabled (MODE_CTRL[1:0] = 11 and/or ENVM bit = 1).

OV[3:0]	Target Output Voltage
0000	3.825V
0001	3.950V
0010	4.075V
0011	4.200V
0100	4.325V
0101	4.450V
0110	4.575V
0111	4.700V
1000	4.825V
1001	4.950V
1010	5.075V
1011	5.200V
1100	5.325V
1101	5.450V
1110	5.575V
1111	5.700V

REGISTER7 DESCRIPTION

Memory location: 0x07

Description	NOT USED					REVID[2:0]		
Bits	D7	D6	D5	D4	D3	D2	D1	D0
Memory type	R/W	R/W	R/W	R/W	R/W	R	R	R
Default value	0	0	0	0	0	1	1	0

Bit	Description
REVID[2:0]	Silicon Revision ID.

APPLICATION INFORMATION

INDUCTOR SELECTION

A boost converter requires two main passive components for storing energy during the conversion. A boost inductor and a storage capacitor at the output are required. The TPS6132x device integrates a current limit protection circuitry. The valley current of the PMOS rectifier is sensed to limit the maximum current flowing through the synchronous rectifier and the inductor. The valley peak current limit (250mA/1150mA/1600mA) is user selectable via the I²C interface.

In order to optimize solution size the TPS6132x device has been designed to operate with inductance values between a minimum of 1.3 μH and maximum of 2.9 μH. In typical high current white LED applications a 2.2μH inductance is recommended.

The highest peak current through the inductor and the power switch depends on the output load, the input and output voltages. Estimation of the maximum average inductor current and the maximum inductor peak current can be done using [Equation 2](#) and [Equation 3](#):

$$I_L \approx I_{OUT} \times \frac{V_{OUT}}{\eta \times V_{IN}} \quad (2)$$

$$I_{L(PEAK)} = \frac{V_{IN} \times D}{2 \times f \times L} + \frac{I_{OUT}}{(1-D) \times \eta} \quad \text{with } D = \frac{V_{OUT} - V_{IN}}{V_{OUT}} \quad (3)$$

With

f = switching frequency (2MHz)

L = inductance value (2.2μH)

η = estimated efficiency (85%)

The losses in the inductor caused by magnetic hysteresis losses and copper losses are a major parameter for total circuit efficiency.

Table 4. List of Inductors

MANUFACTURER	SERIES	DIMENSIONS	ILIM SETTINGS
FDK	MIPST2520	2.5mm x 2.0mm x 0.8mm max. height	250mA (typ.)
	MIP2520	2.5mm x 2.0mm x 1.0mm max. height	
	MIPSA2520	2.5mm x 2.0mm x 1.2mm max. height	
MURATA	LQM2HP-G0	2.5mm x 2.0mm x 1.0mm max. height	1150mA (typ.)
	LQM2HP-GC	2.5mm x 2.0mm x 1.0mm max. height	
TDK	VL3014AT	2.6mm x 2.8mm x 1.4mm max. height	1600mA (typ.)
COILCRAFT	LPS3015	3.0mm x 3.0mm x 1.5mm max. height	
MURATA	LQH2HPN	2.5mm x 2.0mm x 1.2mm max. height	
TOKO	FDSE0312	3.0mm x 3.0mm x 1.2mm max. height	1600mA (typ.)
MURATA	LQM32PN	3.2mm x 2.5mm x 1.2mm max. height	

INPUT CAPACITOR

For good input voltage filtering low ESR ceramic capacitors are recommended. A 10-μF input capacitor is recommended to improve transient behavior of the regulator and EMI behavior of the total power supply circuit. The input capacitor should be placed as close as possible to the input pin of the converter.

OUTPUT CAPACITOR

The major parameter necessary to define the output capacitor is the maximum allowed output voltage ripple of the converter. This ripple is determined by two parameters of the capacitor, the capacitance and the ESR. It is possible to calculate the minimum capacitance needed for the defined ripple, supposing that the ESR is zero, by using [Equation 4](#):

$$C_{\min} \approx \frac{I_{\text{OUT}} \times (V_{\text{OUT}} - V_{\text{IN}})}{f \times \Delta V \times V_{\text{OUT}}} \quad (4)$$

Parameter f is the switching frequency and ΔV is the maximum allowed ripple.

With a chosen ripple voltage of 10mV, a minimum capacitance of 10 μ F is needed. The total ripple is larger due to the ESR of the output capacitor. This additional component of the ripple can be calculated using [Equation 5](#):

$$\Delta V_{\text{ESR}} = I_{\text{OUT}} \times R_{\text{ESR}} \quad (5)$$

The total ripple is the sum of the ripple caused by the capacitance and the ripple caused by the ESR of the capacitor. Additional ripple is caused by load transients. This means that the output capacitor has to completely supply the load during the charging phase of the inductor. A reasonable value of the output capacitance depends on the speed of the load transients and the load current during the load change.

For the standard current white LED application ($\text{HC_SEL} = 0$, TPS6132x), a minimum of 3 μ F effective output capacitance is usually required when operating with 2.2 μ H (typ) inductors. For solution size reasons, this is usually one or more X5R/X7R ceramic capacitors.

Depending on the material, size and therefore margin to the rated voltage of the used output capacitor, degradation on the effective capacitance can be observed. This loss of capacitance is related to the DC bias voltage applied. It is therefore always recommended to check that the selected capacitors are showing enough effective capacitance under real operating conditions.

To support high-current camera flash application ($\text{HC_SEL} = 1$), the converter is designed to work with a low voltage super-capacitor on the output to take advantage of the benefits they offer. A low-voltage super-capacitor in the 0.1F to 1.5F range, and with ESR larger than 40m Ω , is suitable in the TPS6132x application circuit. For this device the output capacitor should be connected between the VOUT pin and a good ground connection.

NTC SELECTION

The TPS6132x requires a negative thermistor (NTC) for sensing the LED temperature. Once the temperature monitoring feature is activated, a regulated bias current (c.a. 24µA) will be driven out of the TS port and produce a voltage across the thermistor.

If the temperature of the NTC-thermistor rises due to the heat dissipated by the LED, the voltage on the TS input pin decreases. When this voltage goes below the “warning threshold”, the LEDWARN bit in REGISTER6 is set. This flag is cleared by reading the register.

If the voltage on the TS input decreases further and falls below “hot threshold”, the LEDHOT bit in REGISTER6 is set and the device goes automatically in shutdown mode to avoid damaging the LED. This status is latched until the LEDHOT flag gets cleared by software.

The selection of the NTC-thermistor value strongly depends on the power dissipated by the LED and all components surrounding the temperature sensor and on the cooling capabilities of each specific application. With a 220kΩ (at 25°C) thermistor, the valid temperature window is set between 60°C to 90°C. The temperature window can be enlarged by adding external resistors to the TS pin application circuit. In order to ensure proper triggering of the LEDWARN and LEDHOT flags in noisy environments, the TS signal may require additional filtering capacitance.

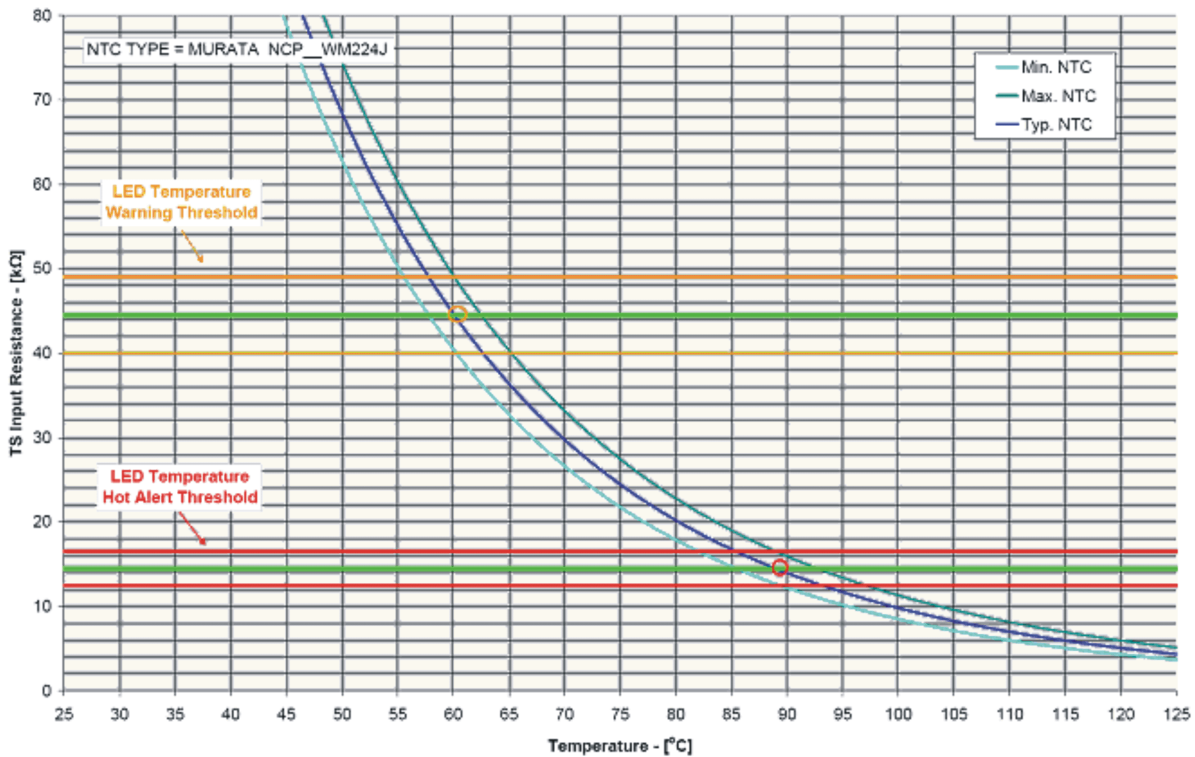

Figure 74. Temperature Monitoring Characteristic

Table 5. List of Negative Thermistor (NTC)

MANUFACTURER	PART NUMBER	VALUE
MURATA	NCP18WM224J03RB	220kΩ

CHECKING LOOP STABILITY

The first step of circuit and stability evaluation is to look from a steady-state perspective at the following signals:

- Switching node, SW
- Inductor current, I_L
- Output ripple voltage, $V_{OUT(AC)}$

These are the basic signals that need to be measured when evaluating a switching converter. When the switching waveform shows large duty cycle jitter or the output voltage or inductor current shows oscillations the regulation loop may be unstable. This is often a result of improper board layout and/or L-C combination.

As a next step in the evaluation of the regulation loop the load transient response needs to be tested. VOUT can be monitored for settling time, overshoot or ringing that helps judge the converter's stability. Without any ringing, the loop has usually more than 45° of phase margin.

Because the damping factor of the circuitry is directly related to several resistive parameters (e.g., MOSFET $r_{DS(on)}$) that are temperature dependant, the loop stability analysis has to be done over the input voltage range, output current range, and temperature range.

LAYOUT CONSIDERATIONS

As for all switching power supplies, the layout is an important step in the design, especially at high peak currents and high switching frequencies. If the layout is not carefully done, the regulator could show stability problems as well as EMI problems. Therefore, use wide and short traces for the main current path and for the power ground tracks.

The input capacitor, output capacitor, and the inductor should be placed as close as possible to the IC. Use a common ground node for power ground and a different one for control ground to minimize the effects of ground noise. Connect these ground nodes at any place close to one of the ground pins of the IC.

To lay out the control ground, it is recommended to use short traces as well, separated from the power ground traces. This avoids ground shift problems, which can occur due to superimposition of power ground current and control ground current.

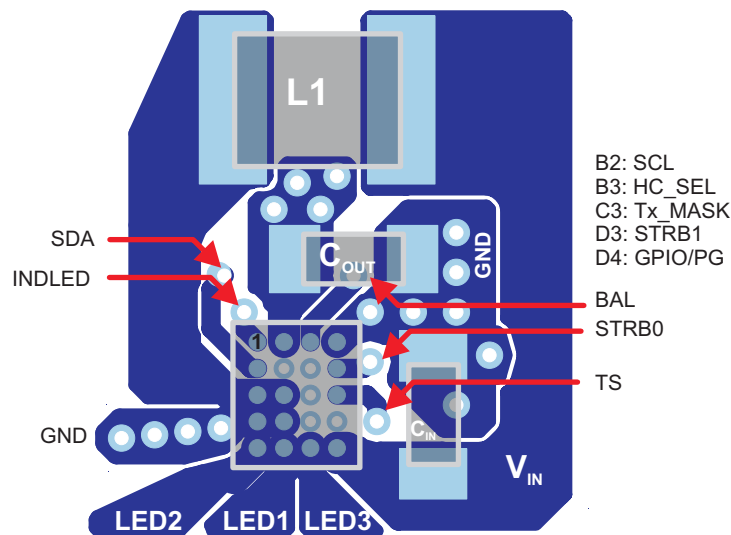

Figure 75. Suggested Layout (Top)

THERMAL INFORMATION

Implementation of integrated circuits in low-profile and fine-pitch surface-mount packages typically requires special attention to power dissipation. Many system-dependant issues such as thermal coupling, airflow, added heat sinks and convection surfaces, and the presence of other heat-generating components affect the power-dissipation limits of a given component.

Three basic approaches for enhancing thermal performance are listed below:

- Improving the power dissipation capability of the PCB design
- Improving the thermal coupling of the component to the PCB
- Introducing airflow in the system

Junction-to-ambient thermal resistance is highly application and board-layout dependent. In applications where high maximum power dissipation exists, special care must be paid to thermal dissipation issues in board design. The maximum junction temperature (T_J) of the TPS6132x is 150°C.

The maximum power dissipation is especially critical when the device operates in the linear down mode at high LED current. For single pulse power thermal analysis (e.g., flashlight strobe), the allowable power dissipation for the device is given by [Figure 76](#). These values are derived using the reference design.

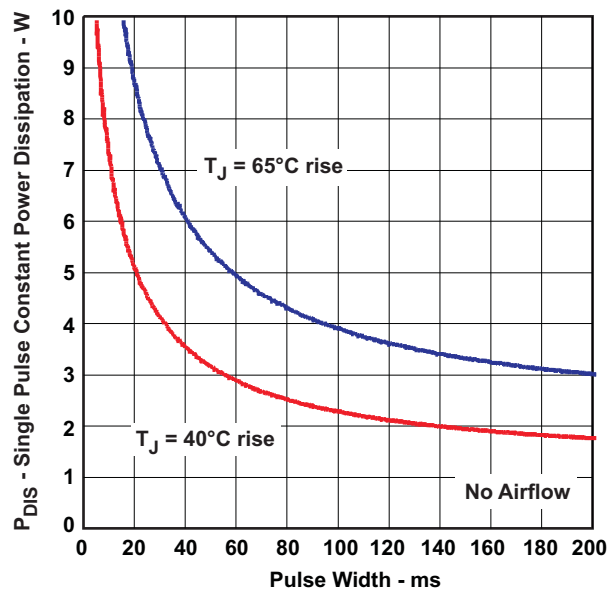

Figure 76. Single Pulse Power Capability

TYPICAL APPLICATIONS

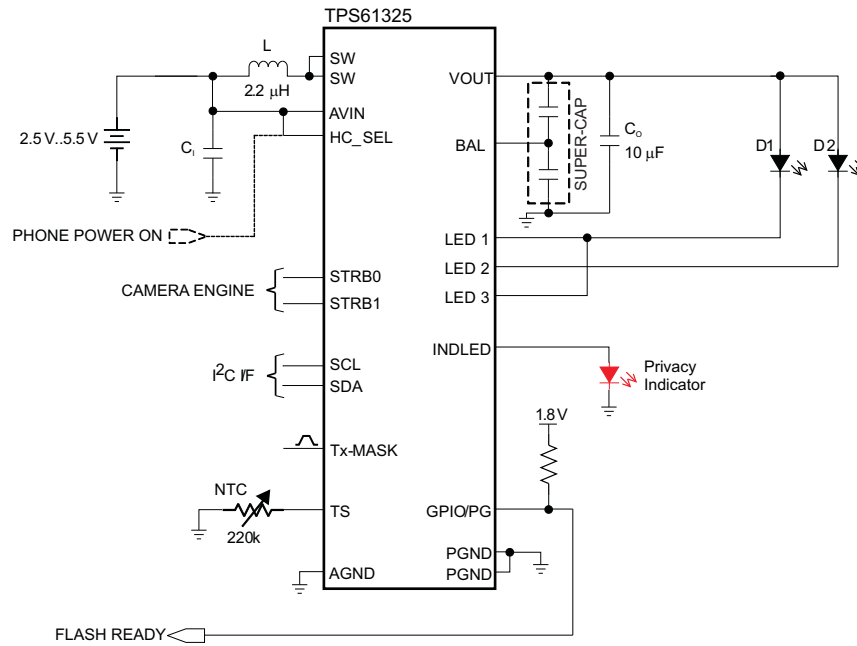

Figure 77. 4100mA Two White High-Power LED Flashlight Featuring Storage Capacitor

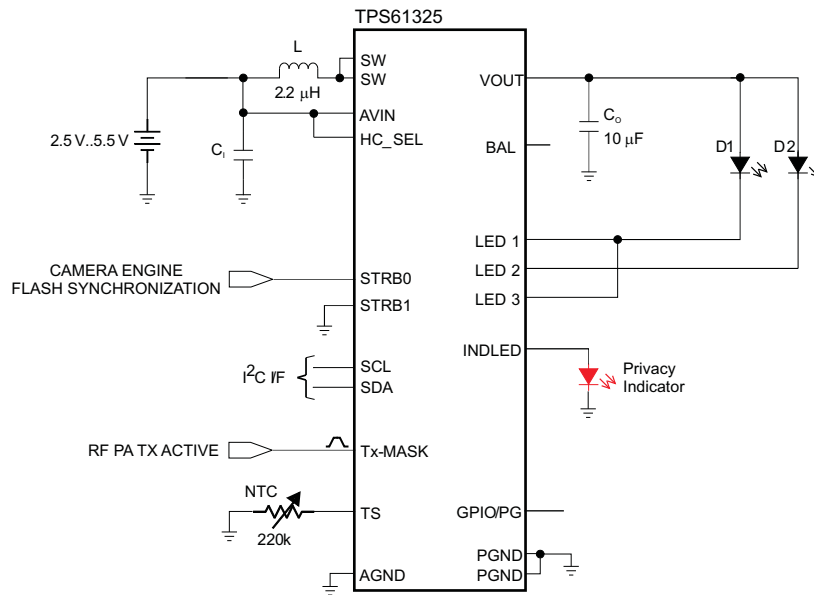

Figure 78. 2x 600mA High Power White LED Solution Featuring Privacy Indicator

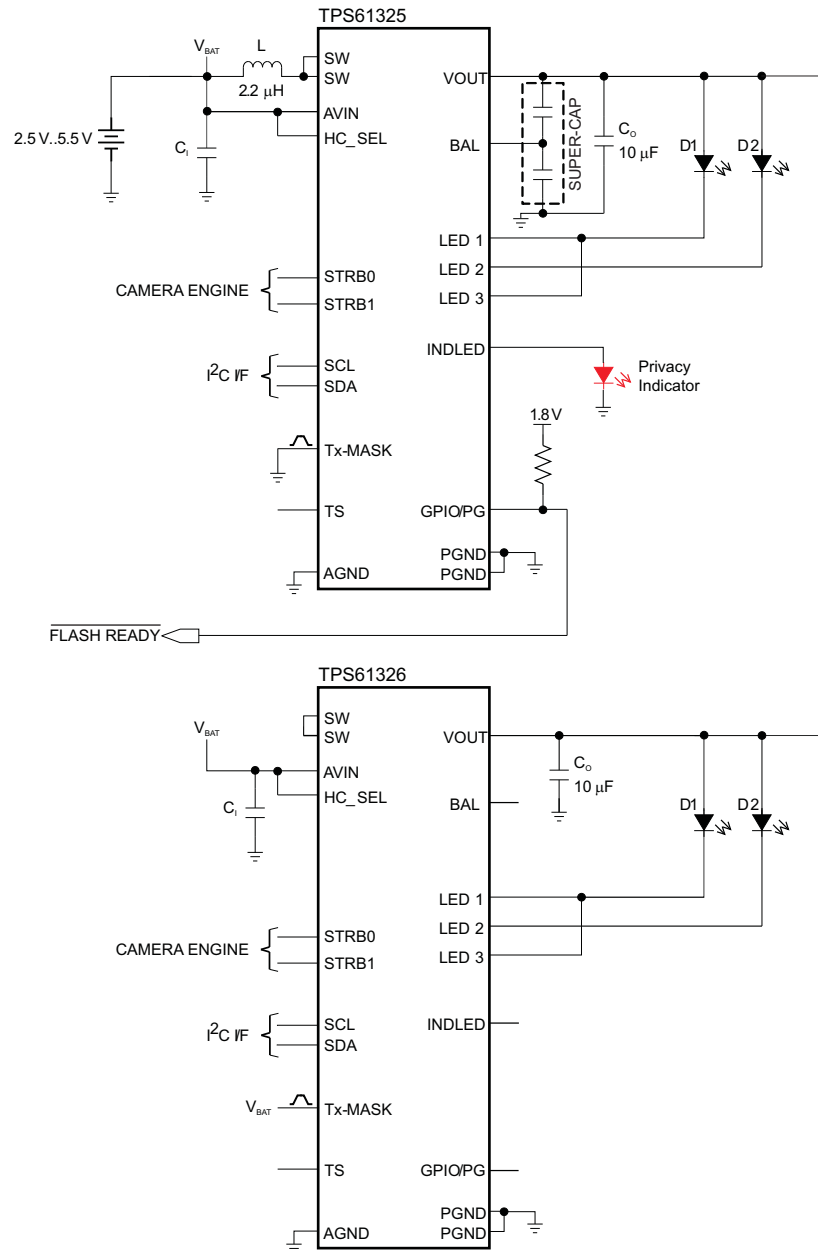
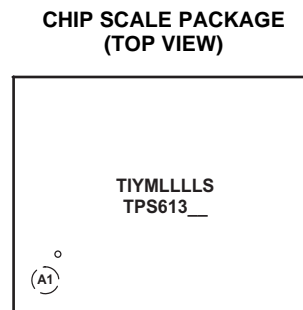
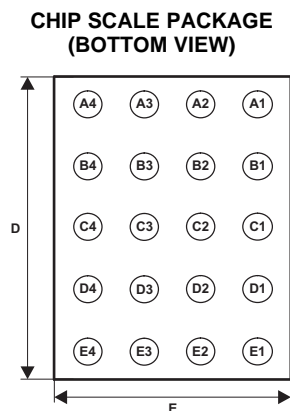

Figure 79. 8200mA Four White High-Power LED Flashlight Featuring Storage Capacitor

PACKAGE SUMMARY



Code:

- YM — Year Month date code
- LLLL — Lot trace code
- S — Assembly site code

CHIP SCALE PACKAGE DIMENSIONS

The TPS6132x device is available in a 20-bump chip scale package (YFF, NanoFree™). The package dimensions are given as:

- D = 2170 ±30 μm
- E = 1928 ±30 μm

Changes from Original (February 2010) to Revision A**Page**

• Added TPS61326 device as Product Preview	2
• Changed I_{STBY} specification, max value from 5 μ A to 12 μ A	3
• Changed V_{DO} specification, max. value from 200mV to 250mV for Test Condition $I_{OUT} = -15.8$ mA, $T_J = +25^\circ$ C, device not switching.	4

PACKAGING INFORMATION

Orderable Device	Status (1)	Package Type	Package Drawing	Pins	Package Qty	Eco Plan (2)	Lead/Ball Finish	MSL Peak Temp (3)	Op Temp (°C)	Top-Side Markings (4)	Samples
TPS61325YFFR	ACTIVE	DSBGA	YFF	20	3000	Green (RoHS & no Sb/Br)	SNAGCU	Level-1-260C-UNLIM	-40 to 85	TPS61325	Samples
TPS61325YFFT	ACTIVE	DSBGA	YFF	20	250	Green (RoHS & no Sb/Br)	SNAGCU	Level-1-260C-UNLIM	-40 to 85	TPS61325	Samples

(1) The marketing status values are defined as follows:

ACTIVE: Product device recommended for new designs.

LIFEBUY: TI has announced that the device will be discontinued, and a lifetime-buy period is in effect.

NRND: Not recommended for new designs. Device is in production to support existing customers, but TI does not recommend using this part in a new design.

PREVIEW: Device has been announced but is not in production. Samples may or may not be available.

OBSOLETE: TI has discontinued the production of the device.

(2) Eco Plan - The planned eco-friendly classification: Pb-Free (RoHS), Pb-Free (RoHS Exempt), or Green (RoHS & no Sb/Br) - please check <http://www.ti.com/productcontent> for the latest availability information and additional product content details.

TBD: The Pb-Free/Green conversion plan has not been defined.

Pb-Free (RoHS): TI's terms "Lead-Free" or "Pb-Free" mean semiconductor products that are compatible with the current RoHS requirements for all 6 substances, including the requirement that lead not exceed 0.1% by weight in homogeneous materials. Where designed to be soldered at high temperatures, TI Pb-Free products are suitable for use in specified lead-free processes.

Pb-Free (RoHS Exempt): This component has a RoHS exemption for either 1) lead-based flip-chip solder bumps used between the die and package, or 2) lead-based die adhesive used between the die and leadframe. The component is otherwise considered Pb-Free (RoHS compatible) as defined above.

Green (RoHS & no Sb/Br): TI defines "Green" to mean Pb-Free (RoHS compatible), and free of Bromine (Br) and Antimony (Sb) based flame retardants (Br or Sb do not exceed 0.1% by weight in homogeneous material)

(3) MSL, Peak Temp. -- The Moisture Sensitivity Level rating according to the JEDEC industry standard classifications, and peak solder temperature.

(4) Multiple Top-Side Markings will be inside parentheses. Only one Top-Side Marking contained in parentheses and separated by a "~" will appear on a device. If a line is indented then it is a continuation of the previous line and the two combined represent the entire Top-Side Marking for that device.

Important Information and Disclaimer: The information provided on this page represents TI's knowledge and belief as of the date that it is provided. TI bases its knowledge and belief on information provided by third parties, and makes no representation or warranty as to the accuracy of such information. Efforts are underway to better integrate information from third parties. TI has taken and continues to take reasonable steps to provide representative and accurate information but may not have conducted destructive testing or chemical analysis on incoming materials and chemicals. TI and TI suppliers consider certain information to be proprietary, and thus CAS numbers and other limited information may not be available for release.

In no event shall TI's liability arising out of such information exceed the total purchase price of the TI part(s) at issue in this document sold by TI to Customer on an annual basis.

TAPE AND REEL INFORMATION

QUADRANT ASSIGNMENTS FOR PIN 1 ORIENTATION IN TAPE

*All dimensions are nominal

Device	Package Type	Package Drawing	Pins	SPQ	Reel Diameter (mm)	Reel Width W1 (mm)	A0 (mm)	B0 (mm)	K0 (mm)	P1 (mm)	W (mm)	Pin1 Quadrant
TPS61325YFFR	DSBGA	YFF	20	3000	180.0	8.4	2.2	2.35	0.8	4.0	8.0	Q1
TPS61325YFFT	DSBGA	YFF	20	250	180.0	8.4	2.2	2.35	0.8	4.0	8.0	Q1

TAPE AND REEL BOX DIMENSIONS

*All dimensions are nominal

Device	Package Type	Package Drawing	Pins	SPQ	Length (mm)	Width (mm)	Height (mm)
TPS61325YFFR	DSBGA	YFF	20	3000	210.0	185.0	35.0
TPS61325YFFT	DSBGA	YFF	20	250	210.0	185.0	35.0

YFF (R-XBGA-N20)

DIE-SIZE BALL GRID ARRAY

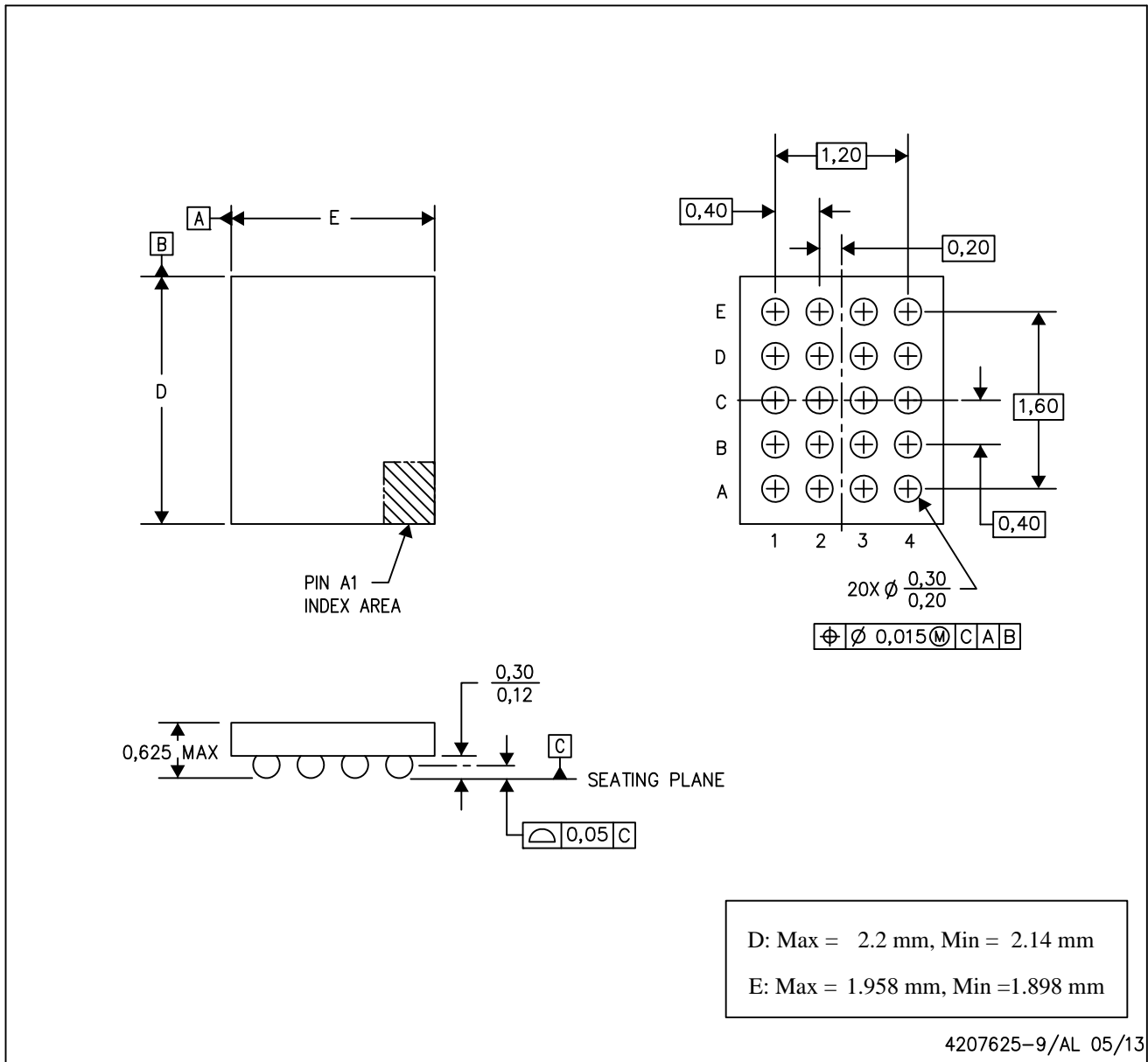

- NOTES: A. All linear dimensions are in millimeters. Dimensioning and tolerancing per ASME Y14.5M-1994.
B. This drawing is subject to change without notice.
C. NanoFree™ package configuration.

IMPORTANT NOTICE

Texas Instruments Incorporated and its subsidiaries (TI) reserve the right to make corrections, enhancements, improvements and other changes to its semiconductor products and services per JESD46, latest issue, and to discontinue any product or service per JESD48, latest issue. Buyers should obtain the latest relevant information before placing orders and should verify that such information is current and complete. All semiconductor products (also referred to herein as "components") are sold subject to TI's terms and conditions of sale supplied at the time of order acknowledgment.

TI warrants performance of its components to the specifications applicable at the time of sale, in accordance with the warranty in TI's terms and conditions of sale of semiconductor products. Testing and other quality control techniques are used to the extent TI deems necessary to support this warranty. Except where mandated by applicable law, testing of all parameters of each component is not necessarily performed.

TI assumes no liability for applications assistance or the design of Buyers' products. Buyers are responsible for their products and applications using TI components. To minimize the risks associated with Buyers' products and applications, Buyers should provide adequate design and operating safeguards.

TI does not warrant or represent that any license, either express or implied, is granted under any patent right, copyright, mask work right, or other intellectual property right relating to any combination, machine, or process in which TI components or services are used. Information published by TI regarding third-party products or services does not constitute a license to use such products or services or a warranty or endorsement thereof. Use of such information may require a license from a third party under the patents or other intellectual property of the third party, or a license from TI under the patents or other intellectual property of TI.

Reproduction of significant portions of TI information in TI data books or data sheets is permissible only if reproduction is without alteration and is accompanied by all associated warranties, conditions, limitations, and notices. TI is not responsible or liable for such altered documentation. Information of third parties may be subject to additional restrictions.

Resale of TI components or services with statements different from or beyond the parameters stated by TI for that component or service voids all express and any implied warranties for the associated TI component or service and is an unfair and deceptive business practice. TI is not responsible or liable for any such statements.

Buyer acknowledges and agrees that it is solely responsible for compliance with all legal, regulatory and safety-related requirements concerning its products, and any use of TI components in its applications, notwithstanding any applications-related information or support that may be provided by TI. Buyer represents and agrees that it has all the necessary expertise to create and implement safeguards which anticipate dangerous consequences of failures, monitor failures and their consequences, lessen the likelihood of failures that might cause harm and take appropriate remedial actions. Buyer will fully indemnify TI and its representatives against any damages arising out of the use of any TI components in safety-critical applications.

In some cases, TI components may be promoted specifically to facilitate safety-related applications. With such components, TI's goal is to help enable customers to design and create their own end-product solutions that meet applicable functional safety standards and requirements. Nonetheless, such components are subject to these terms.

No TI components are authorized for use in FDA Class III (or similar life-critical medical equipment) unless authorized officers of the parties have executed a special agreement specifically governing such use.

Only those TI components which TI has specifically designated as military grade or "enhanced plastic" are designed and intended for use in military/aerospace applications or environments. Buyer acknowledges and agrees that any military or aerospace use of TI components which have **not** been so designated is solely at the Buyer's risk, and that Buyer is solely responsible for compliance with all legal and regulatory requirements in connection with such use.

TI has specifically designated certain components as meeting ISO/TS16949 requirements, mainly for automotive use. In any case of use of non-designated products, TI will not be responsible for any failure to meet ISO/TS16949.

Products

Audio	www.ti.com/audio
Amplifiers	amplifier.ti.com
Data Converters	dataconverter.ti.com
DLP® Products	www.dlp.com
DSP	dsp.ti.com
Clocks and Timers	www.ti.com/clocks
Interface	interface.ti.com
Logic	logic.ti.com
Power Mgmt	power.ti.com
Microcontrollers	microcontroller.ti.com
RFID	www.ti-rfid.com
OMAP Applications Processors	www.ti.com/omap
Wireless Connectivity	www.ti.com/wirelessconnectivity

Applications

Automotive and Transportation	www.ti.com/automotive
Communications and Telecom	www.ti.com/communications
Computers and Peripherals	www.ti.com/computers
Consumer Electronics	www.ti.com/consumer-apps
Energy and Lighting	www.ti.com/energy
Industrial	www.ti.com/industrial
Medical	www.ti.com/medical
Security	www.ti.com/security
Space, Avionics and Defense	www.ti.com/space-avionics-defense
Video and Imaging	www.ti.com/video

TI E2E Community

e2e.ti.com