

# 13 Channel ESD Protection Solution with Current-Limit Load Switch for HDMI Port

Check for Samples: [TPD13S523](#)

## FEATURES

- Single Chip ESD Solution for HDMI 1.4 and HDMI 1.3 Interface
- On-chip 5V Load Switch with Current Limit and Reverse Current Protection
- Supports UTILITY Line Protection for HDMI 1.4 Audio Return Line
- <0.05-pF Differential Capacitance Between the TMDS Signal Pair
- Industry Standard 16-TSSOP and Space Saving 16-RSV Package
- Supports Data Rates in Excess of 3.3Gbps
- $R_{DYN}$  0.5 $\Omega$
- IEC 61000-4-2 (Level 4) ESD Compliance
- Commercial Temperature Range: –40°C to 85°C

## APPLICATIONS

- Set-top Box
- Smart Phone
- Digital Camcorder
- Portable Game Console

## DESCRIPTION

The TPD13S523 is a single-chip integrated ESD protection solution for HDMI 1.4 or HDMI 1.3 interface. This device offers 13 channels of ESD clamp circuits with flow-through pin mapping that matches HDMI connector high-speed lines. While providing ESD protection, the TPD13S523 adds little to no additional distortion to the high-speed differential signals. The monolithic integrated circuit technology ensures that there is excellent matching between the two-signal pair of the differential line (<0.05pF differential matching between TMDS lines). This is an advantage over discrete ESD clamp solutions where variations between two different ESD clamps may significantly degrade the differential signal quality.

The TPD13S523 incorporates an on-chip current limited load switch that is compliant with HDMI 5V out electrical specifications. The short circuit protection at 5V\_OUT ensures that the device is not damaged in case there is accidental short to GND. The load switch also incorporates reverse current blocking feature which ensures that the HDMI driver side is not erroneously turned on when two HDMI drivers are connected together.

Connecting a 0.1 $\mu$ F to 1 $\mu$ F capacitor at 5V\_OUT, TPD13S523 protects the system against  $\pm$ 12kV contact and  $\pm$ 14kV air-gap ESD discharge.

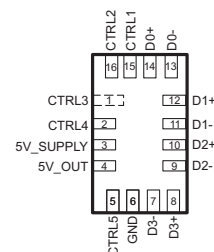
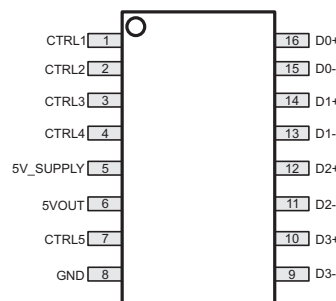
**16-RSV: 2.6mm x 1.8mm  
(TOP VIEW)**

**16-TSSOP: 6.4mm x 5.0mm  
(TOP VIEW)**

All the CTRLx pins have the same ESD circuit and are interchangeable.

## ORDERING INFORMATION

T <sub>A</sub>	PACKAGE <sup>(1)(2)</sup>		ORDERABLE PART NUMBER	TOP-SIDE MARKING
–40°C to 85°C	3000	Tape and reel	TPD13S523PWR	RA523
	3000	Tape and reel	TPD13S523RSVR	ZTT

(1) Package drawings, thermal data, and symbolization are available at [www.ti.com/packageing](http://www.ti.com/packageing).

(2) For the most current package and ordering information, see the Package Option Addendum at the end of this document, or see the TI Web site at [www.ti.com](http://www.ti.com).



Please be aware that an important notice concerning availability, standard warranty, and use in critical applications of Texas Instruments semiconductor products and disclaimers thereto appears at the end of this data sheet.



These devices have limited built-in ESD protection. The leads should be shorted together or the device placed in conductive foam during storage or handling to prevent electrostatic damage to the MOS gates.

**CIRCUIT BLOCK DIAGRAMS**

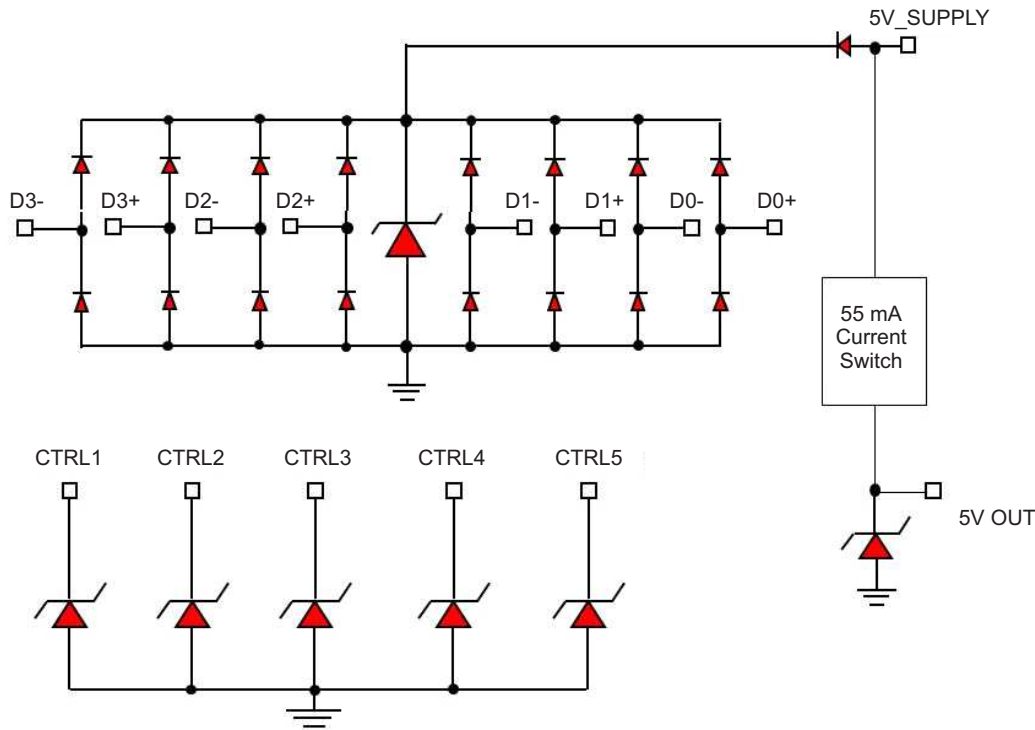

Figure 1. Electrical Equivalent Circuit Diagrams

**ESD TERMINAL DESCRIPTIONS**

SIGNAL	TSSOP PIN NO.	RSV PIN NO.	TYPE	DESCRIPTION
Dx+, Dx-	9, 10, 11, 12, 13, 14, 15, 16	7, 8, 9, 10, 11, 12, 13, 14	connector pins <sup>(1)</sup>	High-speed ESD Clamp: provides ESD protection for TMDS lines.
CTRLx	1, 2, 3, 4, 7	1, 2, 5, 15, 16	connector pins <sup>(1)</sup>	ESD Clamp for Control Lines: provides ESD protection to HDMI control lines: CEC, SCL, SDA, HPD, and UTILITY. All the control pins have the same ESD circuit and are interchangeable.

(1) Connector pins are Dx+, Dx-, CTRLx, and 5V\_OUT

**SUPPLY TERMINAL DESCRIPTIONS**

SIGNAL	TSSOP PIN NO.	RSV PIN NO.	TYPE	DESCRIPTION
5V_SUPPLY	5	3	Supply pin	<b>Supply Pin for HDMI 5V_OUT</b> 5.0 Volts, connects to internal VCC plane on the PCB board; connect a 0.1 to 1µF capacitor shunt to ground.
5V_OUT	6	4	HDMI 5VOUT pin	<b>Current Limited HDMI 5V_OUT:</b> connect to HDMI 5V_OUT; offers IEC61000-4-2 ESD protection; connect a 0.1 to 1µF capacitor shunt to ground.

## LAYOUT SCHEME USING TPD13S523

The TPD13S523 device offers little or no signal distortion during normal operation due to low IO capacitance and ultra-low leakage current specifications. In the event of an ESD stress, this device ensures that the core circuitry is protected and the system is functioning properly. For proper operation, the following layout/ design guidelines should be followed:

1. Place the TPD13S523 as close to the connector as possible. This allows the TPD13S523 to take away the energy associated with ESD strike before it reaches the internal circuitry of the system board.
2. Place two 0.1- $\mu$ F capacitors very close to the 5V\_SUPPLY and 5VOUT pins. These capacitors will help limit the noise at the 5VOUT power line, and also help with system level ESD protection.
3. Ensure that there is enough metallization for the GND pad. During normal operation, the TPD13S523 ESD pins consume ultra low leakage current. During the ESD event, GND pin will see multiple amps current. Sufficient current paths enables safe discharge of all the energy associated with the ESD strike.
4. Leave the unused IO pins floating. If there is no UTILITY pin protection required, it is recommended to leave CTRL5 open (Figure 2). Connect the CEC, SCL, SDA, and HPD lines to CTRL1-CTRL4 pins.
5. The critical routing paths for HDMI interface are the high-speed TMDS lines. With the PW package, all the TMDS lines (pin Dxx) can be routed in a single signal plane and still maintain the differential coupling & trace symmetry. This helps reduce the overall board manufacturing cost. The slow speed control lines can be routed in another signal layer through VIAs.

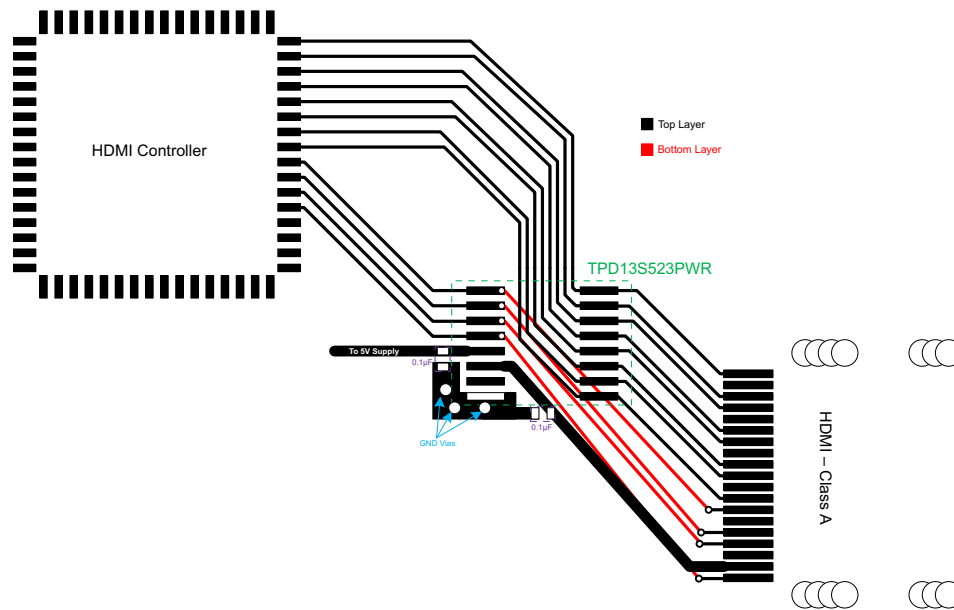

Figure 2. TPD13S523PWR Layout Example 12-Line HDMI Protection (Leave CTRL5 Open)

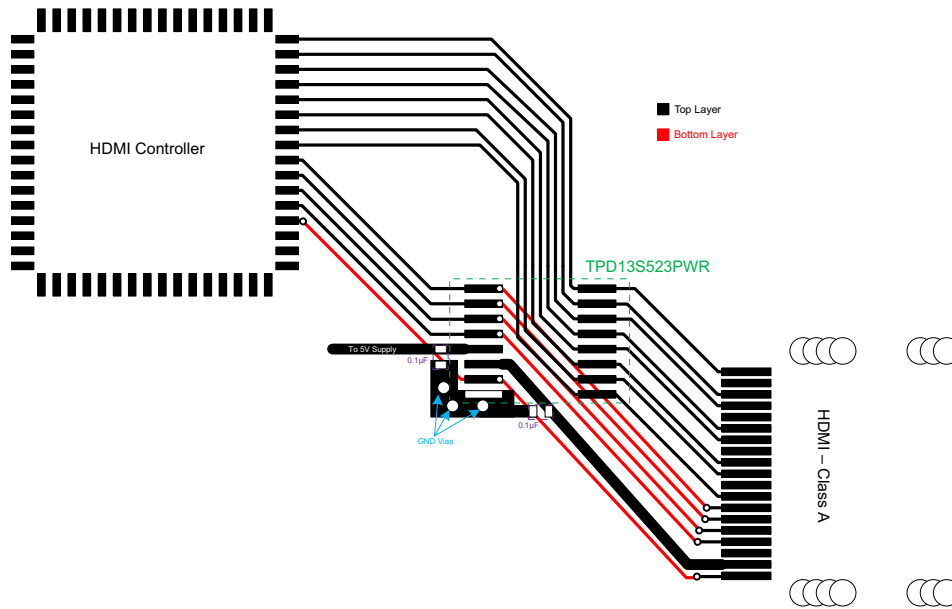

Figure 3. TPD13S523PWR Layout Example 13-Line HDMI Protection (Additional UTILITY Line Protection)

**ABSOLUTE MAXIMUM RATINGS**

T<sub>A</sub> = -40°C to 85°C

DESCRIPTION		MIN	MAX	UNIT
V <sub>CC</sub> Voltage Tolerance	5V_SUPPLY	-0.3	6	V
IO Voltage Tolerance	Connector Pins <sup>(1)</sup>	-0.3	6	V
Storage Temperature		-65	125	°C
IEC 61000-4-2 Contact Discharge	Connector Pins <sup>(1)</sup>		±12	kV
IEC 61000-4-2 Air-gap Discharge	Connector Pins <sup>(1)</sup>		±14	kV
IEC 61000-4-5 Peak current (8/20 μs)	Connector Pins <sup>(1)</sup>		3	A
IEC 61000-4-5 Peak Power (8/20 μs)	Connector Pins <sup>(1)</sup>		30	W

(1) Connector pins are Dx+, Dx-, CTRLx, and 5V\_OUT

**THERMAL INFORMATION**

THERMAL METRIC <sup>(1)</sup>		TPD13S523PW	UNITS
		TSSOP	
		16 PINS	
θ <sub>JA</sub>	Junction-to-ambient thermal resistance	119.9	°C/W
θ <sub>JCtop</sub>	Junction-to-case (top) thermal resistance	54.5	
θ <sub>JB</sub>	Junction-to-board thermal resistance	65.0	
ψ <sub>JT</sub>	Junction-to-top characterization parameter	9.7	
ψ <sub>JB</sub>	Junction-to-board characterization parameter	n/a	
θ <sub>JCbot</sub>	Junction-to-case (bottom) thermal resistance	n/a	

(1) For more information about traditional and new thermal metrics, see the *IC Package Thermal Metrics* application report, [SPRA953](#).

## RECOMMENDED OPERATING CONDITIONS

 $T_A = -40^{\circ}\text{C}$  to  $85^{\circ}\text{C}$ 

DESCRIPTION		MIN	MAX	UNIT
VCC Voltage	5V_SUPPLY		5.5	V
IO voltage at external signal pins	Signal Pins <sup>(1)</sup>	-0.3	5.5	V
Operating free-air temperature range		-40	85	$^{\circ}\text{C}$

(1) External Signal pins are Dx+, Dx-, CTRLx, and 5V\_OUT

## ELECTRICAL CHARACTERISTICS

 $T_A = -40^{\circ}\text{C}$  to  $85^{\circ}\text{C}$  (unless otherwise noted)

PARAMETER		TEST CONDITION	MIN	TYP	MAX	UNIT
<b>LOAD SWITCH</b>						
$I_{CC}$	Supply current at 5V_SUPPLY	5V_SUPPLY = 5V, 5V_OUT = Open	6.5	7	10	$\mu\text{A}$
$I_{SC}$	Short circuit current at 5V_OUT	5V_SUPPLY = 5V, 5V_OUT = GND	100	116	147	mA
$I_{BACKDRIVE}$	Reverse leakage current at 5VOUT	5V_SUPPLY = 0V, 5V_OUT = 5V		0.01	0.69	$\mu\text{A}$
$V_{DROP}$	5V_OUT output voltage drop	5V_SUPPLY = 5V, $I_{5V\_OUT} = 55\text{ mA}$		170	205	mV
<b>CONNECTOR PINS</b>						
$V_{RWM}$	Reverse stand-off voltage				5.5	V
$V_{CLAMP}$	Clamp voltage with ESD strike	$I_{pp} = 1\text{ A}$ , 8/20 $\mu\text{s}$ <sup>(1)</sup>			13	V
		$I_{pp} = 3\text{ A}$ , 8/20 $\mu\text{s}$ <sup>(1)</sup>			15	V
$I_{IO}$	Leakage current through external signal pins <sup>(2)</sup>	5V_SUPPLY = 5V, $V_{IO} = 5\text{ V}$	2	7	65	nA
$I_{OFF}$	Current from IO Port to supply pins when powered down through signal pins <sup>(3)</sup>	5V_SUPPLY = 0 V, $V_{IO} = 2.5\text{ V}$	1	5	44	nA
$V_D$	Diode forward voltage through external signal pins <sup>(2)</sup> ; lower clamp diode	$I_D = 8\text{ mA}$	0.7	0.85	0.95	V
$R_{DYN}$	Dynamic resistance of ESD clamps external pins <sup>(3)</sup>	Pin to ground <sup>(2)</sup>		0.5		$\Omega$
$C_{IO\_TMDS}$	IO capacitance Dx+, Dx- pins to GND	5V_SUPPLY = 5 V, $V_{IO} = 2.5\text{ V}$		1		pF
$\Delta C_{IO\_TMDS}$	Differential capacitance for the Dx+, Dx- lines	5V_SUPPLY = 5 V, $V_{IO} = 2.5\text{ V}$		0.05		pF
$C_{IO\_CTRLx}$	CTRLx pin capacitance	5V_SUPPLY = 5 V, $V_{IO} = 2.5\text{ V}$		1		pF
$V_{BR}$	Break-down voltage through signal pins <sup>(3)</sup>	$I_{IO} = 1\text{ mA}$	6			V

(1) Non-repetitive current pulse 8/20  $\mu\text{s}$  exponentially decaying waveform according to IEC61000-4-5

(2) Extraction of  $R_{DYN}$  using least squares fit of TLP characteristics between  $I=1\text{A}$  AND  $I=10\text{A}$

(3) Signal pins are Dx+, Dx-, and CTRLx

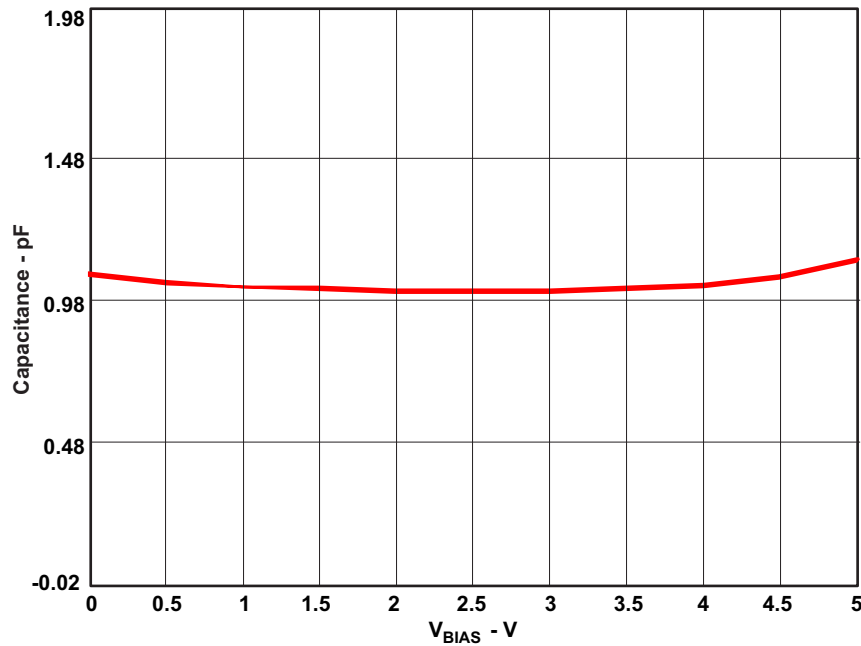

Figure 4. Pin Capacitance

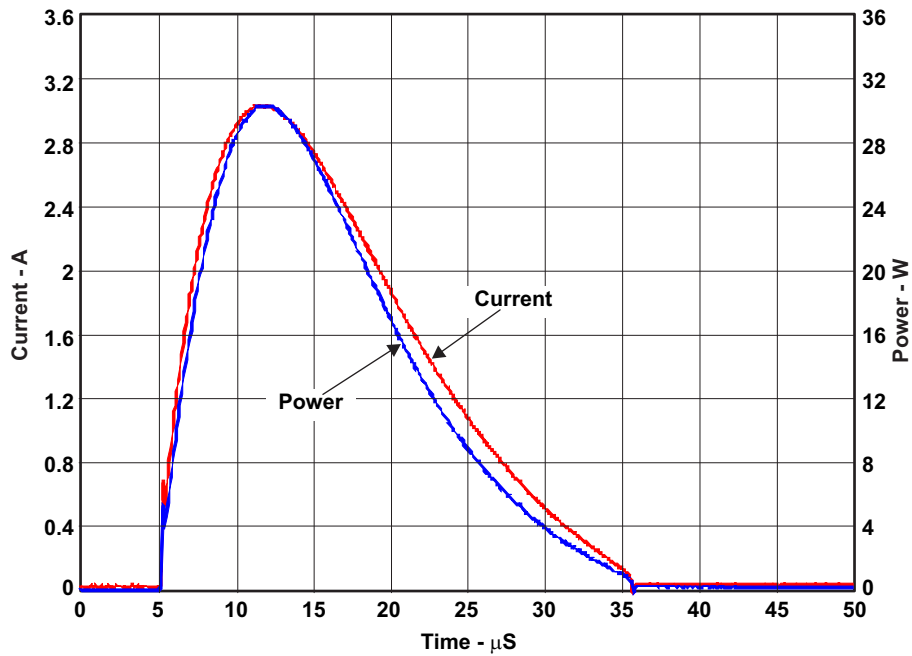

Figure 5. IEC61000-4-5 (Surge)  $I_{PP}$  and  $P_{PP}$  Waveform

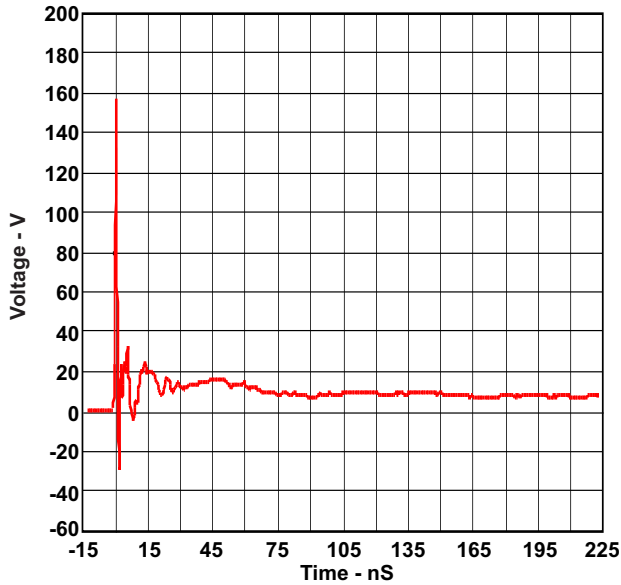

Figure 6. IEC Positive Clamping Waveform using +8kV Contact

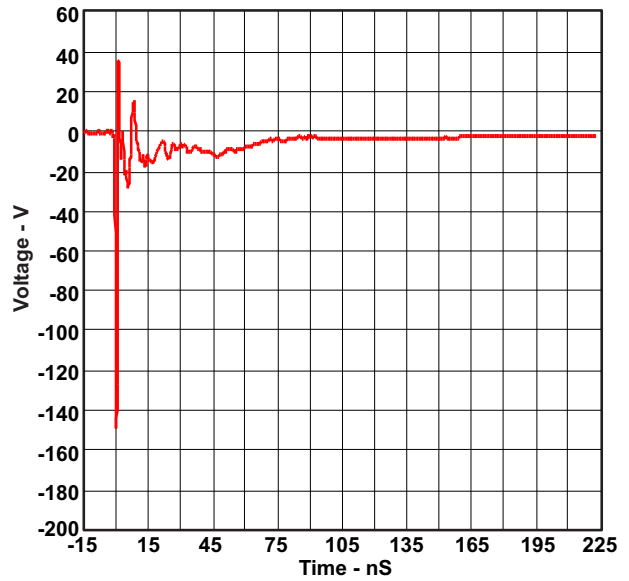

Figure 7. IEC Negative Clamping Waveform using -8kV Contact

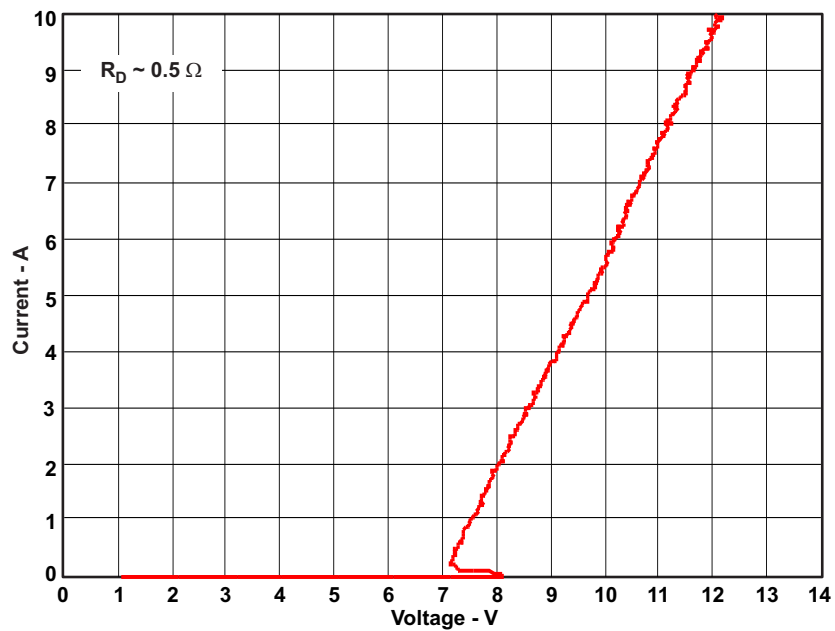

Figure 8. TLP Plot on Connector Pins

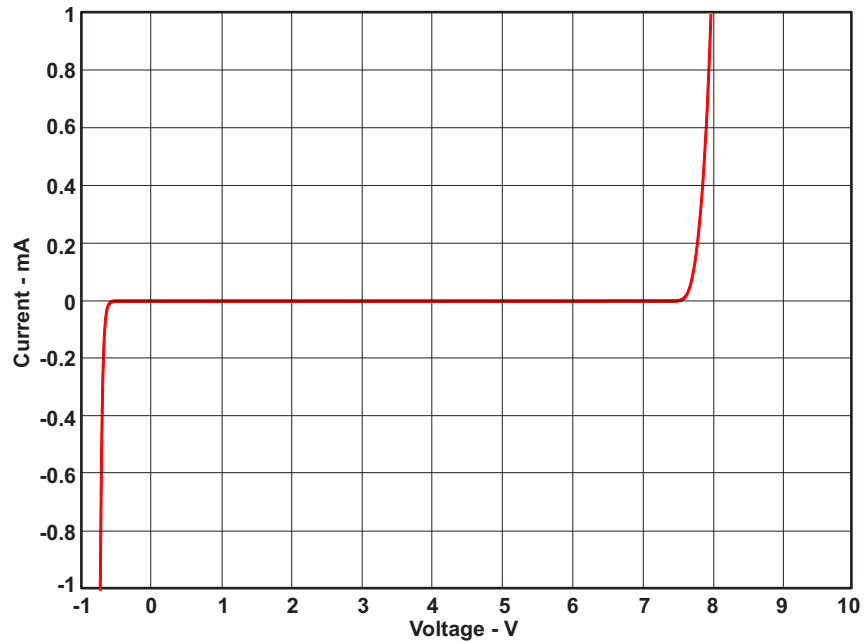

Figure 9. IV Curve on Signal Pins

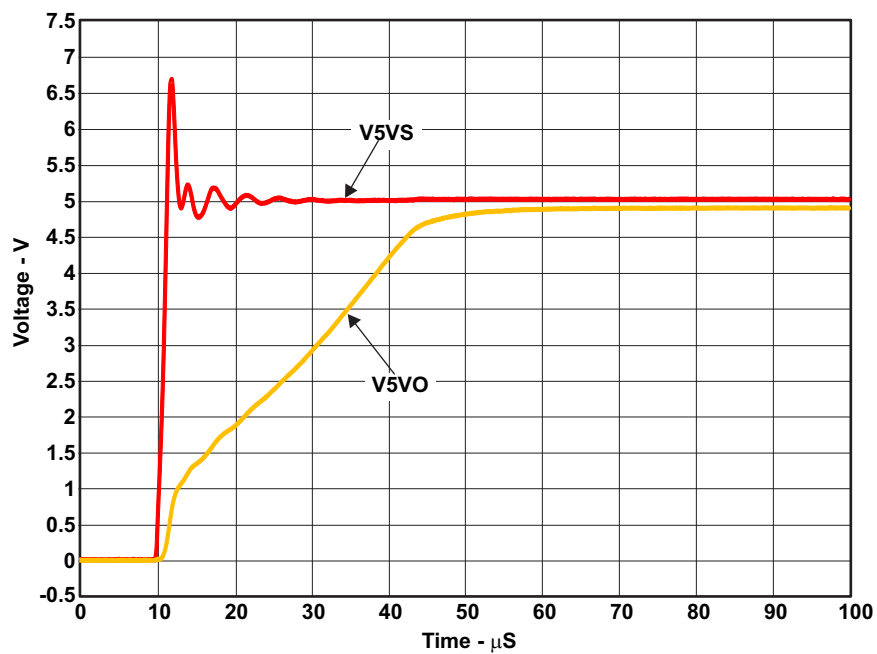

Figure 10. Load Switch Start-up Transient Waveform.  $C_{in}=1\mu F$ ,  $C_{out}=1\mu F$ ,  $I_{SWITCH}=55mA$ ,  $T_A=25^\circ C$



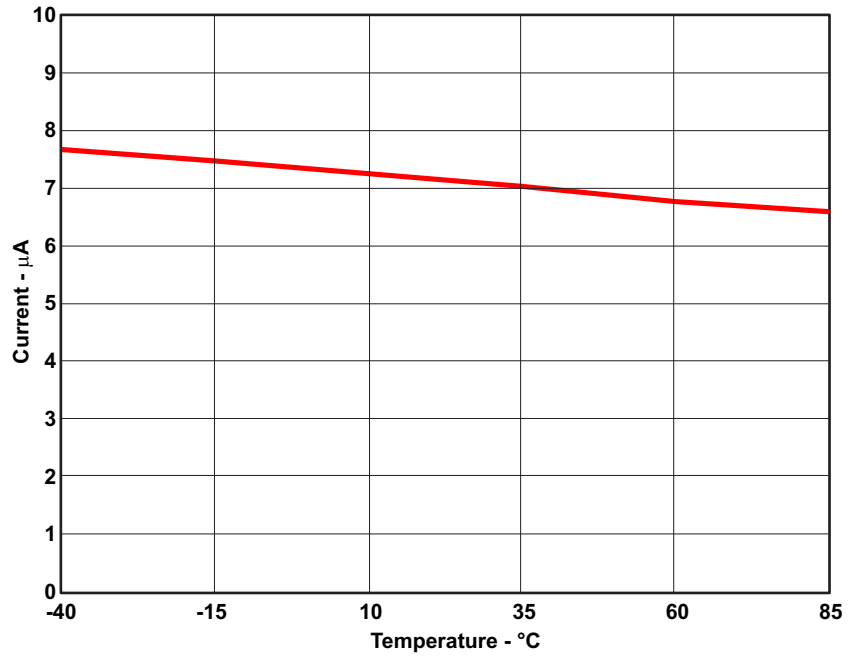

Figure 11. Load Switch Supply Current; 5V\_SUPPLY=5V, 5VOUT=open

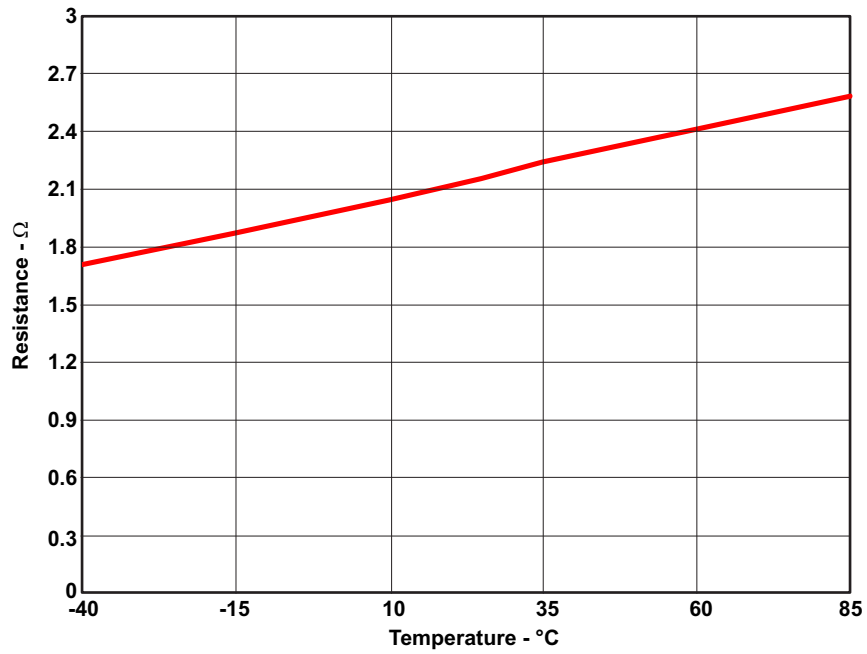

Figure 12. Load Switch Resistance vs. Temperature

TPD13S523

SLV5BC5B – MARCH 2012 – REVISED DECEMBER 2012

www.ti.com

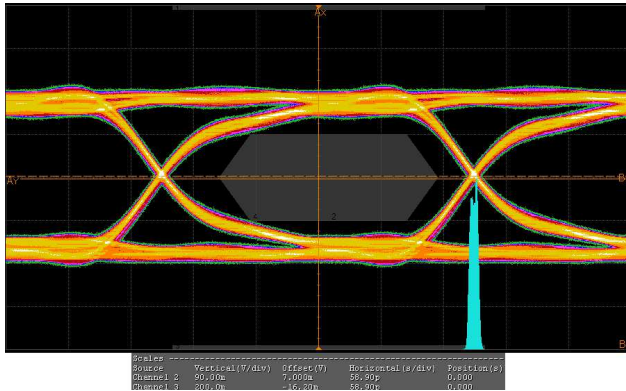

Figure 13. Eye diagram using EVM without TPD13S523 for the TMD5 Lines at 1080p, 340MHz pixel clock, 3.4Gbps

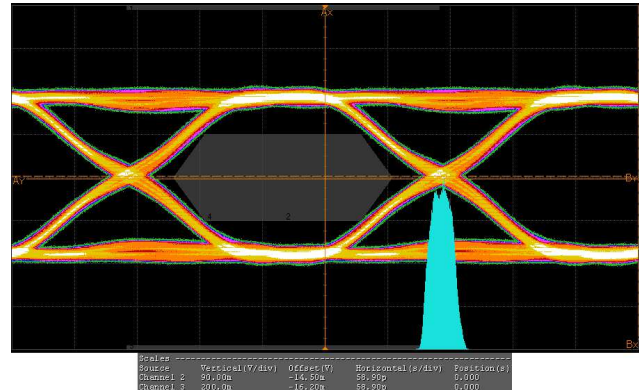

Figure 14. Eye diagram using EVM with TPD13S523 for the TMD5 Lines at 1080p, 340MHz pixel clock, 3.4Gbps

---

**REVISION HISTORY**

<b>Changes from Revision A (May 2012) to Revision B</b>	<b>Page</b>
• Removed PREVIEW status from RSV package. ....	<a href="#">1</a>
• Added RSV package to ORDERING INFORMATION table. ....	<a href="#">1</a>

---

**PACKAGING INFORMATION**

Orderable Device	Status (1)	Package Type	Package Drawing	Pins	Package Qty	Eco Plan (2)	Lead/Ball Finish	MSL Peak Temp (3)	Op Temp (°C)	Top-Side Markings (4)	Samples
TPD13S523PWR	ACTIVE	TSSOP	PW	16	2000	Green (RoHS & no Sb/Br)	CU NIPDAU	Level-1-260C-UNLIM	-40 to 85	RA523	<a href="#">Samples</a>
TPD13S523RSVR	ACTIVE	UQFN	RSV	16	3000	Green (RoHS & no Sb/Br)	CU NIPDAU	Level-1-260C-UNLIM		ZTT	<a href="#">Samples</a>

(1) The marketing status values are defined as follows:

**ACTIVE:** Product device recommended for new designs.

**LIFEBUY:** TI has announced that the device will be discontinued, and a lifetime-buy period is in effect.

**NRND:** Not recommended for new designs. Device is in production to support existing customers, but TI does not recommend using this part in a new design.

**PREVIEW:** Device has been announced but is not in production. Samples may or may not be available.

**OBSOLETE:** TI has discontinued the production of the device.

(2) Eco Plan - The planned eco-friendly classification: Pb-Free (RoHS), Pb-Free (RoHS Exempt), or Green (RoHS & no Sb/Br) - please check <http://www.ti.com/productcontent> for the latest availability information and additional product content details.

**TBD:** The Pb-Free/Green conversion plan has not been defined.

**Pb-Free (RoHS):** TI's terms "Lead-Free" or "Pb-Free" mean semiconductor products that are compatible with the current RoHS requirements for all 6 substances, including the requirement that lead not exceed 0.1% by weight in homogeneous materials. Where designed to be soldered at high temperatures, TI Pb-Free products are suitable for use in specified lead-free processes.

**Pb-Free (RoHS Exempt):** This component has a RoHS exemption for either 1) lead-based flip-chip solder bumps used between the die and package, or 2) lead-based die adhesive used between the die and leadframe. The component is otherwise considered Pb-Free (RoHS compatible) as defined above.

**Green (RoHS & no Sb/Br):** TI defines "Green" to mean Pb-Free (RoHS compatible), and free of Bromine (Br) and Antimony (Sb) based flame retardants (Br or Sb do not exceed 0.1% by weight in homogeneous material)

(3) MSL, Peak Temp. -- The Moisture Sensitivity Level rating according to the JEDEC industry standard classifications, and peak solder temperature.

(4) Multiple Top-Side Markings will be inside parentheses. Only one Top-Side Marking contained in parentheses and separated by a "~" will appear on a device. If a line is indented then it is a continuation of the previous line and the two combined represent the entire Top-Side Marking for that device.

**Important Information and Disclaimer:** The information provided on this page represents TI's knowledge and belief as of the date that it is provided. TI bases its knowledge and belief on information provided by third parties, and makes no representation or warranty as to the accuracy of such information. Efforts are underway to better integrate information from third parties. TI has taken and continues to take reasonable steps to provide representative and accurate information but may not have conducted destructive testing or chemical analysis on incoming materials and chemicals. TI and TI suppliers consider certain information to be proprietary, and thus CAS numbers and other limited information may not be available for release.

In no event shall TI's liability arising out of such information exceed the total purchase price of the TI part(s) at issue in this document sold by TI to Customer on an annual basis.

**TAPE AND REEL INFORMATION**

**QUADRANT ASSIGNMENTS FOR PIN 1 ORIENTATION IN TAPE**

\*All dimensions are nominal

Device	Package Type	Package Drawing	Pins	SPQ	Reel Diameter (mm)	Reel Width W1 (mm)	A0 (mm)	B0 (mm)	K0 (mm)	P1 (mm)	W (mm)	Pin1 Quadrant
TPD13S523PWR	TSSOP	PW	16	2000	330.0	12.4	6.9	5.6	1.6	8.0	12.0	Q1
TPD13S523RSVR	UQFN	RSV	16	3000	330.0	12.4	2.1	2.9	0.75	4.0	12.0	Q1

**TAPE AND REEL BOX DIMENSIONS**

\*All dimensions are nominal

Device	Package Type	Package Drawing	Pins	SPQ	Length (mm)	Width (mm)	Height (mm)
TPD13S523PWR	TSSOP	PW	16	2000	367.0	367.0	35.0
TPD13S523RSVR	UQFN	RSV	16	3000	180.0	180.0	30.0

PW (R-PDSO-G16)

PLASTIC SMALL OUTLINE



4040064-4/G 02/11

- NOTES:
- A. All linear dimensions are in millimeters. Dimensioning and tolerancing per ASME Y14.5M-1994.
  - B. This drawing is subject to change without notice.
  - C. Body length does not include mold flash, protrusions, or gate burrs. Mold flash, protrusions, or gate burrs shall not exceed 0,15 each side.
  - D. Body width does not include interlead flash. Interlead flash shall not exceed 0,25 each side.
  - E. Falls within JEDEC MO-153

PW (R-PDSO-G16)

PLASTIC SMALL OUTLINE



- NOTES:
- A. All linear dimensions are in millimeters.
  - B. This drawing is subject to change without notice.
  - C. Publication IPC-7351 is recommended for alternate designs.
  - D. Laser cutting apertures with trapezoidal walls and also rounding corners will offer better paste release. Customers should contact their board assembly site for stencil design recommendations. Refer to IPC-7525 for other stencil recommendations.
  - E. Customers should contact their board fabrication site for solder mask tolerances between and around signal pads.



RSV (R-PUQFN-N16)

PLASTIC QUAD FLATPACK NO-LEAD

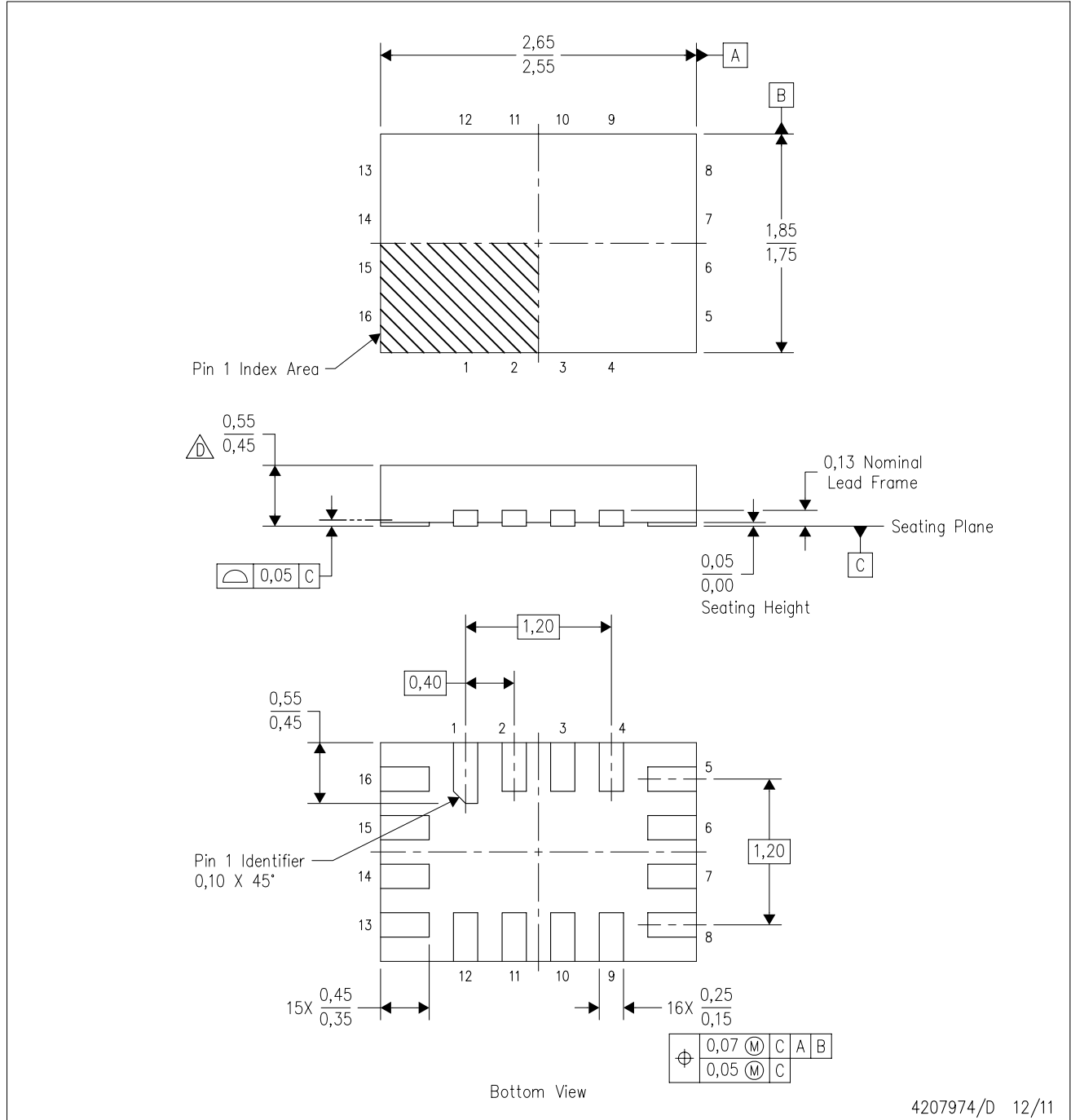

4207974/D 12/11

- NOTES:
- A. All linear dimensions are in millimeters. Dimensioning and tolerancing per ASME Y14.5M-1994.
  - B. This drawing is subject to change without notice.
  - C. QFN (Quad Flatpack No-Lead) package configuration.
  -  This package complies to JEDEC MO-288 variation UFHE, except minimum package thickness.

RSV (R-PUQFN-N16)

PLASTIC QUAD FLATPACK NO-LEAD

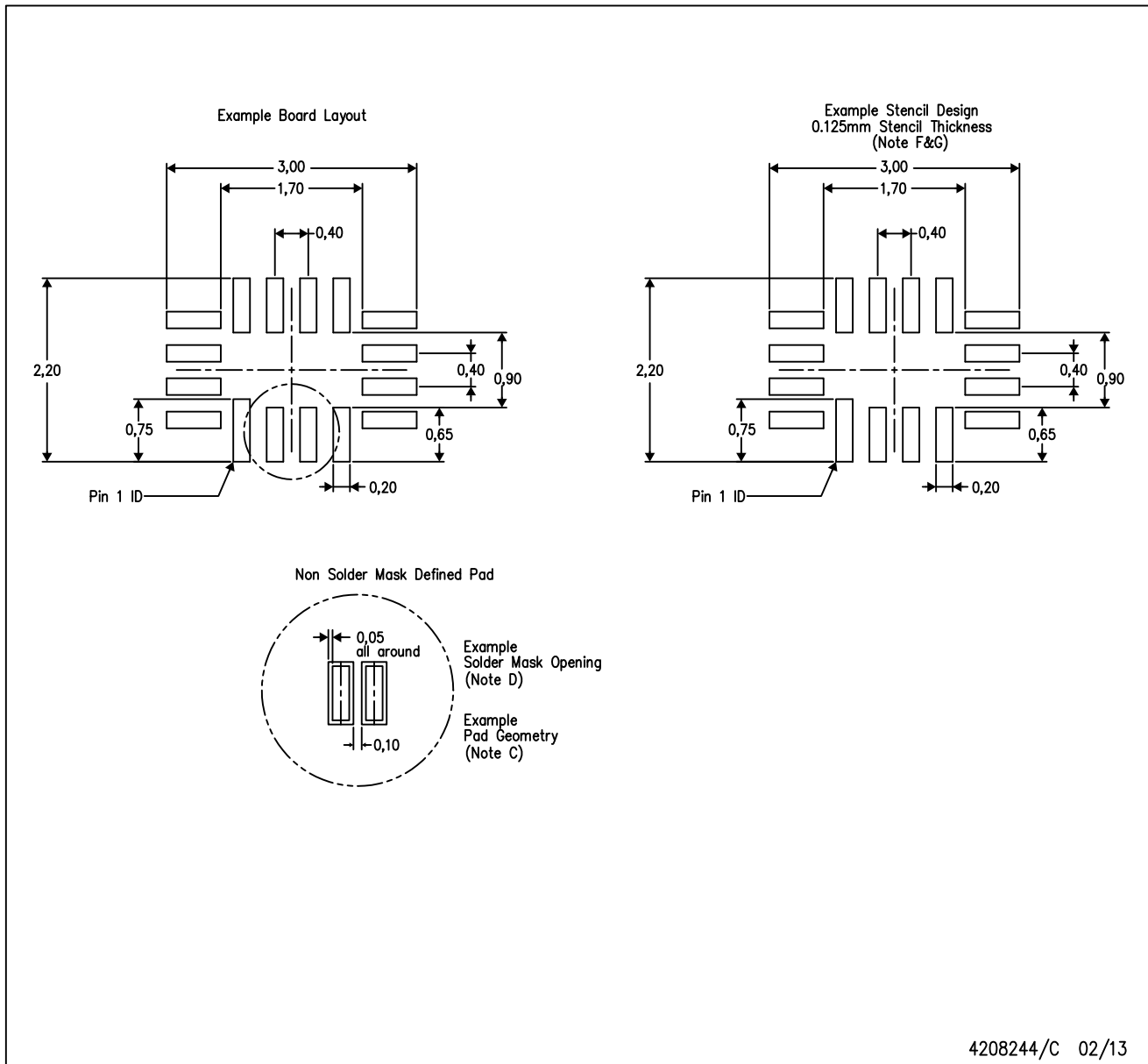

- NOTES:
- All linear dimensions are in millimeters.
  - This drawing is subject to change without notice.
  - Publication IPC-7351 is recommended for alternate designs.
  - Customers should contact their board fabrication site for minimum solder mask web tolerances between signal pads.
  - Maximum stencil thickness 0,127 mm (5 mils). All linear dimensions are in millimeters.
  - Laser cutting apertures with trapezoidal walls and also rounding corners will offer better paste release. Customers should contact their board assembly site for stencil design recommendations. Refer to IPC 7525 for stencil design considerations.
  - Side aperture dimensions over-print land for acceptable area ratio > 0.66. Customer may reduce side aperture dimensions if stencil manufacturing process allows for sufficient release at smaller opening.

## IMPORTANT NOTICE

Texas Instruments Incorporated and its subsidiaries (TI) reserve the right to make corrections, enhancements, improvements and other changes to its semiconductor products and services per JESD46, latest issue, and to discontinue any product or service per JESD48, latest issue. Buyers should obtain the latest relevant information before placing orders and should verify that such information is current and complete. All semiconductor products (also referred to herein as "components") are sold subject to TI's terms and conditions of sale supplied at the time of order acknowledgment.

TI warrants performance of its components to the specifications applicable at the time of sale, in accordance with the warranty in TI's terms and conditions of sale of semiconductor products. Testing and other quality control techniques are used to the extent TI deems necessary to support this warranty. Except where mandated by applicable law, testing of all parameters of each component is not necessarily performed.

TI assumes no liability for applications assistance or the design of Buyers' products. Buyers are responsible for their products and applications using TI components. To minimize the risks associated with Buyers' products and applications, Buyers should provide adequate design and operating safeguards.

TI does not warrant or represent that any license, either express or implied, is granted under any patent right, copyright, mask work right, or other intellectual property right relating to any combination, machine, or process in which TI components or services are used. Information published by TI regarding third-party products or services does not constitute a license to use such products or services or a warranty or endorsement thereof. Use of such information may require a license from a third party under the patents or other intellectual property of the third party, or a license from TI under the patents or other intellectual property of TI.

Reproduction of significant portions of TI information in TI data books or data sheets is permissible only if reproduction is without alteration and is accompanied by all associated warranties, conditions, limitations, and notices. TI is not responsible or liable for such altered documentation. Information of third parties may be subject to additional restrictions.

Resale of TI components or services with statements different from or beyond the parameters stated by TI for that component or service voids all express and any implied warranties for the associated TI component or service and is an unfair and deceptive business practice. TI is not responsible or liable for any such statements.

Buyer acknowledges and agrees that it is solely responsible for compliance with all legal, regulatory and safety-related requirements concerning its products, and any use of TI components in its applications, notwithstanding any applications-related information or support that may be provided by TI. Buyer represents and agrees that it has all the necessary expertise to create and implement safeguards which anticipate dangerous consequences of failures, monitor failures and their consequences, lessen the likelihood of failures that might cause harm and take appropriate remedial actions. Buyer will fully indemnify TI and its representatives against any damages arising out of the use of any TI components in safety-critical applications.

In some cases, TI components may be promoted specifically to facilitate safety-related applications. With such components, TI's goal is to help enable customers to design and create their own end-product solutions that meet applicable functional safety standards and requirements. Nonetheless, such components are subject to these terms.

No TI components are authorized for use in FDA Class III (or similar life-critical medical equipment) unless authorized officers of the parties have executed a special agreement specifically governing such use.

Only those TI components which TI has specifically designated as military grade or "enhanced plastic" are designed and intended for use in military/aerospace applications or environments. Buyer acknowledges and agrees that any military or aerospace use of TI components which have **not** been so designated is solely at the Buyer's risk, and that Buyer is solely responsible for compliance with all legal and regulatory requirements in connection with such use.

TI has specifically designated certain components as meeting ISO/TS16949 requirements, mainly for automotive use. In any case of use of non-designated products, TI will not be responsible for any failure to meet ISO/TS16949.

### Products

Audio	<a href="http://www.ti.com/audio">www.ti.com/audio</a>
Amplifiers	<a href="http://amplifier.ti.com">amplifier.ti.com</a>
Data Converters	<a href="http://dataconverter.ti.com">dataconverter.ti.com</a>
DLP® Products	<a href="http://www.dlp.com">www.dlp.com</a>
DSP	<a href="http://dsp.ti.com">dsp.ti.com</a>
Clocks and Timers	<a href="http://www.ti.com/clocks">www.ti.com/clocks</a>
Interface	<a href="http://interface.ti.com">interface.ti.com</a>
Logic	<a href="http://logic.ti.com">logic.ti.com</a>
Power Mgmt	<a href="http://power.ti.com">power.ti.com</a>
Microcontrollers	<a href="http://microcontroller.ti.com">microcontroller.ti.com</a>
RFID	<a href="http://www.ti-rfid.com">www.ti-rfid.com</a>
OMAP Applications Processors	<a href="http://www.ti.com/omap">www.ti.com/omap</a>
Wireless Connectivity	<a href="http://www.ti.com/wirelessconnectivity">www.ti.com/wirelessconnectivity</a>

### Applications

Automotive and Transportation	<a href="http://www.ti.com/automotive">www.ti.com/automotive</a>
Communications and Telecom	<a href="http://www.ti.com/communications">www.ti.com/communications</a>
Computers and Peripherals	<a href="http://www.ti.com/computers">www.ti.com/computers</a>
Consumer Electronics	<a href="http://www.ti.com/consumer-apps">www.ti.com/consumer-apps</a>
Energy and Lighting	<a href="http://www.ti.com/energy">www.ti.com/energy</a>
Industrial	<a href="http://www.ti.com/industrial">www.ti.com/industrial</a>
Medical	<a href="http://www.ti.com/medical">www.ti.com/medical</a>
Security	<a href="http://www.ti.com/security">www.ti.com/security</a>
Space, Avionics and Defense	<a href="http://www.ti.com/space-avionics-defense">www.ti.com/space-avionics-defense</a>
Video and Imaging	<a href="http://www.ti.com/video">www.ti.com/video</a>

### TI E2E Community

[e2e.ti.com](http://e2e.ti.com)