

12-V, 3-PHASE, SENSORLESS BLDC MOTOR DRIVER

Check for Samples: [DRV11873](#)

FEATURES

- Input Voltage Range 5 V to 16 V
- Six Integrated MOSFETs With 1.5-A Continuous Output Current
- Total Driver H+L $R_{\text{DS(on)}}$ 450 m Ω
- Sensorless Proprietary BEMF Control Scheme
- 150° Commutation
- Synchronous Rectification PWM Operation
- FG and RD Open Drain Output
- 5-V LDO for External Use
- PWM_{IN} Input From 15 kHz to 100 kHz
- Over Current Protection With Adjustable Limit Through External Resistor

- Lock Detection
- Voltage Surge Protection
- UVLO
- Thermal Shutdown

APPLICATIONS

- Appliance Cooling Fan
- Desktop Cooling Fan
- Server Cooling Fan

DESCRIPTION

DRV11873 is a three phase, sensorless motor driver with integrated power MOSFETs with drive current capability up to 1.5-A continuous and 2-A peak. DRV11873 is specifically designed for low noise and low external component count fan motor drive applications. DRV11873 has built in over current protection with no external current sense resistor needed. The synchronous rectification mode of operation achieves increased efficiency for motor driver applications. DRV11873 outputs FG and RD to indicate motor status with open drain output. A 150° sensorless BEMF control scheme is implemented for a three phase motor. DRV11873 is available in the thermally efficient 16-pin TSSOP package. The operation temperature is specified from -40°C to 125°C.

TYPICAL APPLICATION

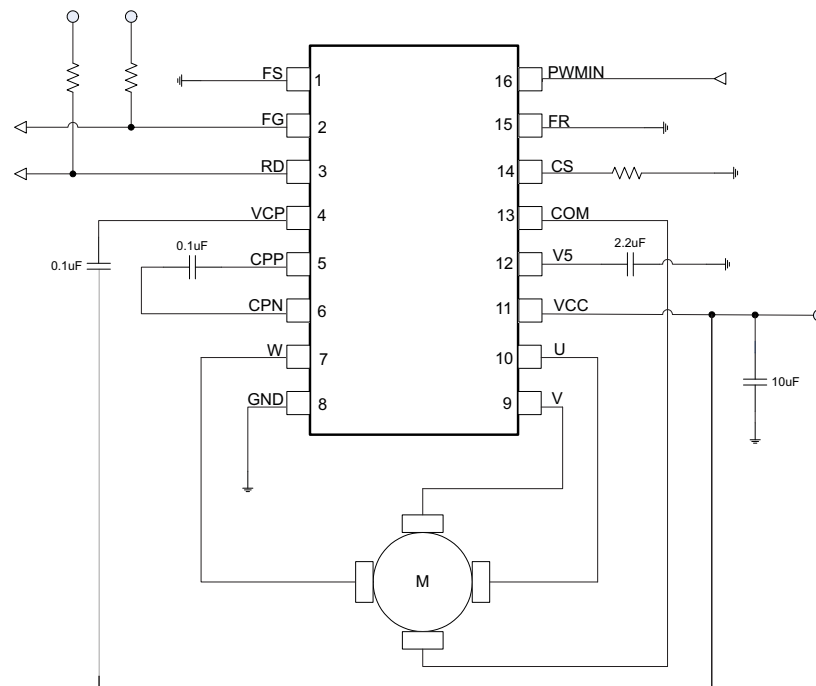

Please be aware that an important notice concerning availability, standard warranty, and use in critical applications of Texas Instruments semiconductor products and disclaimers thereto appears at the end of this data sheet.

ORDERING INFORMATION⁽¹⁾

T _A	PACKAGE ⁽²⁾		PART NUMBER	TOP-SIDE MARKING
-40°C to 125°C	TSSOP-16 (PWP)	Tape and reel, 3000	DRV11873PWP	11873

- (1) For the most current package and ordering information, see the Package Option Addendum at the end of this document, or see the TI web site at www.ti.com.
- (2) Package drawings, standard packing quantities, thermal data, symbolization, and PCB design guidelines are available at www.ti.com/package.

FUNCTIONAL BLOCK DIAGRAM

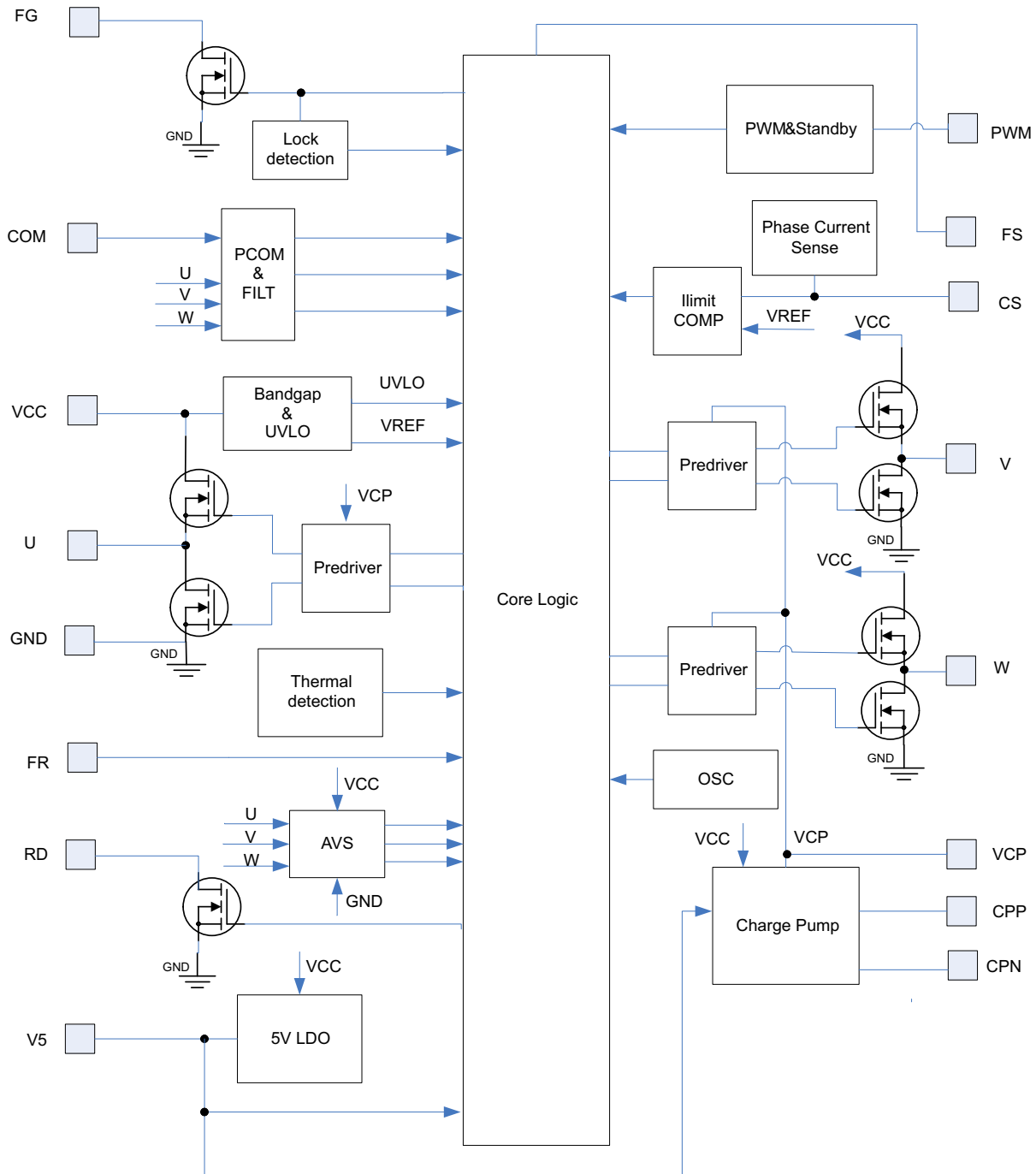

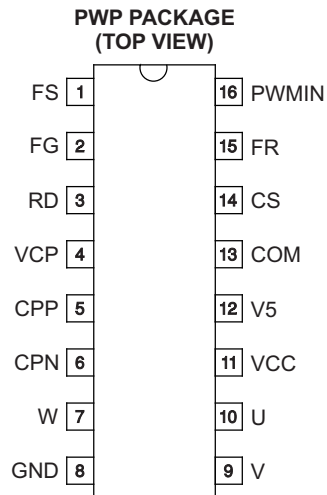
PIN DESIGNATION

Table 1. PIN DESCRIPTIONS

TERMINAL		I/O ⁽¹⁾	DESCRIPTION
NAME	NO.		
FS	1	I	Motor parameter adjustment pin. Pull low for lower speed motor and pull high for high speed motor.
FG	2	O	Frequency generator output. The output have period equal to 6 electrical states (FG).
RD	3	O	In the lock condition, RD output high through a pull up resistor to V _{CC} or 5 V.
VCP	4	O	Charge pump output
CPP	5	O	Charge pump conversion terminal
CPN	6	O	Charge pump conversion terminal
W	7	O	Phase W output
GND	8	-	Ground pin
V	9	O	Phase V output
U	10	O	Phase U output
VCC	11	I	Input voltage for motor and chip supply voltage
V5	12	O	5-V regulator output
COM	13	I	Motor common terminal input
CS	14	I	Over current threshold set up pin. A resistor set up current limit is connected between this pin and ground. The voltage across the resistor will compare with the voltage converted from the bottom MOSFETs current. If MOSFETs current is high, the part will get into the over-current protection mode by turning off top PWM MOSFET and keeping the bottom MOSFET on. $I_{limit}(A) = 6600/R_{CS}(\Omega)$, Equation valid range: 500 mA < I _{limit} < 2000 mA
FR	15	I	Set high for reverse rotation. Set low or floating for forward rotation.
PWMIN	16	I	PWM input pin. The PWM input signal will be converted to a fixed switching frequency on MOSFET driver. The PWM input signal resolution is less than 1%.

(1) I = input, O = output, N/A = not available

ABSOLUTE MAXIMUM RATINGS

over operating free-air temperature range (unless otherwise noted)

		VALUE		UNIT
		MIN	MAX	
Input voltage range	VCC	-0.3	20	V
	CS	-0.3	3.6	
	PWMIN, FS, FR	-0.3	6	
	GND	-0.3	0.3	
	COM	-1	20	
Output voltage range	U, V, W	-1	20	V
	FG, RD	-0.3	20	
	VCP	-0.3	25	
	CPN	-0.3	20	
	CPP	-0.3	25	
	V5	-0.3	6	
Electrostatic discharge (ESD)	Human body model, HBM		4	kV
	Charge device model, CBM		1	
	Machine model, MM		200	V
T _J	Operating junction temperature	-40	125	°C
T _{stg}	Storage temperature	-55	150	°C

THERMAL INFORMATION

THERMAL METRIC ⁽¹⁾		DRV11873	UNITS
		PWP	
		16 PINS	
θ_{JA}	Junction-to-ambient thermal resistance ⁽²⁾	39.4	°C/W
θ_{JCTop}	Junction-to-case (top) thermal resistance ⁽³⁾	30.3	
θ_{JB}	Junction-to-board thermal resistance ⁽⁴⁾	25.6	
ψ_{JT}	Junction-to-top characterization parameter ⁽⁵⁾	0.5	
ψ_{JB}	Junction-to-board characterization parameter ⁽⁶⁾	10.2	
θ_{JCbott}	Junction-to-case (bottom) thermal resistance ⁽⁷⁾	3.6	

- (1) For more information about traditional and new thermal metrics, see the *IC Package Thermal Metrics* application report, [SPRA953](#).
- (2) The junction-to-ambient thermal resistance under natural convection is obtained in a simulation on a JEDEC-standard, high-K board, as specified in JESD51-7, in an environment described in JESD51-2a.
- (3) The junction-to-case (top) thermal resistance is obtained by simulating a cold plate test on the package top. No specific JEDEC-standard test exists, but a close description can be found in the ANSI SEMI standard G30-88.
- (4) The junction-to-board thermal resistance is obtained by simulating in an environment with a ring cold plate fixture to control the PCB temperature, as described in JESD51-8.
- (5) The junction-to-top characterization parameter, ψ_{JT} , estimates the junction temperature of a device in a real system and is extracted from the simulation data for obtaining θ_{JA} , using a procedure described in JESD51-2a (sections 6 and 7).
- (6) The junction-to-board characterization parameter, ψ_{JB} , estimates the junction temperature of a device in a real system and is extracted from the simulation data for obtaining θ_{JA} , using a procedure described in JESD51-2a (sections 6 and 7).
- (7) The junction-to-case (bottom) thermal resistance is obtained by simulating a cold plate test on the exposed (power) pad. No specific JEDEC standard test exists, but a close description can be found in the ANSI SEMI standard G30-88.

RECOMMENDED OPERATING CONDITIONS

over operating free-air temperature range (unless otherwise noted)

		MIN	MAX	UNIT
Supply voltage	VCC	5	16	V
Voltage range	U, V, W	-0.7	17	V
	COM	-0.1	17	
	FG, RD	-0.1	16	
	PGND, GND	-0.1	0.1	
	VCP	-0.1	22	
	CPP	-0.1	22	
	CPN	-0.1	16	
	V5	-0.1	5.5	
	PWMIN, FR, FS	-0.1	5.5	
Operating junction temperature, T _J		-40	125	V

ELECTRICAL CHARACTERISTICS

Supply Current

over recommended operating free-air temperature (unless otherwise noted)

PARAMETER	TEST CONDITIONS	MIN	TYP	MAX	UNIT
I _{VCC} Supply current	T _A = 25°C; PWM = V _{CC} ; V _{CC} = 12 V		2.7	5	mA

UVLO

over recommended operating free-air temperature (unless otherwise noted)

PARAMETER	TEST CONDITIONS	MIN	TYP	MAX	UNIT
V _{UVLO-th_r} UVLO threshold voltage	Rise threshold, T _A = 25°C		4.3	4.6	V
V _{UVLO-th_f} UVLO threshold voltage	Fall threshold, T _A = 25°C	3.9	4.1		V
V _{UVLO-thhys} UVLO threshold voltage hysteresis	T _A = 25°C	100	200	300	mV

Integrated MOSFET

over recommended operating free-air temperature (unless otherwise noted)

PARAMETER	TEST CONDITIONS	MIN	TYP	MAX	UNIT
R _{DS(on)} Series resistance(H+L)	T _A = 25°C; V _{CC} = 12 V; VCP = 19 V; I _{OUT} = 1.5 A		0.45	0.6	Ω

PWM

over recommended operating free-air temperature (unless otherwise noted)

PARAMETER	TEST CONDITIONS	MIN	TYP	MAX	UNIT
V _{PWM-IH} High-level input voltage	V _{CC} ≥ 4.5 V	2.7			V
V _{PWM-IL} Low-level input voltage	V _{CC} ≥ 4.5 V			0.8	V
f _{PWM} PWM input frequency		15		100	kHz
I _{PWM-SOURCE} PWM source current		35	50	65	μA

FG

over recommended operating free-air temperature (unless otherwise noted)

PARAMETER	TEST CONDITIONS	MIN	TYP	MAX	UNIT
I _{FG-SINK} FG pin sink current	V _{FG} = 0.3 V	5			mA
I _{FG-short} FG pin short current limit	V _{FG} = 12 V		20	25	mA

RD

over recommended operating free-air temperature (unless otherwise noted)

PARAMETER		TEST CONDITIONS	MIN	TYP	MAX	UNIT
$I_{RD-SINK}$	RD pin sink current	$V_{RD} = 0.3\text{ V}$	5			mA
$I_{RD-short}$	RD pin short current limit	$V_{RD} = 12\text{ V}$		20	25	mA

FR and FS

over recommended operating free-air temperature (unless otherwise noted)

PARAMETER		TEST CONDITIONS	MIN	TYP	MAX	UNIT
V_{FR-IH}	High-level input voltage	$V_{CC} \geq 4.5\text{ V}$	2.3			V
V_{FR-IL}	Low-level input voltage	$V_{CC} \geq 4.5\text{ V}$			0.8	V
V_{FS-th}	FS set threshold voltage	$V_{CC} \geq 4.5\text{ V}$	2.3		0.8	V

V5

over recommended operating free-air temperature (unless otherwise noted)

PARAMETER		TEST CONDITIONS	MIN	TYP	MAX	UNIT
V5	5V LDO voltage	$V_{CC} = 12\text{ V}$	4.75	5	5.25	V
I_{V5}	5V LDO load current	$V_{CC} = 12\text{ V}$		20		mA

Lock Protection

over recommended operating free-air temperature (unless otherwise noted)

PARAMETER		TEST CONDITIONS	MIN	TYP	MAX	UNIT
$T_{LOCK-ON}$	Lock detect time	FS = 0	0.875	1.25	1.625	s
		FS = 1	0.437	0.625	0.812	
$T_{LOCK-OFF}$	Lock release time	FS = 0	4.375	6.25	8.125	s
		FS = 1	2.187	3.125	4.06	

Current Limit

over recommended operating free-air temperature (unless otherwise noted)

PARAMETER		TEST CONDITIONS	MIN	TYP	MAX	UNIT
Current limit		CS pin to GND resistor = 3.3 k Ω	1.7	2	2.3	A

Thermal Shutdown

over recommended operating free-air temperature (unless otherwise noted)

PARAMETER		TEST CONDITIONS	MIN	TYP	MAX	UNIT
T_{SDN}	Shut down temperature threshold	Shut down temperature		160		$^{\circ}\text{C}$
		Hysteresis		10		

DETAILED DEVICE DESCRIPTION

DRV11873 is a three phase, sensorless motor driver with integrated power MOSFETs with drive current capability up to 1.5-A continuous and 2-A peak. It is specifically designed for low noise and low external component count fan motor drive applications. DRV11873 has built in over current protection with no external current sense resistor needed. The synchronous rectification mode of operation achieves increased efficiency for motor driver applications. DRV11873 outputs FG and RD to indicate motor status with open drain output. A 150° sensorless BEMF control scheme was implemented for a three phase motor. DRV11873 can fit a wide range of fan motors with the FS pin selection function. Voltage surge protection scheme prevents the input V_{CC} capacitor from over charge during motor braking mode. DRV11873 has multiple built in protection blocks including UVLO, over current protection, lock protection and thermal shut down protection.

SPEED CONTROL

DRV11873 can control motor speed through either the PWM_{IN} or V_{CC} pin. Motor speed will increase with higher PWM_{IN} duty cycle or V_{CC} input voltage. The curve of motor speed (RPM) vs PWM_{IN} duty cycle or V_{CC} input voltage is close to linear in most cases. However, motor characteristics will affect the linearity of this speed curve. DRV11873 can operate at low V_{CC} input voltage down to 4.1 V. The PWM_{IN} pin is pulled up to V5 internally and the frequency range can vary from 15 kHz to 100 kHz. The motor driver MOSFETs will operate at constant switching frequency 125 kHz when the FS pin is pulled high and 62.5 kHz when the FS pin is pulled low. With this high switching frequency, DRV11873 can eliminate audible noise and reduce the ripple of V_{CC} input voltage and current.

FREQUENCY GENERATOR

FG output is a 50% duty square wave output in the normal operation condition. Its frequency represents the motor speed and phase information. FG pin is an open drain output. An external pull up resistor is needed to connect external system. During the start up FG output will stay at high impedance until the motor speed reaches certain level and BEMF is detected. If FG is not used, this pin can be left for floating. FG pin can be tie to either 5 V or V_{CC} through a pull up resistor. Normally the pull up resistor value can be 100 k Ω or higher. During lock protection condition, FG output will keep high until the lockout protection is dismissed and restart completed. A current limit function has been built in for FG pin. It will prevent FG open drain MOSFET get damaged in case V_{CC} or 5 V directly connected to FG pin by accident. To calculate RPM based on FG frequency, please refer to below equation.

$$RPM = \frac{(FG \times 60)}{\text{pole pairs}} \quad (1)$$

Where FG is in hertz (Hz).

FS SETTING

DRV11873 can fit a wide range of fan motors by setting the FS pin. For high speed fan motors with low motor winding resistance and low inductance, the FS pin should be pulled high. For low speed fan motors with high motor winding resistance and high inductance, the FS pin should be pulled low. Through FS pin selection, DRV11873 can be used for wide applications from low speed refrigerator cooling fans to high speed server cooling fans. FS status can only be set during device power up.

LOCK PROTECTION AND RD OUTPUT

If the motor is blocked or stopped by the external force, the lock protection will be triggered after detection time. During lock detection time, the circuit monitors FG signal. If the FG output is high during lock detection time, the lock protection will stop driving the motor. After lock release time, DRV11873 will resume driving the motor. If the lock condition is still there, DRV11873 will proceed with next lock protection cycle until the lock condition is removed. With this lock protection, the motor and device will not get over heated or be damaged. A different FS setting will determine a different lock detection and lock release time.

The RD pin is an open drain output which can be tied to either V5 or V_{CC} through a pull-up resistor. Normally the pull-up resistor value can be 100 k Ω or higher. During the lock protection condition, RD output will keep high until the lock protection is dismissed and restart completed. A current limit function has been built in for the RD pin which prevents the open drain MOSFET from damage in case V_{CC} or V5 directly connects to the RD pin.

REVERSE SPIN CONTROL FR

DRV11873 has an FR pin to set the motor for a forward spin or reverse spin. During DRV11873 power up, FR status will be set. During normal operation, the spin direction of the motor will not be changed when the FR status is changed. The FR status can be reset after the next PWM rising edge if PWM_{IN} was pulled low for 300 μ s (when the FS status is high) or 600 μ s (when the FS status is low).

5-V LDO

DRV11873 has a built-in 5-V LDO which can output a 20-mA load current. It can provide 5-V bias voltage for external use. A 2.2- μ F ceramic capacitor is recommend to connect closely on the PCB layout between V-5 pin and ground.

OVER CURRENT PROTECTION

DRV11873 can adjust over current point through the external resistor connected to CS pin and ground. Without using external current sense resistor, DRV11873 senses the current through power MOSFET. Therefore there is no power loss during the current sensing. This current sense architecture improves the system efficiency. Short CS pin to ground will disable over current protection. During over current protection, DRV11873 will only limit the current to the motor and it will not shut down the operation. The over current threshold can be set by the value of current sensing resistor through [Equation 2](#).

$$I \text{ (A)} = \frac{6600}{R_{CS} \text{ (\Omega)}} \quad (2)$$

UVLO

DRV11873 has a built-in UVLO function block. The hysteresis of UVLO threshold is 200 mV. The device will be locked out when V_{CC} reaches 4.1 V and woke up at 4.3 V.

THERMAL SHUTDOWN

DRV11873 has a built in thermal shunt down function, which will shut down the device when the junction temperature is over 160°C and will resume operating when the junction temperature drops back to 150°C.

APPLICATION INFORMATION

DRV11873 only requires 5 external components. A 10- μ F or higher ceramic capacitor connected to V_{CC} and ground is needed for decoupling purpose. During layout, the strategy of ground copper pour is very important to enhance the thermal performance. For two or more layers, eight thermal vias are needed. Refer to [Figure 1](#) for an example of PCB layout. For high speed motors (FS = 1), which need higher start up current, three Schottky diodes are needed between phases U, V, W and ground. Each diode anode terminal needs to be connected to ground and cathode terminal needs to be connected to either U or V or W.

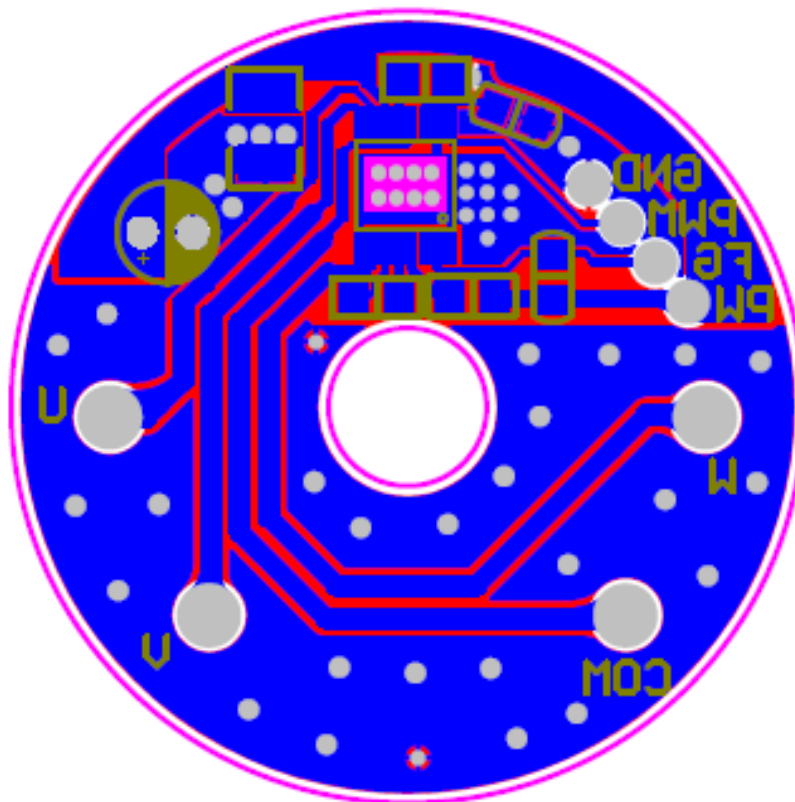

Figure 1. PCB Layout

PACKAGING INFORMATION

Orderable Device	Status (1)	Package Type	Package Drawing	Pins	Package Qty	Eco Plan (2)	Lead/Ball Finish	MSL Peak Temp (3)	Op Temp (°C)	Top-Side Markings (4)	Samples
DRV11873PWPR	ACTIVE	HTSSOP	PWP	16	2000	Green (RoHS & no Sb/Br)	CU NIPDAU	Level-2-260C-1 YEAR	-40 to 85	11873	Samples

(1) The marketing status values are defined as follows:

ACTIVE: Product device recommended for new designs.

LIFEBUY: TI has announced that the device will be discontinued, and a lifetime-buy period is in effect.

NRND: Not recommended for new designs. Device is in production to support existing customers, but TI does not recommend using this part in a new design.

PREVIEW: Device has been announced but is not in production. Samples may or may not be available.

OBSOLETE: TI has discontinued the production of the device.

(2) Eco Plan - The planned eco-friendly classification: Pb-Free (RoHS), Pb-Free (RoHS Exempt), or Green (RoHS & no Sb/Br) - please check <http://www.ti.com/productcontent> for the latest availability information and additional product content details.

TBD: The Pb-Free/Green conversion plan has not been defined.

Pb-Free (RoHS): TI's terms "Lead-Free" or "Pb-Free" mean semiconductor products that are compatible with the current RoHS requirements for all 6 substances, including the requirement that lead not exceed 0.1% by weight in homogeneous materials. Where designed to be soldered at high temperatures, TI Pb-Free products are suitable for use in specified lead-free processes.

Pb-Free (RoHS Exempt): This component has a RoHS exemption for either 1) lead-based flip-chip solder bumps used between the die and package, or 2) lead-based die adhesive used between the die and leadframe. The component is otherwise considered Pb-Free (RoHS compatible) as defined above.

Green (RoHS & no Sb/Br): TI defines "Green" to mean Pb-Free (RoHS compatible), and free of Bromine (Br) and Antimony (Sb) based flame retardants (Br or Sb do not exceed 0.1% by weight in homogeneous material)

(3) MSL, Peak Temp. -- The Moisture Sensitivity Level rating according to the JEDEC industry standard classifications, and peak solder temperature.

(4) Only one of markings shown within the brackets will appear on the physical device.

Important Information and Disclaimer: The information provided on this page represents TI's knowledge and belief as of the date that it is provided. TI bases its knowledge and belief on information provided by third parties, and makes no representation or warranty as to the accuracy of such information. Efforts are underway to better integrate information from third parties. TI has taken and continues to take reasonable steps to provide representative and accurate information but may not have conducted destructive testing or chemical analysis on incoming materials and chemicals. TI and TI suppliers consider certain information to be proprietary, and thus CAS numbers and other limited information may not be available for release.

In no event shall TI's liability arising out of such information exceed the total purchase price of the TI part(s) at issue in this document sold by TI to Customer on an annual basis.

TAPE AND REEL INFORMATION



QUADRANT ASSIGNMENTS FOR PIN 1 ORIENTATION IN TAPE



*All dimensions are nominal

Device	Package Type	Package Drawing	Pins	SPQ	Reel Diameter (mm)	Reel Width W1 (mm)	A0 (mm)	B0 (mm)	K0 (mm)	P1 (mm)	W (mm)	Pin1 Quadrant
DRV11873PWPR	HTSSOP	PWP	16	2000	330.0	12.4	6.9	5.6	1.6	8.0	12.0	Q1

TAPE AND REEL BOX DIMENSIONS



*All dimensions are nominal

Device	Package Type	Package Drawing	Pins	SPQ	Length (mm)	Width (mm)	Height (mm)
DRV11873PWPR	HTSSOP	PWP	16	2000	367.0	367.0	35.0

PWP (R-PDSO-G16)

PowerPAD™ PLASTIC SMALL OUTLINE

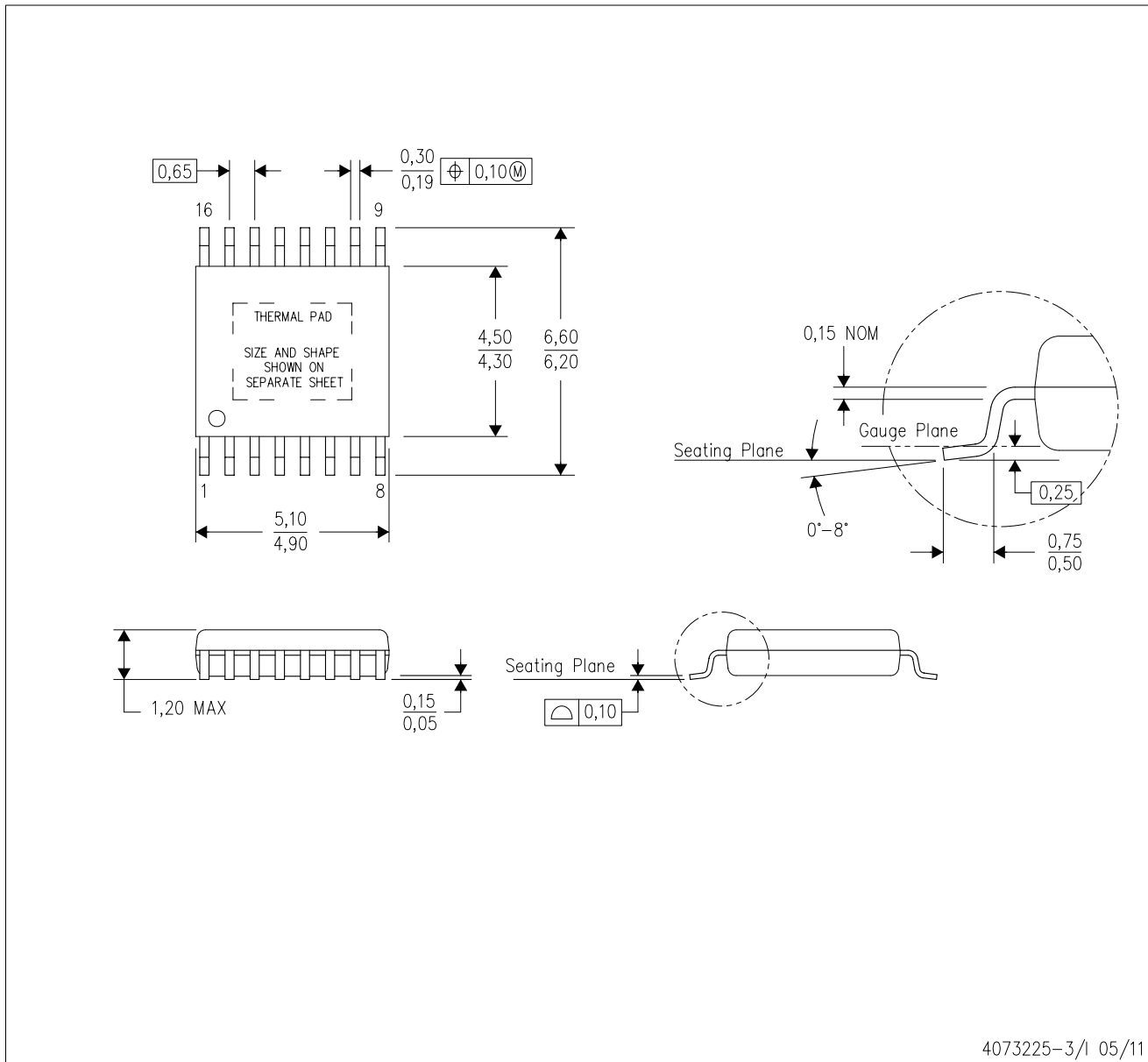

- NOTES:
- A. All linear dimensions are in millimeters.
 - B. This drawing is subject to change without notice.
 - C. Body dimensions do not include mold flash or protrusions. Mold flash and protrusion shall not exceed 0.15 per side.
 - D. This package is designed to be soldered to a thermal pad on the board. Refer to Technical Brief, PowerPad Thermally Enhanced Package, Texas Instruments Literature No. SLMA002 for information regarding recommended board layout. This document is available at www.ti.com <<http://www.ti.com>>.
 - E. See the additional figure in the Product Data Sheet for details regarding the exposed thermal pad features and dimensions.
 - E. Falls within JEDEC MO-153

PowerPAD is a trademark of Texas Instruments.

THERMAL PAD MECHANICAL DATA

PWP (R-PDSO-G16) PowerPAD™ SMALL PLASTIC OUTLINE

THERMAL INFORMATION

This PowerPAD™ package incorporates an exposed thermal pad that is designed to be attached to a printed circuit board (PCB). The thermal pad must be soldered directly to the PCB. After soldering, the PCB can be used as a heatsink. In addition, through the use of thermal vias, the thermal pad can be attached directly to the appropriate copper plane shown in the electrical schematic for the device, or alternatively, can be attached to a special heatsink structure designed into the PCB. This design optimizes the heat transfer from the integrated circuit (IC).

For additional information on the PowerPAD package and how to take advantage of its heat dissipating abilities, refer to Technical Brief, PowerPAD Thermally Enhanced Package, Texas Instruments Literature No. SLMA002 and Application Brief, PowerPAD Made Easy, Texas Instruments Literature No. SLMA004. Both documents are available at www.ti.com.

The exposed thermal pad dimensions for this package are shown in the following illustration.

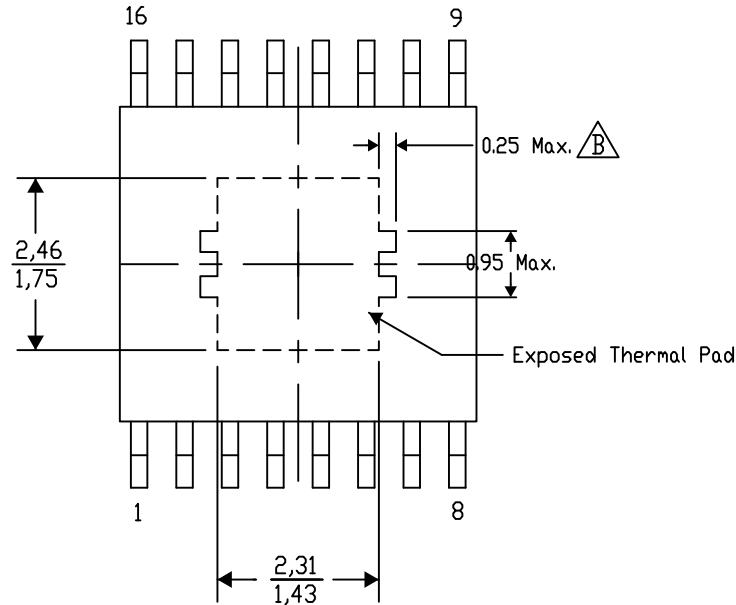

Top View

Exposed Thermal Pad Dimensions

4206332-6/AD 01/13

NOTE: A. All linear dimensions are in millimeters

$\triangle B$ Exposed tie strap features may not be present.

PowerPAD is a trademark of Texas Instruments

PWP (R-PDSO-G16)

PowerPAD™ PLASTIC SMALL OUTLINE

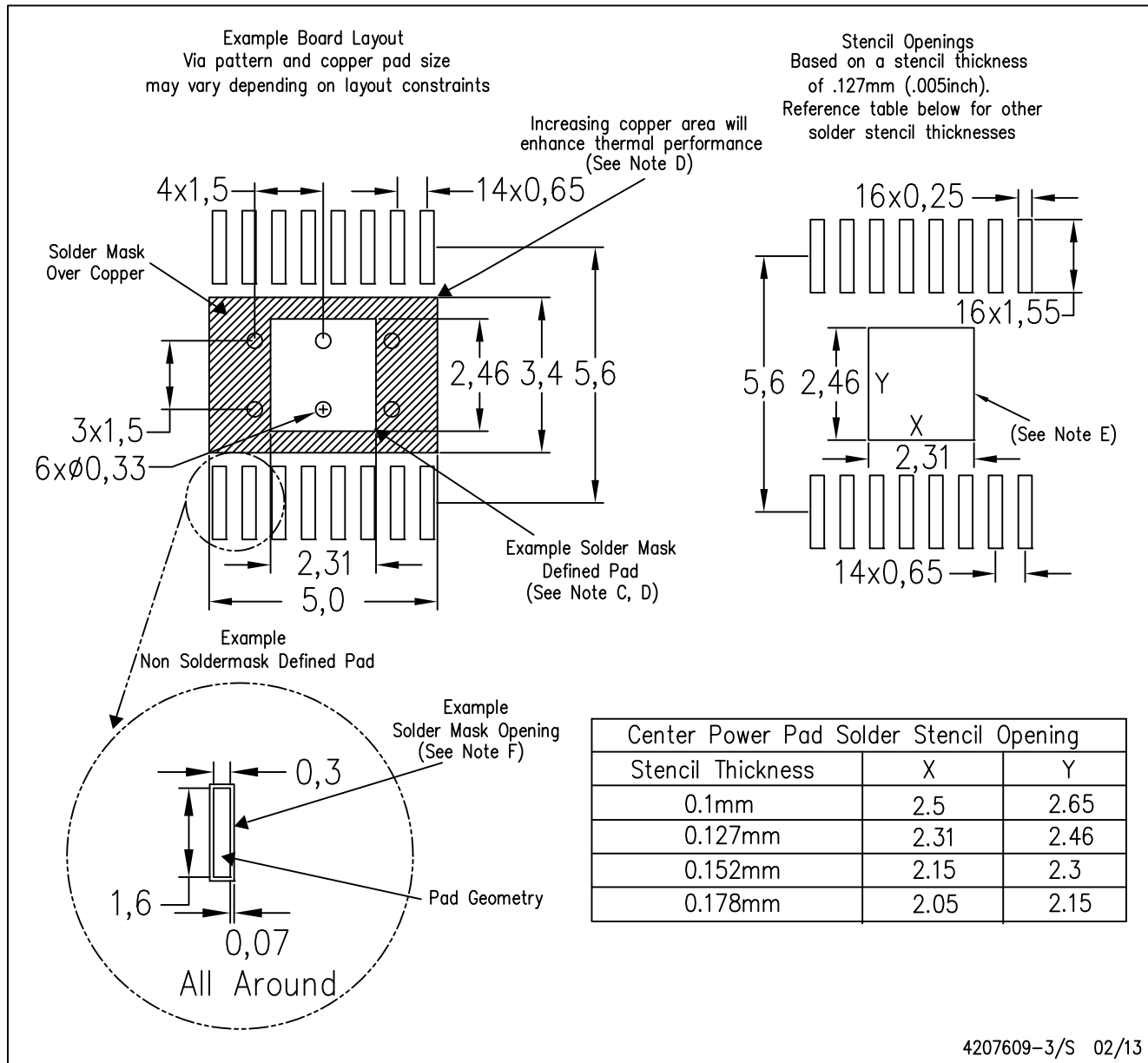

- NOTES:
- A. All linear dimensions are in millimeters.
 - B. This drawing is subject to change without notice.
 - C. Customers should place a note on the circuit board fabrication drawing not to alter the center solder mask defined pad.
 - D. This package is designed to be soldered to a thermal pad on the board. Refer to Technical Brief, PowerPad Thermally Enhanced Package, Texas Instruments Literature No. SLMA002, SLMA004, and also the Product Data Sheets for specific thermal information, via requirements, and recommended board layout. These documents are available at www.ti.com <<http://www.ti.com>>. Publication IPC-7351 is recommended for alternate designs.
 - E. Laser cutting apertures with trapezoidal walls and also rounding corners will offer better paste release. Customers should contact their board assembly site for stencil design recommendations. Example stencil design based on a 50% volumetric metal load solder paste. Refer to IPC-7525 for other stencil recommendations.
 - F. Customers should contact their board fabrication site for solder mask tolerances between and around signal pads.

IMPORTANT NOTICE

Texas Instruments Incorporated and its subsidiaries (TI) reserve the right to make corrections, enhancements, improvements and other changes to its semiconductor products and services per JESD46, latest issue, and to discontinue any product or service per JESD48, latest issue. Buyers should obtain the latest relevant information before placing orders and should verify that such information is current and complete. All semiconductor products (also referred to herein as "components") are sold subject to TI's terms and conditions of sale supplied at the time of order acknowledgment.

TI warrants performance of its components to the specifications applicable at the time of sale, in accordance with the warranty in TI's terms and conditions of sale of semiconductor products. Testing and other quality control techniques are used to the extent TI deems necessary to support this warranty. Except where mandated by applicable law, testing of all parameters of each component is not necessarily performed.

TI assumes no liability for applications assistance or the design of Buyers' products. Buyers are responsible for their products and applications using TI components. To minimize the risks associated with Buyers' products and applications, Buyers should provide adequate design and operating safeguards.

TI does not warrant or represent that any license, either express or implied, is granted under any patent right, copyright, mask work right, or other intellectual property right relating to any combination, machine, or process in which TI components or services are used. Information published by TI regarding third-party products or services does not constitute a license to use such products or services or a warranty or endorsement thereof. Use of such information may require a license from a third party under the patents or other intellectual property of the third party, or a license from TI under the patents or other intellectual property of TI.

Reproduction of significant portions of TI information in TI data books or data sheets is permissible only if reproduction is without alteration and is accompanied by all associated warranties, conditions, limitations, and notices. TI is not responsible or liable for such altered documentation. Information of third parties may be subject to additional restrictions.

Resale of TI components or services with statements different from or beyond the parameters stated by TI for that component or service voids all express and any implied warranties for the associated TI component or service and is an unfair and deceptive business practice. TI is not responsible or liable for any such statements.

Buyer acknowledges and agrees that it is solely responsible for compliance with all legal, regulatory and safety-related requirements concerning its products, and any use of TI components in its applications, notwithstanding any applications-related information or support that may be provided by TI. Buyer represents and agrees that it has all the necessary expertise to create and implement safeguards which anticipate dangerous consequences of failures, monitor failures and their consequences, lessen the likelihood of failures that might cause harm and take appropriate remedial actions. Buyer will fully indemnify TI and its representatives against any damages arising out of the use of any TI components in safety-critical applications.

In some cases, TI components may be promoted specifically to facilitate safety-related applications. With such components, TI's goal is to help enable customers to design and create their own end-product solutions that meet applicable functional safety standards and requirements. Nonetheless, such components are subject to these terms.

No TI components are authorized for use in FDA Class III (or similar life-critical medical equipment) unless authorized officers of the parties have executed a special agreement specifically governing such use.

Only those TI components which TI has specifically designated as military grade or "enhanced plastic" are designed and intended for use in military/aerospace applications or environments. Buyer acknowledges and agrees that any military or aerospace use of TI components which have **not** been so designated is solely at the Buyer's risk, and that Buyer is solely responsible for compliance with all legal and regulatory requirements in connection with such use.

TI has specifically designated certain components as meeting ISO/TS16949 requirements, mainly for automotive use. In any case of use of non-designated products, TI will not be responsible for any failure to meet ISO/TS16949.

Products

Audio	www.ti.com/audio
Amplifiers	amplifier.ti.com
Data Converters	dataconverter.ti.com
DLP® Products	www.dlp.com
DSP	dsp.ti.com
Clocks and Timers	www.ti.com/clocks
Interface	interface.ti.com
Logic	logic.ti.com
Power Mgmt	power.ti.com
Microcontrollers	microcontroller.ti.com
RFID	www.ti-rfid.com
OMAP Applications Processors	www.ti.com/omap
Wireless Connectivity	www.ti.com/wirelessconnectivity

Applications

Automotive and Transportation	www.ti.com/automotive
Communications and Telecom	www.ti.com/communications
Computers and Peripherals	www.ti.com/computers
Consumer Electronics	www.ti.com/consumer-apps
Energy and Lighting	www.ti.com/energy
Industrial	www.ti.com/industrial
Medical	www.ti.com/medical
Security	www.ti.com/security
Space, Avionics and Defense	www.ti.com/space-avionics-defense
Video and Imaging	www.ti.com/video

TI E2E Community

e2e.ti.com