

TM2CN64EFH 2097152 BY 64-BIT TM4CN64EFH 4194304 BY 64-BIT SYNCHRONOUS DYNAMIC RAM MODULES

SMMS715 – MAY 1998

- **Organization:**
 - TM2CN64EFH . . . 2 097 152 x 64 Bits
 - TM4CN64EFH . . . 4 194 304 x 64 Bits
- **Single 3.3-V Power Supply ($\pm 10\%$ Tolerance)**
- **Designed for 66-MHz 4-Clock Systems**
- **JEDEC 168-Pin Dual-In-Line Memory Module (DIMM) Without Buffer for Use With Socket**
- **TM2CN64EFH — Uses Eight 16M-Bit ($2M \times 8$ -Bit) Synchronous Dynamic RAMs (SDRAMs) in Plastic Thin Small-Outline Packages (TSOPs)**
- **TM4CN64EFH — Uses Sixteen 16M-Bit ($2M \times 8$ -Bit) SDRAMs in Plastic TSOPs**
- **Byte-Read/Write Capability**
- **Performance Ranges:**
 - **High-Speed, Low-Noise, Low-Voltage TTL (LVTTTL) Interface**
 - **Read Latencies 2 and 3 Supported**
 - **Support Burst-Interleave and Burst-Interrupt Operations**
 - **Burst Length Programmable to 1, 2, 4, and 8**
 - **Two Banks for On-Chip Interleaving (Gapless Access)**
 - **Ambient Temperature Range 0°C to 70°C**
 - **Electroless Gold-Finished Contacts**
 - **Pipeline Architecture**
 - **Serial Presence Detect (SPD) Using EEPROM**

	SYNCHRONOUS CLOCK CYCLE TIME		ACCESS TIME CLOCK TO OUTPUT		REFRESH INTERVAL
	t_{CK3} (CL = 3) [†]	t_{CK2} (CL = 2)	t_{AC3} (CL = 3)	t_{AC2} (CL = 2)	
^x CN64EFH-10	10 ns	15 ns	7.5 ns	7.5 ns	64 ms

[†] CL = CAS latency

description

The TM2CN64EFH is a 16M-byte, 168-pin dual-in-line memory module (DIMM). The DIMM is composed of eight TMS626812BDGE 2097152 x 8-bit SDRAMs, each in a 400-mil, 44-pin plastic thin small-outline package (TSOP) mounted on a substrate with decoupling capacitors. See the TMS626812B data sheet (literature number SMOS693).

The TM4CN64EFH is a 32M-byte, 168-pin DIMM. The DIMM is composed of sixteen TMS626812BDGE 2097152 x 8-bit SDRAMs, each in a 400-mil, 44-pin plastic TSOP mounted on a substrate with decoupling capacitors.

operation

The TM2CN64EFH operates as eight TMS626812BDGE devices that are connected as shown in the TM2CN64EFH functional block diagram. The TM4CN64EFH operates as sixteen TMS626812BDGE devices connected as shown in the TM4CN64EFH functional block diagram.



Please be aware that an important notice concerning availability, standard warranty, and use in critical applications of Texas Instruments semiconductor products and disclaimers thereto appears at the end of this data sheet.

PRODUCT PREVIEW information concerns products in the formative or design phase of development. Characteristic data and other specifications are design goals. Texas Instruments reserves the right to change or discontinue these products without notice.



POST OFFICE BOX 1443 • HOUSTON, TEXAS 77251-1443

Copyright © 1998, Texas Instruments Incorporated

PRODUCT PREVIEW

TM2CN64EFH 2097152 BY 64-BIT
TM4CN64EFH 4194304 BY 64-BIT
SYNCHRONOUS DYNAMIC RAM MODULES

SMMS715 – MAY 1998

**DUAL-IN-LINE MEMORY MODULE
(TOP VIEW)**

**TM2CN64EFH
(SIDE VIEW)**

**TM4CN64EFH
(SIDE VIEW)**

PIN NOMENCLATURE

A[0:10]	Row-Address Inputs
A[0:8]	Column-Address Inputs
A11/BA0	Bank-Select Zero
CAS	Column-Address Strobe
CKE[0:1]	Clock Enable
CK[0:3]	System Clock
DQ[0:63]	Data-In/Data-Out
DQMB[0:7]	Data-In/Data-Out
	Mask Enable
NC	No Connect
RAS	Row-Address Strobe
S[0:3]	Chip Select
SA[0:2]	Serial Presence Detect (SPD)
	Device Address Input
SCL	SPD Clock
SDA	SPD Address/Data
V _{DD}	3.3-V Supply
V _{SS}	Ground
WE	Write Enable
WP	Write Protect

PRODUCT PREVIEW

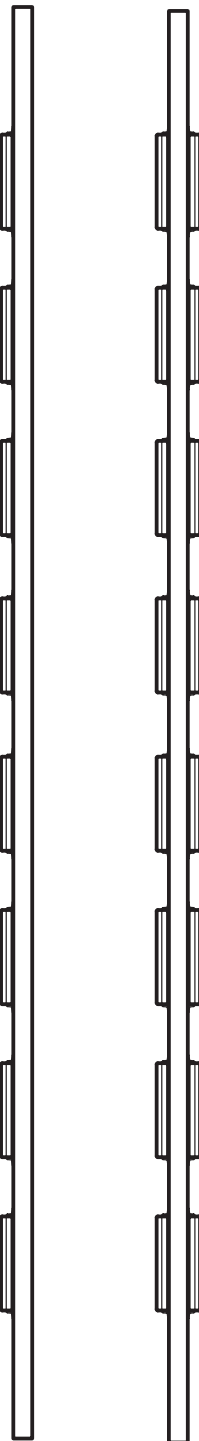
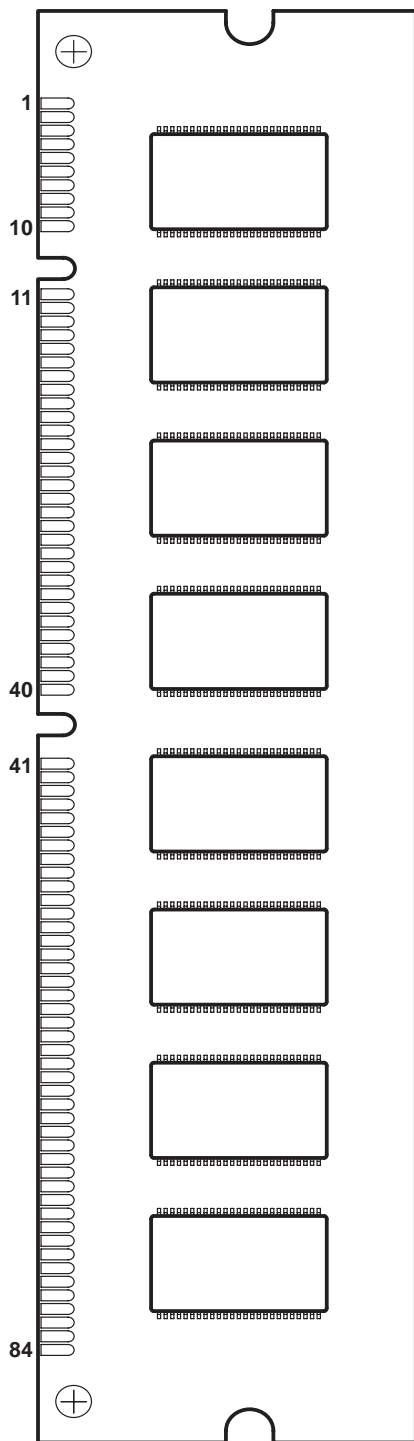

TM2CN64EFH 2097152 BY 64-BIT
TM4CN64EFH 4194304 BY 64-BIT
SYNCHRONOUS DYNAMIC RAM MODULES

SMMS715 – MAY 1998

Pin Assignments

NO.	PIN NAME	NO.	PIN NAME	NO.	PIN NAME	NO.	PIN NAME
1	V _{SS}	43	V _{SS}	85	V _{SS}	127	V _{SS}
2	DQ0	44	NC	86	DQ32	128	CKE0
3	DQ1	45	$\overline{S2}$	87	DQ33	129	$\overline{S3}$
4	DQ2	46	DQMB2	88	DQ34	130	DQMB6
5	DQ3	47	DQMB3	89	DQ35	131	DQMB7
6	V _{DD}	48	NC	90	V _{DD}	132	NC
7	DQ4	49	V _{DD}	91	DQ36	133	V _{DD}
8	DQ5	50	NC	92	DQ37	134	NC
9	DQ6	51	NC	93	DQ38	135	NC
10	DQ7	52	NC	94	DQ39	136	NC
11	DQ8	53	NC	95	DQ40	137	NC
12	V _{SS}	54	V _{SS}	96	V _{SS}	138	V _{SS}
13	DQ9	55	DQ16	97	DQ41	139	DQ48
14	DQ10	56	DQ17	98	DQ42	140	DQ49
15	DQ11	57	DQ18	99	DQ43	141	DQ50
16	DQ12	58	DQ19	100	DQ44	142	DQ51
17	DQ13	59	V _{DD}	101	DQ45	143	V _{DD}
18	V _{DD}	60	DQ20	102	V _{DD}	144	DQ52
19	DQ14	61	NC	103	DQ46	145	NC
20	DQ15	62	NC	104	DQ47	146	NC
21	NC	63	CKE1	105	NC	147	NC
22	NC	64	V _{SS}	106	NC	148	V _{SS}
23	V _{SS}	65	DQ21	107	V _{SS}	149	DQ53
24	NC	66	DQ22	108	NC	150	DQ54
25	NC	67	DQ23	109	NC	151	DQ55
26	V _{DD}	68	V _{SS}	110	V _{DD}	152	V _{SS}
27	\overline{WE}	69	DQ24	111	\overline{CAS}	153	DQ56
28	DQMB0	70	DQ25	112	DQMB4	154	DQ57
29	DQMB1	71	DQ26	113	DQMB5	155	DQ58
30	$\overline{S0}$	72	DQ27	114	$\overline{S1}$	156	DQ59
31	NC	73	V _{DD}	115	\overline{RAS}	157	V _{DD}
32	V _{SS}	74	DQ28	116	V _{SS}	158	DQ60
33	A0	75	DQ29	117	A1	159	DQ61
34	A2	76	DQ30	118	A3	160	DQ62
35	A4	77	DQ31	119	A5	161	DQ63
36	A6	78	V _{SS}	120	A7	162	V _{SS}
37	A8	79	CK2	121	A9	163	CK3
38	A10	80	NC	122	A11/BA0	164	NC
39	NC	81	WP	123	NC	165	SA0
40	V _{DD}	82	SDA	124	V _{DD}	166	SA1
41	V _{DD}	83	SCL	125	CK1	167	SA2
42	CK0	84	V _{DD}	126	NC	168	V _{DD}

PRODUCT PREVIEW



TM2CN64EFH 2097152 BY 64-BIT TM4CN64EFH 4194304 BY 64-BIT SYNCHRONOUS DYNAMIC RAM MODULES

SMMS715 – MAY 1998

dual-in-line memory module and components

The dual-in-line memory module and components include:

- PC substrate: $1,27 \pm 0,1$ mm (0.05 inch) nominal thickness; 0.005 inch/inch maximum warpage
- Bypass capacitors: Multilayer ceramic
- Contact area: Nickel plate and electroless gold-finished contacts over copper

functional block diagram for the TM2CN64EFH

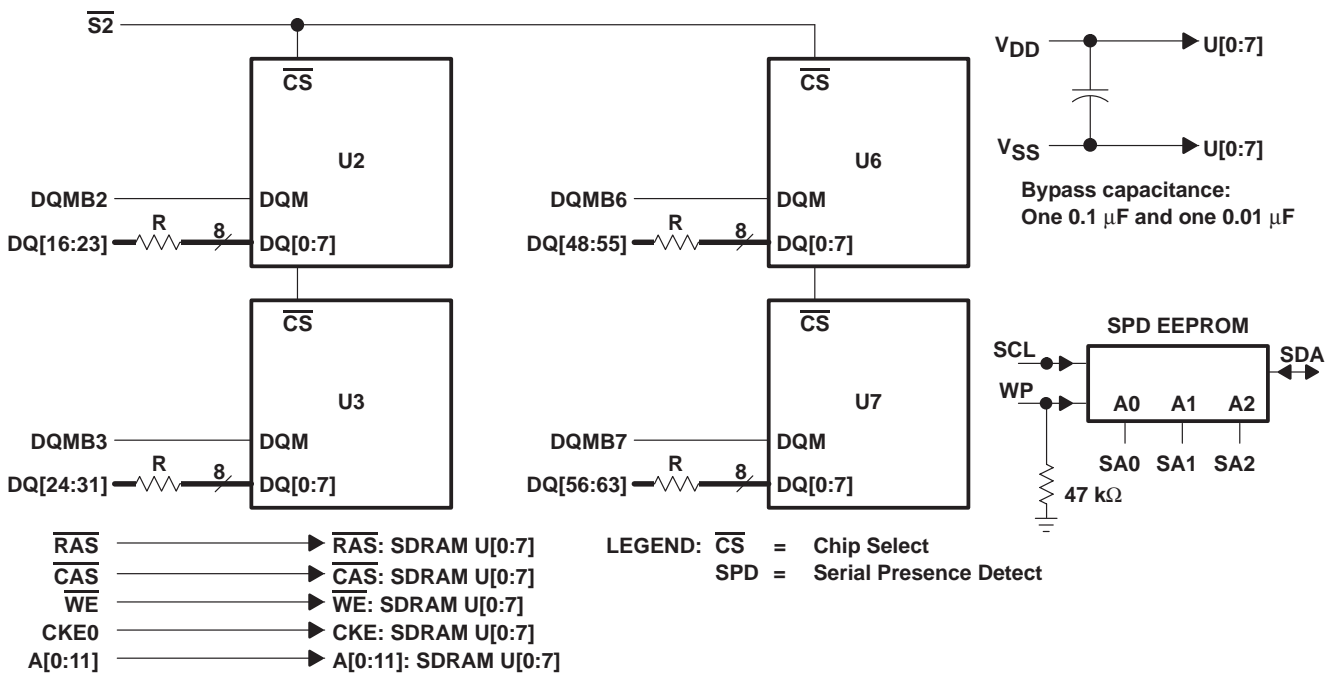
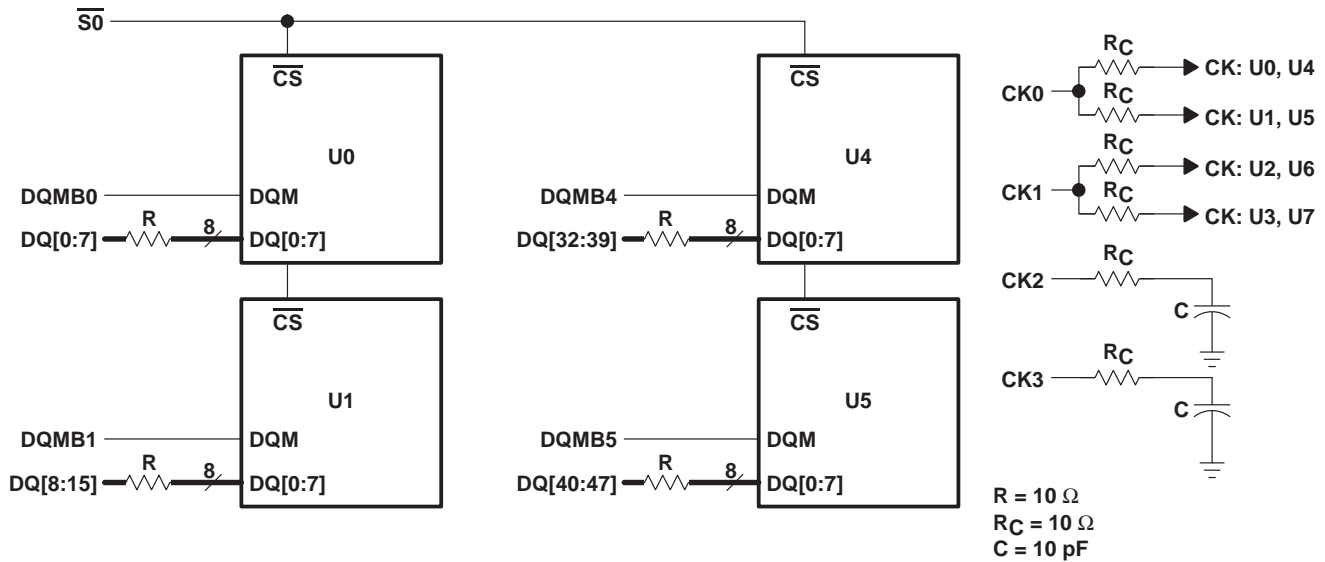

PRODUCT PREVIEW

TM2CN64EFH 2097152 BY 64-BIT TM4CN64EFH 4194304 BY 64-BIT SYNCHRONOUS DYNAMIC RAM MODULES

SMMS715 – MAY 1998

functional block diagram for the TM4CN64EFH

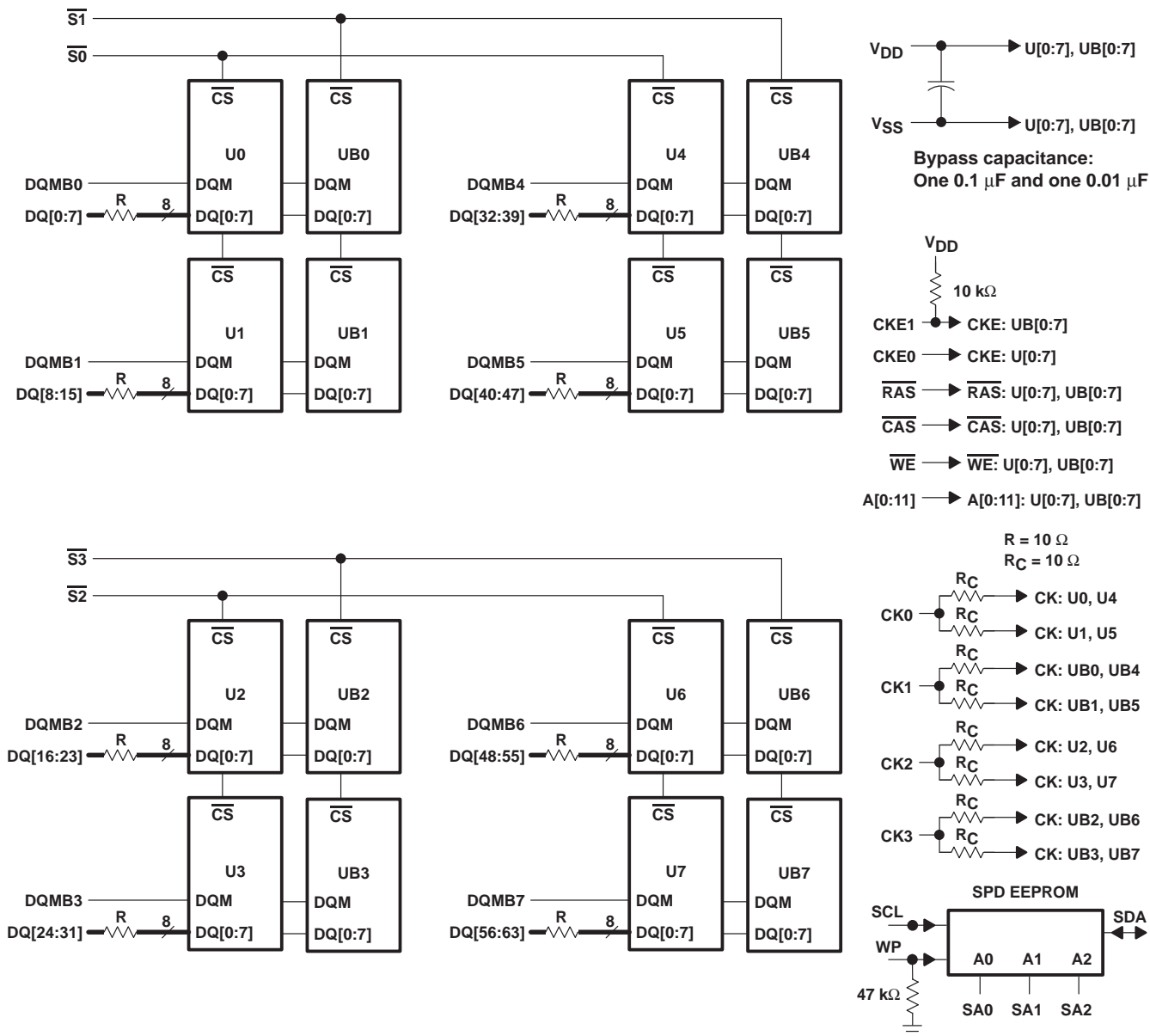

PRODUCT PREVIEW

TM2CN64EFH 2097152 BY 64-BIT
TM4CN64EFH 4194304 BY 64-BIT
SYNCHRONOUS DYNAMIC RAM MODULES

SMMS715 – MAY 1998

absolute maximum ratings over operating ambient temperature range (unless otherwise noted)†

Supply voltage range, V_{DD}	–0.5 V to 4.6 V
Voltage range on any pin (see Note 1)	– 0.5 V to 4.6 V
Short-circuit output current	50 mA
Power dissipation: TM2CN64EFH	8 W
TM4CN64EFH	16 W
Operating ambient temperature range, T_A	0°C to 70°C
Storage temperature range, T_{stg}	– 55°C to 150°C

† Stresses beyond those listed under “absolute maximum ratings” may cause permanent damage to the device. These are stress ratings only, and functional operation of the device at these or any other conditions beyond those indicated under “recommended operating conditions” is not implied. Exposure to absolute-maximum-rated conditions for extended periods may affect device reliability.

NOTE 1: All voltage values are with respect to V_{SS} .

recommended operating conditions

	MIN	NOM	MAX	UNIT
V_{DD} Supply voltage	3	3.3	3.6	V
V_{SS} Supply voltage	0			V
V_{IH} High-level input voltage	2	$V_{DD} + 0.3$		V
V_{IH-SPD} High-level input voltage for the SPD device	2	5.5		V
V_{IL} Low-level input voltage‡	–0.3	0.8		V
T_A Operating ambient temperature	0	70		°C

‡ V_{IL} MIN = –1.5 V ac (pulse width \leq 5 ns)

capacitance over recommended ranges of supply voltage and ambient temperature, $f = 1$ MHz (see Note 2)§

PARAMETER	TMxCN64EFH		UNIT
	MIN	MAX	
$C_i(CK)$ Input capacitance, CK input	2.5	4	pF
$C_i(AC)$ Input capacitance, address and control inputs: A0–A11, \overline{RAS} , \overline{CAS} , \overline{WE}	2.5	5	pF
$C_i(CKE)$ Input capacitance, CKE input	5		pF
C_o Output capacitance	4	6.5	pF
$C_i(DQMBx)$ Input capacitance, DQMBx input	2.5	5	pF
$C_i(Sx)$ Input capacitance, \overline{Sx} input	2.5	5	pF
$C_i/o(SDA)$ Input/output capacitance, SDA input	9		pF
$C_i(SPD)$ Input capacitance, SA0, SA1, SA2, SCL inputs	7		pF

§ Specifications in this table represent a single SDRAM device.

NOTE 2: $V_{DD} = 3.3$ V \pm 0.3 V. Bias on pins under test is 0 V.

PRODUCT PREVIEW



TM2CN64EFH 2097152 BY 64-BIT
TM4CN64EFH 4194304 BY 64-BIT
SYNCHRONOUS DYNAMIC RAM MODULES

SMMS715 – MAY 1998

electrical characteristics over recommended ranges of supply voltage and ambient temperature (unless otherwise noted) (see Note 3)†

PARAMETER		TEST CONDITIONS	'xCN64EFH-10		UNIT
			MIN	MAX	
V _{OH}	High-level output voltage	I _{OH} = - 2 mA	2.4		V
V _{OL}	Low-level output voltage	I _{OL} = 2 mA		0.4	V
I _I	Input current (leakage)	0 V < V _I < V _{DD} + 0.3 V, All other pins = 0 V to V _{DD}		± 10	μA
I _O	Output current (leakage)	0 V < V _O < V _{DD} , Output disabled		± 10	μA
I _{CC1}	Operating current	Burst length = 1, t _{RC} ≥ t _{RC} MIN I _{OH} /I _{OL} = 0 mA, one bank activated (see Note 4)	CAS latency = 2	85	mA
			CAS latency = 3	90	
I _{CC2P}	Precharge standby current in power-down mode	CKE ≤ V _{IL} MAX, t _{CK} = 15 ns (see Note 5)		1	mA
I _{CC2PS}		CKE and CK ≤ V _{IL} MAX, t _{CK} = ∞ (see Note 6)		1	
I _{CC2N}	Precharge standby current in non-power-down mode	CKE ≥ V _{IH} MIN, t _{CK} = 15 ns (see Note 5)		30	mA
I _{CC2NS}		CKE ≥ V _{IH} MIN, CK ≤ V _{IL} MAX, t _{CK} = ∞ (see Note 6)		2	
I _{CC3P}	Active standby current in power-down mode	CKE ≤ V _{IL} MAX, t _{CK} = 15 ns (see Note 5)		3	mA
I _{CC3PS}		CKE and CK ≤ V _{IL} MAX, t _{CK} = ∞ (see Note 6)		3	
I _{CC3N}	Active standby current in non-power-down mode	CKE ≥ V _{IH} MIN, t _{CK} = 15 ns (see Note 5)		40	mA
I _{CC3NS}		CKE ≥ V _{IH} MIN, CK ≤ V _{IL} MAX, t _{CK} = ∞ (see Note 6)		10	
I _{CC4}	Burst current	Page burst, I _{OH} /I _{OL} = 0 mA All banks activated, n _{CCD} = one cycle (see Note 7)	CAS latency = 2	130	mA
			CAS latency = 3	140	
I _{CC5}	Auto-refresh current	t _{RC} ≤ t _{RC} MIN	CAS latency = 2	80	mA
			CAS latency = 3	85	
I _{CC6}	Self-refresh current	CKE ≤ V _{IL} MAX		0.4	mA

† Specifications in this table represent a single SDRAM device.

- NOTES: 3. All specifications apply to the device after power-up initialization. All control and address inputs must be stable and valid.
4. Control, DQ, and address inputs change state twice during t_{RC}.
5. Control, DQ, and address inputs change state once every 30 ns.
6. Control, DQ, and address inputs do not change.
7. Control, DQ, and address inputs change state once every cycle.

PRODUCT PREVIEW



TM2CN64EFH 2097152 BY 64-BIT
TM4CN64EFH 4194304 BY 64-BIT
SYNCHRONOUS DYNAMIC RAM MODULES

SMMS715 – MAY 1998

ac timing requirements†

		'xCN64EFH-10		UNIT
		MIN	MAX	
t _{CK2}	Cycle time, CLK, CAS latency = 2	15		ns
t _{CK3}	Cycle time, CLK, CAS latency = 3	10		ns
t _{CH}	Pulse duration, CLK high	3		ns
t _{CL}	Pulse duration, CLK low	3		ns
t _{AC2}	Access time, CLK high to data out, CAS latency = 2 (see Note 8)		7.5	ns
t _{AC3}	Access time, CLK high to data out, CAS latency = 3 (see Note 8)		7.5	ns
t _{OH}	Hold time, CLK high to data out	3		ns
t _{LZ}	Delay time, CLK high to DQ in low-impedance state (see Note 9)	2		ns
t _{HZ}	Delay time, CLK high to DQ in high-impedance state (see Note 10)		8	ns
t _{IS}	Setup time, address, control, and data input	2		ns
t _{IH}	Hold time, address, control, and data input	1		ns
t _{CESP}	Power-down/self-refresh exit time	10		ns
t _{RAS}	Delay time, ACTV command to DEAC or DCAB command	50	100 000	ns
t _{RC}	Delay time, ACTV, REFR, or SLFR exit to ACTV, MRS, REFR, or SLFR command	80		ns
t _{RCD}	Delay time, ACTV command to READ, READ-P, WRT, or WRT-P command (see Note 11)	20		ns
t _{RP}	Delay time, DEAC or DCAB command to ACTV, MRS, REFR, or SLFR command	30		ns
t _{RRD}	Delay time, ACTV command in one bank to ACTV command in the other bank	30		ns
t _{RSA}	Delay time, MRS command to ACTV, MRS, REFR, or SLFR command	20		ns
t _{APR}	Final data out of READ-P operation to ACTV, MRS, SLFR, or REFR command	t _{RP} – (CL – 1) * t _{CK}		ns
t _{APW}	Final data in of WRT-P operation to ACTV, MRS, SLFR, or REFR command	t _{RP} + t _{CK}		ns
t _T	Transition time (see Note 12)	1	5	ns
t _{REF}	Refresh interval		64	ms
n _{CCD}	Delay time, READ or WRT command to an interrupting command	1		cycle
n _{CDD}	Delay time, CS low or high to input enabled or inhibited	0	0	cycle
n _{CLE}	Delay time, CKE high or low to CLK enabled or disabled	1	1	cycle
n _{CWL}	Delay time, final data in of WRT operation to READ, READ-P, WRT, WRT-P	1		cycle
n _{DID}	Delay time, ENBL or MASK command to enabled or masked data in	0	0	cycle
n _{DOD}	Delay time, ENBL or MASK command to enabled or masked data out	2	2	cycle
n _{HZP2}	Delay time, DEAC or DCAB command to DQ in high-impedance state, CAS latency = 2		2	cycle
n _{HZP3}	Delay time, DEAC or DCAB command to DQ in high-impedance state, CAS latency = 3		3	cycle
n _{WCD}	Delay time, WRT command to first data in	0	0	cycle
n _{WR}	Delay time, final data in of WRT operation to DEAC or DCAB command	1		cycle

† All references are made to the rising transition of CK unless otherwise noted.

NOTES: 8. t_{AC} is referenced from the rising transition of CK that precedes the data-out cycle. For example, the first data-out t_{AC} is referenced from the rising transition of CK that is CAS latency – one cycle after the READ command. Access time is measured at output reference level 1.4 V.

9. t_{LZ} is measured from the rising transition of CK that is CAS latency – one cycle after the READ command.

10. t_{HZ} MAX defines the time at which the outputs are no longer driven and is not referenced to output voltage levels.

11. For read or write operations with automatic deactivate, t_{RCD} must be set to satisfy minimum t_{RAS}.

12. Transition time, t_T, is measured between V_{IH} and V_{IL}.

PRODUCT PREVIEW



serial presence detect

The serial presence detect (SPD) is contained in a 256-byte serial EEPROM located on the module. The SPD nonvolatile EEPROM contains various data such as module configuration, SDRAM organization, and timing parameters (see Table 1 and Table 2). Only the first 128 bytes are programmed by Texas Instruments; the remaining 128 bytes are available for customer use. Programming is done through an IIC bus using the clock (SCL) and data (SDA) signals. All Texas Instruments modules comply with the current JEDEC SPD Standard. See the Texas Instruments *Serial Presence Detect Technical Reference* (literature number SMMU001) for further details.

SPD contents for the TMxCN64EFH devices are listed in the following tables:

Table 1 – TM2CN64EFH Table 2 – TM4CN64EFH

Table 1. Serial Presence Detect Data for the TM2CN64EFH

BYTE NO.	DESCRIPTION OF FUNCTION	TM2CN64EFH-10	
		ITEM	DATA
0	Defines number of bytes written into serial memory during module manufacturing	128 bytes	80h
1	Total number of bytes of SPD memory device	256 bytes	08h
2	Fundamental memory type (FPM, EDO, SDRAM, . . .)	SDRAM	04h
3	Number of row addresses on this assembly	11	0Bh
4	Number of column addresses on this assembly	9	09h
5	Number of module rows on this assembly	1 bank	01h
6	Data width of this assembly	64 bits	40h
7	Data width continuation		00h
8	Voltage interface standard of this assembly	LVTTTL	01h
9	SDRAM cycle time at maximum supported CAS latency (CL), CL = X	t _{CK} = 10 ns	A0h
10	SDRAM access from clock at CL = X	t _{AC} = 7.5 ns	75h
11	DIMM configuration type (non-parity, parity, error correcting code [ECC])	Non-Parity	00h
12	Refresh rate/type	15.6 μs/ self-refresh	80h
13	SDRAM width, primary DRAM	x8	08h
14	Error-checking SDRAM data width	N/A	00h
15	Minimum clock delay, back-to-back random column addresses	1 CK cycle	01h
16	Burst lengths supported	1, 2, 4, 8	0Fh
17	Number of banks on each SDRAM device	2 banks	02h
18	CAS latencies supported	2, 3	06h
19	CS latency	0	01h
20	Write latency	0	01h
21	SDRAM module attributes	Non-buffered/ Non-registered	00h
22	SDRAM device attributes: general	V _{DD} tolerance = (+10%), Burst read/write, precharge all, auto precharge	0Eh
23	Minimum clock cycle time at CL = X – 1	t _{CK} = 15 ns	F0h
24	Maximum data-access time from clock at CL = X – 1	t _{AC} = 7.5 ns	75h
25	Minimum clock cycle time at CL = X – 2	N/A	00h

TM2CN64EFH 2097152 BY 64-BIT
TM4CN64EFH 4194304 BY 64-BIT
SYNCHRONOUS DYNAMIC RAM MODULES

SMMS715 – MAY 1998

serial presence detect (continued)

Table 1. Serial Presence Detect Data for the TM2CN64EFH (Continued)

BYTE NO.	DESCRIPTION OF FUNCTION	TM2CN64EFH-10	
		ITEM	DATA
26	Maximum data-access time from clock at CL = X – 2	N/A	00h
27	Minimum row-precharge time	t _{RP} = 20 ns	14h
28	Minimum row-active to row-active delay	t _{RRD} = 20 ns	14h
29	Minimum <u>RAS</u> -to- <u>CAS</u> delay	t _{RCD} = 30 ns	1Eh
30	Minimum <u>RAS</u> pulse width	t _{RAS} = 50 ns	32h
31	Density of each bank on module	16M Bytes	04h
32	Command and address signal input setup time	t _{IS} = 2 ns	20h
33	Command and address signal input hold time	t _{IH} = 1 ns	10h
34	Data signal input setup time	t _{IS} = 2 ns	20h
35	Data signal input hold time	t _{IH} = 1 ns	10h
36–61	Superset features (may be used in the future)		
62	SPD revision	Rev. 1.2	12h
63	Checksum for byte 0 – 62	250	FAh
64 – 71	Manufacturer's JEDEC ID code per JEP – 106E	97h	9700...00h
72	Manufacturing location†	TBD	
73	Manufacturer's part number	T	54h
74	Manufacturer's part number	M	4Dh
75	Manufacturer's part number	2	32h
76	Manufacturer's part number	C	43h
77	Manufacturer's part number	N	4Eh
78	Manufacturer's part number	6	36h
79	Manufacturer's part number	4	34h
80	Manufacturer's part number	E	45h
81	Manufacturer's part number	F	46h
82	Manufacturer's part number	H	48h
83	Manufacturer's part number	–	2Dh
84	Manufacturer's part number	1	31h
85	Manufacturer's part number	0	30h
86–90	Manufacturer's part number	SPACE	20h
91	Die revision code†	TBD	
92	PCB revision code†	TBD	
93–94	Manufacturing date†	TBD	
95–98	Assembly serial number†	TBD	
99–125	Manufacturer-specific data†	TBD	
126	Clock frequency	66 MHz	66h
127	SDRAM component and clock interconnection details	199	C7h
128–166	System-integrator-specific data‡	TBD	
167–255	Open		

† TBD indicates that values are determined at manufacturing time and are module-dependent.

‡ These TBD values are determined and programmed by the customer (optional).

PRODUCT PREVIEW



serial presence detect (continued)

Table 2. Serial Presence Detect Data for the TM4CN64EFH

BYTE NO.	DESCRIPTION OF FUNCTION	TM4CN64EFH-10	
		ITEM	DATA
0	Defines number of bytes written into serial memory during module manufacturing	128 bytes	80h
1	Total number of bytes of SPD memory device	256 bytes	08h
2	Fundamental memory type (FPM, EDO, SDRAM, . . .)	SDRAM	04h
3	Number of row addresses on this assembly	11	0Bh
4	Number of column addresses on this assembly	9	09h
5	Number of module rows on this assembly	2	02h
6	Data width of this assembly	64 bits	40h
7	Data width continuation		00h
8	Voltage interface standard of this assembly	LVTTTL	01h
9	SDRAM cycle time at maximum supported CAS latency (CL), CL = X	t _{CK} = 10 ns	A0h
10	SDRAM access from clock at CL = X	t _{AC} = 7.5 ns	75h
11	DIMM configuration type (non-parity, parity, error correcting code [ECC])	Non-Parity	00h
12	Refresh rate/type	15.6 μs/ self-refresh	80h
13	SDRAM width, primary DRAM	x8	08h
14	Error-checking SDRAM data width	N/A	00h
15	Minimum clock delay, back-to-back random column addresses	1 CK cycle	01h
16	Burst lengths supported	1, 2, 4, 8	0Fh
17	Number of banks on each SDRAM device	2 banks	02h
18	CAS latencies supported	2, 3	06h
19	CS latency	0	01h
20	Write latency	0	01h
21	SDRAM module attributes	Non-buffered/ Non-registered	00h
22	SDRAM device attributes: general	V _{DD} tolerance = (+10%), Burst read/write, precharge all, auto precharge	0Eh
23	Minimum clock cycle time at CL = X – 1	t _{CK} = 15 ns	F0h
24	Maximum data-access time from clock at CL = X – 1	t _{AC} = 7.5 ns	75h
25	Minimum clock cycle time at CL = X – 2	N/A	00h
26	Maximum data-access time from clock at CL = X – 2	N/A	00h
27	Minimum row-precharge time	t _{RP} = 20 ns	14h
28	Minimum row-active to row-active delay	t _{RRD} = 20 ns	14h
29	Minimum $\overline{\text{RAS}}$ -to- $\overline{\text{CAS}}$ delay	t _{RCD} = 30 ns	1Eh
30	Minimum $\overline{\text{RAS}}$ pulse width	t _{RAS} = 50 ns	32h
31	Density of each bank on module	16M Bytes	04h

PRODUCT PREVIEW

TM2CN64EFH 2097152 BY 64-BIT
TM4CN64EFH 4194304 BY 64-BIT
SYNCHRONOUS DYNAMIC RAM MODULES

SMMS715 – MAY 1998

serial presence detect (continued)

Table 2. Serial Presence Detect Data for the TM4CN64EFH (Continued)

BYTE NO.	DESCRIPTION OF FUNCTION	TM4CN64EFH-10	
		ITEM	DATA
32	Command and address signal input setup time	$t_{IS} = 2 \text{ ns}$	20h
33	Command and address signal input hold time	$t_{IH} = 1 \text{ ns}$	10h
34	Data signal input setup time	$t_{IS} = 2 \text{ ns}$	20h
35	Data signal input hold time	$t_{IH} = 1 \text{ ns}$	10h
36–61	Superset features (may be used in the future)		
62	SPD revision	Rev. 1.2	12h
63	Checksum for byte 0–62	251	FBh
64–71	Manufacturer's JEDEC ID code per JEP – 106E	97h	9700...00h
72	Manufacturing location†	TBD	
73	Manufacturer's part number	T	54h
74	Manufacturer's part number	M	4Dh
75	Manufacturer's part number	4	34h
76	Manufacturer's part number	C	43h
77	Manufacturer's part number	N	4Eh
78	Manufacturer's part number	6	36h
79	Manufacturer's part number	4	34h
80	Manufacturer's part number	E	45h
81	Manufacturer's part number	F	46h
82	Manufacturer's part number	H	48h
83	Manufacturer's part number	–	2Dh
84	Manufacturer's part number	1	31h
85	Manufacturer's part number	0	30h
86–90	Manufacturer's part number	SPACE	20h
91	Die revision code†	TBD	
92	PCB revision code†	TBD	
93–94	Manufacturing date†	TBD	
95–98	Assembly serial number†	TBD	
99–125	Manufacturer-specific data†	TBD	
126	Clock frequency	66 MHz	66h
127	SDRAM component and clock interconnection details	247	F7h
128–166	System-integrator-specific data‡	TBD	
167–255	Open		

† TBD indicates that values are determined at manufacturing time and are module-dependent.

‡ These TBD values are determined and programmed by the customer (optional).

PRODUCT PREVIEW



TM2CN64EFH 2097152 BY 64-BIT
TM4CN64EFH 4194304 BY 64-BIT
SYNCHRONOUS DYNAMIC RAM MODULES

SMMS715 – MAY 1998

device symbolization (TM2CN64EFH)

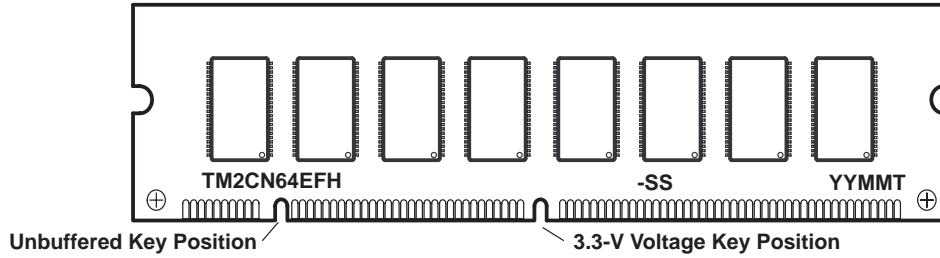

YY = Year Code
MM = Month Code
T = Assembly Site Code
-SS = Speed Code

NOTE A: Location of symbolization may vary.

PRODUCT PREVIEW

TM2CN64EFH 2097152 BY 64-BIT
TM4CN64EFH 4194304 BY 64-BIT
SYNCHRONOUS DYNAMIC RAM MODULES

SMMS715 – MAY 1998

MECHANICAL DATA

BS (R-PDIM-N168)

DUAL IN-LINE MEMORY MODULE

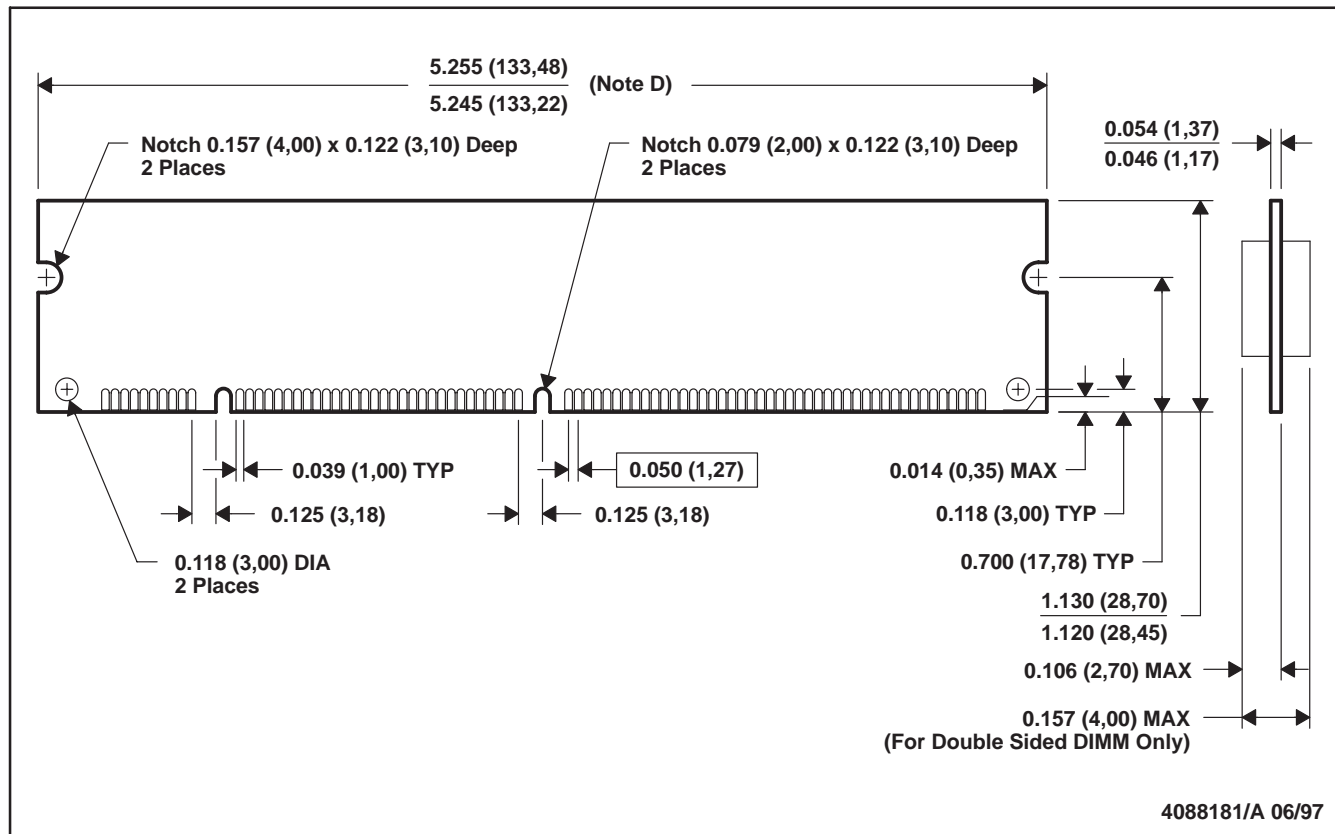

4088181/A 06/97

- NOTES: A. All linear dimensions are in inches (millimeters).
 B. This drawing is subject to change without notice.
 C. Falls within JEDEC MO-161
 D. Dimension includes De-panelization variations; applies between notch and tab edge.
 E. Outline may vary above notches to allow router/panelization irregularities.

PRODUCT PREVIEW



IMPORTANT NOTICE

Texas Instruments Incorporated and its subsidiaries (TI) reserve the right to make corrections, modifications, enhancements, improvements, and other changes to its products and services at any time and to discontinue any product or service without notice. Customers should obtain the latest relevant information before placing orders and should verify that such information is current and complete. All products are sold subject to TI's terms and conditions of sale supplied at the time of order acknowledgment.

TI warrants performance of its hardware products to the specifications applicable at the time of sale in accordance with TI's standard warranty. Testing and other quality control techniques are used to the extent TI deems necessary to support this warranty. Except where mandated by government requirements, testing of all parameters of each product is not necessarily performed.

TI assumes no liability for applications assistance or customer product design. Customers are responsible for their products and applications using TI components. To minimize the risks associated with customer products and applications, customers should provide adequate design and operating safeguards.

TI does not warrant or represent that any license, either express or implied, is granted under any TI patent right, copyright, mask work right, or other TI intellectual property right relating to any combination, machine, or process in which TI products or services are used. Information published by TI regarding third-party products or services does not constitute a license from TI to use such products or services or a warranty or endorsement thereof. Use of such information may require a license from a third party under the patents or other intellectual property of the third party, or a license from TI under the patents or other intellectual property of TI.

Reproduction of TI information in TI data books or data sheets is permissible only if reproduction is without alteration and is accompanied by all associated warranties, conditions, limitations, and notices. Reproduction of this information with alteration is an unfair and deceptive business practice. TI is not responsible or liable for such altered documentation. Information of third parties may be subject to additional restrictions.

Resale of TI products or services with statements different from or beyond the parameters stated by TI for that product or service voids all express and any implied warranties for the associated TI product or service and is an unfair and deceptive business practice. TI is not responsible or liable for any such statements.

TI products are not authorized for use in safety-critical applications (such as life support) where a failure of the TI product would reasonably be expected to cause severe personal injury or death, unless officers of the parties have executed an agreement specifically governing such use. Buyers represent that they have all necessary expertise in the safety and regulatory ramifications of their applications, and acknowledge and agree that they are solely responsible for all legal, regulatory and safety-related requirements concerning their products and any use of TI products in such safety-critical applications, notwithstanding any applications-related information or support that may be provided by TI. Further, Buyers must fully indemnify TI and its representatives against any damages arising out of the use of TI products in such safety-critical applications.

TI products are neither designed nor intended for use in military/aerospace applications or environments unless the TI products are specifically designated by TI as military-grade or "enhanced plastic." Only products designated by TI as military-grade meet military specifications. Buyers acknowledge and agree that any such use of TI products which TI has not designated as military-grade is solely at the Buyer's risk, and that they are solely responsible for compliance with all legal and regulatory requirements in connection with such use.

TI products are neither designed nor intended for use in automotive applications or environments unless the specific TI products are designated by TI as compliant with ISO/TS 16949 requirements. Buyers acknowledge and agree that, if they use any non-designated products in automotive applications, TI will not be responsible for any failure to meet such requirements.

Following are URLs where you can obtain information on other Texas Instruments products and application solutions:

Products

Amplifiers	amplifier.ti.com
Data Converters	dataconverter.ti.com
DSP	dsp.ti.com
Clocks and Timers	www.ti.com/clocks
Interface	interface.ti.com
Logic	logic.ti.com
Power Mgmt	power.ti.com
Microcontrollers	microcontroller.ti.com
RFID	www.ti-rfid.com
RF/IF and ZigBee® Solutions	www.ti.com/lprf

Applications

Audio	www.ti.com/audio
Automotive	www.ti.com/automotive
Broadband	www.ti.com/broadband
Digital Control	www.ti.com/digitalcontrol
Medical	www.ti.com/medical
Military	www.ti.com/military
Optical Networking	www.ti.com/opticalnetwork
Security	www.ti.com/security
Telephony	www.ti.com/telephony
Video & Imaging	www.ti.com/video
Wireless	www.ti.com/wireless

Mailing Address: Texas Instruments, Post Office Box 655303, Dallas, Texas 75265
Copyright © 2008, Texas Instruments Incorporated