

# LMK04800 Family Low-Noise Clock Jitter Cleaner with Dual Loop PLLs

Check for Samples: [LMK04800](#)

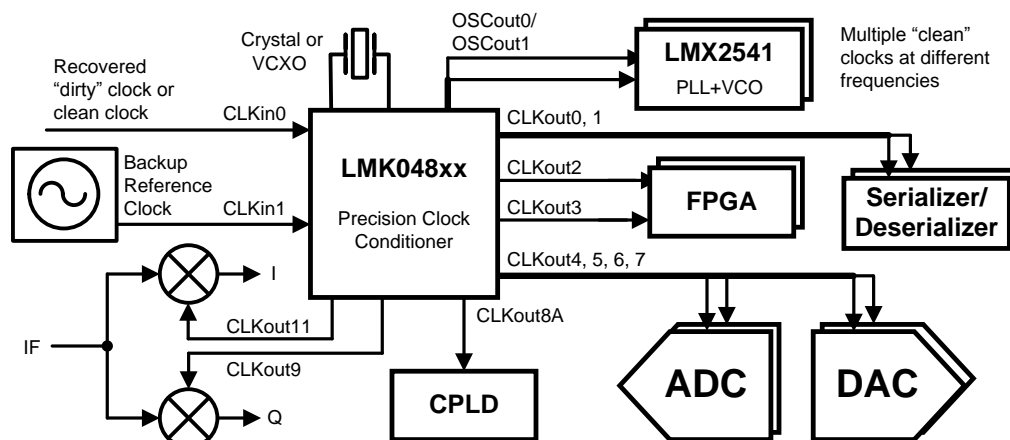
## 1 FEATURES

- **Ultra-Low RMS Jitter Performance**
  - 111 fs RMS Jitter (12 kHz to 20 MHz)
  - 123 fs RMS Jitter (100 Hz to 20 MHz)
- **Dual Loop PLLatinum™ PLL Architecture**
- **PLL1**
  - Integrated Low-Noise Crystal Oscillator Circuit
  - Holdover Mode When Input Clocks are Lost
  - Automatic or Manual Triggering/Recovery
- **PLL2**
  - Normalized PLL Noise Floor of -227 dBc/Hz
  - Phase Detector Rate up to 155 MHz
  - OSCin Frequency-Doubler
  - Integrated Low-Noise VCO
- **2 Redundant Input Clocks with LOS**
  - Automatic and Manual Switch-Over Modes
- **50% Duty Cycle Output Divides, 1 to 1045 (Even and Odd)**
- **LVPECL, LVDS, or LVCMOS Programmable Outputs**
- **Digital Delay: Fixed or Dynamically Adjustable**
- **25 ps Step Analog Delay Control.**
- **14 Differential Outputs. Up to 26 Single Ended.**
  - Up to 6 VCXO/Crystal Buffered Outputs
- **Clock Rates of up to 1536 MHz**
- **0-Delay Mode**
- **Three Default Clock Outputs at Power Up**
- **Multi-Mode: Dual PLL, Single PLL, and Clock Distribution**
- **Industrial Temperature Range: -40 to 85 °C**
- **3.15 V to 3.45 V Operation**
- **Package: 64-Pin WQFN (9.0 x 9.0 x 0.8 mm)**

### 1.1 TARGET APPLICATIONS

- **Data Converter Clocking**
- **Wireless Infrastructure**
- **Networking, SONET/SDH, DSLAM**
- **Medical / Video / Military / Aerospace**
- **Test and Measurement**

| Device    | VCO Frequency    |
|-----------|------------------|
| LMK04803B | 1840 to 2030 MHz |
| LMK04805B | 2148 to 2370 MHz |
| LMK04806B | 2370 to 2600 MHz |
| LMK04808B | 2750 to 3072 MHz |



Please be aware that an important notice concerning availability, standard warranty, and use in critical applications of Texas Instruments semiconductor products and disclaimers thereto appears at the end of this data sheet.

PLLatinum is a trademark of Texas Instruments.

All other trademarks are the property of their respective owners.

PRODUCTION DATA information is current as of publication date. Products conform to specifications per the terms of the Texas Instruments standard warranty. Production processing does not necessarily include testing of all parameters.

Copyright © 2011–2013, Texas Instruments Incorporated

## 1.2 DESCRIPTION

The LMK04800 family is the industry's highest performance clock conditioner with superior clock jitter cleaning, generation, and distribution with advanced features to meet next generation system requirements. The dual loop PLLatinum™ architecture enables 111 fs rms jitter (12 kHz to 20 MHz) using a low noise VCXO module or sub-200 fs rms jitter (12 kHz to 20 MHz) using a low cost external crystal and varactor diode.

The dual loop architecture consists of two high-performance phase-locked loops (PLL), a low-noise crystal oscillator circuit, and a high-performance voltage controlled oscillator (VCO). The first PLL (PLL1) provides a low-noise jitter cleaner function while the second PLL (PLL2) performs the clock generation. PLL1 can be configured to either work with an external VCXO module or the integrated crystal oscillator with an external tunable crystal and varactor diode. When used with a very narrow loop bandwidth, PLL1 uses the superior close-in phase noise (offsets below 50 kHz) of the VCXO module or the tunable crystal to clean the input clock. The output of PLL1 is used as the clean input reference to PLL2 where it locks the integrated VCO. The loop bandwidth of PLL2 can be optimized to clean the far-out phase noise (offsets above 50 kHz) where the integrated VCO outperforms the VCXO module or tunable crystal used in PLL1.

|          |   |                           |                         |  |                            |
|----------|---|---------------------------|-------------------------|--|----------------------------|
| <b>1</b> | <b>FEATURES</b>   | <b><a href="#">1</a></b>  | 8.1                     | SPECIAL PROGRAMMING CASE FOR R0 to R5 for CLKoutX_Y_DIV & CLKoutX_Y_DDLY | <a href="#">50</a>         |
| 1.1      | TARGET APPLICATIONS   | <a href="#">1</a>         | 8.2                     | RECOMMENDED PROGRAMMING SEQUENCE   | <a href="#">51</a>         |
| 1.2      | DESCRIPTION   | <a href="#">2</a>         | 8.3                     | READBACK   | <a href="#">52</a>         |
| <b>2</b> | <b>Device Information</b>   | <b><a href="#">4</a></b>  | 8.4                     | REGISTER MAP AND READBACK REGISTER MAP                                   | <a href="#">53</a>         |
| 2.1      | Device Configuration Information                                    | <a href="#">4</a>         | 8.5                     | DEFAULT DEVICE REGISTER SETTINGS AFTER POWER ON RESET                    | <a href="#">58</a>         |
| <b>3</b> | <b>Electrical Specifications</b>                                    | <b><a href="#">10</a></b> | 8.6                     | REGISTER R0 TO R5  | <a href="#">61</a>         |
| 3.1      | Absolute Maximum Ratings  | <a href="#">10</a>        | 8.7                     | REGISTERS R6 TO R8   | <a href="#">65</a>         |
| 3.2      | Package Thermal Resistance  | <a href="#">10</a>        | 8.8                     | REGISTER R10   | <a href="#">67</a>         |
| 3.3      | Recommended Operating Conditions                                    | <a href="#">10</a>        | 8.9                     | REGISTER R11   | <a href="#">71</a>         |
| 3.4      | Electrical Characteristics  | <a href="#">11</a>        | 8.10                    | REGISTER R12   | <a href="#">75</a>         |
| 3.5      | Serial MICROWIRE Timing Diagram                                     | <a href="#">19</a>        | 8.11                    | REGISTER R13   | <a href="#">77</a>         |
| <b>4</b> | <b>Measurement Definitions</b>                                      | <b><a href="#">21</a></b> | 8.12                    | REGISTER 14  | <a href="#">81</a>         |
| 4.1      | CHARGE PUMP CURRENT SPECIFICATION DEFINITIONS                       | <a href="#">21</a>        | 8.13                    | REGISTER 15  | <a href="#">84</a>         |
| 4.2      | DIFFERENTIAL VOLTAGE MEASUREMENT TERMINOLOGY                        | <a href="#">22</a>        | 8.14                    | REGISTER 16  | <a href="#">85</a>         |
| <b>5</b> | <b>Typical Performance Characteristics</b>                          | <b><a href="#">23</a></b> | 8.15                    | REGISTER 23  | <a href="#">85</a>         |
| 5.1      | CLOCK OUTPUT AC CHARACTERISTICS                                     | <a href="#">23</a>        | 8.16                    | REGISTER 24  | <a href="#">86</a>         |
| <b>6</b> | <b>Features</b>   | <b><a href="#">24</a></b> | 8.17                    | REGISTER 25  | <a href="#">90</a>         |
| 6.1      | SYSTEM ARCHITECTURE   | <a href="#">24</a>        | 8.18                    | REGISTER 26  | <a href="#">91</a>         |
| 6.2      | PLL1 REDUNDANT REFERENCE INPUTS (CLKin0/CLKin0* and CLKin1/CLKin1*) | <a href="#">24</a>        | 8.19                    | REGISTER 27  | <a href="#">93</a>         |
| 6.3      | PLL1 TUNABLE CRYSTAL SUPPORT  | <a href="#">24</a>        | 8.20                    | REGISTER 28  | <a href="#">95</a>         |
| 6.4      | VCXO/CRYSTAL BUFFERED OUTPUTS                                       | <a href="#">25</a>        | 8.21                    | REGISTER 29  | <a href="#">96</a>         |
| 6.5      | FREQUENCY HOLDOVER  | <a href="#">25</a>        | 8.22                    | REGISTER 30  | <a href="#">97</a>         |
| 6.6      | INTEGRATED LOOP FILTER POLES  | <a href="#">25</a>        | 8.23                    | REGISTER 31  | <a href="#">98</a>         |
| 6.7      | INTERNAL VCO  | <a href="#">25</a>        | <b>9</b>                | <b>Application Information</b>   | <b><a href="#">100</a></b> |
| 6.8      | EXTERNAL VCO MODE   | <a href="#">25</a>        | 9.1                     | FREQUENCY PLANNING WITH THE LMK04800 FAMILY                              | <a href="#">100</a>        |
| 6.9      | CLOCK DISTRIBUTION  | <a href="#">26</a>        | 9.2                     | PLL PROGRAMMING  | <a href="#">101</a>        |
| 6.10     | 0-DELAY   | <a href="#">27</a>        | 9.3                     | LOOP FILTER  | <a href="#">102</a>        |
| 6.11     | DEFAULT STARTUP CLOCKS  | <a href="#">27</a>        | 9.4                     | SYSTEM LEVEL DIAGRAM   | <a href="#">104</a>        |
| 6.12     | STATUS PINS   | <a href="#">27</a>        | 9.5                     | PIN CONNECTION RECOMMENDATIONS   | <a href="#">106</a>        |
| 6.13     | REGISTER READBACK   | <a href="#">27</a>        | 9.6                     | DIGITAL LOCK DETECT FREQUENCY ACCURACY                                   | <a href="#">108</a>        |
| <b>7</b> | <b>Functional Description</b>                                       | <b><a href="#">28</a></b> | 9.7                     | CALCULATING DYNAMIC DIGITAL DELAY VALUES FOR ANY DIVIDE                  | <a href="#">108</a>        |
| 7.1      | FUNCTIONAL OVERVIEW   | <a href="#">28</a>        | 9.8                     | OPTIONAL CRYSTAL OSCILLATOR IMPLEMENTATION (OSCin/OSCin*)                | <a href="#">111</a>        |
| 7.2      | MODE SELECTION  | <a href="#">29</a>        | 9.9                     | DRIVING CLKin AND OSCin INPUTS   | <a href="#">116</a>        |
| 7.3      | INPUTS / OUTPUTS  | <a href="#">30</a>        | 9.10                    | TERMINATION AND USE OF CLOCK OUTPUT (DRIVERS)                            | <a href="#">117</a>        |
| 7.4      | INPUT CLOCK SWITCHING   | <a href="#">30</a>        | 9.11                    | POWER SUPPLY   | <a href="#">121</a>        |
| 7.5      | HOLDOVER MODE   | <a href="#">33</a>        | 9.12                    | THERMAL MANAGEMENT   | <a href="#">124</a>        |
| 7.6      | PLLs  | <a href="#">35</a>        | <b>Revision History</b> |  | <b><a href="#">125</a></b> |
| 7.7      | STATUS PINS   | <a href="#">36</a>        |                         |  |                            |
| 7.8      | VCO   | <a href="#">37</a>        |                         |  |                            |
| 7.9      | CLOCK DISTRIBUTION  | <a href="#">38</a>        |                         |  |                            |
| <b>8</b> | <b>General Programming Information</b>                              | <b><a href="#">50</a></b> |                         |  |                            |

## 2 Device Information

### 2.1 Device Configuration Information

| NSID         | Reference Inputs | Dedicated Buffered/Divided OSCin Clock | Programmable LVDS/LVPECL/LVCMOS Outputs <sup>(1)</sup> | VCO              |
|--------------|------------------|--|--|------------------|
| LMK04803BISQ | 2                | 2                                      | 12   | 1840 to 2030 MHz |
| LMK04805BISQ | 2                | 2                                      | 12   | 2148 to 2370 MHz |
| LMK04806BISQ | 2                | 2                                      | 12   | 2370 to 2600 MHz |
| LMK04808BISQ | 2                | 2                                      | 12   | 2750 to 3072 MHz |

(1) Up to 4 of these outputs are also able to be driven by the OSCin clock.

#### 2.1.1 Functional Block Diagrams and Operating Modes

The LMK048xx is a flexible device that can be configured for many different use cases. The following simplified block diagrams help show the user the different use cases of the device.

##### 2.1.1.1 Dual PLL

Figure 2-1 illustrates the typical use case of the LMK048xx in dual loop mode. In dual loop mode the reference to PLL1 is either CLKin0 or CLKin1. An external VCXO or tunable crystal will be used to provide feedback for the first PLL and a reference to the second PLL. This first PLL cleans the jitter with the VCXO or low cost tunable crystal by using a narrow loop bandwidth. The VCXO or tunable crystal output may be buffered through the two OSCout ports and optionally on up to 4 of the CLKouts. The VCXO or tunable crystal is used as the reference to PLL2 and may be doubled using the frequency doubler. The internal VCO drives up to six divide/delay blocks which drive 12 clock outputs.

Holdover functionality is optionally available when the input reference clock is lost. Holdover works by fixing the tuning voltage of PLL1 to the VCXO or tunable crystal.

It is also possible to use an external VCO in place of PLL2's internal VCO.

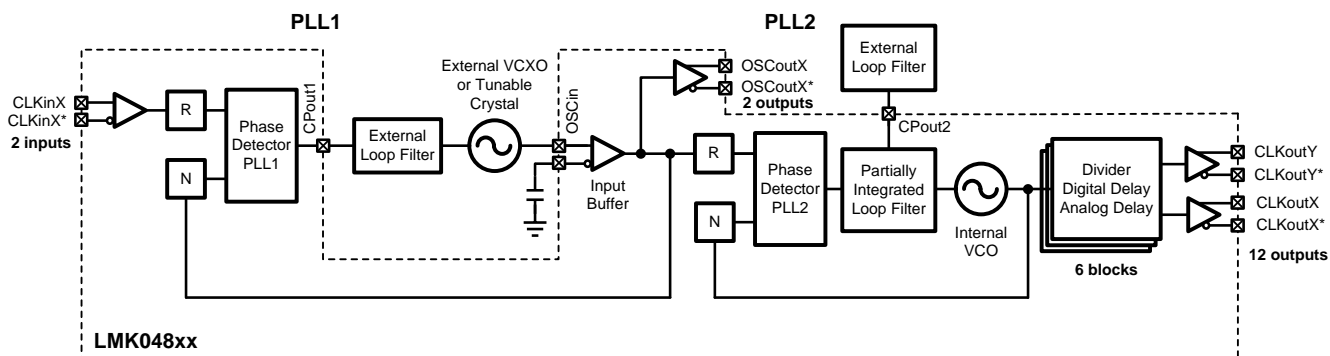


Figure 2-1. Simplified Functional Block Diagram for Dual Loop Mode

### 2.1.1.2 0-Delay Dual PLL

Figure 2-2 illustrates the use case of 0-delay dual loop mode. This configuration is very similar to Section 2.1.1.1 except that the feedback to the first PLL is driven by a clock output. This causes the clock outputs to have deterministic phase with the clock input. Since all the clock outputs can be synchronized together, all the clock outputs can be in phase with the clock input signal. The feedback to PLL1 can be connected internally as shown, or externally using FBCLKin (CLKin1) as an input port.

It is also possible to use an external VCO in place of PLL2's internal VCO.

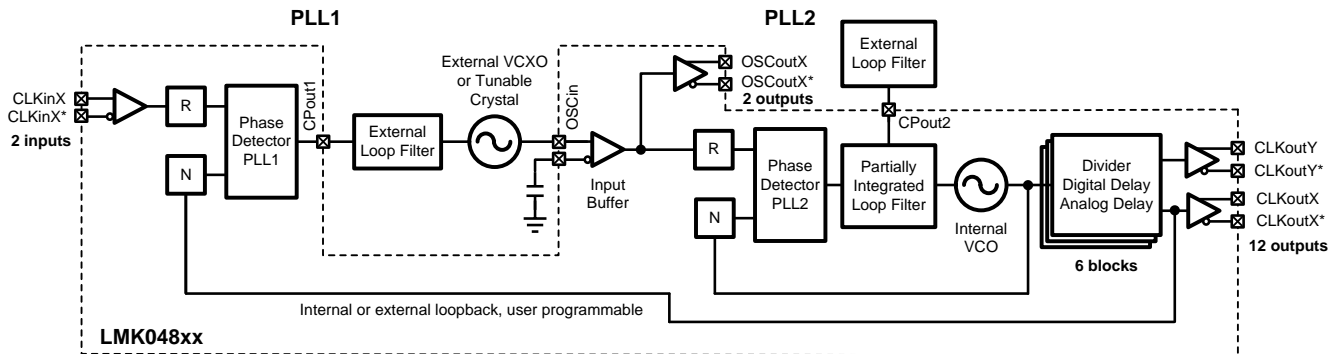


Figure 2-2. Simplified Functional Block Diagram for 0-delay Dual Loop Mode

### 2.1.1.3 Single PLL

Figure 2-3 illustrates the use case of single PLL mode. In single PLL mode only PLL2 is used and PLL1 is powered down. OSCin is used as the reference input. The internal VCO drives up to 6 divide/delay blocks which drive 12 clock outputs. The reference at OSCin can be used to drive up to 2 OSCout ports. OSCin can also optionally drive up to 4 of the clock outputs.

It is also possible to use an external VCO in place of PLL2's internal VCO.

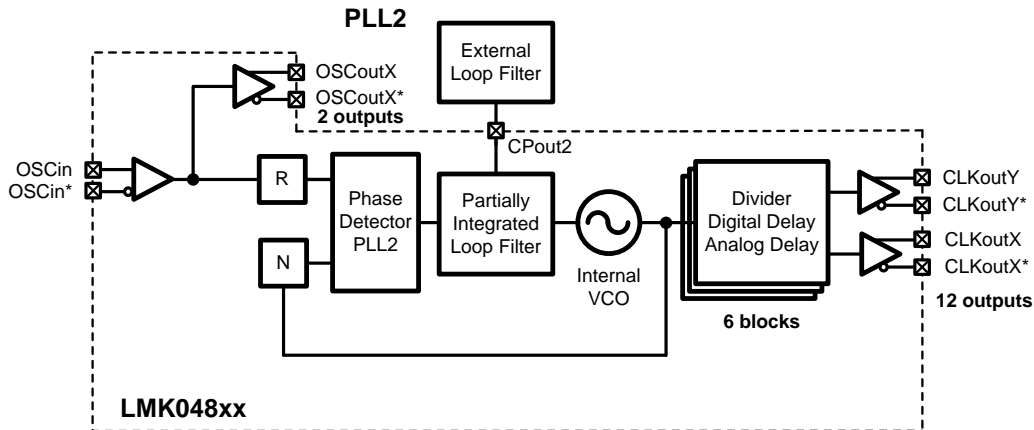


Figure 2-3. Simplified Functional Block Diagram for Single Loop Mode

2.1.1.4 0-delay Single PLL

Figure 2-4 illustrates the use case of 0-delay single PLL mode. This configuration is very similar to Section 2.1.1.3 except that the feedback to PLL2 comes from a clock output. This causes the clock outputs to be in phase with the reference input. Since all the clock outputs can be synchronized together, all the clock outputs can be in phase with the clock input signal. The feedback to PLL2 can be performed internally as shown, or externally using FBCLKin (CLKin1) as an input port.

It is also possible to use an external VCO in place of PLL2's internal VCO.

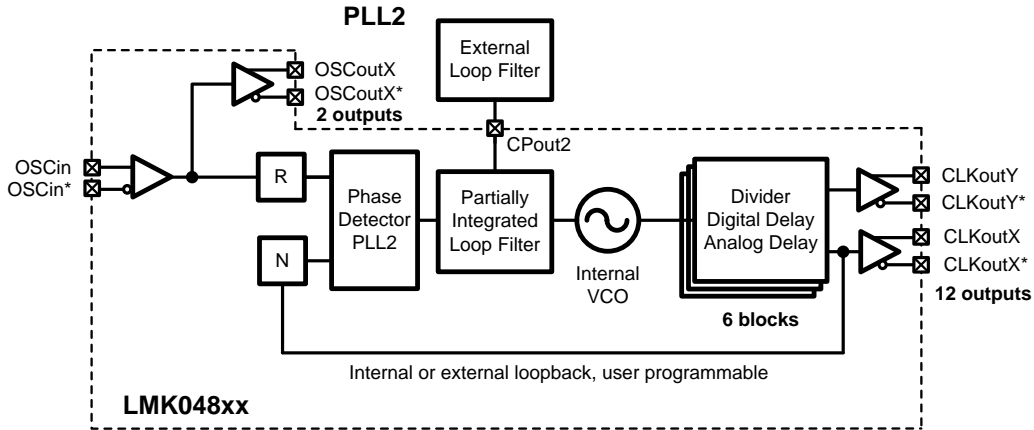


Figure 2-4. Simplified Functional Block Diagram for 0-delay Single Loop Mode

2.1.1.5 Clock Distribution

Figure 2-5 illustrates the LMK04800 used for clock distribution. CLKin1 is used to drive up to 6 divide/delay blocks which drive 12 outputs. OSCin can be used to drive up to 2 OSCout ports. OSCin can also optionally drive up to 4 of the clock outputs.

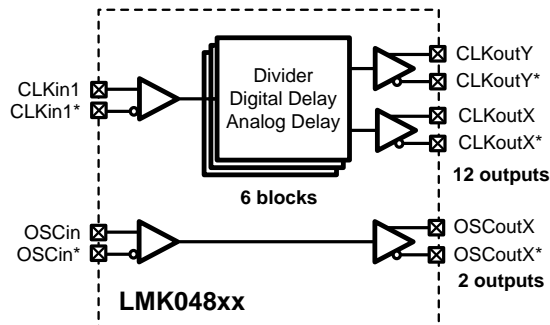


Figure 2-5. Simplified Functional Block Diagram for Mode Clock Distribution

2.1.1.6 Detailed LMK0480x Block Diagram

Figure 2-6 illustrates the complete LMK0480x block diagram for the LMK0480x family.

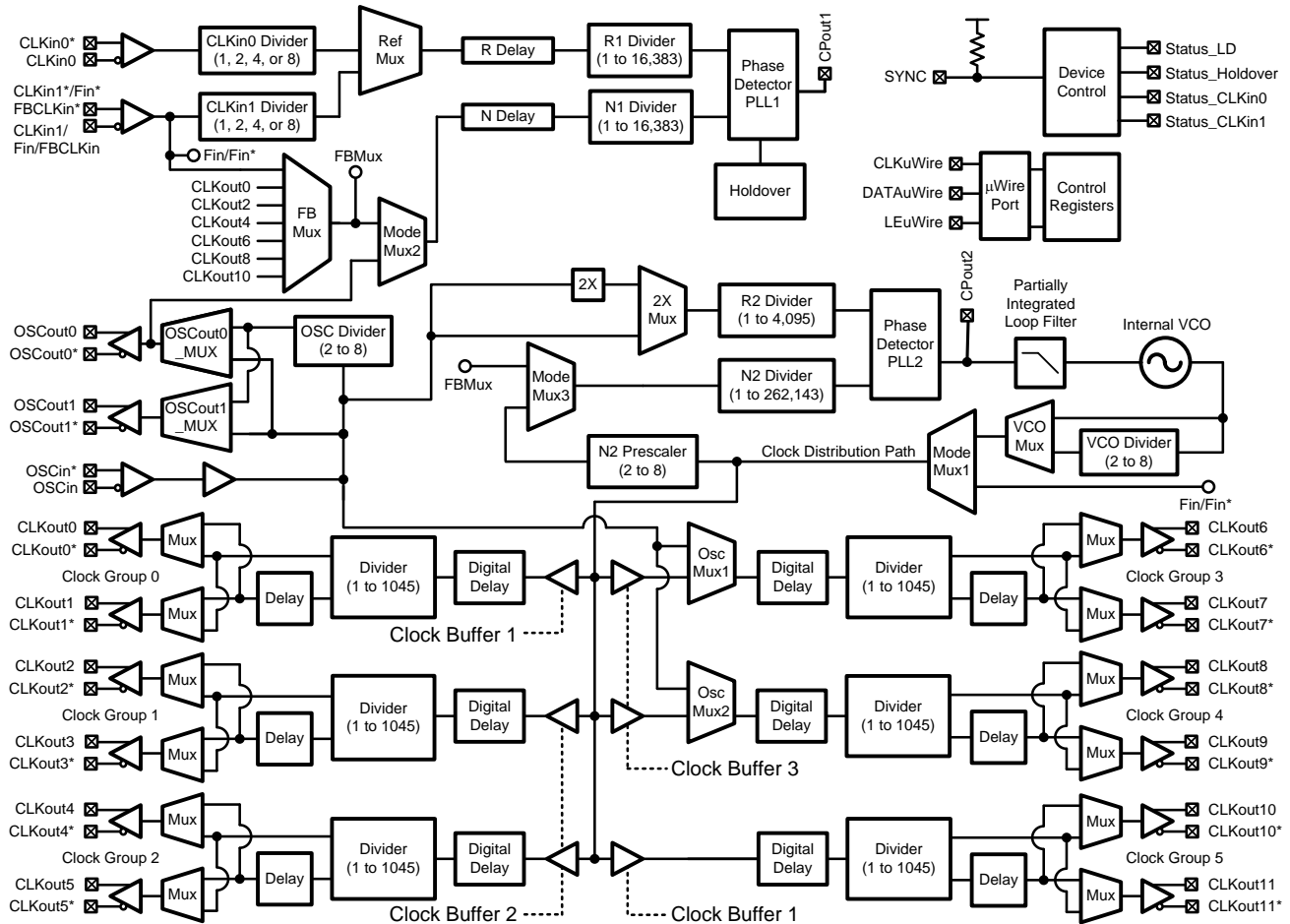


Figure 2-6. Detailed LMK0480x Block Diagram

## 2.1.2 Connection Diagram

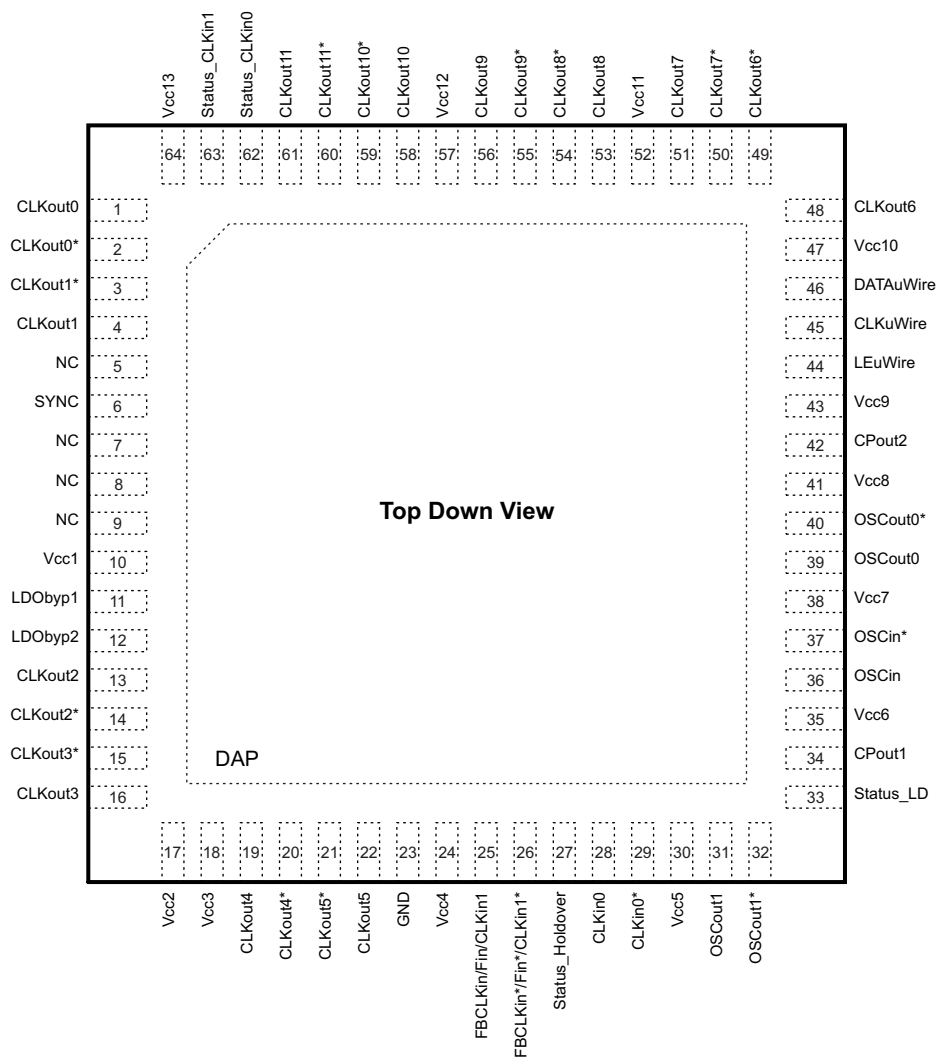


Figure 2-7. 64-Pin WQFN Package

Table 2-1. PIN DESCRIPTIONS<sup>(1)</sup>

| Pin Number | Name(s)           | I/O | Type         | Description  |
|------------|-------------------|-----|--------------|--|
| 1, 2       | CLKout0, CLKout0* | O   | Programmable | Clock output 0 (clock group 0).                          |
| 3, 4       | CLKout1*, CLKout1 | O   | Programmable | Clock output 1 (clock group 0).                          |
| 6          | SYNC              | I/O | Programmable | CLKout Synchronization input or programmable status pin. |
| 5, 7, 8, 9 | NC                |     |              | No Connection. These pins must be left floating.         |
| 10         | Vcc1              |     | PWR          | Power supply for VCO LDO.                                |
| 11         | LDObyp1           |     | ANLG         | LDO Bypass, bypassed to ground with 10 μF capacitor.     |
| 12         | LDObyp2           |     | ANLG         | LDO Bypass, bypassed to ground with a 0.1 μF capacitor.  |
| 13, 14     | CLKout2, CLKout2* | O   | Programmable | Clock output 2 (clock group 1).                          |
| 15, 16     | CLKout3*, CLKout3 | O   | Programmable | Clock output 3 (clock group 1).                          |
| 17         | Vcc2              |     | PWR          | Power supply for clock group 1: CLKout2 and CLKout3.     |
| 18         | Vcc3              |     | PWR          | Power supply for clock group 2: CLKout4 and CLKout5.     |

(1) See Section 9.5.



**Table 2-1. PIN DESCRIPTIONS<sup>(1)</sup> (continued)**

| Pin Number | Name(s)             | I/O | Type         | Description  |
|------------|---------------------|-----|--------------|--|
| 19, 20     | CLKout4, CLKout4*   | O   | Programmable | Clock output 4 (clock group 2).  |
| 21, 22     | CLKout5*, CLKout5   | O   | Programmable | Clock output 5 (clock group 2).  |
| 23         | GND                 |     | PWR          | Ground   |
| 24         | Vcc4                |     | PWR          | Power supply for digital.  |
| 25, 26     | CLKin1, CLKin1*     | I   | ANLG         | Reference Clock Input Port 1 for PLL1. AC or DC Coupled.   |
|            | FBCLKin, FBCLKin*   |     |              | Feedback input for external clock feedback input (0-delay mode). AC or DC Coupled.   |
|            | Fin/Fin*            |     |              | External VCO input (External VCO mode). AC or DC Coupled.  |
| 27         | Status_Holdover     | I/O | Programmable | Programmable status pin, default readback output. Programmable to holdover mode indicator. Other options available by programming.                         |
| 28, 29     | CLKin0, CLKin0*     | I   | ANLG         | Reference Clock Input Port 0 for PLL1. AC or DC Coupled.   |
| 30         | Vcc5                |     | PWR          | Power supply for clock inputs.   |
| 31, 32     | OScout1, OSCout1*   | O   | LVPECL       | Buffered output 1 of OSCin port.   |
| 33         | Status_LD           | I/O | Programmable | Programmable status pin, default lock detect for PLL1 and PLL2. Other options available by programming.  |
| 34         | CPout1              | O   | ANLG         | Charge pump 1 output.  |
| 35         | Vcc6                |     | PWR          | Power supply for PLL1, charge pump 1.  |
| 36, 37     | OSCin, OSCin*       | I   | ANLG         | Feedback to PLL1, Reference input to PLL2. AC Coupled.   |
| 38         | Vcc7                |     | PWR          | Power supply for OSCin port.   |
| 39, 40     | OScout0, OSCout0*   | O   | Programmable | Buffered output 0 of OSCin port.   |
| 41         | Vcc8                |     | PWR          | Power supply for PLL2, charge pump 2.  |
| 42         | CPout2              | O   | ANLG         | Charge pump 2 output.  |
| 43         | Vcc9                |     | PWR          | Power supply for PLL2.   |
| 44         | LEuWire             | I   | CMOS         | MICROWIRE Latch Enable Input.  |
| 45         | CLKuWire            | I   | CMOS         | MICROWIRE Clock Input.   |
| 46         | DATAuWire           | I   | CMOS         | MICROWIRE Data Input.  |
| 47         | Vcc10               |     | PWR          | Power supply for clock group 3: CLKout6 and CLKout7.   |
| 48, 49     | CLKout6, CLKout6*   | O   | Programmable | Clock output 6 (clock group 3).  |
| 50, 51     | CLKout7*, CLKout7   | O   | Programmable | Clock output 7 (clock group 3).  |
| 52         | Vcc11               |     | PWR          | Power supply for clock group 4: CLKout8 and CLKout9.   |
| 53, 54     | CLKout8, CLKout8*   | O   | Programmable | Clock output 8 (clock group 4).  |
| 55, 56     | CLKout9*, CLKout9   | O   | Programmable | Clock output 9 (clock group 4).  |
| 57         | Vcc12               |     | PWR          | Power supply for clock group 5: CLKout10 and CLKout11.   |
| 58, 59     | CLKout10, CLKout10* | O   | Programmable | Clock output 10 (clock group 5).   |
| 60, 61     | CLKout11*, CLKout11 | O   | Programmable | Clock output 11 (clock group 5).   |
| 62         | Status_CLKin0       | I/O | Programmable | Programmable status pin. Default is input for pin control of PLL1 reference clock selection. CLKin0 LOS status and other options available by programming. |
| 63         | Status_CLKin1       | I/O | Programmable | Programmable status pin. Default is input for pin control of PLL1 reference clock selection. CLKin1 LOS status and other options available by programming. |
| 64         | Vcc13               |     | PWR          | Power supply for clock group 0: CLKout0 and CLKout1.   |
| DAP        | DAP                 |     | GND          | DIE ATTACH PAD, connect to GND.  |



These devices have limited built-in ESD protection. The leads should be shorted together or the device placed in conductive foam during storage or handling to prevent electrostatic damage to the MOS gates.

### 3 Electrical Specifications

#### 3.1 Absolute Maximum Ratings<sup>(1)(2)(3)(4)</sup>

| Parameter  | Symbol    | Ratings                    | Units |
|--|-----------|----------------------------|-------|
| Supply Voltage <sup>(5)</sup>  | $V_{CC}$  | -0.3 to 3.6                | V     |
| Input Voltage  | $V_{IN}$  | -0.3 to ( $V_{CC} + 0.3$ ) | V     |
| Storage Temperature Range  | $T_{STG}$ | -65 to 150                 | °C    |
| Lead Temperature (solder 4 seconds)  | $T_L$     | +260                       | °C    |
| Junction Temperature   | $T_J$     | 150                        | °C    |
| Differential Input Current (CLKinX/X*, OSCin/OSCin*, FBCLKin/FBCLKin*, Fin/Fin*) | $I_{IN}$  | ± 5                        | mA    |
| Moisture Sensitivity Level   | MSL       | 3                          |       |

- (1) "Absolute Maximum Ratings" indicate limits beyond which damage to the device may occur. Operating Ratings indicate conditions for which the device is intended to be functional, but do not ensure specific performance limits. For ensured specifications and test conditions, see the Electrical Characteristics. The ensured specifications apply only to the test conditions listed.
- (2) This device is a high performance RF integrated circuit with an ESD rating up to 2 kV Human Body Model, up to 150 V Machine Model, and up to 750 V Charged Device Model and is ESD sensitive. Handling and assembly of this device should only be done at ESD-free workstations.
- (3) Stresses in excess of the absolute maximum ratings can cause permanent or latent damage to the device. These are absolute stress ratings only. Functional operation of the device is only implied at these or any other conditions in excess of those given in the operation sections of the data sheet. Exposure to absolute maximum ratings for extended periods can adversely affect device reliability.
- (4) If Military/Aerospace specified devices are required, please contact the Texas Instruments Sales Office/Distributors for availability and specifications.
- (5) Never to exceed 3.6 V.

#### 3.2 Package Thermal Resistance

64-Lead WQFN

| Parameter   | Symbol        | Ratings | Units |
|---|---------------|---------|-------|
| Thermal resistance from junction to ambient on 4-layer JEDEC PCB <sup>(1)</sup> | $\theta_{JA}$ | 19.5    | ° C/W |
| Thermal resistance from junction to case <sup>(2)</sup>                         | $\theta_{JC}$ | 1.5     | ° C/W |

- (1) Specification assumes 32 thermal vias connect the die attach pad to the embedded copper plane on the 4-layer JEDEC PCB. These vias play a key role in improving the thermal performance of the WQFN. Note that the JEDEC PCB is a standard thermal measurement PCB and does not represent best performance a PCB can achieve. It is recommended that the maximum number of vias be used in the board layout.  $\theta_{JA}$  is unique for each PCB.
- (2) Case is defined as the DAP (die attach pad).

#### 3.3 Recommended Operating Conditions

| Parameter            | Symbol   | Condition        | Min  | Typical | Max  | Unit |
|----------------------|----------|------------------|------|---------|------|------|
| Junction Temperature | $T_J$    |                  |      |         | 125  | °C   |
| Ambient Temperature  | $T_A$    | $V_{CC} = 3.3$ V | -40  | 25      | 85   | °C   |
| Supply Voltage       | $V_{CC}$ |                  | 3.15 | 3.3     | 3.45 | V    |

### 3.4 Electrical Characteristics<sup>(1)</sup>

(3.15 V ≤ V<sub>CC</sub> ≤ 3.45 V, -40 °C ≤ T<sub>A</sub> ≤ 85 °C. Typical values represent most likely parametric norms at V<sub>CC</sub> = 3.3 V, T<sub>A</sub> = 25 °C, at the Recommended Operating Conditions at the time of product characterization and are not specified.)

| Symbol  | Parameter   | Conditions   | Min   | Typ | Max             | Units           |
|---|---|--|-------|-----|-----------------|-----------------|
| <b>Current Consumption</b>                                |   |  |       |     |                 |                 |
| I <sub>CC_PD</sub>  | Power Down Supply Current   | No DC path to ground on OSCout1/1* <sup>(2)</sup>  |       | 1   | 3               | mA              |
| I <sub>CC_CLKS</sub>                                      | Supply Current with all clocks enabled <sup>(3)</sup>               | All clock delays disabled,<br>CLKoutX_Y_DIV = 1045,<br>CLKoutX_TYPE = 1 (LVDS),<br>PLL1 and PLL2 locked. |       | 505 | 590             | mA              |
| <b>CLKin0/0* and CLKin1/1* Input Clock Specifications</b> |   |  |       |     |                 |                 |
| f <sub>CLKin</sub>  | Clock Input Frequency <sup>(4)</sup>                                |  | 0.001 |     | 500             | MHz             |
| SLEW <sub>CLKin</sub>                                     | Clock Input Slew Rate <sup>(5)</sup>                                | 20% to 80%   | 0.15  | 0.5 |                 | V/ns            |
| V <sub>ID</sub> CLKin                                     | Clock Input<br>Differential Input Voltage <sup>(6)</sup> Figure 4-1 | AC coupled<br>CLKinX_BUF_TYPE = 0 (Bipolar)  | 0.25  |     | 1.55            | V               |
| V <sub>SS</sub> CLKin                                     |   |  | 0.5   |     | 3.1             | V <sub>pp</sub> |
| V <sub>ID</sub> CLKin                                     |   | AC coupled<br>CLKinX_BUF_TYPE = 1 (MOS)  | 0.25  |     | 1.55            | V               |
| V <sub>SS</sub> CLKin                                     |   |  | 0.5   |     | 3.1             | V <sub>pp</sub> |
| V <sub>CLKin</sub>  | Clock Input<br>Single-ended Input Voltage <sup>(5)</sup>            | AC coupled to CLKinX; CLKinX* AC<br>coupled to Ground<br>CLKinX_BUF_TYPE = 0 (Bipolar)                   | 0.25  |     | 2.4             | V <sub>pp</sub> |
|   |   | AC coupled to CLKinX; CLKinX* AC<br>coupled to Ground<br>CLKinX_BUF_TYPE = 1 (MOS)                       | 0.25  |     | 2.4             | V <sub>pp</sub> |
| V <sub>CLKin0-offset</sub>                                | DC offset voltage between<br>CLKin0/CLKin0*<br>CLKin0* - CLKin0     | Each pin AC coupled<br>CLKin0_BUF_TYPE = 0 (Bipolar)   |       | 20  |                 | mV              |
| V <sub>CLKin1-offset</sub>                                | DC offset voltage between<br>CLKin1/CLKin1*<br>CLKin1* - CLKin1     |  |       | 0   |                 | mV              |
| V <sub>CLKinX-offset</sub>                                | DC offset voltage between<br>CLKinX/CLKinX*<br>CLKinX* - CLKinX     | Each pin AC coupled<br>CLKinX_BUF_TYPE = 1 (MOS)   |       | 55  |                 | mV              |
| V <sub>CLKin-VIH</sub>                                    | High input voltage  | DC coupled to CLKinX; CLKinX* AC<br>coupled to Ground<br>CLKinX_BUF_TYPE = 1 (MOS)                       | 2.0   |     | V <sub>CC</sub> | V               |
| V <sub>CLKin-VIL</sub>                                    | Low input voltage   |  | 0.0   |     | 0.4             | V               |

- (1) In order to meet the jitter performance listed in the subsequent sections of this data sheet, the minimum recommended slew rate for all input clocks is 0.5 V/ns. This is especially true for single-ended clocks. Phase noise performance will begin to degrade as the clock input slew rate is reduced. However, the device will function at slew rates down to the minimum listed. When compared to single-ended clocks, differential clocks (LVDS, LVPECL) will be less susceptible to degradation in phase noise performance at lower slew rates due to their common mode noise rejection. However, it is also recommended to use the highest possible slew rate for differential clocks to achieve optimal phase noise performance at the device outputs.
- (2) If emitter resistors are placed on the OSCout1/1\* pins, there will be a DC current to ground which will cause powerdown I<sub>cc</sub> to increase.
- (3) Load conditions for output clocks: LVDS: 100 Ω differential. See applications section [Current Consumption/Power Dissipation Calculations](#) for I<sub>cc</sub> for specific part configuration and how to calculate I<sub>cc</sub> for a specific design.
- (4) CLKin0, CLKin1 maximum is specified by characterization, production tested at 200 MHz.
- (5) Specified by characterization.
- (6) See [Section 4.2](#) for definition of V<sub>ID</sub> and V<sub>OD</sub> voltages.

**Electrical Characteristics<sup>(1)</sup> (continued)**

(3.15 V ≤ V<sub>CC</sub> ≤ 3.45 V, -40 °C ≤ T<sub>A</sub> ≤ 85 °C. Typical values represent most likely parametric norms at V<sub>CC</sub> = 3.3 V, T<sub>A</sub> = 25 °C, at the Recommended Operating Conditions at the time of product characterization and are not specified.)

| Symbol  | Parameter  | Conditions  | Min   | Typ    | Max  | Units           |
|---|--|---|-------|--------|------|-----------------|
| <b>FBCLKin/FBCLKin* and Fin/Fin* Input Specifications</b> |  |   |       |        |      |                 |
| f <sub>FBCLKin</sub>                                      | Clock Input Frequency <sup>(1)</sup>   | AC coupled<br>(CLKinX_BUF_TYPE = 0)<br>MODE = 2 or 8; FEEDBACK_MUX = 6          | 0.001 |        | 1000 | MHz             |
| f <sub>Fin</sub>  | Clock Input Frequency <sup>(1)</sup>   | AC coupled<br>(CLKinX_BUF_TYPE = 0)<br>MODE = 3 or 11                           | 0.001 |        | 3100 | MHz             |
| V <sub>FBCLKin/Fin</sub>                                  | Single Ended<br>Clock Input Voltage <sup>(1)</sup>                                     | AC coupled;<br>(CLKinX_BUF_TYPE = 0)  | 0.25  |        | 2.0  | V <sub>pp</sub> |
| SLEW <sub>FBCLKin/Fin</sub>                               | Slew Rate on CLKin <sup>(1)</sup>  | AC coupled; 20% to 80%;<br>(CLKinX_BUF_TYPE = 0)                                | 0.15  | 0.5    |      | V/ns            |
| <b>PLL1 Specifications</b>                                |  |   |       |        |      |                 |
| f <sub>PD1</sub>  | PLL1 Phase Detector Frequency  |   |       |        | 40   | MHz             |
| I <sub>CPout1</sub> SOURCE                                | PLL1 Charge<br>Pump Source Current <sup>(2)</sup>                                      | V <sub>CPout1</sub> = V <sub>CC</sub> /2, PLL1_CP_GAIN = 0                      |       | 100    |      | μA              |
|   |  | V <sub>CPout1</sub> = V <sub>CC</sub> /2, PLL1_CP_GAIN = 1                      |       | 200    |      |                 |
|   |  | V <sub>CPout1</sub> = V <sub>CC</sub> /2, PLL1_CP_GAIN = 2                      |       | 400    |      |                 |
|   |  | V <sub>CPout1</sub> = V <sub>CC</sub> /2, PLL1_CP_GAIN = 3                      |       | 1600   |      |                 |
| I <sub>CPout1</sub> SINK                                  | PLL1 Charge<br>Pump Sink Current <sup>(2)</sup>  | V <sub>CPout1</sub> = V <sub>CC</sub> /2, PLL1_CP_GAIN = 0                      |       | -100   |      | μA              |
|   |  | V <sub>CPout1</sub> = V <sub>CC</sub> /2, PLL1_CP_GAIN = 1                      |       | -200   |      |                 |
|   |  | V <sub>CPout1</sub> = V <sub>CC</sub> /2, PLL1_CP_GAIN = 2                      |       | -400   |      |                 |
|   |  | V <sub>CPout1</sub> = V <sub>CC</sub> /2, PLL1_CP_GAIN = 3                      |       | -1600  |      |                 |
| I <sub>CPout1</sub> %MIS                                  | Charge Pump<br>Sink / Source Mismatch  | V <sub>CPout1</sub> = V <sub>CC</sub> /2, T = 25 °C                             |       | 3      | 10   | %               |
| I <sub>CPout1</sub> V <sub>TUNE</sub>                     | Magnitude of Charge Pump Current<br>Variation vs. Charge Pump Voltage                  | 0.5 V < V <sub>CPout1</sub> < V <sub>CC</sub> - 0.5 V<br>T <sub>A</sub> = 25 °C |       | 4      |      | %               |
| I <sub>CPout1</sub> %TEMP                                 | Charge Pump Current vs.<br>Temperature Variation                                       |   |       | 4      |      | %               |
| I <sub>CPout1</sub> TRI                                   | Charge Pump TRI-STATE Leakage<br>Current   | 0.5 V < V <sub>CPout</sub> < V <sub>CC</sub> - 0.5 V                            |       |        | 5    | nA              |
| PN10kHz   | PLL 1/f Noise at 10 kHz offset. <sup>(3)</sup><br>Normalized to 1 GHz Output Frequency | PLL1_CP_GAIN = 400 μA   |       | -117   |      | dBc/Hz          |
|   |  | PLL1_CP_GAIN = 1600 μA  |       | -118   |      |                 |
| PN1Hz   | Normalized Phase Noise<br>Contribution <sup>(4)</sup>                                  | PLL1_CP_GAIN = 400 μA   |       | -221.5 |      | dBc/Hz          |
|   |  | PLL1_CP_GAIN = 1600 μA  |       | -223   |      |                 |

(1) Specified by characterization.

(2) This parameter is programmable.

(3) A specification in modeling PLL in-band phase noise is the 1/f flicker noise, L<sub>PLL\_flicker</sub>(f), which is dominant close to the carrier. Flicker noise has a 10 dB/decade slope. PN10kHz is normalized to a 10 kHz offset and a 1 GHz carrier frequency. PN10kHz = L<sub>PLL\_flicker</sub>(10 kHz) - 20log(Fout / 1 GHz), where L<sub>PLL\_flicker</sub>(f) is the single side band phase noise of only the flicker noise's contribution to total noise, L(f). To measure L<sub>PLL\_flicker</sub>(f) it is important to be on the 10 dB/decade slope close to the carrier. A high compare frequency and a clean crystal are important to isolating this noise source from the total phase noise, L(f). L<sub>PLL\_flicker</sub>(f) can be masked by the reference oscillator performance if a low power or noisy source is used. The total PLL in-band phase noise performance is the sum of L<sub>PLL\_flicker</sub>(f) and L<sub>PLL\_flat</sub>(f).

(4) A specification modeling PLL in-band phase noise. The normalized phase noise contribution of the PLL, L<sub>PLL\_flat</sub>(f), is defined as: PN1Hz = L<sub>PLL\_flat</sub>(f) - 20log(N) - 10log(f<sub>PDx</sub>). L<sub>PLL\_flat</sub>(f) is the single side band phase noise measured at an offset frequency, f, in a 1 Hz bandwidth and f<sub>PDx</sub> is the phase detector frequency of the synthesizer. L<sub>PLL\_flat</sub>(f) contributes to the total noise, L(f).

**Electrical Characteristics<sup>(1)</sup> (continued)**

(3.15 V ≤ V<sub>CC</sub> ≤ 3.45 V, -40 °C ≤ T<sub>A</sub> ≤ 85 °C. Typical values represent most likely parametric norms at V<sub>CC</sub> = 3.3 V, T<sub>A</sub> = 25 °C, at the Recommended Operating Conditions at the time of product characterization and are not specified.)

| Symbol   | Parameter  | Conditions  | Min  | Typ | Max  | Units           |
|--|--|---|------|-----|------|-----------------|
| <b>PLL2 Reference Input (OSCin) Specifications</b> |  |   |      |     |      |                 |
| f <sub>OSCin</sub>                                 | PLL2 Reference Input <sup>(1)</sup>                            |   |      |     | 500  | MHz             |
| SLEW <sub>OSCin</sub>                              | PLL2 Reference Clock minimum slew rate on OSCin <sup>(2)</sup> | 20% to 80%  | 0.15 | 0.5 |      | V/ns            |
| V <sub>OSCin</sub>                                 | Input Voltage for OSCin or OSCin* <sup>(2)</sup>               | AC coupled; Single-ended (Unused pin AC coupled to GND)                     | 0.2  |     | 2.4  | V <sub>pp</sub> |
| V <sub>IDOSCin</sub>                               | Differential voltage swing <a href="#">Figure 4-1</a>          | AC coupled  | 0.2  |     | 1.55 | V               |
| V <sub>SSOSCin</sub>                               |  |   | 0.4  |     | 3.1  | V <sub>pp</sub> |
| V <sub>OSCin-offset</sub>                          | DC offset voltage between OSCin/OSCin* OSCinX* - OSCinX        | Each pin AC coupled   |      | 20  |      | mV              |
| f <sub>doubler_max</sub>                           | Doubler input frequency <sup>(2)</sup>                         | EN_PLL2_REF_2X = 1; <sup>(3)</sup><br>OSCin Duty Cycle 40% to 60%           |      |     | 155  | MHz             |
| <b>Crystal Oscillator Mode Specifications</b>      |  |   |      |     |      |                 |
| f <sub>XTAL</sub>                                  | Crystal Frequency Range <sup>(2)</sup>                         | R <sub>ESR</sub> < 40 Ω   | 6    |     | 20.5 | MHz             |
| P <sub>XTAL</sub>                                  | Crystal Power Dissipation <sup>(4)</sup>                       | Vectron VXB1 crystal, 20.48 MHz,<br>R <sub>ESR</sub> < 40 Ω<br>XTAL_LVL = 0 |      | 100 |      | μW              |
| C <sub>IN</sub>                                    | Input Capacitance of LMK0480x OSCin port                       | -40 to +85 °C   |      | 6   |      | pF              |

(1) F<sub>OSCin</sub> maximum frequency specified by characterization. Production tested at 200 MHz.

(2) Specified by characterization.

(3) The EN\_PLL2\_REF\_2X bit (Register 13) enables/disables a frequency doubler mode for the PLL2 OSCin path.

(4) See Application Section discussion of [Crystal Power Dissipation](#).

**Electrical Characteristics<sup>(1)</sup> (continued)**

(3.15 V ≤ V<sub>CC</sub> ≤ 3.45 V, -40 °C ≤ T<sub>A</sub> ≤ 85 °C. Typical values represent most likely parametric norms at V<sub>CC</sub> = 3.3 V, T<sub>A</sub> = 25 °C, at the Recommended Operating Conditions at the time of product characterization and are not specified.)

| Symbol  | Parameter   | Conditions   | Min  | Typ      | Max  | Units  |
|---|---|--|------|----------|------|--------|
| <b>PLL2 Phase Detector and Charge Pump Specifications</b> |   |  |      |          |      |        |
| f <sub>PD2</sub>  | Phase Detector Frequency  |  |      |          | 155  | MHz    |
| I <sub>CPout</sub> SOURCE                                 | PLL2 Charge Pump Source Current <sup>(1)</sup>  | V <sub>CPout2</sub> =V <sub>CC</sub> /2, PLL2_CP_GAIN = 0  |      | 100      |      | μA     |
|   |   | V <sub>CPout2</sub> =V <sub>CC</sub> /2, PLL2_CP_GAIN = 1  |      | 400      |      |        |
|   |   | V <sub>CPout2</sub> =V <sub>CC</sub> /2, PLL2_CP_GAIN = 2  |      | 1600     |      |        |
|   |   | V <sub>CPout2</sub> =V <sub>CC</sub> /2, PLL2_CP_GAIN = 3  |      | 3200     |      |        |
| I <sub>CPout</sub> SINK                                   | PLL2 Charge Pump Sink Current <sup>(1)</sup>  | V <sub>CPout2</sub> =V <sub>CC</sub> /2, PLL2_CP_GAIN = 0  |      | -100     |      | μA     |
|   |   | V <sub>CPout2</sub> =V <sub>CC</sub> /2, PLL2_CP_GAIN = 1  |      | -400     |      |        |
|   |   | V <sub>CPout2</sub> =V <sub>CC</sub> /2, PLL2_CP_GAIN = 2  |      | -1600    |      |        |
|   |   | V <sub>CPout2</sub> =V <sub>CC</sub> /2, PLL2_CP_GAIN = 3  |      | -3200    |      |        |
| I <sub>CPout2</sub> %MIS                                  | Charge Pump Sink/Source Mismatch  | V <sub>CPout2</sub> =V <sub>CC</sub> /2, T <sub>A</sub> = 25 °C  |      | 3        | 10   | %      |
| I <sub>CPout2</sub> V <sub>TUNE</sub>                     | Magnitude of Charge Pump Current vs. Charge Pump Voltage Variation  | 0.5 V < V <sub>CPout2</sub> < V <sub>CC</sub> - 0.5 V<br>T <sub>A</sub> = 25 °C                            |      | 4        |      | %      |
| I <sub>CPout2</sub> %TEMP                                 | Charge Pump Current vs. Temperature Variation   |  |      | 4        |      | %      |
| I <sub>CPout2</sub> TRI                                   | Charge Pump Leakage   | 0.5 V < V <sub>CPout2</sub> < V <sub>CC</sub> - 0.5 V  |      |          | 10   | nA     |
| PN10kHz   | PLL 1/f Noise at 10 kHz offset <sup>(2)</sup><br>Normalized to<br>1 GHz Output Frequency  | PLL2_CP_GAIN = 400 μA  |      | -118     |      | dBc/Hz |
|   |   | PLL2_CP_GAIN = 3200 μA   |      | -121     |      |        |
| PN1Hz   | Normalized Phase Noise Contribution <sup>(3)</sup>  | PLL2_CP_GAIN = 400 μA  |      | -222.5   |      | dBc/Hz |
|   |   | PLL2_CP_GAIN = 3200 μA   |      | -227     |      |        |
| <b>Internal VCO Specifications</b>                        |   |  |      |          |      |        |
| f <sub>VCO</sub>  | VCO Tuning Range  | LMK04803   | 1840 |          | 2030 | MHz    |
|   |   | LMK04805   | 2148 |          | 2370 |        |
|   |   | LMK04806   | 2370 |          | 2600 |        |
|   |   | LMK04808   | 2750 |          | 3072 |        |
| K <sub>VCO</sub>  | Fine Tuning Sensitivity<br>(The range displayed in the typical column indicates the lower sensitivity is typical at the lower end of the tuning range, and the higher tuning sensitivity is typical at the higher end of the tuning range). | LMK04808   |      | 20 to 36 |      | MHz/V  |
| ΔT <sub>CL</sub>  | Allowable Temperature Drift for Continuous Lock <sup>(4)</sup> <sup>(5)</sup>   | After programming R30 for lock, no changes to output configuration are permitted to ensure continuous lock |      |          | 125  | °C     |

(1) This parameter is programmable

(2) A specification in modeling PLL in-band phase noise is the 1/f flicker noise, L<sub>PLL\_flicker</sub>(f), which is dominant close to the carrier. Flicker noise has a 10 dB/decade slope. PN10kHz is normalized to a 10 kHz offset and a 1 GHz carrier frequency. PN10kHz = L<sub>PLL\_flicker</sub>(10 kHz) - 20log(Fout / 1 GHz), where L<sub>PLL\_flicker</sub>(f) is the single side band phase noise of only the flicker noise's contribution to total noise, L(f). To measure L<sub>PLL\_flicker</sub>(f) it is important to be on the 10 dB/decade slope close to the carrier. A high compare frequency and a clean crystal are important to isolating this noise source from the total phase noise, L(f). L<sub>PLL\_flicker</sub>(f) can be masked by the reference oscillator performance if a low power or noisy source is used. The total PLL in-band phase noise performance is the sum of L<sub>PLL\_flicker</sub>(f) and L<sub>PLL\_flat</sub>(f).

(3) A specification modeling PLL in-band phase noise. The normalized phase noise contribution of the PLL, L<sub>PLL\_flat</sub>(f), is defined as: PN1Hz=L<sub>PLL\_flat</sub>(f) - 20log(N) - 10log(f<sub>PDx</sub>). L<sub>PLL\_flat</sub>(f) is the single side band phase noise measured at an offset frequency, f, in a 1 Hz bandwidth and f<sub>PDx</sub> is the phase detector frequency of the synthesizer. L<sub>PLL\_flat</sub>(f) contributes to the total noise, L(f).

(4) Maximum Allowable Temperature Drift for Continuous Lock is how far the temperature can drift in either direction from the value it was at the time that the R30 register was last programmed, and still have the part stay in lock. The action of programming the R30 register, even to the same value, activates a frequency calibration routine. This implies the part will work over the entire frequency range, but if the temperature drifts more than the maximum allowable drift for continuous lock, then it will be necessary to reload the R30 register to ensure it stays in lock. Regardless of what temperature the part was initially programmed at, the temperature can never drift outside the frequency range of -40 °C to 85 °C without violating specifications.

(5) Specified by characterization.

**Electrical Characteristics<sup>(1)</sup> (continued)**

(3.15 V ≤ V<sub>CC</sub> ≤ 3.45 V, -40 °C ≤ T<sub>A</sub> ≤ 85 °C. Typical values represent most likely parametric norms at V<sub>CC</sub> = 3.3 V, T<sub>A</sub> = 25 °C, at the Recommended Operating Conditions at the time of product characterization and are not specified.)

| Symbol  | Parameter  | Conditions                            | Min | Typ    | Max | Units  |
|---|--|---------------------------------------|-----|--------|-----|--------|
| <b>CLKout Closed Loop Jitter Specifications using a Commercial Quality VCXO<sup>(6)</sup></b>                           |  |                                       |     |        |     |        |
| L(f) <sub>CLKout</sub>  | LMK04808<br>f <sub>CLKout</sub> = 245.76 MHz<br>SSB Phase Noise<br>Measured at Clock Outputs<br>Value is average for all output types <sup>(7)</sup> | Offset = 1 kHz                        |     | -122.5 |     | dBc/Hz |
|   |  | Offset = 10 kHz                       |     | -132.9 |     |        |
|   |  | Offset = 100 kHz                      |     | -135.2 |     |        |
|   |  | Offset = 800 kHz                      |     | -143.9 |     |        |
|   |  | Offset = 10 MHz; LVDS                 |     | -156.0 |     |        |
|   |  | Offset = 10 MHz; LVPECL 1600 mVpp     |     | -157.5 |     |        |
|   |  | Offset = 10 MHz; LVCMOS               |     | -157.1 |     |        |
| J <sub>CLKout</sub><br>LVDS/LVPECL/<br>LVCMOS   | LMK04803 <sup>(7)</sup><br>f <sub>CLKout</sub> = 245.76 MHz<br>Integrated RMS Jitter   | BW = 12 kHz to 20 MHz                 |     | 112    |     | fs rms |
|   |  | BW = 100 Hz to 20 MHz                 |     | 121    |     |        |
|   | LMK04805 <sup>(7)</sup><br>f <sub>CLKout</sub> = 245.76 MHz<br>Integrated RMS Jitter   | BW = 12 kHz to 20 MHz                 |     | 113    |     |        |
|   |  | BW = 100 Hz to 20 MHz                 |     | 122    |     |        |
|   | LMK04806 <sup>(7)</sup><br>f <sub>CLKout</sub> = 245.76 MHz<br>Integrated RMS Jitter   | BW = 12 kHz to 20 MHz                 |     | 115    |     |        |
|   |  | BW = 100 Hz to 20 MHz                 |     | 123    |     |        |
|   | LMK04808 <sup>(7)</sup><br>f <sub>CLKout</sub> = 245.76 MHz<br>Integrated RMS Jitter   | BW = 12 kHz to 20 MHz                 |     | 111    |     |        |
|   |  | BW = 100 Hz to 20 MHz                 |     | 123    |     |        |
| <b>CLKout Closed Loop Jitter Specifications using the Integrated Low Noise Crystal Oscillator Circuit<sup>(8)</sup></b> |  |                                       |     |        |     |        |
|   | LMK04808<br>f <sub>CLKout</sub> = 245.76 MHz<br>Integrated RMS Jitter  | BW = 12 kHz to 20 MHz<br>XTAL_LVL = 3 |     | 192    |     | fs rms |
|   |  | BW = 100 Hz to 20 MHz<br>XTAL_LVL = 3 |     | 450    |     |        |
| <b>Default Power On Reset Clock Output Frequency</b>  |  |                                       |     |        |     |        |
| f <sub>CLKout-startup</sub>   | Default output clock frequency at device power on <sup>(9)</sup>   | CLKout8, LVDS, LMK04803               | 69  | 77     | 87  | MHz    |
|   |  | CLKout8, LVDS, LMK04805               | 90  | 80     | 99  |        |
|   |  | CLKout8, LVDS, LMK04806               | 90  | 98     | 110 |        |
|   |  | CLKout8, LVDS, LMK04808               | 90  | 110    | 130 |        |

(6) VCXO used is a 122.88 MHz Crystek CVHD-950-122.880.

(7) f<sub>VCO</sub> = 2949.12 MHz, PLL1 parameters: F<sub>PD1</sub> = 1.024 MHz, I<sub>CP1</sub> = 100 µA, loop bandwidth = 10 Hz. A 122.88 MHz Crystek CVHD-950-122.880. PLL2 parameters: PLL2\_R = 1, F<sub>PD2</sub> = 122.88 MHz, I<sub>CP2</sub> = 3200 µA, C1 = 47 pF, C2 = 3.9 nF, R2 = 620 Ω, PLL2\_C3\_LF = 0, PLL2\_R3\_LF = 0, PLL2\_C4\_LF = 0, PLL2\_R4\_LF = 0, CLKoutX\_Y\_DIV = 12, and CLKoutX\_ADLY\_SEL = 0.

(8) Crystal used is a 20.48 MHz Vectron VXB1-1150-20M480 and Skyworks varactor diode, SMV-1249-074LF.

(9) CLKout6 and OSCout0 also oscillate at start-up at the frequency of the VCXO attached to OSCin port.

**Electrical Characteristics<sup>(1)</sup> (continued)**

(3.15 V ≤ V<sub>CC</sub> ≤ 3.45 V, -40 °C ≤ T<sub>A</sub> ≤ 85 °C. Typical values represent most likely parametric norms at V<sub>CC</sub> = 3.3 V, T<sub>A</sub> = 25 °C, at the Recommended Operating Conditions at the time of product characterization and are not specified.)

| Symbol                      | Parameter  | Conditions  | Min | Typ  | Max | Units |
|-----------------------------|--|---|-----|------|-----|-------|
| <b>Clock Skew and Delay</b> |  |   |     |      |     |       |
| T <sub>SKEW</sub>           | Maximum CLKoutX to CLKoutY <sup>(1)</sup> <sup>(2)</sup>   | LVDS-to-LVDS, T = 25 °C,<br>F <sub>CLK</sub> = 800 MHz, R <sub>L</sub> = 100 Ω<br>AC coupled  |     | 30   |     | ps    |
|                             |  | LVPECL-to-LVPECL,<br>T = 25 °C,<br>F <sub>CLK</sub> = 800 MHz, R <sub>L</sub> = 100 Ω<br>emitter resistors =<br>240 Ω to GND<br>AC coupled  |     | 30   |     |       |
|                             | Maximum skew between any two<br>LVCMOS outputs, same CLKout or<br>different CLKout <sup>(1)</sup> <sup>(2)</sup> | R <sub>L</sub> = 50 Ω, C <sub>L</sub> = 5 pF,<br>T = 25 °C, F <sub>CLK</sub> = 100 MHz.   |     | 100  |     |       |
| MixedT <sub>SKEW</sub>      | LVDS or LVPECL to LVCMOS   | Same device, T = 25 °C,<br>250 MHz  |     | 750  |     | ps    |
| td <sub>0-DELAY</sub>       | CLKin to CLKoutX delay <sup>(1)</sup>  | MODE = 2<br>PLL1_R_DLY = 0; PLL1_N_DLY = 0  |     | 1850 |     | ps    |
|                             |  | MODE = 2<br>PLL1_R_DLY = 0; PLL1_N_DLY = 0;<br>VCO Frequency = 2949.12 MHz<br>Analog delay select = 0;<br>Feedback clock digital delay = 11;<br>Feedback clock half step = 1;<br>Output clock digital delay = 5;<br>Output clock half step = 0; |     | 0    |     |       |

- (1) Equal loading and identical clock output configuration on each clock output is required for specification to be valid. Specification not valid for delay mode.
- (2) Specified by characterization.



**Electrical Characteristics<sup>(1)</sup> (continued)**

(3.15 V ≤ V<sub>CC</sub> ≤ 3.45 V, -40 °C ≤ T<sub>A</sub> ≤ 85 °C. Typical values represent most likely parametric norms at V<sub>CC</sub> = 3.3 V, T<sub>A</sub> = 25 °C, at the Recommended Operating Conditions at the time of product characterization and are not specified.)

| Symbol  | Parameter  | Conditions   | Min   | Typ                    | Max   | Units |
|---|--|--|-------|------------------------|-------|-------|
| <b>LVDS Clock Outputs (CLKoutX), CLKoutX_TYPE = 1</b>             |  |  |       |                        |       |       |
| f <sub>CLKout</sub>   | Maximum Frequency <sup>(1)</sup> <sup>(2)</sup>                        | R <sub>L</sub> = 100 Ω   | 1536  |                        |       | MHz   |
| V <sub>OD</sub>   | Differential Output Voltage <a href="#">Figure 4-2</a>                 | T = 25 °C, DC measurement<br>AC coupled to receiver input<br>R = 100 Ω differential termination          | 250   | 400                    | 450   | mV    |
| V <sub>SS</sub>   |  |  | 500   | 800                    | 900   | mVpp  |
| ΔV <sub>OD</sub>  | Change in Magnitude of V <sub>OD</sub> for complementary output states |  | -50   |                        | 50    | mV    |
| V <sub>OS</sub>   | Output Offset Voltage  |  | 1.125 | 1.25                   | 1.375 | V     |
| ΔV <sub>OS</sub>  | Change in V <sub>OS</sub> for complementary output states              |  |       |                        | 35    | mV    |
| T <sub>R</sub> / T <sub>F</sub>                                   | Output Rise Time   | 20% to 80%, R <sub>L</sub> = 100 Ω   |       | 200                    |       | ps    |
|   | Output Fall Time   | 80% to 20%, R <sub>L</sub> = 100 Ω   |       |                        |       |       |
| I <sub>SA</sub><br>I <sub>SB</sub>                                | Output short circuit current single ended                              | Single-ended output shorted to GND<br>T = 25 °C  | -24   |                        | 24    | mA    |
| I <sub>SAB</sub>  | Output short circuit current - differential                            | Complimentary outputs tied together  | -12   |                        | 12    | mA    |
| <b>LVPECL Clock Outputs (CLKoutX)</b>                             |  |  |       |                        |       |       |
| f <sub>CLKout</sub>   | Maximum Frequency <sup>(1)</sup> <sup>(2)</sup>                        |  | 1536  |                        |       | MHz   |
| T <sub>R</sub> / T <sub>F</sub>                                   | 20% to 80% Output Rise   | R <sub>L</sub> = 100 Ω, emitter resistors = 240 Ω to GND<br>CLKoutX_TYPE = 4 or 5<br>(1600 or 2000 mVpp) |       | 150                    |       | ps    |
|   | 80% to 20% Output Fall Time  |  |       |                        |       |       |
| <b>700 mVpp LVPECL Clock Outputs (CLKoutX), CLKoutX_TYPE = 2</b>  |  |  |       |                        |       |       |
| V <sub>OH</sub>   | Output High Voltage  | T = 25 °C, DC measurement<br>Termination = 50 Ω to<br>V <sub>CC</sub> - 1.4 V                            |       | V <sub>CC</sub> - 1.03 |       | V     |
| V <sub>OL</sub>   | Output Low Voltage   |  |       | V <sub>CC</sub> - 1.41 |       | V     |
| V <sub>OD</sub>   | Output Voltage <a href="#">Figure 4-2</a>                              |  | 305   | 380                    | 440   | mV    |
| V <sub>SS</sub>   |  |  | 610   | 760                    | 880   | mVpp  |
| <b>1200 mVpp LVPECL Clock Outputs (CLKoutX), CLKoutX_TYPE = 3</b> |  |  |       |                        |       |       |
| V <sub>OH</sub>   | Output High Voltage  | T = 25 °C, DC measurement<br>Termination = 50 Ω to<br>V <sub>CC</sub> - 1.7 V                            |       | V <sub>CC</sub> - 1.07 |       | V     |
| V <sub>OL</sub>   | Output Low Voltage   |  |       | V <sub>CC</sub> - 1.69 |       | V     |
| V <sub>OD</sub>   | Output Voltage <a href="#">Figure 4-2</a>                              |  | 545   | 625                    | 705   | mV    |
| V <sub>SS</sub>   |  |  | 1090  | 1250                   | 1410  | mVpp  |
| <b>1600 mVpp LVPECL Clock Outputs (CLKoutX), CLKoutX_TYPE = 4</b> |  |  |       |                        |       |       |
| V <sub>OH</sub>   | Output High Voltage  | T = 25 °C, DC Measurement<br>Termination = 50 Ω to<br>V <sub>CC</sub> - 2.0 V                            |       | V <sub>CC</sub> - 1.10 |       | V     |
| V <sub>OL</sub>   | Output Low Voltage   |  |       | V <sub>CC</sub> - 1.97 |       | V     |
| V <sub>OD</sub>   | Output Voltage <a href="#">Figure 4-2</a>                              |  | 660   | 870                    | 965   | mV    |
| V <sub>SS</sub>   |  |  | 1320  | 1740                   | 1930  | mVpp  |

(1) Specified by characterization.

(2) Refer to [Section 5](#) for output operation performance at higher frequencies than the minimum maximum output frequency.

**Electrical Characteristics<sup>(1)</sup> (continued)**

(3.15 V ≤ V<sub>CC</sub> ≤ 3.45 V, -40 °C ≤ T<sub>A</sub> ≤ 85 °C. Typical values represent most likely parametric norms at V<sub>CC</sub> = 3.3 V, T<sub>A</sub> = 25 °C, at the Recommended Operating Conditions at the time of product characterization and are not specified.)

| Symbol   | Parameter   | Conditions  | Min                   | Typ                    | Max             | Units |
|--|---|---|-----------------------|------------------------|-----------------|-------|
| <b>2000 mVpp LVPECL (2VPECL) Clock Outputs (CLKoutX), CLKoutX_TYPE = 5</b> |   |   |                       |                        |                 |       |
| V <sub>OH</sub>  | Output High Voltage   | T = 25 °C, DC Measurement<br>Termination = 50 Ω to<br>V <sub>CC</sub> - 2.3 V     |                       | V <sub>CC</sub> - 1.13 |                 | V     |
| V <sub>OL</sub>  | Output Low Voltage  |   |                       | V <sub>CC</sub> - 2.20 |                 | V     |
| V <sub>OD</sub>  | Output Voltage <a href="#">Figure 4-2</a>                     |   | 800                   | 1070                   | 1200            | mV    |
| V <sub>SS</sub>  |   |   | 1600                  | 2140                   | 2400            | mVpp  |
| <b>LVC MOS Clock Outputs (CLKoutX)</b>                                     |   |   |                       |                        |                 |       |
| f <sub>CLKout</sub>  | Maximum Frequency <sup>(1)</sup> <sup>(2)</sup>               | 5 pF Load   | 250                   |                        |                 | MHz   |
| V <sub>OH</sub>  | Output High Voltage   | 1 mA Load   | V <sub>CC</sub> - 0.1 |                        |                 | V     |
| V <sub>OL</sub>  | Output Low Voltage  | 1 mA Load   |                       |                        | 0.1             | V     |
| I <sub>OH</sub>  | Output High Current (Source)                                  | V <sub>CC</sub> = 3.3 V, V <sub>O</sub> = 1.65 V                                  |                       | 28                     |                 | mA    |
| I <sub>OL</sub>  | Output Low Current (Sink)                                     | V <sub>CC</sub> = 3.3 V, V <sub>O</sub> = 1.65 V                                  |                       | 28                     |                 | mA    |
| DUTY <sub>CLK</sub>  | Output Duty Cycle <sup>(1)</sup>                              | V <sub>CC</sub> /2 to V <sub>CC</sub> /2, F <sub>CLK</sub> = 100 MHz<br>T = 25 °C | 45                    | 50                     | 55              | %     |
| T <sub>R</sub>   | Output Rise Time  | 20% to 80%, R <sub>L</sub> = 50 Ω,<br>C <sub>L</sub> = 5 pF                       |                       | 400                    |                 | ps    |
| T <sub>F</sub>   | Output Fall Time  | 80% to 20%, R <sub>L</sub> = 50 Ω,<br>C <sub>L</sub> = 5 pF                       |                       | 400                    |                 | ps    |
| <b>Digital Outputs (Status_CLKinX, Status_LD, Status_Holdover, SYNC)</b>   |   |   |                       |                        |                 |       |
| V <sub>OH</sub>  | High-Level Output Voltage                                     | I <sub>OH</sub> = -500 μA   | V <sub>CC</sub> - 0.4 |                        |                 | V     |
| V <sub>OL</sub>  | Low-Level Output Voltage                                      | I <sub>OL</sub> = 500 μA  |                       |                        | 0.4             | V     |
| <b>Digital Inputs (Status_CLKinX, SYNC)</b>                                |   |   |                       |                        |                 |       |
| V <sub>IH</sub>  | High-Level Input Voltage                                      |   | 1.6                   |                        | V <sub>CC</sub> | V     |
| V <sub>IL</sub>  | Low-Level Input Voltage                                       |   |                       |                        | 0.4             | V     |
| I <sub>IH</sub>  | High-Level Input Current<br>V <sub>IH</sub> = V <sub>CC</sub> | Status_CLKinX_TYPE = 0<br>(High Impedance)  | -5                    |                        | 5               | μA    |
|  |   | Status_CLKinX_TYPE = 1<br>(Pull-up)   | -5                    |                        | 5               |       |
|  |   | Status_CLKinX_TYPE = 2<br>(Pull-down)   | 10                    |                        | 80              |       |
| I <sub>IL</sub>  | Low-Level Input Current<br>V <sub>IL</sub> = 0 V              | Status_CLKinX_TYPE = 0<br>(High Impedance)  | -5                    |                        | 5               | μA    |
|  |   | Status_CLKinX_TYPE = 1<br>(Pull-up)   | -40                   |                        | -5              |       |
|  |   | Status_CLKinX_TYPE = 2<br>(Pull-down)   | -5                    |                        | 5               |       |
| <b>Digital Inputs (CLKuWire, DATAuWire, LEuWire)</b>                       |   |   |                       |                        |                 |       |
| V <sub>IH</sub>  | High-Level Input Voltage                                      |   | 1.6                   |                        | V <sub>CC</sub> | V     |
| V <sub>IL</sub>  | Low-Level Input Voltage                                       |   |                       |                        | 0.4             | V     |
| I <sub>IH</sub>  | High-Level Input Current                                      | V <sub>IH</sub> = V <sub>CC</sub>   | 5                     |                        | 25              | μA    |
| I <sub>IL</sub>  | Low-Level Input Current                                       | V <sub>IL</sub> = 0   | -5                    |                        | 5               | μA    |

(1) Specified by characterization.

(2) Refer to [Section 5](#) for output operation performance at higher frequencies than the minimum maximum output frequency.

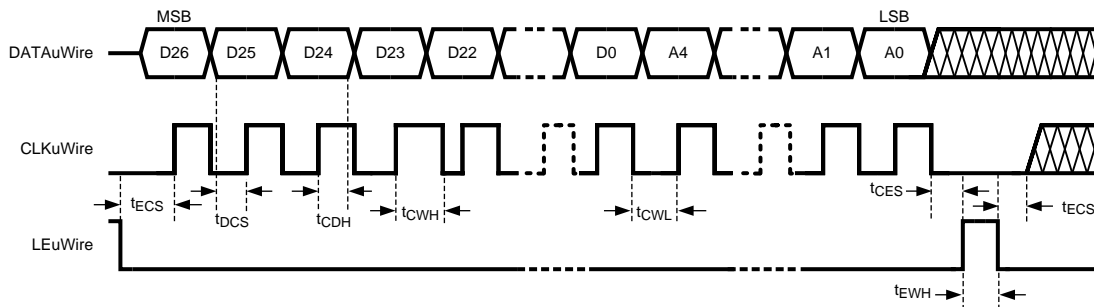
**Electrical Characteristics<sup>(1)</sup> (continued)**

(3.15 V ≤ V<sub>CC</sub> ≤ 3.45 V, -40 °C ≤ T<sub>A</sub> ≤ 85 °C. Typical values represent most likely parametric norms at V<sub>CC</sub> = 3.3 V, T<sub>A</sub> = 25 °C, at the Recommended Operating Conditions at the time of product characterization and are not specified.)

| Symbol                            | Parameter                      | Conditions                    | Min | Typ | Max | Units |
|-----------------------------------|--------------------------------|-------------------------------|-----|-----|-----|-------|
| <b>MICROWIRE Interface Timing</b> |                                |                               |     |     |     |       |
| T <sub>ECS</sub>                  | LE to Clock Set Up Time        | See MICROWIRE Input Timing    | 25  |     |     | ns    |
| T <sub>DCS</sub>                  | Data to Clock Set Up Time      | See MICROWIRE Input Timing    | 25  |     |     | ns    |
| T <sub>CDH</sub>                  | Clock to Data Hold Time        | See MICROWIRE Input Timing    | 8   |     |     | ns    |
| T <sub>CWH</sub>                  | Clock Pulse Width High         | See MICROWIRE Input Timing    | 25  |     |     | ns    |
| T <sub>CWL</sub>                  | Clock Pulse Width Low          | See MICROWIRE Input Timing    | 25  |     |     | ns    |
| T <sub>CES</sub>                  | Clock to LE Set Up Time        | See MICROWIRE Input Timing    | 25  |     |     | ns    |
| T <sub>EWH</sub>                  | LE Pulse Width                 | See MICROWIRE Input Timing    | 25  |     |     | ns    |
| T <sub>CR</sub>                   | Falling Clock to Readback Time | See MICROWIRE Readback Timing | 25  |     |     | ns    |

**3.5 Serial MICROWIRE Timing Diagram**

Register programming information on the DATAuWire pin is clocked into a shift register on each rising edge of the CLKuWire signal. On the rising edge of the LEuWire signal, the register is sent from the shift register to the register addressed. A slew rate of at least 30 V/μs is recommended for these signals. After programming is complete the CLKuWire, DATAuWire, and LEuWire signals should be returned to a low state. If the CLKuWire or DATAuWire lines are toggled while the VCO is in lock, as is sometimes the case when these lines are shared with other parts, the phase noise may be degraded during this programming.

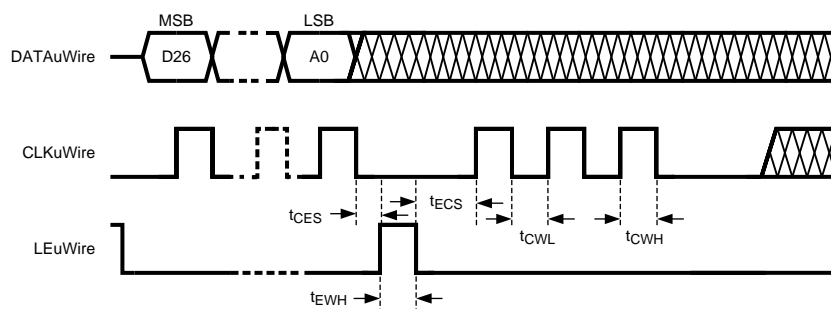


**Figure 3-1. MICROWIRE Timing Diagram**

**3.5.1 ADVANCED MICROWIRE TIMING DIAGRAMS**

**3.5.1.1 3 Extra Clocks or Double Program**

Figure 3-2 shows the timing for the programming sequence for loading CLKoutX\_Y\_DIV > 25 or CLKoutX\_Y\_DDLY > 12 as described in Section 8.1.



**Figure 3-2. MICROWIRE Timing Diagram: Extra CLKuWire Pulses for R0 to R5**

### 3.5.1.2 Three Extra Clocks with LEuWire High

Figure 3-3 shows the timing for the programming sequence which allows SYNC\_EN\_AUTO = 1 when loading CLKoutX\_Y\_DIV > 25 or CLKoutX\_Y\_DDLY > 12. When SYNC\_EN\_AUTO = 1, a SYNC event is automatically generated on the falling edge of LEuWire. See Section 8.1.

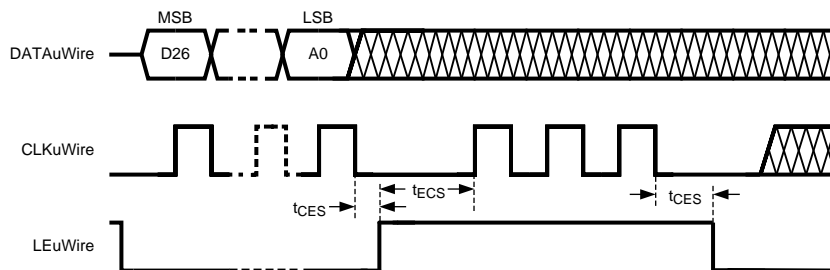


Figure 3-3. MICROWIRE Timing Diagram: Extra CLKuWire Pulses for R0 to R5 with LEuWire Asserted

### 3.5.1.3 Readback

See Section 8.3 for more information on performing a readback operation. Figure 3-4 shows timing for LEuWire for both READBACK\_LE = 1 and 0.

The rising edges of CLKuWire during MICROWIRE readback continue to clock data on DATAuWire into the device during readback. If after the readback, LEuWire transitions from low to high, this data will be latched to the decoded register. The decoded register address consists of the last 5 bits clocked on DATAuWire as shown in the MICROWIRE Timing Diagrams.

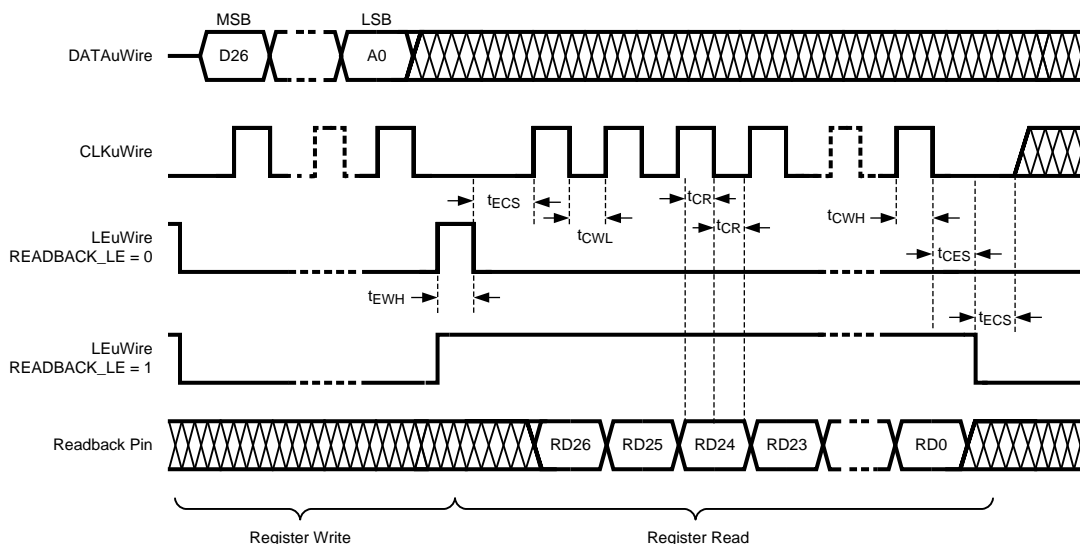
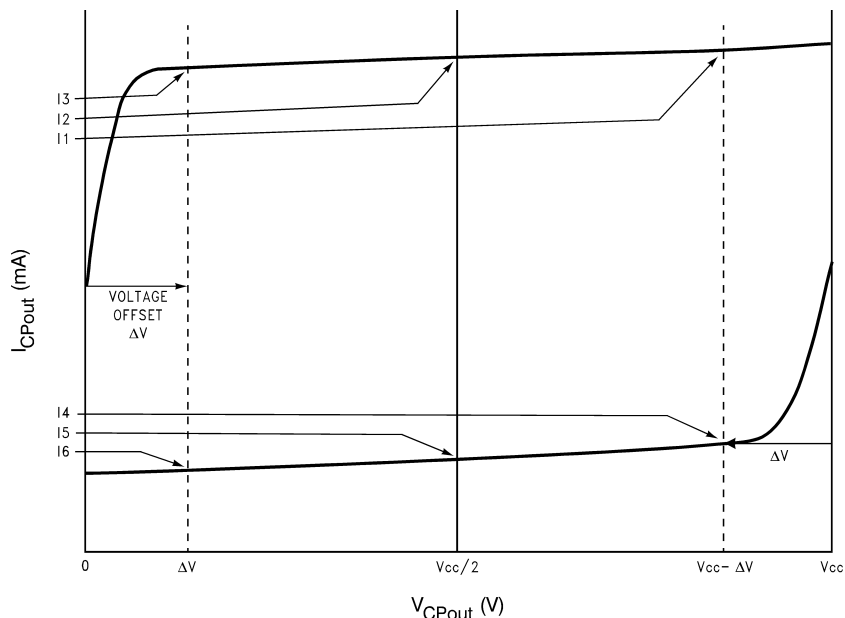


Figure 3-4. MICROWIRE Readback Timing Diagram

## 4 Measurement Definitions

### 4.1 CHARGE PUMP CURRENT SPECIFICATION DEFINITIONS



I1 = Charge Pump Sink Current at  $V_{CPout} = V_{CC} - \Delta V$

I2 = Charge Pump Sink Current at  $V_{CPout} = V_{CC}/2$

I3 = Charge Pump Sink Current at  $V_{CPout} = \Delta V$

I4 = Charge Pump Source Current at  $V_{CPout} = V_{CC} - \Delta V$

I5 = Charge Pump Source Current at  $V_{CPout} = V_{CC}/2$

I6 = Charge Pump Source Current at  $V_{CPout} = \Delta V$

$\Delta V$  = Voltage offset from the positive and negative supply rails. Defined to be 0.5 V for this device.

#### 4.1.1 Charge Pump Output Current Magnitude Variation Vs. Charge Pump Output Voltage

$$I_{CPout} \text{ Vs } V_{CPout} = \frac{|I1| - |I3|}{|I1| + |I3|} \times 100\%$$

$$= \frac{|I4| - |I6|}{|I4| + |I6|} \times 100\%$$

#### 4.1.2 Charge Pump Sink Current Vs. Charge Pump Output Source Current Mismatch

$$I_{CPout} \text{ Sink Vs } I_{CPout} \text{ Source} = \frac{|I2| - |I5|}{|I2| + |I5|} \times 100\%$$

#### 4.1.3 Charge Pump Output Current Magnitude Variation Vs. Temperature

$$I_{CPout} \text{ Vs } T_A = \frac{|I2|_{T_A} - |I2|_{T_A=25^\circ C}}{|I2|_{T_A=25^\circ C}} \times 100\%$$

$$= \frac{|I5|_{T_A} - |I5|_{T_A=25^\circ C}}{|I5|_{T_A=25^\circ C}} \times 100\%$$

## 4.2 DIFFERENTIAL VOLTAGE MEASUREMENT TERMINOLOGY

The differential voltage of a differential signal can be described by two different definitions causing confusion when reading datasheets or communicating with other engineers. This section will address the measurement and description of a differential signal so that the reader will be able to understand and discern between the two different definitions when used.

The first definition used to describe a differential signal is the absolute value of the voltage potential between the inverting and non-inverting signal. The symbol for this first measurement is typically  $V_{ID}$  or  $V_{OD}$  depending on if an input or output voltage is being described.

The second definition used to describe a differential signal is to measure the potential of the non-inverting signal with respect to the inverting signal. The symbol for this second measurement is  $V_{SS}$  and is a calculated parameter. Nowhere in the IC does this signal exist with respect to ground, it only exists in reference to its differential pair.  $V_{SS}$  can be measured directly by oscilloscopes with floating references, otherwise this value can be calculated as twice the value of  $V_{OD}$  as described in the first description.

Figure 4-1 illustrates the two different definitions side-by-side for inputs and Figure 4-2 illustrates the two different definitions side-by-side for outputs. The  $V_{ID}$  and  $V_{OD}$  definitions show  $V_A$  and  $V_B$  DC levels that the non-inverting and inverting signals toggle between with respect to ground.  $V_{SS}$  input and output definitions show that if the inverting signal is considered the voltage potential reference, the non-inverting signal voltage potential is now increasing and decreasing above and below the non-inverting reference. Thus the peak-to-peak voltage of the differential signal can be measured.

$V_{ID}$  and  $V_{OD}$  are often defined as volts (V) and  $V_{SS}$  is often defined as volts peak-to-peak ( $V_{PP}$ ).

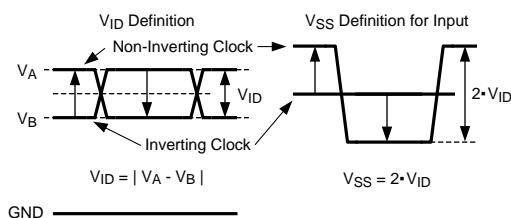


Figure 4-1. Two Different Definitions for Differential Input Signals

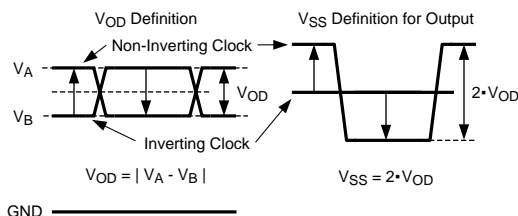


Figure 4-2. Two Different Definitions for Differential Output Signals

Refer to application note [AN-912 Common Data Transmission Parameters and their Definitions \(SNLA036\)](#) for more information.

## 5 Typical Performance Characteristics

### 5.1 CLOCK OUTPUT AC CHARACTERISTICS

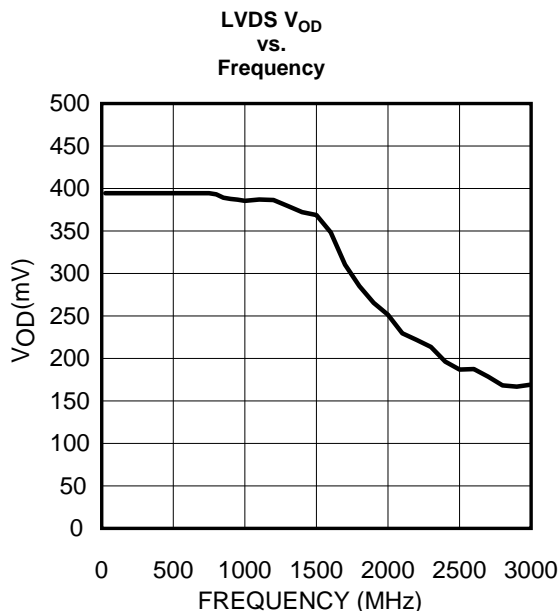


Figure 5-1.

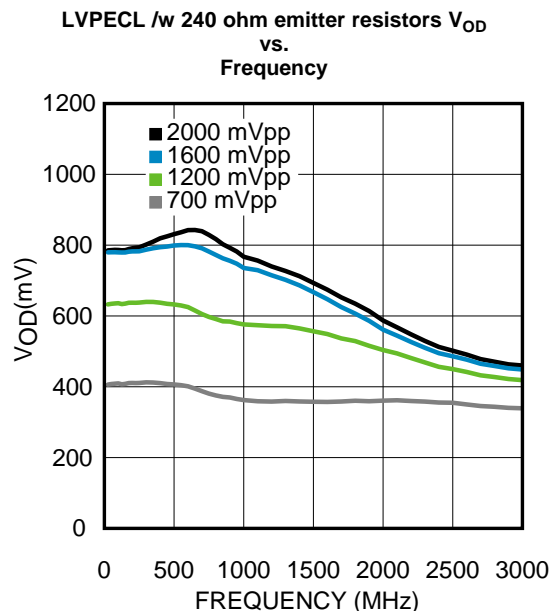


Figure 5-2.

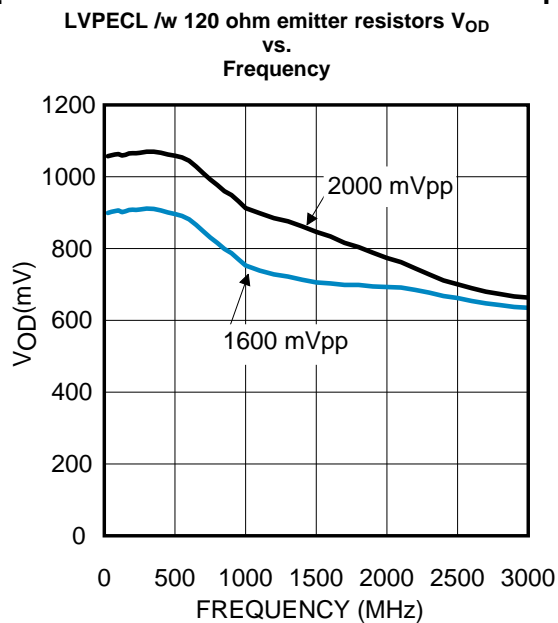


Figure 5-3.

## 6 Features

### 6.1 SYSTEM ARCHITECTURE

The dual loop PLL architecture of the LMK048xx provides the lowest jitter performance over the widest range of output frequencies and phase noise integration bandwidths. The first stage PLL (PLL1) is driven by an external reference clock and uses an external VCXO or tunable crystal to provide a frequency accurate, low phase noise reference clock for the second stage frequency multiplication PLL (PLL2). PLL1 typically uses a narrow loop bandwidth (10 Hz to 200 Hz) to retain the frequency accuracy of the reference clock input signal while at the same time suppressing the higher offset frequency phase noise that the reference clock may have accumulated along its path or from other circuits. This “cleaned” reference clock provides the reference input to PLL2.

The low phase noise reference provided to PLL2 allows PLL2 to operate with a wide loop bandwidth (50 kHz to 200 kHz). The loop bandwidth for PLL2 is chosen to take advantage of the superior high offset frequency phase noise profile of the internal VCO and the good low offset frequency phase noise of the reference VCXO or tunable crystal.

Ultra low jitter is achieved by allowing the external VCXO or Crystal’s phase noise to dominate the final output phase noise at low offset frequencies and the internal VCO’s phase noise to dominate the final output phase noise at high offset frequencies. This results in best overall phase noise and jitter performance.

The LMK048xx allows subsets of the device to be used to increase the flexibility of device. These different modes are selected using [Section 8.9.1](#). For instance:

- Dual Loop Mode - Typical use case of LMK04808. CLKinX used as reference input to PLL1, OSCin port is connected to VCXO or tunable crystal.
- Single Loop Mode - Powers down PLL1. OSCin port is used as reference input.
- Clock Distribution Mode - Allows input of CLKin1 to be distributed to output with division, digital delay, and analog delay.

See [Section 7](#) for more information on these modes.

### 6.2 PLL1 REDUNDANT REFERENCE INPUTS (CLKin0/CLKin0\* and CLKin1/CLKin1\*)

The LMK0480x has two reference clock inputs for PLL1, CLKin0 and CLKin1. Ref Mux selects CLKin0 or CLKin1. Automatic or manual switching occurs between the inputs.

CLKin0 and CLKin1 each have input dividers. The input divider allows different clock input frequencies to be normalized so that the frequency input to the PLL1 R divider remains constant during automatic switching. By programming these dividers such that the frequency presented to the input of the PLL1\_R divider is the same prevents the user from needing to reprogram the PLL1 R divider when the input reference is changed to another CLKin port with a different frequency.

CLKin1 is shared for use as an external 0-delay feedback (FBCLKin), or for use with an external VCO (Fin).

Fast manual switching between reference clocks is possible with a external pins Status\_CLKin0 and Status\_CLKin1.

### 6.3 PLL1 TUNABLE CRYSTAL SUPPORT

The LMK048xx integrates a crystal oscillator on PLL1 for use with an external crystal and varactor diode to perform jitter cleaning.

The LMK048xx must be programmed to enable Crystal mode.



## 6.4 VCXO/CRYSTAL BUFFERED OUTPUTS

The LMK048xx provides 2 dedicated outputs which are a buffered copy of the PLL2 reference input. This reference input is typically a low noise VCXO or Crystal. When using a VCXO, this output can be used to clock external devices such as microcontrollers, FPGAs, CPLDs, etc. before the LMK048xx is programmed.

The OSCout0 buffer output type is programmable to LVDS, LVPECL, or LVCMOS. The OSCout1 buffer is fixed to LVPECL.

The dedicated output buffers OSCout0 and OSCout1 can output frequency lower than the VCXO or Crystal frequency by programming the OSC Divider. The OSC Divider value range is 1 to 8. Each OSCoutX can individually choose to use the OSC Divider output or to bypass the OSC Divider.

Two clock output groups can also be programmed to be driven by OSCin. This allows a total of 4 additional differential outputs to be buffered outputs of OSCin. When programmed in this way, a total of 6 differential outputs can be driven by a buffered copy of OSCin.

VCXO/Crystal buffered outputs cannot be synchronized to the VCO clock distribution outputs. The assertion of SYNC will still cause these outputs to become low. Since these outputs will turn off and on asynchronously with respect to the VCO sourced clock outputs during a SYNC, it is possible for glitches to occur on the buffered clock outputs when SYNC is asserted and unasserted. If the NO\_SYNC\_CLKoutX\_Y bits are set these outputs will not be affected by the SYNC event except that the phase relationship will change with the other synchronized clocks unless a buffered clock output is used as a qualification clock during SYNC.

## 6.5 FREQUENCY HOLDOVER

The LMK048xx supports holdover operation to keep the clock outputs on frequency with minimum drift when the reference is lost until a valid reference clock signal is re-established.

## 6.6 INTEGRATED LOOP FILTER POLES

The LMK048xx features programmable 3rd and 4th order loop filter poles for PLL2. These internal resistors and capacitor values may be selected from a fixed range of values to achieve either a 3rd or 4th order loop filter response. The integrated programmable resistors and capacitors compliment external components mounted near the chip.

These integrated components can be effectively disabled by programming the integrated resistors and capacitors to their minimum values.

## 6.7 INTERNAL VCO

The output of the internal VCO is routed to a mux which allows the user to select either the direct VCO output or a divided version of the VCO for the Clock Distribution Path. This same selection is also fed back to the PLL2 phase detector through a prescaler and N-divider.

The mux selectable VCO divider has a divide range of 2 to 8 with 50% output duty cycle for both even and odd divide values.

The primary use of the VCO divider is to achieve divides greater than the clock output divider supports alone.

## 6.8 EXTERNAL VCO MODE

The Fin/Fin\* input allows an external VCO to be used with PLL2 of the LMK048xx.

Using an external VCO reduces the number of available clock inputs by one.

## 6.9 CLOCK DISTRIBUTION

The LMK048xx features a total of 12 outputs driven from the internal or external VCO.

All VCO driven outputs have programmable output types. They can be programmed to LVPECL, LVDS, or LVCMOS. When all distribution outputs are configured for LVCMOS or single ended LVPECL a total of 24 outputs are available.

If the buffered OSCin outputs OSCout0 and OSCout1 are included in the total number of clock outputs the LMK048xx is able to distribute, then up to 14 differential clocks or up to 28 single ended clocks may be generated with the LMK048xx.

The following sections discuss specific features of the clock distribution channels that allow the user to control various aspects of the output clocks.

### 6.9.1 CLKout DIVIDER

Each clock group, which is a pair of outputs such as CLKout0 and CLKout1, has a single clock output divider. The divider supports a divide range of 1 to 1045 (even and odd) with 50% output duty cycle. When divides of 26 or greater are used, the divider/delay block uses extended mode.

The VCO Divider may be used to reduce the divide needed by the clock group divider so that it may operate in normal mode instead of extended mode. This can result in a small current saving if enabling the VCO Divider allows 3 or more clock output divides to change from extended to normal mode.

### 6.9.2 CLKout DELAY

The [Section 7.9](#) section includes both a fine (analog) and coarse (digital) delay for phase adjustment of the clock outputs.

The fine (analog) delay allows a nominal 25 ps step size and range from 0 to 475 ps of total delay. Enabling the analog delay adds a nominal 500 ps of delay in addition to the programmed value. When adjusting analog delay, glitches may occur on the clock outputs being adjusted. Analog delay may not operate at frequencies above the minimum-ensured maximum output frequency of 1536 MHz.

The coarse (digital) delay allows a group of outputs to be delayed by 4.5 to 12 clock distribution path cycles in normal mode, or from 12.5 to 522 VCO cycles in extended mode. The delay step can be as small as half the period of the clock distribution path by using the CLKoutX\_Y\_HS bit provided the output divide value is greater than 1. for example, 2 GHz VCO frequency without using the VCO divider results in 250 ps coarse tuning steps. The coarse (digital) delay value takes effect on the clock outputs after a SYNC event.

There are 3 different ways to use the digital (coarse) delay.

1. Fixed Digital Delay
2. Absolute Dynamic Digital Delay
3. Relative Dynamic Digital Delay

These are further discussed in the [Section 7](#).

### 6.9.3 PROGRAMMABLE OUTPUT TYPE

For increased flexibility all LMK048xx clock outputs (CLKoutX) and OSCout0 can be programmed to an LVDS, LVPECL, or LVCMOS output type. OSCout1 is fixed as LVPECL.

Any LVPECL output type can be programmed to 700, 1200, 1600, or 2000 mVpp amplitude levels. The 2000 mVpp LVPECL output type is a Texas Instruments proprietary configuration that produces a 2000 mVpp differential swing for compatibility with many data converters and is also known as 2VPECL.

### 6.9.4 CLOCK OUTPUT SYNCHRONIZATION

Using the SYNC input causes all active clock outputs to share a rising edge. See [Section 7.9.2](#) for more information.

The SYNC event also causes the digital delay values to take effect.

### 6.10 0-DELAY

The 0-delay mode synchronizes the input clock phase to the output clock phase. The 0-delay feedback may be performed with an internal feedback loop from any of the clock groups or with an external feedback loop into the FBCLKin port as selected by the FEEDBACK\_MUX.

Without using 0-delay mode there will be  $n$  possible fixed phase relationships from clock input to clock output depending on the clock output divide value.

Using an external 0-delay feedback reduces the number of available clock inputs by one.

### 6.11 DEFAULT STARTUP CLOCKS

Before the LMK048xx is programmed, CLKout8 is enabled and operating at a nominal frequency and CLKout6 and OSCout0 are enabled and operating at the OSCin frequency. These clocks can be used to clock external devices such as microcontrollers, FPGAs, CPLDs, etc. before the LMK048xx is programmed.

For CLKout6 and OSCout0 to work before the LMK048xx is programmed the device must not be using Crystal mode.

### 6.12 STATUS PINS

The LMK048xx provides status pins which can be monitored for feedback or in some cases used for input depending upon device programming. For example:

- The Status\_Holdover pin may indicate if the device is in hold-over mode.
- The Status\_CLKin0 pin may indicate the LOS (loss-of-signal) for CLKin0.
- The Status\_CLKin0 pin may be an input for selecting the active clock input.
- The Status\_LD pin may indicate if the device is locked.

The status pins can be programmed to a variety of other outputs including analog lock detect, PLL divider outputs, combined PLL lock detect signals, PLL1 Vtune railing, readback, etc. Refer to the [MICROWIRE programming section](#) of this datasheet for more information. Default pin programming is captured in [Table 8-4](#).

### 6.13 REGISTER READBACK

Programmed registers may be read back using the MICROWIRE interface. For readback one of the status pins must be programmed for readback mode.

At no time may registers be programmed to values other than the valid states defined in the datasheet.

## 7 Functional Description

### 7.1 FUNCTIONAL OVERVIEW

In default mode of operation, dual PLL mode with internal VCO, the Phase Frequency Detector in PLL1 compares the active CLKinX reference divided by CLKinX\_PreR\_DIV and PLL1 R divider with the external VCXO or crystal attached to the PLL2 OSCin port divided by PLL1 N divider. The external loop filter for PLL1 should be narrow to provide an ultra clean reference clock from the external VCXO or crystal to the OSCin/OSCin\* pins for PLL2.

The Phase Frequency Detector in PLL2 compares the external VCXO or crystal attached to the OSCin port divided by the PLL2 R divider with the output of the internal VCO divided by the PLL2 N divider and N2 pre-scaler and optionally the VCO divider. The bandwidth of the external loop filter for PLL2 should be designed to be wide enough to take advantage of the low in-band phase noise of PLL2 and the low high offset phase noise of the internal VCO. The VCO output is also placed on the distribution path for the [Section 7.9](#) section. The clock distribution consists of 6 groups of dividers and delays which drive 12 outputs. Each clock group allows the user to select a divide value, a digital delay value, and an analog delay. The 6 groups drive programmable output buffers. Two groups allow their input signal to be from the OSCin port directly.

When a 0-delay mode is used, a clock output will be passed through the feedback mux to the PLL1 N Divider for synchronization and 0-delay.

When an external VCO mode is used, the Fin port will be used to input an external VCO signal. PLL2 Phase comparison will now be with this signal divided by the PLL2 N divider and N2 pre-scaler. The VCO divider may not be used. One less clock input is available when using an external VCO mode.

When a single PLL mode is used, PLL1 is powered down. OSCin is used as a reference to PLL2.

## 7.2 MODE SELECTION

The LMK04800 family is capable of operating in several different modes as programmed by [Section 8.9.1](#).

**Table 7-1. Device Mode Selection**

| MODE<br>R11[31:27] | PLL1 | PLL2 | PLL2 VCO | 0-delay | Clock Dist |
|--------------------|------|------|----------|---------|------------|
| 0                  | X    | X    | Internal |         | X          |
| 2                  | X    | X    | Internal | X       | X          |
| 3                  | X    | X    | External |         | X          |
| 5                  | X    | X    | External | X       | X          |
| 6                  |      | X    | Internal |         | X          |
| 8                  |      | X    | Internal | X       | X          |
| 11                 |      | X    | External |         | X          |
| 16                 |      |      |          |         | X          |

In addition to selecting the device's mode of operation above, some modes require additional configuration. Also there are other features including holdover and dynamic digital delay that can also be enabled.

**Table 7-2. Registers to Further Configure Device Mode of Operation**

| Register          | Holdover | 0-Delay        | Dynamic Digital Delay |
|-------------------|----------|----------------|-----------------------|
| HOLDOVER_MODE     | 2        | —              | —                     |
| EN_TRACK          | User     | —              | —                     |
| DAC_CLK_DIV       | User     | —              | —                     |
| EN_MAN_DAC        | User     | —              | —                     |
| DISABLE_DLD1_DET  | User     | —              | —                     |
| EN_VTUNE_RAIL_DET | User     | —              | —                     |
| DAC_HIGH_TRIP     | User     | —              | —                     |
| DAC_LOW_TRIP      | User     | —              | —                     |
| FORCE_HOLDOVER    | 0        | —              | —                     |
| SYNC_EN_AUTO      | —        | —              | User                  |
| SYNC_QUAL         | —        | —              | 1                     |
| EN_SYNC           | —        | —              | 1                     |
| CLKout4_5_PD      | —        | —              | 0                     |
| EN_FEEDBACK_MUX   | —        | 1              | 1                     |
| FEEDBACK_MUX      | —        | Feedback Clock | Qualifying Clock      |
| NO_SYNC_CLKoutX_Y | —        | —              | User                  |

## 7.3 INPUTS / OUTPUTS

### 7.3.1 PLL1 Reference Inputs (CLKin0 and CLKin1)

The reference clock inputs for PLL1 may be selected from either CLKin0 or CLKin1. The user has the capability to manually select one of the inputs or to configure an automatic switching mode of operation. See [Section 7.4](#) for more info.

CLKin0 and CLKin1 have dividers which allow the device to switch between reference inputs of different frequencies automatically without needing to reprogram the PLL1 R divider. The CLKin pre-divider values are 1, 2, 4, and 8.

CLKin1 input can alternatively be used for external feedback in 0-delay mode (FBCLKin) or for an external VCO input port (Fin).

### 7.3.2 PLL2 OSCin / OSCin\* Port

The feedback from the external oscillator being locked with PLL1 drives the OSCin/OSCin\* pins. Internally this signal is routed to the PLL1 N Divider and to the reference input for PLL2.

This input may be driven with either a single-ended or differential signal and must be AC coupled. If operated in single ended mode, the unused input must be connected to GND with a 0.1  $\mu$ F capacitor.

### 7.3.3 CRYSTAL OSCILLATOR

The internal circuitry of the OSCin port also supports the optional implementation of a crystal based oscillator circuit. A crystal, a varactor diode, and a small number of other external components may be used to implement the oscillator. The internal oscillator circuit is enabled by setting the EN\_PLL2\_XTAL bit. See [Section 8.9.9](#).

## 7.4 INPUT CLOCK SWITCHING

Manual, pin select, and automatic are three different kinds clock input switching modes can be set with the CLKin\_SELECT\_MODE register.

Below is information about how the active input clock is selected and what causes a switching event in the various clock input selection modes.

### 7.4.1 Input Clock Switching - Manual Mode

When CLKin\_SELECT\_MODE is 0 or 1 then CLKin0 or CLKin1 respectively is always selected as the active input clock. Manual mode will also override the EN\_CLKinX bits such that the CLKinX buffer will operate even if CLKinX is disabled with EN\_CLKinX = 0.

#### Entering Holdover

If holdover mode is enabled then holdover mode is entered if:

Digital lock detect of PLL1 goes low and DISABLE\_DLD1\_DET = 0.

#### Exiting Holdover

The active clock for automatic exit of holdover mode is the manually selected clock input.

### 7.4.2 Input Clock Switching - Pin Select Mode

When CLKin\_SELECT\_MODE is 3, the pins Status\_CLKin0 and Status\_CLKin1 select which clock input is active.

#### Clock Switch Event: Pins

Changing the state of Status\_CLKin0 or Status\_CLKin1 pins causes an input clock switch event.

#### Clock Switch Event: PLL1 DLD

To prevent PLL1 DLD high to low transition from causing a input clock switch event and causing the device to enter holdover mode, disable the PLL1 DLD detect by setting DISABLE\_DLD1\_DET = 1. This is the preferred behavior for Pin Select Mode.

#### Configuring Pin Select Mode

The Status\_CLKin0\_TYPE must be programmed to an input value for the Status\_CLKin0 pin to function as an input for pin select mode.

The Status\_CLKin1\_TYPE must be programmed to an input value for the Status\_CLKin1 pin to function as an input for pin select mode.

If the Status\_CLKinX\_TYPE is set as output, the input value is considered "0."

The polarity of Status\_CLKin1 and Status\_CLKin0 input pins can be inverted with the CLKin\_SEL\_INV bit.

[Table 7-3](#) defines which input clock is active depending on Status\_CLKin0 and Status\_CLKin1 state.

**Table 7-3. Active Clock Input - Pin Select Mode**

| Status_CLKin1 | Status_CLKin0 | Active Clock |
|---------------|---------------|--------------|
| 0             | 0             | CLKin0       |
| 0             | 1             | CLKin1       |
| 1             | 0             | Reserved     |
| 1             | 1             | Holdover     |

The pin select mode will override the EN\_CLKinX bits such that the CLKinX buffer will operate even if CLKinX is disabled with EN\_CLKinX = 0. To switch as fast as possible, keep the clock input buffers enabled (EN\_CLKinX = 1) that could be switched to.

#### Pin Select Mode and Host

When in the pin select mode, the host can monitor conditions of the clocking system which could cause the host to switch the active clock input. The LMK048xx device can also provide indicators on the Status\_LD and Status\_HOLDOVER like "DAC Rail," "PLL1 DLD", "PLL1 & PLL2 DLD" which the host can use in determining which clock input to use as active clock input.

#### Switch Event without Holdover

When an input clock switch event is triggered and holdover mode is disabled, the active clock input immediately switches to the selected clock. When PLL1 is designed with a narrow loop bandwidth, the switching transient is minimized.

#### Switch Event with Holdover

When an input clock switch event is triggered and holdover mode is enabled, the device will enter holdover mode and remain in holdover until a holdover exit condition is met as described in [Section 7.5](#). Then the device will complete the reference switch to the pin selected clock input.

### 7.4.3 Input Clock Switching - Automatic Mode

When CLKin\_SELECT\_MODE is 4, the active clock is selected in priority order of enabled clock inputs starting upon an input clock switch event. The priority order of the clocks is CLKin0 → CLKin1 → CLKin0, etc.

For a clock input to be eligible to be switched through, it must be enabled using EN\_CLKinX.

#### Starting Active Clock

Upon programming this mode, the currently active clock remains active if PLL1 lock detect is high. To ensure a particular clock input is the active clock when starting this mode, program CLKin\_SELECT\_MODE to the manual mode which selects the desired clock input (CLKin0 or 1). Wait for PLL1 to lock PLL1\_DLD = 1, then select this mode with CLKin\_SELECT\_MODE = 4.

#### Clock Switch Event: PLL1 DLD

A loss of lock as indicated by PLL1's DLD signal (PLL1\_DLD = 0) will cause an input clock switch event if DISABLE\_DLD1\_DET = 0. PLL1 DLD must go high (PLL1\_DLD = 1) in between input clock switching events.

#### Clock Switch Event: PLL1 V<sub>tune</sub> Rail

If Vtune\_RAIL\_DET\_EN is set and the PLL1 Vtune voltage crosses the DAC high or low threshold, holdover mode will be entered. Since PLL1\_DLD = 0 in holdover a clock input switching event will occur.

#### Clock Switch Event with Holdover

If holdover is enabled and an input clock switch event occurs, holdover mode is entered and the active clock is set to the next enabled clock input in priority order. When the new active clock meets the holdover exit conditions, holdover is exited and the active clock will continue to be used as a reference until another PLL1 loss of lock event. PLL1 DLD must go high in between input clock switching events.

#### Clock Switch Event without Holdover

If holdover is not enabled and an input clock switch event occurs, the active clock is set to the next enabled clock in priority order. The LMK048xx will keep this new input clock as the active clock until another input clock switching event. PLL1 DLD must go high in between input clock switching events.

### 7.4.4 Input Clock Switching - Automatic Mode with Pin Select

When CLKin\_SELECT\_MODE is 6, the active clock is selected using the Status\_CLKinX pins upon an input clock switch event according to [Table 7-4](#).

#### Starting Active Clock

Upon programming this mode, the currently active clock remains active if PLL1 lock detect is high. To ensure a particular clock input is the active clock when starting this mode, program CLKin\_SELECT\_MODE to the manual mode which selects the desired clock input (CLKin0 or 1). Wait for PLL1 to lock PLL1\_DLD = 1, then select this mode with CLKin\_SELECT\_MODE = 6.

#### Clock Switch Event: PLL1 DLD

An input clock switch event is generated by a loss of lock as indicated by PLL1's DLD signal (PLL1 DLD = 0).

#### Clock Switch Event: PLL1 V<sub>tune</sub> Rail

If Vtune\_RAIL\_DET\_EN is set and the PLL1 Vtune voltage crosses the DAC threshold, holdover mode will be entered. Since PLL1\_DLD = 0 in holdover, a clock input switching event will occur.

#### Clock Switch Event with Holdover



If holdover is enabled and an input clock switch event occurs, holdover mode is entered and the active clock is set to the clock input defined by the Status\_CLKinX pins. When the new active clock meets the holdover exit conditions, holdover is exited and the active clock will continue to be used as a reference until another input clock switch event. PLL1 DLD must go high in between input clock switching events.

#### Clock Switch Event without Holdover

If holdover is not enabled and an input clock switch event occurs, the active clock is set to the clock input defined by the Status\_CLKinX pins. The LMK048xx will keep this new input clock as the active clock until another input clock switching event. PLL1 DLD must go high in between input clock switching events.

**Table 7-4. Active Clock Input - Auto Pin Mode**

| Status_CLKin1 | Status_CLKin0 | Active Clock |
|---------------|---------------|--------------|
| X             | 1             | CLKin0       |
| 1             | 0             | CLKin1       |
| 0             | 0             | Reserved     |

The polarity of Status\_CLKin1 and Status\_CLKin0 input pins can be inverted with the CLKin\_SEL\_INV bit.

## 7.5 HOLDOVER MODE

Holdover mode causes PLL2 to stay locked on frequency with minimal frequency drift when an input clock reference to PLL1 becomes invalid. While in holdover mode, the PLL1 charge pump is TRI-STATED and a fixed tuning voltage is set on CPout1 to operate PLL1 in open loop.

#### Enable holdover

Program [Section 8.10.5](#) to enable holdover mode. Holdover mode can be manually enabled by programming the FORCE\_HOLDOVER bit.

The holdover mode can be set to operate in 2 different sub-modes.

- Fixed CPout1 (EN\_TRACK = 0 or 1, EN\_MAN\_DAC = 1).
- Tracked CPout1 (EN\_TRACK = 1, EN\_MAN\_DAC = 0).
  - Not valid when EN\_VTUNE\_RAIL\_DET = 1.

Updates to the DAC value for the Tracked CPout1 sub-mode occurs at the rate of the PLL1 phase detector frequency divided by DAC\_CLK\_DIV. These updates occur any time EN\_TRACK = 1.

The DAC update rate should be programmed for <= 100 kHz to ensure DAC holdover accuracy.

When tracking is enabled the current voltage of DAC can be readback, see [Section 8.15.1](#).

#### Entering holdover

The holdover mode is entered as described in [Section 7.4](#). Typically this is because:

- FORCE\_HOLDOVER bit is set.
- PLL1 loses lock according to PLL1\_DLD, and
  - HOLDOVER\_MODE = 2
  - DISABLE\_DLD1\_DET = 0
- CPout1 voltage crosses DAC high or low threshold, and
  - HOLDOVER\_MODE = 2
  - EN\_VTUNE\_RAIL\_DET = 1
  - EN\_TRACK = 1
  - DAC\_HIGH\_TRIP = User Value
  - DAC\_LOW\_TRIP = User Value
  - EN\_MAN\_DAC = 1
  - MAN\_DAC = User Value

### During holdover

PLL1 is run in open loop mode.

- PLL1 charge pump is set to TRI-STATE.
- PLL1 DLD will be unasserted.
- The HOLDOVER status is asserted
- During holdover If PLL2 was locked prior to entry of holdover mode, PLL2 DLD will continue to be asserted.
- CPout1 voltage will be set to:
  - a voltage set in the MAN\_DAC register (fixed CPout1).
  - a voltage determined to be the last valid CPout1 voltage (tracked CPout1).
- PLL1 DLD will attempt to lock with the active clock input.

The HOLDOVER status signal can be monitored on the Status\_HOLDOVER or Status\_LD pin by programming the HOLDOVER\_MUX or LD\_MUX register to "Holdover Status."

### Exiting holdover

Holdover mode can be exited in one of two ways.

- Manually, by programming the device from the host.
- Automatically, By a clock operating within a specified ppm of the current PLL1 frequency on the active clock input. See [Section 7.4](#) for more detail on which clock input is active.

To exit holdover by programming, set HOLDOVER\_MODE = Disabled. HOLDOVER\_MODE can then be re-enabled by programming HOLDOVER\_MODE = Enabled. Care should be taken to ensure that the active clock upon exiting holdover is as expected, otherwise the CLKIn\_SELECT\_MODE register may need to be re-programmed.

## 7.5.1 Holdover Frequency Accuracy and DAC Performance

When in holdover mode PLL1 will run in open loop and the DAC will set the CPout1 voltage. If Fixed CPout1 mode is used, then the output of the DAC will be a voltage dependant upon the MAN\_DAC register. If Tracked CPout1 mode is used, then the output of the DAC will be the voltage at the CPout1 pin before holdover mode was entered. When using Tracked mode and EN\_MAN\_DAC = 1, during holdover the DAC value is loaded with the programmed value in MAN\_DAC, not the tracked value.

When in Tracked CPout1 mode the DAC has a worst case tracking error of  $\pm 2$  LSBs once PLL1 tuning voltage is acquired. The step size is approximately 3.2 mV, therefore the VCXO frequency error during holdover mode caused by the DAC tracking accuracy is  $\pm 6.4 \text{ mV} \times K_v$ . Where  $K_v$  is the tuning sensitivity of the VCXO in use. Therefore the accuracy of the system when in holdover mode in ppm is:

$$\text{Holdover accuracy (ppm)} = \frac{\pm 6.4 \text{ mV} \times K_v \times 1e6}{\text{VCXO Frequency}}$$

Example: consider a system with a 19.2 MHz clock input, a 153.6 MHz VCXO with a  $K_v$  of 17 kHz/V. The accuracy of the system in holdover in ppm is:

$$\pm 0.71 \text{ ppm} = \pm 6.4 \text{ mV} \times 17 \text{ kHz/V} \times 1e6 / 153.6 \text{ MHz}$$

It is important to account for this frequency error when determining the allowable frequency error window to cause holdover mode to exit.

### 7.5.2 Holdover Mode - Automatic Exit of Holdover

The LMK048xx device can be programmed to automatically exit holdover mode when the accuracy of the frequency on the active clock input achieves a specified accuracy. The programmable variables include PLL1\_WND\_SIZE and DLD\_HOLD\_CNT.

See [Section 9.6](#) to calculate the register values to cause holdover to automatically exit upon reference signal recovery to within a user specified ppm error of the holdover frequency.

It is possible for the time to exit holdover to vary because the condition for automatic holdover exit is for the reference and feedback signals to have a time/phase error less than a programmable value. Because it is possible for two clock signals to be very close in frequency but not close in phase, it may take a long time for the phases of the clocks to align themselves within the allowable time/phase error before holdover exits.

## 7.6 PLLs

### 7.6.1 PLL1

PLL1's maximum phase detector frequency ( $f_{PD1}$ ) is 40 MHz. Since a narrow loop bandwidth should be used for PLL1, the need to operate at high phase detector rate to lower the in-band phase noise becomes unnecessary. The maximum values for the PLL1 R and N dividers is 16,383. Charge pump current ranges from 100 to 1600  $\mu$ A. PLL1 N divider may be driven by OSCin port at the OSCout0\_MUX output (default) or by internal or external feedback as selected by Feedback Mux in 0-delay mode.

Low charge pump currents and phase detector frequencies aid design of low loop bandwidth loop filters with reasonably sized components to allow the VCXO or PLL2 to dominate phase noise inside of PLL2 loop bandwidth. High charge pump currents may be used by PLL1 when using VCXOs with leaky tuning voltage inputs to improve system performance.

### 7.6.2 PLL2

PLL2's maximum phase detector frequency ( $f_{PD2}$ ) is 155 MHz. Operating at highest possible phase detector rate will ensure low in-band phase noise for PLL2 which in turn produces lower total jitter. The in-band phase noise from the reference input and PLL is proportional to  $N^2$ . The maximum value for the PLL2 R divider is 4,095. The maximum value for the PLL2 N divider is 262,143. The N2 Prescaler in the total N feedback path can be programmed for values 2 to 8 (all divides even and odd). Charge pump current ranges from 100 to 3200  $\mu$ A.

High charge pump currents help to widen the PLL2 loop bandwidth to optimize PLL2 performance.

#### 7.6.2.1 PLL2 FREQUENCY DOUBLER

The PLL2 reference input at the OSCin port may be routed through a frequency doubler before the PLL2 R Divider. The frequency doubler feature allows the phase comparison frequency to be increased when a relatively low frequency oscillator is driving the OSCin port. By doubling the PLL2 phase detector frequency, the in-band PLL2 noise is reduced by about 3 dB.

When using the doubler take care to use the PLL2 R Divider to reduce the phase detector frequency to the limit of the PLL2 maximum phase detector frequency.

### 7.6.3 DIGITAL LOCK DETECT

Both PLL1 and PLL2 support digital lock detect. Digital lock detect compares the phase between the reference path (R) and the feedback path (N) of the PLL. When the time error, which is phase error, between the two signals is less than a specified window size ( $\epsilon$ ) a lock detect count increments. When the lock detect count reaches a user specified value lock detect is asserted true. Once digital lock detect is true, a single phase comparison outside the specified window will cause digital lock detect to be asserted false. This is illustrated in [Figure 7-1](#).

The incremental lock detect count feature functions as a digital filter to ensure that lock detect isn't asserted for only a brief time when the phases of R and N are within the specified tolerance for only a brief time during initial phase lock.

The digital lock detect signal can be monitored on the Status\_LD or Status\_Holdover pin. The pin may be programmed to output the status of lock detect for PLL1, PLL2, or both PLL1 and PLL2.

See [Section 9.6](#) for more detailed information on programming the registers to achieve a specified frequency accuracy in ppm with lock detect.

The digital lock detect feature can also be used with holdover to automatically exit holdover mode. See [Section 7.5](#) for more info.

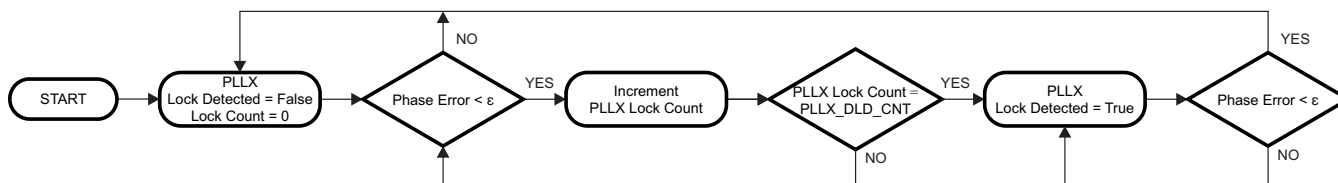


Figure 7-1. Digital Lock Detect Flowchart

## 7.7 STATUS PINS

The Status\_LD, Status\_HOLDOVER, Status\_CLKin0, Status\_CLKin1, and SYNC pins can be programmed to output a variety of signals for indicating various statuses like digital lock detect, holdover, several DAC indicators, and several PLL divider outputs.

### 7.7.1 Logic Low

This is a very simple output. In combination with the output\_MUX register, this output can be toggled between high and low. Useful to confirm MICROWIRE programming or as a general purpose IO.

### 7.7.2 Digital Lock Detect

PLL1 DLD, PLL2 DLD, and PLL1 + PLL2 are selectable on certain output pins. See [Section 7.6.3](#) for more information.

### 7.7.3 Holdover Status

Indicates if the device is in Holdover mode. See [Section 7.5](#) for more information.

### 7.7.4 DAC

Various flags for the DAC can be monitored including DAC Locked, DAC Rail, DAC Low, and DAC High.

When the PLL1 tuning voltage crosses the low threshold, DAC Low is asserted. When PLL1 tuning voltage crosses the high threshold, DAC High is asserted. When either DAC Low or DAC High is asserted, DAC Rail will also be asserted.

DAC Locked is asserted when EN\_Track = 1 and DAC is closely tracking the PLL1 tuning voltage.

### 7.7.5 PLL Divider Outputs

The PLL divider outputs are useful for debugging failure to lock issues. It allows the user to measure the frequency the PLL inputs are receiving. The settings of PLL1\_R, PLL1\_N, PLL2\_R, and PLL2\_N output pulses at the phase detector rate. The settings of PLL1\_R / 2, PLL1\_N / 2, PLL2\_R / 2, and PLL2\_N / 2 output a 50% duty cycle waveform at half the phase detector rate.

### 7.7.6 CLKinX\_LOS

The clock input loss of signal indicator is asserted when LOS is enabled ([Section 8.12.2](#)) and the clock no longer detects an input as defined by the time-out threshold, [Section 8.12.1](#).

### 7.7.7 CLKinX Selected

If this clock is the currently selected/active clock, this pin will be asserted.

### 7.7.8 MICROWIRE Readback

The readback data can be output on any pin programmable to readback mode. For more information on readback see [Section 8.3](#).

## 7.8 VCO

The integrated VCO uses a frequency calibration routine when register R30 is programmed to lock VCO to target frequency. Register R30 contains the PLL2\_N register.

During the frequency calibration the PLL2\_N\_CAL value is used instead of PLL2\_N, this allows 0-delay modes to have a separate PLL2 N value for VCO frequency calibration and regular operation. See [Section 8.21](#), [Section 8.22](#) for more information.

## 7.9 CLOCK DISTRIBUTION

### 7.9.1 Fixed Digital Delay

This section discussing Fixed Digital delay and associated registers is fundamental to understanding digital delay and dynamic digital delay.

Clock outputs may be delayed or advanced from one another by up to 517.5 clock distribution path periods. By programming a digital delay value from 4.5 to 522 clock distribution path periods, a relative clock output delay from 0 to 517.5 periods is achieved. The CLKoutX\_Y\_DDLY (5 to 522) and CLKoutX\_Y\_HS (-0.5 or 0) registers set the digital delay as shown in [Table 7-5](#).

**Table 7-5. Possible Digital Delay Values**

| CLKoutX_Y_DDLY | CLKoutX_Y_HS | Digital Delay |
|----------------|--------------|---------------|
| 5              | 1            | 4.5           |
| 5              | 0            | 5             |
| 6              | 1            | 5.5           |
| 6              | 0            | 6             |
| 7              | 1            | 6.5           |
| 7              | 0            | 7             |
| ...            | ...          | ...           |
| 520            | 0            | 520           |
| 521            | 1            | 520.5         |
| 521            | 0            | 521           |
| 522            | 1            | 521.5         |
| 522            | 0            | 522           |

**Note:** Digital delay values only take effect during a SYNC event and if the NO\_SYNC\_CLKoutX\_Y bit is cleared for this clock group. See [Section 7.9.2](#) for more information.

The resolution of digital delay is determined by the frequency of the clock distribution path. The clock distribution path is the output of Mode Mux1 ([Figure 2-6](#)). The best resolution of digital delay is achieved by bypassing the VCO divider.

$$\text{Digital Delay Resolution (with VCO Divider)} = \frac{\text{VCO\_DIV}}{2 \times \text{VCO Frequency}} \quad (1)$$

$$\text{Digital Delay Resolution (VCO Divider bypassed or external VCO)} = \frac{1}{2 \times \text{VCO Frequency}} \quad (2)$$

The digital delay between clock outputs can be dynamically adjusted with no or minimum disruption of the output clocks. See [Section 7.9.2.1](#) for more information.

#### 7.9.1.1 FIXED DIGITAL DELAY - EXAMPLE

Given a VCO frequency of 2949.12 MHz and no VCO divider, by using digital delay the outputs can be adjusted in  $1 / (2 * 2949.12 \text{ MHz}) = \sim 169.54 \text{ ps}$  steps.

To achieve quadrature (90 degree shift) between the 122.88 MHz outputs on CLKout4 and CLKout6 from a VCO frequency of 2949.12 MHz and bypassing the VCO divider, consider the following:

1. The frequency of 122.88 MHz has a period of  $\sim 8.14 \text{ ns}$ .
2. To delay 90 degrees of a 122.88 MHz clock period requires a  $\sim 2.03 \text{ ns}$  delay.
3. Given a digital delay step of  $\sim 169.54 \text{ ps}$ , this requires a digital delay value of 12 steps ( $2.03 \text{ ns} / 169.54 \text{ ps} = 12$ ).
4. Since the 12 steps are half period steps, CLKout6\_7\_DDLY is programmed 6 full periods beyond 5 for a total of 11.

This result in the following programming:

- Clock output dividers to 24. CLKout4\_5\_DIV = 24 and CLKout6\_7\_DIV = 24.
- Set first clock digital delay value. CLKout4\_5\_DDLY = 5, CLKout4\_5\_HS = 0.
- Set second 90 degree shifted clock digital delay value. CLKout6\_7\_DDLY = 11, CLKout6\_7\_HS = 0.

Table 7-6 shows some of the possible phase delays in degrees achievable in the above example.

**Table 7-6. Relative phase shift from CLKout4 & 5 to CLKout6 & 7<sup>(1)</sup>**

| CLKout6_7_DDLY | CLKout6_7_HS | Relative Digital Delay | Degrees of 122.88 MHz |
|----------------|--------------|------------------------|-----------------------|
| 5              | 1            | -0.5                   | -7.5°                 |
| 5              | 0            | 0.0                    | 0°                    |
| 6              | 1            | 0.5                    | 7.5°                  |
| 6              | 0            | 1.0                    | 15.0°                 |
| 7              | 1            | 1.5                    | 22.5°                 |
| 7              | 0            | 2.0                    | 30.0°                 |
| 8              | 1            | 2.5                    | 37.5°                 |
| 8              | 0            | 3.0                    | 45.0°                 |
| 9              | 1            | 3.5                    | 52.5°                 |
| 9              | 0            | 4.0                    | 60.0°                 |
| 10             | 1            | 4.5                    | 67.5°                 |
| 10             | 0            | 5.0                    | 75.0°                 |
| 11             | 1            | 5.5                    | 82.5°                 |
| 11             | 0            | 6.0                    | 90.0°                 |
| 12             | 1            | 6.5                    | 97.5°                 |
| 12             | 0            | 7.0                    | 105.0°                |
| 13             | 1            | 7.5                    | 112.5°                |
| 13             | 0            | 8.0                    | 120.0°                |
| 14             | 1            | 8.5                    | 127.5°                |
| ...            | ...          | ...                    | ...                   |

(1) CLKout4\_5\_DDLY = 5 and CLKout4\_5\_HS = 0

Figure 7-3 illustrates clock outputs programmed with different digital delay values during a SYNC event.

Refer to Section 7.9.2.1 for more information on dynamically adjusting digital delay.

## 7.9.2 Clock Output Synchronization (SYNC)

The purpose of the SYNC function is to synchronize the clock outputs with a fixed and known phase relationship between each clock output selected for SYNC. SYNC can also be used to hold the outputs in a low or 0 state. The NO\_SYNC\_CLKoutX\_Y bits can be set to disable synchronization for a clock group.

To enable SYNC, EN\_SYNC must be set. See Section 8.9.2.

The digital delay value set by CLKoutX\_Y\_DDLY takes effect only upon a SYNC event. The digital delay due to CLKoutX\_Y\_HS takes effect immediately upon programming. See Section 7.9.2.1 for more information on dynamically changing digital delay.

During a SYNC event, clock outputs driven by the VCO are not synchronized to clock outputs driven by OSCin. OSCout0 and OSCout1 are always driven by OSCin. CLKout6, 7, 8, or 9 may be driven by OSCin depending on the CLKoutX\_Y\_OSCin\_Sel bit value. While SYNC is asserted, NO\_SYNC\_CLKoutX\_Y operates normally for CLKout6, 7, 8, and 9 under all circumstances. SYNC operates normally for CLKout6, 7, 8, and 9 when driven by VCO.

### Effect of SYNC

When SYNC is asserted, the outputs to be synchronized are held in a logic low state. When SYNC is unasserted, the clock outputs to be synchronized are activated and will transition to a high state simultaneously with one another except where different digital delay values have been programmed.

Refer to [Section 7.9.2.1](#) for SYNC functionality when SYNC\_QUAL = 1.

**Table 7-7. Steady State Clock Output Condition Given Specified Inputs**

| SYNC_TYPE           | SYNC_POL_INV | SYNC Pin | Clock Output State |
|---------------------|--------------|----------|--------------------|
| 0,1,2 (Input)       | 0            | 0        | Active             |
| 0,1,2 (Input)       | 0            | 1        | Low                |
| 0,1,2 (Input)       | 1            | 0        | Low                |
| 0,1,2 (Input)       | 1            | 1        | Active             |
| 3, 4, 5, 6 (Output) | 0            | 0 or 1   | Active             |
| 3, 4, 5, 6 (Output) | 1            | 0 or 1   | Low                |

### Methods of Generating SYNC

There are five methods to generate a SYNC event:

- Manual:
  - Asserting the SYNC pin according to the polarity set by SYNC\_POL\_INV.
  - Toggling the SYNC\_POL\_INV bit through MICROWIRE will cause a SYNC to be asserted.
- Automatic:
  - If PLL1\_SYNC\_DLD or PLL2\_SYNC\_DLD is set, the SYNC pin will be asserted while DLD (digital lock detect) is false for PLL1 or PLL2 respectively.
  - Programming Register R30, which contains PLL2\_N will generate a SYNC event when using the internal VCO.
  - Programming Register R0 through R5 when SYNC\_EN\_AUTO = 1.

Note: Due to the speed of the clock distribution path (as fast as ~325 ps period) and the slow slew rate of the SYNC, the exact VCO cycle at which the SYNC is asserted or unasserted by the SYNC is undefined. The timing diagrams show a sharp transition of the SYNC to clarify functionality.

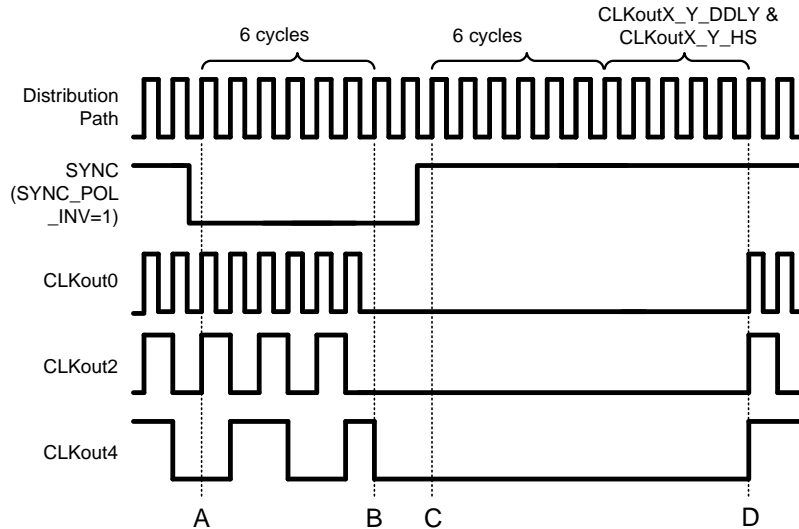
### Avoiding clock output interruption due to SYNC

Any CLKout groups that have their NO\_SYNC\_CLKoutX\_Y bits set will be unaffected by the SYNC event. It is possible to perform a SYNC operation with the NO\_SYNC\_CLKoutX\_Y bits cleared, then set the NO\_SYNC\_CLKoutX\_Y bits so that the selected clocks will not be affected by a future SYNC. Future SYNC events will not effect these clocks but will still cause the newly synchronized clocks to be re-synchronized using the currently programmed digital delay values. When this happens, the phase relationship between the first group of synchronized clocks and the second group of synchronized clocks will be undefined unless the SYNC pulse is qualified by an output clock. See [Section 7.9.2.1](#).

### SYNC Timing

When discussing the timing of the SYNC function, one cycle refers to one period of the clock distribution path.



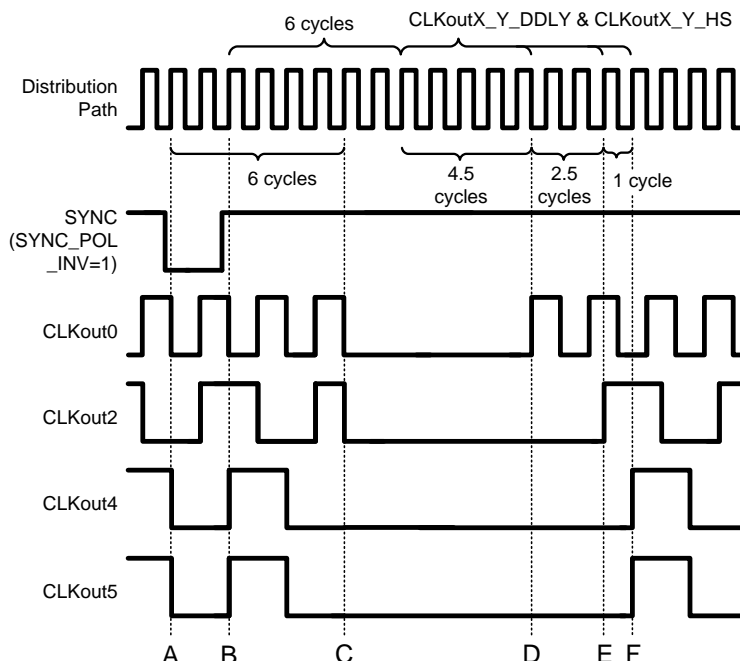


CLKout0\_1\_DIV = 1 (valid only for external VCO mode)  
 CLKout2\_3\_DIV = 2  
 CLKout4\_5\_DIV = 4  
 The digital delay for all clock outputs is 5  
 The digital delay half step for all clock outputs is 0  
 SYNC\_QUAL = 0 (No qualification)

**Figure 7-2. Clock Output synchronization using the SYNC pin (Active Low)**

Refer to [Figure 7-2](#) during this discussion on the timing of SYNC. SYNC must be asserted for greater than one clock cycle of the clock distribution path to latch the SYNC event. After SYNC is asserted, the SYNC event is latched on the rising edge of the distribution path clock, at time A. After this event has been latched, the outputs will not reflect the low state for 6 cycles, at time B. Due to the asynchronous nature of SYNC with respect to the output clocks, it is possible that a glitch pulse could be created when the clock output goes low from the SYNC event. This is shown by CLKout4 in [Figure 7-2](#) and CLKout2 in [Figure 7-3](#). See [Section 7.9.2.1.2](#) for more information on synchronizing relative to an output clock to eliminate or minimize this glitch pulse.

After SYNC becomes unasserted the event is latched on the following rising edge of the distribution path clock, time C. The clock outputs will rise at time D, coincident with a rising distribution clock edge that occurs after 6 cycles plus as many more cycles as programmed by the digital delay for that clock output. Therefore, the soonest a clock output will become high is 11 cycles after the SYNC unassertion event registration, time C, when the smallest digital delay value of 5 is set. If CLKoutX\_Y\_HS = 1 and CLKoutX\_Y\_DDLY = 5, then the clock output will rise 10.5 cycles after SYNC is unassertion event registration.



CLKout0\_1\_DIV = 2, CLKout0\_1\_DDLY = 5  
 CLKout2\_3\_DIV = 4, CLKout2\_3\_DDLY = 7  
 CLKout4\_5\_DIV = 4, CLKout4\_5\_DDLY = 8  
 CLKout0\_1\_HS = 1  
 CLKout2\_3\_HS = 0  
 CLKout4\_5\_HS = 0  
 SYNC\_QUAL = 0 (No qualification)

**Figure 7-3. Clock Output synchronization using the SYNC pin (Active Low)**

Figure 7-3 illustrates the timing with different digital delays programmed.

- Time A) SYNC assertion event is latched.
- Time B) SYNC unassertion latched.
- Time C) All outputs toggle and remain low. A glitch pulse can occur at this time as shown by CLKout2.
- Time D) After  $6 + 4.5 = 10.5$  cycles CLKout0 rises. This is the shortest time from SYNC unassertion registration to clock rising edge possible.
- Time E) After  $6 + 7 = 13$  cycles CLKout2 rises. CLKout2 and CLKout4, 5 are programmed for quadrature operation.
- Time F) After  $6 + 8 = 14$  cycles CLKout4 and 5 rise. Since CLKout4 and 5 are driven by the same clock divider and delay circuit, their timing is always the same.

### 7.9.2.1 DYNAMICALLY PROGRAMMING DIGITAL DELAY

To use dynamic digital delay synchronization qualification set `SYNC_QUAL = 1`. This causes the SYNC pulse to be qualified by a clock output so that the SYNC event occurs after a specified time from a clock output transition. This allows the relative adjustment of clock output phase in real-time with no or minimum interruption of clock outputs. Hence the term dynamic digital delay.

Note that changing the phase of a clock output requires momentarily altering in the rate of change of the clock output phase and therefore by definition results in a frequency distortion of the signal.

Without qualifying the SYNC with an output clock, the newly synchronized clocks would have a random and unknown digital delay (or phase) with respect to clock outputs not currently being synchronized.

#### Absolute vs. Relative Dynamic Digital Delay

The clock used for qualification of SYNC is selected with the feedback mux (`FEEDBACK_MUX`).

If the clock selected by the feedback mux has its NO\_SYNC\_CLKoutX\_Y = 1, then an **absolute dynamic digital delay** adjustment will be performed during a SYNC event and the digital delay of the feedback clock **will not** be adjusted.

If the clock selected by the feedback mux has its NO\_SYNC\_CLKoutX\_Y = 0, then a self-referenced or **relative dynamic digital delay** adjustment will be performed during a SYNC event and the digital delay of the feedback clock **will** be adjusted.

Clocks with NO\_SYNC\_CLKoutX\_Y = 1 always operate without interruption.

### Dynamic Digital Delay and 0-Delay Mode

When using a 0-delay mode **absolute** dynamic digital delay is recommended. Using **relative** dynamic digital delay with a 0-delay mode may result in a momentary clock loss on the adjusted clock also being used for 0-delay feedback that may result in PLL1 DLD becoming low. This may result in HOLDOVER mode being activated depending upon device configuration.

### SYNC and Minimum Step Size

The minimum step size adjustment for digital delay is half a clock distribution path cycle. This is achieved by using the CLKoutX\_Y\_HS bit. The CLKoutX\_Y\_HS bit change effect is immediate without the need for SYNC. To shift digital delay using CLKoutX\_Y\_DDLY a SYNC signal must be generated for the change to take effect.

### Programming Overview

To dynamically adjust the digital delay with respect to an existing clock output the device should be programmed as follows:

- Set SYNC\_QUAL = 1 for clock output qualification.
- Set CLKout4\_5\_PD = 0. Required for proper operation of SYNC\_QUAL = 1.
- Set EN\_FEEDBACK\_MUX = 1 to enable the feedback buffer.
- Set FEEDBACK\_MUX to the clock output that the newly synchronized clocks will be qualified by.
- Set NO\_SYNC\_CLKoutX\_Y = 1 for the output clocks that will continue to operate during the SYNC event. There is no interruption of output on these clocks.
  - If FEEDBACK\_MUX selects a clock output with NO\_SYNC\_CLKoutX\_Y = 1, then **absolute dynamic digital delay** is performed.
  - If FEEDBACK\_MUX selects a clock output with NO\_SYNC\_CLKoutX\_Y = 0, then self-referenced or **relative dynamic digital delay** is performed.
- The SYNC\_EN\_AUTO bit may be set to cause a SYNC event to begin when register R0 to R5 is programmed. The auto SYNC feature is a convenience since does not require the application to manually assert SYNC by toggling the SYNC\_POL\_INV bit or the SYNC pin when changing digital delay. However, under the following condition a special programming sequence is required if SYNC\_EN\_AUTO = 1:
  - The CLKoutX\_Y\_DDLY value being set in the programmed register is 13 or more.
- Under the following condition a SYNC\_EN\_AUTO must = 0:
  - If the application requires a digital delay resolution of half a clock distribution path cycle in **relative** dynamic digital delay mode because the HS bit must be fixed per [Table 7-8](#) for a qualifying clock.

### Internal Dynamic Digital Delay Timing

To dynamically adjust digital delay a SYNC must occur. Once the SYNC is qualified by an output clock, 3 cycles later an internal one shot pulse will occur. The width of the one shot pulse is 3 cycles. This internal one shot pulse will cause the outputs to turn off and then back on with a fixed delay with respect to the falling edge of the qualification clock. This allows for dynamic adjustments of digital delay with respect to an output clock.

The qualified SYNC timing is shown in [Figure 7-4](#) for absolute dynamic digital delay and [Figure 7-5](#) for relative dynamic digital delay.

### Other Timing Requirements

When adjusting digital delay dynamically, the falling edge of the qualifying clock selected by the FEEDBACK\_MUX must coincide with the falling edge of the clock distribution path. For this requirement to be met, program the CLKoutX\_Y\_HS value of the qualifying clock group according to [Table 7-8](#).

**Table 7-8. Half Step programming requirement of qualifying clock during SYNC event**

| Distribution Path Frequency | CLKoutX_Y_DIV value | CLKoutX_Y_HS                |
|-----------------------------|---------------------|-----------------------------|
| ≥ 1.8 GHz                   | Even                | Must = 1 during SYNC event. |
|                             | Odd                 | Must = 0 during SYNC event. |
| < 1.8 GHz                   | Even                | Must = 0 during SYNC event. |
|                             | Odd                 | Must = 1 during SYNC event. |

#### 7.9.2.1.1 Absolute Dynamic Digital Delay

Absolute dynamic digital delay can be used to program a clock output to a specific phase offset from another clock output.

Pros:

- Simple direct phase adjustment with respect to another clock output.
- CLKoutX\_Y\_HS will remain constant for qualifying clock.
  - Can easily use auto sync feature (SYNC\_EN\_AUTO = 1) when digital delay adjustment requires half step digital delay requirements.
- Can be used with 0-delay mode.

Cons:

- For some phase adjustments there may be a glitch pulse due to SYNC assertion.
  - For example see CLKout4 in [Figure 7-2](#) and CLKout2 in [Figure 7-3](#).

##### 7.9.2.1.1.1 ABSOLUTE DYNAMIC DIGITAL DELAY - EXAMPLE

To illustrate the absolute dynamic digital delay adjust procedure, consider the following example.

#### System Requirements:

- VCO Frequency = 2949.12 MHz
- CLKout0 = 983.04 MHz (CLKout0\_1\_DIV = 3)
- CLKout2 = 491.52 MHz (CLKout2\_3\_DIV = 6)
- CLKout4 = 245.76 MHz (CLKout4\_5\_DIV = 12)
- For all clock outputs during initial programming:
  - CLKoutX\_Y\_DDLY = 5
  - CLKoutX\_Y\_HS = 1
  - NO\_SYNC\_CLKoutX\_Y = 0

The application requires the 491.52 MHz clock to be stepped in 30 degree steps (~169.5 ps), which is the minimum step resolution allowable by the clock distribution path requiring use of the half step bit (CLKoutX\_Y\_HS). That is  $1 / 2949.52 \text{ MHz} / 2 = \sim 169.5 \text{ ps}$ . During the stepping of the 491.52 MHz clock the 983.04 MHz and 245.76 MHz clock must not be interrupted.

**Step 1:** The device is programmed from register R0 to R30 with values that result in the device being locked and operating as desired, see the system requirements above. The phase of all the output clocks are aligned because all the digital delay and half step values were the same when the SYNC was generated by programming register R30. The timing of this is as shown in [Figure 7-2](#).

**Step 2:** Now the registers will be programmed to prepare for changing digital delay (or phase) dynamically.

**Table 7-9. Register Setup for Absolute Dynamic Digital Delay Example**

| Register                   | Purpose   |
|----------------------------|---|
| SYNC_QUAL = 1              | Use a clock output for qualifying the SYNC pulse for dynamically adjusting digital delay.   |
| EN_SYNC = 1 (default)      | Required for SYNC functionality.  |
| CLKout4_5_PD = 0           | Required when SYNC_QUAL = 1. CLKout4 and/or CLKout5 outputs may be powered down or in use.  |
| EN_FEEDBACK_MUX = 1        | Enable the feedback mux for SYNC operation for dynamically adjusting digital delay.   |
| FEEDBACK_MUX = 2 (CLKout4) | Use the fixed 245.76 MHz clock as the SYNC qualification clock.   |
| NO_SYNC_CLKout0_1 = 1      | This clock output (983.04 MHz) won't be affected by SYNC. It will always operate without interruption.  |
| NO_SYNC_CLKout4_5 = 1      | This clock output (245.76 MHz) won't be affected by SYNC. It will always operate without interruption. This clock will also be the <i>qualifying clock</i> in this example. |
| CLKout4_5_HS = 1           | Since CLKout4 is the qualifying clock and CLKoutX_Y_DIV is even, the half step bit must be set to 1. See <a href="#">Table 7-8</a> .  |
| SYNC_EN_AUTO = 1           | Automatic generation of SYNC is allowed for this case.  |

After the registers in [Table 7-9](#) have been programmed, the application may now dynamically adjust the digital delay of CLKout2 (491.52 MHz).

**Step 3:** Adjust digital delay of CLKout2.

Refer to [Table 7-10](#) for the programming values to set a specified phase offset from the absolute reference clock. [Table 7-10](#) is dependant upon the qualifying clock divide value of 12, refer to [Section 9.7](#) for information on creating tables for any divide value.

**Table 7-10. Programming for Absolute Digital Delay Adjustment**

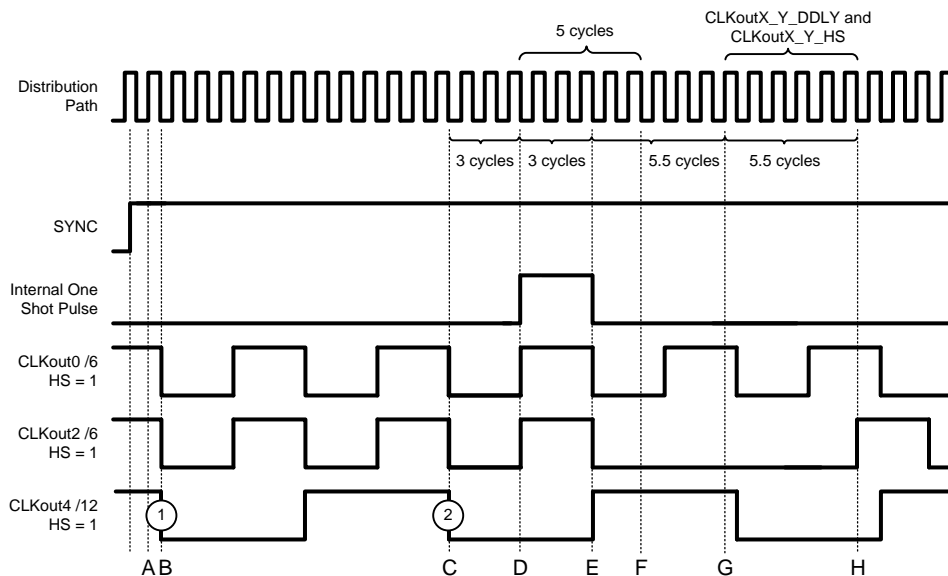
| Degrees of Adjustment from initial 491.52 MHz phase |              | Programming                           |
|---|--------------|---------------------------------------|
| +/-0 or +/-360 degrees                              |              | CLKout2_3_DDLY = 7; CLKout2_3_HS = 1  |
| 30 degrees  | -330 degrees | CLKout2_3_DDLY = 7; CLKout2_3_HS = 0  |
| 60 degrees  | -300 degrees | CLKout2_3_DDLY = 8; CLKout2_3_HS = 1  |
| 90 degrees  | -270 degrees | CLKout2_3_DDLY = 8; CLKout2_3_HS = 0  |
| 120 degrees   | -240 degrees | CLKout2_3_DDLY = 9; CLKout2_3_HS = 1  |
| 150 degrees   | -210 degrees | CLKout2_3_DDLY = 9; CLKout2_3_HS = 0  |
| 180 degrees   | -180 degrees | CLKout2_3_DDLY = 10; CLKout2_3_HS = 1 |
| 210 degrees   | -150 degrees | CLKout2_3_DDLY = 10; CLKout2_3_HS = 0 |
| 240 degrees   | -120 degrees | CLKout2_3_DDLY = 5; CLKout2_3_HS = 1  |
| 270 degrees   | -90 degrees  | CLKout2_3_DDLY = 5; CLKout2_3_HS = 0  |
| 300 degrees   | -60 degrees  | CLKout2_3_DDLY = 6; CLKout2_3_HS = 1  |
| 330 degrees   | -30 degrees  | CLKout2_3_DDLY = 6; CLKout2_3_HS = 0  |

After setting the new digital delay values, the act of programming R1 will start a SYNC automatically because SYNC\_EN\_AUTO = 1.

If the user elects to reduce the number of SYNCs because they are not required when only CLKout2\_3\_HS is set, then SYNC\_EN\_AUTO is = 0 and the SYNC may now be generated by toggling the SYNC pin or by toggling the SYNC\_POL\_INV bit. Because of the internal one shot pulse, no strict timing of the SYNC pin or SYNC\_POL\_INV bit is required.

After the SYNC event, the clock output will adjust according to [Table 7-10](#). See [Figure 7-4](#) for a detailed view of the timing diagram. The timing diagram critical points are:

- Time A) SYNC assertion event is latched.
- Time B) First qualifying falling clock output edge.
- Time C) Second qualifying falling clock output edge.
- Time D) Internal one shot pulse begins. 5 cycles later clock outputs will be forced low
- Time E) Internal one shot pulse ends. 5 cycles + digital delay cycles later the synced clock outputs rise.
- Time F) Clock outputs are forced low. (CLKout2 is already low).
- Time G) Beginning of digital delay cycles.
- Time H) For CLKout2\_3\_DDLY = 6; the clock output rises now.



**Figure 7-4. Absolute Dynamic Digital Delay Programming Example (SYNC\_QUAL = 1, Qualify with clock output)**

### 7.9.2.1.2 Relative Dynamic Digital Delay

Relative dynamic digital delay can be used to program a clock output to a specific phase offset from another clock output.

Pros:

- Simple direct phase adjustment with respect to same clock output.
- The clock output will always behave the same during digital delay adjustment transient. For some divide values there will be no glitch pulse.

Cons:

- For some clock divide values there may be a glitch pulse due to SYNC assertion.
- Adjustments of digital delay requiring the half step bit (CLKoutX\_Y\_HS) for finer digital delay adjust is complicated.
- Use with 0-delay mode may result in PLL1 DLD becoming low and HOLDOVER mode becoming activated.
  - DISABLE\_DLD1\_DET can be set to prevent HOLDOVER from becoming activated due to PLL1 DLD becoming low.

### 7.9.2.1.2.1 RELATIVE DYNAMIC DIGITAL DELAY - EXAMPLE

To illustrate the relative dynamic digital delay adjust procedure, consider the following example.

#### System Requirements:

- VCO Frequency = 2949.12 MHz
- CLKout0 = 983.04 MHz (CLKout0\_1\_DIV = 3)
- CLKout2 = 491.52 MHz (CLKout2\_3\_DIV = 6)
- CLKout4 = 491.52 MHz (CLKout4\_5\_DIV = 6)
- For all clock outputs during initial programming:
  - CLKoutX\_Y\_DDLY = 5
  - CLKoutX\_Y\_HS = 0
  - NO\_SYNC\_CLKoutX\_Y = 0

The application requires the 491.52 MHz clock to be stepped in 30 degree steps (~169.5 ps), which is the minimum step resolution allowable by the clock distribution path. That is  $1 / 2949.52 \text{ MHz} / 2 = \sim 169.5 \text{ ps}$ . During the stepping of the 491.52 MHz clocks the 983.04 MHz clock must not be interrupted.

**Step 1:** The device is programmed from register R0 to R30 with values that result in the device being locked and operating as desired, see the system requirements above. The phase of all the output clocks are aligned because all the digital delay and half step values were the same when the SYNC was generated by programming register R30. The timing of this is as shown in [Figure 7-2](#).

**Step 2:** Now the registers will be programmed to prepare for changing digital delay (or phase) dynamically.

| Register                   | Purpose  |
|----------------------------|--|
| SYNC_QUAL = 1              | Use clock output for qualifying the SYNC pulse for dynamically adjusting digital delay.  |
| EN_SYNC = 1 (default)      | Required for SYNC functionality.   |
| CLKout4_5_PD = 0           | Required when SYNC_QUAL = 1. CLKout4 and/or CLKout5 outputs may be powered down or in use.   |
| EN_FEEDBACK_MUX = 1        | Enable the feedback mux for SYNC operation for dynamically adjusting digital delay.  |
| FEEDBACK_MUX = 1 (CLKout2) | Use the clock itself as the SYNC qualification clock.  |
| NO_SYNC_CLKout0_1 = 1      | This clock output (983.04 MHz) won't be affected by SYNC. It will always operate without interruption.   |
| NO_SYNC_CLKout4_5 = 1      | CLKout3's phase is not to change with respect to CLKout0.  |
| SYNC_EN_AUTO = 0 (default) | Automatic generation of SYNC is not allowed because of the half step requirement in relative dynamic digital delay mode. SYNC must be generated manually by toggling the SYNC_POL_INV bit or the SYNC pin. |

After the above registers have been programmed, the application may now dynamically adjust the digital delay of the 491.52 MHz clocks.

**Step 3:** Adjust digital delay of CLKout2 by one step which is 30 degrees or ~169.5 ps.

Refer to [Table 7-11](#) for the programming sequence to step one half clock distribution period forward or backwards. Refer to [Section 9.7](#) for more information on how to calculate digital delay and half step values for other cases.

To fulfill the qualifying clock output half step requirement in [Table 7-8](#) when dynamically adjusting digital delay, the CLKoutX\_Y\_HS bit must be cleared for clocks with even divides. So before any dynamic digital delay adjustment, CLKoutX\_Y\_HS must be clear because the clock divide value is even. To achieve the final required digital delay adjustment, the CLKoutX\_Y\_HS bit may set after SYNC.

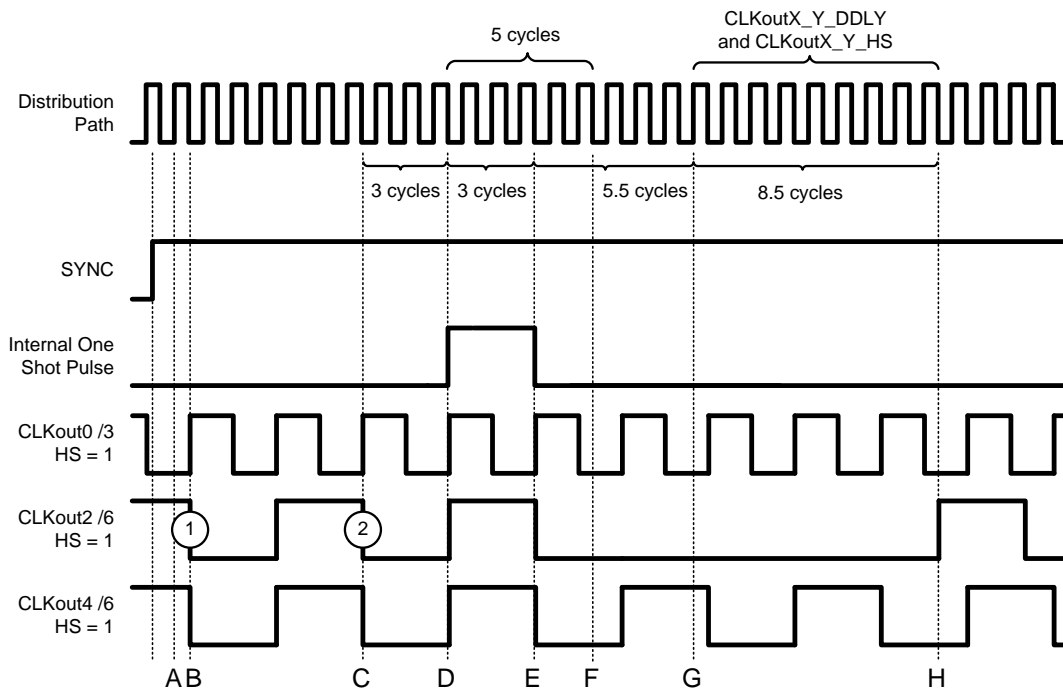


**Table 7-11. Programming sequence for one step adjust**

| Step direction and current HS state                          | Programming Sequence   |
|--|--|
| Adjust clock output one step forward.<br>CLKout2_3_HS is 0.  | 1. CLKout2_3_HS = 1.   |
| Adjust clock output one step forward.<br>CLKout2_3_HS is 1.  | 1. CLKout2_3_DDLY = 9.<br>2. Perform SYNC event.<br>3. CLKout2_3_HS = 0. |
| Adjust clock output one step backward.<br>CLKout2_3_HS is 0. | 1. CLKout2_3_HS = 1.<br>2. CLKout2_3_DDLY = 5.<br>3. Perform SYNC event. |
| Adjust clock output one step backward.<br>CLKout2_3_HS is 1. | 1. CLKout2_3_HS = 0.   |

After programming the updated CLKout2\_3\_DDLY and CLKout2\_3\_HS values, perform a SYNC event. The SYNC may be generated by toggling the SYNC pin or by toggling the SYNC\_POL\_INV bit. Because of the internal one shot pulse, no strict timing of the SYNC pin or SYNC\_POL\_INV bit is required. After the SYNC event, the clock output will be at the specified phase. See [Figure 7-5](#) for a detailed view of the timing diagram. The timing diagram critical points are:

- Time A) SYNC assertion event is latched.
- Time B) First qualifying falling clock output edge.
- Time C) Second qualifying falling clock output edge.
- Time D) Internal one shot pulse begins. 5 cycles later clock outputs will be forced low.
- Time E) Internal one shot pulse ends. 5 cycles + digital delay cycles later the synced clock outputs rise.
- Time F) Clock outputs are forced low. (CLKouts are already low).
- Time G) Beginning of digital delay cycles.
- Time H) For CLKout2\_3\_DDLY = 9; the clock output rises now.



(SYNC\_QUAL = 1, Qualify with clock output)  
Starting condition is after half step is removed (CLKout2\_3\_HS = 0).

**Figure 7-5. Relative Dynamic Digital Delay Programming Example, 2nd adjust**



### 7.9.3 0-Delay Mode

When 0-delay mode is enabled the clock output selected by the Feedback Mux is connected to the PLL1 N counter to ensure a fixed phase relationship between the selected CLKin and the fed back CLKout. When all the clock outputs are synced together, all the clock outputs will share the same fixed phase relationship between the selected CLKin and the fed back CLKout. The feedback can be internal or external using FBCLKin port.

When 0-delay mode is enabled the lowest frequency clock output is fed back to the Feedback Mux to ensure a repeatable fixed CLKin to CLKout phase relationship between all clock outputs.

If a clock output that is not the lowest frequency output is selected for feedback, then clocks with lower frequencies will have an unknown phase relationship with respect the other clocks and clock input. There will be a number of possible phase relationships equal to  $\text{Feedback\_Clock\_Frequency} / \text{Lower\_Clock\_Frequency}$  that may occur.

The Feedback Mux selects the even clock output of any clock group for internal feedback or the FBCLKin port for external 0-delay feedback. The even clock can remain powered down as long as the CLKoutX\_Y\_PD bit is = 0 for its clock group.

To use 0-delay mode, the bit EN\_FEEDBACK\_MUX must be set (=1) to power up the feedback mux.

See [Section 9.2](#) for more information on programming PLL1\_N for 0-delay mode.

When using an external VCO mode, internal 0-delay feedback must be used since the FBCLKin port is shared with the Fin input.

[Table 7-12](#) outlines several registers to program for 0-delay mode.

**Table 7-12. Programming 0-Delay Mode**

| Register                            | Purpose  |
|-------------------------------------|--|
| MODE = 2 or 5                       | Select one of the 0-delay modes for device.  |
| EN_FEEDBACK_MUX = 1                 | Enable feedback mux.   |
| FEEDBACK_MUX = Application Specific | Select CLKout or FBCLKin for 0-delay feedback.   |
| CLKoutX_Y_DIV                       | The divide value of the clock selected by FEEDBACK_MUX is important for PLL2 N value calculation |
| PLL1_N                              | PLL1_N value used with CLKoutX_Y_DIV in loop.  |

## 8 General Programming Information

LMK048xx devices are programmed using 32-bit registers. Each register consists of a 5-bit address field and 27-bit data field. The address field is formed by bits 0 through 4 (LSBs) and the data field is formed by bits 5 through 31 (MSBs). The contents of each register is clocked in MSB first (bit 31), and the LSB (bit 0) last. During programming, the L<sub>Eu</sub>Wire signal should be held *low*. The serial data is clocked in on the rising edge of the CLK<sub>u</sub>Wire signal. After the LSB (bit 0) is clocked in the L<sub>Eu</sub>Wire signal should be toggled *low-to-high-to-low* to latch the contents into the register selected in the address field. It is recommended to program registers in numeric order, for example R0 to R16, and R24 to R31 to achieve proper device operation. [Figure 3-1](#) illustrates the serial data timing sequence.

To achieve proper frequency calibration, the OSC<sub>in</sub> port must be driven with a valid signal before programming register R30. Changes to PLL2 R divider or the OSC<sub>in</sub> port frequency require register R30 to be reloaded in order to activate the frequency calibration process.

### 8.1 SPECIAL PROGRAMMING CASE FOR R0 to R5 for CLK<sub>out</sub>X\_Y\_DIV & CLK<sub>out</sub>X\_Y\_DDLY

In some cases when programming register R0 to R5 to change the CLK<sub>out</sub>X\_Y\_DIV divide value or CLK<sub>out</sub>X\_Y\_DDLY delay value, 3 additional CLK<sub>u</sub>Wire cycles must occur after loading the register for the newly programmed divide or delay value to take effect. These special cases include:

- When CLK<sub>out</sub>X\_Y\_DIV is > 25.
- When CLK<sub>out</sub>X\_Y\_DDLY is > 12. Note, loading the digital delay value only prepares for a future SYNC event.

Also, since SYNC\_EN\_AUTO bit = 1 automatically generates a SYNC on the falling edge of LE when R0 to R5 is programmed, further programming considerations must be made when SYNC\_EN\_AUTO = 1.

These special programming cases requiring the additional three clock cycles may be properly programmed by one of the following methods shown in [Table 8-1](#).

**Table 8-1. R0 to R5 Special Case**

| CLK <sub>out</sub> X_Y_DIV & CLK <sub>out</sub> X_Y_DDLY             | SYNC_EN_AUTO | Programming Method  |
|--|--------------|---|
| CLK <sub>out</sub> X_Y_DIV ≤ 25 and CLK <sub>out</sub> X_Y_DDLY ≤ 12 | 0 or 1       | No Additional Clocks Required (Normal)                                      |
| CLK <sub>out</sub> X_Y_DIV > 25 or CLK <sub>out</sub> X_Y_DDLY > 12  | 0            | Three Extra CLK <sub>u</sub> Wire Clocks (Or program another register)      |
| CLK <sub>out</sub> X_Y_DIV > 25 or CLK <sub>out</sub> X_Y_DDLY > 12  | 1            | Three Extra CLK <sub>u</sub> Wire Clocks while L <sub>Eu</sub> Wire is High |

#### Method: No Additional Clocks Required (Normal)

No special consideration to CLK<sub>u</sub>Wire is required when changing divide value to ≤ 25, digital delay value to ≤ 12, or when the digital delay and divide value do not change. See MICROWIRE timing [Figure 3-1](#).

#### Method: Three Extra CLK<sub>u</sub>Wire Clocks

Three extra clocks must be provided before CLK<sub>out</sub>X\_Y\_DIV > 25 or CLK<sub>out</sub>X\_Y\_DDLY > 12 take effect. See MICROWIRE timing [Figure 3-2](#).

Also, by programming another register the three clock requirement can be satisfied.

#### Method: Three Extra CLK<sub>u</sub>Wire Clocks with L<sub>Eu</sub>Wire Asserted

When SYNC\_EN\_AUTO = 1 the falling edge of L<sub>Eu</sub>Wire will generate a SYNC event. CLK<sub>out</sub>X\_Y\_DIV and CLK<sub>out</sub>X\_Y\_DDLY values must be updated before the SYNC event occurs. So 3 CLK<sub>u</sub>Wire rising edges must occur before L<sub>Eu</sub>Wire goes low. See MICROWIRE timing [Figure 3-3](#).

## Initial Programming Sequence

During the recommended programming sequence the device is programmed in order from R0 to R31, so it is expected at least one additional register will be programmed after programming the last CLKoutX\_Y\_DIV or CLKoutX\_Y\_DDLY value in R0 to R5. This will result in the extra needed CLKuWire rising edges, so this special note is of little concern.

If programming R0 to R5 to change CLKout frequency or digital delay or dynamic digital delay at a later time in the application, care must be taken to provide these extra CLKuWire cycles to properly load the new divide and/or delay values.

### 8.1.1 Example

In this example, all registers have been programmed, the PLLs are locked. An LMK04808 has been generating a clock output frequency of 61.44 MHz on CLKout4 using a VCO frequency of 2949.12 MHz and a divide value of 48. SYNC\_EN\_AUTO = 0. At a later time the application requires a 30.72 MHz output on CLKout4. By reprogramming register R4 with CLKout4\_5\_DIV = 96 twice, the divide value of 96 is set for clock outputs 4 and 5 which results in an output frequency of 30.72 MHz ( $2949.12 \text{ MHz} / 96 = 30.72 \text{ MHz}$ ) on CLKout4.

In this example the required 3 CLKuWire cycles were achieved by reprogramming the R4 register with the same value twice.

## 8.2 RECOMMENDED PROGRAMMING SEQUENCE

Registers are programmed in numeric order with R0 being the first and R31 being the last register programmed. The recommended programming sequence involves programming R0 with the reset bit (b17) set to 1 to ensure the device is in a default state. If R0 is programmed again, the reset bit must be cleared to 0 during the programming of R0.

### 8.2.1 Overview

- Program R0 with RESET bit = 1. This ensures that the device is configured with default settings. When RESET = 1, all other R0 bits are ignored.
  - If R0 is programmed again during the initial configuration of the device, the RESET bit must be cleared.
- R0 through R5: CLKouts.
  - Program as necessary to configure the clock outputs, CLKout0 to CLKout11 as desired. These registers configure clock output controls such as powerdown, digital delay and divider value, analog delay select, and clock source select.
- R6 through R8: CLKouts.
  - Program as necessary to configure the clock outputs, CLKout0 to CLKout11 as desired. These registers configure the output format for each clock outputs and the analog delay for the clock output groups.
- R9: Required programming
  - Program this register as shown in the register map for proper operation.
- R10: OSCouts, VCO divider, and 0-delay.
  - Enable and configure clock outputs OSCout0/1.
  - Set and select VCO divider (VCO bypass is recommended).
  - Set 0-delay feedback source if used.
- R11: Part mode, SYNC, and XTAL.
  - Program to configure the mode of the part, to configure SYNC functionality and pin, and to enable crystal mode.

- R12: Pins, SYNC, and holdover mode.
  - Status\_LD pin, more SYNC options to generate a SYNC upon PLL1 and/or PLL2 lock detect.
  - Enable clock features such as holdover.
- R13: Pins, holdover mode, and CLKins.
  - Status\_HOLDOVER, Status\_CLKin0, and Status\_CLKin1 pin controls.
  - Enable clock inputs for use in specific part modes.
- R14: Pins, LOS, CLKins, and DAC.
  - Status\_CLKin1 pin control.
  - Loss of signal detection, CLKin type, DAC rail detect enable and high and low trip points.
- R15: DAC and holdover mode.
  - Program to enable and set the manual DAC value.
  - HOLDOVER mode options.
- R16: Crystal amplitude.
  - Increasing XTAL\_LVL can improve tunable crystal phase noise performance.
- R24: PLL1 and PLL2.
  - PLL1 N and R delay and PLL1 digital lock delay value.
  - PLL2 integrated loop filter.
- R25: DAC and PLL1.
  - Program to configure DAC update clock divider and PLL1 digital lock detect count.
- R26: PLL2.
  - Program to configure PLL2 options.
- R27: CLKins and PLL1.
  - Clock input pre-dividers.
  - Program to configure PLL1 options.
- R28: PLL1 and PLL2.
  - Program to configure PLL2 R and PLL1 N.
- R29: OSCin and PLL2.
  - Program to configure oscillator input frequency, PLL2 fast phase detector frequency mode, and PLL2 N calibration value.
- R30: PLL2.
  - Program to configure PLL2 prescaler and PLL2 N value.
- R31: uWire lock.
  - Program to set the uWire\_LOCK bit.

### 8.3 READBACK

At no time should the MICROWIRE registers be programmed to any value other than what is specified in the datasheet.

For debug of the MICROWIRE interface, it is recommended to simply program an output pin mux to active low and then toggle the output type register between output and inverting output while observing the output pin for a low to high transition. For example, to verify MICROWIRE programming, set the LD\_MUX = 0 (Low) and then toggle the LD\_TYPE register between 3 (Output, push-pull) and 4 (Output inverted, push-pull). The result will be that the Status\_LD pin will toggle from low to high.

Readback from the MICROWIRE programming registers is available. The MICROWIRE readback function can be enabled on the Status\_LD, Status\_HOLDOVER, Status\_CLKin0, Status\_CLKin1, or SYNC pin by programming the corresponding MUX register to "uWire Readback" and the corresponding TYPE register to "Output (push-pull)." Power on reset defaults the Status\_HOLDOVER pin to "uWire Readback."

Figure 3-4 illustrates the serial data timing sequence for a readback operation for both cases of READBACK\_LE = 0 (POR default) and READBACK\_LE = 1.

To perform a readback operation first set the register to be read back by programming the READBACK\_ADDR register. Then after any MICROWIRE write operation, with the LEuWire pin held low continue to clock the CLKuWire pin. On every rising edge of the CLKuWire pin a new data bit is clocked onto the any pins programmed for uWire Readback. If the READBACK\_LE bit is set, the LEuWire pin should be left high after LEuWire rising edge while continuing to clock the CLKuWire pin.

It is allowable to perform a register read back in the same MICROWIRE operation which set the READBACK\_ADDR register value.

Data is clocked out MSB first. After 27 clocks all the data values will have been read and the read operation is complete. If READBACK\_LE = 1, the LEuWire line may now be lowered. It is allowable for the CLKuWire pin to be clocked additional cycles, but the data on the readback pin will be invalid.

CLKuWire must be low before the falling edge of LEuWire.

### 8.3.1 Readback - Example

To readback register R3 perform the following steps:

- Write R31 with READBACK\_ADDR = 3; READBACK\_LE = 0. DATAuWire and CLKuWire are toggled as shown in Figure 3-1 with new data being clocked in on rising edges of CLKuWire
- Toggle LEuWire high and then low as shown in Figure 3-1 and Figure 3-4. LEuWire is returned low because READBACK\_LE = 0.
- Toggle CLKuWire high and then low 27 times to read back all 27 bits of register R3. Data is read MSB first. Data is valid on falling edge of CLKuWire.
- Read operation is complete.

## 8.4 REGISTER MAP AND READBACK REGISTER MAP

Table 8-2 provides the register map for device programming. Normally any register can be read from the same data address it is written to. However, READBACK\_LE has a **different readback address**. Also, the DAC\_CNT register is a read only register. Table 8-3 shows the address for READBACK\_LE and DAC\_CNT. Bits marked as reserved are undefined upon readback.

Observe that only the DATA bits are readback during a readback which can result in an offset of 5 bits between the two register tables.

**Table 8-2. Register Map**

| Register | 31                   | 30                  | 29                | 28                   | 27                       | 26 | 25                   | 24 | 23 | 22                   | 21 | 20 | 19                     | 18 | 17 | 16        | 15                   | 14                     | 13 | 12 | 11 | 10 | 9 | 8 | 7 | 6 | 5             | 4 | 3 | 2 | 1 | 0 |
|----------|----------------------|---------------------|-------------------|----------------------|--------------------------|----|----------------------|----|----|----------------------|----|----|------------------------|----|----|-----------|----------------------|------------------------|----|----|----|----|---|---|---|---|---------------|---|---|---|---|---|
|          | Data [26:0]          |                     |                   |                      |                          |    |                      |    |    |                      |    |    |                        |    |    |           |                      |                        |    |    |    |    |   |   |   |   | Address [4:0] |   |   |   |   |   |
| R0       | CLKout0_1_PD         | 0                   | CLKout1_ADLY_SEL  | CLKout0_ADLY_SEL     | CLKout0_1_DDLY [27:18]   |    |                      |    |    |                      |    |    |                        |    |    | RESET     | CLKout0_1_HS         | CLKout0_1_DIV [15:5]   |    |    |    |    |   |   |   |   |               | 0 | 0 | 0 | 0 | 0 |
| R1       | CLKout2_3_PD         | 0                   | CLKout3_ADLY_SEL  | CLKout2_ADLY_SEL     | CLKout2_3_DDLY [27:18]   |    |                      |    |    |                      |    |    |                        |    |    | POWERDOWN | CLKout2_3_HS         | CLKout2_3_DIV [15:5]   |    |    |    |    |   |   |   |   |               | 0 | 0 | 0 | 0 | 1 |
| R2       | CLKout4_5_PD         | 0                   | CLKout5_ADLY_SEL  | CLKout4_ADLY_SEL     | CLKout4_5_DDLY [27:18]   |    |                      |    |    |                      |    |    |                        |    |    | 0         | CLKout4_5_HS         | CLKout4_5_DIV [15:5]   |    |    |    |    |   |   |   |   |               | 0 | 0 | 0 | 1 | 0 |
| R3       | CLKout6_7_PD         | CLKout6_7_OSCin_Sel | CLKout7_ADLY_SEL  | CLKout6_ADLY_SEL     | CLKout6_7_DDLY [27:18]   |    |                      |    |    |                      |    |    |                        |    |    | 0         | CLKout6_7_HS         | CLKout6_7_DIV [15:5]   |    |    |    |    |   |   |   |   |               | 0 | 0 | 0 | 1 | 1 |
| R4       | CLKout8_9_PD         | CLKout8_9_OSCin_Sel | CLKout9_ADLY_SEL  | CLKout8_ADLY_SEL     | CLKout8_9_DDLY [27:18]   |    |                      |    |    |                      |    |    |                        |    |    | 0         | CLKout8_9_HS         | CLKout8_9_DIV [15:5]   |    |    |    |    |   |   |   |   |               | 0 | 0 | 1 | 0 | 0 |
| R5       | CLKout10_11_PD       | 0                   | CLKout11_ADLY_SEL | CLKout10_ADLY_SEL    | CLKout10_11_DDLY [27:18] |    |                      |    |    |                      |    |    |                        |    |    | 0         | CLKout10_11_HS       | CLKout10_11_DIV [15:5] |    |    |    |    |   |   |   |   |               | 0 | 0 | 1 | 0 | 1 |
| R6       | CLKout3_TYPE [31:28] |                     |                   | CLKout2_TYPE [27:24] |                          |    | CLKout1_TYPE [23:20] |    |    | CLKout0_TYPE [19:16] |    |    | CLKout2_3_ADLY [15:11] |    |    | 0         | CLKout0_1_ADLY [9:5] |                        |    | 0  | 0  | 1  | 1 | 0 |   |   |               |   |   |   |   |   |

**Table 8-2. Register Map (continued)**

| Register | 31                         | 30 | 29     | 28 | 27                         | 26                  | 25                | 24                | 23                        | 22                | 21                | 20                    | 19                         | 18                 | 17               | 16                        | 15                       | 14                       | 13      | 12              | 11             | 10                   | 9                  | 8        | 7                   | 6 | 5             | 4 | 3 | 2 | 1 | 0 |
|----------|----------------------------|----|--------|----|----------------------------|---------------------|-------------------|-------------------|---------------------------|-------------------|-------------------|-----------------------|----------------------------|--------------------|------------------|---------------------------|--------------------------|--------------------------|---------|-----------------|----------------|----------------------|--------------------|----------|---------------------|---|---------------|---|---|---|---|---|
|          | Data [26:0]                |    |        |    |                            |                     |                   |                   |                           |                   |                   |                       |                            |                    |                  |                           |                          |                          |         |                 |                |                      |                    |          |                     |   | Address [4:0] |   |   |   |   |   |
| R7       | CLKout7_TYPE [31:28]       |    |        |    | CLKout6_TYPE [27:24]       |                     |                   |                   | CLKout5_TYPE [23:20]      |                   |                   |                       | CLKout4_TYPE [19:16]       |                    |                  |                           | CLKout6_7_ADLY [15:11]   |                          |         |                 | 0              | CLKout4_5_ADLY [9:5] |                    |          |                     | 0 | 0             | 1 | 1 | 1 |   |   |
| R8       | CLKout11_TYPE [31:28]      |    |        |    | CLKout10_TYPE [27:24]      |                     |                   |                   | CLKout9_TYPE [23:20]      |                   |                   |                       | CLKout8_TYPE [19:16]       |                    |                  |                           | CLKout10_11_ADLY [15:11] |                          |         |                 | 0              | CLKout8_9_ADLY [9:5] |                    |          |                     | 0 | 1             | 0 | 0 | 0 |   |   |
| R9       | 0                          | 1  | 0      | 1  | 0                          | 1                   | 0                 | 1                 | 0                         | 1                 | 0                 | 1                     | 0                          | 1                  | 0                | 1                         | 0                        | 1                        | 0       | 1               | 0              | 1                    | 0                  | 1        | 0                   | 1 | 0             | 0 | 1 | 0 | 0 | 1 |
| R10      | OSKout1_LVPECL_AMP [31:30] |    | 0      | 1  | OSKout0_TYPE [27:24]       |                     |                   |                   | EN_OSOut1                 | EN_OSOut0         | OSKout1_MUX       | OSKout0_MUX           | PD_OSIn                    | OSKout_DIV [18:16] |                  | 0                         | 1                        | 0                        | VCO_MUX | EN_FEEDBACK_MUX | VCO_DIV [10:8] |                      | FEEDBACK_MUX [7:5] |          | 0                   | 1 | 0             | 1 | 0 |   |   |   |
| R11      | MODE [31:27]               |    |        |    | EN_SYNC                    | NO_SYNC_CLKout10_11 | NO_SYNC_CLKout8_9 | NO_SYNC_CLKout6_7 | NO_SYNC_CLKout4_5         | NO_SYNC_CLKout2_3 | NO_SYNC_CLKout0_1 | SYNC_MUX [19:18]      |                            | SYNC_QUAL          | SYNC_POL_INV     | SYNC_EN_AUTO              | SYNC_TYPE [14:12]        |                          | 0       | 0               | 0              | 0                    | 0                  | 0        | EN_PLL2_XTAL        |   | 0             | 1 | 0 | 1 | 1 |   |
| R12      | LD_MUX [31:27]             |    |        |    | LD_TYPE [26:24]            |                     |                   | SYNC_PLL2_DLD     | SYNC_PLL1_DLD             | 0                 | 0                 | 1                     | 1                          | 0                  | 0                | 0                         | 0                        | 0                        | 0       | 0               | 0              | 0                    | 0                  | EN_TRACK | HOLDOVER_MODE [7:6] |   | 1             | 0 | 1 | 1 | 0 | 0 |
| R13      | HOLDOVER_MUX [31:27]       |    |        |    | HOLDOVER_TYPE [26:24]      |                     |                   | 0                 | Status_CLKin1_MUX [22:20] |                   |                   | 0                     | Status_CLKin0_TYPE [18:16] |                    | DISABLE_DLD1_DET | Status_CLKin0_MUX [14:12] |                          | CLKin_Select_MODE [11:8] |         | CLKin_Sel_INV   | 0              | EN_CLKin1            | EN_CLKin0          | 0        | 1                   | 1 | 0             | 1 |   |   |   |   |
| R14      | LOS_TIMEOUT [31:30]        | 0  | EN_LOS | 0  | Status_CLKin1_TYPE [26:24] |                     |                   | 0                 | 0                         | CLKin1_BUF_TYPE   | CLKin0_BUF_TYPE   | DAC_HIGH_TRIP [19:14] |                            |                    |                  | 0                         | 0                        | DAC_LOW_TRIP [11:6]      |         |                 |                | EN_VTUNE_RAIL_DET    | 0                  | 1        | 1                   | 1 | 0             |   |   |   |   |   |

(1) Although the value of 0 is written here, during readback the value of READBACK\_LE will be read at this location. See Section 8.4.

Table 8-2. Register Map (continued)

| Register | 31                    | 30 | 29             | 28          | 27                   | 26                 | 25 | 24 | 23              | 22                 | 21                | 20                    | 19                      | 18 | 17                 | 16 | 15 | 14 | 13 | 12                 | 11          | 10 | 9              | 8 | 7                 | 6 | 5             | 4 | 3             | 2 | 1 | 0 |   |            |   |   |   |   |   |
|----------|-----------------------|----|----------------|-------------|----------------------|--------------------|----|----|-----------------|--------------------|-------------------|-----------------------|-------------------------|----|--------------------|----|----|----|----|--------------------|-------------|----|----------------|---|-------------------|---|---------------|---|---------------|---|---|---|---|------------|---|---|---|---|---|
|          | Data [26:0]           |    |                |             |                      |                    |    |    |                 |                    |                   |                       |                         |    |                    |    |    |    |    |                    |             |    |                |   |                   |   | Address [4:0] |   |               |   |   |   |   |            |   |   |   |   |   |
| R15      | MAN_DAC [31:22]       |    |                |             |                      |                    |    |    |                 |                    | 0                 | EN_MAN_DAC            | HOLDOVER_DLD_CNT [19:6] |    |                    |    |    |    |    |                    |             |    | FORCE_HOLDOVER | 0 | 1                 | 1 | 1             | 1 |               |   |   |   |   |            |   |   |   |   |   |
| R16      | XTAL_LVL              | 0  | 0              | 0           | 0                    | 0                  | 1  | 0  | 1               | 0                  | 1                 | 0                     | 1                       | 0  | 1                  | 0  | 0  | 0  | 0  | 0                  | 1           | 0  | 0              | 0 | 0                 | 0 | 0             | 0 | 1             | 0 | 0 | 0 | 0 |            |   |   |   |   |   |
| R24      | PLL2_C4_LF [31:28]    |    |                |             | PLL2_C3_LF [27:24]   |                    |    |    | 0               | PLL2_R4_LF [22:20] |                   |                       |                         | 0  | PLL2_R3_LF [18:16] |    |    |    | 0  | PLL1_N_DLY [14:12] |             |    |                | 0 | PLL1_R_DLY [10:8] |   |               |   | PLL1_WND_SIZE | 0 | 1 | 1 | 0 | 0          | 0 |   |   |   |   |
| R25      | DAC_CLK_DIV [31:22]   |    |                |             |                      |                    |    |    |                 |                    | 0                 | 0                     | PLL1_DLD_CNT [19:6]     |    |                    |    |    |    |    |                    |             |    | 0              | 1 | 1                 | 0 | 0             | 1 |               |   |   |   |   |            |   |   |   |   |   |
| R26      | PLL2_WND_SIZE [31:30] |    | EN_PLL2_REF_2X | PLL2_CP_POL | PLL2_CP_GAIN [27:26] |                    | 1  | 1  | 1               | 0                  | 1                 | 0                     | PLL2_DLD_CNT [19:6]     |    |                    |    |    |    |    |                    |             |    | PLL2_CP_TRI    | 1 | 1                 | 0 | 1             | 0 |               |   |   |   |   |            |   |   |   |   |   |
| R27      | 0                     | 0  | 0              | PLL1_CP_POL | PLL1_CP_GAIN         |                    | 0  | 0  | CLKin1_PreR_DIV | CLKin0_PreR_DIV    | PLL1_R [19:6]     |                       |                         |    |                    |    |    |    |    |                    | PLL1_CP_TRI | 1  | 1              | 0 | 1                 | 1 |               |   |               |   |   |   |   |            |   |   |   |   |   |
| R28      | PLL2_R                |    |                |             |                      |                    |    |    |                 |                    | PLL1_N [19:6]     |                       |                         |    |                    |    |    |    |    |                    | 0           | 1  | 1              | 1 | 0                 | 0 |               |   |               |   |   |   |   |            |   |   |   |   |   |
| R29      | 0                     | 0  | 0              | 0           | 0                    | OSCin_FREQ [26:24] |    |    |                 | PLL2_FAST_PDF      | PLL2_N_CAL [22:5] |                       |                         |    |                    |    |    |    |    |                    | 1           | 1  | 1              | 0 | 1                 |   |               |   |               |   |   |   |   |            |   |   |   |   |   |
| R30      | 0                     | 0  | 0              | 0           | 0                    | PLL2_P             |    |    |                 | 0                  | PLL2_N [22:5]     |                       |                         |    |                    |    |    |    |    |                    | 1           | 1  | 1              | 1 | 0                 |   |               |   |               |   |   |   |   |            |   |   |   |   |   |
| R31      | 0                     | 0  | 0              | 0           | 0                    | 0                  | 0  | 0  | 0               | 0                  | READBACK_LE       | READBACK_ADDR [20:16] |                         |    |                    | 0  | 0  | 0  | 0  | 0                  | 0           | 0  | 0              | 0 | 0                 | 0 | 0             | 0 | 0             | 0 | 0 | 0 | 0 | uWire_LOCK | 1 | 1 | 1 | 1 | 1 |



**Table 8-3. Readback Register Map**

| Register | RD 26            | RD 25 | RD 24 | RD 23           | RD 22           | RD 21 | RD 20 | RD 19         | RD 18         | RD 17       | RD 16 | RD 15           | RD 14 | RD 13 | RD 12 | RD 11 | RD 10 | RD 9 | RD 8 | RD 7 | RD 6 | RD 5 | RD 4 | RD 3 | RD 2     | RD 1                | RD 0       |  |
|----------|------------------|-------|-------|-----------------|-----------------|-------|-------|---------------|---------------|-------------|-------|-----------------|-------|-------|-------|-------|-------|------|------|------|------|------|------|------|----------|---------------------|------------|--|
|          | Data [26:0]      |       |       |                 |                 |       |       |               |               |             |       |                 |       |       |       |       |       |      |      |      |      |      |      |      |          |                     |            |  |
| RD R12   | LD_MUX [26:22]   |       |       |                 | LD_TYPE [21:19] |       |       | SYNC_PLL2_DLD | SYNC_PLL1_DLD | READBACK_LE | 0     | 1               | 1     | 0     | 0     | 0     | 0     | 0    | 0    | 0    | 0    | 0    | 0    | 0    | EN_TRACK | HOLDOVER_MODE [2:1] | 1          |  |
| RD R23   | RESERVED [26:24] |       |       | DAC_CNT [23:14] |                 |       |       |               |               |             |       | RESERVED [13:0] |       |       |       |       |       |      |      |      |      |      |      |      |          |                     |            |  |
| RD R31   | RESERVED [26:10] |       |       |                 |                 |       |       |               |               |             |       |                 |       |       |       |       |       |      |      |      |      |      |      |      |          |                     | uWire_LOCK |  |

## 8.5 DEFAULT DEVICE REGISTER SETTINGS AFTER POWER ON RESET

Table 8-4 illustrates the default register settings programmed in silicon for the LMK048xx after power on or asserting the reset bit. Capital X and Y represent numeric values.

**Table 8-4. Default Device Register Settings after Power On/Reset**

| Group                | Field Name          | Default Value (decimal) | Default State                        | Field Description  | Register       | Bit Location (MSB:LSB) |
|----------------------|---------------------|-------------------------|--------------------------------------|--|----------------|------------------------|
| Clock Output Control | CLKout0_1_PD        | 1                       | PD                                   | Powerdown control for analog and digital delay, divider, and both output buffers | R0             | 31                     |
|                      | CLKout2_3_PD        | 1                       | PD                                   |  | R1             |                        |
|                      | CLKout4_5_PD        | 1                       | PD                                   |  | R2             |                        |
|                      | CLKout6_7_PD        | 0                       | Normal                               |  | R3             |                        |
|                      | CLKout8_9_PD        | 0                       | Normal                               |  | R4             |                        |
|                      | CLKout10_11_PD      | 1                       | PD                                   |  | R5             |                        |
|                      | CLKout6_7_OSCin_Sel | 1                       | OSCin                                | Selects the clock source for a clock group from internal VCO or external OSCin   | R3             | 30                     |
|                      | CLKout8_9_OSCin_Sel | 0                       | VCO                                  |  | R4             | 30                     |
|                      | CLKoutX_ADLY_SEL    | 0                       | None                                 | Add analog delay for clock output  | R0 to R5       | 28, 29                 |
|                      | CLKoutX_Y_DDLY      | 0                       | 5                                    | Digital delay value  | R0 to R5       | 27:18 [10]             |
|                      | RESET               | 0                       | Not in reset                         | Performs power on reset for device   | R0             | 17                     |
|                      | POWERDOWN           | 0                       | Disabled (device is active)          | Device power down control  | R1             | 17                     |
|                      | CLKoutX_Y_HS        | 0                       | No shift                             | Half shift for digital delay   | R0 to R5       | 16                     |
|                      | CLKout0_1_DIV       | 25                      | Divide-by-25                         | Divide for clock outputs   | R0             | 15:5 [11]              |
|                      | CLKout2_3_DIV       | 25                      | Divide-by-25                         |  | R1             |                        |
|                      | CLKout4_5_DIV       | 25                      | Divide-by-25                         |  | R2             |                        |
|                      | CLKout6_7_DIV       | 1                       | Divide-by-1                          |  | R3             |                        |
|                      | CLKout8_9_DIV       | 25                      | Divide-by-25                         |  | R4             |                        |
|                      | CLKout10_11_DIV     | 25                      | Divide-by-25                         |  | R5             |                        |
|                      | CLKout3_TYPE        | 0                       | Powerdown                            | Individual clock output format. Select from LVDS/LVPECL/LVCMOS.                  | R6             | 31:28 [4]              |
|                      | CLKout7_TYPE        | 0                       | Powerdown                            |  | R7             |                        |
|                      | CLKout11_TYPE       | 0                       | Powerdown                            |  | R8             |                        |
|                      | CLKout2_TYPE        | 0                       | Powerdown                            |  | R6             | 27:24 [4]              |
| CLKout6_TYPE         | 8                   | LVCMOS (Norm/Norm)      | R7                                   |  |                |                        |
| CLKout10_TYPE        | 0                   | Powerdown               | R8                                   |  | 23:20 [4]      |                        |
| CLKout1_TYPE         | 0                   | Powerdown               | R6                                   |  |                |                        |
| CLKout5_TYPE         | 0                   | Powerdown               | R7                                   |  |                |                        |
| CLKout9_TYPE         | 0                   | Powerdown               | R8                                   |  |                |                        |
| CLKout0_TYPE         | 0                   | Powerdown               | R6                                   |  | 19:16 [4]      |                        |
| CLKout4_TYPE         | 0                   | Powerdown               | R7                                   |  |                |                        |
| CLKout8_TYPE         | 1                   | LVDS                    | R8                                   |  |                |                        |
| CLKoutX_Y_ADLY       | 0                   | No delay                | Analog delay setting for clock group | R6 to R8   | 15:11, 9:5 [5] |                        |
| Osc Buffer Control   | OSCCout1_LVPECL_AMP | 2                       | 1600 mVpp LVPECL                     | Set LVPECL amplitude   | R10            | 31:30 [2]              |
|                      | OSCCout0_TYPE       | 1                       | LVDS                                 | OSCCout0 default clock output  | R10            | 27:24 [4]              |
|                      | EN_OSCout1          | 0                       | Disabled                             | Disable OSCout1 output buffer  | R10            | 23                     |
|                      | EN_OSCout0          | 1                       | Enabled                              | Enable OSCout0 output buffer   | R10            | 22                     |
|                      | OSCCout1_MUX        | 0                       | Bypass Divider                       | Select OSCout divider for OSCout1 or bypass                                      | R10            | 21                     |
|                      | OSCCout0_MUX        | 0                       | Bypass Divider                       | Select OSCout divider for OSCout0 or bypass                                      | R10            | 20                     |
|                      | PD_OSCin            | 0                       | OSCin powered                        | Allows OSCin to be powered down. For use in clock distribution mode.             | R10            | 19                     |
|                      | OSCCout_DIV         | 0                       | Divide-by-8                          | OSCCout divider value  | R10            | 18:16 [3]              |

**Table 8-4. Default Device Register Settings after Power On/Reset (continued)**

| Group                 | Field Name          | Default Value (decimal) | Default State                                       | Field Description   | Register  | Bit Location (MSB:LSB) |
|-----------------------|---------------------|-------------------------|---|---|-----------|------------------------|
| Mode                  | VCO_MUX             | 0                       | VCO   | Select VCO or VCO Divider output  | R10       | 12                     |
|                       | EN_FEEDBACK_MUX     | 0                       | Disabled  | Feedback MUX is powered down.   | R10       | 11                     |
|                       | VCO_DIV             | 2                       | Divide-by-2   | VCO Divide value  | R10       | 10:8 [3]               |
|                       | FEEDBACK_MUX        | 0                       | CLKout0   | Selects CLKout to feedback into the PLL1 N divider                      | R10       | 7:5 [3]                |
|                       | MODE                | 0                       | Internal VCO  | Device mode   | R11       | 31:27 [5]              |
| Clock Synchronization | EN_SYNC             | 1                       | Enabled   | Enables synchronization circuitry.                                      | R11       | 26                     |
|                       | NO_SYNC_CLKout10_11 | 0                       | Will sync   | Disable individual clock groups from becoming synchronized.             | R11       | 25                     |
|                       | NO_SYNC_CLKout8_9   | 1                       | Will not sync                                       |   | R11       | 24                     |
|                       | NO_SYNC_CLKout6_7   | 1                       | Will not sync                                       |   | R11       | 23                     |
|                       | NO_SYNC_CLKout4_5   | 0                       | Will sync   |   | R11       | 22                     |
|                       | NO_SYNC_CLKout2_3   | 0                       | Will sync   |   | R11       | 21                     |
|                       | NO_SYNC_CLKout0_1   | 0                       | Will sync   |   | R11       | 20                     |
|                       | SYNC_MUX            | 0                       | Logic Low   | Mux controlling SYNC pin when set to output                             | R11       | 19:18 [2]              |
|                       | SYNC_QUAL           | 0                       | Not qualified                                       | Allows SYNC operations to be qualified by a clock output.               | R11       | 17                     |
|                       | SYNC_POL_INV        | 1                       | Logic Low   | Sets the polarity of the SYNC pin when input                            | R11       | 16                     |
|                       | SYNC_EN_AUTO        | 0                       | Manual  | SYNC is not started by programming a register R0 to R5.                 | R11       | 15                     |
| SYNC_TYPE             | 1                   | Input /w Pull-up        | SYNC IO pin type                                    | R11   | 14:12 [3] |                        |
| Other Mode Control    | EN_PLL2_XTAL        | 0                       | Disabled  | Enable Crystal oscillator for OSCin                                     | R11       | 5                      |
|                       | LD_MUX              | 3                       | PLL1 & 2 DLD  | Lock detect mux selection when output                                   | R12       | 31:27 [5]              |
|                       | LD_TYPE             | 3                       | Output (Push-Pull)                                  | LD IO pin type  | R12       | 26:24 [3]              |
|                       | SYNC_PLL2_DLD       | 0                       | Normal  | Force synchronization mode until PLL2 locks                             | R12       | 23                     |
|                       | SYNC_PLL1_DLD       | 0                       | Normal  | Force synchronization mode until PLL1 locks                             | R12       | 22                     |
|                       | EN_TRACK            | 1                       | Enable Tracking                                     | DAC tracking of the PLL1 tuning voltage                                 | R12       | 8                      |
|                       | HOLDOVER_MODE       | 2                       | Enable Holdover                                     | Causes holdover to activate when lock is lost                           | R12       | 7:6 [2]                |
|                       | HOLDOVER_MUX        | 7                       | uWire Readback                                      | Holdover mux selection  | R13       | 31:27 [5]              |
|                       | HOLDOVER_TYPE       | 3                       | Output (Push-Pull)                                  | HOLDOVER IO pin type  | R13       | 26:24 [3]              |
|                       | Status_CLKin1_MUX   | 0                       | Logic Low   | Status_CLKin1 pin MUX selection   | R13       | 22:20 [3]              |
|                       | Status_CLKin0_TYPE  | 2                       | Input /w Pull-down                                  | Status_CLKin0 IO pin type   | R13       | 18:16 [3]              |
|                       | DISABLE_DLD1_DET    | 0                       | Not Disabled  | Disables PLL1 DLD falling edge from causing HOLDOVER mode to be entered | R13       | 15                     |
|                       | Status_CLKin0_MUX   | 0                       | Logic Low   | Status_CLKin0 pin MUX selection   | R13       | 14:12 [3]              |
| CLKin_SELECT_MODE     | 3                   | Manual Select           | Mode to use in determining reference CLKin for PLL1 | R13   | 11:9 [3]  |                        |
| CLKin_Sel_INV         | 0                   | Active High             | Invert Status 0 and 1 pin polarity for input        | R13   | 8         |                        |
| CLKin Control         | EN_CLKin1           | 1                       | Usable  | Set CLKin1 to be usable   | R13       | 6                      |
|                       | EN_CLKin0           | 1                       | Usable  | Set CLKin0 to be usable   | R13       | 5                      |
|                       | LOS_TIMEOUT         | 0                       | 1200 ns, 420 kHz                                    | Time until no activity on CLKin asserts LOS                             | R14       | 31:30 [2]              |
|                       | EN_LOS              | 1                       | Enabled   | Loss of Signal Detect at CLKin  | R14       | 28                     |
|                       | Status_CLKin1_TYPE  | 2                       | Input /w Pull-down                                  | Status_CLKin1 pin IO pin type   | R14       | 26:24 [3]              |
|                       | CLKin1_BUF_TYPE     | 0                       | Bipolar   | CLKin1 Buffer Type  | R14       | 21                     |
|                       | CLKin0_BUF_TYPE     | 0                       | Bipolar   | CLKin0 Buffer Type  | R14       | 20                     |

**Table 8-4. Default Device Register Settings after Power On/Reset (continued)**

| Group       | Field Name        | Default Value (decimal) | Default State               | Field Description  | Register                                  | Bit Location (MSB:LSB) |           |
|-------------|-------------------|-------------------------|-----------------------------|--|---|------------------------|-----------|
| DAC Control | DAC_HIGH_TRIP     | 0                       | ~50 mV from V <sub>CC</sub> | Voltage from V <sub>CC</sub> at which holdover mode is entered if EN_VTUNE_RAIL_DAC is enabled.                        | R14                                       | 19:14 [6]              |           |
|             | DAC_LOW_TRIP      | 0                       | ~50 mV from GND             | Voltage from GND at which holdover mode is entered if EN_VTUNE_RAIL_DAC is enabled.                                    | R14                                       | 11:6 [6]               |           |
|             | EN_VTUNE_RAIL_DET | 0                       | Disabled                    | Enable PLL1 unlock state when DAC trip points are achieved   | R14                                       | 5                      |           |
|             | MAN_DAC           | 512                     | 3 V / 2                     | Writing to this register will set the value for DAC when in manual override. Readback from this register is DAC value. | R15                                       | 31:22 [10]             |           |
|             | EN_MAN_DAC        | 0                       | Disabled                    | Set manual DAC override  | R15                                       | 20                     |           |
|             | HOLDOVER_DLD_CNT  | 512                     | 512 counts                  | Lock must be valid n many clocks of PLL1 PDF before holdover mode is exited.   | R15                                       | 19:6 [14]              |           |
|             | FORCE_HOLDOVER    | 0                       | Holdover not forced         | Forces holdover mode.  | R15                                       | 5                      |           |
|             | XTAL_LVL          | 0                       | 1.65 V <sub>pp</sub>        | Sets drive power level of Crystal  | R16                                       | 31:30 [2]              |           |
| PLL Control | PLL2_C4_LF        | 0                       | 10 pF                       | PLL2 integrated capacitor C4 value   | R24                                       | 31:28 [4]              |           |
|             | PLL2_C3_LF        | 0                       | 10 pF                       | PLL2 integrated capacitor C3 value   | R24                                       | 27:24 [4]              |           |
|             | PLL2_R4_LF        | 0                       | 200 Ω                       | PLL2 integrated resistor R4 value  | R24                                       | 22:20 [3]              |           |
|             | PLL2_R3_LF        | 0                       | 200 Ω                       | PLL2 integrated resistor R3 value  | R24                                       | 18:16 [3]              |           |
|             | PLL1_N_DLY        | 0                       | No delay                    | Delay in PLL1 feedback path to decrease lag from input to output   | R24                                       | 14:12 [3]              |           |
|             | PLL1_R_DLY        | 0                       | No delay                    | Delay in PLL1 reference path to increase lag from input to output  | R24                                       | 10:8 [3]               |           |
|             | PLL1_WND_SIZE     | 3                       | 40 ns                       | Window size used for digital lock detect for PLL1  | R24                                       | 7:6 [2]                |           |
|             | DAC_CLK_DIV       | 4                       | Divide-by-4                 | DAC update clock divisor. Divides PLL1 phase detector frequency.   | R25                                       | 31:22 [10]             |           |
|             | PLL1_DLD_CNT      | 1024                    | 1024 cycles                 | Lock must be valid n many cycles before LD is asserted   | R25                                       | 19:6 [14]              |           |
|             | PLL2_WND_SIZE     | 0                       | Reserved <sup>(1)</sup>     | Window size used for digital lock detect for PLL2  | R26                                       | 31:30 [2]              |           |
|             | EN_PLL2_REF_2X    | 0                       | Disabled, 1x                | Doubles reference frequency of PLL2.   | R26                                       | 29                     |           |
|             | PLL2_CP_POL       | 0                       | Negative                    | Polarity of PLL2 Charge Pump   | R26                                       | 28                     |           |
|             | PLL2_CP_GAIN      | 3                       | 3.2 mA                      | PLL2 Charge Pump Gain  | R26                                       | 27:26 [2]              |           |
|             | PLL2_DLD_CNT      | 8192                    | 8192 Counts                 | Number of PDF cycles which phase error must be within DLD window before LD state is asserted.                          | R26                                       | 19:6 [14]              |           |
|             | PLL2_CP_TRI       | 0                       | Active                      | PLL2 Charge Pump Active  | R26                                       | 5                      |           |
|             | PLL1_CP_POL       | 1                       | Positive                    | Polarity of PLL1 Charge Pump   | R27                                       | 28                     |           |
|             | PLL1_CP_GAIN      | 0                       | 100 uA                      | PLL1 Charge Pump Gain  | R27                                       | 27:26 [2]              |           |
|             | CLKin1_PreR_DIV   | 0                       | Divide-by-1                 | CLKin1 Pre-R divide value (1, 2, 4, or 8)  | R27                                       | 23:22 [2]              |           |
|             | CLKin0_PreR_DIV   | 0                       | Divide-by-1                 | CLKin0 Pre-R divide value (1, 2, 4, or 8)  | R27                                       | 21:20 [2]              |           |
|             | PLL1_R            | 96                      | Divide-by-96                | PLL1 R Divider (1 to 16383)  | R27                                       | 19:6 [14]              |           |
|             | PLL1_CP_TRI       | 0                       | Active                      | PLL1 Charge Pump Active  | R27                                       | 5                      |           |
|             | PLL2_R            | 4                       | Divide-by-4                 | PLL2 R Divider (1 to 4095)   | R28                                       | 31:20 [12]             |           |
|             | PLL1_N            | 192                     | Divide-by-192               | PLL1 N Divider (1 to 16383)  | R28                                       | 19:6 [14]              |           |
|             | OSCin_FREQ        | 7                       | 448 to 511 MHz              | OSCin frequency range  | R29                                       | 26:24 [3]              |           |
|             | PLL2_FAST_PDF     | 1                       | PLL2 PDF > 100 MHz          | When set, PLL2 PDF of greater than 100 MHz may be used   | R29                                       | 23                     |           |
|             | PLL2_N_CAL        | 48                      | Divide-by-48                | Must be programmed to PLL2_N value.  | R29                                       | 22:5 [18]              |           |
|             | PLL2_P            | 2                       | Divide-by-2                 | PLL2 N Divider Prescaler (2 to 8)  | R30                                       | 26:24 [3]              |           |
|             | PLL2_N            | 48                      | Divide-by-48                | PLL2 N Divider (1 to 262143)   | R30                                       | 22:5 [18]              |           |
|             |                   | READBACK_LE             | 0                           | LEuWire Low for Readback   | State LEuWire pin must be in for readback | R31                    | 21        |
|             |                   | READBACK_ADDR           | 31                          | Register 31  | Register to read back                     | R31                    | 20:16 [5] |
| uWire_LOCK  |                   | 0                       | Writable                    | The values of registers R0 to R30 are lockable   | R31                                       | 5                      |           |

(1) This register must be reprogrammed to a value of 2 (3.7 ns) during user programming.

## 8.6 REGISTER R0 TO R5

Registers R0 through R5 control the 12 clock outputs CLKout0 to CLKout11. Register R0 controls CLKout0 and CLKout1, Register R1 controls CLKout2 and CLKout3, and so on. All functions of the bits in these six registers are identical except the different registers control different clock outputs. The X and Y in CLKoutX\_Y\_PD, CLKoutX\_ADLY\_SEL, CLKoutY\_ADLY\_SEL, CLKoutX\_Y\_DDLY, CLKoutX\_Y\_HS, CLKoutX\_Y\_DIV denote the actual clock output which may be from 0 to 11 where X is even and Y is odd. Two clock outputs CLKoutX and CLKoutY form a clock output group and are often run together in bit names as CLKoutX\_Y.

The RESET bit is only in register R0.

The POWERDOWN bit is only in register R1.

The CLKoutX\_Y\_OSCin\_Sel bit is only in registers R3 and R4.

### 8.6.1 CLKoutX\_Y\_PD, Powerdown CLKoutX\_Y Output Path

This bit powers down the clock group as specified by CLKoutX and CLKoutY. This includes the divider, digital delay, analog delay, and output buffers.

**Table 8-5. CLKoutX\_Y\_PD**

| R0-R5[31] | State                  |
|-----------|------------------------|
| 0         | Power up clock group   |
| 1         | Power down clock group |

### 8.6.2 CLKoutX\_Y\_OSCin\_Sel, Clock group source

This bit sets the source for the clock output group CLKoutX\_Y. The selected source will be either from a VCO via Mode Mux1 or from the OSCin buffer.

This bit is valid only for registers R3 and R4, clock groups CLKout6\_7 and CLKout8\_9 respectively. All other clock output groups are driven by a VCO via Mode Mux1.

**Table 8-6. CLKoutX\_Y\_OSCin\_Sel**

| R3-R4[30] | Clock group source |
|-----------|--------------------|
| 0         | VCO                |
| 1         | OSCin              |

### 8.6.3 CLKoutY\_ADLY\_SEL[29], CLKoutX\_ADLY\_SEL[28], Select Analog Delay

These bits individually select the analog delay block (Section 8.7.2) for use with CLKoutX or CLKoutY. It is not required for both outputs of a clock output group to use analog delay, but if both outputs do select the analog delay block, then the analog delay will be the same for each output, CLKoutX and CLKoutY. When neither clock output uses analog delay, the analog delay block is powered down. Analog delay may not operate at frequencies above the minimum-ensured maximum output frequency of 1536 MHz.

**Table 8-7. CLKoutY\_ADLY\_SEL[29], CLKoutX\_ADLY\_SEL[28]**

| R0-R5[29] | R0-R5[28] | State                        |
|-----------|-----------|------------------------------|
| 0         | 0         | Analog delay powered down    |
| 0         | 1         | Analog delay on even CLKoutX |
| 1         | 0         | Analog delay on odd CLKoutY  |
| 1         | 1         | Analog delay on both CLKouts |

### 8.6.4 CLKoutX\_Y\_DDLY, Clock Channel Digital Delay

CLKoutX\_Y\_DDLY and CLKoutX\_Y\_HS sets the digital delay used for CLKoutX and CLKoutY. This value only takes effect during a SYNC event and if the NO\_SYNC\_CLKoutX\_Y bit is cleared for this clock group. See Section 7.9.2.

Programming CLKoutX\_Y\_DDLY can require special attention. See section Section 8.1 for more details.

Using a CLKoutX\_Y\_DDLY value of 13 or greater will cause the clock group to operate in extended mode regardless of the clock group's divide value or the half step value.

One clock cycle is equal to the period of the clock distribution path. The period of the clock distribution path is equal to VCO Divider value divided by the frequency of the VCO. If the VCO divider is disabled or an external VCO is used, the VCO divide value is treated as 1.

$$t_{\text{clock distribution path}} = \text{VCO divide value} / f_{\text{VCO}}$$

**Table 8-8. CLKoutX\_Y\_DDLY, 10 bits**

| R0-R5[27:18] | Delay            | Power Mode  |
|--------------|------------------|-------------|
| 0 (0x00)     | 5 clock cycles   | Normal Mode |
| 1 (0x01)     | 5 clock cycles   |             |
| 2 (0x02)     | 5 clock cycles   |             |
| 3 (0x03)     | 5 clock cycles   |             |
| 4 (0x04)     | 5 clock cycles   |             |
| 5 (0x05)     | 5 clock cycles   |             |
| 6 (0x06)     | 6 clock cycles   |             |
| 7 (0x07)     | 7 clock cycles   |             |
| ...          | ...              |             |
| 12 (0x0C)    | 12 clock cycles  |             |
| 13 (0x0D)    | 13 clock cycles  |             |
| ...          | ...              |             |
| 520 (0x208)  | 520 clock cycles |             |
| 521 (0x209)  | 521 clock cycles |             |
| 522 (0x20A)  | 522 clock cycles |             |

### 8.6.5 RESET

The RESET bit is located in register R0 only. Setting this bit will cause the silicon default values to be loaded. When programming register R0 with the RESET bit set, all other programmed values are ignored. After resetting the device, the register R0 must be programmed again (with RESET = 0) to set non-default values in register R0.

The reset occurs on the falling edge of the LEuWire pin which loaded R0 with RESET = 1.

The RESET bit is automatically cleared upon writing any other register. For instance, when R0 is written to again with default values.

**Table 8-9. RESET**

| R0[17] | State                         |
|--------|-------------------------------|
| 0      | Normal operation              |
| 1      | Reset (automatically cleared) |

### 8.6.6 POWERDOWN

The POWERDOWN bit is located in register R1 only. Setting the bit causes the device to enter powerdown mode. Normal operation is resumed by clearing this bit with MICROWIRE.

**Table 8-10. POWERDOWN**

| R1[17] | State            |
|--------|------------------|
| 0      | Normal operation |
| 1      | Powerdown        |

### 8.6.7 CLKoutX\_Y\_HS, Digital Delay Half Shift

This bit subtracts a half clock cycle of the clock distribution path period to the digital delay of CLKoutX and CLKoutY. CLKoutX\_Y\_HS is used together with CLKoutX\_Y\_DDLY to set the digital delay value.

When changing CLKoutX\_Y\_HS, the digital delay immediately takes effect without a SYNC event.

**Table 8-11. CLKoutX\_Y\_HS**

| R0-R5[16] | State  |
|-----------|--|
| 0         | Normal   |
| 1         | Subtract half of a clock distribution path period from the total digital delay |

### 8.6.8 CLKoutX\_Y\_DIV, Clock Output Divide

CLKoutX\_Y\_DIV sets the divide value for the clock group. The divide may be even or odd. Both even and odd divides output a 50% duty cycle clock.

Using a divide value of 26 or greater will cause the clock group to operate in extended mode regardless of the clock group's digital delay value.

Programming CLKoutX\_Y\_DIV can require special attention. See section [Section 8.1](#) for more details.

**Table 8-12. CLKoutX\_Y\_DIV, 11 bits**

| R0-R5[15:5]  | Divide Value     | Power Mode    |
|--------------|------------------|---------------|
| 0 (0x00)     | Reserved         | Normal Mode   |
| 1 (0x01)     | 1 <sup>(1)</sup> |               |
| 2 (0x02)     | 2 <sup>(2)</sup> |               |
| 3 (0x03)     | 3                |               |
| 4 (0x04)     | 4 <sup>(2)</sup> |               |
| 5 (0x05)     | 5 <sup>(2)</sup> |               |
| 6 (0x06)     | 6                |               |
| ...          | ...              |               |
| 24 (0x18)    | 24               |               |
| 25 (0x19)    | 25               |               |
| 26 (0x1A)    | 26               | Extended Mode |
| 27 (0x1B)    | 27               |               |
| ...          | ...              |               |
| 1044 (0x414) | 1044             |               |
| 1045 (0x415) | 1045             |               |

- (1) CLKoutX\_Y\_HS must = 0 for divide by 1.
- (2) After programming PLL2\_N value, a SYNC must occur on channels using this divide value. Programming PLL2\_N does generate a SYNC event automatically which satisfies this requirement, but NO\_SYNC\_CLKoutX\_Y must be set to 0 for these clock groups.



## 8.7 REGISTERS R6 TO R8

Registers R6 to R8 set the clock output types and analog delays.

### 8.7.1 CLKoutX\_TYPE

The clock output types of the LMK048xx are individually programmable. The CLKoutX\_TYPE registers set the output type of an individual clock output to LVDS, LVPECL, LVCMOS, or powers down the output buffer. Note that LVPECL supports four different amplitude levels and LVCMOS supports single LVCMOS outputs, inverted, and normal polarity of each output pin for maximum flexibility.

The programming addresses table shows at what register and address the specified clock output CLKoutX\_TYPE register is located.

The CLKoutX\_TYPE table shows the programming definition for these registers.

**Table 8-13. CLKoutX\_TYPE Programming Addresses**

| CLKoutX  | Programming Address |
|----------|---------------------|
| CLKout0  | R6[19:16]           |
| CLKout1  | R6[23:20]           |
| CLKout2  | R6[27:24]           |
| CLKout3  | R6[31:28]           |
| CLKout4  | R7[19:16]           |
| CLKout5  | R7[23:20]           |
| CLKout6  | R7[27:24]           |
| CLKout7  | R7[31:28]           |
| CLKout8  | R8[19:16]           |
| CLKout9  | R8[23:20]           |
| CLKout10 | R8[27:24]           |
| CLKout11 | R8[31:28]           |

**Table 8-14. CLKoutX\_TYPE, 4 bits**

| R6-R8[31:28, 27:24, 23:20] | Definition         |
|----------------------------|--------------------|
| 0 (0x00)                   | Power down         |
| 1 (0x01)                   | LVDS               |
| 2 (0x02)                   | LVPECL (700 mVpp)  |
| 3 (0x03)                   | LVPECL (1200 mVpp) |
| 4 (0x04)                   | LVPECL (1600 mVpp) |
| 5 (0x05)                   | LVPECL (2000 mVpp) |
| 6 (0x06)                   | LVCMOS (Norm/Inv)  |
| 7 (0x07)                   | LVCMOS (Inv/Norm)  |
| 8 (0x08)                   | LVCMOS (Norm/Norm) |
| 9 (0x09)                   | LVCMOS (Inv/Inv)   |
| 10 (0x0A)                  | LVCMOS (Low/Norm)  |
| 11 (0x0A)                  | LVCMOS (Low/Inv)   |
| 12 (0x0C)                  | LVCMOS (Norm/Low)  |
| 13 (0x0D)                  | LVCMOS (Inv/Low)   |
| 14 (0x0E)                  | LVCMOS (Low/Low)   |

### 8.7.2 CLKoutX\_Y\_ADLY

These registers control the analog delay of the clock group CLKoutX\_Y. Adding analog delay to the output will increase the noise floor of the output. For this analog delay to be active for a clock output, it must be selected with CLKout(X or Y)\_ADL\_SEL. If neither clock output in a clock group selects the analog delay, then the analog delay block is powered down. Analog delay may not operate at frequencies above the minimum-ensured maximum output frequency of 1536 MHz.

In addition to the programmed delay, a fixed 500 ps of delay will be added by engaging the delay block.

The programming addresses table shows at what register and address the specified clock output CLKoutX\_Y\_ADLY register is located.

The CLKoutX\_Y\_ADLY table shows the programming definition for these registers.

**Table 8-15. CLKoutX\_Y\_ADLY Programming Addresses**

| CLKoutX_Y_ADLY   | Programming Address |
|------------------|---------------------|
| CLKout0_1_ADLY   | R6[9:5]             |
| CLKout2_3_ADLY   | R6[15:11]           |
| CLKout4_5_ADLY   | R7[9:5]             |
| CLKout6_7_ADLY   | R7[15:11]           |
| CLKout8_9_ADLY   | R8[9:5]             |
| CLKout10_11_ADLY | R8[15:11]           |

**Table 8-16. CLKoutX\_Y\_ADLY, 5 bits**

| R6-R8[15:11, 9:5] | Definition        |
|-------------------|-------------------|
| 0 (0x00)          | 500 ps + No delay |
| 1 (0x01)          | 500 ps + 25 ps    |
| 2 (0x02)          | 500 ps + 50 ps    |
| 3 (0x03)          | 500 ps + 75 ps    |
| 4 (0x04)          | 500 ps + 100 ps   |
| 5 (0x05)          | 500 ps + 125 ps   |
| 6 (0x06)          | 500 ps + 150 ps   |
| 7 (0x07)          | 500 ps + 175 ps   |
| 8 (0x08)          | 500 ps + 200 ps   |
| 9 (0x09)          | 500 ps + 225 ps   |
| 10 (0x0A)         | 500 ps + 250 ps   |
| 11 (0x0B)         | 500 ps + 275 ps   |
| 12 (0x0C)         | 500 ps + 300 ps   |
| 13 (0x0D)         | 500 ps + 325 ps   |
| 14 (0x0E)         | 500 ps + 350 ps   |
| 15 (0x0F)         | 500 ps + 375 ps   |
| 16 (0x10)         | 500 ps + 400 ps   |
| 17 (0x11)         | 500 ps + 425 ps   |
| 18 (0x12)         | 500 ps + 450 ps   |
| 19 (0x13)         | 500 ps + 475 ps   |
| 20 (0x14)         | 500 ps + 500 ps   |
| 21 (0x15)         | 500 ps + 525 ps   |
| 22 (0x16)         | 500 ps + 550 ps   |
| 23 (0x17)         | 500 ps + 575 ps   |

## 8.8 REGISTER R10

### 8.8.1 OSCout1\_LVPECL\_AMP, LVPECL Output Amplitude Control

The OSCout1 clock output can only be used as an LVPECL output type. OSCout1\_LVPECL\_AMP sets the LVPECL output amplitude of the OSCout1 clock output.

**Table 8-17. OSCout1\_LVPECL\_AMP, 2 bits**

| R10[31:30] | Output Format      |
|------------|--------------------|
| 0 (0x00)   | LVPECL (700 mVpp)  |
| 1 (0x01)   | LVPECL (1200 mVpp) |
| 2 (0x02)   | LVPECL (1600 mVpp) |
| 3 (0x03)   | LVPECL (2000 mVpp) |

### 8.8.2 OSCout0\_TYPE

The OSCout0 clock output has a programmable output type. The OSCout0\_TYPE register sets the output type to LVDS, LVPECL, LVCMOS, or powers down the output buffer. Note that LVPECL supports four different amplitude levels and LVCMOS supports dual and single LVCMOS outputs with inverted, and normal polarity of each output pin for maximum flexibility.

To turn on the output, the OSCout0\_TYPE must be set to a non-power down setting and enabled with [Section 8.8.3](#).

**Table 8-18. OSCout0\_TYPE, 4 bits**

| R10[27:24] | Definition         |
|------------|--------------------|
| 0 (0x00)   | Powerdown          |
| 1 (0x01)   | LVDS               |
| 2 (0x02)   | LVPECL (700 mVpp)  |
| 3 (0x03)   | LVPECL (1200 mVpp) |
| 4 (0x04)   | LVPECL (1600 mVpp) |
| 5 (0x05)   | LVPECL (2000 mVpp) |
| 6 (0x06)   | LVCMOS (Norm/Inv)  |
| 7 (0x07)   | LVCMOS (Inv/Norm)  |
| 8 (0x08)   | LVCMOS (Norm/Norm) |
| 9 (0x09)   | LVCMOS (Inv/Inv)   |
| 10 (0x0A)  | LVCMOS (Low/Norm)  |
| 11 (0x0B)  | LVCMOS (Low/Inv)   |
| 12 (0x0C)  | LVCMOS (Norm/Low)  |
| 13 (0x0D)  | LVCMOS (Inv/Low)   |
| 14 (0x0E)  | LVCMOS (Low/Low)   |

### 8.8.3 EN\_OSCoutX, OSCout Output Enable

EN\_OSCoutX is used to enable an oscillator buffered output.

**Table 8-19. EN\_OSCout1**

| R10[23] | Output State     |
|---------|------------------|
| 0       | OSCout1 Disabled |
| 1       | OSCout1 Enabled  |

**Table 8-20. EN\_OSCout0**

| R10[22] | Output State     |
|---------|------------------|
| 0       | OSCout0 Disabled |
| 1       | OSCout0 Enabled  |

OSCout0 note: In addition to enabling the output with EN\_OSCout0. The OSCout0\_TYPE must be programmed to a non-power down value for the output buffer to power up.

### 8.8.4 OSCoutX\_MUX, Clock Output Mux

Sets OSCoutX buffer to output a divided or bypassed OSCin signal. The divisor is set by [Section 8.8.6](#).

**Table 8-21. OSCout1\_MUX**

| R10[21] | Mux Output     |
|---------|----------------|
| 0       | Bypass divider |
| 1       | Divided        |

**Table 8-22. OSCout0\_MUX**

| R10[20] | Mux Output     |
|---------|----------------|
| 0       | Bypass divider |
| 1       | Divided        |

### 8.8.5 PD\_OSCin, OSCin Powerdown Control

Except in clock distribution mode, the OSCin buffer must always be powered up.

In clock distribution mode, the OSCin buffer must be powered down if not used.

**Table 8-23. PD\_OSCin**

| R10[19] | OSCin Buffer     |
|---------|------------------|
| 0       | Normal Operation |
| 1       | Powerdown        |

### 8.8.6 OSCout\_DIV, Oscillator Output Divide

The OSCout divider can be programmed from 2 to 8. Divide by 1 is achieved by bypassing the divider with [Section 8.8.4](#).

Note that OSCout\_DIV will be in the PLL1 N feedback path if OSCout0\_MUX selects divided as an output. When OSCout\_DIV is in the PLL1 N feedback path, the OSCout\_DIV divide value must be accounted for when programming PLL1 N.

See [Section 9.2](#) for more information on programming PLL1 to lock.

**Table 8-24. OSCout\_DIV, 3 bits**

| R10[18:16] | Divide |
|------------|--------|
| 0 (0x00)   | 8      |
| 1 (0x01)   | 2      |
| 2 (0x02)   | 2      |
| 3 (0x03)   | 3      |
| 4 (0x04)   | 4      |
| 5 (0x05)   | 5      |
| 6 (0x06)   | 6      |
| 7 (0x07)   | 7      |

### 8.8.7 VCO\_MUX

When the internal VCO is used, the VCO divider can be selected to divide the VCO output frequency to reduce the frequency on the clock distribution path. It is recommended to use the VCO directly unless:

- Very low output frequencies are required.
- If using the VCO divider results in three or more clock output divider/delays changing from extended to normal power mode, a small power savings may be achieved by using the VCO divider.

A consequence of using the VCO divider is a small degradation in phase noise.

**Table 8-25. VCO\_MUX**

| R10[12] | Divide               |
|---------|----------------------|
| 0       | VCO selected         |
| 1       | VCO divider selected |

### 8.8.8 EN\_FEEDBACK\_MUX

When using 0-delay or dynamic digital delay (SYNC\_QUAL = 1), EN\_FEEDBACK\_MUX must be set to 1 to power up the feedback mux.

**Table 8-26. EN\_FEEDBACK\_MUX**

| R10[11] | Divide                    |
|---------|---------------------------|
| 0       | Feedback mux powered down |
| 1       | Feedback mux enabled      |

### 8.8.9 VCO\_DIV, VCO Divider

Divide value of the VCO Divider.

See [Section 9.2](#) for more information on programming PLL2 to lock.

**Table 8-27. VCO\_DIV, 3 bits**

| R10[10:8] | Divide |
|-----------|--------|
| 0 (0x00)  | 8      |
| 1 (0x01)  | 2      |
| 2 (0x02)  | 2      |
| 3 (0x03)  | 3      |
| 4 (0x04)  | 4      |
| 5 (0x05)  | 5      |
| 6 (0x06)  | 6      |
| 7 (0x07)  | 7      |

### 8.8.10 FEEDBACK\_MUX

When in 0-delay mode, the feedback mux selects the clock output to be fed back into the PLL1 N Divider.

**Table 8-28. FEEDBACK\_MUX, 3 bits**

| R10[7:5] | Divide           |
|----------|------------------|
| 0 (0x00) | CLKout0          |
| 1 (0x01) | CLKout2          |
| 2 (0x02) | CLKout4          |
| 3 (0x03) | CLKout6          |
| 4 (0x04) | CLKout8          |
| 5 (0x05) | CLKout10         |
| 6 (0x06) | FBCLKin/FBCLKin* |

## 8.9 REGISTER R11

### 8.9.1 *MODE: Device Mode*

MODE determines how the LMK04800 operates from a high level. Different blocks of the device can be powered up and down for specific application requirements from a dual loop architecture to clock distribution.

The LMK04800 can operate in:

- Dual PLL mode with the internal VCO or an external VCO.
- Single PLL mode uses PLL2 and powers down PLL1. OSCin is used for PLL reference input.
- Clock Distribution mode allows use of CLKin1 to distribute to clock outputs CLKout0 through CLKout11, and OSCin to distribute to OSCout0, OSCout1, and optionally CLKout6 through CLKout9.

For the PLL modes, 0-delay can be used have deterministic phase with the input clock.

For the PLL modes it is also possible to use an external VCO.

**Table 8-29. MODE, 5 bits**

| R11[31:27] | Value                                    |
|------------|--|
| 0 (0x00)   | Dual PLL, Internal VCO                   |
| 1 (0x01)   | Reserved                                 |
| 2 (0x02)   | Dual PLL, Internal VCO,<br>0-Delay       |
| 3 (0x03)   | Dual PLL, External VCO (Fin)             |
| 4 (0x04)   | Reserved                                 |
| 5 (0x05)   | Dual PLL, External VCO (Fin),<br>0-Delay |
| 6 (0x06)   | PLL2, Internal VCO                       |
| 7 (0x07)   | Reserved                                 |
| 8 (0x08)   | PLL2, Internal VCO,<br>0-Delay           |
| 9 (0x09)   | Reserved                                 |
| 10 (0x0A)  | Reserved                                 |
| 11 (0x0B)  | PLL2, External VCO (Fin)                 |
| 12 (0x0C)  | Reserved                                 |
| 13 (0x0D)  | Reserved                                 |
| 14 (0x0E)  | Reserved                                 |
| 15 (0x0F)  | Reserved                                 |
| 16 (0x10)  | Clock Distribution                       |

### 8.9.2 EN\_SYNC, Enable Synchronization

The EN\_SYNC bit (default on) must be enabled for synchronization to work. Synchronization is required for dynamic digital delay.

The synchronization enable may be turned off once the clocks are operating to save current. If EN\_SYNC is set after it has been cleared (a transition from 0 to 1), a SYNC is generated that can disrupt the active clock outputs. Setting the NO\_SYNC\_CLKoutX\_Y bits will prevent this SYNC pulse from affecting the output clocks. Setting the EN\_SYNC bit is not a valid method for synchronizing the clock outputs. See the [Section 6.9.4](#) section for more information on synchronization.

**Table 8-30. EN\_SYNC**

| R11[26] | Definition               |
|---------|--------------------------|
| 0       | Synchronization disabled |
| 1       | Synchronization enabled  |

### 8.9.3 NO\_SYNC\_CLKoutX\_Y

The NO\_SYNC\_CLKoutX\_Y bits prevent individual clock groups from becoming synchronized during a SYNC event. A reason to prevent individual clock groups from becoming synchronized is that during synchronization, the clock output is in a fixed low state or can have a glitch pulse.

By disabling SYNC on a clock group, it will continue to operate normally during a SYNC event.

Digital delay requires a SYNC operation to take effect. If NO\_SYNC\_CLKoutX\_Y is set before a SYNC event, the digital delay value will be unused.

Setting the NO\_SYNC\_CLKoutX\_Y bit has no effect on clocks already synchronized together.

**Table 8-31. NO\_SYNC\_CLKoutX\_Y Programming Addresses**

| NO_SYNC_CLKoutX_Y | Programming Address |
|-------------------|---------------------|
| CLKout0 and 1     | R11:20              |
| CLKout2 and 3     | R11:21              |
| CLKout4 and 5     | R11:22              |
| CLKout6 and 7     | R11:23              |
| CLKout8 and 9     | R11:24              |
| CLKout10 and 11   | R11:25              |

**Table 8-32. NO\_SYNC\_CLKoutX\_Y**

| R11[25, 24, 23, 22, 21, 20] | Definition                     |
|-----------------------------|--------------------------------|
| 0                           | CLKoutX_Y will synchronize     |
| 1                           | CLKoutX_Y will not synchronize |



### 8.9.4 SYNC\_MUX

Mux controlling SYNC pin when type is an output.

All the outputs logic is active high when SYNC\_TYPE = 3 (Output). All the outputs logic is active low when SYNC\_TYPE = 4 (Output Inverted). For example, when SYNC\_MUX = 0 (Logic Low) and SYNC\_TYPE = 3 (Output) then SYNC outputs a logic low. When SYNC\_MUX = 0 (Logic Low) and SYNC\_TYPE = 4 (Output Inverted) then SYNC outputs a logic high.

**Table 8-33. SYNC\_MUX, 2 bits**

| R11[19:18] | Sync pin output |
|------------|-----------------|
| 0 (0x00)   | Logic Low       |
| 1 (0x01)   | Reserved        |
| 2 (0x02)   | Reserved        |
| 3 (0x03)   | uWire Readback  |

### 8.9.5 SYNC\_QUAL

When SYNC\_QUAL is set, clock outputs will be synchronized to an existing clock output selected by FEEDBACK\_MUX. By using the NO\_SYNC\_CLKoutX\_Y bits, selected clock outputs will not be interrupted during the SYNC event.

Qualifying the SYNC by an output clock means that the pulse which turns the clock outputs off and on will have a fixed time relationship to the qualifying output clock.

SYNC\_QUAL = 1 requires CLKout4\_5\_PD = 0 for proper operation. CLKout4\_TYPE and CLKout5\_TYPE may be set to Powerdown mode.

See [Section 7.9.2](#) for more information.

**Table 8-34. SYNC\_QUAL**

| R11[17] | Mode  |
|---------|---|
| 0       | No qualification  |
| 1       | Qualification by clock output from feedback mux<br>(Must set<br>CLKout4_5_PD = 0) |

### 8.9.6 SYNC\_POL\_INV

Sets the polarity of the SYNC pin when input. When SYNC is asserted the clock outputs will transition to a low state.

See [Section 7.9.2](#) for more information on SYNC. A SYNC event can be generated by toggling this bit through the MICROWIRE interface.

**Table 8-35. SYNC\_POL\_INV**

| R11[16] | Polarity            |
|---------|---------------------|
| 0       | SYNC is active high |
| 1       | SYNC is active low  |

### 8.9.7 SYNC\_EN\_AUTO

When set, causes a SYNC event to occur when programming register R0 to R5 to adjust digital delay values.

The SYNC event will coincide with the LEuWire pin falling edge.

Refer to [Section 8.1](#) for more information on possible special programming considerations when SYNC\_EN\_AUTO = 1.

**Table 8-36. SYNC\_EN\_AUTO**

| R11[15] | Mode                      |
|---------|---------------------------|
| 0       | Manual SYNC               |
| 1       | SYNC Internally Generated |

### 8.9.8 SYNC\_TYPE

Sets the IO type of the SYNC pin.

**Table 8-37. SYNC\_TYPE, 3 bits**

| R11[14:12] | Polarity                    |
|------------|-----------------------------|
| 0 (0x00)   | Input                       |
| 1 (0x01)   | Input /w pull-up resistor   |
| 2 (0x02)   | Input /w pull-down resistor |
| 3 (0x03)   | Output (push-pull)          |
| 4 (0x04)   | Output inverted (push-pull) |
| 5 (0x05)   | Output (open source)        |
| 6 (0x06)   | Output (open drain)         |

When in output mode the SYNC input is forced to 0 regardless of the SYNC\_MUX setting. A synchronization can then be activated by uWire by programming the SYNC\_POL\_INV register to active low to assert SYNC. SYNC can then be released by programming SYNC\_POL\_INV to active high. Using this uWire programming method to create a SYNC event saves the need for an IO pin from another device.

### 8.9.9 EN\_PLL2\_XTAL

If an external crystal is being used to implement a discrete VCXO, the internal feedback amplifier must be enabled with this bit in order to complete the oscillator circuit.

**Table 8-38. EN\_PLL2\_XTAL**

| R11[5] | Oscillator Amplifier State |
|--------|----------------------------|
| 0      | Disabled                   |
| 1      | Enabled                    |

## 8.10 REGISTER R12

### 8.10.1 LD\_MUX

LD\_MUX sets the output value of the LD pin.

All the outputs logic is active high when LD\_TYPE = 3 (Output). All the outputs logic is active low when LD\_TYPE = 4 (Output Inverted). For example, when LD\_MUX = 0 (Logic Low) and LD\_TYPE = 3 (Output) then Status\_LD outputs a logic low. When LD\_MUX = 0 (Logic Low) and LD\_TYPE = 4 (Output Inverted) then Status\_LD outputs a logic high.

**Table 8-39. LD\_MUX, 5 bits**

| R12[31:27] | Divide                  |
|------------|-------------------------|
| 0 (0x00)   | Logic Low               |
| 1 (0x01)   | PLL1 DLD                |
| 2 (0x02)   | PLL2 DLD                |
| 3 (0x03)   | PLL1 & PLL2 DLD         |
| 4 (0x04)   | Holdover Status         |
| 5 (0x05)   | DAC Locked              |
| 6 (0x06)   | Reserved                |
| 7 (0x07)   | uWire Readback          |
| 8 (0x08)   | DAC Rail                |
| 9 (0x09)   | DAC Low                 |
| 10 (0x0A)  | DAC High                |
| 11 (0x0B)  | PLL1_N                  |
| 12 (0x0C)  | PLL1_N/2                |
| 13 (0x0D)  | PLL2 N                  |
| 14 (0x0E)  | PLL2 N/2                |
| 15 (0x0F)  | PLL1_R                  |
| 16 (0x10)  | PLL1_R/2                |
| 17 (0x11)  | PLL2 R <sup>(1)</sup>   |
| 18 (0x12)  | PLL2 R/2 <sup>(1)</sup> |

(1) Only valid when HOLDOVER\_MUX is not set to 2 (PLL2\_DLD) or 3 (PLL1 & PLL2 DLD).

### 8.10.2 LD\_TYPE

Sets the IO type of the LD pin.

**Table 8-40. LD\_TYPE, 3 bits**

| R12[26:24] | Polarity                    |
|------------|-----------------------------|
| 0 (0x00)   | Reserved                    |
| 1 (0x01)   | Reserved                    |
| 2 (0x02)   | Reserved                    |
| 3 (0x03)   | Output (push-pull)          |
| 4 (0x04)   | Output inverted (push-pull) |
| 5 (0x05)   | Output (open source)        |
| 6 (0x06)   | Output (open drain)         |

### 8.10.3 SYNC\_PLLX\_DLD

By setting SYNC\_PLLX\_DLD a SYNC mode will be engaged (asserted SYNC) until PLL1 and/or PLL2 locks.

SYNC\_QUAL must be 0 to use this functionality.

**Table 8-41. SYNC\_PLL2\_DLD**

| R12[23] | Sync Mode Forced |
|---------|------------------|
| 0       | No               |
| 1       | Yes              |

**Table 8-42. SYNC\_PLL1\_DLD**

| R12[22] | Sync Mode Forced |
|---------|------------------|
| 0       | No               |
| 1       | Yes              |

### 8.10.4 EN\_TRACK

Enable the DAC to track the PLL1 tuning voltage. For optional use in in holdover mode.

Tracking can be used to monitor PLL1 voltage by readback of DAC\_CNT register in any mode.

**Table 8-43. EN\_TRACK**

| R12[8] | DAC Tracking |
|--------|--------------|
| 0      | Disabled     |
| 1      | Enabled      |

### 8.10.5 HOLDOVER\_MODE

Enable the holdover mode.

**Table 8-44. HOLDOVER\_MODE, 2 bits**

| R12[7:6] | Holdover Mode |
|----------|---------------|
| 0        | Reserved      |
| 1        | Disabled      |
| 2        | Enabled       |
| 3        | Reserved      |

## 8.11 REGISTER R13

### 8.11.1 HOLDOVER\_MUX

HOLDOVER\_MUX sets the output value of the Status\_Holdover pin.

The outputs are active high when HOLDOVER\_TYPE = 3 (Output). The outputs are active low when HOLDOVER\_TYPE = 4 (Output Inverted).

**Table 8-45. HOLDOVER\_MUX, 5 bits**

| R13[31:27] | Divide                  |
|------------|-------------------------|
| 0 (0x00)   | Logic Low               |
| 1 (0x01)   | PLL1 DLD                |
| 2 (0x02)   | PLL2 DLD                |
| 3 (0x03)   | PLL1 & PLL2 DLD         |
| 4 (0x04)   | Holdover Status         |
| 5 (0x05)   | DAC Locked              |
| 6 (0x06)   | Reserved                |
| 7 (0x07)   | uWire Readback          |
| 8 (0x08)   | DAC Rail                |
| 9 (0x09)   | DAC Low                 |
| 10 (0x0A)  | DAC High                |
| 11 (0x0B)  | PLL1 N                  |
| 12 (0x0C)  | PLL1 N/2                |
| 13 (0x0D)  | PLL2 N                  |
| 14 (0x0E)  | PLL2 N/2                |
| 15 (0x0F)  | PLL1 R                  |
| 16 (0x10)  | PLL1 R/2                |
| 17 (0x11)  | PLL2 R <sup>(1)</sup>   |
| 18 (0x12)  | PLL2 R/2 <sup>(1)</sup> |

(1) Only valid when LD\_MUX is not set to 2 (PLL2\_DLD) or 3 (PLL1 & PLL2 DLD).

### 8.11.2 HOLDOVER\_TYPE

Sets the IO mode of the Status\_Holdover pin.

**Table 8-46. HOLDOVER\_TYPE, 3 bits**

| R13[26:24] | Polarity                    |
|------------|-----------------------------|
| 0 (0x00)   | Reserved                    |
| 1 (0x01)   | Reserved                    |
| 2 (0x02)   | Reserved                    |
| 3 (0x03)   | Output (push-pull)          |
| 4 (0x04)   | Output inverted (push-pull) |
| 5 (0x05)   | Output (open source)        |
| 6 (0x06)   | Output (open drain)         |

### 8.11.3 Status\_CLKin1\_MUX

Status\_CLKin1\_MUX sets the output value of the Status\_CLKin1 pin. If [Section 8.12.3](#) is set to an input type, this register has no effect. This MUX register only sets the output signal.

The outputs are active high when Status\_CLKin1\_TYPE = 3 (Output). The outputs are active low when Status\_CLKin1\_TYPE = 4 (Output Inverted).

**Table 8-47. Status\_CLKin1\_MUX, 3 bits**

| R13[22:20] | Divide          |
|------------|-----------------|
| 0 (0x00)   | Logic Low       |
| 1 (0x01)   | CLKin1 LOS      |
| 2 (0x02)   | CLKin1 Selected |
| 3 (0x03)   | DAC Locked      |
| 4 (0x04)   | DAC Low         |
| 5 (0x05)   | DAC High        |
| 6 (0x06)   | uWire Readback  |

### 8.11.4 Status\_CLKin0\_TYPE

Status\_CLKin0\_TYPE sets the IO type of the Status\_CLKin0 pin.

**Table 8-48. Status\_CLKin0\_TYPE, 3 bits**

| R13[18:16] | Polarity                    |
|------------|-----------------------------|
| 0 (0x00)   | Input                       |
| 1 (0x01)   | Input /w pull-up resistor   |
| 2 (0x02)   | Input /w pull-down resistor |
| 3 (0x03)   | Output (push-pull)          |
| 4 (0x04)   | Output inverted (push-pull) |
| 5 (0x05)   | Output (open source)        |
| 6 (0x06)   | Output (open drain)         |

### 8.11.5 DISABLE\_DLD1\_DET

DISABLE\_DLD1\_DET disables the HOLDOVER mode from being activated when PLL1 lock detect signal transitions from high to low.

When using Pin Select Mode as the input clock switch mode, this bit should normally be set.

**Table 8-49. DISABLE\_DLD1\_DET**

| R13[15] | Holdover DLD1 Detect                              |
|---------|---|
| 0       | PLL1 DLD causes clock switch event                |
| 1       | PLL1 DLD <b>does not</b> cause clock switch event |

### 8.11.6 Status\_CLKin0\_MUX

CLKin0\_MUX sets the output value of the Status\_CLKin0 pin. If [Section 8.11.4](#) is set to an input type, this register has no effect. This MUX register only sets the output signal.

The outputs logic is active high when Status\_CLKin0\_TYPE = 3 (Output). The outputs logic is active low when Status\_CLKin0\_TYPE = 4 (Output Inverted).

**Table 8-50. Status\_CLKin0\_MUX, 3 bits**

| R13[14:12] | Divide          |
|------------|-----------------|
| 0 (0x00)   | Logic Low       |
| 1 (0x01)   | CLKin0 LOS      |
| 2 (0x02)   | CLKin0 Selected |
| 3 (0x03)   | DAC Locked      |
| 4 (0x04)   | DAC Low         |
| 5 (0x05)   | DAC High        |
| 6 (0x06)   | uWire Readback  |

### 8.11.7 CLKin\_SELECT\_MODE

CLKin\_SELECT\_MODE sets the mode used in determining reference CLKin for PLL1.

**Table 8-51. CLKin\_SELECT\_MODE, 3 bits**

| R13[11:9] | Mode                              |
|-----------|-----------------------------------|
| 0 (0x00)  | CLKin0 Manual                     |
| 1 (0x01)  | CLKin1 Manual                     |
| 2 (0x02)  | Reserved                          |
| 3 (0x03)  | Pin Select Mode                   |
| 4 (0x04)  | Auto Mode                         |
| 5 (0x05)  | Reserved                          |
| 6 (0x06)  | Auto mode & next clock pin select |
| 7 (0x07)  | Reserved                          |

### 8.11.8 CLKin\_Sel\_INV

CLKin\_Sel\_INV sets the input polarity of Status\_CLKin0 and Status\_CLKin1 pins.

**Table 8-52. CLKin\_Sel\_INV**

| R13[8] | Input       |
|--------|-------------|
| 0      | Active High |
| 1      | Active Low  |

### 8.11.9 EN\_CLKinX

Each clock input can individually be enabled to be used during auto-switching CLKin\_SELECT\_MODE. Clock input switching priority is always CLKin0 → CLKin1.

**Table 8-53. EN\_CLKin1**

| R13[6] | Valid |
|--------|-------|
| 0      | No    |
| 1      | Yes   |

**Table 8-54. EN\_CLKin0**

| R13[5] | Valid |
|--------|-------|
| 0      | No    |
| 1      | Yes   |



## 8.12 REGISTER 14

### 8.12.1 LOS\_TIMEOUT

This bit controls the amount of time in which no activity on a CLKin causes LOS (Loss-of-Signal) to be asserted.

**Table 8-55. LOS\_TIMEOUT, 2 bits**

| R14[31:30] | Timeout          |
|------------|------------------|
| 0 (0x00)   | 1200 ns, 420 kHz |
| 1 (0x01)   | 206 ns, 2.5 MHz  |
| 2 (0x02)   | 52.9 ns, 10 MHz  |
| 3 (0x03)   | 23.7 ns, 22 MHz  |

### 8.12.2 EN\_LOS

Enables the LOS (Loss-of-Signal) timeout control.

**Table 8-56. EN\_LOS**

| R14[28] | LOS      |
|---------|----------|
| 0       | Disabled |
| 1       | Enabled  |

### 8.12.3 Status\_CLKin1\_TYPE

Sets the IO type of the Status\_CLKin1 pin.

**Table 8-57. Status\_CLKin1\_TYPE, 3 bits**

| R14[26:24] | Polarity                    |
|------------|-----------------------------|
| 0 (0x00)   | Input                       |
| 1 (0x01)   | Input /w pull-up resistor   |
| 2 (0x02)   | Input /w pull-down resistor |
| 3 (0x03)   | Output (push-pull)          |
| 4 (0x04)   | Output inverted (push-pull) |
| 5 (0x05)   | Output (open source)        |
| 6 (0x06)   | Output (open drain)         |

### 8.12.4 CLKinX\_BUF\_TYPE, PLL1 CLKinX/CLKinX\* Buffer Type

There are two input buffer types for the PLL1 reference clock inputs: either bipolar or CMOS. Bipolar is recommended for differential inputs such as LVDS and LVPECL. CMOS is recommended for DC coupled single ended inputs.

When using bipolar, CLKinX and CLKinX\* input pins must be AC coupled when using a differential or single ended input.

When using CMOS, CLKinX and CLKinX\* input pins may be AC or DC coupled with a differential input.

When using CMOS in single ended mode, the unused clock input pin (CLKinX or CLKinX\*) must be AC grounded. The used clock input pin (CLKinX\* or CLKinX) may be AC or DC coupled to the signal source.

The programming addresses table shows at what register and address the specified CLKinX\_BUF\_TYPE bit is located.

The CLKinX\_BUF\_TYPE table shows the programming definition for these registers.

**Table 8-58. CLKinX\_BUF\_TYPE Programming Addresses**

| CLKinX_BUF_TYPE | Programming Address |
|-----------------|---------------------|
| CLKin1_BUF_TYPE | R14[21]             |
| CLKin0_BUF_TYPE | R14[20]             |

**Table 8-59. CLKinX\_BUF\_TYPE**

| R14[21, 20] | CLKinX Buffer Type |
|-------------|--------------------|
| 0           | Bipolar            |
| 1           | CMOS               |

### 8.12.5 DAC\_HIGH\_TRIP

Voltage from Vcc at which holdover mode is entered if EN\_VTUNE\_RAIL\_DAC is enabled. Will also set flags which can be monitored out Status\_LD/Status\_Holdover pins.

Step size is ~51 mV

**Table 8-60. DAC\_HIGH\_TRIP, 6 bits**

| R14[19:14] | Trip voltage from Vcc (V) |
|------------|---------------------------|
| 0 (0x00)   | 1 × Vcc / 64              |
| 1 (0x01)   | 2 × Vcc / 64              |
| 2 (0x02)   | 3 × Vcc / 64              |
| 3 (0x03)   | 4 × Vcc / 64              |
| 4 (0x04)   | 5 × Vcc / 64              |
| ...        | ...                       |
| 61 (0x3D)  | 62 × Vcc / 64             |
| 62 (0x3E)  | 63 × Vcc / 64             |
| 63 (0x3F)  | 64 × Vcc / 64             |

### 8.12.6 DAC\_LOW\_TRIP

Voltage from GND at which holdover mode is entered if EN\_VTUNE\_RAIL\_DAC is enabled. Will also set flags which can be monitored out Status\_LD/Status\_Holdover pins.

Step size is ~51 mV

**Table 8-61. DAC\_LOW\_TRIP, 6 bits**

| R14[11:6] | Trip voltage from GND (V) |
|-----------|---------------------------|
| 0 (0x00)  | 1 × V <sub>cc</sub> / 64  |
| 1 (0x01)  | 2 × V <sub>cc</sub> / 64  |
| 2 (0x02)  | 3 × V <sub>cc</sub> / 64  |
| 3 (0x03)  | 4 × V <sub>cc</sub> / 64  |
| 4 (0x04)  | 5 × V <sub>cc</sub> / 64  |
| ...       | ...                       |
| 61 (0x3D) | 62 × V <sub>cc</sub> / 64 |
| 62 (0x3E) | 63 × V <sub>cc</sub> / 64 |
| 63 (0x3F) | 64 × V <sub>cc</sub> / 64 |

### 8.12.7 EN\_VTUNE\_RAIL\_DET

Enables the DAC Vtune rail detection. When the DAC achieves a specified Vtune, if this bit is enabled, the current clock input is considered invalid and an input clock switch event is generated.

**Table 8-62. EN\_VTUNE\_RAIL\_DET**

| R14[5] | State    |
|--------|----------|
| 0      | Disabled |
| 1      | Enabled  |

## 8.13 REGISTER 15

### 8.13.1 MAN\_DAC

Sets the DAC value when in manual DAC mode in ~3.2 mV steps.

**Table 8-63. MAN\_DAC, 10 bits**

| R15[31:22]   | DAC Voltage                   |
|--------------|-------------------------------|
| 0 (0x00)     | 0 × V <sub>cc</sub> / 1023    |
| 1 (0x01)     | 1 × V <sub>cc</sub> / 1023    |
| 2 (0x02)     | 2 × V <sub>cc</sub> / 1023    |
| ...          | ...                           |
| 1023 (0x3FF) | 1023 × V <sub>cc</sub> / 1023 |

### 8.13.2 EN\_MAN\_DAC

This bit enables the manual DAC mode.

**Table 8-64. EN\_MAN\_DAC**

| R15[20] | DAC Mode  |
|---------|-----------|
| 0       | Automatic |
| 1       | Manual    |

### 8.13.3 HOLDOVER\_DLD\_CNT

Lock must be valid for this many clocks of PLL1 PDF before holdover mode is exited.

**Table 8-65. HOLDOVER\_DLD\_CNT, 14 bits**

| R15[19:6]       | Exit Counts |
|-----------------|-------------|
| 0 (0x00)        | Reserved    |
| 1 (0x01)        | 1           |
| 2 (0x02)        | 2           |
| ...             | ...         |
| 16,383 (0x3FFF) | 16,383      |

### 8.13.4 FORCE\_HOLDOVER

This bit forces the holdover mode.

When holdover is forced, if in fixed CPout1 mode, then the DAC will set the programmed MAN\_DAC value. If in tracked CPout1 mode, then the DAC will set the current tracked DAC value.

Setting FORCE\_HOLDOVER does not constitute a clock input switch event unless DISABLE\_DLD1\_DET = 0, since in holdover mode, PLL1\_DLD = 0 this will trigger the clock input switch event.

**Table 8-66. FORCE\_HOLDOVER**

| R15[5] | Holdover |
|--------|----------|
| 0      | Disabled |
| 1      | Enabled  |

## 8.14 REGISTER 16

### 8.14.1 XTAL\_LVL

Sets the peak amplitude on the tunable crystal.

Increasing this value can improve the crystal oscillator phase noise performance at the cost of increased current and higher crystal power dissipation levels.

**Table 8-67. XTAL\_LVL, 2 bits**

| R15[31:22] | Peak Amplitude <sup>(1)</sup> |
|------------|-------------------------------|
| 0 (0x00)   | 1.65 Vpp                      |
| 1 (0x01)   | 1.75 Vpp                      |
| 2 (0x02)   | 1.90 Vpp                      |
| 3 (0x03)   | 2.05 Vpp                      |

(1) At crystal frequency of 20.48 MHz

## 8.15 REGISTER 23

This register must not be programmed, it is a readback only register.

### 8.15.1 DAC\_CNT

The DAC\_CNT register is 10 bits in size and located at readback bit position [23:14]. When using tracking mode for holdover, the DAC value can be readback at this address.

## 8.16 REGISTER 24

### 8.16.1 PLL2\_C4\_LF, PLL2 Integrated Loop Filter Component

Internal loop filter components are available for PLL2, enabling either 3rd or 4th order loop filters without requiring external components.

Internal loop filter capacitor C4 can be set according to the following table.

**Table 8-68. PLL2\_C4\_LF, 4 bits**

| R24[31:28] | Loop Filter Capacitance (pF) |
|------------|------------------------------|
| 0 (0x00)   | 10 pF                        |
| 1 (0x01)   | 15 pF                        |
| 2 (0x02)   | 29 pF                        |
| 3 (0x03)   | 34 pF                        |
| 4 (0x04)   | 47 pF                        |
| 5 (0x05)   | 52 pF                        |
| 6 (0x06)   | 66 pF                        |
| 7 (0x07)   | 71 pF                        |
| 8 (0x08)   | 103 pF                       |
| 9 (0x09)   | 108 pF                       |
| 10 (0x0A)  | 122 pF                       |
| 11 (0x0B)  | 126 pF                       |
| 12 (0x0C)  | 141 pF                       |
| 13 (0x0D)  | 146 pF                       |
| 14 (0x0E)  | Reserved                     |
| 15 (0x0F)  | Reserved                     |

### 8.16.2 PLL2\_C3\_LF, PLL2 Integrated Loop Filter Component

Internal loop filter components are available for PLL2, enabling either 3rd or 4th order loop filters without requiring external components.

Internal loop filter capacitor C3 can be set according to the following table.

**Table 8-69. PLL2\_C3\_LF, 4 bits**

| R24[27:24] | Loop Filter Capacitance(pF) |
|------------|-----------------------------|
| 0 (0x00)   | 10 pF                       |
| 1 (0x01)   | 11 pF                       |
| 2 (0x02)   | 15 pF                       |
| 3 (0x03)   | 16 pF                       |
| 4 (0x04)   | 19 pF                       |
| 5 (0x05)   | 20 pF                       |
| 6 (0x06)   | 24 pF                       |
| 7 (0x07)   | 25 pF                       |
| 8 (0x08)   | 29 pF                       |
| 9 (0x09)   | 30 pF                       |
| 10 (0x0A)  | 33 pF                       |
| 11 (0x0B)  | 34 pF                       |
| 12 (0x0C)  | 38 pF                       |
| 13 (0x0D)  | 39 pF                       |
| 14 (0x0E)  | Reserved                    |
| 15 (0x0F)  | Reserved                    |

### 8.16.3 PLL2\_R4\_LF, PLL2 Integrated Loop Filter Component

Internal loop filter components are available for PLL2, enabling either 3rd or 4th order loop filters without requiring external components.

Internal loop filter resistor R4 can be set according to the following table.

**Table 8-70. PLL2\_R4\_LF, 3 bits**

| R24[22:20] | Resistance |
|------------|------------|
| 0 (0x00)   | 200 Ω      |
| 1 (0x01)   | 1 kΩ       |
| 2 (0x02)   | 2 kΩ       |
| 3 (0x03)   | 4 kΩ       |
| 4 (0x04)   | 16 kΩ      |
| 5 (0x05)   | Reserved   |
| 6 (0x06)   | Reserved   |
| 7 (0x07)   | Reserved   |

### 8.16.4 PLL2\_R3\_LF, PLL2 Integrated Loop Filter Component

Internal loop filter components are available for PLL2, enabling either 3rd or 4th order loop filters without requiring external components.

Internal loop filter resistor R3 can be set according to the following table.

**Table 8-71. PLL2\_R3\_LF, 3 bits**

| R24[18:16] | Resistance    |
|------------|---------------|
| 0 (0x00)   | 200 $\Omega$  |
| 1 (0x01)   | 1 k $\Omega$  |
| 2 (0x02)   | 2 k $\Omega$  |
| 3 (0x03)   | 4 k $\Omega$  |
| 4 (0x04)   | 16 k $\Omega$ |
| 5 (0x05)   | Reserved      |
| 6 (0x06)   | Reserved      |
| 7 (0x07)   | Reserved      |

### 8.16.5 PLL1\_N\_DLY

Increasing delay of PLL1\_N\_DLY will cause the outputs to lead from CLKinX. For use in 0-delay mode.

**Table 8-72. PLL1\_N\_DLY, 3 bits**

| R24[14:12] | Definition |
|------------|------------|
| 0 (0x00)   | 0 ps       |
| 1 (0x01)   | 205 ps     |
| 2 (0x02)   | 410 ps     |
| 3 (0x03)   | 615 ps     |
| 4 (0x04)   | 820 ps     |
| 5 (0x05)   | 1025 ps    |
| 6 (0x06)   | 1230 ps    |
| 7 (0x07)   | 1435 ps    |

### 8.16.6 PLL1\_R\_DLY

Increasing delay of PLL1\_R\_DLY will cause the outputs to lag from CLKinX. For use in 0-delay mode.

**Table 8-73. PLL1\_R\_DLY, 3 bits**

| R24[10:8] | Definition |
|-----------|------------|
| 0 (0x00)  | 0 ps       |
| 1 (0x01)  | 205 ps     |
| 2 (0x02)  | 410 ps     |
| 3 (0x03)  | 615 ps     |
| 4 (0x04)  | 820 ps     |
| 5 (0x05)  | 1025 ps    |
| 6 (0x06)  | 1230 ps    |
| 7 (0x07)  | 1435 ps    |



### 8.16.7 PLL1\_WND\_SIZE

PLL1\_WND\_SIZE sets the window size used for digital lock detect for PLL1. If the phase error between the reference and feedback of PLL1 is less than specified time, then the PLL1 lock counter increments.

Refer to [Section 9.6](#) for more information.

**Table 8-74. PLL1\_WND\_SIZE, 2 bits**

| R24[7:6] | Definition |
|----------|------------|
| 0        | 5.5 ns     |
| 1        | 10 ns      |
| 2        | 18.6 ns    |
| 3        | 40 ns      |

## 8.17 REGISTER 25

### 8.17.1 DAC\_CLK\_DIV

The DAC update clock frequency is the PLL1 phase detector frequency divided by this divisor.

**Table 8-75. DAC\_CLK\_DIV, 10 bits**

| R25[31:22]    | Divide   |
|---------------|----------|
| 0 (0x00)      | Reserved |
| 1 (0x01)      | 1        |
| 2 (0x02)      | 2        |
| 3 (0x03)      | 3        |
| ...           | ...      |
| 1,022 (0x3FE) | 1022     |
| 1,023 (0x3FF) | 1023     |

### 8.17.2 PLL1\_DLD\_CNT

The reference and feedback of PLL1 must be within the window of phase error as specified by PLL1\_WND\_SIZE for this many phase detector cycles before PLL1 digital lock detect is asserted.

Refer to [Section 9.6](#) for more information.

**Table 8-76. PLL1\_DLD\_CNT, 14 bits**

| R25[19:6]       | Divide   |
|-----------------|----------|
| 0               | Reserved |
| 1               | 1        |
| 2               | 2        |
| 3               | 3        |
| ...             | ...      |
| 16,382 (0x3FFE) | 16,382   |
| 16,383 (0x3FFF) | 16,383   |

## 8.18 REGISTER 26

### 8.18.1 PLL2\_WND\_SIZE

PLL2\_WND\_SIZE sets the window size used for digital lock detect for PLL2. If the phase error between the reference and feedback of PLL2 is less than specified time, then the PLL2 lock counter increments. This value must be programmed to 2 (3.7 ns).

Refer to [Section 9.6](#) for more information.

**Table 8-77. PLL2\_WND\_SIZE, 2 bits**

| R26[31:30] | Definition |
|------------|------------|
| 0          | Reserved   |
| 1          | Reserved   |
| 2          | 3.7 ns     |
| 3          | Reserved   |

### 8.18.2 EN\_PLL2\_REF\_2X, PLL2 Reference Frequency Doubler

Enabling the PLL2 reference frequency doubler allows for higher phase detector frequencies on PLL2 than would normally be allowed with the given VCXO or Crystal frequency.

Higher phase detector frequencies reduces the PLL N values which makes the design of wider loop bandwidth filters possible.

**Table 8-78. EN\_PLL2\_REF\_2X**

| R26[29] | Description                      |
|---------|----------------------------------|
| 0       | Reference frequency normal       |
| 1       | Reference frequency doubled (2x) |

### 8.18.3 PLL2\_CP\_POL, PLL2 Charge Pump Polarity

PLL2\_CP\_POL sets the charge pump polarity for PLL2. The internal VCO requires the negative charge pump polarity to be selected. Many VCOs use positive slope.

A positive slope VCO increases output frequency with increasing voltage. A negative slope VCO decreases output frequency with increasing voltage.

**Table 8-79. PLL2\_CP\_POL**

| R26[28] | Description             |
|---------|-------------------------|
| 0       | Negative Slope VCO/VCXO |
| 1       | Positive Slope VCO/VCXO |

### 8.18.4 PLL2\_CP\_GAIN, PLL2 Charge Pump Current

This bit programs the PLL2 charge pump output current level. The table below also illustrates the impact of the PLL2 TRI-STATE bit in conjunction with PLL2\_CP\_GAIN.

**Table 8-80. PLL2\_CP\_GAIN, 2 bits**

| R26[27:26] | PLL2_CP_TRI<br>R26[5] | Charge Pump Current (µA) |
|------------|-----------------------|--------------------------|
| X          | 1                     | Hi-Z                     |
| 0 (0x00)   | 0                     | 100                      |
| 1 (0x01)   | 0                     | 400                      |
| 2 (0x02)   | 0                     | 1600                     |
| 3 (0x03)   | 0                     | 3200                     |

### 8.18.5 PLL2\_DLD\_CNT

The reference and feedback of PLL2 must be within the window of phase error as specified by PLL2\_WND\_SIZE for **PLL2\_DLD\_CNT** cycles before PLL2 digital lock detect is asserted.

Refer to [Section 9.6](#) for more information

**Table 8-81. PLL2\_DLD\_CNT, 14 bits**

| R26[19:6]       | Divide   |
|-----------------|----------|
| 0 (0x00)        | Reserved |
| 1 (0x01)        | 1        |
| 2 (0x02)        | 2        |
| 3 (0x03)        | 3        |
| ...             | ...      |
| 16,382 (0x3FFE) | 16,382   |
| 16,383 (0x3FFF) | 16,383   |

### 8.18.6 PLL2\_CP\_TRI, PLL2 Charge Pump TRI-STATE

This bit allows for the PLL2 charge pump output pin, CPout2, to be placed into TRI-STATE.

**Table 8-82. PLL2\_CP\_TRI**

| R26[5] | Description                 |
|--------|-----------------------------|
| 0      | PLL2 CPout2 is active       |
| 1      | PLL2 CPout2 is at TRI-STATE |

## 8.19 REGISTER 27

### 8.19.1 PLL1\_CP\_POL, PLL1 Charge Pump Polarity

PLL1\_CP\_POL sets the charge pump polarity for PLL1. Many VCXOs use positive slope.

A positive slope VCXO increases output frequency with increasing voltage. A negative slope VCXO decreases output frequency with increasing voltage.

**Table 8-83. PLL1\_CP\_POL**

| R27[28] | Description             |
|---------|-------------------------|
| 0       | Negative Slope VCO/VCXO |
| 1       | Positive Slope VCO/VCXO |

### 8.19.2 PLL1\_CP\_GAIN, PLL1 Charge Pump Current

This bit programs the PLL1 charge pump output current level. The table below also illustrates the impact of the PLL1 TRI-STATE bit in conjunction with PLL1\_CP\_GAIN.

**Table 8-84. PLL1\_CP\_GAIN, 2 bits**

| R26[27:26] | PLL1_CP_TRI<br>R27[5] | Charge Pump Current ( $\mu$ A) |
|------------|-----------------------|--------------------------------|
| X          | 1                     | Hi-Z                           |
| 0 (0x00)   | 0                     | 100                            |
| 1 (0x01)   | 0                     | 200                            |
| 2 (0x02)   | 0                     | 400                            |
| 3 (0x03)   | 0                     | 1600                           |

### 8.19.3 CLKinX\_PreR\_DIV

The pre-R dividers before the PLL1 R divider can be programmed such that when the active clock input is switched, the frequency at the input of the PLL1 R divider will be the same. This allows PLL1 to stay in lock without needing to re-program the PLL1 R register when different clock input frequencies are used. This is especially useful in the auto CLKin switching modes.

**Table 8-85. CLKinX\_PreR\_DIV Programming Addresses**

| CLKinX_PreR_DIV | Programming Address |
|-----------------|---------------------|
| CLKin1_PreR_DIV | R27[23:22]          |
| CLKin0_PreR_DIV | R27[21:20]          |

**Table 8-86. CLKinX\_PreR\_DIV, 2 bits**

| R27[23:22, 21:20] | Divide |
|-------------------|--------|
| 0 (0x00)          | 1      |
| 1 (0x01)          | 2      |
| 2 (0x02)          | 4      |
| 3 (0x03)          | 8      |

### 8.19.4 PLL1\_R, PLL1 R Divider

The reference path into the PLL1 phase detector includes the PLL1 R divider. Refer to [Section 9.2](#) for more information on how to program the PLL dividers to lock the PLL.

The valid values for PLL1\_R are shown in the table below.

**Table 8-87. PLL1\_R, 14 bits**

| R27[19:6]       | Divide   |
|-----------------|----------|
| 0 (0x00)        | Reserved |
| 1 (0x01)        | 1        |
| 2 (0x02)        | 2        |
| 3 (0x03)        | 3        |
| ...             | ...      |
| 16,382 (0x3FFE) | 16,382   |
| 16,383 (0x3FFF) | 16,383   |

### 8.19.5 PLL1\_CP\_TRI, PLL1 Charge Pump TRI-STATE

This bit allows for the PLL1 charge pump output pin, CPout1, to be placed into TRI-STATE.

**Table 8-88. PLL1\_CP\_TRI**

| R27[5] | Description                 |
|--------|-----------------------------|
| 0      | PLL1 CPout1 is active       |
| 1      | PLL1 CPout1 is at TRI-STATE |

## 8.20 REGISTER 28

### 8.20.1 PLL2\_R, PLL2 R Divider

The reference path into the PLL2 phase detector includes the PLL2 R divider.

Refer to [Section 9.2](#) for more information on how to program the PLL dividers to lock the PLL.

The valid values for PLL2\_R are shown in the table below.

**Table 8-89. PLL2\_R, 12 bits**

| R28[31:20]    | Divide    |
|---------------|-----------|
| 0 (0x00)      | Not Valid |
| 1 (0x01)      | 1         |
| 2 (0x02)      | 2         |
| 3 (0x03)      | 3         |
| ...           | ...       |
| 4,094 (0xFFE) | 4,094     |
| 4,095 (0xFFF) | 4,095     |

### 8.20.2 PLL1\_N, PLL1 N Divider

The feedback path into the PLL1 phase detector includes the PLL1 N divider.

Refer to [Section 9.2](#) for more information on how to program the PLL dividers to lock the PLL.

The valid values for PLL1\_N are shown in the table below.

**Table 8-90. PLL1\_N, 14 bits**

| R28[19:6]     | Divide    |
|---------------|-----------|
| 0 (0x00)      | Not Valid |
| 1 (0x01)      | 1         |
| 2 (0x02)      | 2         |
| ...           | ...       |
| 4,095 (0xFFF) | 4,095     |

## 8.21 REGISTER 29

### 8.21.1 OSCin\_FREQ, PLL2 Oscillator Input Frequency Register

The frequency of the PLL2 reference input to the PLL2 Phase Detector (OSCin/OSCin\* port) must be programmed in order to support proper operation of the frequency calibration routine which locks the internal VCO to the target frequency.

**Table 8-91. OSCin\_FREQ, 3 bits**

| R29[26:24] | OSCin Frequency     |
|------------|---------------------|
| 0 (0x00)   | 0 to 63 MHz         |
| 1 (0x01)   | >63 MHz to 127 MHz  |
| 2 (0x02)   | >127 MHz to 255 MHz |
| 3 (0x03)   | Reserved            |
| 4 (0x04)   | >255 MHz to 400 MHz |

### 8.21.2 PLL2\_FAST\_PDF, High PLL2 Phase Detector Frequency

When PLL2 phase detector frequency is greater than 100 MHz, set the PLL2\_FAST\_PDF to ensure proper operation of device.

**Table 8-92. PLL2\_FAST\_PDF**

| R29[23] | PLL2 PDF                      |
|---------|-------------------------------|
| 0       | Less than or equal to 100 MHz |
| 1       | Greater than 100 MHz          |

### 8.21.3 PLL2\_N\_CAL, PLL2 N Calibration Divider

During the frequency calibration routine, the PLL uses the divide value of the PLL2\_N\_CAL register instead of the divide value of the PLL2\_N register to lock the VCO to the target frequency.

Refer to [Section 9.2](#) for more information on how to program the PLL dividers to lock the PLL.

**Table 8-93. PLL2\_N\_CAL, 18 bits**

| R29[22:5]         | Divide    |
|-------------------|-----------|
| 0 (0x00)          | Not Valid |
| 1 (0x01)          | 1         |
| 2 (0x02)          | 2         |
| ...               | ...       |
| 262,143 (0x3FFFF) | 262,143   |



## 8.22 REGISTER 30

If an internal VCO mode is used, programming Register 30 triggers the frequency calibration routine. This calibration routine will also generate a SYNC event. See [Section 7.9.2](#) for more details on a SYNC.

### 8.22.1 PLL2\_P, PLL2 N Prescaler Divider

The PLL2 N Prescaler divides the output of the VCO as selected by Mode\_MUX1 and is connected to the PLL2 N divider.

Refer to [Section 9.2](#) for more information on how to program the PLL dividers to lock the PLL.

**Table 8-94. PLL2\_P, 3 bits**

| R30[26:24] | Divide Value |
|------------|--------------|
| 0 (0x00)   | 8            |
| 1 (0x01)   | 2            |
| 2 (0x02)   | 2            |
| 3 (0x03)   | 3            |
| 4 (0x04)   | 4            |
| 5 (0x05)   | 5            |
| 6 (0x06)   | 6            |
| 7 (0x07)   | 7            |

### 8.22.2 PLL2\_N, PLL2 N Divider

The feedback path into the PLL2 phase detector includes the PLL2 N divider.

Each time register 30 is updated via the MICROWIRE interface, a frequency calibration routine runs to lock the VCO to the target frequency. During this calibration PLL2\_N is substituted with PLL2\_N\_CAL.

Refer to [Section 9.2](#) for more information on how to program the PLL dividers to lock the PLL.

The valid values for PLL2\_N are shown in the table below.

**Table 8-95. PLL2\_N, 18 bits**

| R30[22:5]         | Divide    |
|-------------------|-----------|
| 0 (0x00)          | Not Valid |
| 1 (0x01)          | 1         |
| 2 (0x02)          | 2         |
|                   | ...       |
| 262,143 (0x3FFFF) | 262,143   |

## 8.23 REGISTER 31

### 8.23.1 READBACK\_LE

Sets the required state of the LEuWire pin when performing register readback.

Refer to [Section 8.3](#).

**Table 8-96. READBACK\_LE**

| R31[21]  | Register                     |
|----------|------------------------------|
| 0 (0x00) | LE must be low for readback  |
| 1 (0x01) | LE must be high for readback |

### 8.23.2 READBACK\_ADDR

Sets the address of the register to read back when performing readback.

When reading register 12, the READBACK\_ADDR will be read back at R12[20:16].

When reading back from R31 bits 6 to 31 should be ignored. Only uWire\_LOCK is valid.

Refer to [Section 6.13](#) for more information on readback.

**Table 8-97. READBACK\_ADDR, 5 bits**

| R31[20:16] | Register |
|------------|----------|
| 0 (0x00)   | R0       |
| 1 (0x01)   | R1       |
| 2 (0x02)   | R2       |
| 3 (0x03)   | R3       |
| 4 (0x04)   | R4       |
| 5 (0x05)   | R5       |
| 6 (0x06)   | R6       |
| 7 (0x07)   | R7       |
| 8 (0x08)   | R8       |
| 9 (0x09)   | Reserved |
| 10 (0x0A)  | R10      |
| 11 (0x0B)  | R11      |
| 12 (0x0C)  | R12      |
| 13 (0x0D)  | R13      |
| 14 (0x0E)  | R14      |
| 15 (0x0F)  | R15      |
| 16 (0x10)  | Reserved |
| 17 (0x11)  | Reserved |
| ...        | ...      |
| 22 (0x16)  | Reserved |
| 23 (0x17)  | Reserved |
| 24 (0x18)  | R24      |
| 25 (0x19)  | R25      |
| 26 (0x1A)  | R26      |
| 27 (0x1B)  | R27      |
| 28 (0x1C)  | R28      |
| 29 (0x1D)  | R29      |
| 30 (0x1E)  | R30      |
| 31 (0x1F)  | R31      |

### 8.23.3 uWire\_LOCK

Setting uWire\_LOCK will prevent any changes to uWire registers R0 to R30. Only by clearing the uWire\_LOCK bit in R31 can the uWire registers be unlocked and written to once more.

It is not necessary to lock the registers to perform a readback operation.

**Table 8-98. uWire\_LOCK**

| R31[5] | State                           |
|--------|---------------------------------|
| 0      | Registers unlocked              |
| 1      | Registers locked, Write-protect |

## 9 Application Information

### 9.1 FREQUENCY PLANNING WITH THE LMK04800 FAMILY

Calculating the value of the output dividers for use with the LMK04800 family is simple due to the architecture of the LMK04800. That is, the VCO divider may be bypassed and the clock output dividers allow for even and odd output divide values from 2 to 1045. For most applications it is recommended to bypass the VCO divider.

The procedure for determining the needed LMK048xx device and clock output divider values for a set of clock output frequencies is straightforward.

1. Calculate the least common multiple (LCM) of the clock output frequencies.
2. Determine which VCO ranges will support the target clock output frequencies given the LCM.
3. Determine the clock output divide values based on VCO frequency.
4. Determine the PLL2\_P, PLL2\_N, and PLL2\_R divider values given the OSCin VCXO or crystal frequency and VCO frequency.

For example, given the following target output frequencies: 200 MHz, 120 MHz, and 25 MHz with a VCXO frequency of 40 MHz:

**First** determine the LCM of the three frequencies.  $\text{LCM}(200 \text{ MHz}, 120 \text{ MHz}, 25 \text{ MHz}) = 600 \text{ MHz}$ . The LCM frequency is the lowest frequency for which all of the target output frequencies are integer divisors of the LCM. *Note, if there is one frequency which causes the LCM to be very large, greater than 3 GHz for example, determine if there is a single frequency requirement which causes this. It may be possible to select the VCXO/crystal frequency to satisfy this frequency requirement through OSCout or CLKout6/7/8/9 driven by OSCin. In this way it is possible to get non-integer related frequencies at the outputs.*

**Second**, since the LCM is not in a VCO frequency range supported by the LMK04800 family, multiply the LCM frequency by an integer which causes it to fall into a valid VCO frequency range of an LMK048xx device. In this case  $600 \text{ MHz} * 5 = 3000 \text{ MHz}$  which is valid for the LMK04808.

**Third**, continuing the example by using a VCO frequency of 3000 MHz and the LMK04808, the CLKout dividers can be calculated by simply dividing the VCO frequency by the output frequency. To output 200 MHz, 120 MHz, and 25 MHz the output dividers will be 12, 20, and 96 respectively.

- $3000 \text{ MHz} / 200 \text{ MHz} = 15$
- $3000 \text{ MHz} / 120 \text{ MHz} = 25$
- $3000 \text{ MHz} / 25 \text{ MHz} = 120$

**Fourth**, PLL2 must be locked to its input reference. Refer to [Section 9.2](#) for more information on this topic. By programming the clock output dividers and the PLL2 dividers the VCO can lock to the frequency of 3000 MHz and the clock outputs dividers will each divide the VCO frequency down to the target output frequencies of 200 MHz, 120 MHz, and 25 MHz.

Refer to application note *AN-1865 Frequency Synthesis and Planning for PLL Architectures* ([SNAA061](#)) for more information on this topic and LCM calculations.

## 9.2 PLL PROGRAMMING

To lock a PLL the divided reference and divided feedback from VCO or VCXO must result in the same phase detector frequency. The tables below illustrate how the divides are structured for the reference path (R) and feedback path (N) depending on the MODE of the device.

**Table 9-1. PLL1 Phase Detector Frequency — Reference Path (R)**

| MODE | (R) PLL1 PDF =                              |
|------|---|
| All  | CLKinX Frequency / CLKinX_PreR_DIV / PLL1_R |

**Table 9-2. PLL1 Phase Detector Frequency — Feedback Path (N)**

| MODE                    | VCO_MUX | OSCOut0 | PLL1 PDF (N) =  |
|-------------------------|---------|---------|---|
| Internal VCO Dual PLL   | —       | Bypass  | VCXO Frequency / PLL1_N   |
|                         | —       | Divided | VCXO Frequency / OSCin_DIV / PLL1_N                             |
| Internal VCO /w 0-delay | Bypass  | —       | VCO Frequency / CLKoutX_Y_DIV / PLL1_N <sup>(1)</sup>           |
|                         | Divided | —       | VCO Frequency / VCO_DIV / CLKoutX_Y_DIV / PLL1_N <sup>(1)</sup> |

(1) The actual CLKoutX\_Y\_DIV used is selected by [Section 8.8.10](#).

**Table 9-3. PLL2 Phase Detector Frequency — Reference Path (R)**

| EN_PLL2_REF_2X | PLL2 PDF (R) =               |
|----------------|------------------------------|
| Disabled       | OSCin Frequency / PLL2_R     |
| Enabled        | OSCin Frequency * 2 / PLL2_R |

**Table 9-4. PLL2 Phase Detector Frequency — Feedback Path (N)**

| MODE                             | VCO_MUX     | PLL2 PDF (N) =                                   |
|----------------------------------|-------------|--|
| Dual PLL                         | VCO         | VCO Frequency / PLL2_P / PLL2_N                  |
| Dual PLL /w 0-delay              |             |  |
| Single PLL                       |             |  |
| Dual PLL                         | VCO Divider | VCO Frequency / VCO_DIV / PLL2_P / PLL2_N        |
| Dual PLL /w 0-delay              |             |  |
| Single PLL                       |             |  |
| Dual PLL External VCO            | —           | VCO Frequency / VCO_DIV / PLL2_P / PLL2_N        |
| Dual PLL External VCO /w 0-delay |             |  |
| Single PLL /w 0-delay            | VCO         | VCO Frequency / CLKoutX_Y_DIV / PLL2_N           |
|                                  | VCO Divider | VCO Frequency / VCO_DIV / CLKoutX_Y_DIV / PLL2_N |

**Table 9-5. PLL2 Phase Detector Frequency — Feedback Path (N) during VCO Frequency Calibration**

| MODE                   | VCO_MUX     | PLL2 PDF (N_CAL) =                            |
|------------------------|-------------|---|
| All Internal VCO Modes | VCO         | VCO Frequency / PLL2_P / PLL2_N_CAL           |
|                        | VCO Divider | VCO Frequency / VCO_DIV / PLL2_P / PLL2_N_CAL |

### 9.2.1 Example PLL2 N Divider Programming

To program PLL2 to lock an LMK04808 using Dual PLL mode to a VCO frequency of 3000 MHz using a 40 MHz VCXO reference, first determine the total PLL2 N divide value. This is VCO Frequency / PLL2 phase detector frequency. This example assumes a PLL2 R divide value of 1 which results in PLL2 phase detector frequency the same as PLL2 reference frequency (40 MHz).  $3000 \text{ MHz} / 40 \text{ MHz} = 75$ , so the total PLL2 N divide value is 75.

The dividers in the PLL2 N feedback path for Dual PLL mode include PLL2\_P and PLL2\_N. PLL2\_P can be programmed from 2 to 8 even and odd. PLL2\_N can be programmed from 1 to 263,143 even and odd. Since the total PLL2 N divide value of 75 contains the factors 3, 3, and 5, it would be allowable to program PLL2\_P to 3 or 5. It is simplest to use the smallest divide, so PLL2\_P = 3, and PLL2\_N = 25 which results in a Total PLL2 N = 75.

For this example and in most cases, PLL2\_N\_CAL will have the same value as PLL2\_N. However when using Single PLL mode with 0-delay, the values will differ. When using an external VCO, PLL2\_N\_CAL value is unused.

## 9.3 LOOP FILTER

Each PLL of the LMK04800 family requires a dedicated loop filter.

### 9.3.1 PLL1

The loop filter for PLL1 must be connected to the CPout1 pin. [Figure 9-1](#) shows a simple 2-pole loop filter. The output of the filter drives an external VCXO module or discrete implementation of a VCXO using a crystal resonator and external varactor diode. Higher order loop filters may be implemented using additional external R and C components. It is recommended the loop filter for PLL1 result in a total closed loop bandwidth in the range of 10 Hz to 200 Hz. The design of the loop filter is application specific and highly dependent on parameters such as the phase noise of the reference clock, VCXO phase noise, and phase detector frequency for PLL1. TI's Clock Conditioner Owner's Manual covers this topic in detail and Texas Instruments Clock Design Tool can be used to simulate loop filter designs for both PLLs. These resources may be found:

[http://www.ti.com/lscs/ti/analog/clocksandtimers/clocks\\_and\\_timers.page](http://www.ti.com/lscs/ti/analog/clocksandtimers/clocks_and_timers.page).

### 9.3.2 PLL2

As shown in [Figure 9-1](#), the charge pump for PLL2 is directly connected to the optional internal loop filter components, which are normally used only if either a third or fourth pole is needed. The first and second poles are implemented with external components. The loop must be designed to be stable over the entire application-specific tuning range of the VCO. The designer should note the range of  $K_{VCO}$  listed in the table of Electrical Characteristics and how this value can change over the expected range of VCO tuning frequencies. Because loop bandwidth is directly proportional to  $K_{VCO}$ , the designer should model and simulate the loop at the expected extremes of the desired tuning range, using the appropriate values for  $K_{VCO}$ .

When designing with the integrated loop filter of the LMK04800 family, considerations for minimum resistor thermal noise often lead one to the decision to design for the minimum value for integrated resistors, R3 and R4.

Both the integrated loop filter resistors (R3 and R4) and capacitors (C3 and C4) also restrict the maximum loop bandwidth. However, these integrated components do have the advantage that they are closer to the VCO and can therefore filter out some noise and spurs better than external components. For this reason, a common strategy is to minimize the internal loop filter resistors and then design for the largest internal capacitor values that permit a wide enough loop bandwidth. In situations where spur requirements are very stringent and there is margin on phase noise, a feasible strategy would be to design a loop filter with integrated resistor values larger than their minimum value.

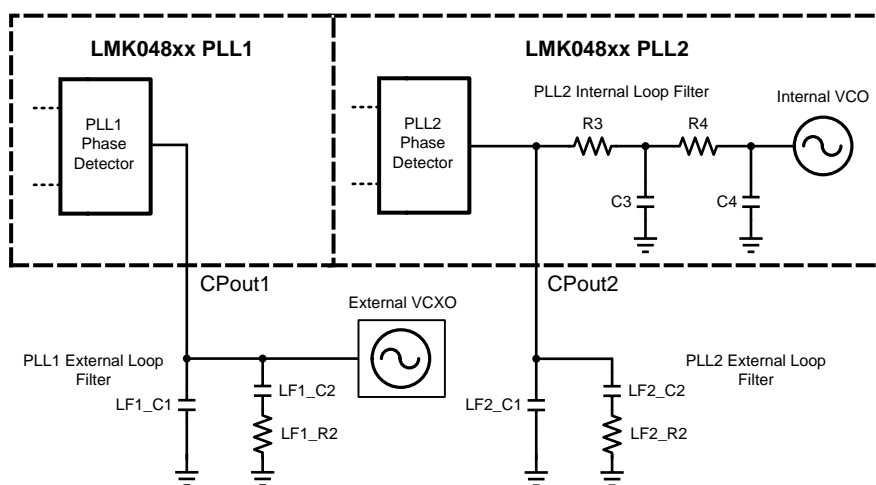


Figure 9-1. PLL1 and PLL2 Loop Filters

### 9.4 SYSTEM LEVEL DIAGRAM

Figure 9-2 and Figure 9-3 show an LMK04800 family device with external circuitry for clocking and for power supply to serve as a guideline for good practices when designing with the LMK04800 family. Refer to Section 9.5 for more details on the pin connections and bypassing recommendations. Also refer to the evaluation board. PCB design will also play a role in device performance.

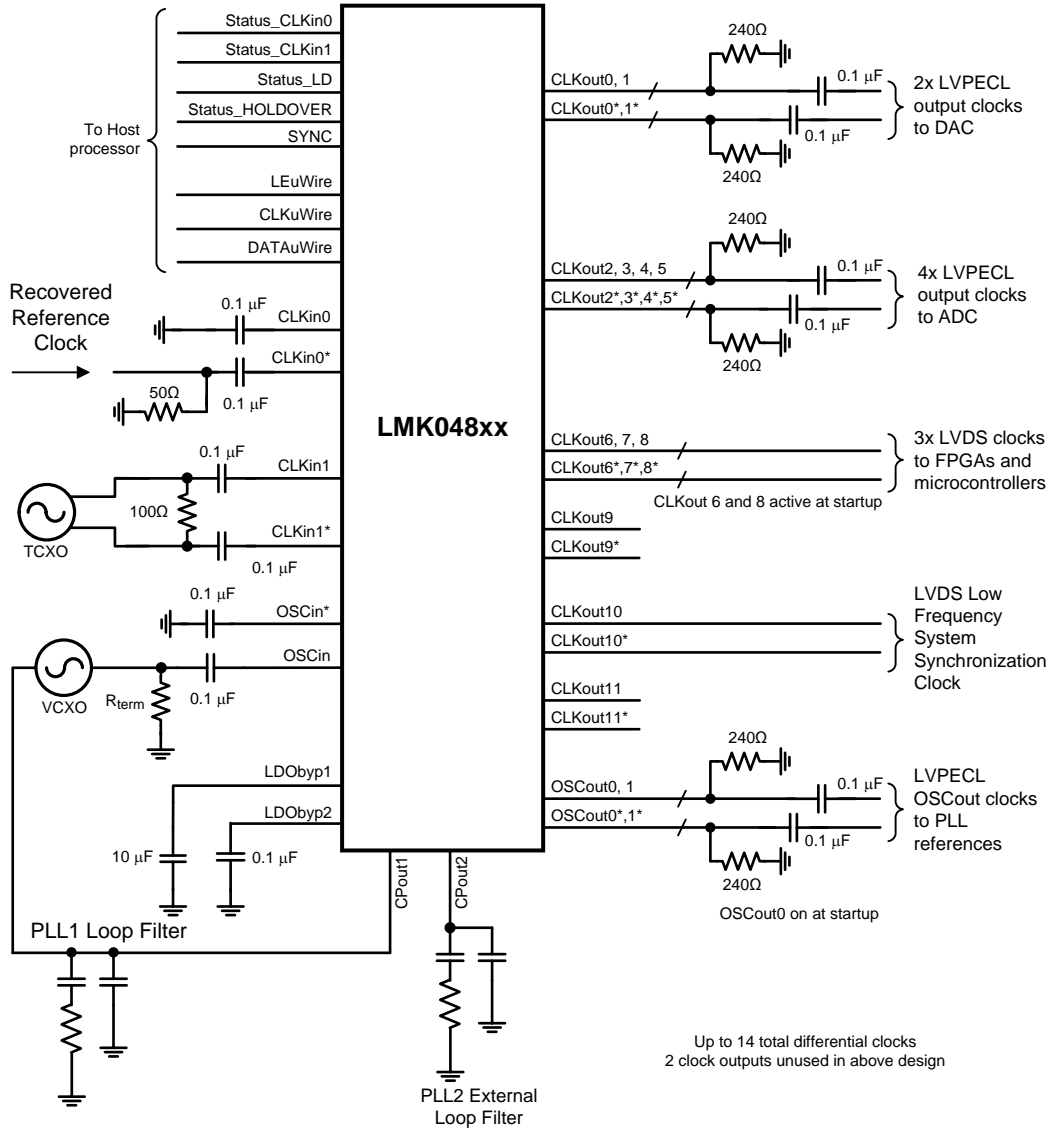


Figure 9-2. Example Application – System Schematic Except for Power

Figure 9-2 shows the primary reference clock input is at CLKin0/0\*. A secondary reference clock is driving CLKin1/1\*. Both clocks are depicted as AC coupled differential drivers. The VCXO attached to the OSCin/OSCin\* port is configured as an AC coupled single-ended driver. Any of the input ports (CLKin0/0\*, CLKin1/1\*, or OSCin/OSCin\*) may be configured as either differential or single-ended. These options are discussed later in the data sheet.

See Section 9.3 for more information on PLL1 and PLL2 loop filters.



The clock outputs are all AC coupled with 0.1  $\mu\text{F}$  capacitors. Some clock outputs are depicted as LVPECL with 240  $\Omega$  emitter resistors and some clock outputs as LVDS. However, the output format of the clock outputs will vary by user programming, so the user should use the appropriate source termination for each clock output. Later sections of this data sheet illustrate alternative methods for AC coupling, DC coupling and terminating the clock outputs.

PCB design will influence crosstalk performance. Tightly coupled clock traces will have less crosstalk than loosely coupled clock traces. Also proximity to other clocks traces will influence crosstalk.

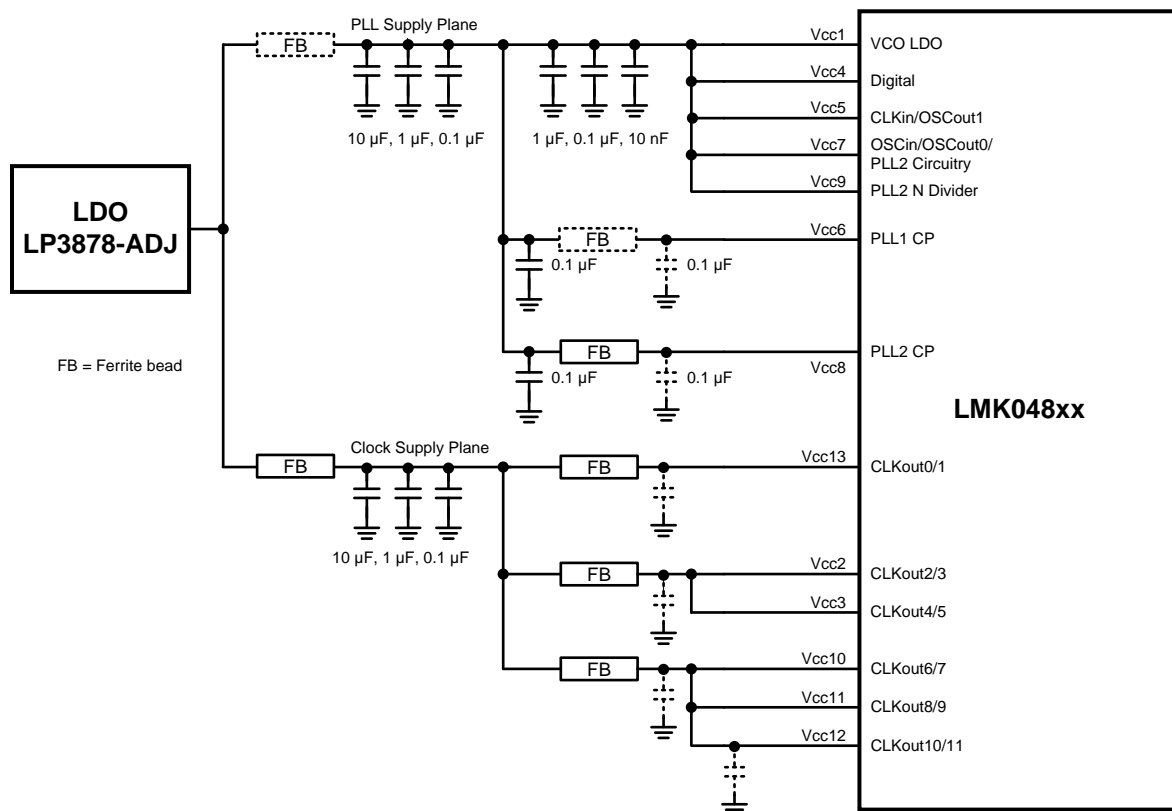


Figure 9-3. Example Application – Power System Schematic

Figure 9-3 shows an example decoupling and bypassing scheme for the LMK04800, which could apply to configurations shown in Figure 9-1 or Figure 9-2. Components drawn in dotted lines are optional (see Section 9.5). Two power planes are used in these example designs, one for the clock outputs and one for PLL circuits. It is possible to reduce the number of decoupling components by tying together clock output Vcc pins for CLKouts that share the same frequency or otherwise can tolerate potential crosstalk between outputs with different frequencies. In the two examples, Vcc2 and Vcc3 can be tied together since CLKout2/3 and CLKout4/5 will operate at the same frequencies. Vcc10, Vcc11, and Vcc12 can be tied together since potential crosstalk between the FPGA/SerDes clocks and low-frequency synchronization clocks will not impact the performance of these digital interfaces, which typically have less stringent jitter requirements. PCB design will influence impedance to the supply. Vias and traces will increase the impedance to the power supply. Ensure good direct return current paths.

## 9.5 PIN CONNECTION RECOMMENDATIONS

### 9.5.1 Vcc Pins and Decoupling

All Vcc pins must always be connected.

Integrated capacitance on the LMK048xx makes external high frequency decoupling capacitors ( $\leq 1$  nF) unnecessary. The internal capacitance is more effective at filtering high frequency noise than off device bypass capacitance because there is no bond wire inductance between the LMK048xx circuit and the bypass capacitor.

#### 9.5.1.1 Vcc2, Vcc3, Vcc10, Vcc11, Vcc12, Vcc13 (CLKout Vccs)

Each of these pins has an internal 200 pF of capacitance.

Ferrite beads may be used to reduce crosstalk between different clock output frequencies on the same LMK048xx device. Ferrite beads placed between the power supply and a clock Vcc pin will reduce noise between the Vcc pin and the power supply. When several output clocks share the same frequency a single ferrite bead can be used between the power supply and each same frequency CLKout Vcc pin.

When using ferrite beads on CLKout Vcc pins, care must be taken to ensure the power supply can source the needed switching current.

- In most cases a ferrite bead may be placed and the internal capacitance is sufficient.
- If a ferrite bead is used with a low frequency output (typically  $\leq 10$  MHz) and a high current switching clock output format such as non-complementary LVCMOS or high swing LVPECL is used, then...
  - the ferrite bead can be removed to the lower impedance to the main power supply and bypass capacitors, or
  - localized capacitance can be placed between the ferrite bead and Vcc pin to support the switching current.
- Note that decoupling capacitors used between the ferrite bead and a CLKout Vcc pin can permit high frequency switching noise to couple through the capacitors into the ground plane and onto other CLKout Vcc pins with decoupling capacitors. This can degrade crosstalk performance.

#### 9.5.1.2 Vcc1 (VCO), Vcc4 (Digital), and Vcc9 (PLL2)

Each of these pins has internal bypass capacitance.

Ferrite beads should not be used between these pins and the power supply/large bypass capacitors because these Vcc pins don't produce much noise or a ferrite bead can cause phase noise disturbances and resonances.

The typical application diagram in [Figure 9-3](#) shows all these Vccs connected to together to Vcc without a ferrite bead.

#### 9.5.1.3 Vcc6 (PLL1 Charge Pump) and Vcc8 (PLL2 Charge Pump)

Each of these pins has an internal bypass capacitor.

Use of a ferrite bead between the power supply/large bypass capacitors and PLL1 is optional. PLL1 charge pump can be connected directly to Vcc along with Vcc1, Vcc4, and Vcc9. Depending on the application, a 0.1 uF capacitor may be placed close to PLL1 charge pump Vcc pin.

A ferrite bead should be placed between the power supply/large bypass capacitors and Vcc8. Most applications have high PLL2 phase detector frequencies and ( $> 50$  MHz) such that the internal bypassing is sufficient and a ferrite bead can be used to isolate this switching noise from other circuits. For lower phase detector frequencies a ferrite bead is optional and depending on application a 0.1 uF capacitor may be added on Vcc8.

#### 9.5.1.4 Vcc5 (CLKin & OSCout1), Vcc7 (OS Cin & OSCout0)

Each of these pins has an internal 100 pF of capacitance. No ferrite bead should be placed between the power supply/large bypass capacitors and Vcc5 or Vcc7.

These pins are unique since they supply an output clock and other circuitry.

Vcc5 supplies CLKin and OSCout1.

Vcc7 supplies OS Cin, OSCout0, and PLL2 circuitry.

#### 9.5.2 LVPECL Outputs

When using an LVPECL output it is not recommended to place a capacitor to ground on the output as might be done when using a capacitor input LC lowpass filter. The capacitor will appear as a short to the LVPECL output drivers which are able to supply large amounts of switching current. The effect of the LVPECL sourcing large switching currents can result in:

1. Large switching currents through the Vcc pin of the LVPECL power supply resulting in more Vcc noise and possible Vcc spikes.
2. Large switching currents injected into the ground plane through the capacitor which could couple onto other Vcc pins with bypass capacitors to ground resulting in more Vcc noise and possible Vcc spikes.

#### 9.5.3 Unused Clock Outputs

Leave unused clock outputs floating and powered down.

#### 9.5.4 Unused Clock Inputs

Unused clock inputs can be left floating.

#### 9.5.5 LDO Bypass

The LDObyp1 and LDObyp2 pins should be connected to GND through external capacitors, as shown in the diagram.

## 9.6 DIGITAL LOCK DETECT FREQUENCY ACCURACY

The digital lock detect circuit is used to determine PLL1 locked, PLL2 locked, and holdover exit events. A window size and lock count register are programmed to set a ppm frequency accuracy of reference to feedback signals of the PLL for each event to occur. When a PLL digital lock event occurs the PLL's digital lock detect is asserted true. When the holdover exit event occurs, the device will exit holdover mode.

| Event         | PLL  | Window size   | Lock count       |
|---------------|------|---------------|------------------|
| PLL1 Locked   | PLL1 | PLL1_WND_SIZE | PLL1_DLD_CNT     |
| PLL2 Locked   | PLL2 | PLL2_WND_SIZE | PLL2_DLD_CNT     |
| Holdover exit | PLL1 | PLL1_WND_SIZE | HOLDOVER_DLD_CNT |

For a digital lock detect event to occur there must be a "lock count" number of phase detector cycles of PLLX during which the time/phase error of the PLLX\_R reference and PLLX\_N feedback signal edges are within the user programmable "window size." Since there must be at least "lock count" phase detector events before a lock event occurs, a minimum digital lock event time can be calculated as "lock count" /  $f_{PDx}$  where X = 1 for PLL1 or 2 for PLL2.

By using [Equation 3](#), values for a "lock count" and "window size" can be chosen to set the frequency accuracy required by the system in ppm before the digital lock detect event occurs:

$$\text{ppm} = \frac{2e6 \times \text{PLLX\_WND\_SIZE} \times f_{PDx}}{\text{PLLX\_DLD\_CNT}} \quad (3)$$

The effect of the "lock count" value is that it shortens the effective lock window size by dividing the "window size" by "lock count".

If at any time the PLLX\_R reference and PLLX\_N feedback signals are outside the time window set by "window size", then the "lock count" value is reset to 0.

### 9.6.1 Minimum Lock Time Calculation Example

To calculate the minimum PLL2 digital lock time given a PLL2 phase detector frequency of 40 MHz and PLL2\_DLD\_CNT = 10,000. Then the minimum lock time of PLL2 will be 10,000 / 40 MHz = 250  $\mu$ s.

## 9.7 CALCULATING DYNAMIC DIGITAL DELAY VALUES FOR ANY DIVIDE

This section explains how to calculate the dynamic digital delay for any divide value.

Dynamic digital delay allows the time offset between two or more clock outputs to be adjusted with no or minimal interruption of clock outputs. Since the clock outputs are operating at a known frequency, the time offset can also be expressed as a phase shift. When dynamically adjusting the digital delay of clock outputs with different frequencies the phase shift should be expressed in terms of the higher frequency clock. The step size of the smallest time adjustment possible is equal to half the period of the Clock Distribution Path, which is the VCO frequency ([Equation 1](#)) or the VCO frequency divided by the VCO divider ([Equation 2](#)) if not bypassed. The smallest degree phase adjustment with respect to a clock frequency will be 360 \* the smallest time adjustment \* the clock frequency. The total number of phase offsets that the LMK04800 family is able to achieve using dynamic digital delay is equal 1 / (higher clock frequency \* the smallest phase adjustment).

[Equation 4](#) calculates the digital delay value that must be programmed for a synchronizing clock to achieve a 0 time/phase offset from the qualifying clock. Once this digital delay value is known, it is possible to calculate the digital delay value for any phase offset. The qualifying clock for dynamic digital delay is selected by the FEEDBACK\_MUX. When dynamic digital delay is engaged with same clock output used for the qualifying clock and the new synchronized clock, it is termed relative dynamic digital

delay since causing another SYNC event with the same digital delay value will offset the clock by the same phase once again. The important part of relative dynamic digital delay is that the CLKoutX\_Y\_HS must be programmed correctly when the SYNC event occurs (Table 7-8). This can result in needing to program the device twice. Once to set the new CLKoutX\_Y\_DDLY with CLKoutX\_Y\_HS as required for the SYNC event, and again to set the CLKoutX\_Y\_HS to its desired value.

Digital delay values are programmed using the CLKoutX\_Y\_DDLY and CLKoutX\_Y\_HS registers as shown in Equation 5. For example, to achieve a digital delay of 13.5, program CLKoutX\_Y\_DDLY = 14 and CLKoutX\_Y\_HS = 1.

$$0 \text{ digital delay} = \left( \left( \left\lceil \frac{16}{\text{CLKoutX\_Y\_DIV}} \right\rceil + 0.5 \right) \times \text{CLKoutX\_Y\_DIV} \right) - 11.5 \quad (4)$$

Equation 4 uses the ceiling operator. To find the ceiling of a fractional number round up. An integer remains the same value.

$$\text{Digital delay} = \text{CLKoutX\_Y\_DDLY} - (0.5 * \text{CLKoutX\_Y\_HS}) \quad (5)$$

Note: since the digital delay value for 0 time/phase offset is a function of the qualifying clock's divide value, the resulting digital delay value can be used for any clock output operating at any frequency to achieve a 0 time/phase offset from the qualifying clock. Therefore the calculated time shift table will also be the same as in Table 9-6.

### 9.7.1 Example

Consider a system with:

- A VCO frequency of 2000 MHz.
- The VCO divider is bypassed, therefore the clock distribution path frequency is 2000 MHz.
- CLKout0\_1\_DIV = 10 resulting in a 200 MHz frequency on CLKout0.
- CLKout2\_3\_DIV = 20 resulting in a 100 MHz frequency on CLKout2.

For this system the minimum time adjustment is 0.25 ns, which is 0.5 / (2000 MHz). Since the higher frequency is 200 MHz, phase adjustments will be calculated with respect to the 200 MHz frequency. The 0.25 ns minimum time adjustment results in a minimum phase adjustment of 18 degrees, which is 360 degrees / 200 MHz \* 0.25 ns.

To calculate the digital delay value to achieve a 0 time/phase shift of CLKout2 when CLKout0 is the qualifying clock. Solve Equation 4 using the divide value of 10. To solve the equation  $16/10 = 1.6$ , the ceiling of 1.6 is 2. Then to finish solving the equation solve  $(2 + 0.5) * 10 - 11.5 = 13.5$ . A digital delay value of 13.5 is programmed by setting CLKout2\_3\_DDLY = 14 and CLKout2\_3\_HS = 1.

To calculate the digital delay value to achieve a 0 time/phase shift of CLKout0 when CLKout2 is the qualifying clock, solve Equation 4 using the divide value of CLKout2, which is 20. This results in a digital delay of 18.5 which is programmed as CLKout0\_1\_DDLY = 19 and CLKout0\_1\_HS = 1.

Once the 0 time/phase shift digital delay programming value is known a table can be constructed with the digital delay value to be programmed for any time/phase offset by decrementing or incrementing the digital delay value by 0.5 for the minimum time/phase adjustment.

A complete filled out table for use of CLKout0 as the qualifying clock is shown in Table 9-6. It was created by entering a digital delay of 13.5 for 0 degree phase shift, then decrementing the digital delay down to the minimum value of 4.5. Since this did not result in all the possible phase shifts, the digital delay was then incremented from 13.5 to 14.0 to complete all possible phase shifts.

**Table 9-6. Example Digital Delay Calculation**

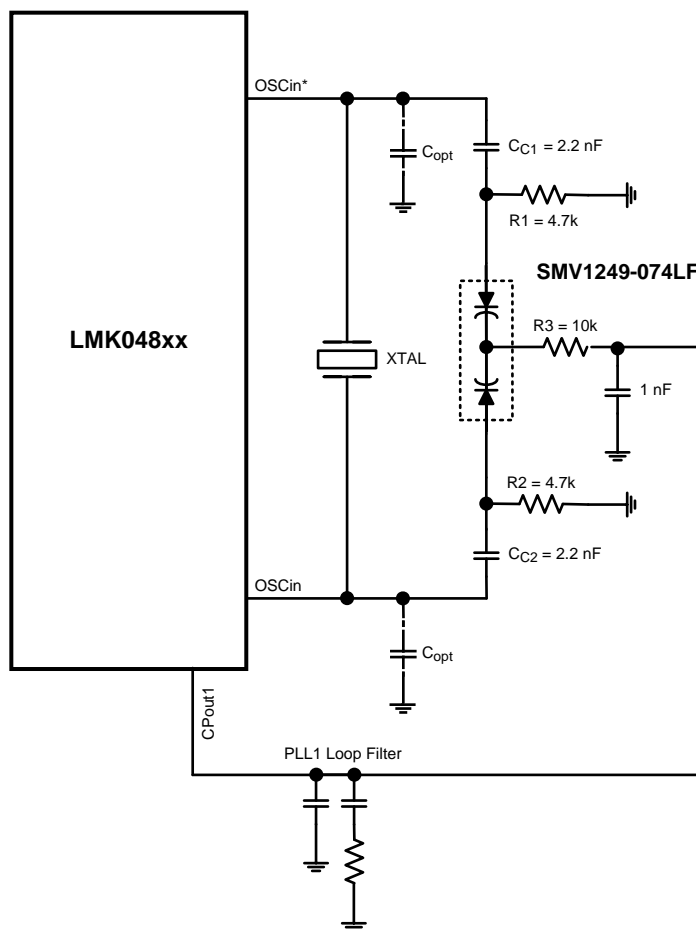
| Digital delay | Calculated time shift (ns) | Relative time shift to 200 MHz (ns) | Phase shift of 200 MHz (degrees) |
|---------------|----------------------------|-------------------------------------|----------------------------------|
| 4.5           | -4.5                       | 0.5                                 | 36                               |
| 5             | -4.25                      | 0.75                                | 54                               |
| 5.5           | -4.0                       | 1.0                                 | 72                               |
| 6             | -3.75                      | 1.25                                | 90                               |
| 6.5           | -3.5                       | 1.5                                 | 108                              |
| 7             | -3.25                      | 1.75                                | 126                              |
| 7.5           | -3.0                       | 2.0                                 | 144                              |
| 8             | -2.75                      | 2.25                                | 162                              |
| 8.5           | -2.5                       | 2.5                                 | 180                              |
| 9             | -2.25                      | 2.75                                | 198                              |
| 9.5           | -2.0                       | 3.0                                 | 216                              |
| 10            | -1.75                      | 3.25                                | 234                              |
| 10.5          | -1.5                       | 3.5                                 | 252                              |
| 11            | -1.25                      | 3.75                                | 270                              |
| 11.5          | -1.0                       | 4.0                                 | 288                              |
| 12            | -0.75                      | 4.25                                | 306                              |
| 12.5          | -0.5                       | 4.5                                 | 324                              |
| 13            | -0.25                      | 4.75                                | 342                              |
| <b>13.5</b>   | <b>0</b>                   | <b>0</b>                            | <b>0</b>                         |
| 14            | 0.25                       | 0.25                                | 18                               |
| 14.5          | 0.5                        | 0.5                                 | 36                               |

Observe that the digital delay value of 4.5 and 14.5 will achieve the same relative time shift/phase delay. However programming a digital delay of 14.5 will result in a clock off time for the synchronizing clock to achieve the same phase time shift/phase delay.

Digital delay value is programmed as  $\text{CLKoutX\_Y\_DDL Y} - (0.5 * \text{CLKoutX\_Y\_HS})$ . So to achieve a digital delay of 13.5, program  $\text{CLKoutX\_Y\_DDL Y} = 14$  and  $\text{CLKoutX\_Y\_HS} = 1$ . To achieve a digital delay of 14, program  $\text{CLKoutX\_Y\_DDL Y} = 14$  and  $\text{CLKoutX\_Y\_HS} = 0$ .

## 9.8 OPTIONAL CRYSTAL OSCILLATOR IMPLEMENTATION (OSCin/OSCin\*)

The LMK04800 family features supporting circuitry for a discretely implemented oscillator driving the OSCin port pins. Figure 9-4 illustrates a reference design circuit for a crystal oscillator:



**Figure 9-4. Reference Design Circuit for Crystal Oscillator Option**

This circuit topology represents a parallel resonant mode oscillator design. When selecting a crystal for parallel resonance, the total load capacitance,  $C_L$ , must be specified. The load capacitance is the sum of the tuning capacitance ( $C_{TUNE}$ ), the capacitance seen looking into the OSCin port ( $C_{IN}$ ), and stray capacitance due to PCB parasitics ( $C_{STRAY}$ ), and is given by Equation 6.

$$C_L = C_{TUNE} + C_{IN} + \frac{C_{STRAY}}{2} \quad (6)$$

$C_{TUNE}$  is provided by the varactor diode shown in Figure 9-4, Skyworks model SMV1249-074LF. A dual diode package with common cathode provides the variable capacitance for tuning. The single diode capacitance ranges from approximately 31 pF at 0.3 V to 3.4 pF at 3 V. The capacitance range of the dual package (anode to anode) is approximately 15.5 pF at 3 V to 1.7 pF at 0.3 V. The desired value of  $V_{TUNE}$  applied to the diode should be  $V_{CC}/2$ , or 1.65 V for  $V_{CC} = 3.3$  V. The typical performance curve from the data sheet for the SMV1249-074LF indicates that the capacitance at this voltage is approximately 6 pF ( $12 \text{ pF} / 2$ ).

The nominal input capacitance ( $C_{IN}$ ) of the LMK04800 family OSCin pins is 6 pF. The stray capacitance ( $C_{STRAY}$ ) of the PCB should be minimized by arranging the oscillator circuit layout to achieve trace lengths as short as possible and as narrow as possible trace width (50  $\Omega$  characteristic impedance is not required). As an example, assume that  $C_{STRAY}$  is 4 pF. The total load capacitance is nominally:

$$C_L = 6 + 6 + \frac{4}{2} = 14 \text{ pF} \quad (7)$$

Consequently the load capacitance specification for the crystal in this case should be nominally 14 pF.

The 2.2 nF capacitors shown in the circuit are coupling capacitors that block the DC tuning voltage applied by the 4.7 k $\Omega$  and 10 k $\Omega$  resistors. The value of these coupling capacitors should be large, relative to the value of  $C_{TUNE}$  ( $C_{C1} = C_{C2} \gg C_{TUNE}$ ), so that  $C_{TUNE}$  becomes the dominant capacitance.

For a specific value of  $C_L$ , the corresponding resonant frequency ( $F_L$ ) of the parallel resonant mode circuit is:

$$F_L = F_S \cdot \left\{ \frac{C_1}{2(C_0 + C_{L1})} + 1 \right\} = F_S \cdot \left\{ 2 \left( \frac{1}{\left( \frac{C_0}{C_1} + \frac{C_L}{C_1} \right)} + 1 \right) \right\}$$

where

- $F_S$  = Series resonant frequency
  - $C_1$  = Motional capacitance of the crystal
  - $C_L$  = Load capacitance
  - $C_0$  = Shunt capacitance of the crystal, specified on the crystal datasheet
- (8)

The normalized tuning range of the circuit is closely approximated by:

$$\frac{\Delta F}{F} = \frac{F_{CL1} - F_{CL2}}{F_{FCL1}} = \frac{C_1}{2} \cdot \left\{ \frac{1}{(C_0 + C_{L1})} - \frac{1}{(C_0 + C_{L2})} \right\} = \frac{1}{2} \cdot \left\{ \frac{1}{\left( \frac{C_0}{C_1} + \frac{C_{L1}}{C_1} \right)} - \frac{1}{\left( \frac{C_0}{C_1} + \frac{C_{L2}}{C_1} \right)} \right\} \quad (9)$$

$C_{L1}$ ,  $C_{L2}$  = The endpoints of the circuit's load capacitance range, assuming a variable capacitance element is one component of the load.  $F_{CL1}$ ,  $F_{CL2}$  = parallel resonant frequencies at the extremes of the circuit's load capacitance range.

A common range for the pullability ratio,  $C_0/C_1$ , is 250 to 280. The ratio of the load capacitance to the shunt capacitance is  $\sim(n * 1000)$ ,  $n < 10$ . Hence, picking a crystal with a smaller pullability ratio supports a wider tuning range because this allows the scale factors related to the load capacitance to dominate.

Examples of the phase noise and jitter performance of the LMK04808 with a crystal oscillator are shown in [Table 9-7](#). This table illustrates the clock output phase noise when a 20.48 MHz crystal is paired with PLL1.



**Table 9-7. Example RMS Jitter and Clock Output Phase Noise for LMK04800 with a 20.48 MHz Crystal Driving OSCin (T = 25 °C, V<sub>CC</sub> = 3.3 V) <sup>(1)</sup>**

|                       |                            | RMS Jitter (ps)  |   |                               |
|-----------------------|----------------------------|--|---|-------------------------------|
| Integration Bandwidth | Clock Output Type          | PLL2 PDF = 20.48 MHz<br>(EN_PLL2_REF2X = 0,<br>XTAL_LVL = 3) | PLL2 PDF = 40.96 MHz<br>(EN_PLL2_REF2X = 1, XTAL_LVL = 3) |                               |
|                       |                            | f <sub>CLK</sub> = 245.76 MHz                                | f <sub>CLK</sub> = 122.88 MHz                             | f <sub>CLK</sub> = 245.76 MHz |
| 100 Hz – 20 MHz       | LVC MOS                    | 374  | 412   | 382                           |
|                       | LVDS                       | 419  | 421   | 372                           |
|                       | LVPECL 1.6 V <sub>pp</sub> | 460  | 448   | 440                           |
| 10 kHz – 20 MHz       | LVC MOS                    | 226  | 195   | 190                           |
|                       | LVDS                       | 231  | 205   | 194                           |
|                       | LVPECL 1.6 V <sub>pp</sub> | 226  | 191   | 188                           |
|                       |                            | Phase Noise (dBc/Hz)   |   |                               |
| Offset                | Clock Output Type          | PLL2 PDF = 20.48 MHz<br>(EN_PLL2_REF2X = 0,<br>XTAL_LVL = 3) | PLL2 PDF = 40.96 MHz<br>(EN_PLL2_REF2X = 1, XTAL_LVL = 3) |                               |
|                       |                            | f <sub>CLK</sub> = 245.76 MHz                                | f <sub>CLK</sub> = 122.88 MHz                             | f <sub>CLK</sub> = 245.76 MHz |
| 100 Hz                | LVC MOS                    | -87  | -93   | -87                           |
|                       | LVDS                       | -86  | -91   | -86                           |
|                       | LVPECL 1.6 V <sub>pp</sub> | -86  | -92   | -85                           |
| 1 kHz                 | LVC MOS                    | -115   | -121  | -115                          |
|                       | LVDS                       | -115   | -123  | -116                          |
|                       | LVPECL 1.6 V <sub>pp</sub> | -114   | -122  | -116                          |
| 10 kHz                | LVC MOS                    | -117   | -128  | -122                          |
|                       | LVDS                       | -117   | -128  | -122                          |
|                       | LVPECL 1.6 V <sub>pp</sub> | -117   | -128  | -122                          |
| 100 kHz               | LVC MOS                    | -130   | -135  | -129                          |
|                       | LVDS                       | -130   | -135  | -129                          |
|                       | LVPECL 1.6 V <sub>pp</sub> | -129   | -135  | -129                          |
| 1 MHz                 | LVC MOS                    | -150   | -154  | -148                          |
|                       | LVDS                       | -149   | -153  | -148                          |
|                       | LVPECL 1.6 V <sub>pp</sub> | -150   | -154  | -148                          |
| 40 MHz                | LVC MOS                    | -159   | -162  | -159                          |
|                       | LVDS                       | -157   | -159  | -157                          |
|                       | LVPECL 1.6 V <sub>pp</sub> | -159   | -161  | -159                          |

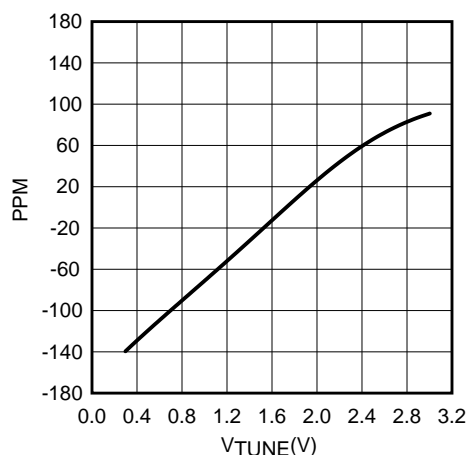
(1) Performance data and crystal specifications contained in this section are based on Vectron model VXB1-1150-20M480, 20.48 MHz. PLL1 has a narrow loop bandwidth, PLL2 loop parameters are: C1 = 150 pF, C2 = 120 nF, R2 = 470 Ω, Charge Pump current = 3.2 mA, Phase detector frequency = 20.48 MHz or 40.96 MHz, VCO frequency = 2949.12 MHz. Loop filter was optimized for 40.96 MHz phase detector performance.

Example crystal specifications are presented in [Table 9-8](#).

**Table 9-8. Example Crystal Specifications**

| Parameter                              | Value                    |
|--|--------------------------|
| Nominal Frequency (MHz)                | 20.48                    |
| Frequency Stability, T = 25 °C         | ± 10 ppm                 |
| Operating temperature range            | -40 °C to +85 °C         |
| Frequency Stability, -40 °C to +85 °C  | ± 15 ppm                 |
| Load Capacitance                       | 14 pF                    |
| Shunt Capacitance (C <sub>0</sub> )    | 5 pF Maximum             |
| Motional Capacitance (C <sub>1</sub> ) | 20 fF ± 30%              |
| Equivalent Series Resistance           | 25 Ω Maximum             |
| Drive level                            | 2 mWatts Maximum         |
| C <sub>0</sub> /C <sub>1</sub> ratio   | 225 typical, 250 Maximum |

See [Figure 9-5](#) for a representative tuning curve.



**Figure 9-5. Example Tuning Curve, 20.48 MHz Crystal**

The tuning curve achieved in the user's application may differ from the curve shown above due to differences in PCB layout and component selection.

This data is measured on the bench with the crystal integrated with the LMK04800 family. Using a voltmeter to monitor the  $V_{TUNE}$  node for the crystal, the PLL1 reference clock input frequency is swept in frequency and the resulting tuning voltage generated by PLL1 is measured at each frequency. At each value of the reference clock frequency, the lock state of PLL1 should be monitored to ensure that the tuning voltage applied to the crystal is valid.

The curve shows over the tuning voltage range of 0.3 VDC to 3.0 VDC, the frequency range is -140 to +91 ppm; or equivalently, a tuning range of -2850 Hz to +1850 Hz. The measured tuning voltage at the nominal crystal frequency (20.48 MHz) is 1.7 V. Using the diode data sheet tuning characteristics, this voltage results in a tuning capacitance of approximately 6.5 pF.

The tuning curve data can be used to calculate the gain of the oscillator ( $K_{VCO}$ ). The data used in the calculations is taken from the most linear portion of the curve, a region centered on the crossover point at the nominal frequency (20.48 MHz). For a well designed circuit, this is the most likely operating range. In this case, the tuning range used for the calculations is  $\pm 1000$  Hz ( $\pm 0.001$  MHz), or  $\pm 81.4$  ppm. The simplest method is to calculate the ratio:

$$K_{VCO} = \frac{\Delta F}{\Delta V} = \left( \frac{\Delta F_2 - \Delta F_1}{V_{TUNE2} - V_{TUNE1}} \right), \frac{\text{MHz}}{\text{V}} \quad (10)$$

$\Delta F_2$  and  $\Delta F_1$  are in units of MHz. Using data from the curve this becomes:

$$\frac{0.001 - (-0.001)}{2.03 - 0.814} = 0.00164 \frac{\text{MHz}}{\text{V}} \quad (11)$$

A second method uses the tuning data in units of ppm:

$$K_{VCO} = \frac{F_{NOM} \cdot (\Delta \text{ppm}_2 - \Delta \text{ppm}_1)}{\Delta V \cdot 10^6} \quad (12)$$

$F_{NOM}$  is the nominal frequency of the crystal and is in units of MHz. Using the data, this becomes:

$$\frac{12.288 \cdot (81.4 - (-81.4))}{(2.03 - 0.814) \cdot 10^6} = 0.00164, \frac{\text{MHz}}{\text{V}} \quad (13)$$

In order to ensure startup of the oscillator circuit, the equivalent series resistance (ESR) of the selected crystal should conform to the specifications listed in the table of Electrical Characteristics.

It is also important to select a crystal with adequate power dissipation capability, or *drive level*. If the drive level supplied by the oscillator exceeds the maximum specified by the crystal manufacturer, the crystal will undergo excessive aging and possibly become damaged. Drive level is directly proportional to resonant frequency, capacitive load seen by the crystal, voltage and equivalent series resistance (ESR). For more complete coverage of crystal oscillator design, see Application Note AN-1939 at

<http://www.ti.com/lscs/ti/analog/clocksandtimers/tools.page>

or

<http://www.ti.com/lit/SNAA065>.

## 9.9 DRIVING CLKin AND OSCin INPUTS

### 9.9.1 Driving CLKin Pins with a Differential Source

Both CLKin ports can be driven by differential signals. It is recommended that the input mode be set to bipolar (CLKinX\_BUF\_TYPE = 0) when using differential reference clocks. The LMK04800 family internally biases the input pins so the differential interface should be AC coupled. The recommended circuits for driving the CLKin pins with either LVDS or LVPECL are shown in Figure 9-6 and Figure 9-7.

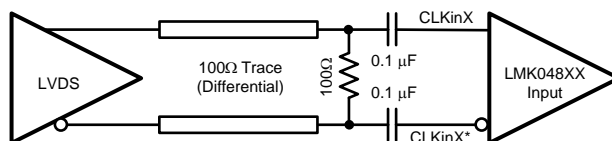


Figure 9-6. CLKinX/X\* Termination for an LVDS Reference Clock Source

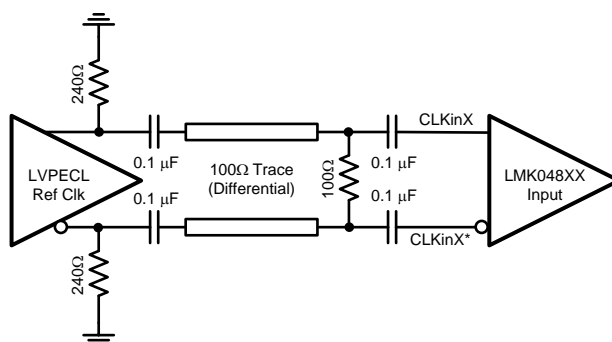


Figure 9-7. CLKinX/X\* Termination for an LVPECL Reference Clock Source

Finally, a reference clock source that produces a differential sine wave output can drive the CLKin pins using the following circuit. Note: the signal level must conform to the requirements for the CLKin pins listed in the Electrical Characteristics table.

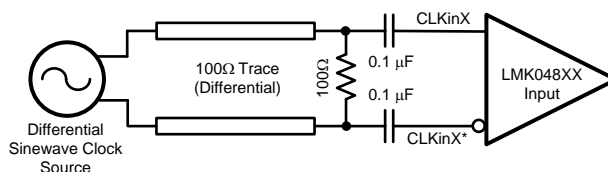


Figure 9-8. CLKinX/X\* Termination for a Differential Sinewave Reference Clock Source

### 9.9.2 Driving CLKin Pins with a Single-Ended Source

The CLKin pins of the LMK04800 family can be driven using a single-ended reference clock source, for example, either a sine wave source or an LVCMOS/LVTTL source. Either AC coupling or DC coupling may be used. In the case of the sine wave source that is expecting a 50 Ω load, it is recommended that AC coupling be used as shown in the circuit below with a 50 Ω termination.

#### NOTE

The signal level must conform to the requirements for the CLKin pins listed in the Electrical Characteristics table. CLKinX\_BUF\_TYPE in Register 11 is recommended to be set to bipolar mode (CLKinX\_BUF\_TYPE = 0).

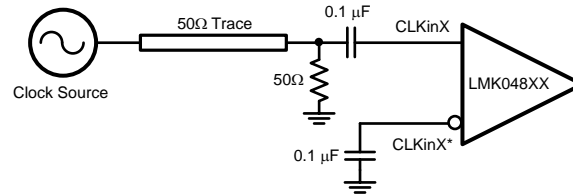


Figure 9-9. CLKInX/X\* Single-ended Termination

If the CLKIn pins are being driven with a single-ended LVCMOS/LVTTL source, either DC coupling or AC coupling may be used. If DC coupling is used, the CLKInX\_BUF\_TYPE should be set to MOS buffer mode (CLKInX\_BUF\_TYPE = 1) and the voltage swing of the source must meet the specifications for DC coupled, MOS-mode clock inputs given in the table of Electrical Characteristics. If AC coupling is used, the CLKInX\_BUF\_TYPE should be set to the bipolar buffer mode (CLKInX\_BUF\_TYPE = 0). The voltage swing at the input pins must meet the specifications for AC coupled, bipolar mode clock inputs given in the table of Electrical Characteristics. In this case, some attenuation of the clock input level may be required. A simple resistive divider circuit before the AC coupling capacitor is sufficient.

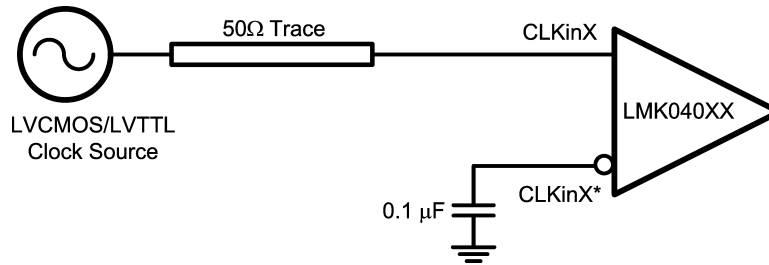


Figure 9-10. DC Coupled LVCMOS/LVTTL Reference Clock

## 9.10 TERMINATION AND USE OF CLOCK OUTPUT (DRIVERS)

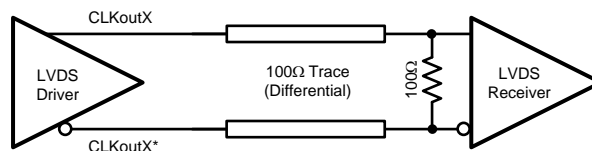
When terminating clock drivers keep in mind these guidelines for optimum phase noise and jitter performance:

- Transmission line theory should be followed for good impedance matching to prevent reflections.
- Clock drivers should be presented with the proper loads. For example:
  - LVDS drivers are current drivers and require a closed current loop.
  - LVPECL drivers are open emitters and require a DC path to ground.
- Receivers should be presented with a signal biased to their specified DC bias level (common mode voltage) for proper operation. Some receivers have self-biasing inputs that automatically bias to the proper voltage level. In this case, the signal should normally be AC coupled.

It is possible to drive a non-LVPECL or non-LVDS receiver with an LVDS or LVPECL driver as long as the above guidelines are followed. Check the datasheet of the receiver or input being driven to determine the best termination and coupling method to be sure that the receiver is biased at its optimum DC voltage (common mode voltage). For example, when driving the OSCin/OSCin\* input of the LMK04800 family, OSCin/OSCin\* should be AC coupled because OSCin/OSCin\* biases the signal to the proper DC level (See Figure 9-2) This is only slightly different from the AC coupled cases described in Section 9.9.2 because the DC blocking capacitors are placed between the termination and the OSCin/OSCin\* pins, but the concept remains the same. The receiver (OSCin/OSCin\*) sets the input to the optimum DC bias voltage (common mode voltage), not the driver.

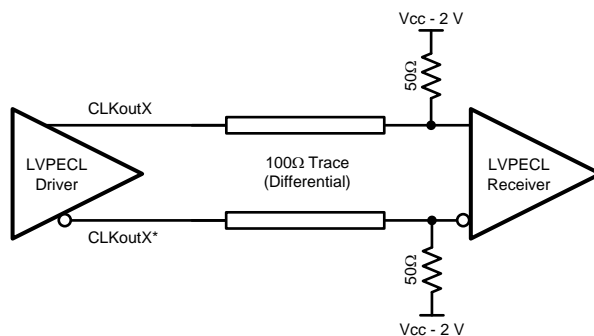
### 9.10.1 Termination for DC Coupled Differential Operation

For DC coupled operation of an LVDS driver, terminate with  $100\ \Omega$  as close as possible to the LVDS receiver as shown in Figure 9-11.

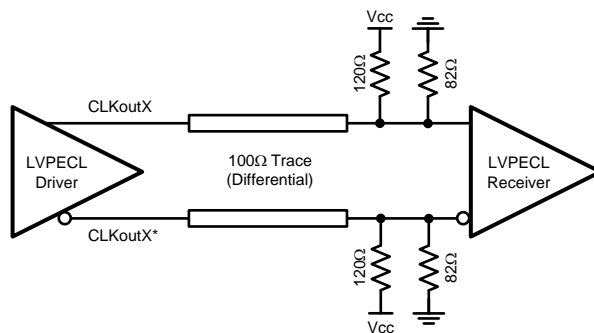


**Figure 9-11. Differential LVDS Operation, DC Coupling, No Biasing of the Receiver**

For DC coupled operation of an LVPECL driver, terminate with  $50\ \Omega$  to  $V_{CC} - 2\text{ V}$  as shown in Figure 9-12. Alternatively terminate with a Thevenin equivalent circuit ( $120\ \Omega$  resistor connected to  $V_{CC}$  and an  $82\ \Omega$  resistor connected to ground with the driver connected to the junction of the  $120\ \Omega$  and  $82\ \Omega$  resistors) as shown in Figure 9-13 for  $V_{CC} = 3.3\text{ V}$ .



**Figure 9-12. Differential LVPECL Operation, DC Coupling**

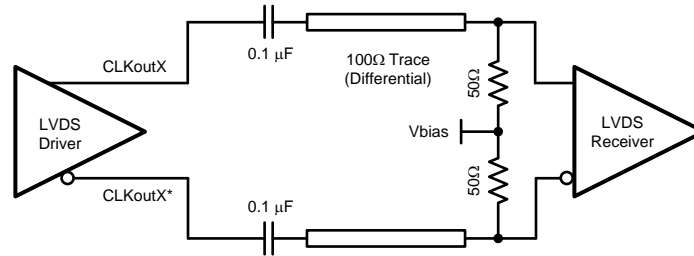


**Figure 9-13. Differential LVPECL Operation, DC Coupling, Thevenin Equivalent**

### 9.10.2 Termination for AC Coupled Differential Operation

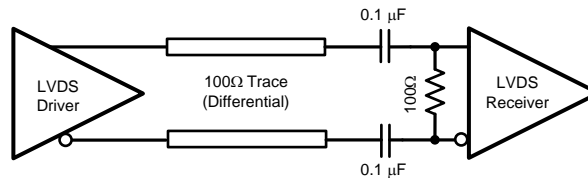
AC coupling allows for shifting the DC bias level (common mode voltage) when driving different receiver standards. Since AC coupling prevents the driver from providing a DC bias voltage at the receiver it is important to ensure the receiver is biased to its ideal DC level.

When driving non-biased LVDS receivers with an LVDS driver, the signal may be AC coupled by adding DC blocking capacitors, however the proper DC bias point needs to be established at the receiver. One way to do this is with the termination circuitry in Figure 9-14.



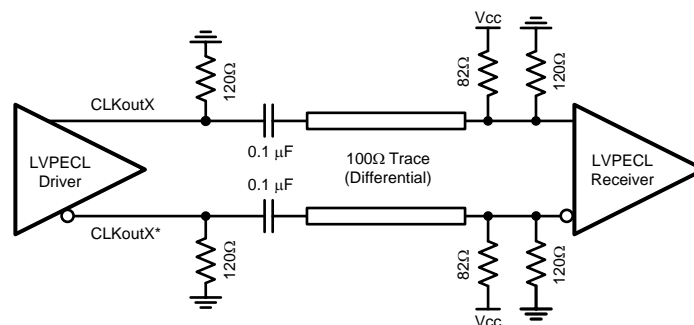
**Figure 9-14. Differential LVDS Operation, AC Coupling, External Biasing at the Receiver**

Some LVDS receivers may have internal biasing on the inputs. In this case, the circuit shown in [Figure 9-14](#) is modified by replacing the 50 Ω terminations to Vbias with a single 100 Ω resistor across the input pins of the receiver, as shown in [Figure 9-15](#). When using AC coupling with LVDS outputs, there may be a startup delay observed in the clock output due to capacitor charging. The previous figures employ a 0.1 μF capacitor. This value may need to be adjusted to meet the startup requirements for a particular application.



**Figure 9-15. LVDS Termination for a Self-Biased Receiver**

LVPECL drivers require a DC path to ground. When AC coupling an LVPECL signal use 120 Ω emitter resistors close to the LVPECL driver to provide a DC path to ground as shown in [Figure 9-16](#). For proper receiver operation, the signal should be biased to the DC bias level (common mode voltage) specified by the receiver. The typical DC bias voltage for LVPECL receivers is 2 V. A Thevenin equivalent circuit (82 Ω resistor connected to V<sub>CC</sub> and a 120 Ω resistor connected to ground with the driver connected to the junction of the 82 Ω and 120 Ω resistors) is a valid termination as shown in [Figure 9-16](#) for V<sub>CC</sub> = 3.3 V. Note this Thevenin circuit is different from the DC coupled example in [Figure 9-13](#).



**Figure 9-16. Differential LVPECL Operation, AC Coupling, Thevenin Equivalent, External Biasing at the Receiver**

### 9.10.3 Termination for Single-Ended Operation

A balun can be used with either LVDS or LVPECL drivers to convert the balanced, differential signal into an unbalanced, single-ended signal.

It is possible to use an LVPECL driver as one or two separate 800 mVpp signals. When using only one LVPECL driver of a CLKoutX/CLKoutX\* pair, be sure to properly terminate the unused driver. When DC coupling one of the LMK04800 family clock LVPECL drivers, the termination should be  $50\ \Omega$  to  $V_{CC} - 2\ V$  as shown in Figure 9-17. The Thevenin equivalent circuit is also a valid termination as shown in Figure 9-18 for  $V_{CC} = 3.3\ V$ .

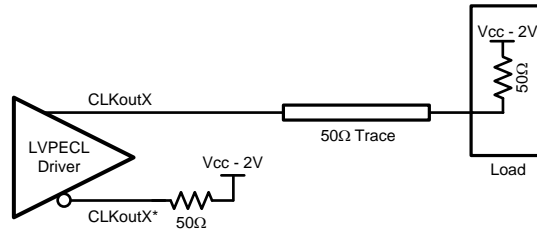


Figure 9-17. Single-Ended LVPECL Operation, DC Coupling

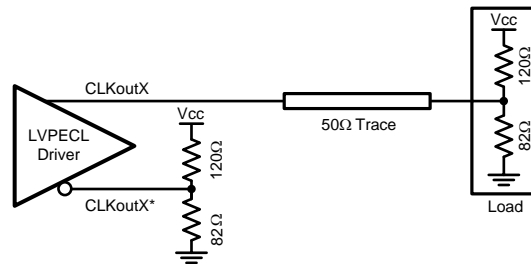


Figure 9-18. Single-Ended LVPECL Operation, DC Coupling, Thevenin Equivalent

When AC coupling an LVPECL driver use a  $120\ \Omega$  emitter resistor to provide a DC path to ground and ensure a  $50\ \Omega$  termination with the proper DC bias level for the receiver. The typical DC bias voltage for LVPECL receivers is  $2\ V$  (See Section 9.9.2). If the companion driver is not used it should be terminated with either a proper AC or DC termination. This latter example of AC coupling a single-ended LVPECL signal can be used to measure single-ended LVPECL performance using a spectrum analyzer or phase noise analyzer. When using most RF test equipment no DC bias point ( $0\ V_{DC}$ ) is required for safe and proper operation. The internal  $50\ \Omega$  termination of the test equipment correctly terminates the LVPECL driver being measured as shown in Figure 9-19.

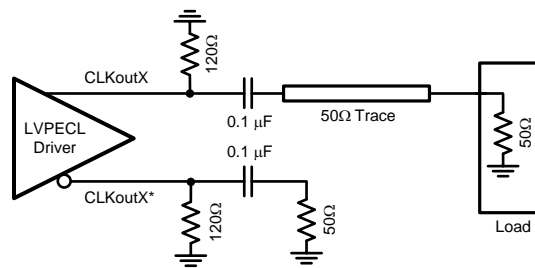


Figure 9-19. Single-Ended LVPECL Operation, AC Coupling



## 9.11 POWER SUPPLY

### 9.11.1 Current Consumption / Power Dissipation Calculations

From [Table 9-9](#) the current consumption can be calculated for any configuration.

For example, the current for the entire device with 1 LVDS (CLKout0) and 1 LVPECL 1.6 Vpp /w 240 ohm emitter resistors (CLKout1) output active with a clock output divide = 1, and no other features enabled can be calculated by adding up the following blocks: core current, clock buffer, one LVDS output buffer current, and one LVPECL output buffer current. There will also be one LVPECL output drawing emitter current, which means some of the power from the current draw of the device is dissipated in the external emitter resistors which doesn't add to the power dissipation budget for the device but is important for LDO I<sub>CC</sub> calculations.

For total current consumption of the device, add up the significant functional blocks. In this example, 228.1 mA =

- 140 mA (core current)
- 17.3 mA (base clock distribution)
- 25.5 mA (CLKout0 & 1 divider)
- 14.3 mA (LVDS buffer)
- 31 mA (LVPECL 1.6 Vpp buffer /w 240 ohm emitter resistors)

Once total current consumption has been calculated, power dissipated by the device can be calculated. The power dissipation of the device is equation to the total current entering the device multiplied by the voltage at the device minus the power dissipated in any emitter resistors connected to any of the LVPECL outputs. If no emitter resistors are connected to the LVPECL outputs, this power will be 0 watts. Continuing the above example which has 228.1 mA total I<sub>CC</sub> and one output with 240 ohm emitter resistors. Total IC power = 717.7 mW = 3.3 V \* 228.1 mA - 35 mW.

**Table 9-9. Typical Current Consumption for Selected Functional Blocks**  
( $T_A = 25\text{ }^\circ\text{C}$ ,  $V_{CC} = 3.3\text{ V}$ )

| Block                             | Condition   | Typical $I_{CC}$ (mA)                              | Power dissipated in device (mW) | Power dissipated externally <sup>(1)</sup><br><sup>(2)</sup> <sup>(3)</sup> (mW) |   |
|-----------------------------------|---|--|---------------------------------|--|---|
| <b>Core and Functional Blocks</b> |   |  |                                 |  |   |
| Core                              | MODE = 0: Dual Loop, Internal VCO   | PLL1 and PLL2 locked                               | 140                             | 462  | - |
|                                   | MODE = 2: Dual Loop, Internal VCO, 0-Delay  | PLL1 and PLL2 locked; Includes EN_FEEDBACK_MUX = 1 | 155                             | 512  | - |
|                                   | MODE = 3: Dual Loop, External VCO   | PLL1 and PLL2 locked                               | 127                             | 419  | - |
|                                   | MODE = 5: Dual Loop, External VCO, 0-Delay  | PLL1 and PLL2 locked; Includes EN_FEEDBACK_MUX = 1 | 142                             | 469  | - |
|                                   | MODE = 6: Single Loop (PLL2), Internal VCO  | PLL2 locked  | 116                             | 383  | - |
|                                   | MODE = 11: Single Loop (PLL2), External VCO   | PLL2 locked  | 103                             | 340  | - |
|                                   | MODE = 16: Clock Distribution   | PD_OSCin = 0                                       | 42                              | 139  | - |
| PD_OSCin = 1                      |   | 34.5   | 114                             | -  |   |
| EN_TRACK                          | Tracking is enabled (EN_TRACK = 1)  | 2  | 6.6                             | -  |   |
| Base Clock Distribution           | At least 1 CLKoutX_Y_PD = 0   | 17.3   | 57.1                            | -  |   |
| CLKout Group                      | Each CLKout group (CLKout0/1 & 10/11, CLKout2/3 & 4/5, CLKout 6/7 & 8/9)                | 2.8  | 9.2                             | -  |   |
| Clock Divider/<br>Digital Delay   | When a clock output is enabled, this contributes the divider/delay block                | 25.5   | 84.1                            | -  |   |
|                                   | Divider / digital delay in <b>extended</b> mode   | 29.6   | 97.7                            | -  |   |
| VCO Divider                       | VCO Divider current   | 7.7  | 25.4                            | -  |   |
| HOLDOVER mode                     | When in holdover mode   | 2.2  | 7.2                             | -  |   |
| Feedback Mux                      | Feedback mux must be enabled for 0-delay modes and digital delay mode (SYNC_QUAL = 1)   | 4.9  | 16.1                            | -  |   |
| SYNC Asserted                     | While SYNC is asserted, this extra current is drawn                                     | 1.7  | 5.6                             | -  |   |
| EN_SYNC = 1                       | Required for SYNC functionality. May be turned off once SYNC is complete to save power. | 6  | 19.8                            | -  |   |
| SYNC_QUAL = 1                     | Delay enabled, delay > 7 (CLKout_MUX = 2, 3)  | 8.7  | 28.7                            | -  |   |
| Crystal Mode                      | Enabling the Crystal Oscillator   | XTAL_LVL = 0                                       | 1.8                             | 5.9  | - |
|                                   |   | XTAL_LVL = 1                                       | 2.7                             | 9  | - |
|                                   |   | XTAL_LVL = 2                                       | 3.6                             | 12   | - |
|                                   |   | XTAL_LVL = 3                                       | 4.5                             | 15   | - |
| OSCin Doubler                     | EN_PLL2_REF_2X = 1  | 2.8  | 9.2                             | -  |   |

- (1) Power is dissipated externally in LVPECL emitter resistors. The externally dissipated power is calculated as twice the DC voltage level of one LVPECL clock output pin squared over the emitter resistance. That is to say power dissipated in emitter resistors =  $2 * V_{em}^2 / R_{em}$ .
- (2) Assuming  $\theta_{JA} = 15\text{ }^\circ\text{C/W}$ , the total power dissipated on chip must be less than  $(125\text{ }^\circ\text{C} - 85\text{ }^\circ\text{C}) / 16\text{ }^\circ\text{C/W} = 2.5\text{ W}$  to ensure a junction temperature is less than  $125\text{ }^\circ\text{C}$ .
- (3) Worst case power dissipation can be estimated by multiplying typical power dissipation with a factor of 1.15.

**Table 9-9. Typical Current Consumption for Selected Functional Blocks  
(T<sub>A</sub> = 25 °C, V<sub>CC</sub> = 3.3 V) (continued)**

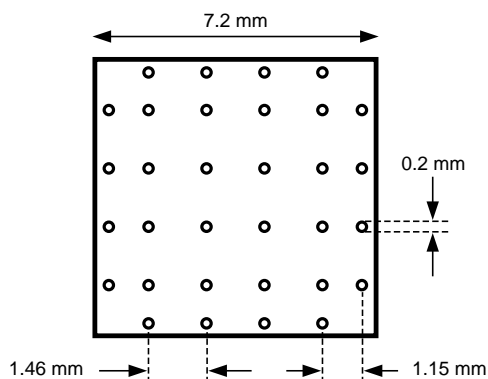
| Block                       | Condition   | Typical I <sub>CC</sub><br>(mA) | Power<br>dissipated in<br>device<br>(mW) | Power<br>dissipated<br>externally <sup>(1)</sup><br>(2) (3)<br>(mW) |   |
|-----------------------------|---|---------------------------------|--|---|---|
| Analog Delay                | Analog Delay Value  | CLKoutX_Y_ANLG_DLY = 0 to 3     | 3.4                                      | 11.2  | - |
|                             |   | CLKoutX_Y_ANLG_DLY = 4 to 7     | 3.8                                      | 12.5  | - |
|                             |   | CLKoutX_Y_ANLG_DLY = 8 to 11    | 4.2                                      | 13.9  | - |
|                             |   | CLKoutX_Y_ANLG_DLY = 12 to 15   | 4.7                                      | 15.5  | - |
|                             |   | CLKoutX_Y_ANLG_DLY = 16 to 23   | 5.2                                      | 17.2  | - |
|                             | Only Single Output Of Clock Pair Has Analog Delay Selected. Example: CLKout0_ADLY_SEL = 1 and CLKout1_ADLY_SEL = 0, or CLKout0_ADLY_SEL = 0 and CLKout1_ADLY_SEL = 1. |                                 | 2.8                                      | 9.2   | - |
| <b>Clock Output Buffers</b> |   |                                 |  |   |   |
| LVDS                        | 100 ohm differential termination  | 14.3                            | 47.2                                     | -   |   |
| LVPECL                      | LVPECL 2.0 Vpp, AC coupled using 240 ohm emitter resistors  | 32                              | 70.6                                     | 35  |   |
|                             | LVPECL 1.6 Vpp, AC coupled using 240 ohm emitter resistors  | 31                              | 67.3                                     | 35  |   |
|                             | LVPECL 1.6 Vpp, AC coupled using 120 ohm emitter resistors  | 46                              | 91.8                                     | 60  |   |
|                             | LVPECL 1.2 Vpp, AC coupled using 240 ohm emitter resistors  | 30                              | 59                                       | 40  |   |
|                             | LVPECL 0.7 Vpp, AC coupled using 240 ohm emitter resistors  | 29                              | 55.7                                     | 40  |   |
| LVCMOS                      | LVCMOS Pair (CLKoutX_TYPE = 6 to 9)<br>C <sub>L</sub> = 5 pF  | 3 MHz                           | 24                                       | 79.2  | - |
|                             |   | 30 MHz                          | 26.5                                     | 87.5  | - |
|                             |   | 150 MHz                         | 36.5                                     | 120.5   | - |
|                             | LVCMOS Single (CLKoutX_TYPE = 10 to 13)<br>C <sub>L</sub> = 5 pF  | 3 MHz                           | 15                                       | 49.5  | - |
|                             |   | 30 MHz                          | 16                                       | 52.8  | - |
|                             |   | 150 MHz                         | 21.5                                     | 71  | - |

## 9.12 THERMAL MANAGEMENT

Power consumption of the LMK04800 family of devices can be high enough to require attention to thermal management. For reliability and performance reasons the die temperature should be limited to a maximum of 125 °C. That is, as an estimate,  $T_A$  (ambient temperature) plus device power consumption times  $\theta_{JA}$  should not exceed 125 °C.

The package of the device has an exposed pad that provides the primary heat removal path as well as excellent electrical grounding to a printed circuit board. To maximize the removal of heat from the package a thermal land pattern including multiple vias to a ground plane must be incorporated on the PCB within the footprint of the package. The exposed pad must be soldered down to ensure adequate heat conduction out of the package.

A recommended land and via pattern is shown in [Figure 9-20](#). More information on soldering WQFN packages can be obtained: [www.ti.com/packaging/](http://www.ti.com/packaging/).



**Figure 9-20. Recommended Land and Via Pattern**

To minimize junction temperature it is recommended that a simple heat sink be built into the PCB (if the ground plane layer is not exposed). This is done by including a copper area of about 2 square inches on the opposite side of the PCB from the device. This copper area may be plated or solder coated to prevent corrosion but should not have conformal coating (if possible), which could provide thermal insulation. The vias shown in [Figure 9-20](#) should connect these top and bottom copper layers and to the ground layer. These vias act as “heat pipes” to carry the thermal energy away from the device side of the board to where it can be more effectively dissipated.

---

## Revision History

NOTE: Page numbers for previous revisions may differ from page numbers in the current version.

---

| <b>Changes from Revision I (March 2013) to Revision J</b>  | <b>Page</b>         |
|--|---------------------|
| <ul style="list-style-type: none"><li>• Changed layout of National Data Sheet to TI format .....</li></ul> | <a href="#">124</a> |

---

**PACKAGING INFORMATION**

| Orderable Device   | Status<br>(1) | Package Type | Package<br>Drawing | Pins | Package<br>Qty | Eco Plan<br>(2)            | Lead/Ball Finish | MSL Peak Temp<br>(3) | Op Temp (°C) | Top-Side Markings<br>(4) | Samples                 |
|--------------------|---------------|--------------|--------------------|------|----------------|----------------------------|------------------|----------------------|--------------|--------------------------|-------------------------|
| LMK04803BISQ/NOPB  | ACTIVE        | WQFN         | NKD                | 64   | 1000           | Green (RoHS<br>& no Sb/Br) | SN               | Level-3-260C-168 HR  | -40 to 85    | K04803BISQ               | <a href="#">Samples</a> |
| LMK04803BISQE/NOPB | ACTIVE        | WQFN         | NKD                | 64   | 250            | Green (RoHS<br>& no Sb/Br) | SN               | Level-3-260C-168 HR  | -40 to 85    | K04803BISQ               | <a href="#">Samples</a> |
| LMK04803BISQX/NOPB | ACTIVE        | WQFN         | NKD                | 64   | 2000           | Green (RoHS<br>& no Sb/Br) | SN               | Level-3-260C-168 HR  | -40 to 85    | K04803BISQ               | <a href="#">Samples</a> |
| LMK04805BISQ/NOPB  | ACTIVE        | WQFN         | NKD                | 64   | 1000           | Green (RoHS<br>& no Sb/Br) | SN               | Level-3-260C-168 HR  | -40 to 85    | K04805BISQ               | <a href="#">Samples</a> |
| LMK04805BISQE/NOPB | ACTIVE        | WQFN         | NKD                | 64   | 250            | Green (RoHS<br>& no Sb/Br) | SN               | Level-3-260C-168 HR  | -40 to 85    | K04805BISQ               | <a href="#">Samples</a> |
| LMK04805BISQX/NOPB | ACTIVE        | WQFN         | NKD                | 64   | 2000           | Green (RoHS<br>& no Sb/Br) | SN               | Level-3-260C-168 HR  | -40 to 85    | K04805BISQ               | <a href="#">Samples</a> |
| LMK04806BISQ/NOPB  | ACTIVE        | WQFN         | NKD                | 64   | 1000           | Green (RoHS<br>& no Sb/Br) | SN               | Level-3-260C-168 HR  | -40 to 85    | K04806BISQ               | <a href="#">Samples</a> |
| LMK04806BISQE/NOPB | ACTIVE        | WQFN         | NKD                | 64   | 250            | Green (RoHS<br>& no Sb/Br) | SN               | Level-3-260C-168 HR  | -40 to 85    | K04806BISQ               | <a href="#">Samples</a> |
| LMK04806BISQX/NOPB | ACTIVE        | WQFN         | NKD                | 64   | 2000           | Green (RoHS<br>& no Sb/Br) | SN               | Level-3-260C-168 HR  | -40 to 85    | K04806BISQ               | <a href="#">Samples</a> |
| LMK04808BISQ/NOPB  | ACTIVE        | WQFN         | NKD                | 64   | 1000           | Green (RoHS<br>& no Sb/Br) | SN               | Level-3-260C-168 HR  | -40 to 85    | K04808BISQ               | <a href="#">Samples</a> |
| LMK04808BISQE/NOPB | ACTIVE        | WQFN         | NKD                | 64   | 250            | Green (RoHS<br>& no Sb/Br) | SN               | Level-3-260C-168 HR  | -40 to 85    | K04808BISQ               | <a href="#">Samples</a> |
| LMK04808BISQX/NOPB | ACTIVE        | WQFN         | NKD                | 64   | 2000           | Green (RoHS<br>& no Sb/Br) | SN               | Level-3-260C-168 HR  | -40 to 85    | K04808BISQ               | <a href="#">Samples</a> |

(1) The marketing status values are defined as follows:

**ACTIVE:** Product device recommended for new designs.

**LIFEBUY:** TI has announced that the device will be discontinued, and a lifetime-buy period is in effect.

**NRND:** Not recommended for new designs. Device is in production to support existing customers, but TI does not recommend using this part in a new design.

**PREVIEW:** Device has been announced but is not in production. Samples may or may not be available.

**OBSELETE:** TI has discontinued the production of the device.

(2) Eco Plan - The planned eco-friendly classification: Pb-Free (RoHS), Pb-Free (RoHS Exempt), or Green (RoHS & no Sb/Br) - please check <http://www.ti.com/productcontent> for the latest availability information and additional product content details.

**TBD:** The Pb-Free/Green conversion plan has not been defined.

---

**Pb-Free (RoHS):** TI's terms "Lead-Free" or "Pb-Free" mean semiconductor products that are compatible with the current RoHS requirements for all 6 substances, including the requirement that lead not exceed 0.1% by weight in homogeneous materials. Where designed to be soldered at high temperatures, TI Pb-Free products are suitable for use in specified lead-free processes.

**Pb-Free (RoHS Exempt):** This component has a RoHS exemption for either 1) lead-based flip-chip solder bumps used between the die and package, or 2) lead-based die adhesive used between the die and leadframe. The component is otherwise considered Pb-Free (RoHS compatible) as defined above.

**Green (RoHS & no Sb/Br):** TI defines "Green" to mean Pb-Free (RoHS compatible), and free of Bromine (Br) and Antimony (Sb) based flame retardants (Br or Sb do not exceed 0.1% by weight in homogeneous material)

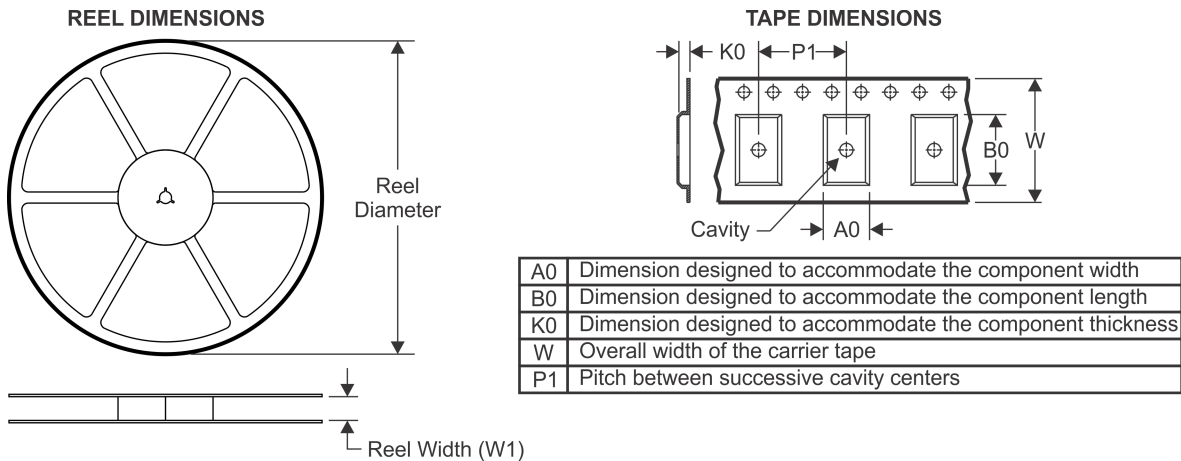
<sup>(3)</sup> MSL, Peak Temp. -- The Moisture Sensitivity Level rating according to the JEDEC industry standard classifications, and peak solder temperature.

<sup>(4)</sup> Multiple Top-Side Markings will be inside parentheses. Only one Top-Side Marking contained in parentheses and separated by a "~" will appear on a device. If a line is indented then it is a continuation of the previous line and the two combined represent the entire Top-Side Marking for that device.

**Important Information and Disclaimer:** The information provided on this page represents TI's knowledge and belief as of the date that it is provided. TI bases its knowledge and belief on information provided by third parties, and makes no representation or warranty as to the accuracy of such information. Efforts are underway to better integrate information from third parties. TI has taken and continues to take reasonable steps to provide representative and accurate information but may not have conducted destructive testing or chemical analysis on incoming materials and chemicals. TI and TI suppliers consider certain information to be proprietary, and thus CAS numbers and other limited information may not be available for release.

In no event shall TI's liability arising out of such information exceed the total purchase price of the TI part(s) at issue in this document sold by TI to Customer on an annual basis.

**TAPE AND REEL INFORMATION**



**QUADRANT ASSIGNMENTS FOR PIN 1 ORIENTATION IN TAPE**



\*All dimensions are nominal

| Device             | Package Type | Package Drawing | Pins | SPQ  | Reel Diameter (mm) | Reel Width W1 (mm) | A0 (mm) | B0 (mm) | K0 (mm) | P1 (mm) | W (mm) | Pin1 Quadrant |
|--------------------|--------------|-----------------|------|------|--------------------|--------------------|---------|---------|---------|---------|--------|---------------|
| LMK04803BISQ/NOPB  | WQFN         | NKD             | 64   | 1000 | 330.0              | 16.4               | 9.3     | 9.3     | 1.3     | 12.0    | 16.0   | Q1            |
| LMK04803BISQE/NOPB | WQFN         | NKD             | 64   | 250  | 178.0              | 16.4               | 9.3     | 9.3     | 1.3     | 12.0    | 16.0   | Q1            |
| LMK04803BISQX/NOPB | WQFN         | NKD             | 64   | 2000 | 330.0              | 16.4               | 9.3     | 9.3     | 1.3     | 12.0    | 16.0   | Q1            |
| LMK04805BISQ/NOPB  | WQFN         | NKD             | 64   | 1000 | 330.0              | 16.4               | 9.3     | 9.3     | 1.3     | 12.0    | 16.0   | Q1            |
| LMK04805BISQE/NOPB | WQFN         | NKD             | 64   | 250  | 178.0              | 16.4               | 9.3     | 9.3     | 1.3     | 12.0    | 16.0   | Q1            |
| LMK04805BISQX/NOPB | WQFN         | NKD             | 64   | 2000 | 330.0              | 16.4               | 9.3     | 9.3     | 1.3     | 12.0    | 16.0   | Q1            |
| LMK04806BISQ/NOPB  | WQFN         | NKD             | 64   | 1000 | 330.0              | 16.4               | 9.3     | 9.3     | 1.3     | 12.0    | 16.0   | Q1            |
| LMK04806BISQE/NOPB | WQFN         | NKD             | 64   | 250  | 178.0              | 16.4               | 9.3     | 9.3     | 1.3     | 12.0    | 16.0   | Q1            |
| LMK04806BISQX/NOPB | WQFN         | NKD             | 64   | 2000 | 330.0              | 16.4               | 9.3     | 9.3     | 1.3     | 12.0    | 16.0   | Q1            |
| LMK04808BISQ/NOPB  | WQFN         | NKD             | 64   | 1000 | 330.0              | 16.4               | 9.3     | 9.3     | 1.3     | 12.0    | 16.0   | Q1            |
| LMK04808BISQE/NOPB | WQFN         | NKD             | 64   | 250  | 178.0              | 16.4               | 9.3     | 9.3     | 1.3     | 12.0    | 16.0   | Q1            |
| LMK04808BISQX/NOPB | WQFN         | NKD             | 64   | 2000 | 330.0              | 16.4               | 9.3     | 9.3     | 1.3     | 12.0    | 16.0   | Q1            |

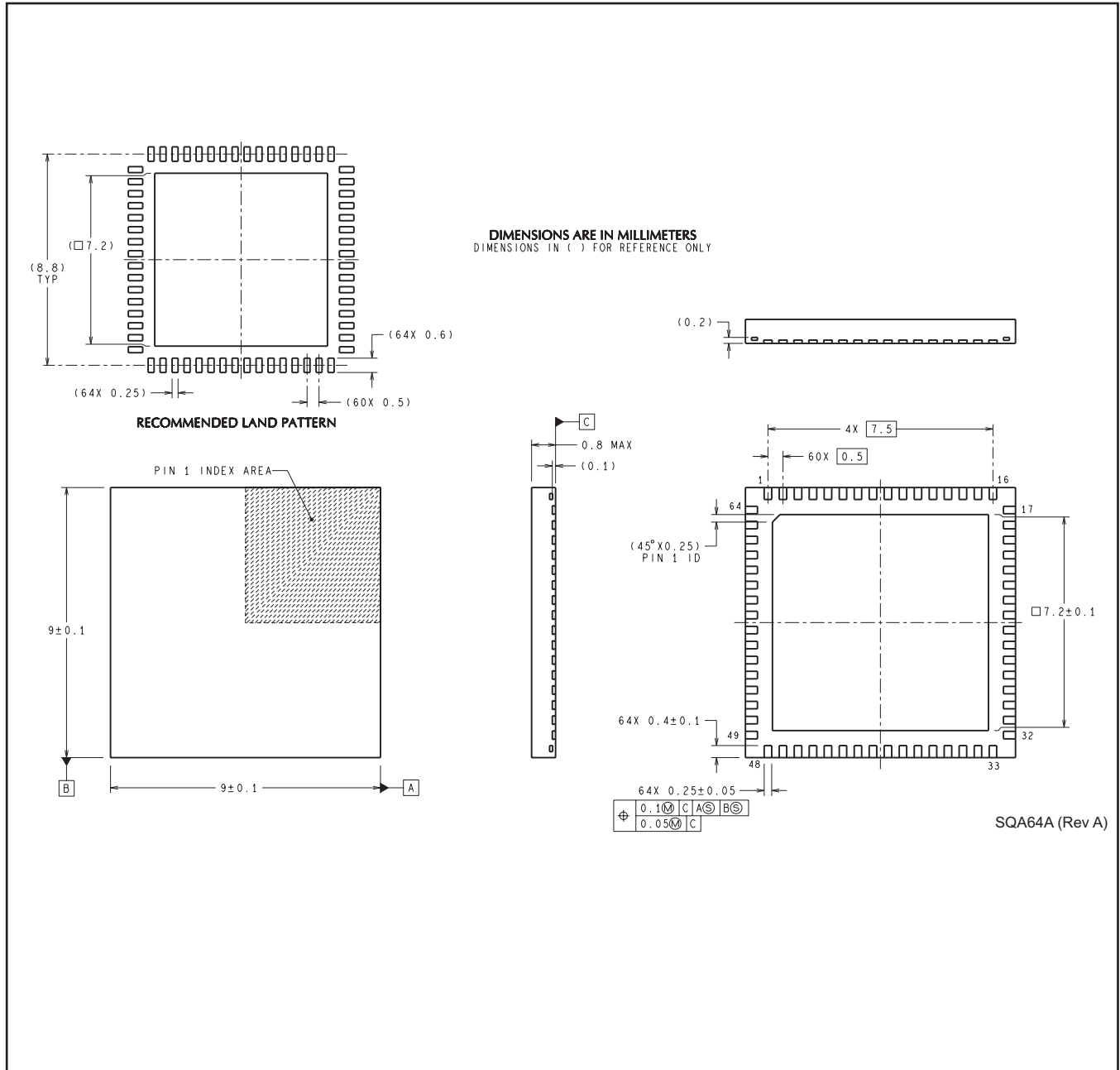


**TAPE AND REEL BOX DIMENSIONS**


\*All dimensions are nominal

| Device             | Package Type | Package Drawing | Pins | SPQ  | Length (mm) | Width (mm) | Height (mm) |
|--------------------|--------------|-----------------|------|------|-------------|------------|-------------|
| LMK04803BISQ/NOPB  | WQFN         | NKD             | 64   | 1000 | 367.0       | 367.0      | 38.0        |
| LMK04803BISQE/NOPB | WQFN         | NKD             | 64   | 250  | 213.0       | 191.0      | 55.0        |
| LMK04803BISQX/NOPB | WQFN         | NKD             | 64   | 2000 | 367.0       | 367.0      | 38.0        |
| LMK04805BISQ/NOPB  | WQFN         | NKD             | 64   | 1000 | 367.0       | 367.0      | 38.0        |
| LMK04805BISQE/NOPB | WQFN         | NKD             | 64   | 250  | 213.0       | 191.0      | 55.0        |
| LMK04805BISQX/NOPB | WQFN         | NKD             | 64   | 2000 | 367.0       | 367.0      | 38.0        |
| LMK04806BISQ/NOPB  | WQFN         | NKD             | 64   | 1000 | 367.0       | 367.0      | 38.0        |
| LMK04806BISQE/NOPB | WQFN         | NKD             | 64   | 250  | 213.0       | 191.0      | 55.0        |
| LMK04806BISQX/NOPB | WQFN         | NKD             | 64   | 2000 | 367.0       | 367.0      | 38.0        |
| LMK04808BISQ/NOPB  | WQFN         | NKD             | 64   | 1000 | 367.0       | 367.0      | 38.0        |
| LMK04808BISQE/NOPB | WQFN         | NKD             | 64   | 250  | 213.0       | 191.0      | 55.0        |
| LMK04808BISQX/NOPB | WQFN         | NKD             | 64   | 2000 | 367.0       | 367.0      | 38.0        |

NKD0064A



## IMPORTANT NOTICE

Texas Instruments Incorporated and its subsidiaries (TI) reserve the right to make corrections, enhancements, improvements and other changes to its semiconductor products and services per JESD46, latest issue, and to discontinue any product or service per JESD48, latest issue. Buyers should obtain the latest relevant information before placing orders and should verify that such information is current and complete. All semiconductor products (also referred to herein as "components") are sold subject to TI's terms and conditions of sale supplied at the time of order acknowledgment.

TI warrants performance of its components to the specifications applicable at the time of sale, in accordance with the warranty in TI's terms and conditions of sale of semiconductor products. Testing and other quality control techniques are used to the extent TI deems necessary to support this warranty. Except where mandated by applicable law, testing of all parameters of each component is not necessarily performed.

TI assumes no liability for applications assistance or the design of Buyers' products. Buyers are responsible for their products and applications using TI components. To minimize the risks associated with Buyers' products and applications, Buyers should provide adequate design and operating safeguards.

TI does not warrant or represent that any license, either express or implied, is granted under any patent right, copyright, mask work right, or other intellectual property right relating to any combination, machine, or process in which TI components or services are used. Information published by TI regarding third-party products or services does not constitute a license to use such products or services or a warranty or endorsement thereof. Use of such information may require a license from a third party under the patents or other intellectual property of the third party, or a license from TI under the patents or other intellectual property of TI.

Reproduction of significant portions of TI information in TI data books or data sheets is permissible only if reproduction is without alteration and is accompanied by all associated warranties, conditions, limitations, and notices. TI is not responsible or liable for such altered documentation. Information of third parties may be subject to additional restrictions.

Resale of TI components or services with statements different from or beyond the parameters stated by TI for that component or service voids all express and any implied warranties for the associated TI component or service and is an unfair and deceptive business practice. TI is not responsible or liable for any such statements.

Buyer acknowledges and agrees that it is solely responsible for compliance with all legal, regulatory and safety-related requirements concerning its products, and any use of TI components in its applications, notwithstanding any applications-related information or support that may be provided by TI. Buyer represents and agrees that it has all the necessary expertise to create and implement safeguards which anticipate dangerous consequences of failures, monitor failures and their consequences, lessen the likelihood of failures that might cause harm and take appropriate remedial actions. Buyer will fully indemnify TI and its representatives against any damages arising out of the use of any TI components in safety-critical applications.

In some cases, TI components may be promoted specifically to facilitate safety-related applications. With such components, TI's goal is to help enable customers to design and create their own end-product solutions that meet applicable functional safety standards and requirements. Nonetheless, such components are subject to these terms.

No TI components are authorized for use in FDA Class III (or similar life-critical medical equipment) unless authorized officers of the parties have executed a special agreement specifically governing such use.

Only those TI components which TI has specifically designated as military grade or "enhanced plastic" are designed and intended for use in military/aerospace applications or environments. Buyer acknowledges and agrees that any military or aerospace use of TI components which have **not** been so designated is solely at the Buyer's risk, and that Buyer is solely responsible for compliance with all legal and regulatory requirements in connection with such use.

TI has specifically designated certain components as meeting ISO/TS16949 requirements, mainly for automotive use. In any case of use of non-designated products, TI will not be responsible for any failure to meet ISO/TS16949.

### Products

|                              |  |
|------------------------------|--|
| Audio                        | <a href="http://www.ti.com/audio">www.ti.com/audio</a>                               |
| Amplifiers                   | <a href="http://amplifier.ti.com">amplifier.ti.com</a>                               |
| Data Converters              | <a href="http://dataconverter.ti.com">dataconverter.ti.com</a>                       |
| DLP® Products                | <a href="http://www.dlp.com">www.dlp.com</a>   |
| DSP                          | <a href="http://dsp.ti.com">dsp.ti.com</a>   |
| Clocks and Timers            | <a href="http://www.ti.com/clocks">www.ti.com/clocks</a>                             |
| Interface                    | <a href="http://interface.ti.com">interface.ti.com</a>                               |
| Logic                        | <a href="http://logic.ti.com">logic.ti.com</a>                                       |
| Power Mgmt                   | <a href="http://power.ti.com">power.ti.com</a>                                       |
| Microcontrollers             | <a href="http://microcontroller.ti.com">microcontroller.ti.com</a>                   |
| RFID                         | <a href="http://www.ti-rfid.com">www.ti-rfid.com</a>                                 |
| OMAP Applications Processors | <a href="http://www.ti.com/omap">www.ti.com/omap</a>                                 |
| Wireless Connectivity        | <a href="http://www.ti.com/wirelessconnectivity">www.ti.com/wirelessconnectivity</a> |

### Applications

|                               |  |
|-------------------------------|--|
| Automotive and Transportation | <a href="http://www.ti.com/automotive">www.ti.com/automotive</a>                         |
| Communications and Telecom    | <a href="http://www.ti.com/communications">www.ti.com/communications</a>                 |
| Computers and Peripherals     | <a href="http://www.ti.com/computers">www.ti.com/computers</a>                           |
| Consumer Electronics          | <a href="http://www.ti.com/consumer-apps">www.ti.com/consumer-apps</a>                   |
| Energy and Lighting           | <a href="http://www.ti.com/energy">www.ti.com/energy</a>                                 |
| Industrial                    | <a href="http://www.ti.com/industrial">www.ti.com/industrial</a>                         |
| Medical                       | <a href="http://www.ti.com/medical">www.ti.com/medical</a>                               |
| Security                      | <a href="http://www.ti.com/security">www.ti.com/security</a>                             |
| Space, Avionics and Defense   | <a href="http://www.ti.com/space-avionics-defense">www.ti.com/space-avionics-defense</a> |
| Video and Imaging             | <a href="http://www.ti.com/video">www.ti.com/video</a>                                   |

### TI E2E Community

[e2e.ti.com](http://e2e.ti.com)