

## LM1894 Dynamic Noise Reduction System DNR

Check for Samples: [LM1894](#)

### FEATURES

- **Non-Complementary Noise Reduction, “Single Ended”**
- **Low Cost External Components, No Critical Matching**
- **Compatible with All Prerecorded Tapes and FM**
- **10 dB Effective Tape Noise Reduction CCIR/ARM Weighted**
- **Wide Supply Range, 4.5V to 18V**
- **1 Vrms Input Overload**

### APPLICATIONS

- **Automotive Radio/Tape Players**
- **Compact Portable Tape Players**
- **Quality HI-FI Tape Systems**
- **VCR Playback Noise Reduction**
- **Video Disc Playback Noise Reduction**

### DESCRIPTION

The LM1894 is a stereo noise reduction circuit for use with audio playback systems. The DNR system is non-complementary, meaning it does not require encoded source material. The system is compatible with virtually all pre-recorded tapes and FM broadcasts. Psychoacoustic masking, and an adaptive bandwidth scheme allow the DNR to achieve 10 dB of noise reduction. DNR can save circuit board space and cost because of the few additional components required.



Please be aware that an important notice concerning availability, standard warranty, and use in critical applications of Texas Instruments semiconductor products and disclaimers thereto appears at the end of this data sheet.

All trademarks are the property of their respective owners.

## Typical Application

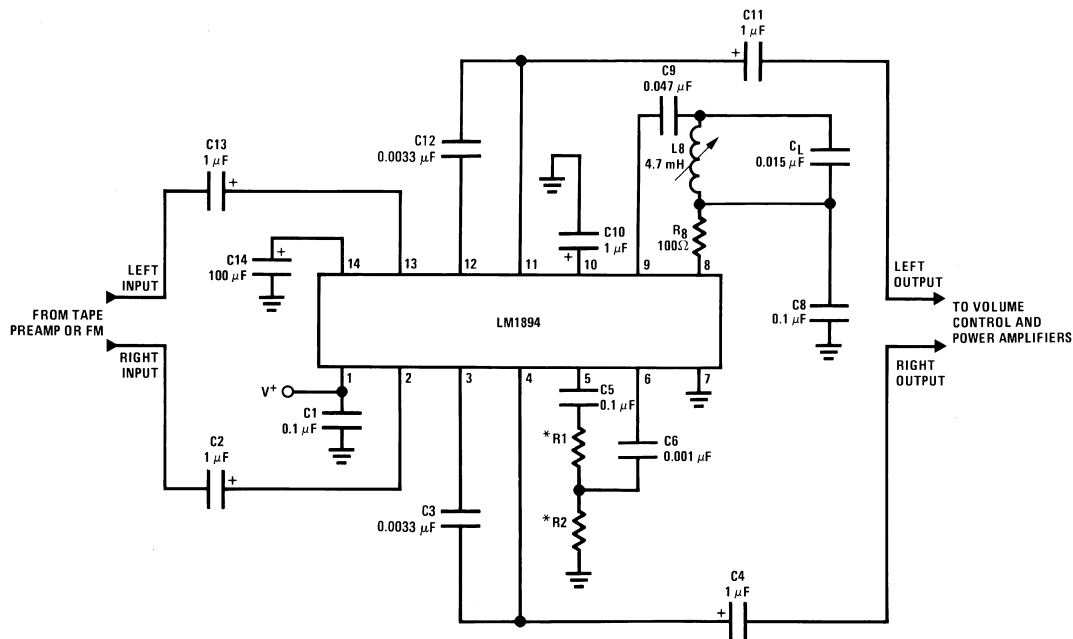

\*R1 + R2 = 1 kΩ total.  
See [Application Hints](#).

**Figure 1. Component Hook-Up for Stereo DNR System**  
**14-Pin SOIC or PDIP or TSSOP**  
 See D or NFF0014A or PW Package



These devices have limited built-in ESD protection. The leads should be shorted together or the device placed in conductive foam during storage or handling to prevent electrostatic damage to the MOS gates.

### Absolute Maximum Ratings<sup>(1)(2)</sup>

|                                      |              |                          |                 |
|--------------------------------------|--------------|--------------------------|-----------------|
| Supply Voltage                       |              |                          | 20V             |
| Input Voltage Range, $V_{pk}$        |              |                          | $V_S/2$         |
| Operating Temperature <sup>(3)</sup> |              |                          | 0°C to +70°C    |
| Storage Temperature                  |              |                          | -65°C to +150°C |
| Soldering Information                | PDIP Package | Soldering (10 seconds)   | 260°C           |
|                                      | SOIC Package | Vapor Phase (60 seconds) | 215°C           |
|                                      |              | Infrared (15 seconds)    | 220°C           |

- (1) "Absolute Maximum Ratings" indicate limits beyond which damage to the device may occur. Operating Ratings indicate conditions for which the device is functional, but do not ensure specific performance limits.
- (2) If Military/Aerospace specified devices are required, please contact the Texas Instruments Sales Office/Distributors for availability and specifications.
- (3) For operation in ambient temperature above 25°C, the device must be derated based on a 150°C maximum junction temperature and a thermal resistance of:
  - (a) 80°C/W junction to ambient for the PDIP package,
  - (b) 105°C/W junction to ambient for the SOIC package, and
  - (c) 150°C/W junction to ambient for the TSSOP package.

## Electrical Characteristics

$V_S = 8V$ ,  $T_A = 25^\circ C$ ,  $V_{IN} = 300\text{ mV}$  at 1 kHz, circuit shown in [Figure 1](#) unless otherwise specified

| Parameter                 | Conditions   | Min  | Typ         | Max  | Units            |
|---------------------------|--|------|-------------|------|------------------|
| Operating Supply Range    |  | 4.5  | 8           | 18   | V                |
| Supply Current            | $V_S = 8V$   |      | 17          | 30   | mA               |
| <b>MAIN SIGNAL PATH</b>   |  |      |             |      |                  |
| Voltage Gain              | DC Ground Pin 9 <sup>(1)</sup>   | -0.9 | -1          | -1.1 | V/V              |
| DC Output Voltage         |  | 3.7  | 4.0         | 4.3  | V                |
| Channel Balance           | DC Ground Pin 9  | -1.0 |             | 1.0  | dB               |
| Minimum Balance           | AC Ground Pin 9 with 0.1 $\mu F$ Capacitor <sup>(1)</sup>  | 675  | 965         | 1400 | Hz               |
| Maximum Bandwidth         | DC Ground Pin 9 <sup>(1)</sup>   | 27   | 34          | 46   | kHz              |
| Effective Noise Reduction | CCIR/ARM Weighted <sup>(2)</sup>   |      | -10         | -14  | dB               |
| Total Harmonic Distortion | DC Ground Pin 9  |      | 0.05        | 0.1  | %                |
| Input Headroom            | Maximum $V_{IN}$ for 3% THD<br>AC Ground Pin 9   |      | 1.0         |      | V <sub>rms</sub> |
| Output Headroom           | Maximum $V_{OUT}$ for 3% THD<br>DC Ground Pin 9  |      | $V_S - 1.5$ |      | V <sub>p-p</sub> |
| Signal to Noise           | BW = 20 Hz–20 kHz, re 300 mV<br>AC Ground Pin 9  |      | 79          |      | dB               |
|                           | DC Ground Pin 9  |      | 77          |      | dB               |
|                           | CCIR/ARM Weighted re 300 mV <sup>(3)</sup><br>AC Ground Pin 9  | 82   | 88          |      | dB               |
|                           | DC Ground Pin 9  | 70   | 76          |      | dB               |
|                           | CCIR Peak, re 300 mV <sup>(4)</sup><br>AC Ground Pin 9   |      | 77          |      | dB               |
|                           | DC Ground Pin 9  |      | 64          |      | dB               |
| Input Impedance           | Pin 2 and Pin 13   | 14   | 20          | 26   | k $\Omega$       |
| Channel Separation        | DC Ground Pin 9  | -50  | -70         |      | dB               |
| Power Supply Rejection    | C14 = 100 $\mu F$ ,<br>$V_{RIPPLE} = 500\text{ mV}_{rms}$ ,<br>$f = 1\text{ kHz}$                            | -40  | -56         |      | dB               |
| Output DC Shift           | Reference DVM to Pin 14 and<br>Measuree Output DC Shift from<br>Minimum to Maximum Band-width <sup>(5)</sup> |      | 4.0         | 20   | mV               |

- (1) To force the DNR system into maximum bandwidth, DC ground the input to the peak detector, pin 9. A negative temperature coefficient of  $-0.5\%/^\circ C$  on the bandwidth, reduces the maximum bandwidth at increased ambient temperature or higher package dissipation. AC ground pin 9 or pin 6 to select minimum bandwidth. To change minimum and maximum bandwidth, see [Application Hints](#).
- (2) The maximum noise reduction CCIR/ARM weighted is about 14 dB. This is accomplished by changing the bandwidth from maximum to minimum. In actual operation, minimum bandwidth is not selected, a nominal minimum bandwidth of about 2 kHz gives  $-10\text{ dB}$  of noise reduction. See [Application Hints](#).
- (3) The CCIR/ARM weighted noise is measured with a 40 dB gain amplifier between the DNR system and the CCIR weighting filter; it is then input referred.
- (4) Measured using the Rhode-Schwartz psophometer.
- (5) Pin 10 is DC forced half way between the maximum bandwidth DC level and minimum bandwidth DC level. An AC 1 kHz signal is then applied to pin 10. Its peak-to-peak amplitude is  $V_{DC}(\text{max BW}) - V_{DC}(\text{min BW})$ .

## Electrical Characteristics (continued)

$V_S = 8V$ ,  $T_A = 25^\circ C$ ,  $V_{IN} = 300\text{ mV}$  at 1 kHz, circuit shown in [Figure 1](#) unless otherwise specified

| Parameter                      | Conditions  | Min  | Typ | Max  | Units      |
|--------------------------------|---|------|-----|------|------------|
| <b>CONTROL SIGNAL PATH</b>     |   |      |     |      |            |
| Summing Amplifier Voltage Gain | Both Channels Driven                                  | 0.9  | 1   | 1.1  | V/V        |
| Gain Amplifier Input Impedance | Pin 6   | 24   | 30  | 39   | k $\Omega$ |
| Voltage Gain                   | Pin 6 to Pin 8  | 21.5 | 24  | 26.5 | V/V        |
| Peak Detector Input Impedance  | Pin 9   | 560  | 700 | 840  | $\Omega$   |
| Voltage Gain                   | Pin 9 to Pin 10                                       | 30   | 33  | 36   | V/V        |
| Attack Time                    | Measured to 90% of Final Value with 10 kHz Tone Burst | 300  | 500 | 700  | $\mu s$    |
| Decay Time                     | Measured to 90% of Final Value with 10 kHz Tone Burst | 45   | 60  | 75   | ms         |
| DC Voltage Range               | Minimum Bandwidth to Maximum Bandwidth                | 1.1  |     | 3.8  | V          |

Typical Performance Characteristics

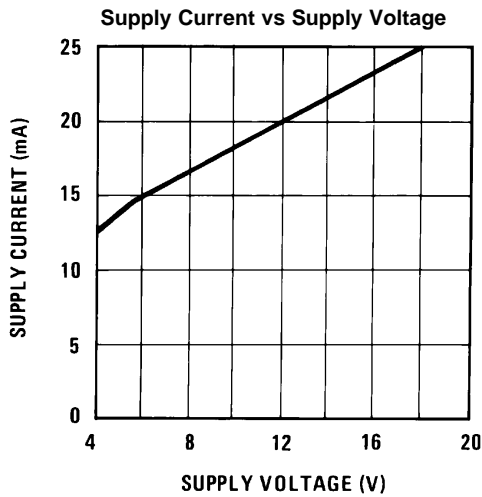

Figure 2.

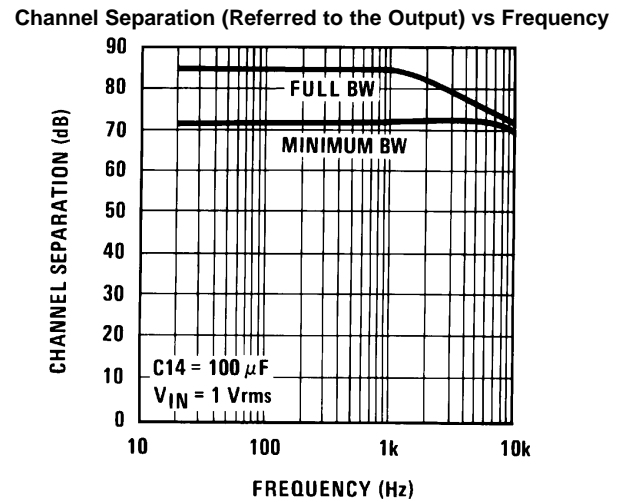

Figure 3.

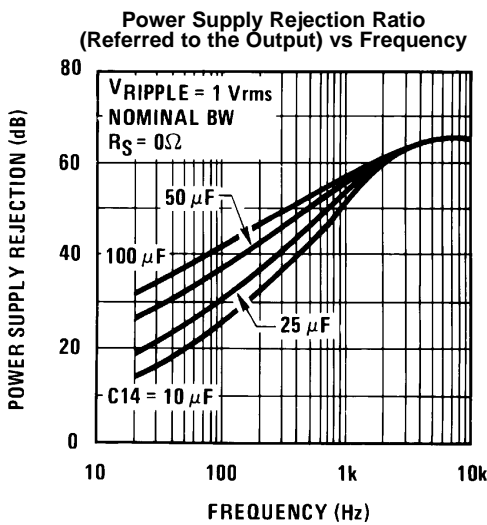

Figure 4.

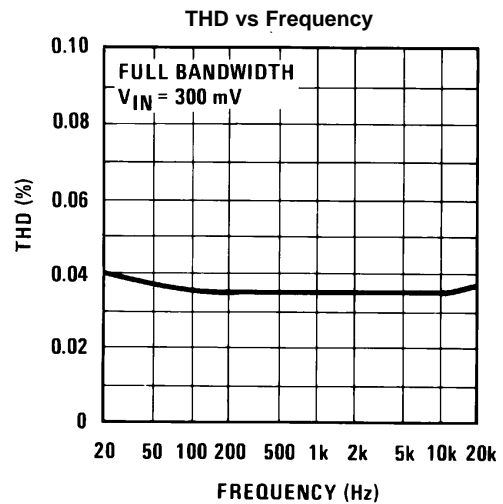

Figure 5.

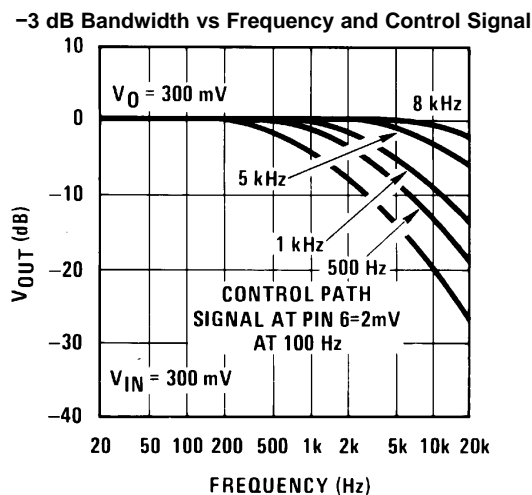

Figure 6.

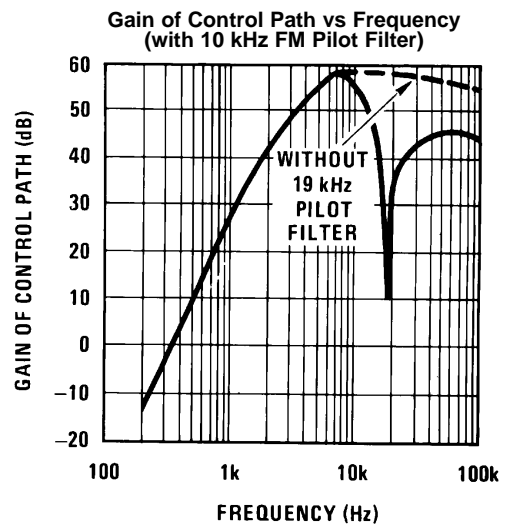
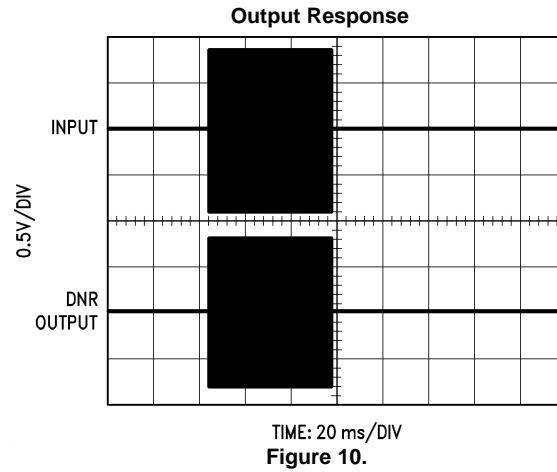
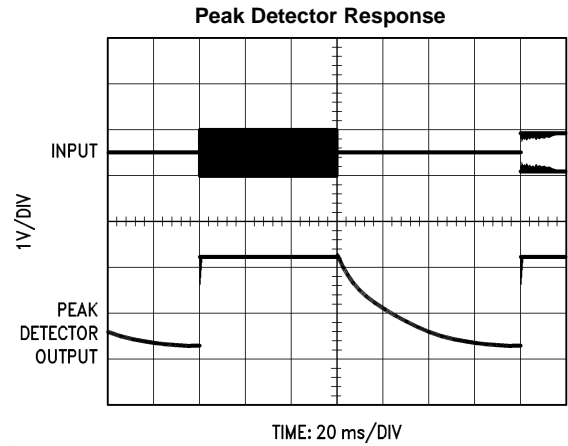
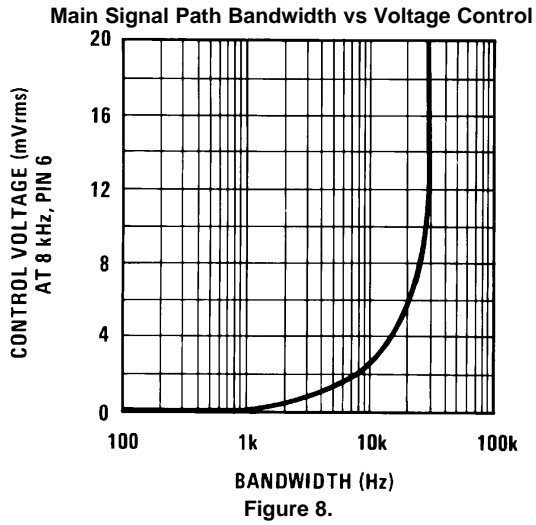

Figure 7.

**Typical Performance Characteristics (continued)**



## External Component Guide

(Figure 1)

| Component | Value                   | Purpose  |
|-----------|-------------------------|--|
| C1        | 0.1 $\mu$ F–100 $\mu$ F | May be part of power supply, or may be added to suppress power supply oscillation.   |
| C2, C13   | 1 $\mu$ F               | Blocks DC, pin 2 and pin 13 are at DC potential of $V_S/2$ . C2, C13 form a low frequency pole with 20k $R_{IN}$ .<br>$f_L = \frac{1}{2\pi C2 R_{IN}}$   |
| C14       | 25 $\mu$ F–100 $\mu$ F  | Improves power supply rejection.   |
| C3, C12   | 0.0033 $\mu$ F          | Forms integrator with internal gm block and op amp. Sets bandwidth conversion gain of 33 Hz/ $\mu$ A of gm current.  |
| C4, C11   | 1 $\mu$ F               | Output coupling capacitor. Output is at DC potential of $V_S/2$ .  |
| C5        | 0.1 $\mu$ F             | Works with R1 and R2 to attenuate low frequency transients which could disturb control path operation.<br>$f_5 = \frac{1}{2\pi C5 (R1 + R2)} = 1.6 \text{ kHz}$  |
| C6        | 0.001 $\mu$ F           | Works with input resistance of pin 6 to form part of control path frequency weighting.<br>$f_6 = \frac{1}{2\pi C6 R1_{PIN 6}} = 5.3 \text{ kHz}$   |
| C8        | 0.1 $\mu$ F             | Combined with L8 and $C_L$ forms 19 kHz filter for FM pilot. This is only required in FM applications <sup>(1)</sup> .   |
| L8, $C_L$ | 4.7 mH, 0.015 $\mu$ F   | Forms 19 kHz filter for FM pilot. L8 is Toko coil CAN-1A185HM <sup>(1)(2)</sup> .  |
| C9        | 0.047 $\mu$ F           | Works with input resistance of pin 9 to form part of control path frequency weighting.<br>$f_9 = \frac{1}{2\pi C9 R_{PIN 9}} = 4.8 \text{ kHz}$  |
| C10       | 1 $\mu$ F               | Set attack and decay time of peak detector.  |
| R1, R2    | 1 k $\Omega$            | Sensitivity resistors set the noise threshold. Reducing attenuation causes larger signals to be peak detected and larger bandwidth in main signal path. Total value of R1 + R2 should equal 1 k $\Omega$ . |
| R8        | 100 $\Omega$            | Forms RC roll-off with C8. This is only required in FM applications.   |

(1) When FM applications are not required, pin 8 and pin 9 hook-up as follows:

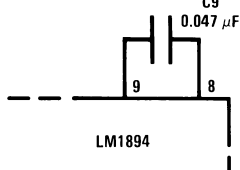

(2) Toko America Inc., 1250 Feehanville Drive, Mt. Prospect IL 60056

## Circuit Operation

The LM1894 has two signal paths, a main signal path and a bandwidth control path. The main path is an audio low pass filter comprised of a gm block with a variable current, and an op amp configured as an integrator. As seen in [Figure 11](#), DC feedback constrains the low frequency gain to  $A_V = -1$ . Above the cutoff frequency of the filter, the output decreases at  $-6$  dB/oct due to the action of the 0.0033  $\mu$ F capacitor.

The purpose of the control paths is to generate a bandwidth control signal which replicates the ear's sensitivity to noise in the presence of a tone. A single control path is used for both channels to keep the stereo image from wandering. This is done by adding the right and left channels together in the summing amplifier of [Figure 11](#). The R1, R2 resistor divider adjusts the incoming noise level to open slightly the bandwidth of the low pass filter. Control path gain is about 60 dB and is set by the gain amplifier and peak detector gain. This large gain is needed to ensure the low pass filter bandwidth can be opened by very low noise floors. The capacitors between

the summing amplifier output and the peak detector input determine the frequency weighting as shown in the [Typical Performance Characteristics](#). The 1  $\mu\text{F}$  capacitor at pin 10, in conjunction with internal resistors, sets the attack and decay times. The voltage is converted into a proportional current which is fed into the gm blocks. The bandwidth sensitivity to gm current is 33 Hz/ $\mu\text{A}$ . In FM stereo applications at 19 kHz pilot filter is inserted between pin 8 and pin 9 as shown in [Figure 1](#).

[Figure 12](#) is an interesting curve and deserves some discussion. Although the output of the DNR system is a linear function of input signal, the  $-3$  dB bandwidth is not. This is due to the non-linear nature of the control path. The DNR system has a uniform frequency response, but looking at the  $-3$  dB bandwidth on a steady state basis with a single frequency input can be misleading. It must be remembered that a single input frequency can only give a single  $-3$  dB bandwidth and the roll-off from this point must be a smooth  $-6$  dB/oct.

A more accurate evaluation of the frequency response can be seen in [Figure 13](#). In this case the main signal path is frequency swept, while the control path has a constant frequency applied. It can be seen that different control path frequencies each give a distinctive gain roll-off.

## PSYCHOACOUSTIC BASICS

The dynamic noise reduction system is a low pass filter that has a variable bandwidth of 1 kHz to 30 kHz, dependent on music spectrum. The DNR system operates on three principles of psychoacoustics.

1. White noise can mask pure tones. The total noise energy required to mask a pure tone must equal the energy of the tone itself. Within certain limits, the wider the band of masking noise about the tone, the lower the noise amplitude need be. As long as the total energy of the noise is equal to or greater than the energy of the tone, the tone will be inaudible. This principle may be turned around; when music is present, it is capable of masking noise in the same bandwidth.
2. The ear cannot detect distortion for less than 1 ms. On a transient basis, if distortion occurs in less than 1 ms, the ear acts as an integrator and is unable to detect it. Because of this, signals of sufficient energy to mask noise open bandwidth to 90% of the maximum value in less than 1 ms. Reducing the bandwidth to within 10% of its minimum value is done in about 60 ms: long enough to allow the ambience of the music to pass through, but not so long as to allow the noise floor to become audible.
3. Reducing the audio bandwidth reduces the audibility of noise. Audibility of noise is dependent on noise spectrum, or how the noise energy is distributed with frequency. Depending on the tape and the recorder equalization, tape noise spectrum may be slightly rolled off with frequency on a per octave basis. The ear sensitivity on the other hand greatly increases between 2 kHz and 10 kHz. Noise in this region is extremely audible. The DNR system low pass filters this noise. Low frequency music will not appreciably open the DNR bandwidth, thus 2 kHz to 20 kHz noise is not heard.



Block Diagram

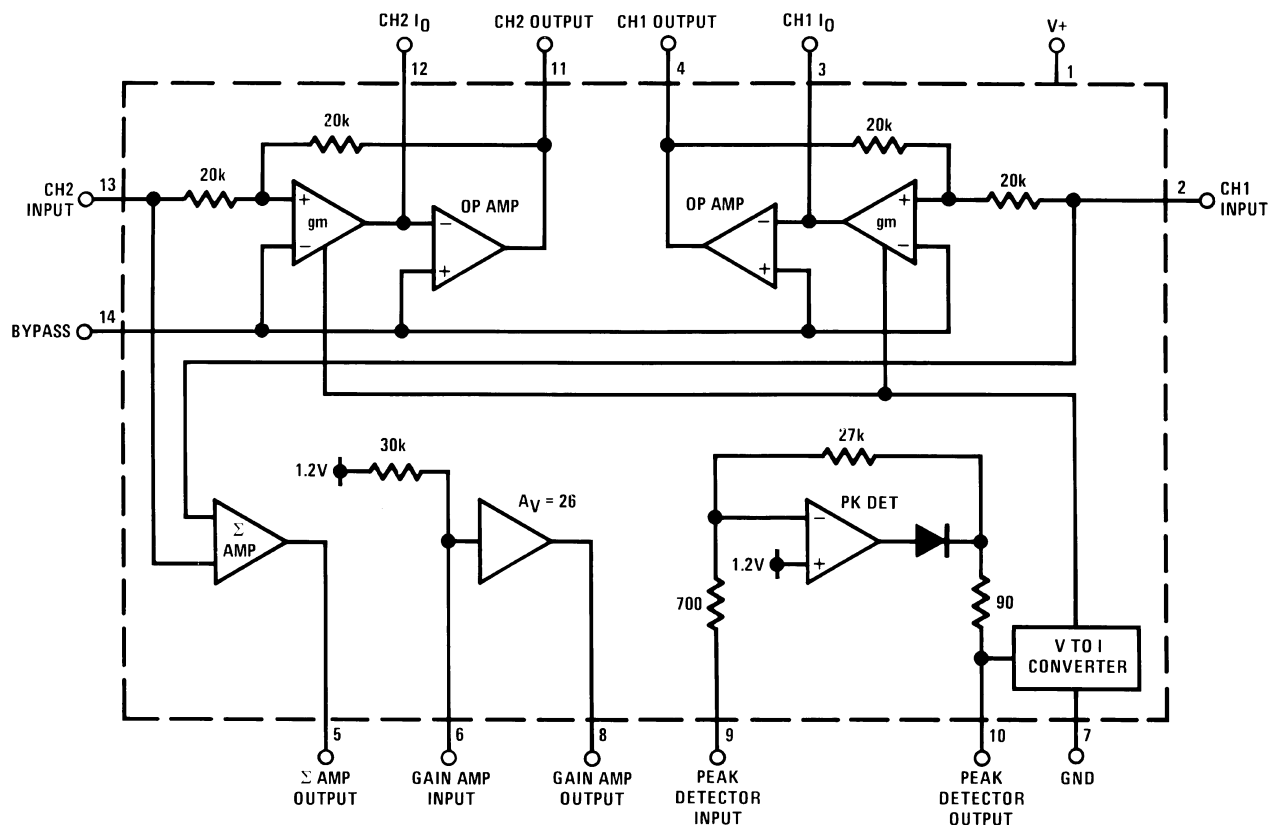

Figure 11.

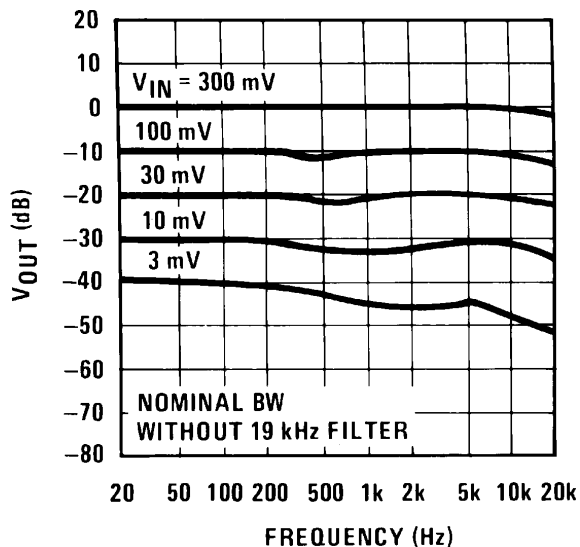

Figure 12. Output vs Frequency

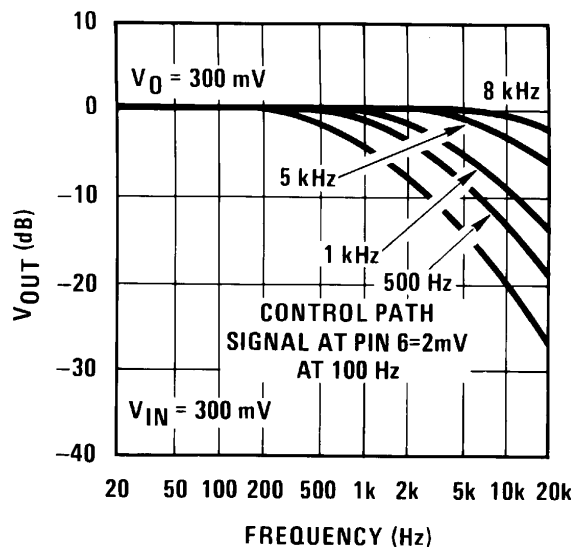

Figure 13. -3 dB Bandwidth vs Frequency and Control Signal

## APPLICATION HINTS

The DNR system should always be placed before tone and volume controls as shown in [Figure 1](#). This is because any adjustment of these controls would alter the noise floor seen by the DNR control path. The sensitivity resistors R1 and R2 may need to be switched with the input selector, depending on the noise floors of different sources, i.e., tape, FM, phono. To determine the value of R1 and R2 in a tape system for instance; apply tape noise (no program material) and adjust the ratio of R1 and R2 to open slightly the bandwidth of the main signal path. This can easily be done by viewing the capacitor voltage of pin 10 with an oscilloscope, or by using the circuit of [Figure 14](#). This circuit gives an LED display of the voltage on the peak detector capacitor. Adjust the values of R1 and R2 (their sum is always 1 k $\Omega$ ) to light the LEDs of pin 1 and pin 18. The LED bar graph does not indicate signal level, but rather instantaneous bandwidth of the two filters; it should not be used as a signal-level indicator. For greater flexibility in setting the bandwidth sensitivity, R1 and R2 could be replaced by a 1 k $\Omega$  potentiometer.

To change the minimum and maximum value of bandwidth, the integrating capacitors, C3 and C12, can be scaled up or down. Since the bandwidth is inversely proportional to the capacitance, changing this 0.0039  $\mu$ F capacitor to 0.0033  $\mu$ F will change the typical bandwidth from 965 Hz–34 kHz to 1.1 kHz–40 kHz. With C3 and C12 set at 0.0033  $\mu$ F, the maximum bandwidth is typically 34 kHz. A double pole double throw switch can be used to completely bypass DNR.

The capacitor on pin 10 in conjunction with internal resistors sets the attack and decay times. The attack time can be altered by changing the size of C10. Decay times can be decreased by paralleling a resistor with C10, and increased by increasing the value of C10.

When measuring the amount of noise reduction of the DNR system, the frequency response of the cassette should be flat to 10 kHz. The CCIR weighting network has substantial gain to 8 kHz and any additional roll-off in the cassette player will reduce the benefits of DNR noise reduction. A typical signal-to-noise measurement circuit is shown in [Figure 15](#). The DNR system should be switched from maximum bandwidth to nominal bandwidth with tape noise as a signal source. The reduction in measured noise is the signal-to-noise ratio improvement.

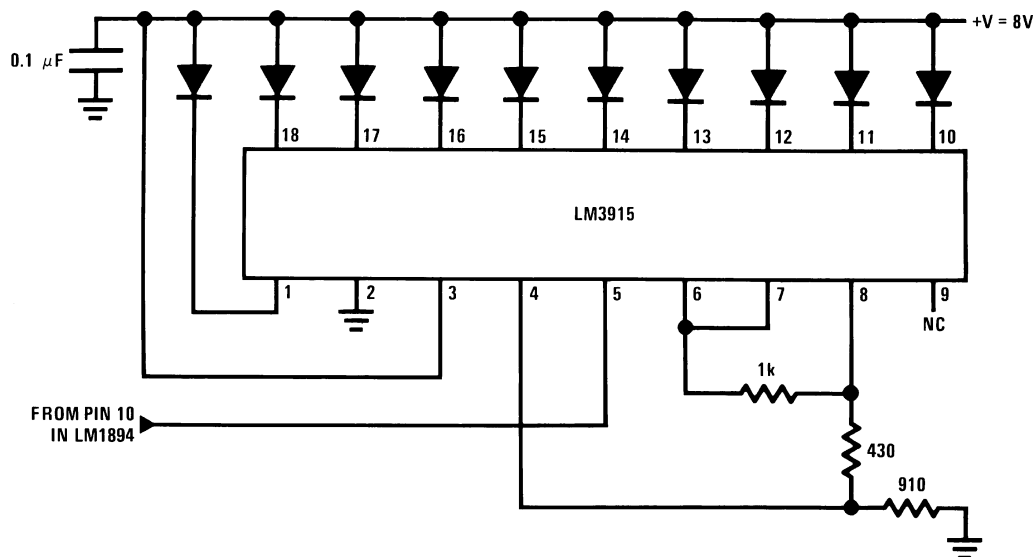

**Figure 14. Bar Graph Display of Peak Detector Voltage**

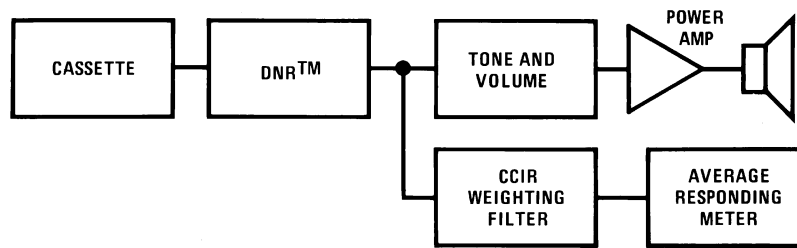

Figure 15. Technique for Measuring S/N Improvement of the DNR System

## FOR FURTHER READING

### Tape Noise Levels

1. "A Wide Range Dynamic Noise Reduction System", Blackmer, *"dB" Magazine*, August-September 1972, Volume 6, #8.
2. "Dolby B-Type Noise Reduction System", Berkowitz and Gundry, *Sert Journal*, May-June 1974, Volume 8.
3. "Cassette vs Elcaset vs Open Reel", Toole, *Audioscene Canada*, April 1978.
4. "CCIR/ARM: A Practical Noise Measurement Method", Dolby, Robinson, Gundry, *JAES*, 1978.

### Noise Masking

1. "Masking and Discrimination", Bos and De Boer, *JAES*, Volume 39, #4, 1966.
2. "The Masking of Pure Tones and Speech by White Noise", Hawkins and Stevens, *JAES*, Volume 22, #1, 1950.
3. "Sound System Engineering", Davis Howard W. Sams and Co.
4. "High Quality Sound Reproduction", Moir, Chapman Hall, 1960.
5. "Speech and Hearing in Communication", Fletcher, Van Nostrand, 1953.

Printed Circuit Layout

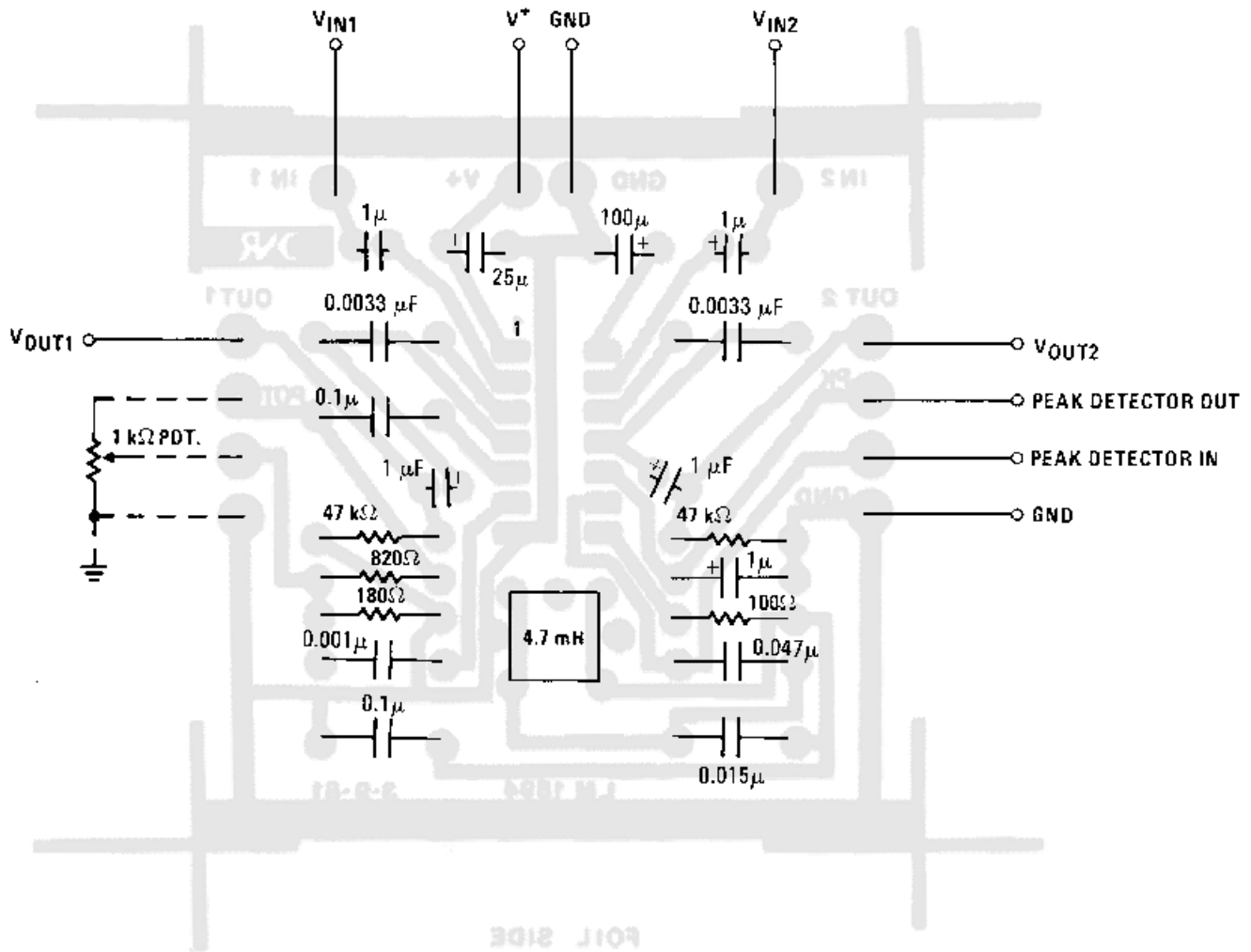

Figure 16. DNR Component Diagram

---

**REVISION HISTORY**

| <b>Changes from Revision B (April 2013) to Revision C</b>  | <b>Page</b>        |
|--|--------------------|
| • Changed layout of National Data Sheet to TI format ..... | <a href="#">11</a> |

---

**PACKAGING INFORMATION**

| Orderable Device | Status<br>(1) | Package Type | Package<br>Drawing | Pins | Package<br>Qty | Eco Plan<br>(2)            | Lead/Ball Finish | MSL Peak Temp<br>(3) | Op Temp (°C) | Top-Side Markings<br>(4) | Samples |
|------------------|---------------|--------------|--------------------|------|----------------|----------------------------|------------------|----------------------|--------------|--------------------------|---------|
| LM1894MX/NOPB    | NRND          | SOIC         | D                  | 14   | 2500           | Green (RoHS<br>& no Sb/Br) | CU SN            | Level-1-260C-UNLIM   | 0 to 70      | LM1894M                  |         |

(1) The marketing status values are defined as follows:

**ACTIVE:** Product device recommended for new designs.

**LIFEBUY:** TI has announced that the device will be discontinued, and a lifetime-buy period is in effect.

**NRND:** Not recommended for new designs. Device is in production to support existing customers, but TI does not recommend using this part in a new design.

**PREVIEW:** Device has been announced but is not in production. Samples may or may not be available.

**OBSOLETE:** TI has discontinued the production of the device.

(2) Eco Plan - The planned eco-friendly classification: Pb-Free (RoHS), Pb-Free (RoHS Exempt), or Green (RoHS & no Sb/Br) - please check <http://www.ti.com/productcontent> for the latest availability information and additional product content details.

**TBD:** The Pb-Free/Green conversion plan has not been defined.

**Pb-Free (RoHS):** TI's terms "Lead-Free" or "Pb-Free" mean semiconductor products that are compatible with the current RoHS requirements for all 6 substances, including the requirement that lead not exceed 0.1% by weight in homogeneous materials. Where designed to be soldered at high temperatures, TI Pb-Free products are suitable for use in specified lead-free processes.

**Pb-Free (RoHS Exempt):** This component has a RoHS exemption for either 1) lead-based flip-chip solder bumps used between the die and package, or 2) lead-based die adhesive used between the die and leadframe. The component is otherwise considered Pb-Free (RoHS compatible) as defined above.

**Green (RoHS & no Sb/Br):** TI defines "Green" to mean Pb-Free (RoHS compatible), and free of Bromine (Br) and Antimony (Sb) based flame retardants (Br or Sb do not exceed 0.1% by weight in homogeneous material)

(3) MSL, Peak Temp. -- The Moisture Sensitivity Level rating according to the JEDEC industry standard classifications, and peak solder temperature.

(4) Multiple Top-Side Markings will be inside parentheses. Only one Top-Side Marking contained in parentheses and separated by a "~" will appear on a device. If a line is indented then it is a continuation of the previous line and the two combined represent the entire Top-Side Marking for that device.

**Important Information and Disclaimer:**The information provided on this page represents TI's knowledge and belief as of the date that it is provided. TI bases its knowledge and belief on information provided by third parties, and makes no representation or warranty as to the accuracy of such information. Efforts are underway to better integrate information from third parties. TI has taken and continues to take reasonable steps to provide representative and accurate information but may not have conducted destructive testing or chemical analysis on incoming materials and chemicals. TI and TI suppliers consider certain information to be proprietary, and thus CAS numbers and other limited information may not be available for release.

In no event shall TI's liability arising out of such information exceed the total purchase price of the TI part(s) at issue in this document sold by TI to Customer on an annual basis.

## TAPE AND REEL INFORMATION



### QUADRANT ASSIGNMENTS FOR PIN 1 ORIENTATION IN TAPE



\*All dimensions are nominal

| Device        | Package Type | Package Drawing | Pins | SPQ  | Reel Diameter (mm) | Reel Width W1 (mm) | A0 (mm) | B0 (mm) | K0 (mm) | P1 (mm) | W (mm) | Pin1 Quadrant |
|---------------|--------------|-----------------|------|------|--------------------|--------------------|---------|---------|---------|---------|--------|---------------|
| LM1894MX/NOPB | SOIC         | D               | 14   | 2500 | 330.0              | 16.4               | 6.5     | 9.35    | 2.3     | 8.0     | 16.0   | Q1            |

**TAPE AND REEL BOX DIMENSIONS**



\*All dimensions are nominal

| Device        | Package Type | Package Drawing | Pins | SPQ  | Length (mm) | Width (mm) | Height (mm) |
|---------------|--------------|-----------------|------|------|-------------|------------|-------------|
| LM1894MX/NOPB | SOIC         | D               | 14   | 2500 | 367.0       | 367.0      | 35.0        |



D (R-PDSO-G14)

PLASTIC SMALL OUTLINE



- NOTES:
- A. All linear dimensions are in inches (millimeters).
  - B. This drawing is subject to change without notice.
  -  Body length does not include mold flash, protrusions, or gate burrs. Mold flash, protrusions, or gate burrs shall not exceed 0.006 (0,15) each side.
  -  Body width does not include interlead flash. Interlead flash shall not exceed 0.017 (0,43) each side.
  - E. Reference JEDEC MS-012 variation AB.

## IMPORTANT NOTICE

Texas Instruments Incorporated and its subsidiaries (TI) reserve the right to make corrections, enhancements, improvements and other changes to its semiconductor products and services per JESD46, latest issue, and to discontinue any product or service per JESD48, latest issue. Buyers should obtain the latest relevant information before placing orders and should verify that such information is current and complete. All semiconductor products (also referred to herein as "components") are sold subject to TI's terms and conditions of sale supplied at the time of order acknowledgment.

TI warrants performance of its components to the specifications applicable at the time of sale, in accordance with the warranty in TI's terms and conditions of sale of semiconductor products. Testing and other quality control techniques are used to the extent TI deems necessary to support this warranty. Except where mandated by applicable law, testing of all parameters of each component is not necessarily performed.

TI assumes no liability for applications assistance or the design of Buyers' products. Buyers are responsible for their products and applications using TI components. To minimize the risks associated with Buyers' products and applications, Buyers should provide adequate design and operating safeguards.

TI does not warrant or represent that any license, either express or implied, is granted under any patent right, copyright, mask work right, or other intellectual property right relating to any combination, machine, or process in which TI components or services are used. Information published by TI regarding third-party products or services does not constitute a license to use such products or services or a warranty or endorsement thereof. Use of such information may require a license from a third party under the patents or other intellectual property of the third party, or a license from TI under the patents or other intellectual property of TI.

Reproduction of significant portions of TI information in TI data books or data sheets is permissible only if reproduction is without alteration and is accompanied by all associated warranties, conditions, limitations, and notices. TI is not responsible or liable for such altered documentation. Information of third parties may be subject to additional restrictions.

Resale of TI components or services with statements different from or beyond the parameters stated by TI for that component or service voids all express and any implied warranties for the associated TI component or service and is an unfair and deceptive business practice. TI is not responsible or liable for any such statements.

Buyer acknowledges and agrees that it is solely responsible for compliance with all legal, regulatory and safety-related requirements concerning its products, and any use of TI components in its applications, notwithstanding any applications-related information or support that may be provided by TI. Buyer represents and agrees that it has all the necessary expertise to create and implement safeguards which anticipate dangerous consequences of failures, monitor failures and their consequences, lessen the likelihood of failures that might cause harm and take appropriate remedial actions. Buyer will fully indemnify TI and its representatives against any damages arising out of the use of any TI components in safety-critical applications.

In some cases, TI components may be promoted specifically to facilitate safety-related applications. With such components, TI's goal is to help enable customers to design and create their own end-product solutions that meet applicable functional safety standards and requirements. Nonetheless, such components are subject to these terms.

No TI components are authorized for use in FDA Class III (or similar life-critical medical equipment) unless authorized officers of the parties have executed a special agreement specifically governing such use.

Only those TI components which TI has specifically designated as military grade or "enhanced plastic" are designed and intended for use in military/aerospace applications or environments. Buyer acknowledges and agrees that any military or aerospace use of TI components which have **not** been so designated is solely at the Buyer's risk, and that Buyer is solely responsible for compliance with all legal and regulatory requirements in connection with such use.

TI has specifically designated certain components as meeting ISO/TS16949 requirements, mainly for automotive use. In any case of use of non-designated products, TI will not be responsible for any failure to meet ISO/TS16949.

### Products

|                              |  |
|------------------------------|--|
| Audio                        | <a href="http://www.ti.com/audio">www.ti.com/audio</a>                               |
| Amplifiers                   | <a href="http://amplifier.ti.com">amplifier.ti.com</a>                               |
| Data Converters              | <a href="http://dataconverter.ti.com">dataconverter.ti.com</a>                       |
| DLP® Products                | <a href="http://www.dlp.com">www.dlp.com</a>   |
| DSP                          | <a href="http://dsp.ti.com">dsp.ti.com</a>   |
| Clocks and Timers            | <a href="http://www.ti.com/clocks">www.ti.com/clocks</a>                             |
| Interface                    | <a href="http://interface.ti.com">interface.ti.com</a>                               |
| Logic                        | <a href="http://logic.ti.com">logic.ti.com</a>                                       |
| Power Mgmt                   | <a href="http://power.ti.com">power.ti.com</a>                                       |
| Microcontrollers             | <a href="http://microcontroller.ti.com">microcontroller.ti.com</a>                   |
| RFID                         | <a href="http://www.ti-rfid.com">www.ti-rfid.com</a>                                 |
| OMAP Applications Processors | <a href="http://www.ti.com/omap">www.ti.com/omap</a>                                 |
| Wireless Connectivity        | <a href="http://www.ti.com/wirelessconnectivity">www.ti.com/wirelessconnectivity</a> |

### Applications

|                               |  |
|-------------------------------|--|
| Automotive and Transportation | <a href="http://www.ti.com/automotive">www.ti.com/automotive</a>                         |
| Communications and Telecom    | <a href="http://www.ti.com/communications">www.ti.com/communications</a>                 |
| Computers and Peripherals     | <a href="http://www.ti.com/computers">www.ti.com/computers</a>                           |
| Consumer Electronics          | <a href="http://www.ti.com/consumer-apps">www.ti.com/consumer-apps</a>                   |
| Energy and Lighting           | <a href="http://www.ti.com/energy">www.ti.com/energy</a>                                 |
| Industrial                    | <a href="http://www.ti.com/industrial">www.ti.com/industrial</a>                         |
| Medical                       | <a href="http://www.ti.com/medical">www.ti.com/medical</a>                               |
| Security                      | <a href="http://www.ti.com/security">www.ti.com/security</a>                             |
| Space, Avionics and Defense   | <a href="http://www.ti.com/space-avionics-defense">www.ti.com/space-avionics-defense</a> |
| Video and Imaging             | <a href="http://www.ti.com/video">www.ti.com/video</a>                                   |

### TI E2E Community

[e2e.ti.com](http://e2e.ti.com)