

# LM1896,LM2896

*LM1896 LM2896 Dual Audio Power Amplifier*



Literature Number: SNAS552A

## LM1896/LM2896 Dual Audio Power Amplifier

### General Description

The LM1896 is a high performance 6V stereo power amplifier designed to deliver 1 watt/channel into 4Ω or 2 watts bridged monaural into 8Ω. Utilizing a unique patented compensation scheme, the LM1896 is ideal for sensitive AM radio applications. This new circuit technique exhibits lower wideband noise, lower distortion, and less AM radiation than conventional designs. The amplifier's wide supply range (3V–9V) is ideal for battery operation. For higher supplies ( $V_S > 9V$ ) the LM2896 is available in an 11-lead single-inline package. The LM2896 package has been redesigned, resulting in the slightly degraded thermal characteristics shown in the figure Device Dissipation vs Ambient Temperature.

### Features

- Low AM radiation
- Low noise
- 3V, 4Ω, stereo  $P_o = 250$  mW
- Wide supply operation 3V–15V (LM2896)
- Low distortion
- No turn on "pop"
- Adjustable voltage gain and bandwidth
- Smooth waveform clipping
- $P_o = 9W$  bridged, LM2896

### Applications

- Compact AM-FM radios
- Stereo tape recorders and players
- High power portable stereos

### Typical Applications

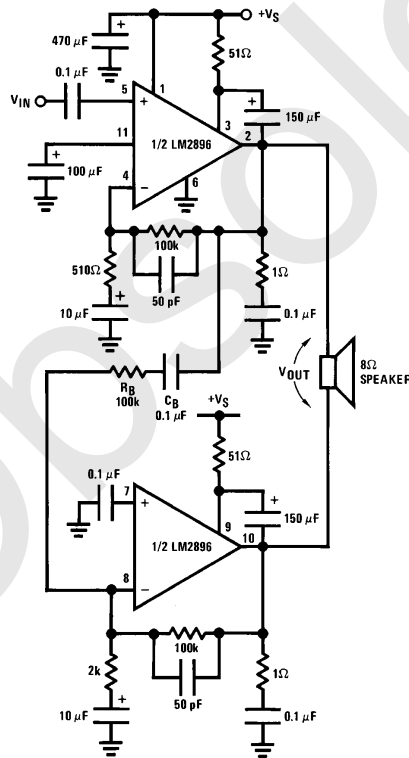

TL/H/7920-1

FIGURE 1. LM2896 in Bridge Configuration ( $A_V = 400$ ,  $BW = 20$  kHz)

Order Number LM1896N

Order Number LM2896P

See NS Package Number N14A

See NS Package Number P11A

## Absolute Maximum Ratings

If Military/Aerospace specified devices are required, please contact the National Semiconductor Sales Office/Distributors for availability and specifications.

Supply Voltage	
LM1896	$V_S = 12V$
LM2896	$V_S = 18V$
Operating Temperature (Note 1)	$0^\circ C$ to $+70^\circ C$
Storage Temperature	$-65^\circ C$ to $+150^\circ C$

Junction Temperature	$150^\circ C$
Lead Temperature (Soldering, 10 sec.)	$260^\circ C$
Thermal Resistance	
$\theta_{JC}$ (DIP)	$30^\circ C/W$
$\theta_{JA}$ (DIP)	$137^\circ C/W$
$\theta_{JC}$ (SIP)	$10^\circ C/W$
$\theta_{JA}$ (SIP)	$55^\circ C/W$

## Electrical Characteristics

Unless otherwise specified,  $T_A = 25^\circ C$ ,  $A_V = 200$  (46 dB). For the LM1896;  $V_S = 6V$  and  $R_L = 4\Omega$ . For LM2896,  $T_{TAB} = 25^\circ C$ ,  $V_S = 12V$  and  $R_L = 8\Omega$ . Test circuit shown in Figure 2.

Parameter	Conditions	LM1896			LM2896			Units
		Min	Typ	Max	Min	Typ	Max	
Supply Current	$P_o = 0W$ , Dual Mode		15	25		25	40	mA
Operating Supply Voltage		3		10	3		15	V
Output Power	THD = 10%, $f = 1$ kHz							
LM1896N-1	$V_S = 6V$ , $R_L = 4\Omega$ Dual Mode	0.9	1.1					W/ch
LM1896N-2	$V_S = 6V$ , $R_L = 8\Omega$ Bridge Mode		1.8	2.1				W
	$V_S = 9V$ , $R_L = 8\Omega$ Dual Mode		1.3					W/ch
LM2896P-1	$V_S = 12V$ , $R_L = 8\Omega$ Dual Mode				2.0	2.5		W/ch
LM2896P-2	$V_S = 12V$ , $R_L = 8\Omega$ Bridge Mode				7.2	9.0		W
	$V_S = 9V$ , $R_L = 4\Omega$ Bridge Mode					7.8		W
	$V_S = 9V$ , $R_L = 4\Omega$ Dual Mode					2.5		W/ch
Distortion	$f = 1$ kHz $P_o = 50$ mW $P_o = 0.5W$ $P_o = 1W$		0.09 0.11			0.09 0.11 0.14		% % %
Power Supply Rejection Ratio (PSRR)	$C_{BY} = 100 \mu F$ , $f = 1$ kHz, $C_{IN} = 0.1 \mu F$ Output Referred, $V_{RIPPLE} = 250$ mV	-40	-54		-40	-54		dB
Channel Separation	$C_{BY} = 100 \mu F$ , $f = 1$ kHz, $C_{IN} = 0.1 \mu F$ Output Referred	-50	-64		-50	-64		dB
Noise	Equivalent Input Noise $R_S = 0$ , $C_{IN} = 0.1 \mu F$ , BW = 20 – 20 kHz CCIR/ARM Wideband		1.4 1.4 2.0			1.4 1.4 2.0		$\mu V$ $\mu V$ $\mu V$
DC Output Level		2.8	3	3.2	5.6	6	6.4	V
Input Impedance		50	100	350	50	100	350	k $\Omega$
Input Offset Voltage			5			5		mV
Voltage Difference between Outputs	LM1896N-2, LM2896P-2		10	20		10	20	mV
Input Bias Current			120			120		nA

**Note 1:** For operation at ambient temperature greater than  $25^\circ C$ , the LM1896/LM2896 must be derated based on a maximum  $150^\circ C$  junction temperature using a thermal resistance which depends upon mounting techniques.

# Typical Performance Curves

**LM2896 Device Dissipation vs Ambient Temperature**

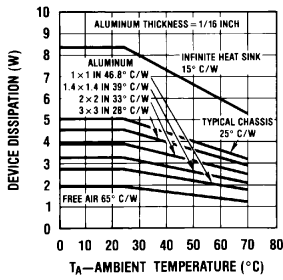

**LM1896 Maximum Device Dissipation vs Ambient Temperature**

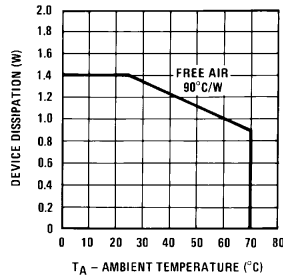

**-3 dB Bandwidth vs Voltage Gain for Stable Operation**

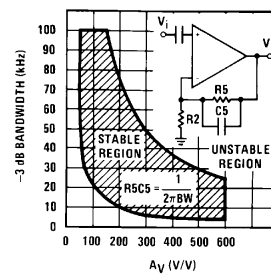

**THD and Gain vs Frequency  
 $A_V = 54$  dB, BW = 30 kHz**

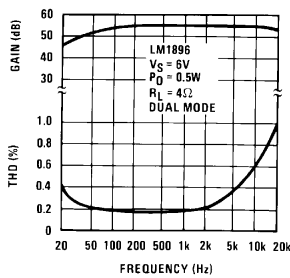

**THD and Gain vs Frequency  
 $A_V = 54$  dB, BW = 5 kHz**

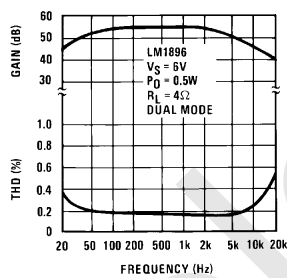

**THD and Gain vs Frequency  
 $A_V = 46$  dB, BW = 50 kHz**

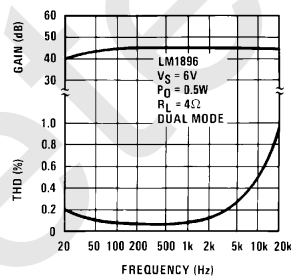

**THD and Gain vs Frequency  
 $A_V = 40$  dB, BW = 20 kHz**

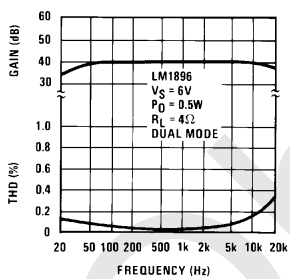

**THD and Gain vs Frequency  
 $A_V = 34$  dB, BW = 50 kHz**

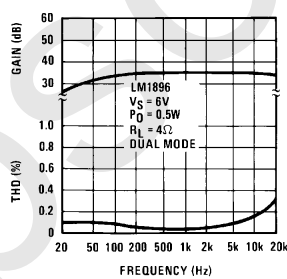

**AM Recovered Audio and Noise vs Field Strength for Different Speaker Lead Placement**

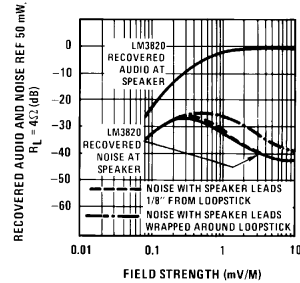

**Power Supply Rejection Ratio (Referred to the Output) vs Frequency**

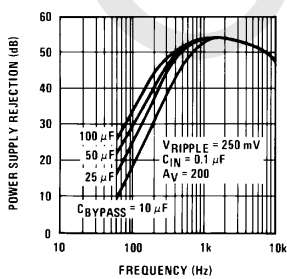

**Channel Separation (Referred to the Output) vs Frequency**

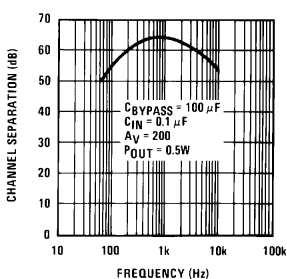

**Power Output vs Supply Voltage**

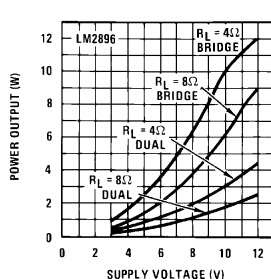

## Typical Performance Curves (Continued)

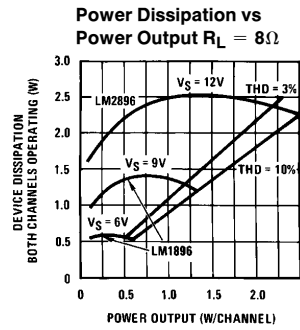
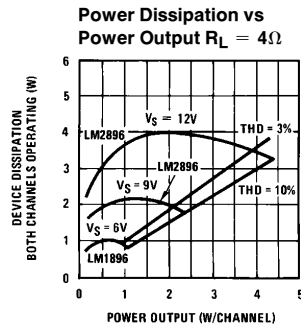
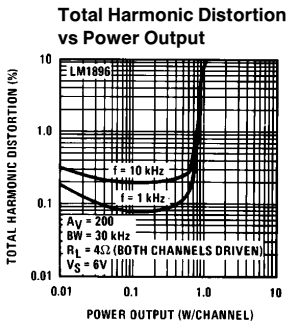

TL/H/7920-3

## Equivalent Schematic

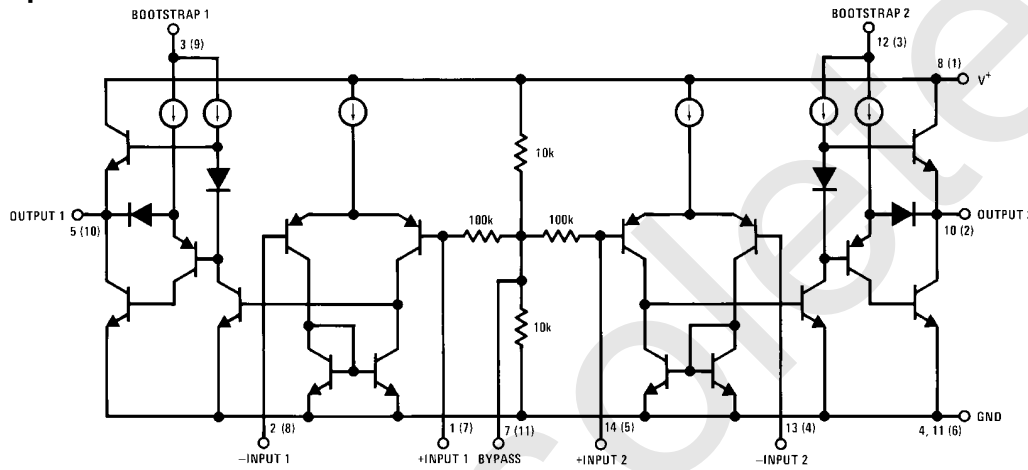

6, 9 No connection on LM1896

( ) indicates pin number for LM2896

TL/H/7920-4

## Connection Diagrams

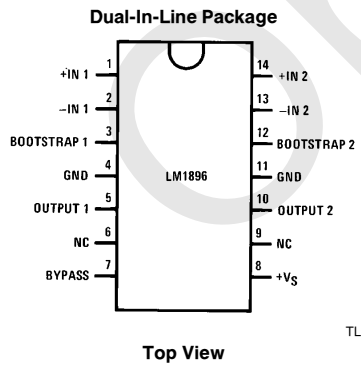

TL/H/7920-5

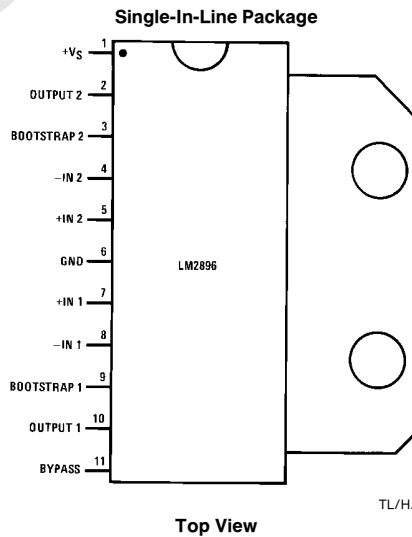

TL/H/7920-6

## Typical Applications (Continued)

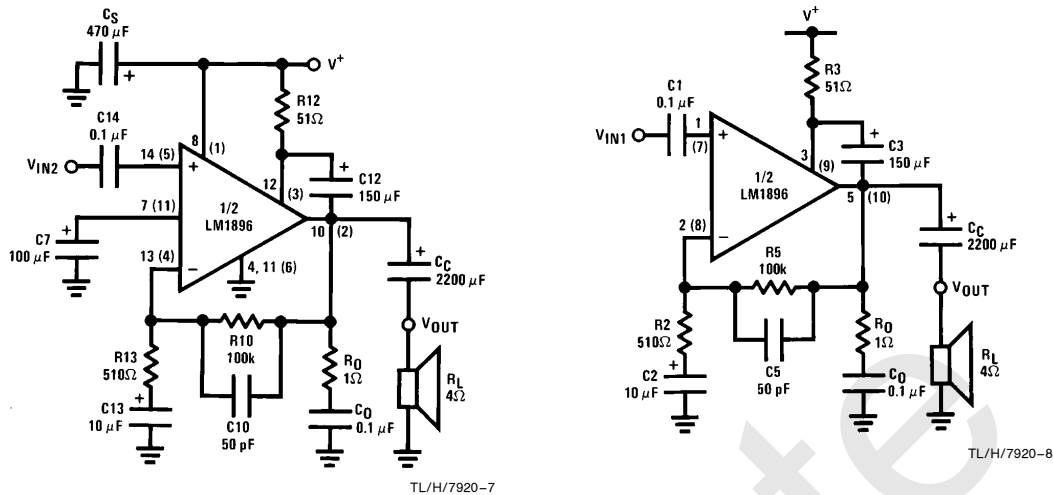

6, 9 No connection on LM1896  
 ( ) Indicates pin number for LM2896

FIGURE 2. Stereo Amplifier with  $A_V = 200$ ,  $BW = 30$  kHz

## External Components (Figure 2)

Components	Comments
1. R2, R5, R10, R13	Sets voltage gain, $A_V = 1 + R5/R2$ for one channel and $A_V = 1 + R10/R13$ for the other channel.
2. R3, R12	Bootstrap resistor sets drive current for output stage and allows pins 3 and 12 to go above $V_S$ .
3. $R_O$	Works with $C_O$ to stabilize output stage.
4. C1, C14	Input coupling capacitor. Pins 1 and 14 are at a DC potential of $V_S/2$ . Low frequency pole set by: $f_L = \frac{1}{2\pi R_{IN} C1}$
5. C2, C13	Feedback capacitors. Ensure unity gain at DC. Also a low frequency pole at: $f_L = \frac{1}{2\pi R2 C2}$
6. C3, C12	Bootstrap capacitors, used to increase drive to output stage. A low frequency pole is set by: $f_L = \frac{1}{2\pi R3 C3}$
7. C5, C10	Compensation capacitor. These stabilize the amplifiers and adjust their bandwidth. See curve of bandwidth vs allowable gain.
8. C7	Improves power supply rejection (See Typical Performance Curves). Increasing C7 increases turn-on delay.
9. $C_C$	Output coupling capacitor. Isolates pins 5 and 10 from the load. Low frequency pole set by: $f_L = \frac{1}{2\pi C_C R_L}$
10. $C_O$	Works with $R_O$ to stabilize output stage.
11. $C_S$	Provides power supply filtering.

## Application Hints

### AM Radios

The LM1896/LM2896 has been designed to fill a wide range of audio power applications. A common problem with IC audio power amplifiers has been poor signal-to-noise performance when used in AM radio applications. In a typical radio application, the loopstick antenna is in close proximity to the audio amplifier. Current flowing in the speaker and power supply leads can cause electromagnetic coupling to the loopstick, resulting in system oscillation. In addition, most audio power amplifiers are not optimized for lowest noise because of compensation requirements. If noise from the audio amplifier radiates into the AM section, the sensitivity and signal-to-noise ratio will be degraded.

The LM1896 exhibits extremely low wideband noise due in part to an external capacitor C5 which is used to tailor the bandwidth. The circuit shown in *Figure 2* is capable of a signal-to-noise ratio in excess of 60 dB referred to 50 mW. Capacitor C5 not only limits the closed loop bandwidth, it also provides overall loop compensation. Neglecting C2 in *Figure 2*, the gain is:

$$A_V(S) = \frac{S + A_V \omega_o}{S + \omega_o}$$

$$\text{where } A_V = \frac{R_2 + R_5}{R_2}, \quad \omega_o = \frac{1}{R_5 C_5}$$

A curve of  $-3$  dB BW ( $\omega_o$ ) vs  $A_V$  is shown in the Typical Performance Curves.

*Figure 3* shows a plot of recovered audio as a function of field strength in  $\mu\text{V}/\text{M}$ . The receiver section in this example is an LM3820. The power amplifier is located about two inches from the loopstick antenna. Speaker leads run parallel to the loopstick and are  $1/8$  inch from it. Referenced to a 20 dB S/N ratio, the improvement in noise performance over conventional designs is about 10 dB. This corresponds to an increase in usable sensitivity of about 8.5 dB.

### Bridge Amplifiers

The LM1896/LM2896 can be used in the bridge mode as a monaural power amplifier. In addition to much higher power output, the bridge configuration does not require output coupling capacitors. The load is connected directly between the amplifier outputs as shown in *Figure 4*.

Amp 1 has a voltage gain set by  $1 + R_5/R_2$ . The output of amp 1 drives amp 2 which is configured as an inverting amplifier with unity gain. Because of this phase inversion in amp 2, there is a 6 dB increase in voltage gain referenced to  $V_i$ . The voltage gain in bridge is:

$$\frac{V_o}{V_i} = 2 \left( 1 + \frac{R_5}{R_2} \right)$$

$C_B$  is used to prevent DC voltage on the output of amp 1 from causing offset in amp 2. Low frequency response is influenced by:

$$f_L = \frac{1}{2\pi R_B C_B}$$

Several precautions should be observed when using the LM1896/LM2896 in bridge configuration. Because the amplifiers are driving the load out of phase, an  $8\Omega$  speaker will appear as a  $4\Omega$  load, and a  $4\Omega$  speaker will appear as a  $2\Omega$  load. Power dissipation is twice as severe in this situation. For example, if  $V_S = 6\text{V}$  and  $R_L = 8\Omega$  bridged, then the maximum dissipation is:

$$P_D = \frac{V_S^2}{20 R_L} \times 2 = \frac{6^2}{20 \times 4} \times 2$$

$$P_D = 0.9 \text{ Watts}$$

This amount of dissipation is equivalent to driving two  $4\Omega$  loads in the stereo configuration.

When adjusting the frequency response in the bridge configuration,  $R_5 C_5$  and  $R_{10} C_{10}$  form a 2 pole cascade and the  $-3$  dB bandwidth is actually shifted to a lower frequency:

$$BW = \frac{0.707}{2\pi RC}$$

where R = feedback resistor  
C = feedback capacitor

To measure the output voltage, a floating or differential meter should be used because a prolonged output short will over dissipate the package. *Figure 1* shows the complete bridge amplifier.

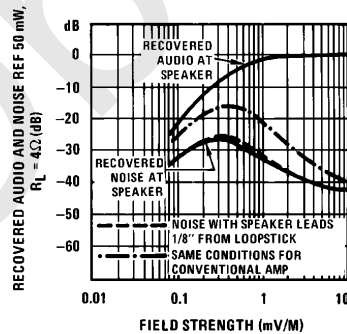

FIGURE 3. Improved AM Sensitivity over Conventional Design

TL/H/7920-9

## Application Hints (Continued)

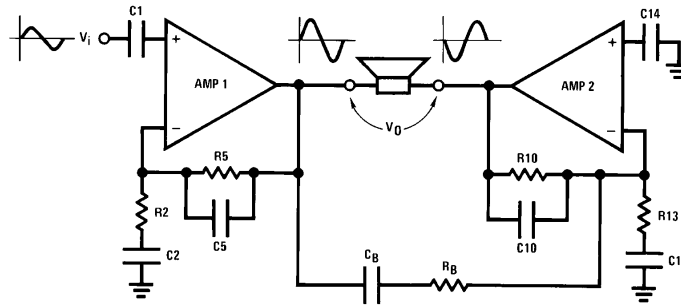

Figure 4. Bridge Amplifier Connection

TL/H/7920-10

## Printed Circuit Layout

### Printed Circuit Board Layout

Figure 5 and Figure 6 show printed circuit board layouts for the LM1896 and LM2896. The circuits are wired as stereo amplifiers. The signal source ground should return to the input ground shown on the boards. Returning the loads to power supply ground through a separate wire will keep the THD at its lowest value. The inputs should be terminated in

less than  $50\text{ k}\Omega$  to prevent an input-output oscillation. This oscillation is dependent on the gain and the proximity of the bridge elements  $R_B$  and  $C_B$  to the (+) input. If the bridge mode is not used, do not insert  $R_B$ ,  $C_B$  into the PCB.

To wire the amplifier into the bridge configuration, short the capacitor on pin 7 (pin 1 of the LM1896) to ground. Connect together the nodes labeled BRIDGE and drive the capacitor connected to pin 5 (pin 14 of the LM1896).

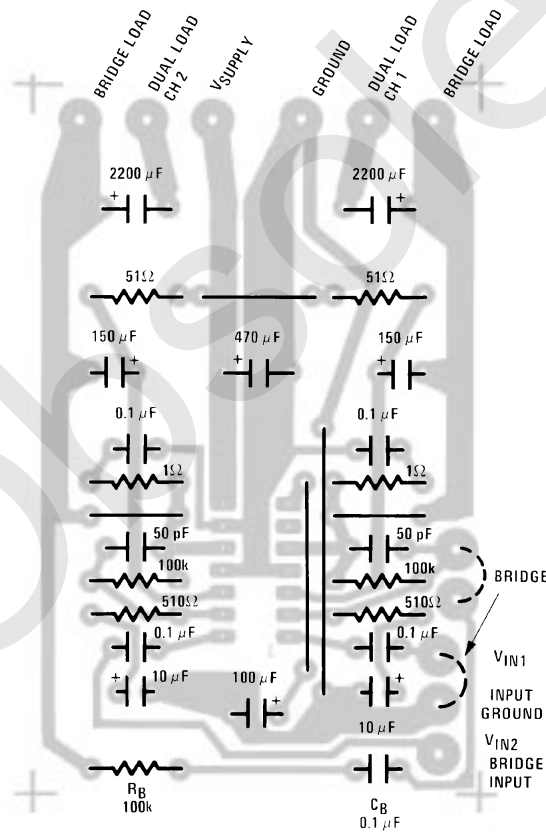

FIGURE 5. Printed Circuit Board Layout for the LM1896

TL/H/7920-11



Printed Circuit Layout (Continued)

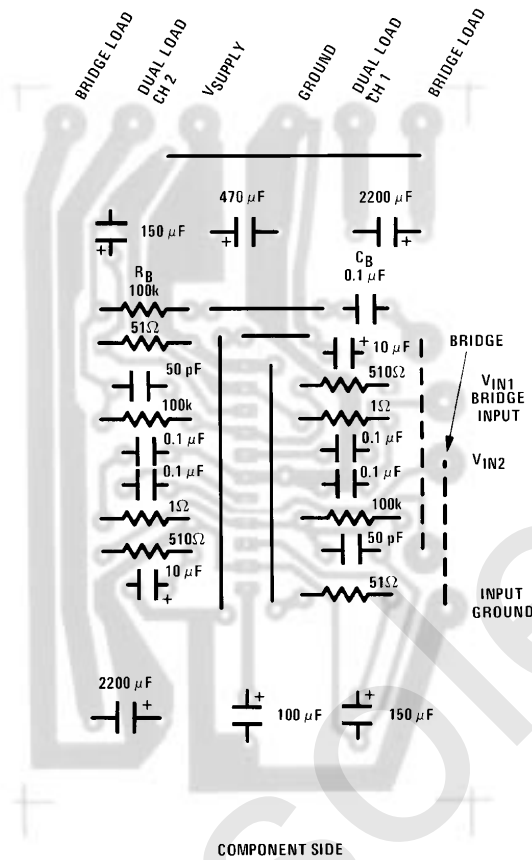
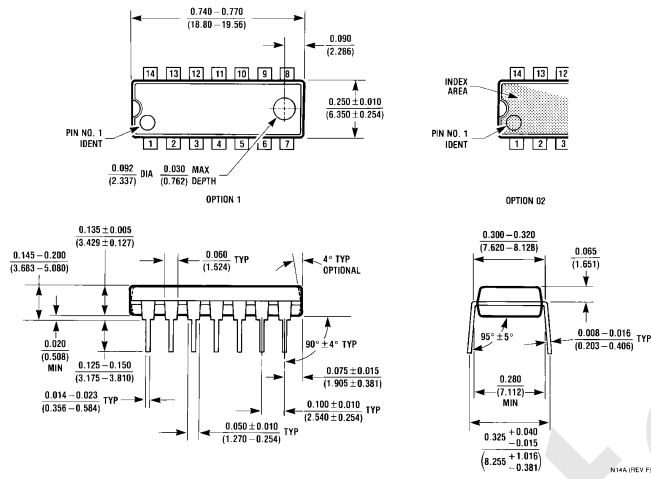

FIGURE 6. Printed Circuit Board Layout for the LM2896

TL/H/7920-12

**Physical Dimensions** inches (millimeters)



**Molded Dual-In-Line Package (N)**  
**Order Number LM1896N**  
**See NS Package Number N14A**

**Physical Dimensions** inches (millimeters) (Continued)

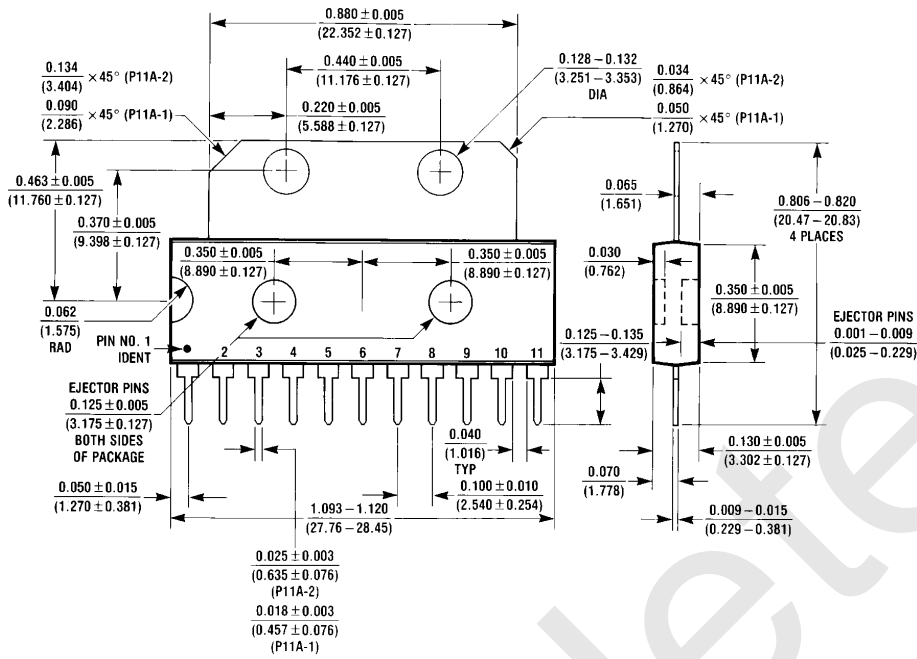

Single-In-Line Package (P)  
 Order Number LM2896P  
 NS Package Number P11A

**LIFE SUPPORT POLICY**

NATIONAL'S PRODUCTS ARE NOT AUTHORIZED FOR USE AS CRITICAL COMPONENTS IN LIFE SUPPORT DEVICES OR SYSTEMS WITHOUT THE EXPRESS WRITTEN APPROVAL OF THE PRESIDENT OF NATIONAL SEMICONDUCTOR CORPORATION. As used herein:

1. Life support devices or systems are devices or systems which, (a) are intended for surgical implant into the body, or (b) support or sustain life, and whose failure to perform, when properly used in accordance with instructions for use provided in the labeling, can be reasonably expected to result in a significant injury to the user.
2. A critical component is any component of a life support device or system whose failure to perform can be reasonably expected to cause the failure of the life support device or system, or to affect its safety or effectiveness.

 <p><b>National Semiconductor Corporation</b>                      1111 West Bardin Road                      Arlington, TX 76017                      Tel: (800) 272-9959                      Fax: (800) 737-7018</p>	<p><b>National Semiconductor Europe</b>                      Fax: (+49) 0-180-530 85 86                      Email: cnjwge@tevm2.nsc.com                      Deutsch Tel: (+49) 0-180-530 85 85                      English Tel: (+49) 0-180-532 78 32                      Français Tel: (+49) 0-180-532 93 58                      Italiano Tel: (+49) 0-180-534 16 80</p>	<p><b>National Semiconductor Hong Kong Ltd.</b>                      19th Floor, Straight Block,                      Ocean Centre, 5 Canton Rd.                      Tsimshatsui, Kowloon                      Hong Kong                      Tel: (852) 2737-1600                      Fax: (852) 2736-9960</p>	<p><b>National Semiconductor Japan Ltd.</b>                      Tel: 81-043-299-2309                      Fax: 81-043-299-2408</p>
--	--	---	---

National does not assume any responsibility for use of any circuitry described, no circuit patent licenses are implied and National reserves the right at any time without notice to change said circuitry and specifications.

## IMPORTANT NOTICE

Texas Instruments Incorporated and its subsidiaries (TI) reserve the right to make corrections, modifications, enhancements, improvements, and other changes to its products and services at any time and to discontinue any product or service without notice. Customers should obtain the latest relevant information before placing orders and should verify that such information is current and complete. All products are sold subject to TI's terms and conditions of sale supplied at the time of order acknowledgment.

TI warrants performance of its hardware products to the specifications applicable at the time of sale in accordance with TI's standard warranty. Testing and other quality control techniques are used to the extent TI deems necessary to support this warranty. Except where mandated by government requirements, testing of all parameters of each product is not necessarily performed.

TI assumes no liability for applications assistance or customer product design. Customers are responsible for their products and applications using TI components. To minimize the risks associated with customer products and applications, customers should provide adequate design and operating safeguards.

TI does not warrant or represent that any license, either express or implied, is granted under any TI patent right, copyright, mask work right, or other TI intellectual property right relating to any combination, machine, or process in which TI products or services are used. Information published by TI regarding third-party products or services does not constitute a license from TI to use such products or services or a warranty or endorsement thereof. Use of such information may require a license from a third party under the patents or other intellectual property of the third party, or a license from TI under the patents or other intellectual property of TI.

Reproduction of TI information in TI data books or data sheets is permissible only if reproduction is without alteration and is accompanied by all associated warranties, conditions, limitations, and notices. Reproduction of this information with alteration is an unfair and deceptive business practice. TI is not responsible or liable for such altered documentation. Information of third parties may be subject to additional restrictions.

Resale of TI products or services with statements different from or beyond the parameters stated by TI for that product or service voids all express and any implied warranties for the associated TI product or service and is an unfair and deceptive business practice. TI is not responsible or liable for any such statements.

TI products are not authorized for use in safety-critical applications (such as life support) where a failure of the TI product would reasonably be expected to cause severe personal injury or death, unless officers of the parties have executed an agreement specifically governing such use. Buyers represent that they have all necessary expertise in the safety and regulatory ramifications of their applications, and acknowledge and agree that they are solely responsible for all legal, regulatory and safety-related requirements concerning their products and any use of TI products in such safety-critical applications, notwithstanding any applications-related information or support that may be provided by TI. Further, Buyers must fully indemnify TI and its representatives against any damages arising out of the use of TI products in such safety-critical applications.

TI products are neither designed nor intended for use in military/aerospace applications or environments unless the TI products are specifically designated by TI as military-grade or "enhanced plastic." Only products designated by TI as military-grade meet military specifications. Buyers acknowledge and agree that any such use of TI products which TI has not designated as military-grade is solely at the Buyer's risk, and that they are solely responsible for compliance with all legal and regulatory requirements in connection with such use.

TI products are neither designed nor intended for use in automotive applications or environments unless the specific TI products are designated by TI as compliant with ISO/TS 16949 requirements. Buyers acknowledge and agree that, if they use any non-designated products in automotive applications, TI will not be responsible for any failure to meet such requirements.

Following are URLs where you can obtain information on other Texas Instruments products and application solutions:

### Products

Audio	<a href="http://www.ti.com/audio">www.ti.com/audio</a>
Amplifiers	<a href="http://amplifier.ti.com">amplifier.ti.com</a>
Data Converters	<a href="http://dataconverter.ti.com">dataconverter.ti.com</a>
DLP® Products	<a href="http://www.dlp.com">www.dlp.com</a>
DSP	<a href="http://dsp.ti.com">dsp.ti.com</a>
Clocks and Timers	<a href="http://www.ti.com/clocks">www.ti.com/clocks</a>
Interface	<a href="http://interface.ti.com">interface.ti.com</a>
Logic	<a href="http://logic.ti.com">logic.ti.com</a>
Power Mgmt	<a href="http://power.ti.com">power.ti.com</a>
Microcontrollers	<a href="http://microcontroller.ti.com">microcontroller.ti.com</a>
RFID	<a href="http://www.ti-rfid.com">www.ti-rfid.com</a>
OMAP Mobile Processors	<a href="http://www.ti.com/omap">www.ti.com/omap</a>
Wireless Connectivity	<a href="http://www.ti.com/wirelessconnectivity">www.ti.com/wirelessconnectivity</a>

### Applications

Communications and Telecom	<a href="http://www.ti.com/communications">www.ti.com/communications</a>
Computers and Peripherals	<a href="http://www.ti.com/computers">www.ti.com/computers</a>
Consumer Electronics	<a href="http://www.ti.com/consumer-apps">www.ti.com/consumer-apps</a>
Energy and Lighting	<a href="http://www.ti.com/energy">www.ti.com/energy</a>
Industrial	<a href="http://www.ti.com/industrial">www.ti.com/industrial</a>
Medical	<a href="http://www.ti.com/medical">www.ti.com/medical</a>
Security	<a href="http://www.ti.com/security">www.ti.com/security</a>
Space, Avionics and Defense	<a href="http://www.ti.com/space-avionics-defense">www.ti.com/space-avionics-defense</a>
Transportation and Automotive	<a href="http://www.ti.com/automotive">www.ti.com/automotive</a>
Video and Imaging	<a href="http://www.ti.com/video">www.ti.com/video</a>

TI E2E Community Home Page

[e2e.ti.com](http://e2e.ti.com)

Mailing Address: Texas Instruments, Post Office Box 655303, Dallas, Texas 75265  
Copyright © 2011, Texas Instruments Incorporated