

LM26LV/LM26LV-Q1 1.6 V, WSON-6 Factory Preset Temperature Switch and Temperature Sensor

Check for Samples: [LM26LV](#)

FEATURES

- Low 1.6V Operation
- Low Quiescent Current
- Latching Function: Device Can Latch the Over Temperature Condition
- Push-Pull and Open-Drain Temperature Switch Outputs
- Wide Trip Point Range of 0°C to 150°C
- Very Linear Analog V_{TEMP} Temperature Sensor Output
- V_{TEMP} Output Short-Circuit Protected
- Accurate Over –50°C to 150°C Temperature Range
- 2.2 mm by 2.5 mm (typ) WSON-6 Package
- Excellent Power Supply Noise Rejection
- LM26LVQISD–130 and LM26LVQISD-135 are AEC-Q100 Grade 0 Qualified and are Manufactured on an Automotive Grade Flow. For Other Trip Points, Contact Your Sales Office.

APPLICATIONS

- Cell Phones and Wireless Transceivers
- Digital Cameras
- Battery Management
- Automotive
- Disk Drives
- Games and Appliances

Key Specifications

Supply Voltage	1.6V to 5.5V	
Supply Current	8 μ A (typ)	
Accuracy, Trip Point Temperature	0°C to 150°C	\pm 2.2°C
Accuracy, V_{TEMP}	0°C to 150°C	\pm 2.3°C
	0°C to 120°C	\pm 2.2°C
	–50°C to 0°C	\pm 1.7°C
V_{TEMP} Output Drive	\pm 100 μ A	
Operating Temperature	–50°C to 150°C	
Hysteresis Temperature	4.5°C to 5.5°C	

DESCRIPTION

The LM26LV/LM26LV-Q1 is a low-voltage, precision, dual-output, low-power temperature switch and temperature sensor. The temperature trip point (T_{TRIP}) can be preset at the factory to any temperature in the range of 0°C to 150°C in 1°C increments. Built-in temperature hysteresis (T_{HYST}) keeps the output stable in an environment of temperature instability.

In normal operation the LM26LV/LM26LV-Q1 temperature switch outputs assert when the die temperature exceeds T_{TRIP} . The temperature switch outputs will reset when the temperature falls below a temperature equal to ($T_{TRIP} - T_{HYST}$). The $\overline{OVERTEMP}$ digital output, is active-high with a push-pull structure, while the $\overline{OVERTEMP}$ digital output, is active-low with an open-drain structure.

The analog output, V_{TEMP} , delivers an analog output voltage with Negative Temperature Coefficient (NTC).

Driving the TRIP TEST input high: (1) causes the digital outputs to be asserted for in-situ verification and, (2) causes the threshold voltage to appear at the V_{TEMP} output pin, which could be used to verify the temperature trip point.

The LM26LV/LM26LV-Q1's low minimum supply voltage makes it ideal for 1.8 Volt system designs. Its wide operating range, low supply current, and excellent accuracy provide a temperature switch solution for a wide range of commercial and industrial applications.



Please be aware that an important notice concerning availability, standard warranty, and use in critical applications of Texas Instruments semiconductor products and disclaimers thereto appears at the end of this data sheet.

All trademarks are the property of their respective owners.

Connection Diagram

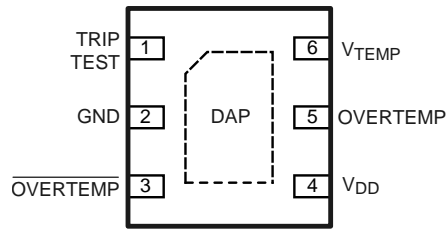

Figure 1. WSON-6 (Top View)
See Package Number NGF0006A

Typical Transfer Characteristic

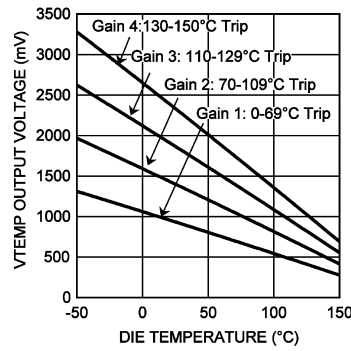
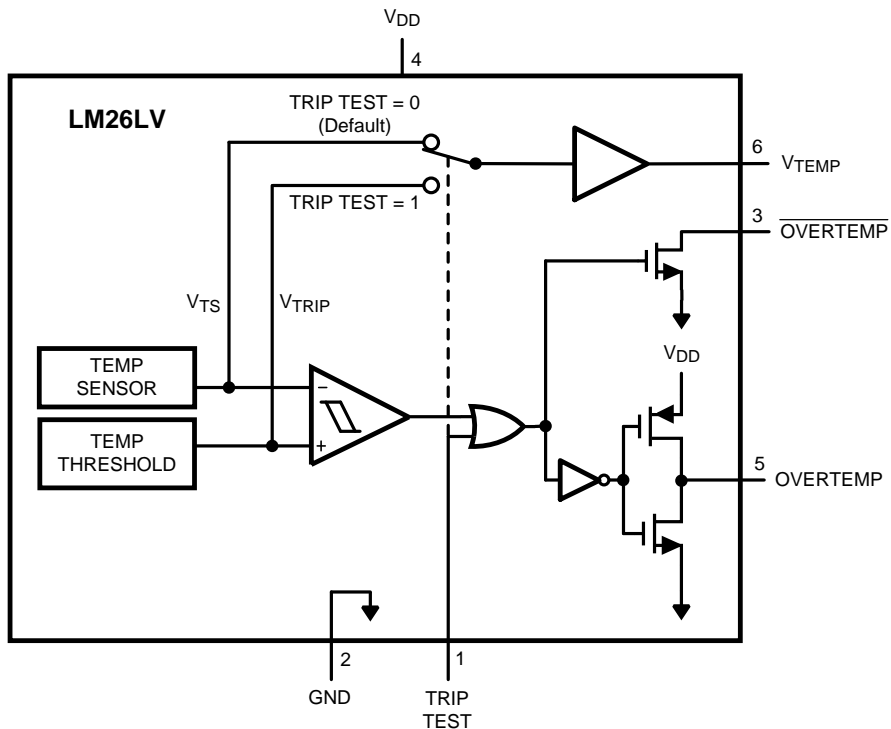
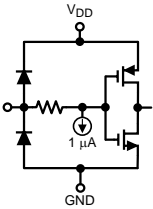
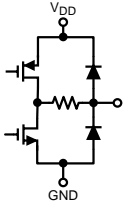
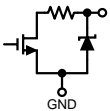
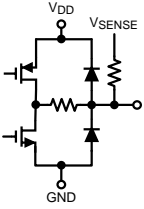

Figure 2. V_{TEMP} Analog Voltage vs Die Temperature

Block Diagram



Pin Descriptions

Pin No.	Name	Type	Equivalent Circuit	Description
1	TRIP TEST	Digital Input		<p>TRIP TEST pin. Active High input.</p> <p>If TRIP TEST = 0 (Default) then: $V_{TEMP} = V_{TS}$, Temperature Sensor Output Voltage</p> <p>If TRIP TEST = 1 then: $\overline{OVERTEMP}$ and $\overline{OVERTEMP}$ outputs are asserted and $V_{TEMP} = V_{TRIP}$, Temperature Trip Voltage.</p> <p>This pin may be left open if not used.</p>
5	OVERTEMP	Digital Output		<p>Over Temperature Switch output</p> <p>Active High, Push-Pull</p> <p>Asserted when the measured temperature exceeds the Trip Point Temperature or if TRIP TEST = 1</p> <p>This pin may be left open if not used.</p>
3	$\overline{OVERTEMP}$	Digital Output		<p>Over Temperature Switch output</p> <p>Active Low, Open-drain (See Determining the Pull-up Resistor Value)</p> <p>Asserted when the measured temperature exceeds the Trip Point Temperature or if TRIP TEST = 1</p> <p>This pin may be left open if not used.</p>
6	V_{TEMP}	Analog Output		<p>V_{TEMP} Analog Voltage Output</p> <p>If TRIP TEST = 0 then $V_{TEMP} = V_{TS}$, Temperature Sensor Output Voltage</p> <p>If TRIP TEST = 1 then $V_{TEMP} = V_{TRIP}$, Temperature Trip Voltage</p> <p>This pin may be left open if not used.</p>
4	V_{DD}	Power		Positive Supply Voltage
2	GND	Ground		Power Supply Ground
DAP	Die Attach Pad			The best thermal conductivity between the device and the PCB is achieved by soldering the DAP of the package to the thermal pad on the PCB. The thermal pad can be a floating node. However, for improved noise immunity the thermal pad should be connected to the circuit GND node, preferably directly to pin 2 (GND) of the device.

Typical Application

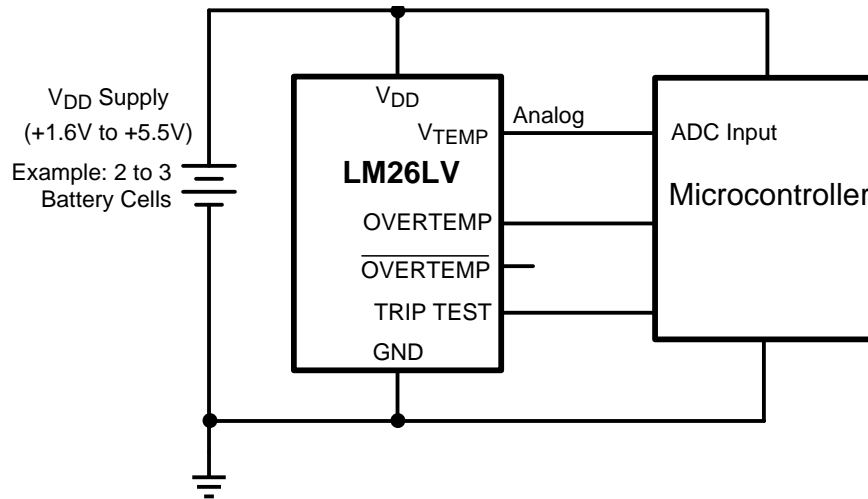

These devices have limited built-in ESD protection. The leads should be shorted together or the device placed in conductive foam during storage or handling to prevent electrostatic damage to the MOS gates.

Absolute Maximum Ratings⁽¹⁾

Supply Voltage		-0.3V to +6.0V
Voltage at $\overline{\text{OVERTEMP}}$ pin		-0.3V to +6.0V
Voltage at $\overline{\text{OVERTEMP}}$ and V _{TEMP} pins		-0.3V to (V _{DD} + 0.5V)
TRIP TEST Input Voltage		-0.3V to (V _{DD} + 0.5V)
Output Current, any output pin		±7 mA
Input Current at any pin ⁽²⁾		5 mA
Storage Temperature		-65°C to +150°C
Maximum Junction Temperature, T _{J(MAX)}		+155°C
ESD Susceptibility ⁽³⁾	Human Body Model	4500V
	Machine Model	300V
	Charged Device Model	1000V

For soldering specifications: see product folder at www.ti.com and <http://www.ti.com/lit/SNOA549>

- (1) Absolute Maximum Ratings indicate limits beyond which damage to the device may occur. Operating Ratings indicate conditions for which the device is functional, but do not guarantee specific performance limits. For guaranteed specifications and test conditions, see the [Electrical Characteristics](#). The guaranteed specifications apply only for the test conditions listed. Some performance characteristics may degrade when the device is not operated under the listed test conditions.
- (2) When the input voltage (V_I) at any pin exceeds power supplies (V_I < GND or V_I > V_{DD}), the current at that pin should be limited to 5mA.
- (3) The Human Body Model (HBM) is a 100pF capacitor charged to the specified voltage then discharged through a 1.5kΩ resistor into each pin. The Machine Model (MM) is a 200pF capacitor charged to the specified voltage then discharged directly into each pin. The Charged Device Model (CDM) is a specified circuit characterizing an ESD event that occurs when a device acquires charge through some triboelectric (frictional) or electrostatic induction processes and then abruptly touches a grounded object or surface.

Operating Ratings⁽¹⁾

Specified Temperature Range:		T _{MIN} ≤ T _A ≤ T _{MAX}
LM26LV/LM26LV-Q1		-50°C ≤ T _A ≤ +150°C
Supply Voltage Range (V _{DD})		+1.6 V to +5.5 V
Thermal Resistance (θ _{JA}) ⁽²⁾	WS0N-6 (Package NGF0006A)	152 °C/W

- (1) Absolute Maximum Ratings indicate limits beyond which damage to the device may occur. Operating Ratings indicate conditions for which the device is functional, but do not guarantee specific performance limits. For guaranteed specifications and test conditions, see the [Electrical Characteristics](#). The guaranteed specifications apply only for the test conditions listed. Some performance characteristics may degrade when the device is not operated under the listed test conditions.
- (2) The junction to ambient temperature resistance (θ_{JA}) is specified without a heat sink in still air.

Accuracy Characteristics Trip Point Accuracy

Parameter	Conditions		Limits ⁽¹⁾	Units (Limit)
Trip Point Accuracy ⁽²⁾	0 – 150°C	V _{DD} = 5.0 V	±2.2	°C (max)

(1) Limits are guaranteed to TI's AOQL (Average Outgoing Quality Level).

(2) Accuracy is defined as the error between the measured and reference output voltages, tabulated in the [Conversion Table](#) at the specified conditions of supply gain setting, voltage, and temperature (expressed in °C). Accuracy limits include line regulation within the specified conditions. Accuracy limits do not include load regulation; they assume no DC load.

Accuracy Characteristics V_{TEMP} Analog Temperature Sensor Output Accuracy⁽¹⁾

There are four gains corresponding to each of the four Temperature Trip Point Ranges. Gain 1 is the sensor gain used for Temperature Trip Point 0 - 69°C. Likewise Gain 2 is for Trip Points 70 - 109 °C; Gain 3 for 110 - 129 °C; and Gain 4 for 130 - 150 °C. These limits do not include DC load regulation. These stated accuracy limits are with reference to the values in the LM26LV/LM26LV-Q1 [Conversion Table](#).

Parameter	Conditions		Limits ⁽²⁾	Units (Limit)	
V_{TEMP} Temperature Accuracy ⁽³⁾	Gain 1: for Trip Point Range 0 - 69°C	$T_A = 20^\circ\text{C}$ to 40°C	$V_{DD} = 1.6$ to 5.5 V	± 1.8	°C (max)
		$T_A = 0^\circ\text{C}$ to 70°C	$V_{DD} = 1.6$ to 5.5 V	± 2.0	
		$T_A = 0^\circ\text{C}$ to 90°C	$V_{DD} = 1.6$ to 5.5 V	± 2.1	
		$T_A = 0^\circ\text{C}$ to 120°C	$V_{DD} = 1.6$ to 5.5 V	± 2.2	
		$T_A = 0^\circ\text{C}$ to 150°C	$V_{DD} = 1.6$ to 5.5 V	± 2.3	
		$T_A = -50^\circ\text{C}$ to 0°C	$V_{DD} = 1.7$ to 5.5 V	± 1.7	
	Gain 2: for Trip Point Range 70 - 109°C	$T_A = 20^\circ\text{C}$ to 40°C	$V_{DD} = 1.8$ to 5.5 V	± 1.8	°C (max)
		$T_A = 0^\circ\text{C}$ to 70°C	$V_{DD} = 1.9$ to 5.5 V	± 2.0	
		$T_A = 0^\circ\text{C}$ to 90°C	$V_{DD} = 1.9$ to 5.5 V	± 2.1	
		$T_A = 0^\circ\text{C}$ to 120°C	$V_{DD} = 1.9$ to 5.5 V	± 2.2	
		$T_A = 0^\circ\text{C}$ to 150°C	$V_{DD} = 1.9$ to 5.5 V	± 2.3	
		$T_A = -50^\circ\text{C}$ to 0°C	$V_{DD} = 2.3$ to 5.5 V	± 1.7	
	Gain 3: for Trip Point Range 110 - 129°C	$T_A = 20^\circ\text{C}$ to 40°C	$V_{DD} = 2.3$ to 5.5 V	± 1.8	°C (max)
		$T_A = 0^\circ\text{C}$ to 70°C	$V_{DD} = 2.5$ to 5.5 V	± 2.0	
		$T_A = 0^\circ\text{C}$ to 90°C	$V_{DD} = 2.5$ to 5.5 V	± 2.1	
		$T_A = 0^\circ\text{C}$ to 120°C	$V_{DD} = 2.5$ to 5.5 V	± 2.2	
		$T_A = 0^\circ\text{C}$ to 150°C	$V_{DD} = 2.5$ to 5.5 V	± 2.3	
		$T_A = -50^\circ\text{C}$ to 0°C	$V_{DD} = 3.0$ to 5.5 V	± 1.7	
	Gain 4: for Trip Point Range 130 - 150°C	$T_A = 20^\circ\text{C}$ to 40°C	$V_{DD} = 2.7$ to 5.5 V	± 1.8	°C (max)
		$T_A = 0^\circ\text{C}$ to 70°C	$V_{DD} = 3.0$ to 5.5 V	± 2.0	
$T_A = 0^\circ\text{C}$ to 90°C		$V_{DD} = 3.0$ to 5.5 V	± 2.1		
$T_A = 0^\circ\text{C}$ to 120°C		$V_{DD} = 3.0$ to 5.5 V	± 2.2		
$T_A = 0^\circ\text{C}$ to 150°C		$V_{DD} = 3.0$ to 5.5 V	± 2.3		
$T_A = -50^\circ\text{C}$ to 0°C		$V_{DD} = 3.6$ to 5.5 V	± 1.7		

(1) Changes in output due to self heating can be computed by multiplying the internal dissipation by the temperature resistance.

(2) Limits are guaranteed to TI's AOQL (Average Outgoing Quality Level).

(3) Accuracy is defined as the error between the measured and reference output voltages, tabulated in the [Conversion Table](#) at the specified conditions of supply gain setting, voltage, and temperature (expressed in °C). Accuracy limits include line regulation within the specified conditions. Accuracy limits do not include load regulation; they assume no DC load.

Electrical Characteristics

Unless otherwise noted, these specifications apply for $+V_{DD} = +1.6V$ to $+5.5V$. **Boldface limits apply for $T_A = T_J = T_{MIN}$ to T_{MAX}** ; all other limits $T_A = T_J = 25^\circ C$.

Symbol	Parameter	Conditions	Typical ⁽¹⁾	Limits ⁽²⁾	Units (Limit)	
GENERAL SPECIFICATIONS						
I_S	Quiescent Power Supply Current		8	16	μA (max)	
	Hysteresis		5	5.5	$^\circ C$ (max)	
		4.5		$^\circ C$ (min)		
OVERTEMP DIGITAL OUTPUT		ACTIVE HIGH, PUSH-PULL				
V_{OH}	Logic "1" Output Voltage	$V_{DD} \geq 1.6V$	Source $\leq 340 \mu A$		$V_{DD} - 0.2V$	V (min)
		$V_{DD} \geq 2.0V$	Source $\leq 498 \mu A$			
		$V_{DD} \geq 3.3V$	Source $\leq 780 \mu A$			
		$V_{DD} \geq 1.6V$	Source $\leq 600 \mu A$		$V_{DD} - 0.45V$	V (min)
		$V_{DD} \geq 2.0V$	Source $\leq 980 \mu A$			
		$V_{DD} \geq 3.3V$	Source $\leq 1.6 mA$			
BOTH OVERTEMP and $\overline{OVERTEMP}$ DIGITAL OUTPUTS						
V_{OL}	Logic "0" Output Voltage	$V_{DD} \geq 1.6V$	Sink $\leq 385 \mu A$		0.2	V (max)
		$V_{DD} \geq 2.0V$	Sink $\leq 500 \mu A$			
		$V_{DD} \geq 3.3V$	Sink $\leq 730 \mu A$			
		$V_{DD} \geq 1.6V$	Sink $\leq 690 \mu A$		0.45	
		$V_{DD} \geq 2.0V$	Sink $\leq 1.05 mA$			
		$V_{DD} \geq 3.3V$	Sink $\leq 1.62 mA$			
OVERTEMP DIGITAL OUTPUT		ACTIVE LOW, OPEN DRAIN				
I_{OH}	Logic "1" Output Leakage Current ⁽³⁾	$T_A = 30^\circ C$	0.001	1	μA (max)	
		$T_A = 150^\circ C$	0.025			
V_{TEMP} ANALOG TEMPERATURE SENSOR OUTPUT						
	V_{TEMP} Sensor Gain	Gain 1: If Trip Point = 0 - 69 $^\circ C$		-5.1		mV/ $^\circ C$
		Gain 2: If Trip Point = 70 - 109 $^\circ C$		-7.7		mV/ $^\circ C$
		Gain 3: If Trip Point = 110 - 129 $^\circ C$		-10.3		mV/ $^\circ C$
		Gain 4: If Trip Point = 130 - 150 $^\circ C$		-12.8		mV/ $^\circ C$
	V_{TEMP} Load Regulation ⁽⁴⁾	$1.6V \leq V_{DD} < 1.8V$	Source $\leq 90 \mu A$ ($V_{DD} - V_{TEMP}$) $\geq 200 mV$	-0.1	-1	mV (max)
			Sink $\leq 100 \mu A$ $V_{TEMP} \geq 260 mV$	0.1	1	mV (max)
		$V_{DD} \geq 1.8V$	Source $\leq 120 \mu A$ ($V_{DD} - V_{TEMP}$) $\geq 200 mV$	-0.1	-1	mV (max)
			Sink $\leq 200 \mu A$ $V_{TEMP} \geq 260 mV$	0.1	1	mV (max)
		Source or Sink = 100 μA		1		Ω
	V_{DD} Supply- to- V_{TEMP} DC Line Regulation ⁽⁵⁾	$V_{DD} = +1.6V$ to $+5.5V$	0.29		mV	
			74		$\mu V/V$	
			-82		dB	
C_L	V_{TEMP} Output Load Capacitance	Without series resistor. See CAPACITIVE LOADS	1100		pF (max)	

(1) Typicals are at $T_J = T_A = 25^\circ C$ and represent most likely parametric norm.

(2) Limits are guaranteed to TI's AOQL (Average Outgoing Quality Level).

(3) The $1\mu A$ limit is based on a testing limitation and does not reflect the actual performance of the part. Expect to see a doubling of the current for every $15^\circ C$ increase in temperature. For example, the $1nA$ typical current at $25^\circ C$ would increase to $16nA$ at $85^\circ C$.

(4) Source currents are flowing out of the LM26LV/LM26LV-Q1. Sink currents are flowing into the LM26LV/LM26LV-Q1.

(5) Line regulation (DC) is calculated by subtracting the output voltage at the highest supply voltage from the output voltage at the lowest supply voltage. The typical DC line regulation specification does not include the output voltage shift discussed in Section 4.3.

Electrical Characteristics (continued)

Unless otherwise noted, these specifications apply for $+V_{DD} = +1.6V$ to $+5.5V$. **Boldface limits apply for $T_A = T_J = T_{MIN}$ to T_{MAX}** ; all other limits $T_A = T_J = 25^\circ C$.

Symbol	Parameter	Conditions	Typical ⁽¹⁾	Limits ⁽²⁾	Units (Limit)
TRIP TEST DIGITAL INPUT					
V_{IH}	Logic "1" Threshold Voltage			$V_{DD} - 0.5$	V (min)
V_{IL}	Logic "0" Threshold Voltage			0.5	V (max)
I_{IH}	Logic "1" Input Current		1.5	2.5	μA (max)
I_{IL}	Logic "0" Input Current ⁽⁶⁾		0.001	1	μA (max)
TIMING					
t_{EN}	Time from Power On to Digital Output Enabled. See definition below.		1.1	2.3	ms (max)
t_V	Time from Power On to Analog Temperature Valid. See definition below.	$V_{TEMP} C_L = 0 \text{ pF to } 1100 \text{ pF}$	1.0	2.9	ms (max)

(6) The $1\mu A$ limit is based on a testing limitation and does not reflect the actual performance of the part. Expect to see a doubling of the current for every $15^\circ C$ increase in temperature. For example, the $1nA$ typical current at $25^\circ C$ would increase to $16nA$ at $85^\circ C$.

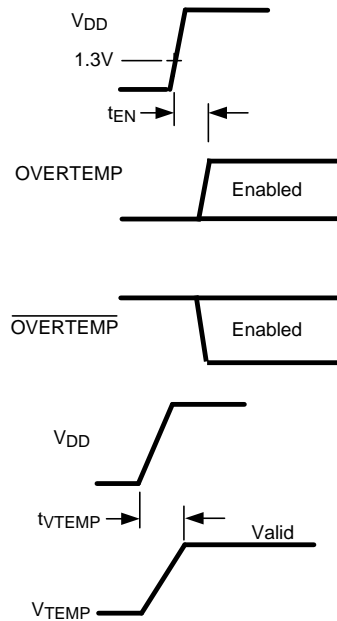

Figure 3. Definitions of t_{EN} and t_V

Typical Performance Characteristics

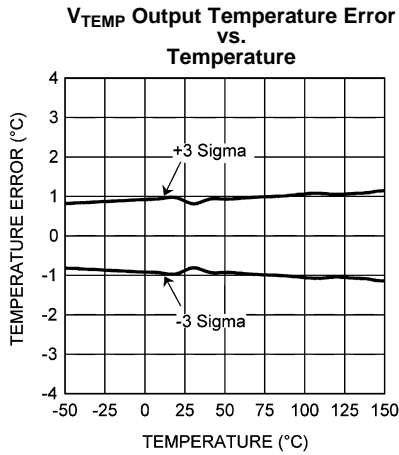

Figure 4.

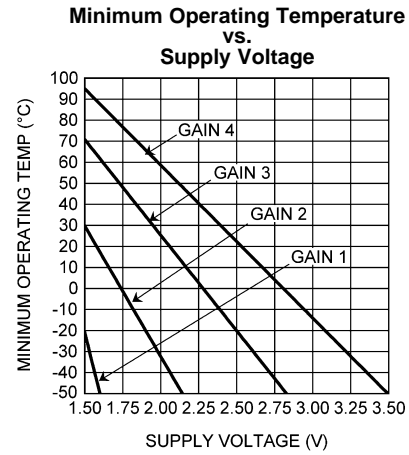

Figure 5.

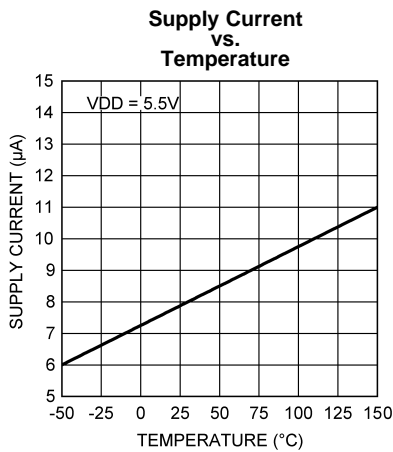

Figure 6.

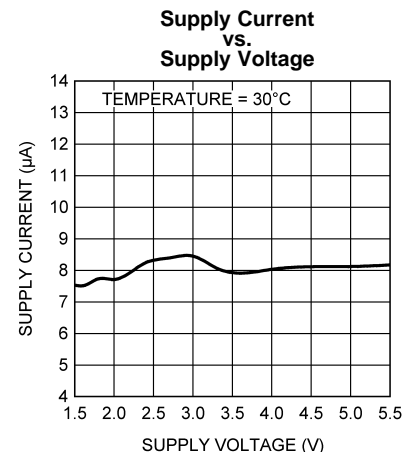

Figure 7.

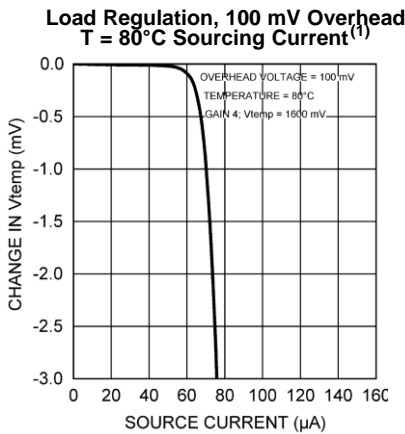

Figure 8.

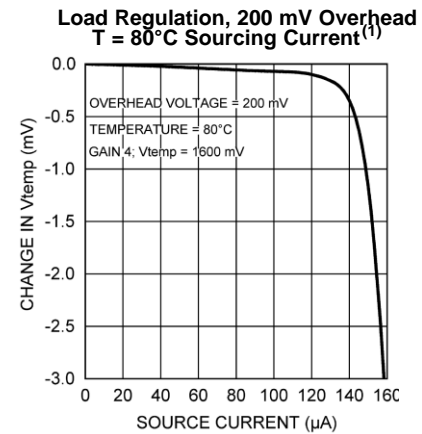

Figure 9.

(1) The curves shown represent typical performance under worst-case conditions. Performance improves with larger overhead ($V_{DD} - V_{TEMP}$), larger V_{DD} , and lower temperatures.

Typical Performance Characteristics (continued)

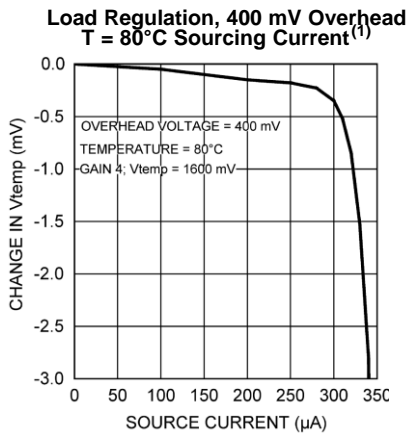

Figure 10.

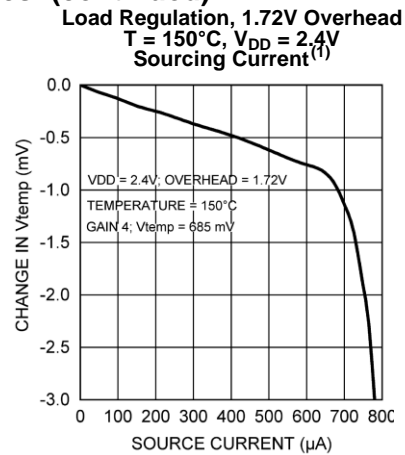

Figure 11.

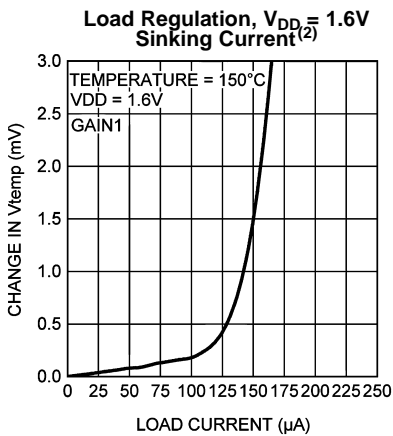

Figure 12.

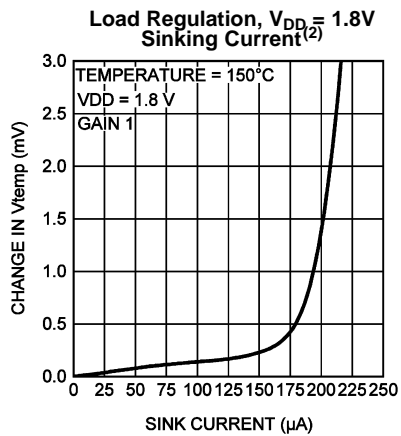

Figure 13.

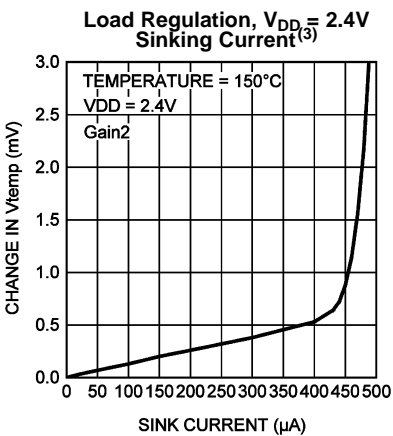

Figure 14.

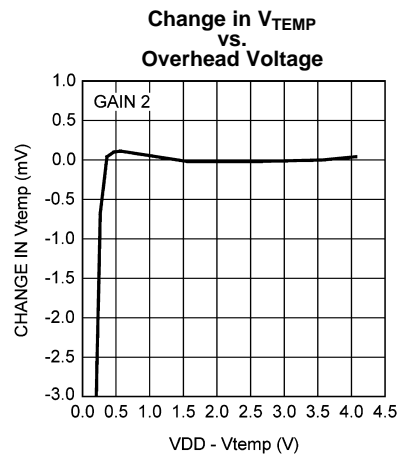

Figure 15.

- (2) The curves shown represent typical performance under worst-case conditions. Performance improves with larger V_{TEMP}, larger V_{DD} and lower temperatures.
- (3) The curves shown represent typical performance under worst-case conditions. Performance improves with larger V_{TEMP}, larger V_{DD} and lower temperatures.

Typical Performance Characteristics (continued)

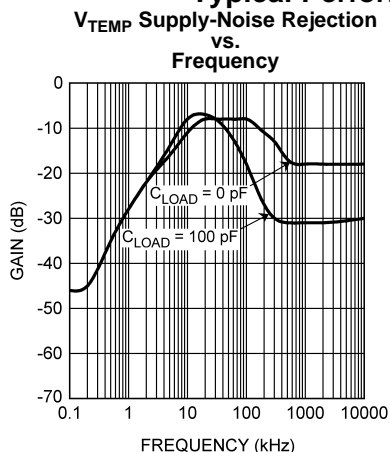

Figure 16.

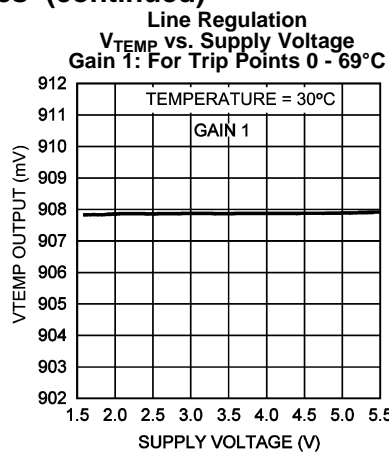

Figure 17.

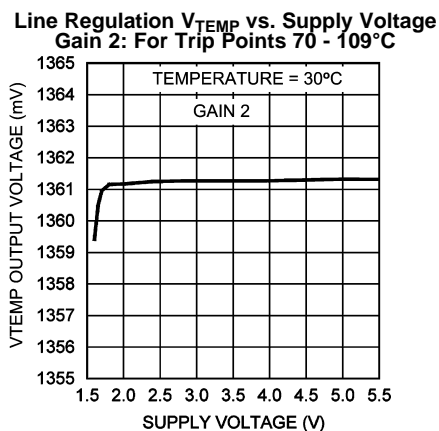

Figure 18.

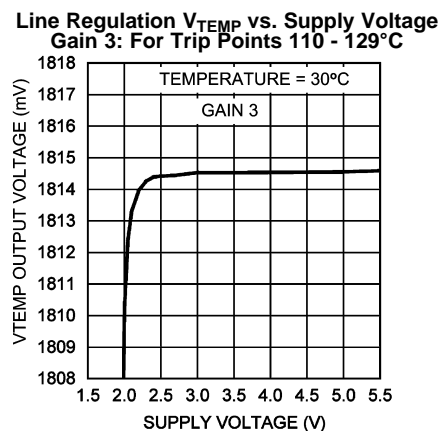

Figure 19.

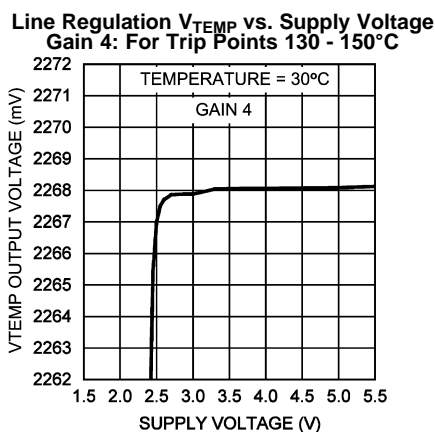

Figure 20.

LM26LV/LM26LV-Q1 V_{TEMP} VS DIE TEMPERATURE CONVERSION TABLE

The LM26LV/LM26LV-Q1 has one out of four possible factory-set gains, Gain 1 through Gain 4, depending on the range of the Temperature Trip Point. The V_{TEMP} temperature sensor voltage, in millivolts, at each discrete die temperature over the complete operating temperature range, and for each of the four Temperature Trip Point ranges, is shown in the [Conversion Table](#). This table is the reference from which the LM26LV/LM26LV-Q1 accuracy specifications (listed in the [Electrical Characteristics](#) section) are determined. This table can be used, for example, in a host processor look-up table. See [The Second-Order Equation \(Parabolic\)](#) for the parabolic equation used in the Conversion Table.

Table 1. V_{TEMP} Temperature Sensor Output Voltage vs Die Temperature Conversion Table⁽¹⁾

Die Temp., °C	V_{TEMP} , Analog Output Voltage, mV			
	Gain 1: for $T_{TRIP} = 0-69^{\circ}\text{C}$	Gain 2: for $T_{TRIP} = 70-109^{\circ}\text{C}$	Gain 3: for $T_{TRIP} = 110-129^{\circ}\text{C}$	Gain 4: for $T_{TRIP} = 130-150^{\circ}\text{C}$
-50	1312	1967	2623	3278
-49	1307	1960	2613	3266
-48	1302	1952	2603	3253
-47	1297	1945	2593	3241
-46	1292	1937	2583	3229
-45	1287	1930	2573	3216
-44	1282	1922	2563	3204
-43	1277	1915	2553	3191
-42	1272	1908	2543	3179
-41	1267	1900	2533	3166
-40	1262	1893	2523	3154
-39	1257	1885	2513	3141
-38	1252	1878	2503	3129
-37	1247	1870	2493	3116
-36	1242	1863	2483	3104
-35	1237	1855	2473	3091
-34	1232	1848	2463	3079
-33	1227	1840	2453	3066
-32	1222	1833	2443	3054
-31	1217	1825	2433	3041
-30	1212	1818	2423	3029
-29	1207	1810	2413	3016
-28	1202	1803	2403	3004
-27	1197	1795	2393	2991
-26	1192	1788	2383	2979
-25	1187	1780	2373	2966
-24	1182	1773	2363	2954
-23	1177	1765	2353	2941
-22	1172	1757	2343	2929
-21	1167	1750	2333	2916
-20	1162	1742	2323	2903
-19	1157	1735	2313	2891
-18	1152	1727	2303	2878
-17	1147	1720	2293	2866

(1) The V_{TEMP} temperature sensor output voltage, in mV, vs Die Temperature, in °C, for each of the four gains corresponding to each of the four Temperature Trip Point Ranges. Gain 1 is the sensor gain used for Temperature Trip Point 0 - 69°C. Likewise Gain 2 is for Trip Points 70 - 109°C; Gain 3 for 110 - 129°C; and Gain 4 for 130 - 150°C. $V_{DD} = 5.0\text{V}$. The values in **bold** font are for the Trip Point range.

Table 1. V_{TEMP} Temperature Sensor Output Voltage vs Die Temperature Conversion Table⁽¹⁾ (continued)

Die Temp., °C	V_{TEMP} , Analog Output Voltage, mV			
	Gain 1: for $T_{TRIP} = 0-69^{\circ}\text{C}$	Gain 2: for $T_{TRIP} = 70-109^{\circ}\text{C}$	Gain 3: for $T_{TRIP} = 110-129^{\circ}\text{C}$	Gain 4: for $T_{TRIP} = 130-150^{\circ}\text{C}$
-16	1142	1712	2283	2853
-15	1137	1705	2272	2841
-14	1132	1697	2262	2828
-13	1127	1690	2252	2815
-12	1122	1682	2242	2803
-11	1116	1674	2232	2790
-10	1111	1667	2222	2777
-9	1106	1659	2212	2765
-8	1101	1652	2202	2752
-7	1096	1644	2192	2740
-6	1091	1637	2182	2727
-5	1086	1629	2171	2714
-4	1081	1621	2161	2702
-3	1076	1614	2151	2689
-2	1071	1606	2141	2676
-1	1066	1599	2131	2664
0	1061	1591	2121	2651
1	1056	1583	2111	2638
2	1051	1576	2101	2626
3	1046	1568	2090	2613
4	1041	1561	2080	2600
5	1035	1553	2070	2587
6	1030	1545	2060	2575
7	1025	1538	2050	2562
8	1020	1530	2040	2549
9	1015	1522	2029	2537
10	1010	1515	2019	2524
11	1005	1507	2009	2511
12	1000	1499	1999	2498
13	995	1492	1989	2486
14	990	1484	1978	2473
15	985	1477	1968	2460
16	980	1469	1958	2447
17	974	1461	1948	2435
18	969	1454	1938	2422
19	964	1446	1927	2409
20	959	1438	1917	2396
21	954	1431	1907	2383
22	949	1423	1897	2371
23	944	1415	1886	2358
24	939	1407	1876	2345
25	934	1400	1866	2332
26	928	1392	1856	2319
27	923	1384	1845	2307
28	918	1377	1835	2294
29	913	1369	1825	2281

Table 1. V_{TEMP} Temperature Sensor Output Voltage vs Die Temperature Conversion Table⁽¹⁾ (continued)

Die Temp., °C	V_{TEMP} , Analog Output Voltage, mV			
	Gain 1: for $T_{TRIP} = 0-69^{\circ}\text{C}$	Gain 2: for $T_{TRIP} = 70-109^{\circ}\text{C}$	Gain 3: for $T_{TRIP} = 110-129^{\circ}\text{C}$	Gain 4: for $T_{TRIP} = 130-150^{\circ}\text{C}$
30	908	1361	1815	2268
31	903	1354	1804	2255
32	898	1346	1794	2242
33	892	1338	1784	2230
34	887	1331	1774	2217
35	882	1323	1763	2204
36	877	1315	1753	2191
37	872	1307	1743	2178
38	867	1300	1732	2165
39	862	1292	1722	2152
40	856	1284	1712	2139
41	851	1276	1701	2127
42	846	1269	1691	2114
43	841	1261	1681	2101
44	836	1253	1670	2088
45	831	1245	1660	2075
46	825	1238	1650	2062
47	820	1230	1639	2049
48	815	1222	1629	2036
49	810	1214	1619	2023
50	805	1207	1608	2010
51	800	1199	1598	1997
52	794	1191	1588	1984
53	789	1183	1577	1971
54	784	1176	1567	1958
55	779	1168	1557	1946
56	774	1160	1546	1933
57	769	1152	1536	1920
58	763	1144	1525	1907
59	758	1137	1515	1894
60	753	1129	1505	1881
61	748	1121	1494	1868
62	743	1113	1484	1855
63	737	1105	1473	1842
64	732	1098	1463	1829
65	727	1090	1453	1816
66	722	1082	1442	1803
67	717	1074	1432	1790
68	711	1066	1421	1776
69	706	1059	1411	1763
70	701	1051	1400	1750
71	696	1043	1390	1737
72	690	1035	1380	1724
73	685	1027	1369	1711
74	680	1019	1359	1698
75	675	1012	1348	1685

Table 1. V_{TEMP} Temperature Sensor Output Voltage vs Die Temperature Conversion Table⁽¹⁾ (continued)

Die Temp., °C	V_{TEMP} , Analog Output Voltage, mV			
	Gain 1: for $T_{TRIP} = 0-69^{\circ}\text{C}$	Gain 2: for $T_{TRIP} = 70-109^{\circ}\text{C}$	Gain 3: for $T_{TRIP} = 110-129^{\circ}\text{C}$	Gain 4: for $T_{TRIP} = 130-150^{\circ}\text{C}$
76	670	1004	1338	1672
77	664	996	1327	1659
78	659	988	1317	1646
79	654	980	1306	1633
80	649	972	1296	1620
81	643	964	1285	1607
82	638	957	1275	1593
83	633	949	1264	1580
84	628	941	1254	1567
85	622	933	1243	1554
86	617	925	1233	1541
87	612	917	1222	1528
88	607	909	1212	1515
89	601	901	1201	1501
90	596	894	1191	1488
91	591	886	1180	1475
92	586	878	1170	1462
93	580	870	1159	1449
94	575	862	1149	1436
95	570	854	1138	1422
96	564	846	1128	1409
97	559	838	1117	1396
98	554	830	1106	1383
99	549	822	1096	1370
100	543	814	1085	1357
101	538	807	1075	1343
102	533	799	1064	1330
103	527	791	1054	1317
104	522	783	1043	1304
105	517	775	1032	1290
106	512	767	1022	1277
107	506	759	1011	1264
108	501	751	1001	1251
109	496	743	990	1237
110	490	735	979	1224
111	485	727	969	1211
112	480	719	958	1198
113	474	711	948	1184
114	469	703	937	1171
115	464	695	926	1158
116	459	687	916	1145
117	453	679	905	1131
118	448	671	894	1118
119	443	663	884	1105
120	437	655	873	1091
121	432	647	862	1078

Table 1. V_{TEMP} Temperature Sensor Output Voltage vs Die Temperature Conversion Table⁽¹⁾ (continued)

Die Temp., °C	V _{TEMP} , Analog Output Voltage, mV			
	Gain 1: for T _{TRIP} = 0-69°C	Gain 2: for T _{TRIP} = 70-109°C	Gain 3: for T _{TRIP} = 110-129°C	Gain 4: for T _{TRIP} = 130-150°C
122	427	639	852	1065
123	421	631	841	1051
124	416	623	831	1038
125	411	615	820	1025
126	405	607	809	1011
127	400	599	798	998
128	395	591	788	985
129	389	583	777	971
130	384	575	766	958
131	379	567	756	945
132	373	559	745	931
133	368	551	734	918
134	362	543	724	904
135	357	535	713	891
136	352	527	702	878
137	346	519	691	864
138	341	511	681	851
139	336	503	670	837
140	330	495	659	824
141	325	487	649	811
142	320	479	638	797
143	314	471	627	784
144	309	463	616	770
145	303	455	606	757
146	298	447	595	743
147	293	438	584	730
148	287	430	573	716
149	282	422	562	703
150	277	414	552	690

V_{TEMP} vs DIE TEMPERATURE APPROXIMATIONS

The LM26LV/LM26LV-Q1's V_{TEMP} analog temperature output is very linear. The [Conversion Table](#) above and the equation in the Section [The Second-Order Equation \(Parabolic\)](#) represent the most accurate typical performance of the V_{TEMP} voltage output vs Temperature.

The Second-Order Equation (Parabolic)

The data from the [Conversion Table](#), or the equation below, when plotted, has an umbrella-shaped parabolic curve. V_{TEMP} is in mV.

$$\begin{aligned}
 \text{GAIN1: } V_{\text{TEMP}} &= 907.9 - 5.132 \times (T_{\text{DIE}} - 30^\circ\text{C}) - 1.08\text{e-}3 \times (T_{\text{DIE}} - 30^\circ\text{C})^2 \\
 \text{GAIN2: } V_{\text{TEMP}} &= 1361.4 - 7.701 \times (T_{\text{DIE}} - 30^\circ\text{C}) - 1.60\text{e-}3 \times (T_{\text{DIE}} - 30^\circ\text{C})^2 \\
 \text{GAIN3: } V_{\text{TEMP}} &= 1814.6 - 10.270 \times (T_{\text{DIE}} - 30^\circ\text{C}) - 2.12\text{e-}3 \times (T_{\text{DIE}} - 30^\circ\text{C})^2 \\
 \text{GAIN4: } V_{\text{TEMP}} &= 2268.1 - 12.838 \times (T_{\text{DIE}} - 30^\circ\text{C}) - 2.64\text{e-}3 \times (T_{\text{DIE}} - 30^\circ\text{C})^2
 \end{aligned}
 \tag{1}$$

The First-Order Approximation (Linear)

For a quicker approximation, although less accurate than the second-order, over the full operating temperature range the linear formula below can be used. Using this formula, with the constant and slope in the following set of equations, the best-fit V_{TEMP} vs Die Temperature performance can be calculated with an approximation error less than 18 mV. V_{TEMP} is in mV.

$$\text{GAIN1: } V_{TEMP} = 1060 - 5.18 \times T_{DIE}$$

$$\text{GAIN2: } V_{TEMP} = 1590 - 7.77 \times T_{DIE}$$

$$\text{GAIN3: } V_{TEMP} = 2119 - 10.36 \times T_{DIE}$$

$$\text{GAIN4: } V_{TEMP} = 2649 - 12.94 \times T_{DIE}$$

(2)

First-Order Approximation (Linear) over Small Temperature Range

For a linear approximation, a line can easily be calculated over the desired temperature range from the [Conversion Table](#) using the two-point equation:

$$V - V_1 = \left(\frac{V_2 - V_1}{T_2 - T_1} \right) \times (T - T_1) \quad (3)$$

Where V is in mV, T is in °C, T_1 and V_1 are the coordinates of the lowest temperature, T_2 and V_2 are the coordinates of the highest temperature.

For example, if we want to determine the equation of a line with Gain 4, over a temperature range of 20°C to 50°C, we would proceed as follows:

$$V - 2396 \text{ mV} = \left(\frac{2010 \text{ mV} - 2396 \text{ mV}}{50^\circ\text{C} - 20^\circ\text{C}} \right) \times (T - 20^\circ\text{C}) \quad (4)$$

$$V - 2396 \text{ mV} = (-12.8 \text{ mV}/^\circ\text{C}) \times (T - 20^\circ\text{C}) \quad (5)$$

$$V = (-12.8 \text{ mV}/^\circ\text{C}) \times (T - 20^\circ\text{C}) + 2396 \text{ mV} \quad (6)$$

Using this method of linear approximation, the transfer function can be approximated for one or more temperature ranges of interest.

OVERTEMP and $\overline{\text{OVERTEMP}}$ Digital Outputs

The OVERTEMP Active High, Push-Pull Output and the $\overline{\text{OVERTEMP}}$ Active Low, Open-Drain Output both assert at the same time whenever the Die Temperature reaches the factory preset Temperature Trip Point. They also assert simultaneously whenever the TRIP TEST pin is set high. Both outputs de-assert when the die temperature goes below the Temperature Trip Point - Hysteresis. These two types of digital outputs enable the user the flexibility to choose the type of output that is most suitable for his design.

Either the OVERTEMP or the $\overline{\text{OVERTEMP}}$ Digital Output pins can be left open if not used.

$\overline{\text{OVERTEMP}}$ OPEN-DRAIN DIGITAL OUTPUT

The $\overline{\text{OVERTEMP}}$ Active Low, Open-Drain Digital Output, if used, requires a pull-up resistor between this pin and V_{DD} . The following section shows how to determine the pull-up resistor value.

Determining the Pull-up Resistor Value

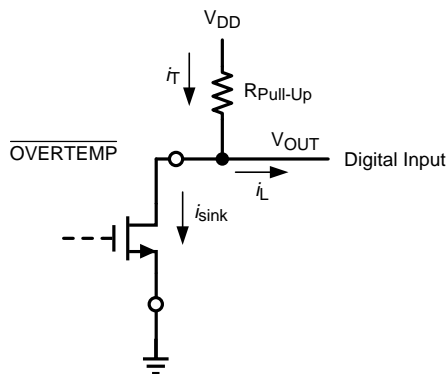

The Pull-up resistor value is calculated at the condition of maximum total current, i_T , through the resistor. The total current is:

$$i_T = i_L + i_{\text{sink}} \quad (7)$$

where,

i_T i_T is the maximum total current through the Pull-up Resistor at V_{OL} .

i_L i_L is the load current, which is very low for typical digital inputs.

V_{OUT} V_{OUT} is the Voltage at the $\overline{\text{OVERTEMP}}$ pin. Use V_{OL} for calculating the Pull-up resistor.

$V_{\text{DD(Max)}}$ $V_{\text{DD(Max)}}$ is the maximum power supply voltage to be used in the customer's system.

The pull-up resistor maximum value can be found by using the following formula:

$$R_{\text{pull-up}} = \frac{V_{\text{DD(Max)}} - V_{OL}}{i_T} \quad (8)$$

EXAMPLE CALCULATION

Suppose we have, for our example, a V_{DD} of $3.3 \text{ V} \pm 0.3\text{V}$, a CMOS digital input as a load, a V_{OL} of 0.2 V.

1. We see that for V_{OL} of 0.2 V the electrical specification for $\overline{\text{OVERTEMP}}$ shows a maximum i_{sink} of 385 μA .
2. Let $i_L = 1 \mu\text{A}$, then i_T is about 386 μA max. If we select 35 μA as the current limit then i_T for the calculation becomes 35 μA
3. We notice that $V_{\text{DD(Max)}}$ is $3.3\text{V} + 0.3\text{V} = 3.6\text{V}$ and then calculate the pull-up resistor as $R_{\text{Pull-up}} = (3.6 - 0.2)/35 \mu\text{A} = 97\text{k}$
4. Based on this calculated value, we select the closest resistor value in the tolerance family we are using.

In our example, if we are using 5% resistor values, then the next closest value is 100 k Ω .

NOISE IMMUNITY

The LM26LV/LM26LV-Q1 is virtually immune from false triggers on the **OVERTEMP** and **OVERTEMP** digital outputs due to noise on the power supply. Test have been conducted showing that, with the die temperature within 0.5°C of the temperature trip point, and the severe test of a 3 V_{pp} square wave "noise" signal injected on the V_{DD} line, over the V_{DD} range of 2V to 5V, there were no false triggers.

TRIP TEST Digital Input

The TRIP TEST pin simply provides a means to test the **OVERTEMP** and **OVERTEMP** digital outputs electronically by causing them to assert, at any operating temperature, as a result of forcing the TRIP TEST pin high.

When the TRIP TEST pin is pulled high the V_{TEMP} pin will be at the V_{TRIP} voltage.

If not used, the TRIP TEST pin may either be left open or grounded.

V_{TEMP} Analog Temperature Sensor Output

The V_{TEMP} push-pull output provides the ability to sink and source significant current. This is beneficial when, for example, driving dynamic loads like an input stage on an analog-to-digital converter (ADC). In these applications the source current is required to quickly charge the input capacitor of the ADC. See the [Applications Circuits](#) section for more discussion of this topic. The LM26LV/LM26LV-Q1 is ideal for this and other applications which require strong source or sink current.

NOISE CONSIDERATIONS

The LM26LV/LM26LV-Q1's supply-noise rejection (the ratio of the AC signal on V_{TEMP} to the AC signal on V_{DD}) was measured during bench tests. It's typical attenuation is shown in the [Typical Performance Characteristics](#) section. A load capacitor on the output can help to filter noise.

For operation in very noisy environments, some bypass capacitance should be present on the supply within approximately 2 inches of the LM26LV/LM26LV-Q1.

CAPACITIVE LOADS

The V_{TEMP} Output handles capacitive loading well. In an extremely noisy environment, or when driving a switched sampling input on an ADC, it may be necessary to add some filtering to minimize noise coupling. Without any precautions, the V_{TEMP} can drive a capacitive load less than or equal to 1100 pF as shown in [Figure 21](#). For capacitive loads greater than 1100 pF, a series resistor is required on the output, as shown in [Figure 22](#), to maintain stable conditions.

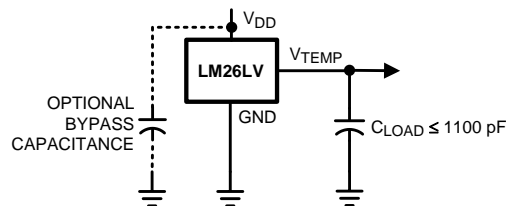

Figure 21. LM26LV/LM26LV-Q1 No Decoupling Required for Capacitive Loads Less than 1100pF.

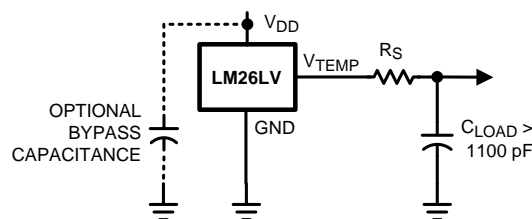

Figure 22. LM26LV/LM26LV-Q1 with series resistor for capacitive loading greater than 1100pF

C_{LOAD}	Minimum R_S
1.1 nF to 99 nF	3 k Ω
100 nF to 999 nF	1.5 k Ω
1 μ F	800 Ω

VOLTAGE SHIFT

The LM26LV/LM26LV-Q1 is very linear over temperature and supply voltage range. Due to the intrinsic behavior of an NMOS/PMOS rail-to-rail buffer, a slight shift in the output can occur when the supply voltage is ramped over the operating range of the device. The location of the shift is determined by the relative levels of V_{DD} and V_{TEMP} . The shift typically occurs when $V_{DD} - V_{TEMP} = 1.0V$.

This slight shift (a few millivolts) takes place over a wide change (approximately 200 mV) in V_{DD} or V_{TEMP} . Since the shift takes place over a wide temperature change of 5°C to 20°C, V_{TEMP} is always monotonic. The accuracy specifications in the [Electrical Characteristics](#) table already includes this possible shift.

Mounting and Temperature Conductivity

The LM26LV/LM26LV-Q1 can be applied easily in the same way as other integrated-circuit temperature sensors. It can be glued or cemented to a surface.

The best thermal conductivity between the device and the PCB is achieved by soldering the DAP of the package to the thermal pad on the PCB. The temperatures of the lands and traces to the other leads of the LM26LV/LM26LV-Q1 will also affect the temperature reading.

Alternatively, the LM26LV/LM26LV-Q1 can be mounted inside a sealed-end metal tube, and can then be dipped into a bath or screwed into a threaded hole in a tank. As with any IC, the LM26LV/LM26LV-Q1 and accompanying wiring and circuits must be kept insulated and dry, to avoid leakage and corrosion. This is especially true if the circuit may operate at cold temperatures where condensation can occur. If moisture creates a short circuit from the V_{TEMP} output to ground or V_{DD} , the V_{TEMP} output from the LM26LV/LM26LV-Q1 will not be correct. Printed-circuit coatings are often used to ensure that moisture cannot corrode the leads or circuit traces.

The thermal resistance junction-to-ambient (θ_{JA}) is the parameter used to calculate the rise of a device junction temperature due to its power dissipation. The equation used to calculate the rise in the LM26LV/LM26LV-Q1's die temperature is

$$T_J = T_A + \theta_{JA} \left[(V_{DD}I_Q) + (V_{DD} - V_{TEMP}) I_L \right] \quad (9)$$

where T_A is the ambient temperature, I_Q is the quiescent current, I_L is the load current on the output, and V_O is the output voltage. For example, in an application where $T_A = 30^\circ\text{C}$, $V_{DD} = 5\text{ V}$, $I_{DD} = 9\ \mu\text{A}$, Gain 4, $V_{TEMP} = 2231\text{ mV}$, and $I_L = 2\ \mu\text{A}$, the junction temperature would be 30.021°C , showing a self-heating error of only 0.021°C . Since the LM26LV/LM26LV-Q1's junction temperature is the actual temperature being measured, care should be taken to minimize the load current that the V_{TEMP} output is required to drive. If the OVERTEMP output is used with a 100 k pull-up resistor, and this output is asserted (low), then for this example the additional contribution is $[(152^\circ\text{C/W}) \times (5\text{V})^2 / 100\text{k}] = 0.038^\circ\text{C}$ for a total self-heating error of 0.059°C . [Table 2](#) shows the thermal resistance of the LM26LV/LM26LV-Q1.

Table 2. LM26LV/LM26LV-Q1 Thermal Resistance

Device Number	NS Package Number	Thermal Resistance (θ_{JA})
LM26LVCSID/LM26LVQCISD	NGF0006A	152° C/W

Applications Circuits

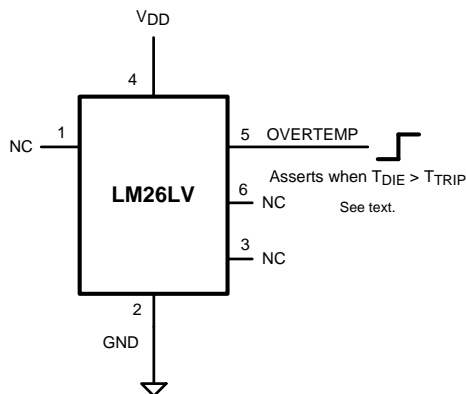

Figure 23. Temperature Switch Using Push-Pull Output

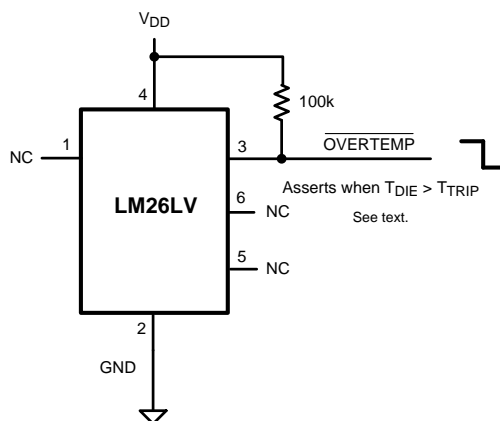

Figure 24. Temperature Switch Using Open-Drain Output

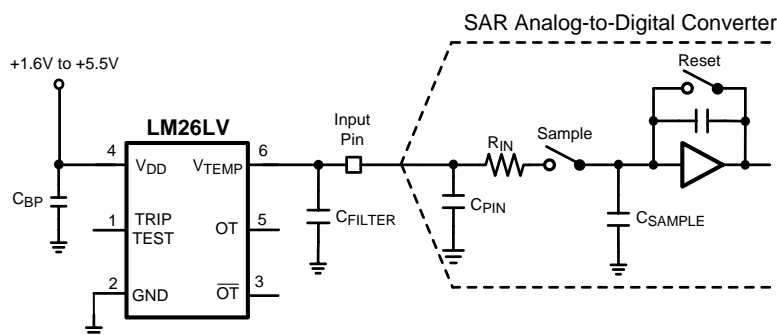

Figure 25. Suggested Connection to a Sampling Analog-to-Digital Converter Input Stage

Most CMOS ADCs found in microcontrollers and ASICs have a sampled data comparator input structure. When the ADC charges the sampling cap, it requires instantaneous charge from the output of the analog source such as the LM26LV/LM26LV-Q1 temperature sensor and many op amps. This requirement is easily accommodated by the addition of a capacitor (C_{FILTER}). The size of C_{FILTER} depends on the size of the sampling capacitor and the sampling frequency. Since not all ADCs have identical input stages, the charge requirements will vary. This general ADC application is shown as an example only.

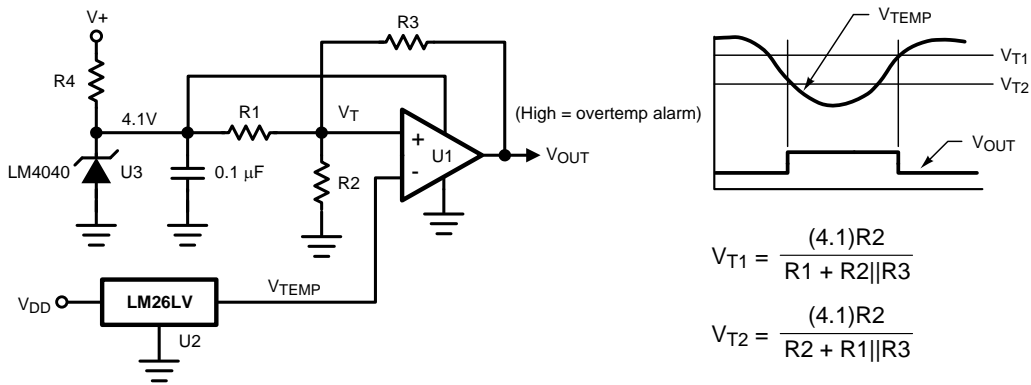

Figure 26. Celsius Temperature Switch

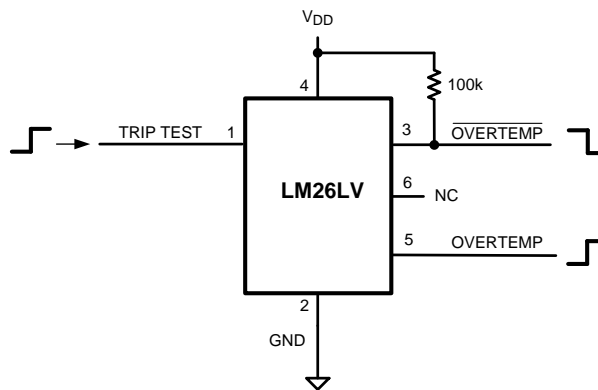

Figure 27. TRIP TEST Digital Output Test Circuit

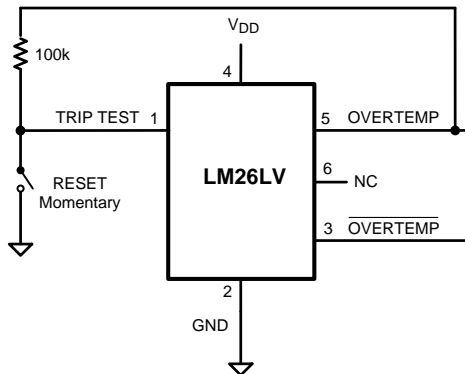

Figure 28. Latch Circuit using OVERTEMP Output

The TRIP TEST pin, normally used to check the operation of the OVERTEMP and $\overline{\text{OVERTEMP}}$ pins, may be used to latch the outputs whenever the temperature exceeds the programmed limit and causes the digital outputs to assert. As shown in Figure 28, when $\overline{\text{OVERTEMP}}$ goes high the TRIP TEST input is also pulled high and causes OVERTEMP output to latch high and the OVERTEMP output to latch low. The latch can be released by either momentarily pulling the TRIP TEST pin low (GND), or by toggling the power supply to the device. The resistor limits the current out of the OVERTEMP output pin.

REVISION HISTORY

Changes from Revision E (February 2013) to Revision F	Page
<hr/> <ul style="list-style-type: none">• Changed layout of National Data Sheet to TI format	22

PACKAGING INFORMATION

Orderable Device	Status (1)	Package Type	Package Drawing	Pins	Package Qty	Eco Plan (2)	Lead/Ball Finish	MSL Peak Temp (3)	Op Temp (°C)	Device Marking (4/5)	Samples
LM26LVCISD-050/NOPB	ACTIVE	WSO	NGF	6	1000	Green (RoHS & no Sb/Br)	CU SN	Level-1-260C-UNLIM	0 to 150	050	Samples
LM26LVCISD-060/NOPB	ACTIVE	WSO	NGF	6	1000	Green (RoHS & no Sb/Br)	CU SN	Level-1-260C-UNLIM	0 to 150	060	Samples
LM26LVCISD-065/NOPB	ACTIVE	WSO	NGF	6	1000	Green (RoHS & no Sb/Br)	CU SN	Level-1-260C-UNLIM	0 to 150	065	Samples
LM26LVCISD-070/NOPB	ACTIVE	WSO	NGF	6	1000	Green (RoHS & no Sb/Br)	CU SN	Level-1-260C-UNLIM	0 to 150	070	Samples
LM26LVCISD-075/NOPB	ACTIVE	WSO	NGF	6	1000	Green (RoHS & no Sb/Br)	CU SN	Level-1-260C-UNLIM	0 to 150	075	Samples
LM26LVCISD-080/NOPB	ACTIVE	WSO	NGF	6	1000	Green (RoHS & no Sb/Br)	CU SN	Level-1-260C-UNLIM	0 to 150	080	Samples
LM26LVCISD-085/NOPB	ACTIVE	WSO	NGF	6	1000	Green (RoHS & no Sb/Br)	CU SN	Level-1-260C-UNLIM	0 to 150	085	Samples
LM26LVCISD-090/NOPB	ACTIVE	WSO	NGF	6	1000	Green (RoHS & no Sb/Br)	CU SN	Level-1-260C-UNLIM	0 to 150	090	Samples
LM26LVCISD-095/NOPB	ACTIVE	WSO	NGF	6	1000	Green (RoHS & no Sb/Br)	CU SN	Level-1-260C-UNLIM	0 to 150	095	Samples
LM26LVCISD-100/NOPB	ACTIVE	WSO	NGF	6	1000	Green (RoHS & no Sb/Br)	CU SN	Level-1-260C-UNLIM	0 to 150	100	Samples
LM26LVCISD-105/NOPB	ACTIVE	WSO	NGF	6	1000	Green (RoHS & no Sb/Br)	CU SN	Level-1-260C-UNLIM	0 to 150	105	Samples
LM26LVCISD-110/NOPB	ACTIVE	WSO	NGF	6	1000	Green (RoHS & no Sb/Br)	CU SN	Level-1-260C-UNLIM	0 to 150	110	Samples
LM26LVCISD-115/NOPB	ACTIVE	WSO	NGF	6	1000	Green (RoHS & no Sb/Br)	CU SN	Level-1-260C-UNLIM	0 to 150	115	Samples
LM26LVCISD-120/NOPB	ACTIVE	WSO	NGF	6	1000	Green (RoHS & no Sb/Br)	CU SN	Level-1-260C-UNLIM	0 to 150	120	Samples
LM26LVCISD-125/NOPB	ACTIVE	WSO	NGF	6	1000	Green (RoHS & no Sb/Br)	CU SN	Level-1-260C-UNLIM	0 to 150	125	Samples
LM26LVCISD-130/NOPB	ACTIVE	WSO	NGF	6	1000	Green (RoHS & no Sb/Br)	CU SN	Level-1-260C-UNLIM	0 to 150	130	Samples
LM26LVCISD-135/NOPB	ACTIVE	WSO	NGF	6	1000	Green (RoHS & no Sb/Br)	CU SN	Level-1-260C-UNLIM	0 to 150	135	Samples

Orderable Device	Status (1)	Package Type	Package Drawing	Pins	Package Qty	Eco Plan (2)	Lead/Ball Finish	MSL Peak Temp (3)	Op Temp (°C)	Device Marking (4/5)	Samples
LM26LVCISD-140/NOPB	ACTIVE	WSO	NGF	6	1000	Green (RoHS & no Sb/Br)	CU SN	Level-1-260C-UNLIM	0 to 150	140	Samples
LM26LVCISD-145/NOPB	ACTIVE	WSO	NGF	6	1000	Green (RoHS & no Sb/Br)	CU SN	Level-1-260C-UNLIM	0 to 150	145	Samples
LM26LVCISD-150/NOPB	ACTIVE	WSO	NGF	6	1000	Green (RoHS & no Sb/Br)	CU SN	Level-1-260C-UNLIM	0 to 150	150	Samples
LM26LVCISDX-050/NOPB	ACTIVE	WSO	NGF	6	4500	Green (RoHS & no Sb/Br)	CU SN	Level-1-260C-UNLIM	0 to 150	050	Samples
LM26LVCISDX-060/NOPB	ACTIVE	WSO	NGF	6	4500	Green (RoHS & no Sb/Br)	CU SN	Level-1-260C-UNLIM	0 to 150	060	Samples
LM26LVCISDX-065/NOPB	ACTIVE	WSO	NGF	6	4500	Green (RoHS & no Sb/Br)	CU SN	Level-1-260C-UNLIM	0 to 150	065	Samples
LM26LVCISDX-070/NOPB	ACTIVE	WSO	NGF	6	4500	Green (RoHS & no Sb/Br)	CU SN	Level-1-260C-UNLIM	0 to 150	070	Samples
LM26LVCISDX-075/NOPB	ACTIVE	WSO	NGF	6	4500	Green (RoHS & no Sb/Br)	CU SN	Level-1-260C-UNLIM	0 to 150	075	Samples
LM26LVCISDX-080/NOPB	ACTIVE	WSO	NGF	6	4500	Green (RoHS & no Sb/Br)	CU SN	Level-1-260C-UNLIM	0 to 150	080	Samples
LM26LVCISDX-085/NOPB	ACTIVE	WSO	NGF	6	4500	Green (RoHS & no Sb/Br)	CU SN	Level-1-260C-UNLIM	0 to 150	085	Samples
LM26LVCISDX-090/NOPB	ACTIVE	WSO	NGF	6	4500	Green (RoHS & no Sb/Br)	CU SN	Level-1-260C-UNLIM	0 to 150	090	Samples
LM26LVCISDX-095/NOPB	ACTIVE	WSO	NGF	6	4500	Green (RoHS & no Sb/Br)	CU SN	Level-1-260C-UNLIM	0 to 150	095	Samples
LM26LVCISDX-100/NOPB	ACTIVE	WSO	NGF	6	4500	Green (RoHS & no Sb/Br)	CU SN	Level-1-260C-UNLIM	0 to 150	100	Samples
LM26LVCISDX-105/NOPB	ACTIVE	WSO	NGF	6	4500	Green (RoHS & no Sb/Br)	CU SN	Level-1-260C-UNLIM	0 to 150	105	Samples
LM26LVCISDX-110/NOPB	ACTIVE	WSO	NGF	6	4500	Green (RoHS & no Sb/Br)	CU SN	Level-1-260C-UNLIM	0 to 150	110	Samples
LM26LVCISDX-115/NOPB	ACTIVE	WSO	NGF	6	4500	Green (RoHS & no Sb/Br)	CU SN	Level-1-260C-UNLIM	0 to 150	115	Samples
LM26LVCISDX-120/NOPB	ACTIVE	WSO	NGF	6	4500	Green (RoHS & no Sb/Br)	CU SN	Level-1-260C-UNLIM	0 to 150	120	Samples
LM26LVCISDX-125/NOPB	ACTIVE	WSO	NGF	6	4500	Green (RoHS & no Sb/Br)	CU SN	Level-1-260C-UNLIM	0 to 150	125	Samples

Orderable Device	Status (1)	Package Type	Package Drawing	Pins	Package Qty	Eco Plan (2)	Lead/Ball Finish	MSL Peak Temp (3)	Op Temp (°C)	Device Marking (4/5)	Samples
LM26LVCISDX-130/NOPB	ACTIVE	WSO	NGF	6	4500	Green (RoHS & no Sb/Br)	CU SN	Level-1-260C-UNLIM	0 to 150	130	Samples
LM26LVCISDX-135/NOPB	ACTIVE	WSO	NGF	6	4500	Green (RoHS & no Sb/Br)	CU SN	Level-1-260C-UNLIM	0 to 150	135	Samples
LM26LVCISDX-140/NOPB	ACTIVE	WSO	NGF	6	4500	Green (RoHS & no Sb/Br)	CU SN	Level-1-260C-UNLIM	0 to 150	140	Samples
LM26LVCISDX-145/NOPB	ACTIVE	WSO	NGF	6	4500	Green (RoHS & no Sb/Br)	CU SN	Level-1-260C-UNLIM	0 to 150	145	Samples
LM26LVCISDX-150/NOPB	ACTIVE	WSO	NGF	6	4500	Green (RoHS & no Sb/Br)	CU SN	Level-1-260C-UNLIM	0 to 150	150	Samples
LM26LVQISD-130/NOPB	ACTIVE	WSO	NGF	6	1000	Green (RoHS & no Sb/Br)	CU SN	Level-1-260C-UNLIM	-40 to 150	Q30	Samples
LM26LVQISD-135/NOPB	ACTIVE	WSO	NGF	6	1000	Green (RoHS & no Sb/Br)	CU SN	Level-1-260C-UNLIM	-40 to 150	Q35	Samples
LM26LVQISDX-130/NOPB	ACTIVE	WSO	NGF	6	4500	Green (RoHS & no Sb/Br)	CU SN	Level-1-260C-UNLIM	-40 to 150	Q30	Samples
LM26LVQISDX-135/NOPB	ACTIVE	WSO	NGF	6	4500	Green (RoHS & no Sb/Br)	CU SN	Level-1-260C-UNLIM	-40 to 150	Q35	Samples

(1) The marketing status values are defined as follows:

ACTIVE: Product device recommended for new designs.

LIFEBUY: TI has announced that the device will be discontinued, and a lifetime-buy period is in effect.

NRND: Not recommended for new designs. Device is in production to support existing customers, but TI does not recommend using this part in a new design.

PREVIEW: Device has been announced but is not in production. Samples may or may not be available.

OBSELETE: TI has discontinued the production of the device.

(2) Eco Plan - The planned eco-friendly classification: Pb-Free (RoHS), Pb-Free (RoHS Exempt), or Green (RoHS & no Sb/Br) - please check <http://www.ti.com/productcontent> for the latest availability information and additional product content details.

TBD: The Pb-Free/Green conversion plan has not been defined.

Pb-Free (RoHS): TI's terms "Lead-Free" or "Pb-Free" mean semiconductor products that are compatible with the current RoHS requirements for all 6 substances, including the requirement that lead not exceed 0.1% by weight in homogeneous materials. Where designed to be soldered at high temperatures, TI Pb-Free products are suitable for use in specified lead-free processes.

Pb-Free (RoHS Exempt): This component has a RoHS exemption for either 1) lead-based flip-chip solder bumps used between the die and package, or 2) lead-based die adhesive used between the die and leadframe. The component is otherwise considered Pb-Free (RoHS compatible) as defined above.

Green (RoHS & no Sb/Br): TI defines "Green" to mean Pb-Free (RoHS compatible), and free of Bromine (Br) and Antimony (Sb) based flame retardants (Br or Sb do not exceed 0.1% by weight in homogeneous material)

(3) MSL, Peak Temp. -- The Moisture Sensitivity Level rating according to the JEDEC industry standard classifications, and peak solder temperature.

(4) There may be additional marking, which relates to the logo, the lot trace code information, or the environmental category on the device.

(5) Multiple Device Markings will be inside parentheses. Only one Device Marking contained in parentheses and separated by a "~" will appear on a device. If a line is indented then it is a continuation of the previous line and the two combined represent the entire Device Marking for that device.

Important Information and Disclaimer:The information provided on this page represents TI's knowledge and belief as of the date that it is provided. TI bases its knowledge and belief on information provided by third parties, and makes no representation or warranty as to the accuracy of such information. Efforts are underway to better integrate information from third parties. TI has taken and continues to take reasonable steps to provide representative and accurate information but may not have conducted destructive testing or chemical analysis on incoming materials and chemicals. TI and TI suppliers consider certain information to be proprietary, and thus CAS numbers and other limited information may not be available for release.

In no event shall TI's liability arising out of such information exceed the total purchase price of the TI part(s) at issue in this document sold by TI to Customer on an annual basis.

OTHER QUALIFIED VERSIONS OF LM26LV, LM26LV-Q1 :

- Catalog: [LM26LV](#)
- Automotive: [LM26LV-Q1](#)

NOTE: Qualified Version Definitions:

- Catalog - TI's standard catalog product
- Automotive - Q100 devices qualified for high-reliability automotive applications targeting zero defects

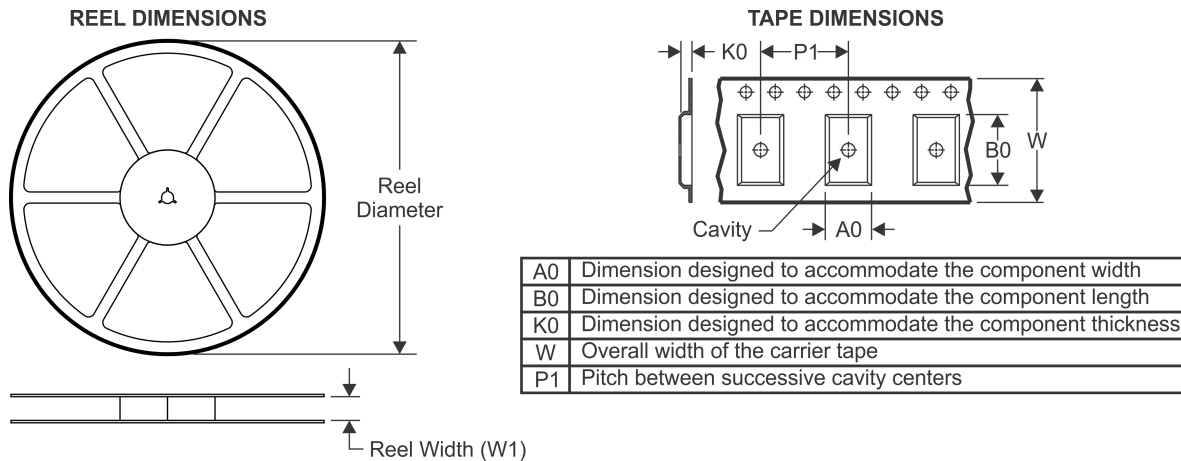
TAPE AND REEL INFORMATION

QUADRANT ASSIGNMENTS FOR PIN 1 ORIENTATION IN TAPE

*All dimensions are nominal

Device	Package Type	Package Drawing	Pins	SPQ	Reel Diameter (mm)	Reel Width W1 (mm)	A0 (mm)	B0 (mm)	K0 (mm)	P1 (mm)	W (mm)	Pin1 Quadrant
LM26LVCISD-050/NOPB	WSON	NGF	6	1000	178.0	12.4	2.8	2.5	1.0	8.0	12.0	Q1
LM26LVCISD-060/NOPB	WSON	NGF	6	1000	178.0	12.4	2.8	2.5	1.0	8.0	12.0	Q1
LM26LVCISD-065/NOPB	WSON	NGF	6	1000	178.0	12.4	2.8	2.5	1.0	8.0	12.0	Q1
LM26LVCISD-070/NOPB	WSON	NGF	6	1000	178.0	12.4	2.8	2.5	1.0	8.0	12.0	Q1
LM26LVCISD-075/NOPB	WSON	NGF	6	1000	178.0	12.4	2.8	2.5	1.0	8.0	12.0	Q1
LM26LVCISD-080/NOPB	WSON	NGF	6	1000	178.0	12.4	2.8	2.5	1.0	8.0	12.0	Q1
LM26LVCISD-085/NOPB	WSON	NGF	6	1000	178.0	12.4	2.8	2.5	1.0	8.0	12.0	Q1
LM26LVCISD-090/NOPB	WSON	NGF	6	1000	178.0	12.4	2.8	2.5	1.0	8.0	12.0	Q1
LM26LVCISD-095/NOPB	WSON	NGF	6	1000	178.0	12.4	2.8	2.5	1.0	8.0	12.0	Q1
LM26LVCISD-100/NOPB	WSON	NGF	6	1000	178.0	12.4	2.8	2.5	1.0	8.0	12.0	Q1
LM26LVCISD-105/NOPB	WSON	NGF	6	1000	178.0	12.4	2.8	2.5	1.0	8.0	12.0	Q1
LM26LVCISD-110/NOPB	WSON	NGF	6	1000	178.0	12.4	2.8	2.5	1.0	8.0	12.0	Q1
LM26LVCISD-115/NOPB	WSON	NGF	6	1000	178.0	12.4	2.8	2.5	1.0	8.0	12.0	Q1
LM26LVCISD-120/NOPB	WSON	NGF	6	1000	178.0	12.4	2.8	2.5	1.0	8.0	12.0	Q1
LM26LVCISD-125/NOPB	WSON	NGF	6	1000	178.0	12.4	2.8	2.5	1.0	8.0	12.0	Q1
LM26LVCISD-130/NOPB	WSON	NGF	6	1000	178.0	12.4	2.8	2.5	1.0	8.0	12.0	Q1
LM26LVCISD-135/NOPB	WSON	NGF	6	1000	178.0	12.4	2.8	2.5	1.0	8.0	12.0	Q1
LM26LVCISD-140/NOPB	WSON	NGF	6	1000	178.0	12.4	2.8	2.5	1.0	8.0	12.0	Q1

Device	Package Type	Package Drawing	Pins	SPQ	Reel Diameter (mm)	Reel Width W1 (mm)	A0 (mm)	B0 (mm)	K0 (mm)	P1 (mm)	W (mm)	Pin1 Quadrant
LM26LVCISD-145/NOPB	WSON	NGF	6	1000	178.0	12.4	2.8	2.5	1.0	8.0	12.0	Q1
LM26LVCISD-150/NOPB	WSON	NGF	6	1000	178.0	12.4	2.8	2.5	1.0	8.0	12.0	Q1
LM26LVCISDX-050/NOPB	WSON	NGF	6	4500	330.0	12.4	2.8	2.5	1.0	8.0	12.0	Q1
LM26LVCISDX-060/NOPB	WSON	NGF	6	4500	330.0	12.4	2.8	2.5	1.0	8.0	12.0	Q1
LM26LVCISDX-065/NOPB	WSON	NGF	6	4500	330.0	12.4	2.8	2.5	1.0	8.0	12.0	Q1
LM26LVCISDX-070/NOPB	WSON	NGF	6	4500	330.0	12.4	2.8	2.5	1.0	8.0	12.0	Q1
LM26LVCISDX-075/NOPB	WSON	NGF	6	4500	330.0	12.4	2.8	2.5	1.0	8.0	12.0	Q1
LM26LVCISDX-080/NOPB	WSON	NGF	6	4500	330.0	12.4	2.8	2.5	1.0	8.0	12.0	Q1
LM26LVCISDX-085/NOPB	WSON	NGF	6	4500	330.0	12.4	2.8	2.5	1.0	8.0	12.0	Q1
LM26LVCISDX-090/NOPB	WSON	NGF	6	4500	330.0	12.4	2.8	2.5	1.0	8.0	12.0	Q1
LM26LVCISDX-095/NOPB	WSON	NGF	6	4500	330.0	12.4	2.8	2.5	1.0	8.0	12.0	Q1
LM26LVCISDX-100/NOPB	WSON	NGF	6	4500	330.0	12.4	2.8	2.5	1.0	8.0	12.0	Q1
LM26LVCISDX-105/NOPB	WSON	NGF	6	4500	330.0	12.4	2.8	2.5	1.0	8.0	12.0	Q1
LM26LVCISDX-110/NOPB	WSON	NGF	6	4500	330.0	12.4	2.8	2.5	1.0	8.0	12.0	Q1
LM26LVCISDX-115/NOPB	WSON	NGF	6	4500	330.0	12.4	2.8	2.5	1.0	8.0	12.0	Q1
LM26LVCISDX-120/NOPB	WSON	NGF	6	4500	330.0	12.4	2.8	2.5	1.0	8.0	12.0	Q1
LM26LVCISDX-125/NOPB	WSON	NGF	6	4500	330.0	12.4	2.8	2.5	1.0	8.0	12.0	Q1
LM26LVCISDX-130/NOPB	WSON	NGF	6	4500	330.0	12.4	2.8	2.5	1.0	8.0	12.0	Q1
LM26LVCISDX-135/NOPB	WSON	NGF	6	4500	330.0	12.4	2.8	2.5	1.0	8.0	12.0	Q1
LM26LVCISDX-140/NOPB	WSON	NGF	6	4500	330.0	12.4	2.8	2.5	1.0	8.0	12.0	Q1
LM26LVCISDX-145/NOPB	WSON	NGF	6	4500	330.0	12.4	2.8	2.5	1.0	8.0	12.0	Q1
LM26LVCISDX-150/NOPB	WSON	NGF	6	4500	330.0	12.4	2.8	2.5	1.0	8.0	12.0	Q1
LM26LVQISD-130/NOPB	WSON	NGF	6	1000	178.0	12.4	2.8	2.5	1.0	8.0	12.0	Q1
LM26LVQISDX-130/NOP B	WSON	NGF	6	4500	330.0	12.4	2.8	2.5	1.0	8.0	12.0	Q1

TAPE AND REEL BOX DIMENSIONS

*All dimensions are nominal

Device	Package Type	Package Drawing	Pins	SPQ	Length (mm)	Width (mm)	Height (mm)
LM26LVCISD-050/NOPB	WSON	NGF	6	1000	210.0	185.0	35.0
LM26LVCISD-060/NOPB	WSON	NGF	6	1000	210.0	185.0	35.0
LM26LVCISD-065/NOPB	WSON	NGF	6	1000	210.0	185.0	35.0
LM26LVCISD-070/NOPB	WSON	NGF	6	1000	210.0	185.0	35.0
LM26LVCISD-075/NOPB	WSON	NGF	6	1000	210.0	185.0	35.0
LM26LVCISD-080/NOPB	WSON	NGF	6	1000	210.0	185.0	35.0
LM26LVCISD-085/NOPB	WSON	NGF	6	1000	210.0	185.0	35.0
LM26LVCISD-090/NOPB	WSON	NGF	6	1000	210.0	185.0	35.0
LM26LVCISD-095/NOPB	WSON	NGF	6	1000	210.0	185.0	35.0
LM26LVCISD-100/NOPB	WSON	NGF	6	1000	210.0	185.0	35.0
LM26LVCISD-105/NOPB	WSON	NGF	6	1000	210.0	185.0	35.0
LM26LVCISD-110/NOPB	WSON	NGF	6	1000	210.0	185.0	35.0
LM26LVCISD-115/NOPB	WSON	NGF	6	1000	210.0	185.0	35.0
LM26LVCISD-120/NOPB	WSON	NGF	6	1000	210.0	185.0	35.0
LM26LVCISD-125/NOPB	WSON	NGF	6	1000	210.0	185.0	35.0
LM26LVCISD-130/NOPB	WSON	NGF	6	1000	210.0	185.0	35.0
LM26LVCISD-135/NOPB	WSON	NGF	6	1000	210.0	185.0	35.0
LM26LVCISD-140/NOPB	WSON	NGF	6	1000	210.0	185.0	35.0
LM26LVCISD-145/NOPB	WSON	NGF	6	1000	210.0	185.0	35.0
LM26LVCISD-150/NOPB	WSON	NGF	6	1000	210.0	185.0	35.0

Device	Package Type	Package Drawing	Pins	SPQ	Length (mm)	Width (mm)	Height (mm)
LM26LVCISDX-050/NOPB	WSON	NGF	6	4500	367.0	367.0	35.0
LM26LVCISDX-060/NOPB	WSON	NGF	6	4500	367.0	367.0	35.0
LM26LVCISDX-065/NOPB	WSON	NGF	6	4500	367.0	367.0	35.0
LM26LVCISDX-070/NOPB	WSON	NGF	6	4500	367.0	367.0	35.0
LM26LVCISDX-075/NOPB	WSON	NGF	6	4500	367.0	367.0	35.0
LM26LVCISDX-080/NOPB	WSON	NGF	6	4500	367.0	367.0	35.0
LM26LVCISDX-085/NOPB	WSON	NGF	6	4500	367.0	367.0	35.0
LM26LVCISDX-090/NOPB	WSON	NGF	6	4500	367.0	367.0	35.0
LM26LVCISDX-095/NOPB	WSON	NGF	6	4500	367.0	367.0	35.0
LM26LVCISDX-100/NOPB	WSON	NGF	6	4500	367.0	367.0	35.0
LM26LVCISDX-105/NOPB	WSON	NGF	6	4500	367.0	367.0	35.0
LM26LVCISDX-110/NOPB	WSON	NGF	6	4500	367.0	367.0	35.0
LM26LVCISDX-115/NOPB	WSON	NGF	6	4500	367.0	367.0	35.0
LM26LVCISDX-120/NOPB	WSON	NGF	6	4500	367.0	367.0	35.0
LM26LVCISDX-125/NOPB	WSON	NGF	6	4500	367.0	367.0	35.0
LM26LVCISDX-130/NOPB	WSON	NGF	6	4500	367.0	367.0	35.0
LM26LVCISDX-135/NOPB	WSON	NGF	6	4500	367.0	367.0	35.0
LM26LVCISDX-140/NOPB	WSON	NGF	6	4500	367.0	367.0	35.0
LM26LVCISDX-145/NOPB	WSON	NGF	6	4500	367.0	367.0	35.0
LM26LVCISDX-150/NOPB	WSON	NGF	6	4500	367.0	367.0	35.0
LM26LVQISD-130/NOPB	WSON	NGF	6	1000	210.0	185.0	35.0
LM26LVQISDX-130/NOPB	WSON	NGF	6	4500	367.0	367.0	35.0

NGF0006A

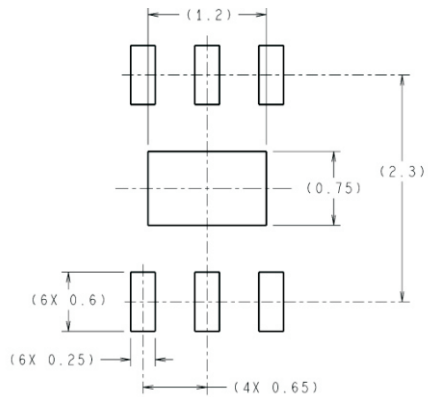

DIMENSIONS ARE IN MILLIMETERS
DIMENSIONS IN () FOR REFERENCE ONLY

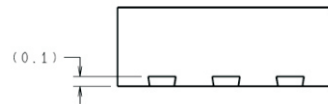

RECOMMENDED LAND PATTERN

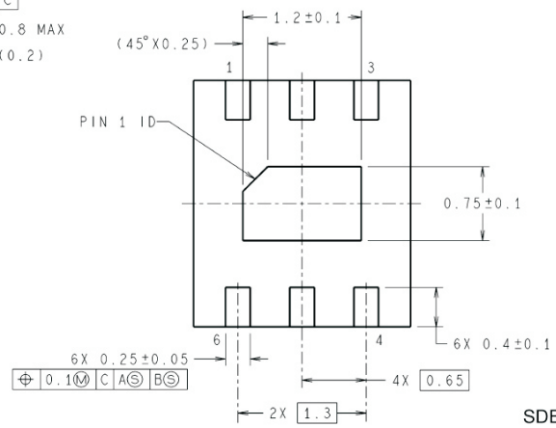
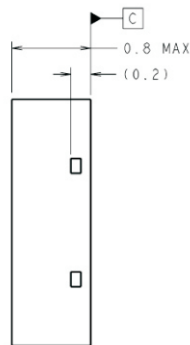
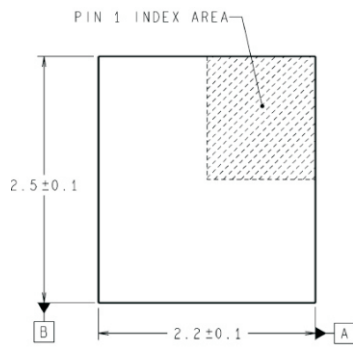

SDB06A (Rev A)

IMPORTANT NOTICE

Texas Instruments Incorporated and its subsidiaries (TI) reserve the right to make corrections, enhancements, improvements and other changes to its semiconductor products and services per JESD46, latest issue, and to discontinue any product or service per JESD48, latest issue. Buyers should obtain the latest relevant information before placing orders and should verify that such information is current and complete. All semiconductor products (also referred to herein as "components") are sold subject to TI's terms and conditions of sale supplied at the time of order acknowledgment.

TI warrants performance of its components to the specifications applicable at the time of sale, in accordance with the warranty in TI's terms and conditions of sale of semiconductor products. Testing and other quality control techniques are used to the extent TI deems necessary to support this warranty. Except where mandated by applicable law, testing of all parameters of each component is not necessarily performed.

TI assumes no liability for applications assistance or the design of Buyers' products. Buyers are responsible for their products and applications using TI components. To minimize the risks associated with Buyers' products and applications, Buyers should provide adequate design and operating safeguards.

TI does not warrant or represent that any license, either express or implied, is granted under any patent right, copyright, mask work right, or other intellectual property right relating to any combination, machine, or process in which TI components or services are used. Information published by TI regarding third-party products or services does not constitute a license to use such products or services or a warranty or endorsement thereof. Use of such information may require a license from a third party under the patents or other intellectual property of the third party, or a license from TI under the patents or other intellectual property of TI.

Reproduction of significant portions of TI information in TI data books or data sheets is permissible only if reproduction is without alteration and is accompanied by all associated warranties, conditions, limitations, and notices. TI is not responsible or liable for such altered documentation. Information of third parties may be subject to additional restrictions.

Resale of TI components or services with statements different from or beyond the parameters stated by TI for that component or service voids all express and any implied warranties for the associated TI component or service and is an unfair and deceptive business practice. TI is not responsible or liable for any such statements.

Buyer acknowledges and agrees that it is solely responsible for compliance with all legal, regulatory and safety-related requirements concerning its products, and any use of TI components in its applications, notwithstanding any applications-related information or support that may be provided by TI. Buyer represents and agrees that it has all the necessary expertise to create and implement safeguards which anticipate dangerous consequences of failures, monitor failures and their consequences, lessen the likelihood of failures that might cause harm and take appropriate remedial actions. Buyer will fully indemnify TI and its representatives against any damages arising out of the use of any TI components in safety-critical applications.

In some cases, TI components may be promoted specifically to facilitate safety-related applications. With such components, TI's goal is to help enable customers to design and create their own end-product solutions that meet applicable functional safety standards and requirements. Nonetheless, such components are subject to these terms.

No TI components are authorized for use in FDA Class III (or similar life-critical medical equipment) unless authorized officers of the parties have executed a special agreement specifically governing such use.

Only those TI components which TI has specifically designated as military grade or "enhanced plastic" are designed and intended for use in military/aerospace applications or environments. Buyer acknowledges and agrees that any military or aerospace use of TI components which have **not** been so designated is solely at the Buyer's risk, and that Buyer is solely responsible for compliance with all legal and regulatory requirements in connection with such use.

TI has specifically designated certain components as meeting ISO/TS16949 requirements, mainly for automotive use. In any case of use of non-designated products, TI will not be responsible for any failure to meet ISO/TS16949.

Products

Audio	www.ti.com/audio
Amplifiers	amplifier.ti.com
Data Converters	dataconverter.ti.com
DLP® Products	www.dlp.com
DSP	dsp.ti.com
Clocks and Timers	www.ti.com/clocks
Interface	interface.ti.com
Logic	logic.ti.com
Power Mgmt	power.ti.com
Microcontrollers	microcontroller.ti.com
RFID	www.ti-rfid.com
OMAP Applications Processors	www.ti.com/omap
Wireless Connectivity	www.ti.com/wirelessconnectivity

Applications

Automotive and Transportation	www.ti.com/automotive
Communications and Telecom	www.ti.com/communications
Computers and Peripherals	www.ti.com/computers
Consumer Electronics	www.ti.com/consumer-apps
Energy and Lighting	www.ti.com/energy
Industrial	www.ti.com/industrial
Medical	www.ti.com/medical
Security	www.ti.com/security
Space, Avionics and Defense	www.ti.com/space-avionics-defense
Video and Imaging	www.ti.com/video

TI E2E Community

e2e.ti.com