

DS3669

DS3669 Quad High Current Peripheral Driver



Literature Number: SNLS366A

DS3669 Quad High Current Peripheral Driver

General Description

The DS3669 is a non-inverting quad peripheral driver similar to the DS3658. These drivers are designed for those applications where low operating power, high breakdown voltage, high output current and low output ON voltage are required. A unique input circuit combines TTL compatibility with high impedance. In fact, its extreme low input current allows it to be driven directly by a CMOS device.

The outputs are capable of sinking 600 mA each and offer a 70V breakdown. However, for inductive loads the output should be clamped to 35V or less to avoid latch-up during turn off (inductive fly back protection—refer AN-213). An on-chip clamp diode capable of handling 800 mA is provided at each output for this purpose. In addition, the DS3669 incorporates circuitry that guarantees glitch-free power up or down operation.

The molded package is specifically constructed to allow increased power dissipation over conventional packages. The four ground pins are directly connected to the device chip with a special copper lead frame. When the quad driver is soldered into a PC board, the power rating of the device improves significantly.

Applications

- Relay drivers
- Lamp drivers
- Solenoid drivers
- Hammer drivers

- Stepping motor drivers
- Triac drivers
- LED drivers
- High current, high voltage drivers
- Level translators
- Fiber optic LED drivers

Features

- Single saturated transistor outputs
- Low standby power, 10 mW typical
- High impedance TTL compatible inputs
- Outputs may be tied together for increased current capacity
- High output current
 - 600 mA per output
 - 2.4A per package
- No output latch-up at 35V
- Low output ON voltage (350 mV typ @600 mA)
- High breakdown voltage (70V)
- Open collector outputs
- Output clamp diodes for inductive fly back protection
- NPN inputs for minimal input currents (1 μ A typical)
- Low operating power
- Standard 5V power supply
- Power up/down protection
- 2W power package

Connection Diagram

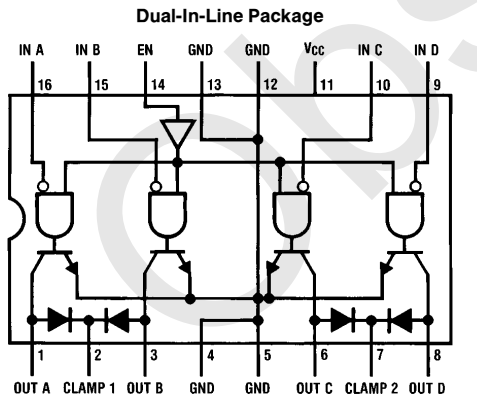

Top View

Order Number DS3669N
See NS Package Number N16E

Truth Table

IN	EN	OUT
L	H	L
H	H	Z
L	L	Z
H	L	Z

H = High state
L = Low state
Z = High impedance state

Absolute Maximum Ratings (Note 1)

If Military/Aerospace specified devices are required, please contact the National Semiconductor Sales Office/Distributors for availability and specifications.

Supply Voltage	7.0V
Input Voltage	15V
Output Voltage	70V
Output Current	1.5A
Continuous Power Dissipation @25°C Free-Air (Note 5)	2075 mW

Storage Temperature Range	-65°C to +150°C
Lead Temperature (Soldering, 4 seconds)	260°C

Operating Conditions

	Min	Max	Units
Supply Voltage	4.75	5.25	V
Ambient Temperature	0	70	°C

Electrical Characteristics (Notes 2 and 3)

Symbol	Parameter	Conditions	Min	Typ	Max	Units
V _{IH}	Input High Voltage		2.0			V
V _{IL}	Input Low Voltage				0.8	V
I _{IH}	Input High Current	V _{IN} = 5.25V, V _{CC} = 5.25V		1.0	10	μA
I _{IL}	Input Low Current	V _{IN} = 0.4V			±10	μA
V _{IK}	Input Clamp Voltage	I _I = -12 mA		-0.8	-1.5	V
V _{OL}	Output Low Voltage	I _L = 300 mA		0.2	0.4	V
		I _L = 600 mA (Note 4)		0.35	0.7	V
I _{CEx}	Output Leakage Current	V _C = 70V, V _{IN} = 2V, V _{EN} = 0.8V			100	μA
V _F	Diode Forward Voltage	I _F = 800 mA		1.0	1.6	V
I _R	Diode Leakage Current	V _R = 70V			100	μA
I _{CC}	Supply Current	All Inputs Low EN = 2.0V		60	85	mA
		All Inputs High		2	4	mA

Switching Characteristics (Note 2)

Symbol	Parameter	Conditions	Min	Typ	Max	Units
t _{PHL}	Turn On Delay	R _L = 60Ω, V _L = 30V		226	500	ns
t _{PLH}	Turn Off Delay	R _L = 60Ω, V _L = 30V		2430	8000	ns

Note 1: "Absolute Maximum Ratings" are those values beyond which the safety of the device cannot be guaranteed. They are not meant to imply that the device should be operated at these limits. The table of "Electrical Characteristics" provides conditions for actual device operation.

Note 2: Unless otherwise specified, min/max limits apply across the 0°C to +70°C temperature range and the 4.75V to 5.25V power supply range. All typical values are for T_A = 25°C and V_{CC} = 5.0V.

Note 3: All currents into device pins are shown as positive; all currents out of device pins are shown as negative; all voltages are referenced to ground, unless otherwise specified. All values shown as max or min are so classified on absolute value basis.

Note 4: All sections of this quad circuit may conduct rated current simultaneously; however, power dissipation averaged over a short interval of time must fall within specified continuous dissipation ratings.

Note 5: For operation over 25°C free-air temperature, derate linearly to 1328 mW @70°C @ the rate of 16.6 mW/°C.

AC Test Circuit

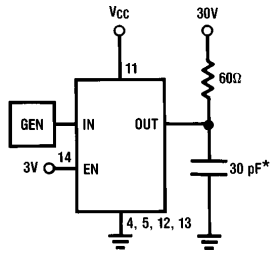

TL/F/5820-2

*Includes probe and jig capacitance

Switching Waveforms

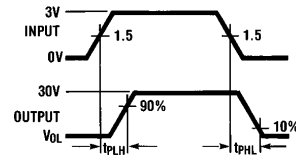

TL/F/5820-3

Typical Applications

Stepping Motor Driver

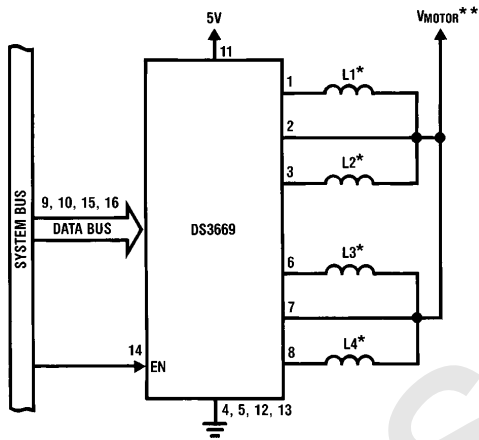

TL/F/5820-4

*L1, L2, L3, L4 are the windings of a bifilar stepping motor.
 **V_{MOTOR} is the supply voltage of the motor.

Lamp Driver

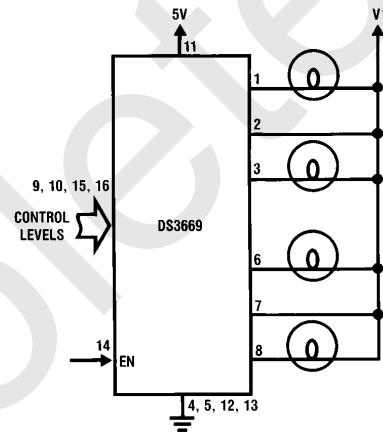

TL/F/5820-5

Physical Dimensions inches (millimeters)

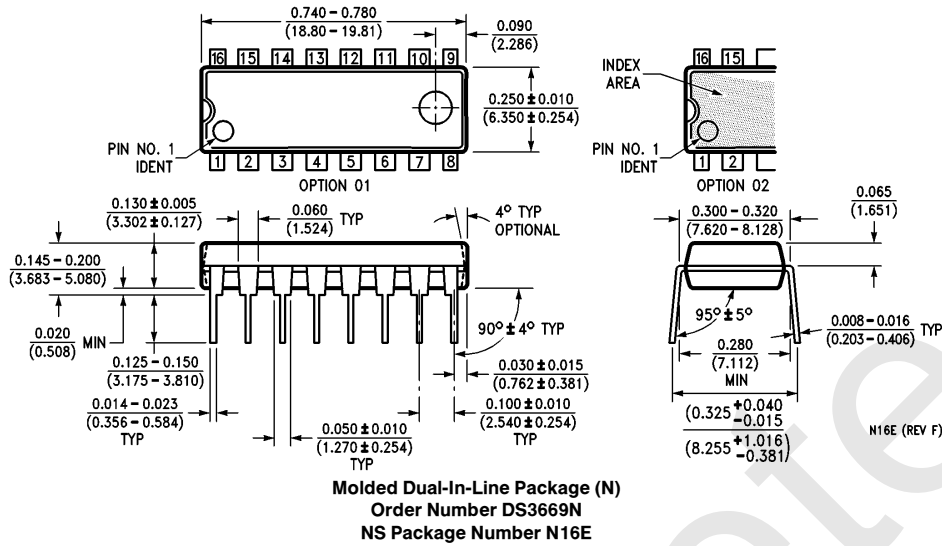

LIFE SUPPORT POLICY

NATIONAL'S PRODUCTS ARE NOT AUTHORIZED FOR USE AS CRITICAL COMPONENTS IN LIFE SUPPORT DEVICES OR SYSTEMS WITHOUT THE EXPRESS WRITTEN APPROVAL OF THE PRESIDENT OF NATIONAL SEMICONDUCTOR CORPORATION. As used herein:

1. Life support devices or systems are devices or systems which, (a) are intended for surgical implant into the body, or (b) support or sustain life, and whose failure to perform, when properly used in accordance with instructions for use provided in the labeling, can be reasonably expected to result in a significant injury to the user.
2. A critical component is any component of a life support device or system whose failure to perform can be reasonably expected to cause the failure of the life support device or system, or to affect its safety or effectiveness.



National Semiconductor Corporation
 1111 West Bardin Road
 Arlington, TX 76017
 Tel: 1(800) 272-9959
 Fax: 1(800) 737-7018

National Semiconductor Europe
 Fax: (+49) 0-180-530 85 86
 Email: cnjwge@tevm2.nsc.com
 Deutsch Tel: (+49) 0-180-530 85 85
 English Tel: (+49) 0-180-532 78 32
 Français Tel: (+49) 0-180-532 93 58
 Italiano Tel: (+49) 0-180-534 16 80

National Semiconductor Hong Kong Ltd.
 19th Floor, Straight Block,
 Ocean Centre, 5 Canton Rd.
 Tsimshatsui, Kowloon
 Hong Kong
 Tel: (852) 2737-1600
 Fax: (852) 2736-9960

National Semiconductor Japan Ltd.
 Tel: 81-043-299-2309
 Fax: 81-043-299-2408

National does not assume any responsibility for use of any circuitry described, no circuit patent licenses are implied and National reserves the right at any time without notice to change said circuitry and specifications.

IMPORTANT NOTICE

Texas Instruments Incorporated and its subsidiaries (TI) reserve the right to make corrections, modifications, enhancements, improvements, and other changes to its products and services at any time and to discontinue any product or service without notice. Customers should obtain the latest relevant information before placing orders and should verify that such information is current and complete. All products are sold subject to TI's terms and conditions of sale supplied at the time of order acknowledgment.

TI warrants performance of its hardware products to the specifications applicable at the time of sale in accordance with TI's standard warranty. Testing and other quality control techniques are used to the extent TI deems necessary to support this warranty. Except where mandated by government requirements, testing of all parameters of each product is not necessarily performed.

TI assumes no liability for applications assistance or customer product design. Customers are responsible for their products and applications using TI components. To minimize the risks associated with customer products and applications, customers should provide adequate design and operating safeguards.

TI does not warrant or represent that any license, either express or implied, is granted under any TI patent right, copyright, mask work right, or other TI intellectual property right relating to any combination, machine, or process in which TI products or services are used. Information published by TI regarding third-party products or services does not constitute a license from TI to use such products or services or a warranty or endorsement thereof. Use of such information may require a license from a third party under the patents or other intellectual property of the third party, or a license from TI under the patents or other intellectual property of TI.

Reproduction of TI information in TI data books or data sheets is permissible only if reproduction is without alteration and is accompanied by all associated warranties, conditions, limitations, and notices. Reproduction of this information with alteration is an unfair and deceptive business practice. TI is not responsible or liable for such altered documentation. Information of third parties may be subject to additional restrictions.

Resale of TI products or services with statements different from or beyond the parameters stated by TI for that product or service voids all express and any implied warranties for the associated TI product or service and is an unfair and deceptive business practice. TI is not responsible or liable for any such statements.

TI products are not authorized for use in safety-critical applications (such as life support) where a failure of the TI product would reasonably be expected to cause severe personal injury or death, unless officers of the parties have executed an agreement specifically governing such use. Buyers represent that they have all necessary expertise in the safety and regulatory ramifications of their applications, and acknowledge and agree that they are solely responsible for all legal, regulatory and safety-related requirements concerning their products and any use of TI products in such safety-critical applications, notwithstanding any applications-related information or support that may be provided by TI. Further, Buyers must fully indemnify TI and its representatives against any damages arising out of the use of TI products in such safety-critical applications.

TI products are neither designed nor intended for use in military/aerospace applications or environments unless the TI products are specifically designated by TI as military-grade or "enhanced plastic." Only products designated by TI as military-grade meet military specifications. Buyers acknowledge and agree that any such use of TI products which TI has not designated as military-grade is solely at the Buyer's risk, and that they are solely responsible for compliance with all legal and regulatory requirements in connection with such use.

TI products are neither designed nor intended for use in automotive applications or environments unless the specific TI products are designated by TI as compliant with ISO/TS 16949 requirements. Buyers acknowledge and agree that, if they use any non-designated products in automotive applications, TI will not be responsible for any failure to meet such requirements.

Following are URLs where you can obtain information on other Texas Instruments products and application solutions:

Products

Audio	www.ti.com/audio
Amplifiers	amplifier.ti.com
Data Converters	dataconverter.ti.com
DLP® Products	www.dlp.com
DSP	dsp.ti.com
Clocks and Timers	www.ti.com/clocks
Interface	interface.ti.com
Logic	logic.ti.com
Power Mgmt	power.ti.com
Microcontrollers	microcontroller.ti.com
RFID	www.ti-rfid.com
OMAP Mobile Processors	www.ti.com/omap
Wireless Connectivity	www.ti.com/wirelessconnectivity

Applications

Communications and Telecom	www.ti.com/communications
Computers and Peripherals	www.ti.com/computers
Consumer Electronics	www.ti.com/consumer-apps
Energy and Lighting	www.ti.com/energy
Industrial	www.ti.com/industrial
Medical	www.ti.com/medical
Security	www.ti.com/security
Space, Avionics and Defense	www.ti.com/space-avionics-defense
Transportation and Automotive	www.ti.com/automotive
Video and Imaging	www.ti.com/video

TI E2E Community Home Page

e2e.ti.com

Mailing Address: Texas Instruments, Post Office Box 655303, Dallas, Texas 75265
Copyright © 2011, Texas Instruments Incorporated