

## SCANPSC100F Embedded Boundary Scan Controller (IEEE 1149.1 Support)

Check for Samples: [SCANPSC100F](#)

### FEATURES

- **Compatible with IEEE Std. 1149.1 (JTAG) Test Access Port and Boundary Scan Architecture**
- **Supported by Texas Instruments SCAN Ease (Embedded Application Software Enabler) Software**
- **Uses Generic, Asynchronous Processor Interface; Compatible with a Wide Range of Processors and PCLK Frequencies**
- **Directly Supports Up to Two 1149.1 Scan Chains**
- **16-bit Serial Signature Compaction (SSC) at the Test Data In (TDI) Port**
- **Automatically Produces Pseudo-Random Patterns at the Test Data Out (TDO) Port**
- **Fabricated on FACT™ 1.5 μm CMOS Process**
- **Supports 1149.1 Test Clock (TCK) Frequencies up to 25 MHz**
- **TTL-Compatible Inputs; Full-Swing CMOS Outputs with 24 mA Source/Sink Capability**
- **Standard Microcircuit Drawing (SMD) 5962-9475001**

### Connection Diagrams

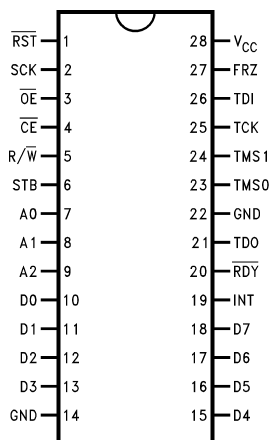

Figure 1. 28-Pin CDIP and CLGA

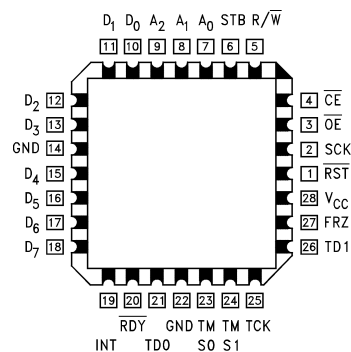

Figure 2. Pin Assignment for LCCC



Please be aware that an important notice concerning availability, standard warranty, and use in critical applications of Texas Instruments semiconductor products and disclaimers thereto appears at the end of this data sheet.

FACT is a trademark of Fairchild Semiconductor.

All other trademarks are the property of their respective owners.

## Chip Architecture

The 'PSC100 is designed to act together with a parallel bus host as a serial test bus master. Parallel data is written by the host to the 'PSC100, which serializes the data for application to a serial test bus. Serial data returning from the target scan chain(s) is placed on the processor port for parallel reads. Several features are included in the 'PSC100 which make scan test communication more convenient and efficient.

**Figure 3** shows the major functional blocks of the 'PSC100 design. The Parallel Processor Interface (PPI) is an asynchronous, 8-bit parallel interface which is used by the host processor to write and read data. The PPI generates the necessary internal data, address, and control signals to complete internal write and read operations.

The Serial Scan Interface (SSI) consists of a bank of double-buffered parallel/serial shift registers (i.e., a 2 x 8 bit FIFO), or Shifter/Buffers. The double buffering improves efficiency by allowing parallel writes or reads to/from one of the two 8-bit FIFOs within the shifter/buffer while the other FIFO is shifting data to/from the scan chain. Three Shifter/Buffers are provided for outgoing serial data and one for incoming serial data. Test Data Out (TDO) is for scanning out test data while the two Test Mode Select signals (TMS0/1) are used to provide user specific control data. Test Data In (TDI) receives serial data from the scan chain. A local control block is associated with each Shifter/Buffer to provide shift and load control as well as providing full or empty status. The SSI also provides Test Clock (TCK) Control. TCK is stopped and started depending on the status of the Shifter/Buffers or the 32-bit Counter. By stopping and starting TCK, scan operations will proceed only when the enabled Shifter/Buffers are ready to send and/or receive serial data.

The 32-bit Counter (CNT32) is a count-down binary counter included to assist in controlling the SSI. The initial state of CNT32 is loaded from the parallel port with four consecutive writes to its address. When enabled, CNT32 is used to program the number of TCKs applied by the SSI to the boundary scan chain(s). The value of CNT32 can also be used to generate interrupts (i.e., when CNT32 reaches terminal count) and to trigger 'PSC100 features, such as, Auto TMS High (discussed later within this datasheet).

The Mode and Status Registers are used to control and observe the operation of the SSI and CNT32. Each of the Shifter/Buffers and CNT32 have an associated mode bit which enables it for participation in on-going operations. Status bits can be used for polling operations.

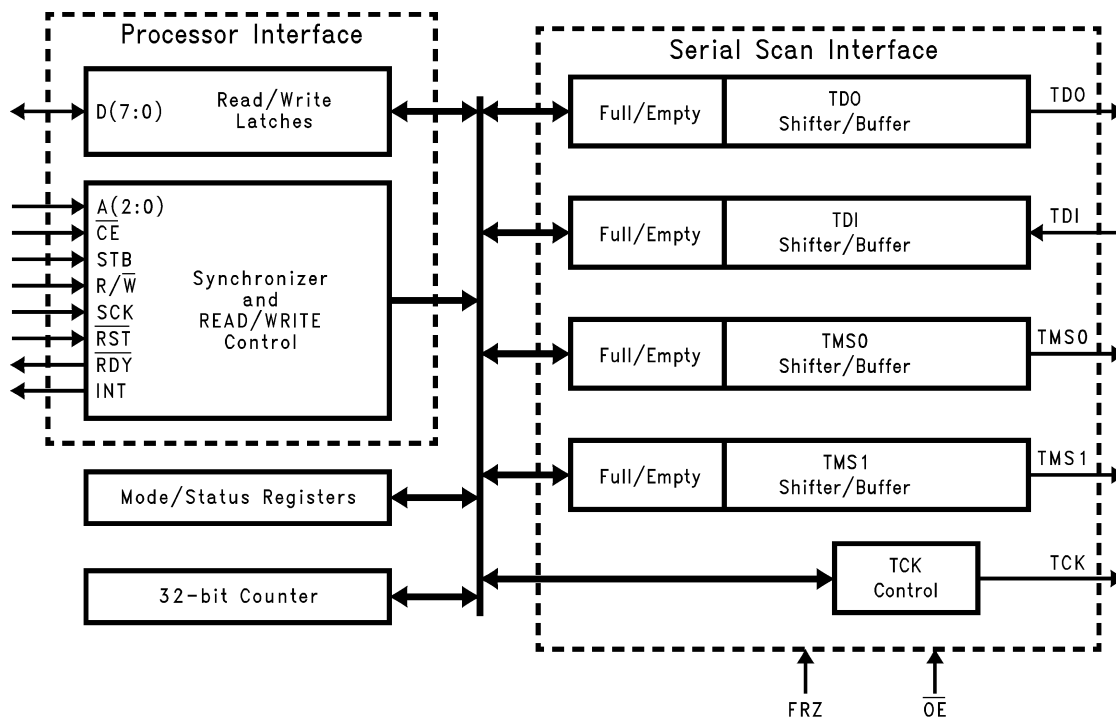

**Figure 3. 'PSC100 Block Diagram**

### PIN DESCRIPTIONS

Pin Name	Description
$\overline{\text{RST}}$ (Input)	The Reset pin is an asynchronous input that, when low, initializes the 'PSC100. Mode bits, Shifter/Buffer and CNT32 control logic, TCK Control, and the PPI are all initialized to defined states. $\overline{\text{RST}}$ has hysteresis for improved noise immunity.
<b>SCK</b> (Input)	The System Clock drives all internal timing. The test clock, TCK, is a gated and buffered version of SCK. SCK has hysteresis for improved immunity.
$\overline{\text{OE}}$ (Input)	Output Enable Tri-States all SSI outputs when high. A 20 k $\Omega$ pull-up resistor is connected to automatically Tri-State these outputs when this signal is floating.
$\overline{\text{CE}}$ (Input)	Chip Enable, when low, enables the PPI for byte transfers. D(7:0) and $\overline{\text{RDY}}$ are Tri-States if $\overline{\text{CE}}$ is high. $\overline{\text{CE}}$ has hysteresis for improved noise immunity.
$\overline{\text{R/W}}$ (Input)	Read/Write defines a PPI cycle—Read when high, Write when low. $\overline{\text{R/W}}$ has hysteresis for improved noise immunity.
<b>STB</b> (Input)	Strobe is used for timing all PPI byte transfers. D(7:0) are Tri-States when STB is high. All other PPI inputs must meet specified setup and hold times with respect to this signal. STB has hysteresis for improved noise immunity.
<b>A(2:0)</b> (Input)	The Address pins are used to select the register to be written to or read from.
<b>D(7:0)</b> (I/O)	Bidirectional pins used to transfer parallel data to and from the 'PSC100.
<b>INT</b> (Output)	Interrupt is used to trigger a host interrupt for any of the defined interrupt events. INT is active high.
$\overline{\text{RDY}}$ (Tri-State Output)	Ready is used to synchronize asynchronous byte transfers between the host and the 'PSC100. When low, $\overline{\text{RDY}}$ signals that the addressed register is ready to be accessed $\overline{\text{RDY}}$ is enabled when $\overline{\text{CE}}$ is low.
<b>TDO</b> (Tri-State Output)	Test Data Out is the serial scan output from the 'PSC100. TDO is enabled when $\overline{\text{OE}}$ is low.
<b>TMS(1:0)</b> (Tri-State Output)	The Test Mode Select pins are serial outputs used to supply control logic to the UUT. TMS(1:0) are enabled when $\overline{\text{OE}}$ is low.
<b>TCK</b> (Tri-State Output)	The Test Clock output is a buffered version of SCK for distribution in the UUT. TCK Control logic starts and stops TCK to prevent overflow and underflow conditions. TCK is enabled when $\overline{\text{OE}}$ is low.
<b>TDI</b> (Input)	Test Data In is the serial scan input to the 'PSC100. A 20 k $\Omega$ pull-up resistor is connected to force TDI to a logic 1 when the TDO line from the UUT is floating.
<b>FRZ</b> (Input)	The Freeze pin is used to asynchronously generate a user-specific pulse on TCK. If the FRZ Enable Mode bit is set, TCK will be forced high if FRZ goes high. FRZ has hysteresis for improved noise immunity.

### MODE AND STATUS REGISTERS

#### Mode Register 0 (Mode0)

Bit 7	Bit 6	Bit 5	Bit 4	Bit 3	Bit 2	Bit 1	Bit 0
TDO Enable	TDI Enable	CNT32 Enable	TMS0 Enable	TMS1 Enable	Reserved	Auto TMS High Enable	Loop-Around Enable

This register is purely a mode register. All bits are writeable and readable. The value 00100000 is placed in this register upon  $\overline{\text{RST}}$  low or a synchronous reset operation.

- **Bit 7:** This bit enables the TDO shifter/buffer for shift operations. If this bit is set, the TDO shifter/buffer will cause TCK to stop if it is empty.
- **Bit 6:** This bit enables the TDI shifter/buffer for shift operations. If this bit is set, the TDI shifter/buffer will cause TCK to stop if it is full.
- **Bit 5:** This bit enables the 32-bit counter. If this bit is set, the counter will cause TCK to stop if it has not been loaded or if it has reached terminal count.
- **Bit 4:** This bit enables the TMS0 shifter/buffer for shift operations. If this bit is set, the TMS0 shifter/buffer will cause TCK to stop if it is empty.
- **Bit 3:** This bit enables the TMS1 shifter/buffer for shift operations. If this bit is set, the TMS1 shifter/buffer will cause TCK to stop if it is empty.
- **Bit 2:** This bit is reserved and should remain as a logic 0 during all 'PSC100 operations.
- **Bit 1:** If this bit is set, TMS will be forced high when the 32-bit counter is at state (0000001)h.
- **Bit 0:** This bit causes TDI to be connected directly back through TDO for Loop-Around operations.

**Mode Register 1 (Mode1)**

Bit 7	Bit 6	Bit 5	Bit 4	Bit 3	Bit 2	Bit 1	Bit 0
TDO Interrupt Enable	TDI Interrupt Enable	CNT32 Interrupt Enable	PRPG Enable	SSC Enable	Freeze Pin Enable	Test Loop- Back	Test Loop- Back

This register is purely a mode register. All bits are writeable and readable. The value 00000000 is placed in this register upon  $\overline{\text{RST}}$  low or a synchronous reset operation.

- **Bit 7:** If this bit is set and the TDO shifter/buffer is not full (i.e., one or both 8-bit TDO FIFOs are empty), the INT pin will go high.
- **Bit 6:** If this bit is set and the TDI shifter/buffer is not empty (i.e., one or both 8-bit TDI FIFOs are full), the INT pin will go high.
- **Bit 5:** If this bit is set, and the 32-bit counter is not loaded or has reached terminal count, the INT pin will go high.
- **Bit 4:** This bit signifies that the TD0 shifter/buffer is reconfigured as a 32-Bit Pseudo Random Pattern Generator. If set, and MODE0 Bit 7 is set, the TDO shifter/buffer will stop TCK until a seed value has been written to all four of the 8-bit LFSR segments.
- **Bit 3:** This bit signifies that the TD1 shifter/buffer is reconfigured as a 16-Bit Serial Signature Compactor. If set, and MODE0 Bit 6 is set, the TDI shifter/buffer will cause TCK to stop until a seed value has been written to the two TDI registers.
- **Bit 2:** If this bit is set, a high value on FRZ will force TCK high (see [TCK Control](#) Section).
- **Bits 1 and 0:** These bits are used to control Test Loop-Back operations according to the following table.

MODE1 Bit 1	MODE1 Bit 0	Function
0	0	Normal Operation
0	1	Loop-Back TDO to TDI
1	0	Loop-Back TMS0 to TDI
1	1	Loop Back TMS1 to TDI

**Mode Register 2 (Mode2)**

Write:							
Bit 7	Bit 6	Bit 5	Bit 4	Bit 3	Bit 2	Bit 1	Bit 0
Not Used	Not Used	Not Used	Not Used	Continuous Update	Update Status	Reset	Single Step CNT32
Read:							
Bit 7	Bit 6	Bit 5	Bit 4	Bit 3	Bit 2	Bit 1	Bit 0
TDO Status	TDI Status	CNT32 Status	TMS0 Status	TMS1 Status	Continuous Update	Reset	Single Step CNT32

This register contains both mode and status bits. Bits 4–7 are status bits only. Bit 3 is a status bit during read operations and a mode bit during write operations. Bits 0–2 are mode bits only. Upon  $\overline{\text{RST}}$  low, or a synchronous reset, the value placed in MODE2 is 10111000 (Read mode). Latches used to update status bits 3–7 retain their last state upon  $\overline{\text{RST}}$  and are in an “unknown” state after power-up. To initialize the latches to a known state, they need to be updated using the Update Status bit (bit 2) or continuous update bit (bit 3).

- **Bit 7:** Set high if the TDO shifter/buffer is not full, i.e., one or both 8-bit TDO FIFOs are ready to be written to.
- **Bit 6:** Set high if the TDI shifter/buffer is not empty, i.e., one or both 8-bit TDI FIFOs are ready to be read from.
- **Bit 5:** Set high if the 32-bit counter has not been loaded, or has reached terminal count.
- **Bit 4:** Set high if the TMS0 shifter/buffer is not full, i.e., one or both 8-bit TMS0 FIFOs are ready to be written to.
- **Bit 3 (Read Cycle):**  
Set high if the TMS1 shifter/buffer is not full, i.e., one or both 8-bit TMS1 FIFOs are ready to be written to.
- **Bit 3 (Write Cycle):**  
If set, will cause all status bits to be continuously updated.
- **Bit 2 (Read Cycle):**  
Shows the state of the Continuous Update bit during read operations (Bit 3 during writes).
- **Bit 2 (Write Cycle):**  
If set, will cause a pulse to be issued internally that will update all status bits. This bit will be reset upon completion of the pulse. The state of this bit is not readable. It is reset upon  $\overline{RST}$  low.
- **Bit 1:** If set, will cause a synchronous reset of all functions except the parallel interface. The value of this bit will return to zero when the reset operation is complete.
- **Bit 0:** If set, will cause the 32-bit counter to count for one SCK cycle (no TCK cycle will be generated). The value of this bit will return to zero when the single step operation is complete.

### Programming Restrictions

Because certain mode bits enable shift operations for certain functions, these mode bits should *not* be changed when shift operations are in progress. The alignment of all registers during shift operations is controlled by a 3-bit counter in the TCK control block. Enabling or disabling a function in the middle of a shift operation may disrupt the logic necessary to keep all shifter/buffers byte-aligned.

For example, if the TDO shifter/buffer (already loaded) is enabled while the 3-bit counter value is 3, the shifter/buffer will only shift out only five bits of the first byte loaded.

The following bits should not be changed when shift operations are in progress, i.e., when TCK is enabled (see [TCK Control](#)).

- MODE0(7:3)
- MODE1(4:3)
- MODE2(0)

## PARALLEL PROCESSOR INTERFACE (PPI)

### Address Assignment

The following table defines which register is selected for access with the address lines, A(2:0).

A2	A1	A0	R/W	Function
0	0	0	0	TDO Shifter/Buffer
0	0	0	1	Counter Register 1
0	0	1	0	TDI Shifter/Buffer
0	0	1	1	TDI Shifter/Buffer
0	1	0	0	TMS0 Shifter/Buffer
0	1	0	1	Counter Register 2
0	1	1	0	TMS1 Shifter/Buffer
0	1	1	1	Counter Register 3
1	0	0	0	32-Bit Counter
1	0	0	1	Counter Register 0
1	0	1	0	MODE0
1	0	1	1	MODE0
1	1	0	0	MODE1
1	1	0	1	MODE1
1	1	1	0	MODE2
1	1	1	1	MODE2

### Timing Waveforms

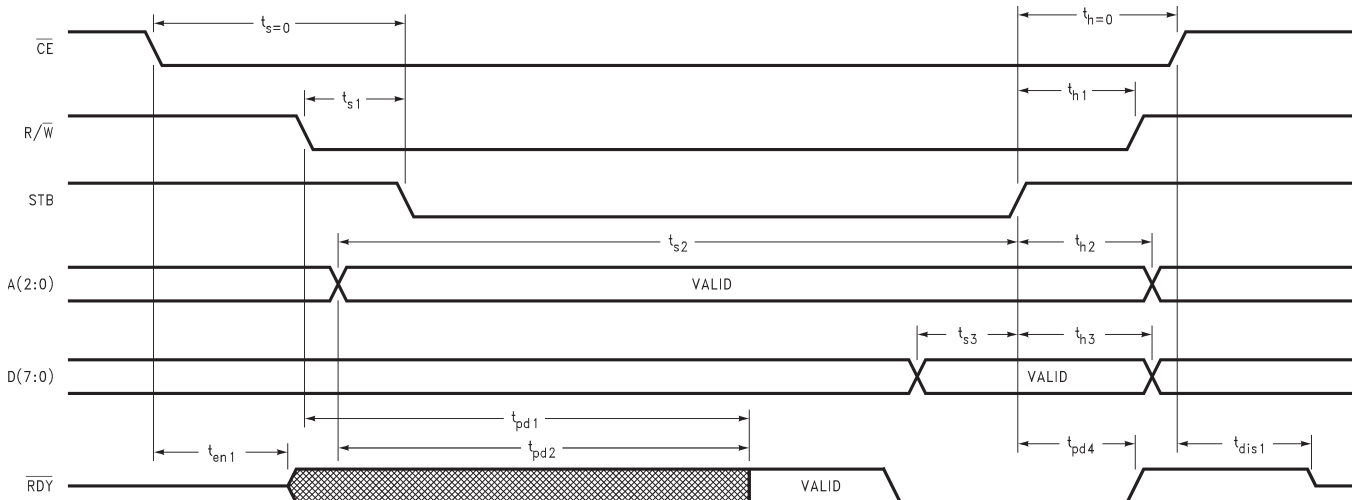
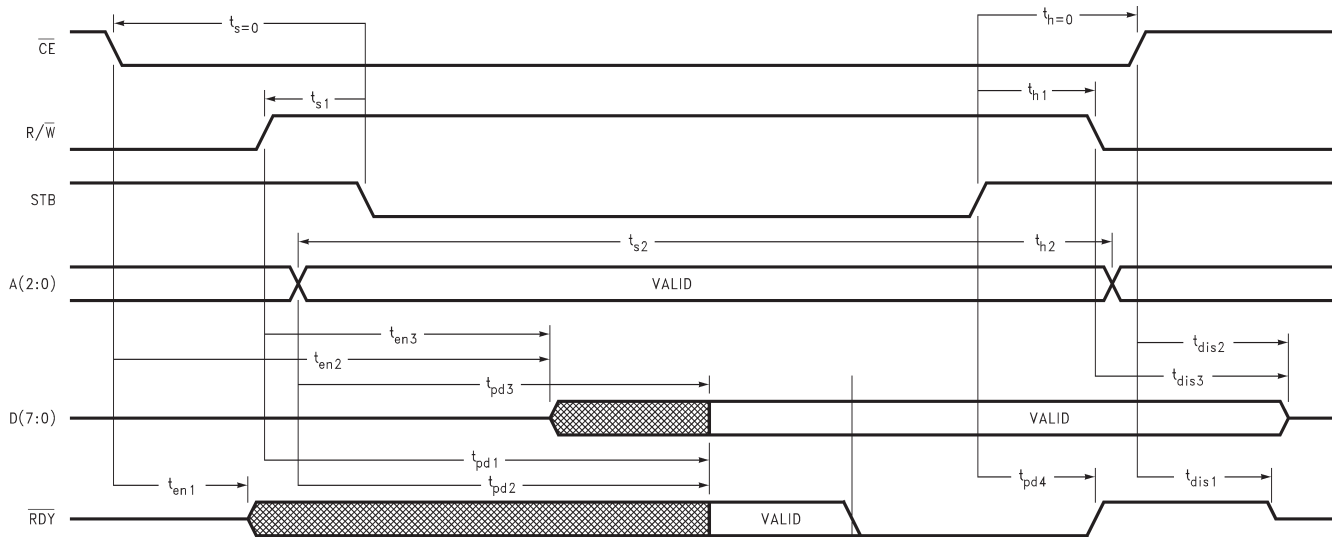

Figure 4. Write Cycle<sup>(1)</sup>

(1) Valid data is provided on the RDY line a  $t_{pd1}$  after  $R/\overline{W}$  is asserted low or a  $t_{pd2}$  after valid data is decoded on A2:0. The RDY line will remain high until the addressed register is ready to participate in the write operation. This condition only applies when writing to a shifter/buffer and is eliminated (i.e., RDY will go low immediately once valid) when using shifter/buffer status polling (discussed later in this datasheet).



**Figure 5. Read Cycle<sup>(2)</sup>**

- (2) Valid data will not appear on D7:0 (and RDY will remain high) until the addressed register is ready to participate in the read operation. When the addressed register becomes ready (i.e., a byte is available to be read), valid data will be placed on the D7:0 bus and the RDY pin will go low allowing the bus cycle to continue. This read cycle delay only applies when reading the TDI shifter/buffer and is eliminated when using shifter/buffer status poling.

## Timing Waveforms (Continued)

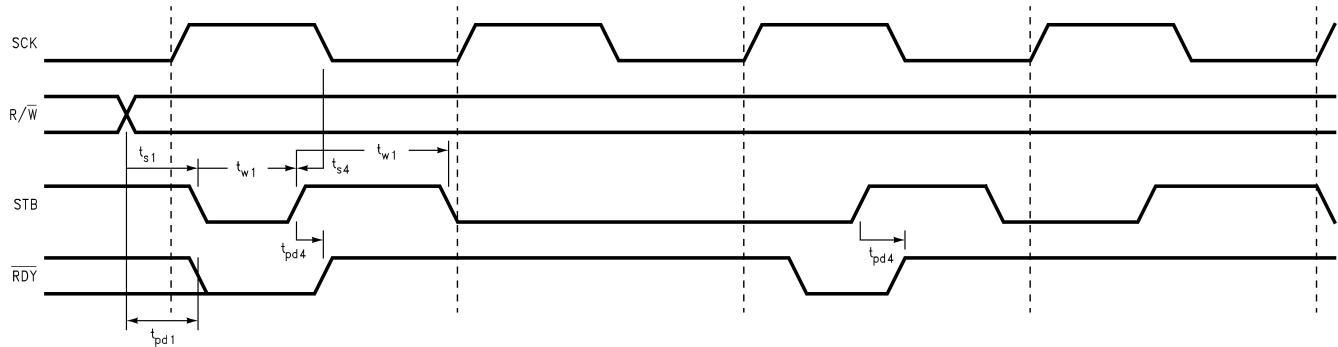

**Figure 6. Consecutive Read/Writes (best case timing)**

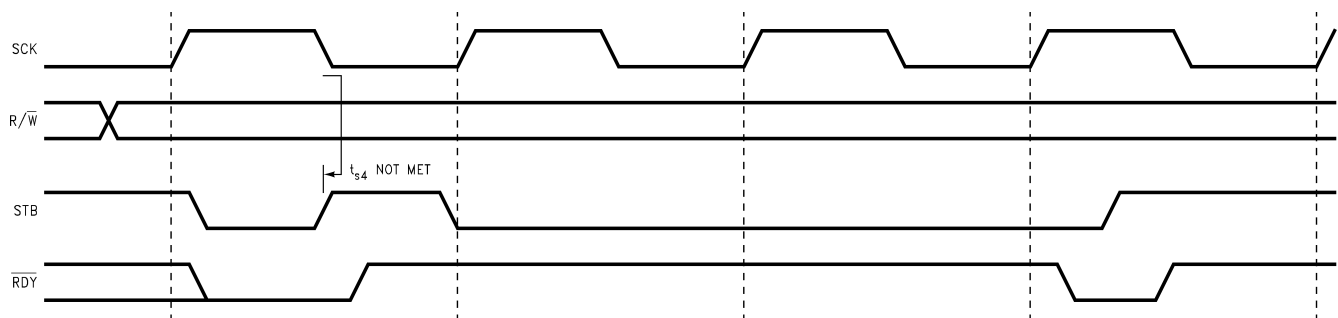

**Figure 7. Consecutive Read/Writes (worst case timing)**

- (1) [Figure 6](#) shows the best case bus cycle timing for SCK and STB during consecutive read or write cycles. The rising edge of strobe occurs a setup time,  $t_{s4}$  or before the falling edge of SCK. This allows the cycle to be completed within 1.5 clock SCK clock cycles. [Figure 7](#) shows the worst case bus cycle timing for SCK and STB during consecutive read or write cycles. The rising edge of strobe does not meet the  $t_{s4}$  requirement between STB and SCK. Therefore, the propagation of the internal PSC100 control and reset signals is delayed until the next falling edge of SCK. The bus cycle is then completed 1.5 SCK cycles later creating a total bus cycle time of 2.5 SCK cycles. If worst case timing is considered for bus cycle timing,  $t_{s4}$  is not a mandatory timing specification.



Timing Waveforms (Continued)

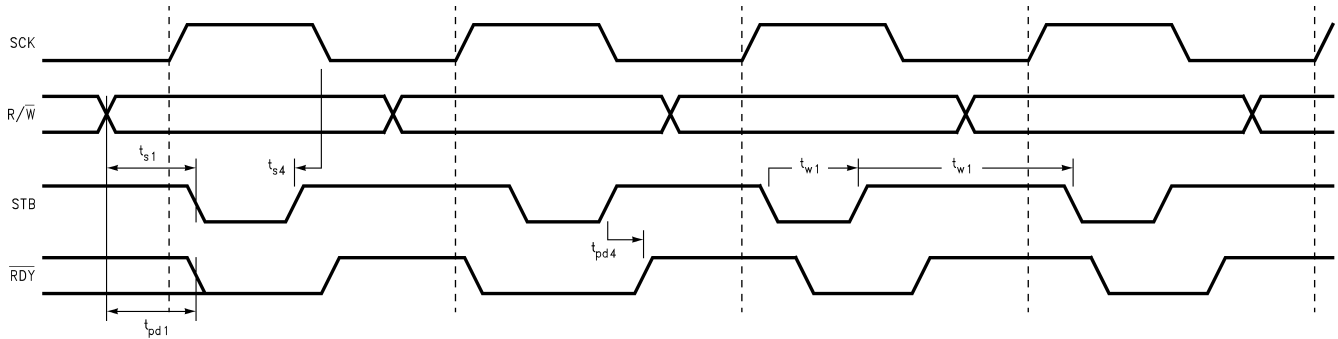

Figure 8. Read/Write or Write/Read (best case timing)

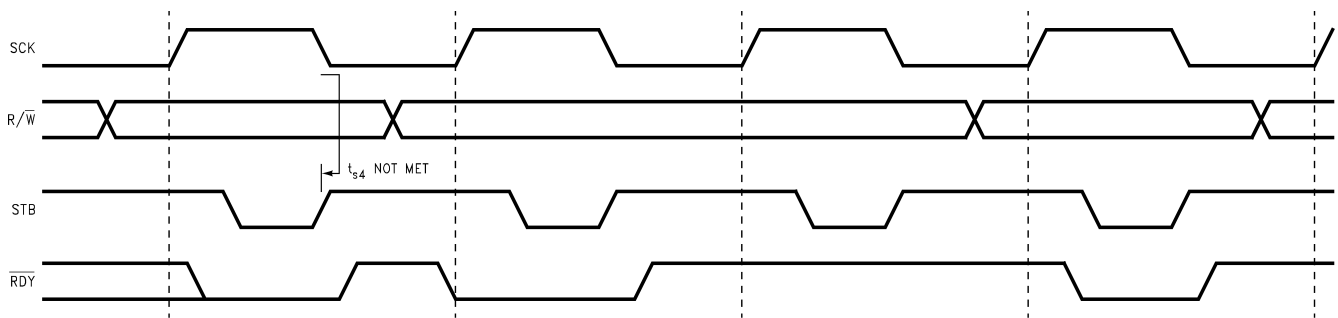

Figure 9. Read/Write or Write/Read (worst case timing)

- (1) This diagram shows the timing for a read followed by a write (or write followed by a read). Separate Read and Write data/address latches and control logic allow consecutive read/write or write/read operations to be overlapped (i.e., do not need to wait 2 or 3 SCK cycles between bus cycles). For the best case timing scenario (Figure 8: rising edge of STB to falling edge of SCK greater than  $t_{s4}$ ), a new bus cycle can be performed each SCK cycle. For the worst timing scenario (Figure 9: rising edge of STB to falling edge of SCK is less than  $t_{s4}$ ), a one SCK cycle delay must be included after each back to back read/write or write/read sequence.
- (2) Figure 6, Figure 7, Figure 8, and Figure 9 assume that the PSC100 register participating in the bus cycle is ready to accept/provide data. For bus cycles involving a PSC100 shifter/buffer(s), the ready status of a shifter/buffer can be checked using the status bits in Mode Register 2 prior to the start of the bus cycle. Polling is required when the RDY pin is not used to provide a processor “handshake”.

## Read And Write Cycles

A **Write cycle** (see [Figure 4](#)) is initiated by asserting  $\overline{CE}$  and  $R/\overline{W}$  low followed by a low on STB a set time later.  $\overline{CE}$  and STB are gated within the PSC100F and may be asserted concurrently (i.e., zero setup and hold time). The address is then asserted on A2:0 to indicate which internal address within the PSC100F will be written to by the processor. An address decoder within the PSC100F monitors the address lines for a valid PSC100F register address. Once a valid address has been decoded, the  $\overline{RDY}$  line becomes active (a propagation delay time later). The active  $\overline{RDY}$  line will go low immediately if the addressed register is ready to accept data. If the addressed register is not ready, the  $\overline{RDY}$  pin will remain high preventing the processor from completing the bus cycle. Once the register is ready to receive data (see [Table 2](#)), the  $\overline{RDY}$  pin will go low and processor can resume the write cycle. The processor then forces a high on STB (a wait time after  $\overline{RDY}$  goes low) which latches the address (A2:0) and data (D7:0) completing the bus cycle. The  $\overline{RDY}$  line is forced high a propagation delay later.

A **Read cycle** (see [Figure 5](#)) is initiated by asserting  $\overline{CE}$  low and  $R/\overline{W}$  high followed by a low on STB a set time later.  $\overline{CE}$  and STB are gated within the PSC100F and may be asserted concurrently (i.e., zero setup and hold time). The address bits (A2:0) are then asserted to indicate which internal address within the PSC100F will be read by the processor. An address decoder within the PSC100F monitors the address lines for a valid PSC100F register address. Once a valid address has been decoded and if the addressed PSC100F register is ready to be read (see [Table 2](#)), valid data is placed on the Data lines (D7:0) a propagation delay later and the ready line is asserted low. If the addressed register is not ready (e.g., the TDI shifter/buffer is empty), the ready line will remain high and hold the bus cycle until the register contains valid data.  $\overline{RDY}$  will then go low allowing the read cycle to continue. With the high to low edge on  $\overline{RDY}$  line, the processor can successfully read the valid data. However, the bus cycle is not completed within the PSC100F until the rising edge on STB which resets the PSC100F read logic (required prior to the start of the next read cycle).

**Important note concerning the use of  $\overline{RDY}$  :** The  $\overline{RDY}$  signal provides a useful “handshake” between the PSC100F and the processor. However, care must be taken when using the PSC100F  $\overline{RDY}$  signal to prevent a large (or indefinite) number of processor generated wait states. For example, if the TDO shifter/buffer is not enabled for shift operations and the processor writes to the TDO shifter/buffer address 3 times, the two registers which make up the TDO shifter/buffer will accept the first two bytes of data, but since the data is not shifting out, the 3rd byte will be held off by the  $\overline{RDY}$  signal indefinitely. An equally severe problem could result with a finite number of wait states if the application uses dynamic memories. Holding the local bus with the PSC100F  $\overline{RDY}$  line long enough to violate a DRAM refresh time will result in lost data within the dynamic memory.

**Writing and Reading without the use of  $\overline{RDY}$  :** With use of worst case PSC100F timing, Write and Read cycles can be successfully completed without the use of the  $\overline{RDY}$  signal. All read and write cycles will complete within 2.5 SCK cycles (worst case). Therefore, by assuring at least 2.5 cycles occur after the rising edge of STB, bus cycles can be completed without using the  $\overline{RDY}$  “handshake”. The critical timing relationship within the PSC100F for write and read operation is between the rising edge of STB and the falling edge of SCK. The rising edge of strobe latches the address/data and also generates the internal signals required to complete read/write within the PSC100F (including a signal which resets the read/write logic and releases the  $\overline{RDY}$  line). The propagation of these internal signals is initiated on the first falling edge of SCK after the STB pin is asserted high. If the rising edge on STB occurs an internal setup time ( $t_{s4}$ ) or greater before the falling edge of SCK, the bus cycle can be completed within 1.5 SCK cycles (see [Figure 6](#)). However, if the internal setup time is not met, the propagation of internal control/reset signals is delayed until the next falling edge of SCK (1 SCK cycle later) which effectively completes the read/write operation and reset the logic for the next bus cycle within 2.5 cycles (see [Figure 7](#)). Synchronizing the rising edge of STB with the falling edge of SCK to assure that  $t_{s4}$  is met provides the maximum performance for a read/write operation. However, the asynchronous interface can be used effectively with software delays, hardware delays or programmed wait states (to assure 2.5 SCK cycles are completed) to avoid the need for synchronization.

**Consecutive Reads and Writes:** Separate control logic and data/address latches are used for a read and write operation within the PSC100F. This allows a write to occur after a read (or conversely, a read to occur after a write) prior to the 1.5/2.5 SCK clock cycle requirements described above. The timing for a read (or write) followed by a write (or read) is shown in [Figure 7](#) and [Figure 8](#).

## Synchronization

Writes and reads can be synchronized by using any of three methods: polling, interrupts, or wait state generation:

- Status bits may be polled to see if a register is ready to be written to or read from. To stabilize the status bits for read operations, the Update Status bit must be set in MODE2 to latch the status.

### NOTE

The status bits only provide the state of the shifter/buffers and do not indicate that an internal write or read is complete. Therefore, for applications not using the  $\overline{\text{RDY}}$  signal to monitor the internal write/read status, timing must be controlled to assure that at least 2.5 SCK cycles are completed between consecutive read or consecutive write cycles.

- Any of three different events can be used to generate interrupts by forcing the INT pin high, see [Table 1](#).
- The  $\overline{\text{RDY}}$  pin can be used to hold off the host until the addressed register is ready to be accessed. As described above, this pin can also be used to hold off additional reads/writes until the synchronizer has recovered from the previous read/write.  $\overline{\text{RDY}} = 0$  signifies that the 'PSC100F is ready to complete the current PPI cycle. The logic that determines the state of  $\overline{\text{RDY}}$  is summarized in [Table 2](#).

Reading from CNT32 can be synchronized for testing by using the Single Step Counter mode bit.

**Table 1. Interrupt Logic**

MODE1(7) = 1 and TDO Shifter/Buffer Not Full	MODE1(6) = 1 and TDI Shifter/Buffer Not Empty	MODE1(5) = 1 and CNT32 Not Loaded, or at Terminal Count	INT <sup>(1)</sup>
1	X	X	1
X	1	X	1
X	X	1	1
0	0	0	0

- (1) Interrupts are generated using the INT pin. Three events trigger INT high. Each event has its own mode bit associated with it for masking or enabling these interrupts.

**Table 2. Ready State Logic**

R/W	Write Synchronizer Busy	TDO Shifter/Buffer Full and A(2:0) = 0	TMS0 Shifter/Buffer Full and A(2:0) = 2	TMS1 Shifter/Buffer Full and A(2:0) = 3	Read Synchronizer Busy	TDI Shifter/Buffer Empty and A(2:0) = 1	$\overline{\text{RDY}}$
0	1	X	X	X	X	X	1
0	X	1	X	X	X	X	1
0	X	X	1	X	X	X	1
0	X	X	X	1	X	X	1
0	0	0	0	0	X	X	0
1	X	X	X	X	1	X	1
1	X	X	X	X	X	1	1
1	X	X	X	X	0	0	0

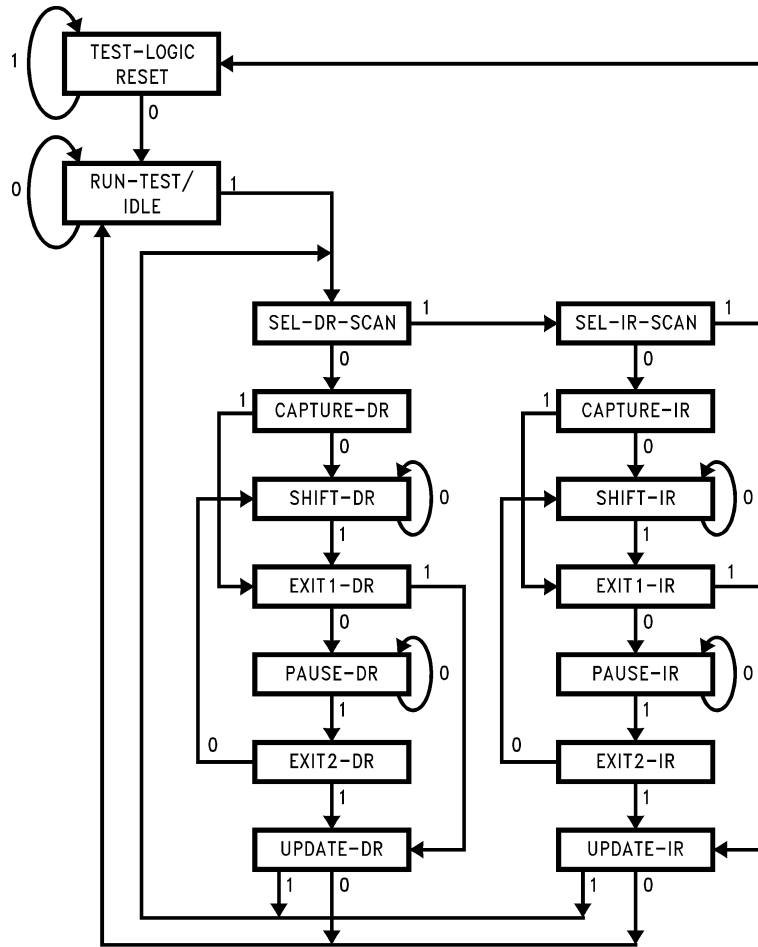

Figure 10. 1149.1 (JTAG) TAP Controller State Diagram

## SERIAL SCAN INTERFACE (SSI)

### TCK Control

TCK CONTROL is the central control block that enables or disables shift operations and provides byte alignment for the shifter/buffers. The state of all shifter/buffers and the 32-bit counter (CNT32) is evaluated here and TCK is stopped and started. A clock enable circuit allows the “TCK enable” signal to change only when SCK is low; therefore, TCK always stops low. TCK does not toggle (remains low) under the following conditions:

- TDO Shifter/Buffer is enabled and empty.
- TDO Shifter/Buffer is enabled in PRPG mode and is not fully loaded.
- TDI Shifter/Buffer is enabled and full.
- TDI Shifter/Buffer is enabled in SSC mode but is not fully loaded with an initial value.
- TMS0 Shifter/Buffer is enabled and empty.
- TMS1 Shifter/Buffer is enabled and empty.
- CNT32 is enabled but not loaded.
- CNT32 is enabled and has reached terminal count.

Also included within the TCK control block in CNT3, a 3-bit count up counter. CNT3 is included to maintain byte alignment within the shifter/buffers by providing a signal to toggle between the two 8-bit FIFOs which comprise the shifter/buffer. The toggling operation occurs, in an enabled shifter/buffer, each time CNT3 counts 8 TCK cycles or when CNT32 reaches terminal count. The CNT3 is reset to 0 when CNT32 reaches terminal count or after a PSC100 reset condition.

**FREEZE MODE.** This mode is included in the TCK control block to support the 1149.1 SAMPLE operation. The intent of the SAMPLE instruction is to allow device input and output levels to be observed during normal system operation. Data is latched (or “sampled”) into the boundary scan registers when the TAP controller (see [Figure 10](#) on previous page) transitions from the Capture-DR state to the Shift-DR state (if SAMPLE/ PRELOAD is the active instruction). Synchronizing this “transition” (rising edge of TCK with TMS at logic low) with a known system state is imperative to an accurate pass/fail assessment. The Freeze Mode provides a means of asynchronously creating the TCK pulse via an external PSC100 pin. When the Freeze Pin Enable bit (bit 2 in Mode Register 1) is set, a logic high on the PSC100 FRZ input pin will cause TCK to go high. Once the transition is complete, the Freeze Mode can be removed (i.e. Freeze Pin Enable bit returned to logic 0 or Freeze pin forced low) and the sampled data can be shifted out/evaluated using the “standard” PSC100 protocol. [Figure 11](#) illustrates the logic implementation of the Freeze feature. It should be noted that Freeze mode is simply gated with the TCK output and does not disable shift operations within the shifter/buffers or disable CNT32. Therefore, no shifting or TCK counting using CNT32 should be performed when Freeze mode is enabled.

The “standard” mode of TCK control uses CNT32 in conjunction with the status registers to start and stop TCK. For this mode, CNT32 is enabled and loaded with the number of TCK cycles required to shift the desired bits to/from the scan chain. The shifter/buffer(s) participating in the shift operation is enabled and provides the necessary full/empty status to stop TCK for processor writes/reads. This mode of TCK control provides a systematic protocol for managing PSC100 operations (specifically, handling partial bytes). Another option for TCK control relies solely on the status of the shifter/buffers (i.e., CNT32 is disabled) to start and stop TCK. This option eliminates the time required to load CNT32, but makes management of partial bytes more cumbersome.

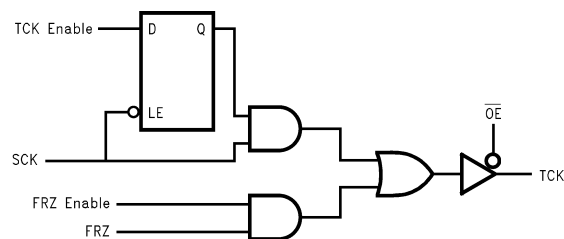
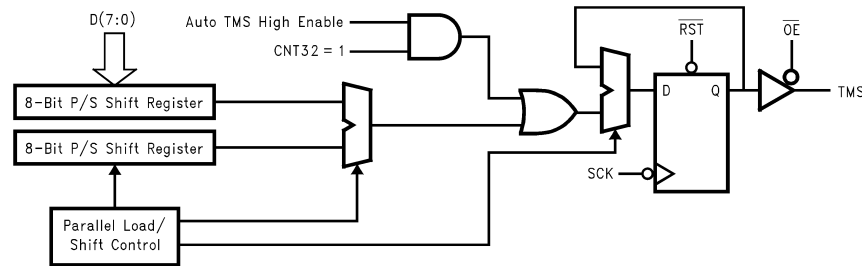

Figure 11. TCK Logic



**Figure 12. TMS Shifter/Buffer Block Diagram**

### TMS(1:0) Shifter/Buffers

The TMS Shifter/Buffer block diagram is shown in [Figure 12](#). These two blocks take parallel data and serialize it for shift operations through the serial port pins TMS0 and TMS1.

Double-buffering is achieved by configuring the shifter/buffer as a 2 x 8 FIFO. Write and shift operations are controlled by a local state machine that accepts stimulus from the PPI, Mode Registers, CNT32 and TCK Control section. The TMS outputs always change on the falling edge of SCK. The order of shifting is least significant bit first. TMS(1:0) are forced high upon RST low. TMS(1:0) are Tri-States when OE is high.

Write operations are completed if the shifter/buffer is not full (independent of whether shifter/buffer is enabled or disabled). Otherwise they are ignored. Shifting occurs when the following conditions are all true:

- TMS is enabled with its respective mode bit.
- TMS shifter/buffer is not empty.
- TCK is enabled according to the logic in TCK Control.

When shift operations are not enabled, the TMS output retains its last state. During long shift sequences, the TMS shifter/buffer can be disabled and held static so that shift operations are concentrated only on TDI and TDO. The TMS output also retains its last state when Test Loop-Back operations are in progress.

Local select circuitry is used to toggle back and forth between the two registers of the “FIFO” when shifting. At any given time, one register is selected for shift operations. The other holds its previous state or can accept new parallel data. Shift register selection changes due to the following two events:

- CNT3 in TCK Control signals that 8 bits have been shifted. This event is used for basic toggling between each of the two shift registers.
- CNT32 enabled and at terminal count. This event is used to account for scan lengths which are not multiples of eight. When shift register selection changes due to this signal, any data remaining in the shift register is unused.

**AUTO TMS HIGH MODE** . This feature is included in the TMS shifter/buffer block to improve the efficiency of the PSC100 in supporting shift operations within the 1149.1 devices connected to the SSI. Shifting data and instructions into 1149.1 compliant devices requires that their TAP controllers be sequenced to the Shift-DR or Shift-IR states (see [Figure 10](#)). Once in this state, shifting occurs by holding TMS low and clocking TCK. The last bit is shifted when the TAP controller transitions to the EXIT1 state. This transition requires a logic 1 on TMS. The Auto TMS High feature, enabled by setting bit 1 of Mode Register 0, automatically creates a logic 1 on the TMS lines of the PSC100 when CNT32 = 1. Consequently, the last bit is shifted out without having to load specific TMS data into the shifter/buffer.

#### NOTE

Auto TMS High mode creates a logic 1 on both TMS lines (i.e., TMS0 and TMS1). Therefore, when using the Auto TMS High feature, all 1149.1 devices connected to the TMS line not participating in the current JTAG test operations should be placed in the Test-Logic-Reset TAP controller state to prevent inadvertent TAP controller transitions.

## TDO Shifter/Buffer

The TDO Shifter/Buffer block diagram is shown in Figure 13. This block takes parallel data and serializes it for shift operations through the serial port pin TDO. During normal shift modes, double-buffering is achieved by configuring the shifter/buffer as a 2 x 8 FIFO. This block can also be configured as a 32-bit Pseudo Random Pattern Generator (PRPG) with two additional 8-bit parallel-to-serial shift registers. Write and shift operations are controlled by a local state machine that accepts stimulus from the PPI, Mode Registers, CNT32, and the TCK Control section. The TDO output always changes on the falling edge of SCK. The order of shifting is least significant bit first. TDO is forced high upon RST low. TDO is Tri-States when OE is high.

Write operations are completed if the shifter/buffer is not full (independent of whether shifter/buffer is enabled or disabled). Otherwise they are ignored.

Shifting occurs when the following conditions are all true:

- TDO is enabled with its respective mode bit.
- TDO shifter/buffer is not empty.
- TCK is enabled according to the logic in TCK Control.

When shift operations are not enabled, the TDO output retains its last state. The TDO output also retains its last state when Test Loop-Back operations are in progress.

Local select circuitry is used to toggle back and forth between the two registers of the “FIFO” when shifting. At any given time, one register is selected for shift operations. The other holds its previous state or can accept new parallel data. Shift register selection changes due to the following two events:

- CNT3 in TCK Control signals that 8 bits have been shifted. This event is used for basic toggling between each of the two shift registers.
- CNT32 enabled and at terminal count. This event is used to account for scan lengths which are not multiples of eight. When shift register selection changes due to this signal, any data remaining in the shift register is unused.

**PRPG MODE** . By setting MODE1(4), the TDO Shifter/Buffer is reconfigured as a 32-bit PRPG (Pseudo Random Pattern Generator) using the primitive polynomial:

$$F(X) = X^{32} + X^{22} + X^2 + X + 1 \quad (1)$$

The PSC100 was developed to support both 1149.1 and non-1149.1 serial test methodologies. Since 1149.1 compliant devices include boundary scan registers on control pins (i.e. OE), which must remain fixed during boundary scan interconnect testing, generating pseudo-random patterns with PRPG mode provides limited usefulness for boundary scan test operations. PRPG mode may provide usefulness in other serial test or non-test related implementations which do not require fixed bits in the serial chain.

Figure 14 shows a block diagram of the Linear Feedback Shift Register hookup.

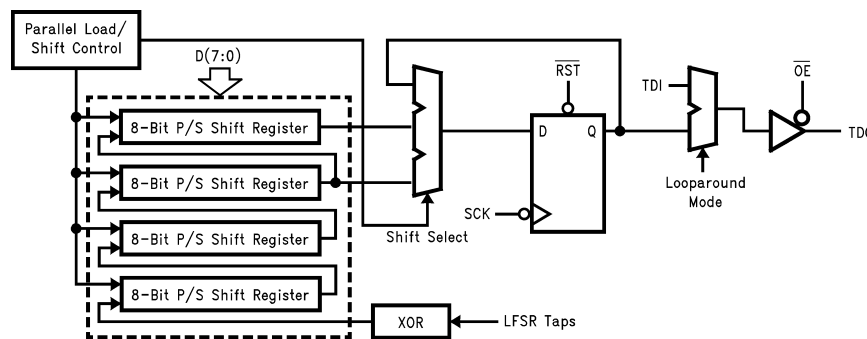
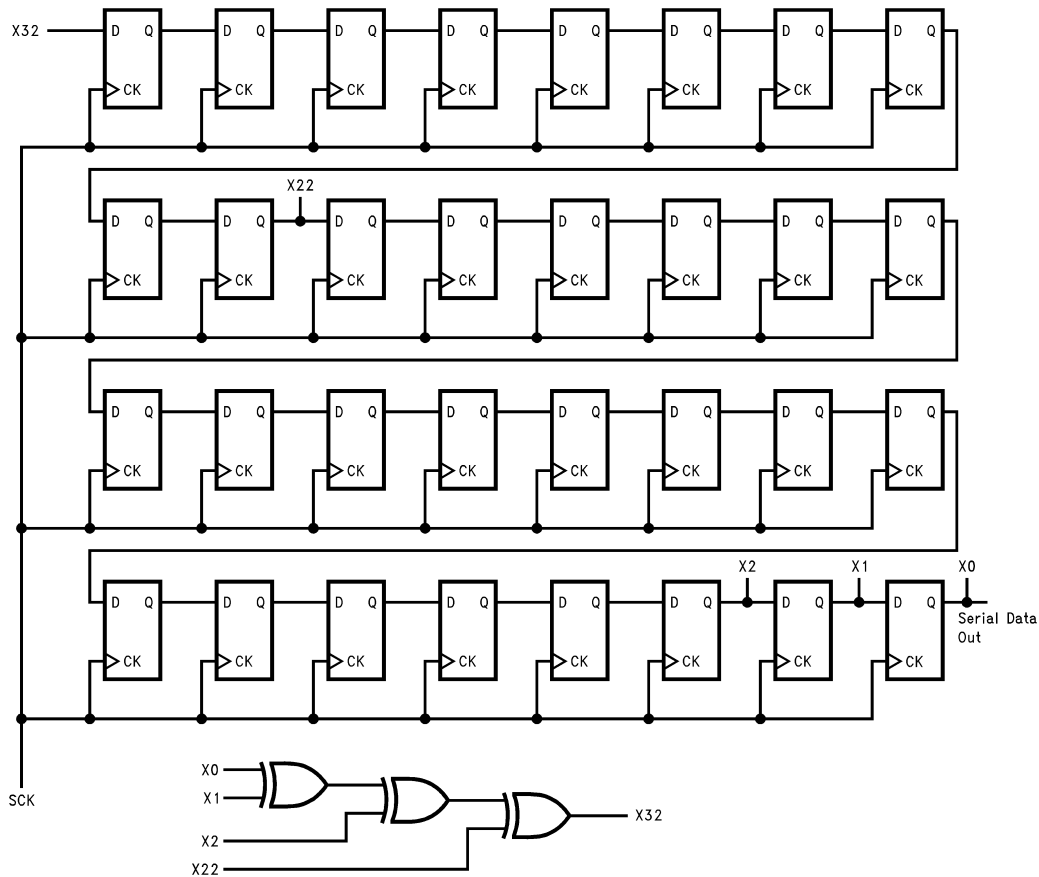

Figure 13. TDO Shifter/Buffer Block Diagram Register Hookup



**Figure 14. TDO PRPG Block Diagram**

The PRPG is loaded by four PPI writes to the TDO address. When the PRPG enable bit is set, a pulse is issued internally that initializes the local parallel load logic such that the PRPG is loaded sequentially, least significant byte first, most significant byte last. When in PRPG mode, writes can be completed at any time; however, shift operations will be disabled until the PRPG is fully loaded.

**LOOP AROUND MODE** . This mode, enabled by setting bit 0 in Mode Register 0, will cause data appearing at the TDI input to be placed directly back on the TDO output. This feature can be used for read-only scan operations where data is shifted into TDI while returning the scan chain to its previous state when shifting is completed. It can also be used to bypass PSC100 devices connected within a boundary scan chain (i.e., a PSC100 located within a chain, but not providing the JTAG TAP data). Loop around has limited usefulness in most boundary scan applications since, typically, data in the scan chain is shifted out and evaluated as new data is shifted into the chain for the next test.

**WRITING A PARTIAL BYTE TO THE TMS0, TMS1 OR TDO SHIFTER/BUFFER.** Since the TMS0, TMS1 and TDO shifter/buffers shift out least significant bit first, the valid (meaningful) bits within a partial byte (i.e., byte containing <8 valid bits to be shifted to the scan chain) must be stored and written into the shifter/buffer as the least significant bits. This will assure that the desired bits will be accurately shifted to the boundary scan chain. For example, moving the TAP controllers within the boundary scan chain connected to TMS0 from the Pause-DR state to the Run-Test/Idle state requires a 3-bit (110) sequence on TMS0. To provide correct 3-bit sequence on TMS0, the partial byte would be written to the TMS0 shifter/buffer as:

MSB										LSB	
	x	x	x	x	x	0	1	1		→	TMS0



A subsequent enable and load of CNT32 with decimal 3 and enable of the TMS0 shifter/buffer will initialize the shift operation. Terminal count on CNT32 will complete the shift operation. Since terminal count on CNT32 will cause the register selection to change within the shifter/buffer, the values labeled as “x” will not be used and are treated as “don’t cares”.

### TDI Shifter/Buffer

The TDI Shifter/Buffer block diagram is shown in [Figure 15](#). This block shifts in serial data from the TDI port and puts it in parallel form for read operations at the PPI. During normal shift modes, double-buffering is achieved by configuring the shifter/buffer as a 2 x 8 FIFO. This block can also be configured as a 16-bit Serial Signature Compactor (SSC). Write, read, and shift operations are controlled by a local state machine that accepts stimulus from the PPI, Mode Registers, CNT32 and the TCK Control section. The TDI input always shifts in data on the rising edge of SCK. The order of shifting is least significant bit first. The TDI input includes a pull-up resistor to force a logic 1 when the test data signal returning from the scan chain is floating.

Read operations are completed if the shifter/buffer is not empty and SSC mode is not enabled. Otherwise they are ignored. Write operations are only possible while in SSC mode. Otherwise they are ignored.

Shifting occurs when the following conditions are all true:

- TDI is enabled with its respective mode bit.
- TDI shifter/buffer is not full.
- TCK is enabled according to the logic in TCK Control.

Local select circuitry is used to toggle back and forth between the two registers of the “FIFO” when shifting. At any given time, one register is selected for shift operations. The other holds its previous state or can accept new serial data. Shift register selection changes due to the following two events:

- CNT3 in TCK Control signals that 8 bits have been shifted in. This event is used for basic toggling between each of the two shift registers.
- CNT32 enabled and at terminal count. This event is used to account for scan lengths which are not multiples of eight. When shift register selection changes due to this signal, a partial byte (i.e., byte with < eight valid data bits shifted from the scan chain) will exist in the corresponding shift register. The embedded test software functions written to support the evaluation of data read from the TDI shifter/buffer must consider bit placement when reading and evaluating a partial byte.

**READING A PARTIAL BYTE FROM THE TDI SHIFTER/BUFFER.** Data is shifted from the scan chain into each TDI register from most significant bit to least significant bit. Consequently, the valid (i.e., meaningful) bits in a partial byte shifted into a TDI register will reside in the upper significant bit locations. For example, if a scan operation involves shifting and evaluating 53 bits returning to TDI, TDI shifter/buffer must be read 7 times (i.e., 6 full bytes plus a partial byte containing 5 meaningful bits). If the last 5 bits shifted back to the TDI shifter/buffer are 11010, then upon completion of the shift operation (i.e., terminal count on CNT32), the shift register within the TDI shifter/buffer will contain the following partial byte:

	MSB					LSB		
TDI →	0	1	0	1	1	x	x	x

Following a read of a partial byte, the embedded test software must adjust the position of the valid bits read from the TDI shifter/buffer or the position of the expected data to assure that an accurate comparison is made (and the non-meaningful bits are masked).

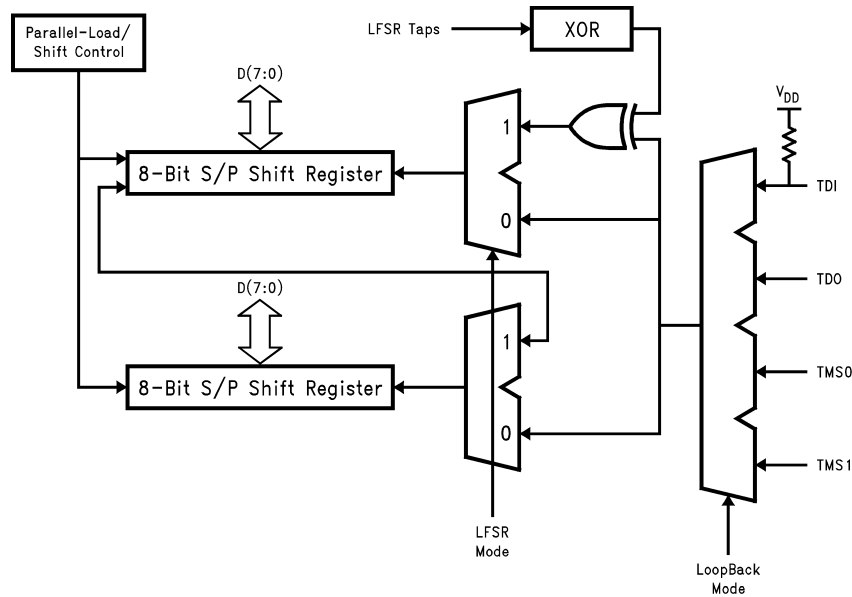

Figure 15. TDI Shifter/Buffer Block Diagram

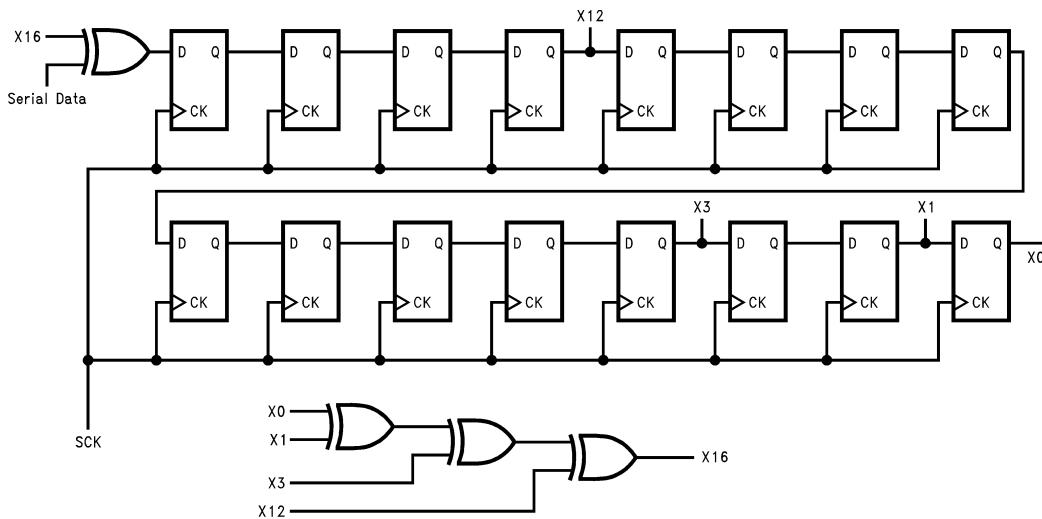

Figure 16. TDI SSC Block Diagram

**SSC MODE.** By setting MODE1(3), the TDI Shifter/Buffer is reconfigured as a 16-bit SSC (Serial Signature Compactor) using the primitive polynomial:

$$F(X) = X^{16} + X^{12} + X^3 + X + 1 \quad (2)$$

Within a chain of 1149.1 compliant devices, there are typically one or more input pins which are driven by uncontrolled signals (i.e., signals which are not driven to known logic levels during a boundary scan CAPTURE operation). These signals are masked during the evaluation of data returning from the scan chain. The SSC within the PSC100 does not provide masking capabilities and, therefore, provides limited usefulness for boundary scan test operations. SSC mode may provide usefulness in other serial test or non-test related implementations which contain predictable data returning into the TDI shifter/buffer.

Figure 16 shows a block diagram of the Linear Feedback Shift Register hookup.

The SSC is loaded by two PPI writes to the TDI address. When the SSC enable bit is set, a pulse is issued internally that initializes the local parallel load logic such that the SSC is loaded sequentially, most significant byte first, least significant byte last. When in SSC mode, writes can be completed at any time; however, shift operations will be disabled until the SSC is fully loaded. PPI reads from TDI are ignored while in SSC mode.

Upon leaving SSC mode an internal pulse causes the TDI shifter/buffer to be full. Also, local read select logic is initialized such that the signature is read most-significant byte first.

**TEST LOOP-BACK MODES.** This feature provides a means for testing 'PSC100 functionality by looping data appearing at the output of an outgoing shifter/buffer (i.e., TMS0, TMS1 or TDO) back to the input of the TDI shifter/buffer. The loop back function is accomplished with a simple multiplexer (see [Figure 15](#)) whose path selection is determined by setting the mode bits in MODE1(1:0). Loop back does not disable TCK or prevent shifting of data in the shifter/buffers to the scan chain(s) connected to the PSC100. Therefore, the state and operation of the TAP controllers within the scan chain(s) must be considered when developing Loop-Back test vectors to prevent undesired shifting of data or TAP controller transitions within the scan chain.

### 32-Bit Counter (CNT32)

CNT32 is a 32-bit, count-down binary counter arranged in four 8-bit segments. CNT32 can be loaded independent of its enable/disable status. Loading requires four consecutive writes to its address (least significant byte first). These four writes must *not* be interleaved with writes to any other address or the CNT32 write control logic will be re-initialized. This re-initialization will result in a partially filled counter with an undesired *value*. CNT32 is reset each time the counter hits terminal count or by asserting the  $\overline{RST}$  pin. A synchronous reset condition (setting Mode2(1)) does not reset the counter and a new value must be written to CNT32 to provide the desired number of TCK cycles.

**SINGLE STEP MODE:** All four 8-bit registers are readable for testability; however, there are no update latches similar to the ones used for the status bits. To stabilize the counter for read operations during on-board test, the Single Step Mode has been added. This allows the user to place CNT32 in any state and then count for one SCK cycle (TCK will not toggle when in singled step mode). The result can then be read from the PPI. The counter can be tested by loading it with values at its boundary conditions, and then clocking for one cycle to see the results. For example, the counter could be loaded with the value:

```
00000001 00000000 00000000 00000000
```

The next step is to set the Single Step Mode bit so that the counter counts down to the next state and stops. The next value is:

```
00000000 11111111 11111111 11111111
```

Four read cycles using the PPI will reveal the results of the test.

---

#### NOTE

CNT32 will not wrap from terminal count (i.e., 00000000h decremented by 1 will remain unchanged and will not wrap to FFFFFFFFh). Therefore, CNT32 should be loaded with a non-zero value prior to a Single Step Mode Operation.

---

## Timing Waveforms

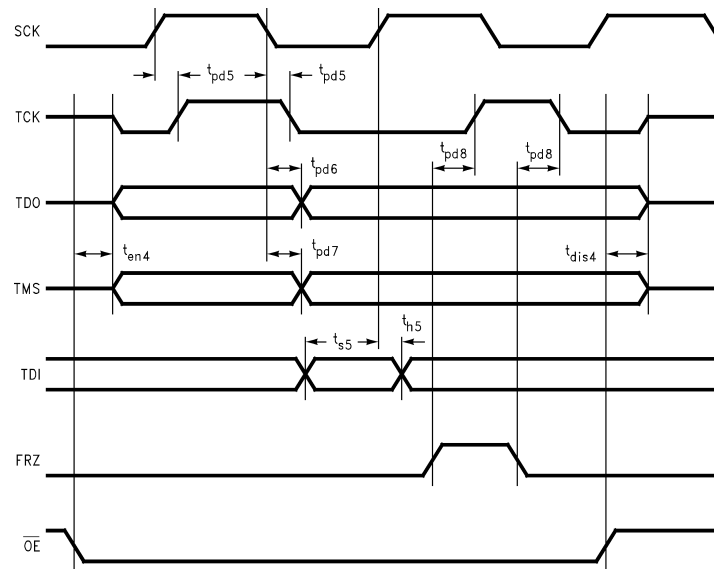

**Figure 17. Serial Scan Interface Timing**

## Embedded Test Software Support

A SCANPSC100 device driver is provided by Texas Instruments to supply functions for performing write, read and shift operations. Texas Instruments also offers a suite of software tools (called SCAN EASE) which enables ATPG or custom generated test vectors to be embedded, applied and evaluated within an IEEE 1149.1 compatible system. SCAN EASE is written to run on a wide range of processor and memory architectures. SCAN EASE includes the source code (ANSI C) and is modular to allow user modification based on application specific needs.



These devices have limited built-in ESD protection. The leads should be shorted together or the device placed in conductive foam during storage or handling to prevent electrostatic damage to the MOS gates.

**ABSOLUTE MAXIMUM RATINGS** <sup>(1)(2)</sup>

Supply Voltage ( $V_{CC}$ )		-0.5V to +7.0V
DC Input Diode Current ( $I_{IK}$ )	$V_I = -0.5V$	-20 mA
	$V_I = V_{CC} + 0.5V$	+20 mA
DC Input Voltage ( $V_I$ )		-0.5V to $V_{CC} + 0.5V$
DC Output Diode Current ( $I_{OK}$ )	$V_O = -0.5V$	-20 mA
	$V_O = V_{CC} + 0.5V$	+20 mA
DC Output Voltage ( $V_O$ )		-0.5V to $V_{CC} + 0.5V$
DC Output Source/Sink Current ( $I_O$ )		±50 mA
DC $V_{CC}$ or Ground Current (Per Output Pin)		±50 mA
DC Latchup Source or Sink Current		±300 mA
Junction Temperature	CDIP/CLGA	+175°C
Storage Temperature		-65°C to +150°C
ESD Last Passing Voltage (Min)		4000V

- (1) Absolute Maximum Ratings are those values beyond which damage to the device may occur. The databook specifications should be met, without exception, to ensure that the system design is reliable over its power supply, temperature, and output/input loading variables. Texas Instruments does not recommend operation of SCAN outside of recommended operation conditions.
- (2) If Military/Aerospace specified devices are required, please contact the Texas Instruments Sales Office/Distributors for availability and specifications.

**RECOMMENDED OPERATING CONDITIONS**

Supply Voltage ( $V_{CC}$ )		PSC100F	4.5V to 5.5V
Input Voltage ( $V_I$ )			0V to $V_{CC}$
Output Voltage ( $V_O$ )			0V to $V_{CC}$
Operating Temperature ( $T_A$ )		Military	-55°C to +125°C
Minimum Input Edge Rate dV/dt	SCAN "F" Series Devices	$V_{IN}$ from 0.8V to 2.0V $V_{CC}$ @ 4.5V, 5.5V	125 mV/ns

**DC ELECTRICAL CHARACTERISTICS**

Symbol	Parameter <sup>(1)</sup>	$V_{CC}$ (V)	Military	Units	Conditions
			$T_A = -55^\circ\text{C}$ to $+125^\circ\text{C}$		
			Specified Limits		
$V_{IH}$	Minimum High Input Voltage	4.5	2.0	V	$V_{OUT} = 0.1V$ or $V_{CC} - 0.1V$
		5.5	2.0		
$V_{IL}$	Maximum Low Input Voltage	4.5	0.8	V	$V_{OUT} = 0.1V$ or $V_{CC} - 0.1V$
		5.5	0.8		
$V_{OH}$	Minimum High Output Voltage	4.5	4.4	V	$I_{OUT} = -50 \mu\text{A}$
		5.5	5.4		
		4.5	3.70	V	$V_{IN} = V_{IL}$ or $V_{IH}$ $I_{OH} = -24 \text{ mA}$ All Outputs Loaded
		5.5	4.70		
$V_{OL}$	Maximum Low Output Voltage	4.5	0.1	V	$I_{OUT} = -50 \mu\text{A}$
		5.5	0.1		
		4.5	0.50	V	$V_{IN} = V_{IL}$ or $V_{IH}$ $I_{OL} = 24 \text{ mA}$ All Outputs Loaded
		5.5	0.50		

- (1) This parameter is not directly testable, but is derived for use in Total Power Supply calculations.

**DC ELECTRICAL CHARACTERISTICS (continued)**

Symbol	Parameter <sup>(1)</sup>	V <sub>CC</sub> (V)	Military		Units	Conditions
			T <sub>A</sub> = -55°C to +125°C			
			Specified Limits			
I <sub>IN</sub>	Maximum Input Leakage Current	5.5	±1.0		μA	V <sub>IN</sub> = V <sub>CC</sub> for TDI, $\overline{OE}$ V <sub>IN</sub> = V <sub>CC</sub> , GND for All Others
I <sub>ILR</sub>	Maximum Input Leakage Current	5.5	-385		μA	V <sub>IN</sub> = GND for TDI, $\overline{OE}$ Only
I <sub>OLD</sub>	Minimum Dynamic Output Current	5.5	50		mA	V <sub>OLD</sub> = 1.65V Max Maximum Test Duration = 2.0 ms, One Output Loaded at a Time
I <sub>OHD</sub>	Minimum Dynamic Output Current	5.5	-50		mA	V <sub>OHD</sub> = 3.85V Min Maximum Test Duration = 2.0 ms, One Output Loaded at a Time
I <sub>OZ</sub>	Maximum Tri-State Leakage Current		±10.0		μA	V <sub>IN</sub> = V <sub>CC</sub> , GND V <sub>IN</sub> (OE, R/W, $\overline{CE}$ , STB) = V <sub>IL</sub> , V <sub>IH</sub>
I <sub>OZT</sub>	Maximum I/O Leakage Current		±11.0		μA	V <sub>IN</sub> = V <sub>CC</sub> , GND V <sub>O</sub> = V <sub>CC</sub> , GND V <sub>IN</sub> (R/W, $\overline{CE}$ , STB) = V <sub>IL</sub> , V <sub>IH</sub>
I <sub>CC</sub>	Maximum Quiescent Supply Current	5.5	160		μA	TDI, $\overline{OE}$ Float
I <sub>CCmax</sub>	Maximum Quiescent Supply Current	5.5	920		μA	TDI, $\overline{OE}$ low
I <sub>CCT</sub>	Maximum I <sub>CC</sub> /Input	5.5	1.60		mA	V <sub>IN</sub> = V <sub>CC</sub> - 2.1V Float: TDI, $\overline{OE}$
I <sub>CCTR</sub>	Maximum I <sub>CC</sub> /Input	5.5	1.65		mA	V <sub>IN</sub> = V <sub>CC</sub> - 2.1V TDI and OE Only Float Untested Pin

**AC ELECTRICAL CHARACTERISTICS/OPERATING REQUIREMENTS**

Symbol	Parameter	V <sub>CC</sub> (V) <sup>(1)</sup>	Military		Units	Fig. No.
			T <sub>A</sub> = -55°C to +125°C			
			C <sub>L</sub> = 50 pF			
			Min	Max		
<b>PARALLEL PROCESSOR INTERFACE (PPI)</b>						
t <sub>pd1</sub>	Prop Delay R/W to RDY	5.0	5.5	19.5	ns	4, 5, 6
t <sub>pd2</sub>	Prop Delay A to RDY	5.0	5.5	21.0	ns	4, 5
t <sub>pd3</sub>	Prop Delay A to D	5.0	6.5	24.0	ns	5
t <sub>pd4</sub>	Prop Delay STB to RDY	5.0	7.0	24.0	ns	4-6, 8
t <sub>pd10</sub>	Prop Delay SCK to D	5.0	7.5	39.0	ns	4-6, 8
t <sub>pd11</sub>	Prop Delay SCK to INT	5.0	9.0	34.0	ns	4-6, 8
t <sub>pd12</sub>	Prop Delay SCK to RDY	5.0	10.0	36.0	ns	4-6, 8
t <sub>en1</sub>	Enable Time $\overline{CE}$ to RDY	5.0	2.0	13.0	ns	4, 5
t <sub>dis1</sub>	Disable Time $\overline{CE}$ to RDY	5.0	1.5	10.0	ns	4, 5
t <sub>en2</sub>	Enable Time $\overline{CE}$ to D	5.0	1.5	16.5	ns	5
t <sub>dis2</sub>	Disable Time $\overline{CE}$ to D	5.0	2.5	14.5	ns	5

(1) Voltage Range 5.0 is 5.0V ±0.5V.

**AC ELECTRICAL CHARACTERISTICS/OPERATING REQUIREMENTS (continued)**

Symbol	Parameter	V <sub>CC</sub> (V) <sup>(1)</sup>	Military		Units	Fig. No.
			T <sub>A</sub> = -55°C to +125°C			
			C <sub>L</sub> = 50 pF			
			Min	Max		
t <sub>en3</sub>	Enable Time R $\overline{W}$ to D	5.0	3.0	17.5	ns	5
t <sub>dis3</sub>	Disable Time R $\overline{W}$ to D	5.0	3.0	16.0	ns	5
t <sub>en</sub>	Enable Time STB to D	5.0	3.0	16.0	ns	5
t <sub>dis</sub>	Disable Time STB to D	5.0	2.5	14.5	ns	5
t <sub>h1</sub>	Hold Time, R $\overline{W}$ to STB	5.0	0.5		ns	4–6, 8
t <sub>s1</sub>	Setup Time R $\overline{W}$ to STB	5.0	1.0		ns	4–6, 8
t <sub>h2</sub>	Hold Time, A to STB $\uparrow$	5.0	4.5		ns	4, 5
t <sub>s2</sub>	Setup Time, A to STB $\uparrow$	5.0	5.0		ns	4, 5
t <sub>h3</sub>	Hold Time, D to STB $\uparrow$	5.0	4.5		ns	4
t <sub>s3</sub>	Setup Time, D to STB $\uparrow$	5.0	0.0		ns	4
t <sub>h</sub>	Hold Time, $\overline{CE}$ to STB	5.0	1.0		ns	4–6, 8
t <sub>s</sub>	Setup Time, $\overline{CE}$ to STB	5.0	0.5		ns	4–6, 8
t <sub>s4</sub>	Setup Time, STB $\uparrow$ to SCK $\downarrow$	5.0	7.5		ns	6–9
t <sub>h4</sub>	Hold Time, STB $\uparrow$ to SCK $\downarrow$	5.0	0.0		ns	6–9
t <sub>h</sub>	Hold Time, STB to $\overline{RDY}$	5.0	0.0		ns	6–9
t <sub>W</sub>	Clock Pulse Width, SCK, H or L	5.0	20.0		ns	6, 8
t <sub>W1</sub>	Pulse Width STB (H or L)	5.0	6.0		ns	6, 8
f <sub>max</sub>	Maximum Frequency Clock	5.0	25		MHz	
<b>SERIAL SCAN INTERFACE (SSI)</b>						
t <sub>pd5</sub>	Prop Delay SCK to TCK	5.0	3.0	14.0	ns	17
t <sub>pd6</sub>	Prop Delay SCK to TDO	5.0	5.5	19.5	ns	17
t <sub>pd7</sub>	Prop Delay SCK to TMS	5.0	4.5	18.5	ns	17
t <sub>pd8</sub>	Prop Delay FRZ to TCK	5.0	3.0	13.5	ns	17
t <sub>pd9</sub>	Prop Delay TDI to TDO	5.0	1.5	10.0	ns	17
t <sub>en4</sub>	Enable Time $\overline{OE}$ to JTAG	5.0	2.0	13.0	ns	16
t <sub>dis4</sub>	Disable Time $\overline{OE}$ to JTAG	5.0	1.5	11.0	ns	16
t <sub>h5</sub>	Hold Time, H or L, TDI to SCK <sup>(2)</sup>	5.0	0.5		ns	17
t <sub>s5</sub>	Setup Time, H or L, TDI to SCK <sup>(2)</sup>	5.0	7.5		ns	17
<b>RST RELATED TIMING</b>						
t <sub>pd</sub>	Prop Delay $\overline{RST}$ to D	5.0	8.0	29.5	ns	
t <sub>pd</sub>	Prop Delay $\overline{RST}$ to $\overline{RDY}$	5.0	8.0	31.0	ns	
t <sub>phl</sub>	Prop Delay $\overline{RST}$ to INT	5.0	7.0	28.0	ns	
t <sub>plh</sub>	Prop Delay $\overline{RST}$ to TDO	5.0	5.5	21.0	ns	

(2) SSC Mode

**AC ELECTRICAL CHARACTERISTICS/OPERATING REQUIREMENTS (continued)**

Symbol	Parameter	V <sub>CC</sub> (V) <sup>(1)</sup>	Military		Units	Fig. No.
			T <sub>A</sub> = -55°C to +125°C			
			C <sub>L</sub> = 50 pF			
			Min	Max		
t <sub>plh</sub>	Prop Delay $\overline{\text{RST}}$ to TMS	5.0	5.5	20.0	ns	
t <sub>WR</sub>	Pulse Width $\overline{\text{RST}}$ (L)	5.0	6.5		ns	
t <sub>REC</sub>	Recovery Time SCK from $\overline{\text{RST}}$	5.0	1.0		ns	

**APPLICATION NOTE****SCK Minimum Pulse Width Calculation**

The SCANPSC100 Parallel to Serial Converter is intended to act as the interface between a processor and an IEEE 1149.1 boundary scan chain. When used in this configuration, there is a critical timing situation that is not obvious. This timing involves the system clock rate at which data from the scan ring is being read into the 'PSC100's TDI pin (target TAP controllers in SHIFT-DR or SHIFT-IR states).

To fully understand the events which are taking place during this critical period, it is useful to view the waveforms of interest as they relate in time. See [Figure 18](#). The TCK is derived internally to the 'PSC100 based on the system clock (SCK) and clock gating control. The result is that when TCK is running, it is at the same frequency as SCK but delayed in time by the SCK-TCK propagation delay.

The TCK signal from the 'PSC100 drives all of the IEEE 1149.1 target devices. On the rising edge of TCK, data present at each scan cell is clocked into it. On the falling edge, this data is presented at the output of the same scan cell for the next adjacent cell to read. With regards to the last cell in a particular target, the falling edge of TCK presents the data in the last scan cell to the TDO pin, a TCK-TDO propagation delay later.

At the 'PSC100, data shifted in through the TDI pin is clocked in on the rising edge of SCK, not TCK. The reason for this is that TCK is generated internal to the 'PSC100 and intended to control the boundary scan targets. The 'PSC100 is controlled by SCK, therefore the signal to be shifted into the TDI pin needs to be referenced to SCK not TCK. New TDI data must be present a TDI-SCK set-up time prior to the rising edge of SCK in order to ensure validity. Although SCK is usually continuous, the TDI buffer is controlled by a SHIFT-ENABLE signal which is generated internal to the 'PSC100, based on the status of the TDI buffer and the Mode Registers.

We now see the three major timing components which limit the duration of the SCK pulse width low. There are two minor additional delays which should be noted. The TCK signal from the 'PSC100 needs to arrive at the target device to be recognized, and this takes a finite amount of time depending on the signal trace length and impedance. Similarly, the TDO signal of the last target in the chain needs to reach the TDI pin of the 'PSC100, taking a finite amount of time as well. These two trace delays can be minimized by making the target device closest to the 'PSC100 the last device in the chain. See [Figure 19](#).

**Programming Restrictions**

Because certain mode bits enable shift operations for certain functions, these mode bits should not be changed when shift operations are in progress. The alignment of all registers during shift operations is controlled by a three bit counter in the TCK control block. Enabling or disabling a function in the middle of a shift operation may disrupt the logic necessary to keep all shifter/buffers byte-aligned. For example, if the TDO shifter/buffer (already loaded) is enabled while the three bit counter value is three, the shifter/buffer will only shift out 5 bits of the first byte loaded.

The following bits should not be changed when shift operations are in progress, i.e., when TCK is enabled (see [TCK Control](#) section):

- MODE0(7:3)
- MODE1(4:3)
- MODE2(0)



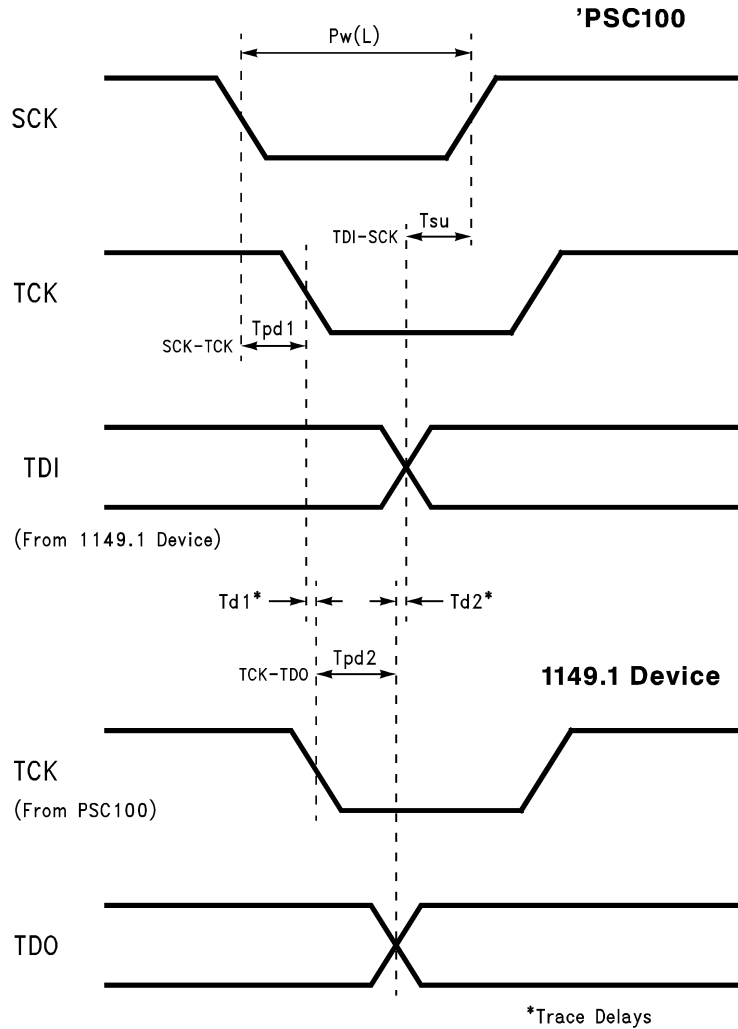

$$Pw(L) \text{ minimum} = Tpd1 + Td1 + Tpd2 + Td2 + Tsu$$

**Figure 18. System Clock Timing for Accurate TDI Data**

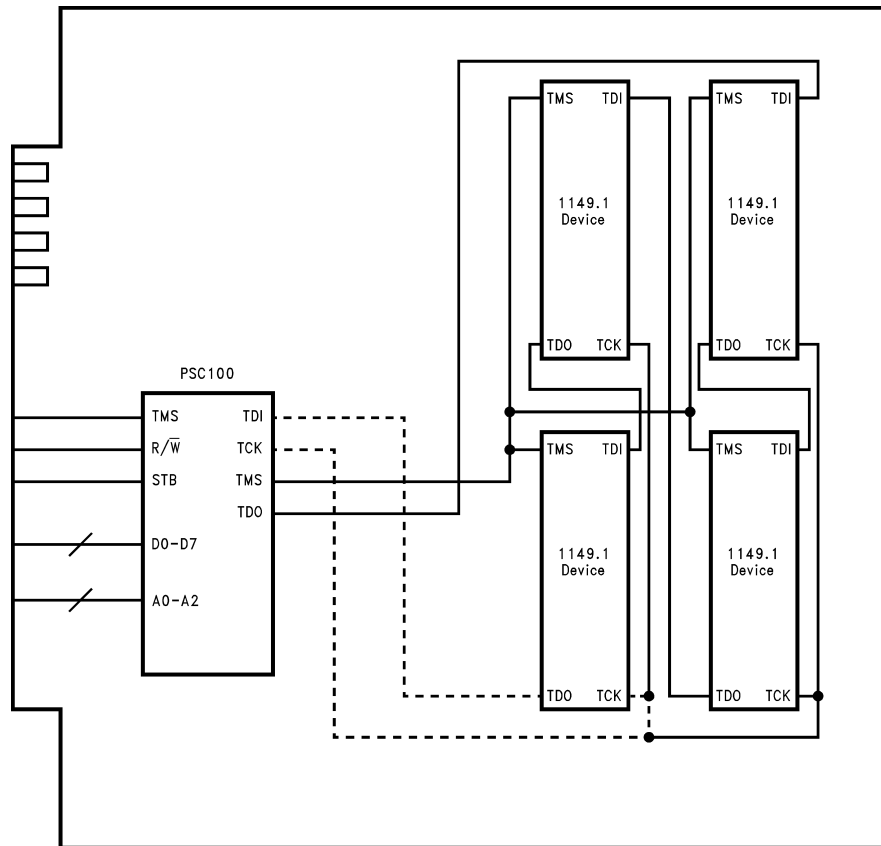

**Note:** - - - - Minimize the lengths of these two traces.

**Figure 19. SCANPSC100 Location Relative to Targets**

---

**REVISION HISTORY**

<b>Changes from Revision C (April 2013) to Revision D</b>	<b>Page</b>
• Changed layout of National Data Sheet to TI format .....	<a href="#">26</a>

---

## IMPORTANT NOTICE

Texas Instruments Incorporated and its subsidiaries (TI) reserve the right to make corrections, enhancements, improvements and other changes to its semiconductor products and services per JESD46, latest issue, and to discontinue any product or service per JESD48, latest issue. Buyers should obtain the latest relevant information before placing orders and should verify that such information is current and complete. All semiconductor products (also referred to herein as "components") are sold subject to TI's terms and conditions of sale supplied at the time of order acknowledgment.

TI warrants performance of its components to the specifications applicable at the time of sale, in accordance with the warranty in TI's terms and conditions of sale of semiconductor products. Testing and other quality control techniques are used to the extent TI deems necessary to support this warranty. Except where mandated by applicable law, testing of all parameters of each component is not necessarily performed.

TI assumes no liability for applications assistance or the design of Buyers' products. Buyers are responsible for their products and applications using TI components. To minimize the risks associated with Buyers' products and applications, Buyers should provide adequate design and operating safeguards.

TI does not warrant or represent that any license, either express or implied, is granted under any patent right, copyright, mask work right, or other intellectual property right relating to any combination, machine, or process in which TI components or services are used. Information published by TI regarding third-party products or services does not constitute a license to use such products or services or a warranty or endorsement thereof. Use of such information may require a license from a third party under the patents or other intellectual property of the third party, or a license from TI under the patents or other intellectual property of TI.

Reproduction of significant portions of TI information in TI data books or data sheets is permissible only if reproduction is without alteration and is accompanied by all associated warranties, conditions, limitations, and notices. TI is not responsible or liable for such altered documentation. Information of third parties may be subject to additional restrictions.

Resale of TI components or services with statements different from or beyond the parameters stated by TI for that component or service voids all express and any implied warranties for the associated TI component or service and is an unfair and deceptive business practice. TI is not responsible or liable for any such statements.

Buyer acknowledges and agrees that it is solely responsible for compliance with all legal, regulatory and safety-related requirements concerning its products, and any use of TI components in its applications, notwithstanding any applications-related information or support that may be provided by TI. Buyer represents and agrees that it has all the necessary expertise to create and implement safeguards which anticipate dangerous consequences of failures, monitor failures and their consequences, lessen the likelihood of failures that might cause harm and take appropriate remedial actions. Buyer will fully indemnify TI and its representatives against any damages arising out of the use of any TI components in safety-critical applications.

In some cases, TI components may be promoted specifically to facilitate safety-related applications. With such components, TI's goal is to help enable customers to design and create their own end-product solutions that meet applicable functional safety standards and requirements. Nonetheless, such components are subject to these terms.

No TI components are authorized for use in FDA Class III (or similar life-critical medical equipment) unless authorized officers of the parties have executed a special agreement specifically governing such use.

Only those TI components which TI has specifically designated as military grade or "enhanced plastic" are designed and intended for use in military/aerospace applications or environments. Buyer acknowledges and agrees that any military or aerospace use of TI components which have **not** been so designated is solely at the Buyer's risk, and that Buyer is solely responsible for compliance with all legal and regulatory requirements in connection with such use.

TI has specifically designated certain components as meeting ISO/TS16949 requirements, mainly for automotive use. In any case of use of non-designated products, TI will not be responsible for any failure to meet ISO/TS16949.

### Products

Audio	<a href="http://www.ti.com/audio">www.ti.com/audio</a>
Amplifiers	<a href="http://amplifier.ti.com">amplifier.ti.com</a>
Data Converters	<a href="http://dataconverter.ti.com">dataconverter.ti.com</a>
DLP® Products	<a href="http://www.dlp.com">www.dlp.com</a>
DSP	<a href="http://dsp.ti.com">dsp.ti.com</a>
Clocks and Timers	<a href="http://www.ti.com/clocks">www.ti.com/clocks</a>
Interface	<a href="http://interface.ti.com">interface.ti.com</a>
Logic	<a href="http://logic.ti.com">logic.ti.com</a>
Power Mgmt	<a href="http://power.ti.com">power.ti.com</a>
Microcontrollers	<a href="http://microcontroller.ti.com">microcontroller.ti.com</a>
RFID	<a href="http://www.ti-rfid.com">www.ti-rfid.com</a>
OMAP Applications Processors	<a href="http://www.ti.com/omap">www.ti.com/omap</a>
Wireless Connectivity	<a href="http://www.ti.com/wirelessconnectivity">www.ti.com/wirelessconnectivity</a>

### Applications

Automotive and Transportation	<a href="http://www.ti.com/automotive">www.ti.com/automotive</a>
Communications and Telecom	<a href="http://www.ti.com/communications">www.ti.com/communications</a>
Computers and Peripherals	<a href="http://www.ti.com/computers">www.ti.com/computers</a>
Consumer Electronics	<a href="http://www.ti.com/consumer-apps">www.ti.com/consumer-apps</a>
Energy and Lighting	<a href="http://www.ti.com/energy">www.ti.com/energy</a>
Industrial	<a href="http://www.ti.com/industrial">www.ti.com/industrial</a>
Medical	<a href="http://www.ti.com/medical">www.ti.com/medical</a>
Security	<a href="http://www.ti.com/security">www.ti.com/security</a>
Space, Avionics and Defense	<a href="http://www.ti.com/space-avionics-defense">www.ti.com/space-avionics-defense</a>
Video and Imaging	<a href="http://www.ti.com/video">www.ti.com/video</a>

### TI E2E Community

[e2e.ti.com](http://e2e.ti.com)