

LM6118,LM6218

LM6118/LM6218 Fast Settling Dual Operational Amplifiers



Literature Number: SNOS541B

LM6118/LM6218

Fast Settling Dual Operational Amplifiers

General Description

The LM6118/LM6218 are monolithic fast-settling unity-gain-compensated dual operational amplifiers with ± 20 mA output drive capability. The PNP input stage has a typical bias current of 200 nA, and the operating supply voltage is ± 5 V to ± 20 V.

These dual op amps use slew enhancement with special mirror circuitry to achieve fast response and high gain with low total supply current.

The amplifiers are built on a junction-isolated VIP™ (Vertically Integrated PNP) process which produces fast PNP's that complement the standard NPN's.

Features

- Low offset voltage:
- 0.01% settling time:
- Slew rate $A_V = -1$:
- Slew rate $A_V = +1$:
- Gain bandwidth:
- Total supply current:
- Output drives 50 Ω load (± 1 V)

Typical	
0.2 mV	Low offset voltage
400 ns	0.01% settling time
140 V/ μ s	Slew rate $A_V = -1$
75 V/ μ s	Slew rate $A_V = +1$
17 MHz	Gain bandwidth
5.5 mA	Total supply current

Applications

- D/A converters
- Fast integrators
- Active filters

Connection Diagrams and Order Information

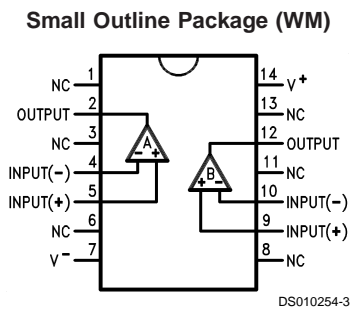

Top View

Order Number **LM6218WM, LM6218WMX**
See NS Package Number **M14B**

Dual-In-Line Package (J or N)

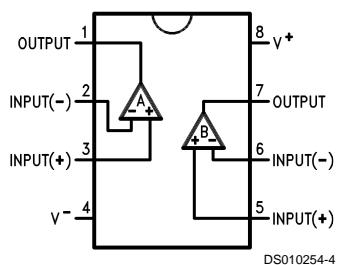

Top View

Order Number **LM6118J/883 or LM6218N**
See NS Package Number **N08E, J08A**

Typical Applications

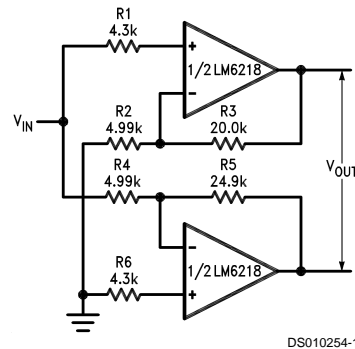

Single ended input to differential output
 $A_V = 10$, BW = 3.2 MHz
 40 V_{PP} Response = 1.4 MHz
 $V_S = \pm 15$ V

Wide-Band, Fast-Settling 40 V_{PP} Amplifier

Absolute Maximum Ratings (Note 1)

If Military/Aerospace specified devices are required, please contact the National Semiconductor Sales Office/Distributors for availability and specifications.

Total Supply Voltage	42V
Input Voltage	(Note 2)
Differential Input Current (Note 3)	±10 mA
Output Current (Note 4)	Internally Limited
Power Dissipation (Note 5)	500 mW
ESD Tolerance	

(C = 100 pF, R = 1.5 kΩ)	±2 kV
Junction Temperature	150°C
Storage Temperature Range	-65°C to +150°C
Lead Temperature (Soldering, 10 sec.)	300°C

Operating Temp. Range

LM6118	-55°C to +125°C
LM6218	-40°C to +85°C

Electrical Characteristics

±5V ≤ V_S ≤ ±20V, V_{CM} = 0V, V_{OUT} = 0V, I_{OUT} = 0A, unless otherwise specified. Limits with standard type face are for T_J = 25°C, and **Bold Face Type** are for **Temperature Extremes**.

Parameter	Conditions	Typ 25°C	LM6118 Limits (Note 6)	LM6218 Limits (Note 6)	Units
Input Offset Voltage	V _S = ±15V	0.2	1 2	3 4	mV (max)
Input Offset Voltage	V ₋ + 3V ≤ V _{CM} ≤ V ₊ - 3.5V	0.3	1.5 2.5	3.5 4.5	mV (max)
Input Offset Current	V ₋ + 3V ≤ V _{CM} ≤ V ₊ - 3.5V	20	50 250	100 200	nA (max)
Input Bias Current	V ₋ + 3V ≤ V _{CM} ≤ V ₊ - 3.5V	200	350 950	500 1250	nA (max)
Input Common Mode Rejection Ratio	V ₋ + 3V ≤ V _{CM} ≤ V ₊ - 3.5V V _S = ±20V	100	90 85	80 75	dB (min)
Positive Power Supply Rejection Ratio	V ₋ = -15V 5V ≤ V ₊ ≤ 20V	100	90 85	80 75	dB (min)
Negative Power Supply Rejection Ratio	V ₊ = 15V -20V ≤ V ₋ ≤ -5V	100	90 85	80 75	dB (min)
Large Signal Voltage Gain	V _{out} = ±15V R _L = 10k V _S = ±20V	500	150 100	100 70	V/mV (min)
	V _{out} = ±10V R _L = 500 V _S = ±15V (±20 mA)	200	50 30	40 25	V/mV (min)
V _O Output Voltage Swing	Supply = ±20V R _L = 10k	17.3	±17	±17	V (min)
Total Supply Current	V _S = ±15V	5.5	7 7.5	7 7.5	mA (max)
Output Current Limit	V _S = ±15V, Pulsed	65	100	100	mA (max)
Slew Rate, A _v = -1	V _S = ±15V, V _{out} = ±10V R _S = R _f = 2k, C _f = 10 pF	140	100 50	100 50	V/μs (min)
Slew Rate, A _v = +1	V _S = ±15V, V _{out} = ±10V R _S = R _f = 2k, C _f = 10 pF	75	50 30	50 30	V/μs (min)
Gain-Bandwidth Product	V _S = ±15V, f _o = 200 kHz	17	14	13	MHz (min)
0.01% Settling Time A _v = -1	ΔV _{out} = 10V, V _S = ±15V, R _S = R _f = 2k, C _f = 10 pF	400			ns
Input Capacitance	Inverter	5			pF
	Follower	3			pF

Note 1: Absolute Maximum Ratings indicate limits beyond which damage to the device may occur. DC and AC electrical specifications do not apply when operating the device beyond its rated operating conditions.

Note 2: Input voltage range is (V⁺ - 1V) to (V⁻).

Note 3: The inputs are shunted with three series-connected diodes back-to-back for input differential clamping. Therefore differential input voltages greater than about 1.8V will cause excessive current to flow unless limited to less than 10 mA.

Electrical Characteristics (Continued)

Note 4: Current limiting protects the output from a short to ground or any voltage less than the supplies. With a continuous overload, the package dissipation must be taken into account and heat sinking provided when necessary.

Note 5: Devices must be derated using a thermal resistance of 90°C/W for the N and WM packages.

Note 6: Limits are guaranteed by testing or correlation.

Typical Performance Characteristics

Input Bias Current

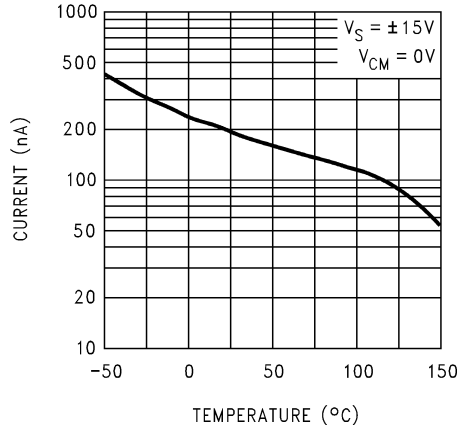

Input Noise Voltage

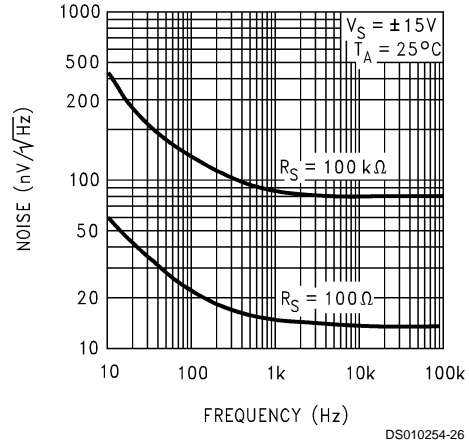

Common Mode Limits

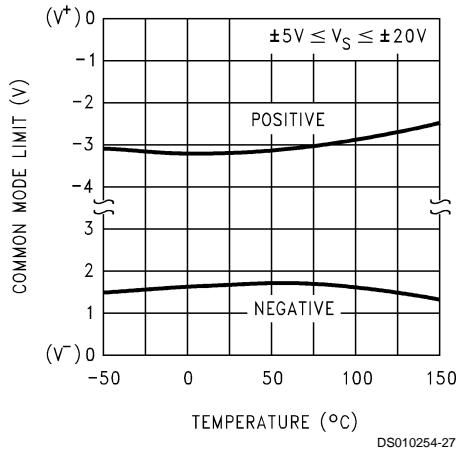

Common Mode Rejection

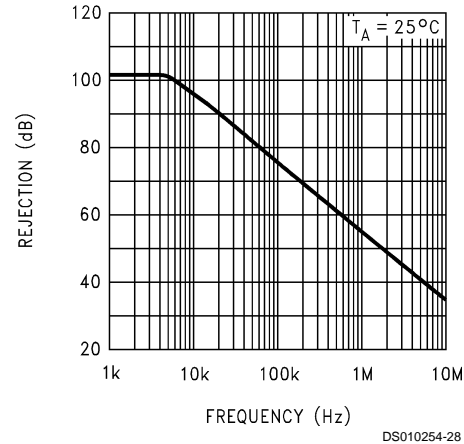

Power Supply Rejection

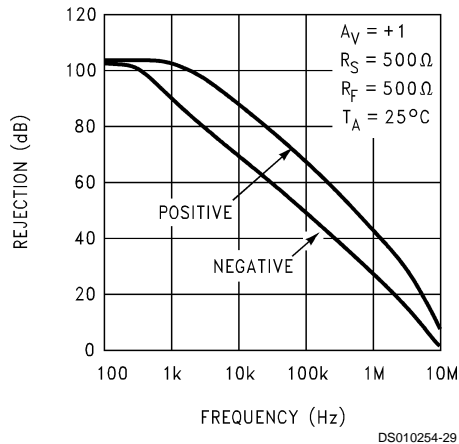

Frequency Response High Frequency

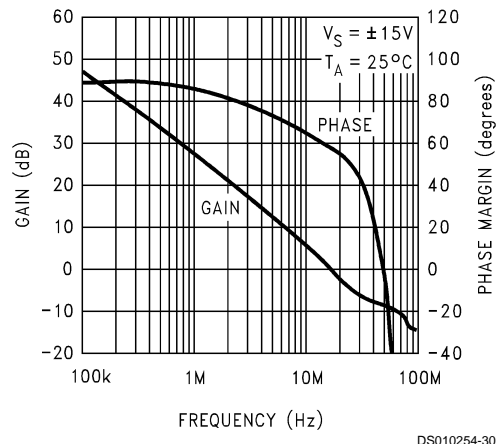

Typical Performance Characteristics (Continued)

Unity Gain Bandwidth

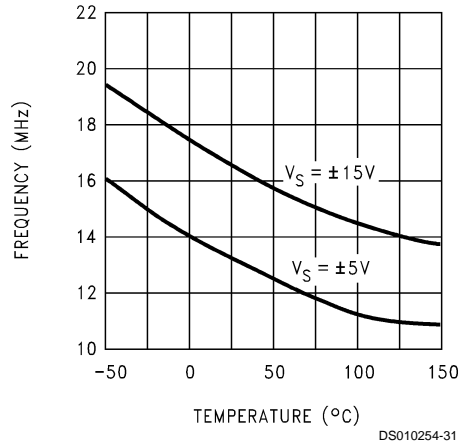

Unity Gain Bandwidth vs Output Load

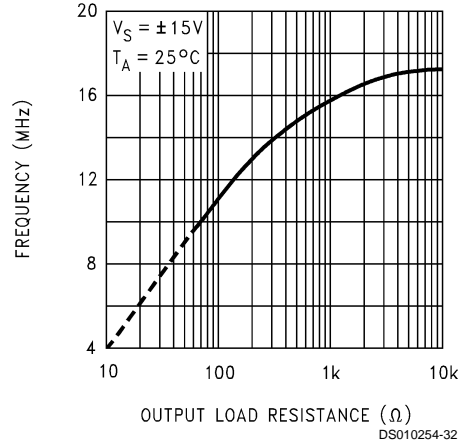

Large Signal Response (Sine Wave)

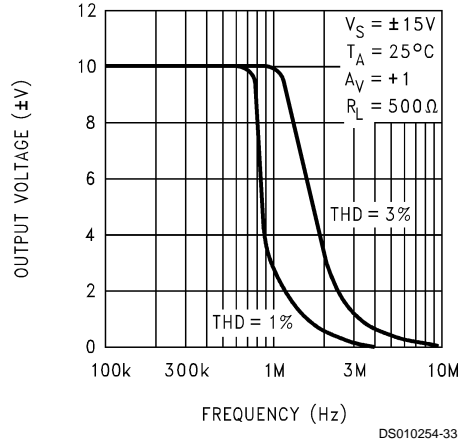

Total Harmonic Distortion

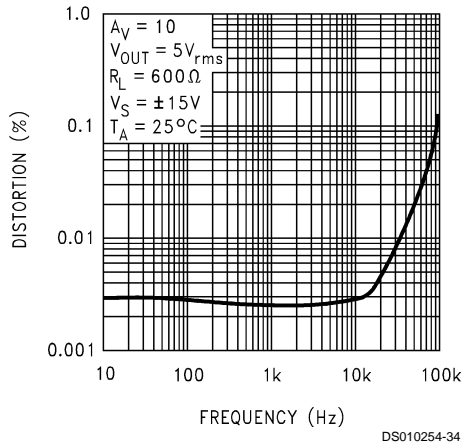

Output Impedance

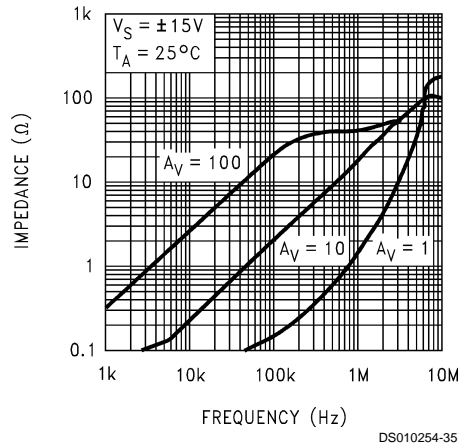

Output Saturation

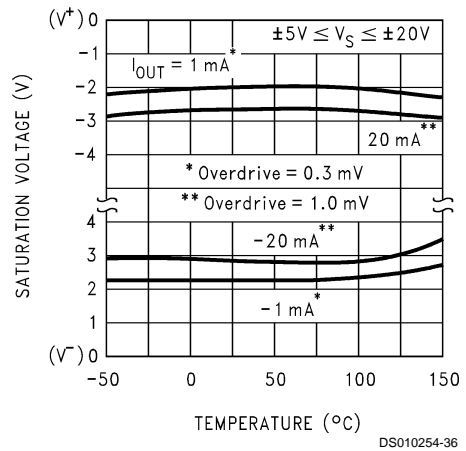

Typical Performance Characteristics (Continued)

Output Current Limit

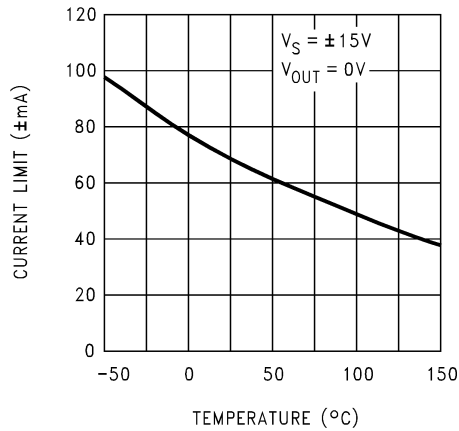

Supply Current (Both Amplifiers)

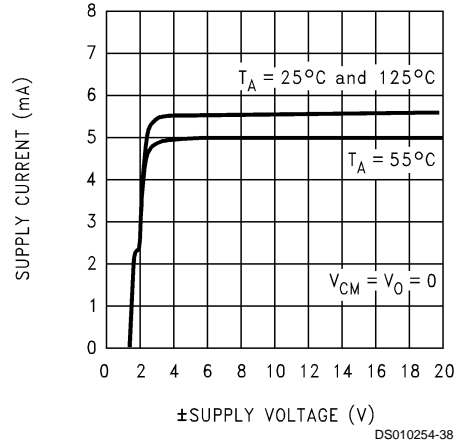

Slew Rate

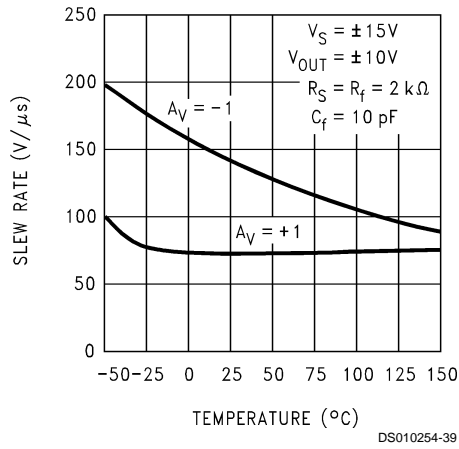

Inverter Settling Time

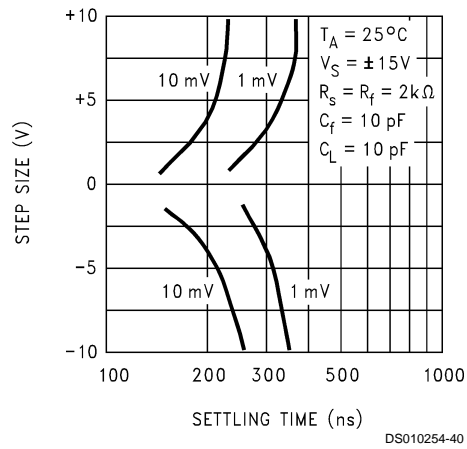

Follower Settling Time

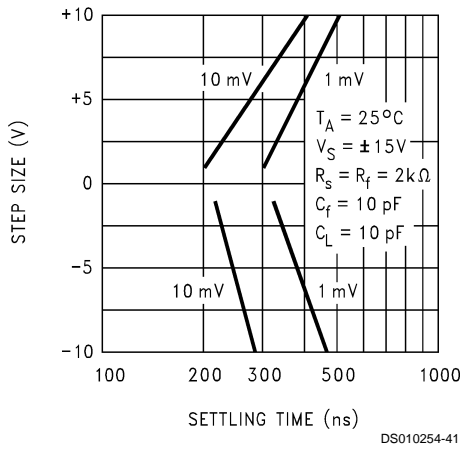

Typical Stability Range

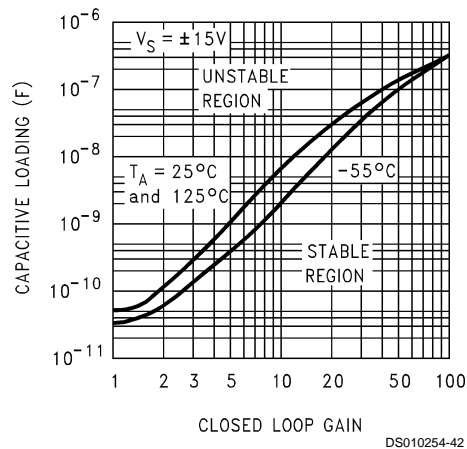

Typical Performance Characteristics (Continued)

Amplifier to Amplifier Coupling

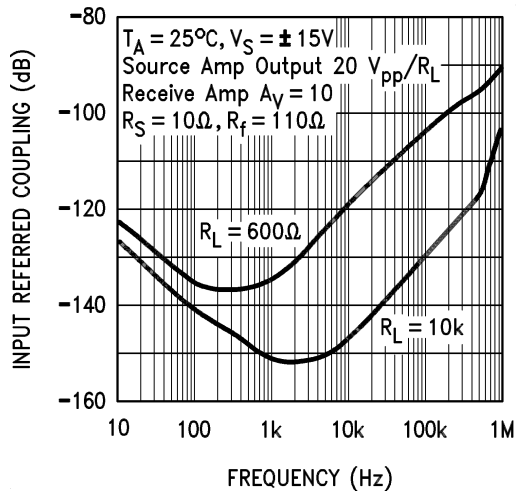

DS010254-23

Settling Time, $V_S = \pm 15\text{V}$

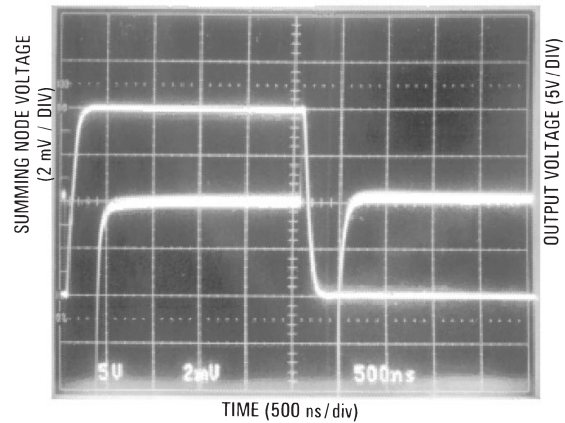

DS010254-7

Step Response, $A_V = +1$, $V_S = \pm 15\text{V}$

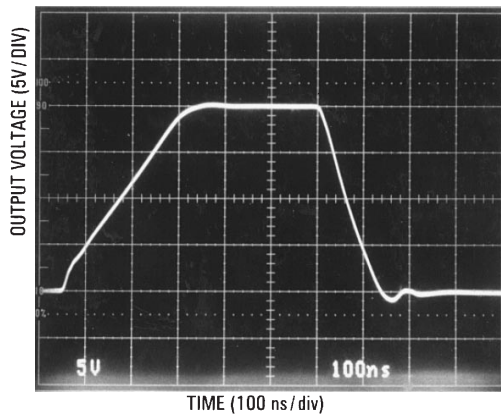

DS010254-8

Step Response, $A_V = -1$, $V_S = \pm 15\text{V}$

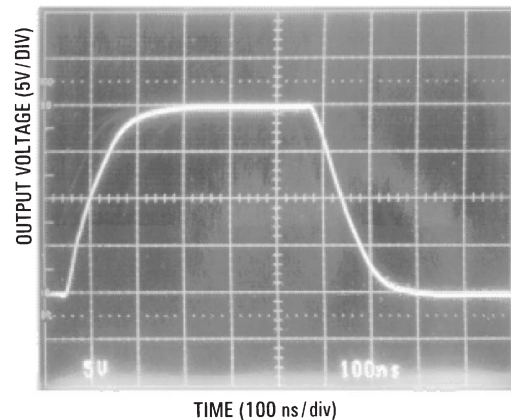

DS010254-9

Application Information

General

The LM6118/LM6218 are high-speed, fast-settling dual op-amps. To insure maximum performance, circuit board layout is very important. Minimizing stray capacitance at the inputs and reducing coupling between the amplifier's input and output will minimize problems.

Supply Bypassing

To assure stability, it is recommended that each power supply pin be bypassed with a 0.1 μF low inductance capacitor near the device. If high frequency spikes from digital circuits or switching supplies are present, additional filtering is recommended. To prevent these spikes from appearing at the output, R-C filtering of the supplies near the device may be necessary.

Power Dissipation

These amplifiers are specified to 20 mA output current. If accompanied with high supply voltages, relatively high power dissipation in the device will occur, resulting in high

junction temperatures. In these cases the package thermal resistance must be taken into consideration. (See Note 5 under Electrical Characteristics.) For high dissipation, an N package with large areas of copper on the pc board is recommended.

Amplifier Shut Down

If one of the amplifiers is not used, it can be shut down by connecting both the inverting and non-inverting inputs to the V^- pin. This will reduce the power supply current by approximately 25%.

Capacitive Loading

Maximum capacitive loading is about 50 pF for a closed-loop gain of +1, before the amplifier exhibits excessive ringing and becomes unstable. A curve showing maximum capacitive loads, with different closed-loop gains, is shown in the Typical Performance Characteristics section.

To drive larger capacitive loads at low closed-loop gains, isolate the amplifier output from the capacitive load with

Application Information (Continued)

50Ω. Connect a small capacitor directly from the amplifier output to the inverting input. The feedback loop is closed from the isolated output with a series resistor to the inverting input.

Voltage Follower

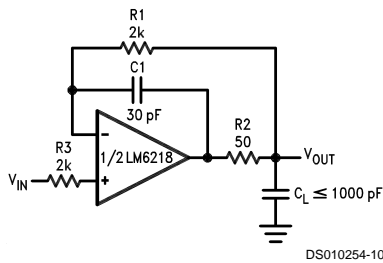

DS010254-10

For $C_L = 1000$ pF, Small signal BW = 5 MHz
20 V_{p-p} BW = 500 kHz

Inverter

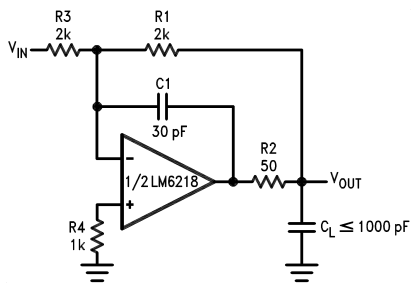

DS010254-11

Settling time to 0.01%, 10V Step

For $C_L = 1000$ pF, settling time ≈ 1500 ns

For $C_L = 300$ pF, settling time ≈ 500 ns

Integrator

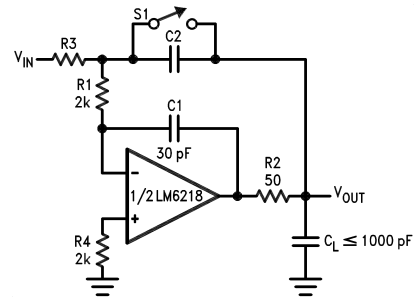

DS010254-12

Examples of unity gain connections for a voltage follower, Inverter, and integrator driving capacitive loads up to 1000 pF are shown here. Different R1–C1 time constants and capacitive loads will have an effect on settling times.

Input Bias Current Compensation

Input bias current of the first op amp can be reduced or balanced out by the second op amp. Both amplifiers are laid out in mirror image fashion and in close proximity to each other, thus both input bias currents will be nearly identical and will track with temperature. With both op amp inputs at the same potential, a second op amp can be used to convert bias current to voltage, and then back to current feeding the first op amp using large value resistors to reduce the bias current to the level of the offset current.

Examples are shown here for an inverting application, (a) where the inputs are at ground potential, and a second circuit (b) for compensating bias currents for both inputs.

Application Information (Continued)

Bias Current Compensation

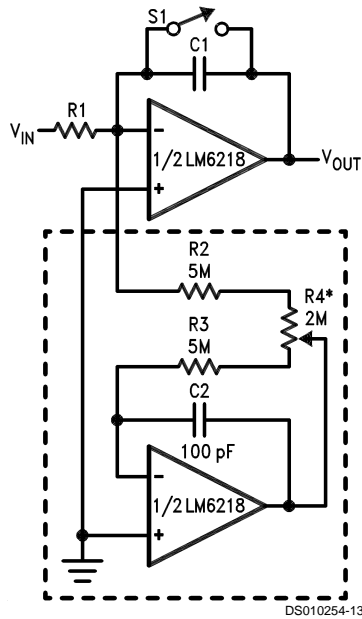

*adjust for zero integrator drift

(a) Inverting Input Bias Compensation for Integrator Application

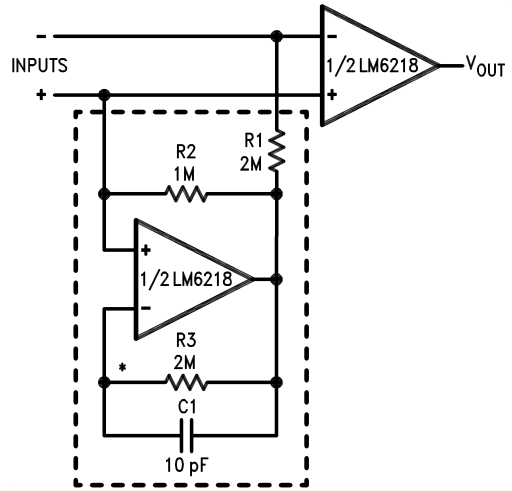

*mount resistor close to input pin to minimize stray capacitance

(b) Compensation to Both Inputs

Amplifier/Parallel Buffer

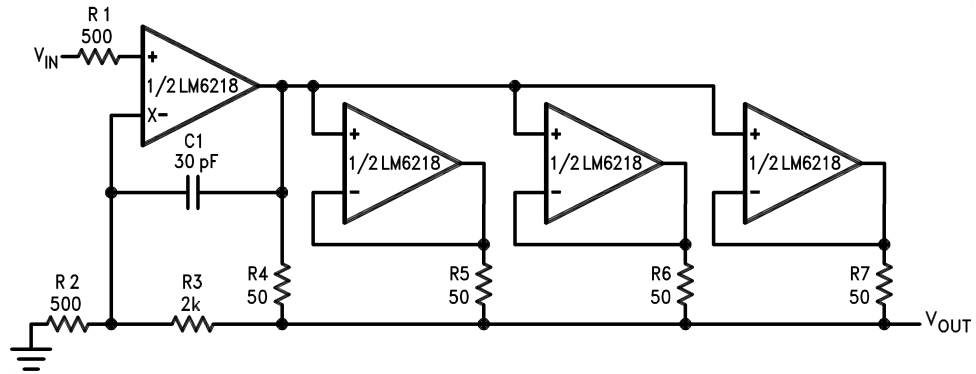

$A_V = +5$, $I_{OUT} \leq 80$ mA
 $V_S = \pm 15V$, $C_L \leq 0.01$ μF
 Large and small signal B.W. = 1.3 MHz (THD = 3%)

Application Information (Continued)

Constant-Voltage Crossover Network With 12 dB/Octave Slope

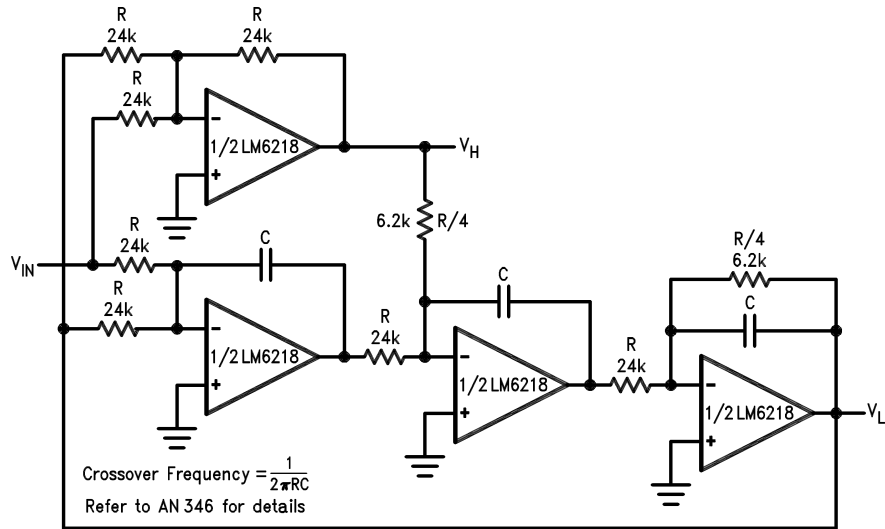

DS010254-16

Bilateral Current Source

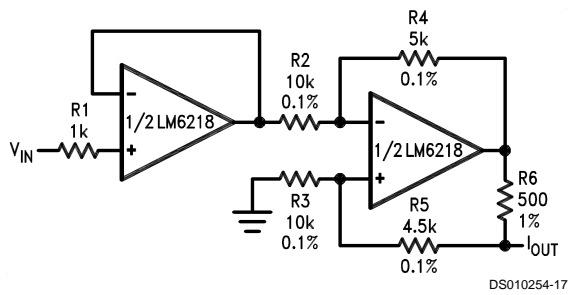

$V_S = \pm 15V, -10 \leq V_{IN} \leq 10V$

$$\frac{I_{OUT}}{V_{IN}} = \frac{R_4}{R_2 R_6} = \frac{1 \text{ mA}}{1V}$$

Output dynamic range = $10V - R_6 |I_{OUT}|$
 $R_L = 500\Omega$, small signal BW = 6 MHz
 Large signal response = 800 kHz

$$C_{out \text{ equiv.}} = \frac{R_2 + R_4}{2\pi f_0 R_2 R_6} = 32 \text{ pF} (f_0 = 15 \text{ MHz})$$

Coaxial Cable Driver

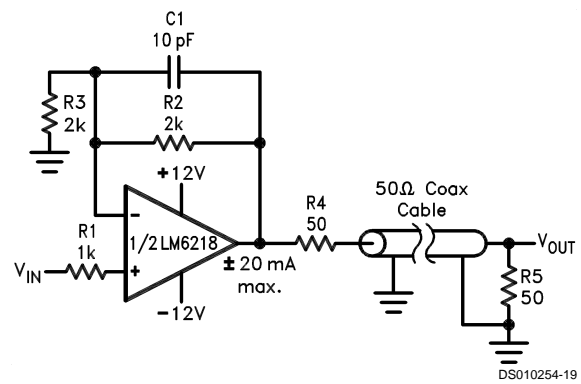

Small signal (200 mV_{p-p}) BW ≈ 5 MHz

Application Information (Continued)

Instrumentation Amplifier

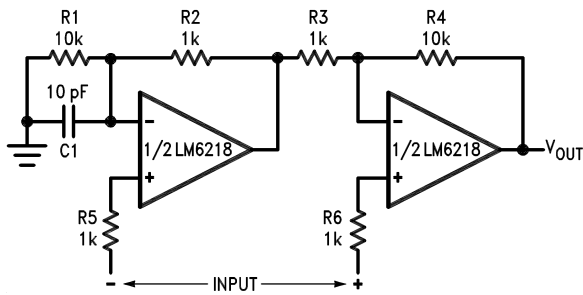

$A_V = 10$, $V_S = \pm 15V$, All resistors 0.01%
 Small signal and large signal (20 V_{P-P}) B.W. ≈ 800 kHz

DS010254-18

150 MHz Gain-Bandwidth Amplifier

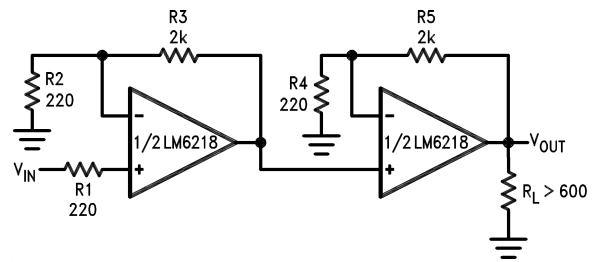

$A_V = 100$, $V_S = \pm 15V$,
 Small signal BW ≈ 1.5 MHz
 Large signal BW (20 V_{P-P}) ≈ 800 kHz

DS010254-20

Schematic Diagram

1/2 LM6118 (Op Amp A)

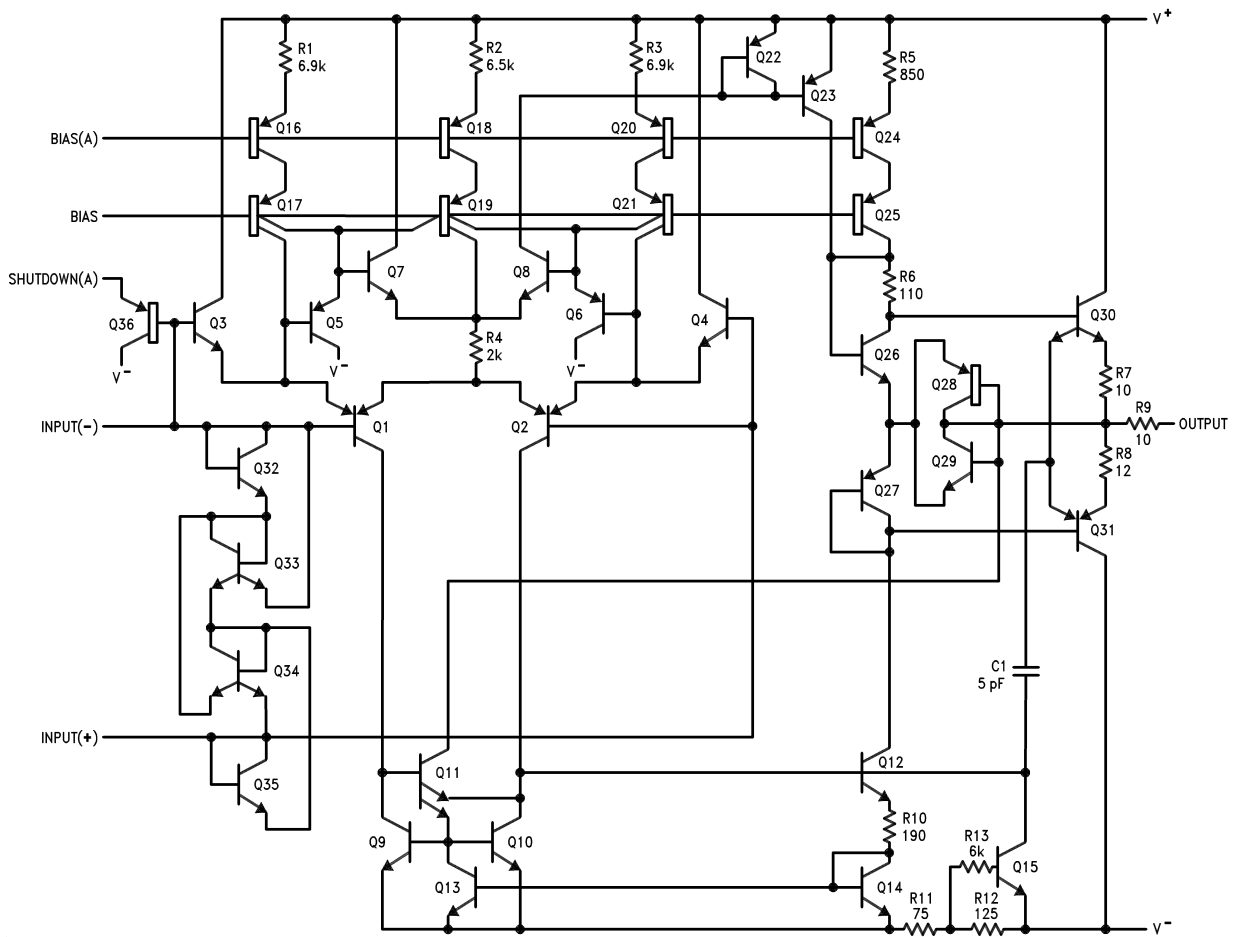

DS010254-21

Schematic Diagram (Continued)

Bias Circuit

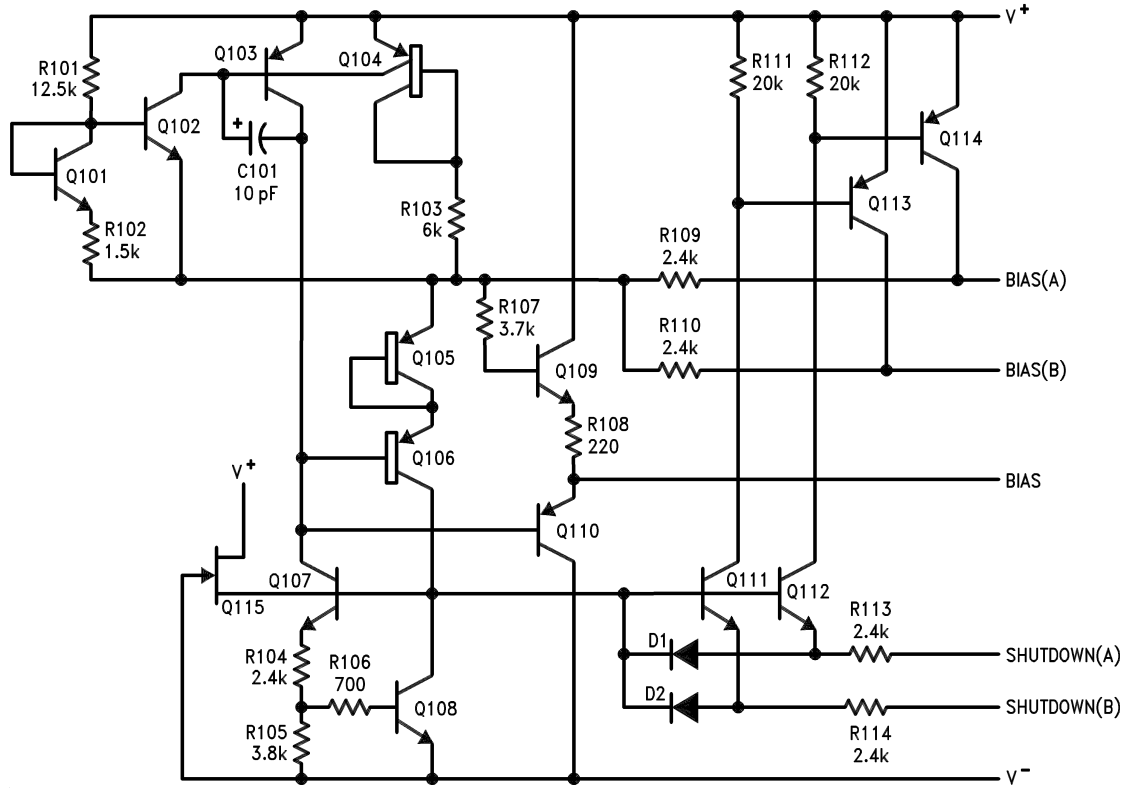

DS010254-22

Physical Dimensions inches (millimeters) unless otherwise noted

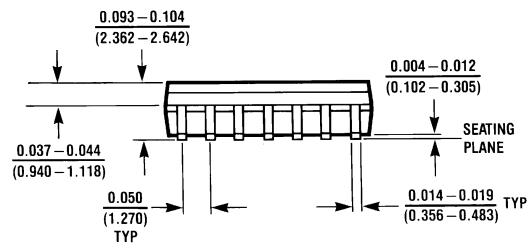
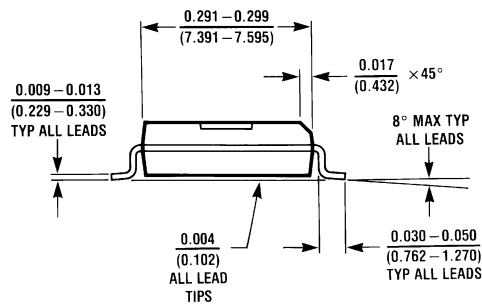
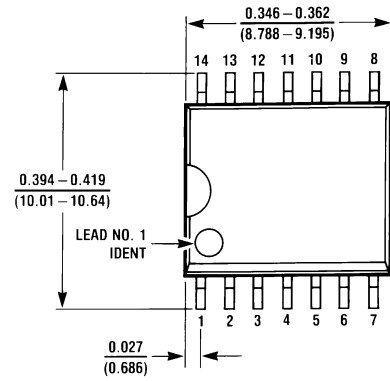

M14B (REV D)

8-Lead Molded Small Outline Package (M)
Order Number LM6218WM or LM6218WMX
NS Package Number M14B

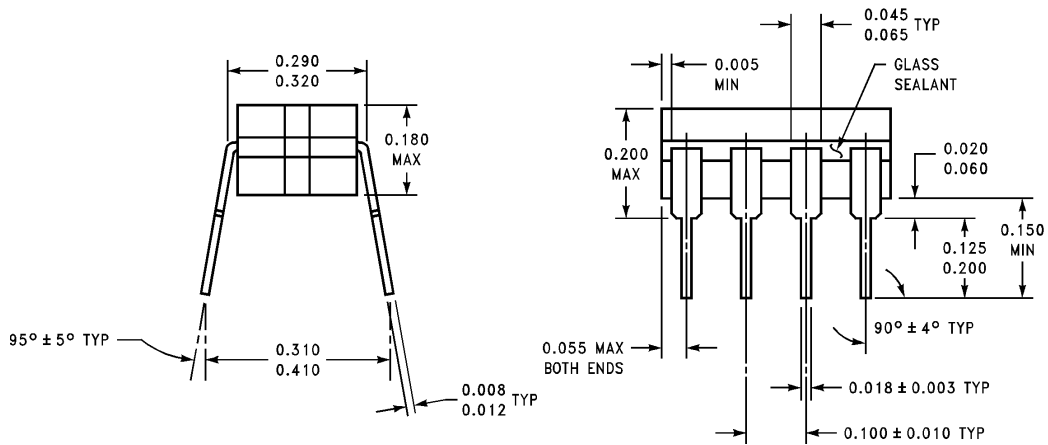
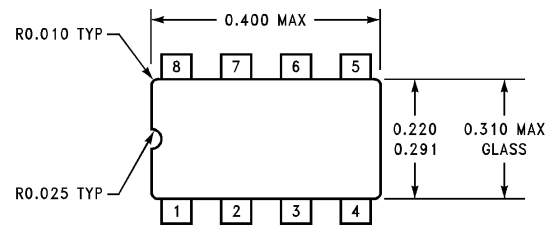

J08A (REV K)

8-Lead Molded Small Outline Package (M)
NS Package Number J08A

Physical Dimensions inches (millimeters) unless otherwise noted (Continued)

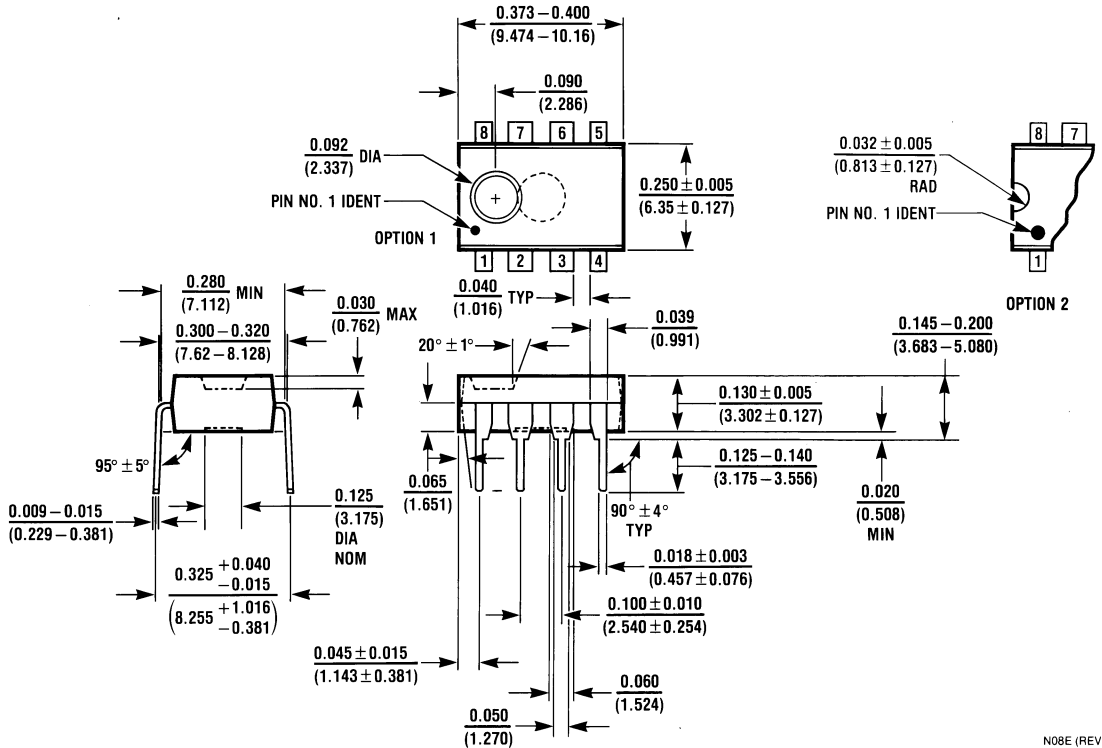

8-Lead Molded Dual-In-Line Package (N)
Order Number LM6218N
NS Package Number N08E

N08E (REV F)

LIFE SUPPORT POLICY

NATIONAL'S PRODUCTS ARE NOT AUTHORIZED FOR USE AS CRITICAL COMPONENTS IN LIFE SUPPORT DEVICES OR SYSTEMS WITHOUT THE EXPRESS WRITTEN APPROVAL OF THE PRESIDENT AND GENERAL COUNSEL OF NATIONAL SEMICONDUCTOR CORPORATION. As used herein:

1. Life support devices or systems are devices or systems which, (a) are intended for surgical implant into the body, or (b) support or sustain life, and whose failure to perform when properly used in accordance with instructions for use provided in the labeling, can be reasonably expected to result in a significant injury to the user.
2. A critical component is any component of a life support device or system whose failure to perform can be reasonably expected to cause the failure of the life support device or system, or to affect its safety or effectiveness.



National Semiconductor Corporation
Americas
Tel: 1-800-272-9959
Fax: 1-800-737-7018
Email: support@nsc.com
www.national.com

National Semiconductor Europe
Fax: +49 (0) 180-530 85 86
Email: europe.support@nsc.com
Deutsch Tel: +49 (0) 69 9508 6208
English Tel: +44 (0) 870 24 0 2171
Français Tel: +33 (0) 1 41 91 8790

National Semiconductor Asia Pacific Customer Response Group
Tel: 65-2544466
Fax: 65-2504466
Email: ap.support@nsc.com

National Semiconductor Japan Ltd.
Tel: 81-3-5639-7560
Fax: 81-3-5639-7507

IMPORTANT NOTICE

Texas Instruments Incorporated and its subsidiaries (TI) reserve the right to make corrections, modifications, enhancements, improvements, and other changes to its products and services at any time and to discontinue any product or service without notice. Customers should obtain the latest relevant information before placing orders and should verify that such information is current and complete. All products are sold subject to TI's terms and conditions of sale supplied at the time of order acknowledgment.

TI warrants performance of its hardware products to the specifications applicable at the time of sale in accordance with TI's standard warranty. Testing and other quality control techniques are used to the extent TI deems necessary to support this warranty. Except where mandated by government requirements, testing of all parameters of each product is not necessarily performed.

TI assumes no liability for applications assistance or customer product design. Customers are responsible for their products and applications using TI components. To minimize the risks associated with customer products and applications, customers should provide adequate design and operating safeguards.

TI does not warrant or represent that any license, either express or implied, is granted under any TI patent right, copyright, mask work right, or other TI intellectual property right relating to any combination, machine, or process in which TI products or services are used. Information published by TI regarding third-party products or services does not constitute a license from TI to use such products or services or a warranty or endorsement thereof. Use of such information may require a license from a third party under the patents or other intellectual property of the third party, or a license from TI under the patents or other intellectual property of TI.

Reproduction of TI information in TI data books or data sheets is permissible only if reproduction is without alteration and is accompanied by all associated warranties, conditions, limitations, and notices. Reproduction of this information with alteration is an unfair and deceptive business practice. TI is not responsible or liable for such altered documentation. Information of third parties may be subject to additional restrictions.

Resale of TI products or services with statements different from or beyond the parameters stated by TI for that product or service voids all express and any implied warranties for the associated TI product or service and is an unfair and deceptive business practice. TI is not responsible or liable for any such statements.

TI products are not authorized for use in safety-critical applications (such as life support) where a failure of the TI product would reasonably be expected to cause severe personal injury or death, unless officers of the parties have executed an agreement specifically governing such use. Buyers represent that they have all necessary expertise in the safety and regulatory ramifications of their applications, and acknowledge and agree that they are solely responsible for all legal, regulatory and safety-related requirements concerning their products and any use of TI products in such safety-critical applications, notwithstanding any applications-related information or support that may be provided by TI. Further, Buyers must fully indemnify TI and its representatives against any damages arising out of the use of TI products in such safety-critical applications.

TI products are neither designed nor intended for use in military/aerospace applications or environments unless the TI products are specifically designated by TI as military-grade or "enhanced plastic." Only products designated by TI as military-grade meet military specifications. Buyers acknowledge and agree that any such use of TI products which TI has not designated as military-grade is solely at the Buyer's risk, and that they are solely responsible for compliance with all legal and regulatory requirements in connection with such use.

TI products are neither designed nor intended for use in automotive applications or environments unless the specific TI products are designated by TI as compliant with ISO/TS 16949 requirements. Buyers acknowledge and agree that, if they use any non-designated products in automotive applications, TI will not be responsible for any failure to meet such requirements.

Following are URLs where you can obtain information on other Texas Instruments products and application solutions:

Products

Audio	www.ti.com/audio
Amplifiers	amplifier.ti.com
Data Converters	dataconverter.ti.com
DLP® Products	www.dlp.com
DSP	dsp.ti.com
Clocks and Timers	www.ti.com/clocks
Interface	interface.ti.com
Logic	logic.ti.com
Power Mgmt	power.ti.com
Microcontrollers	microcontroller.ti.com
RFID	www.ti-rfid.com
OMAP Mobile Processors	www.ti.com/omap
Wireless Connectivity	www.ti.com/wirelessconnectivity

Applications

Communications and Telecom	www.ti.com/communications
Computers and Peripherals	www.ti.com/computers
Consumer Electronics	www.ti.com/consumer-apps
Energy and Lighting	www.ti.com/energy
Industrial	www.ti.com/industrial
Medical	www.ti.com/medical
Security	www.ti.com/security
Space, Avionics and Defense	www.ti.com/space-avionics-defense
Transportation and Automotive	www.ti.com/automotive
Video and Imaging	www.ti.com/video

TI E2E Community Home Page

e2e.ti.com

Mailing Address: Texas Instruments, Post Office Box 655303, Dallas, Texas 75265
Copyright © 2011, Texas Instruments Incorporated