

LMX1501A, LMX1511

*LMX1501A LMX1511 PLLatinum(TM) 1.1 GHz Frequency Synthesizer for RF
Personal Communications*



Literature Number: SNOS747A

LMX1501A/LMX1511 PLLatinum™ 1.1 GHz Frequency Synthesizer for RF Personal Communications

General Description

The LMX1501A and the LMX1511 are high performance frequency synthesizers with integrated prescalers designed for RF operation up to 1.1 GHz. They are fabricated using National's ABiC IV BiCMOS process.

The LMX1501A and the LMX1511 contain dual modulus prescalers which can select either a 64/65 or a 128/129 divide ratio at input frequencies of up to 1.1 GHz. Using a proprietary digital phase locked loop technique, the LMX1501A/11's linear phase detector characteristics can generate very stable, low noise local oscillator signals.

Serial data is transferred into the LMX1501A and the LMX1511 via a three line MICROWIRE™ interface (Data, Enable, Clock). Supply voltage can range from 2.7V to 5.5V. The LMX1501A and the LMX1511 feature very low current consumption, typically 6 mA at 3V.

The LMX1501A is available in a JEDEC 16-pin surface mount plastic package. The LMX1511 is available in a TSSOP 20-pin surface mount plastic package.

Features

- RF operation up to 1.1 GHz
- 2.7V to 5.5V operation
- Low current consumption:
 $I_{CC} = 6 \text{ mA (typ)}$ at $V_{CC} = 3\text{V}$
- Dual modulus prescaler: 64/65 or 128/129
- Internal balanced, low leakage charge pump
- Small-outline, plastic, surface mount JEDEC, 0.150" wide, (1501A) or TSSOP, 0.173" wide, (1511) package

Applications

- Cellular telephone systems (AMPS, NMT, ETACS)
- Portable wireless communications (PCS/PCN, Cordless)
- Advanced cordless telephone systems (CT-1/CT-1+, CT-2, ISM902-928)
- Other wireless communication systems

Block Diagram

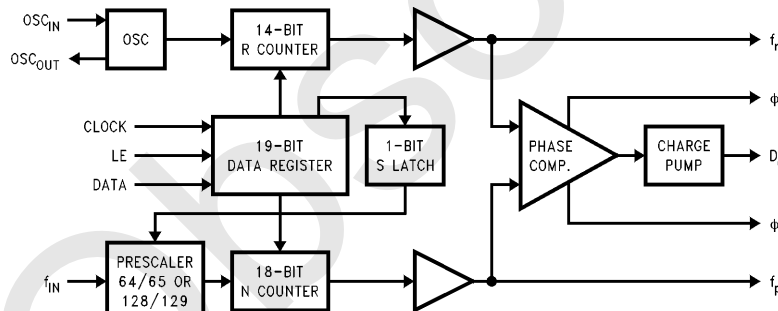

TL/W/12340-1

TRI-STATE® is a registered trademark of National Semiconductor Corporation.
MICROWIRE™ and PLLatinum™ are trademarks of National Semiconductor Corporation.

Connection Diagrams

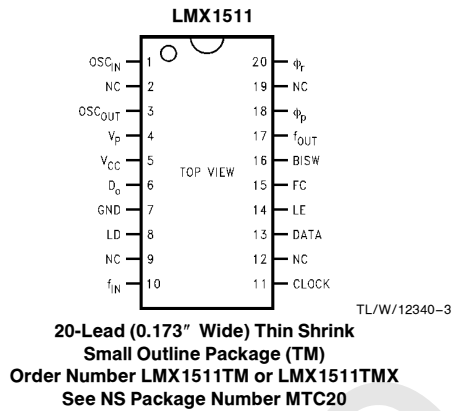
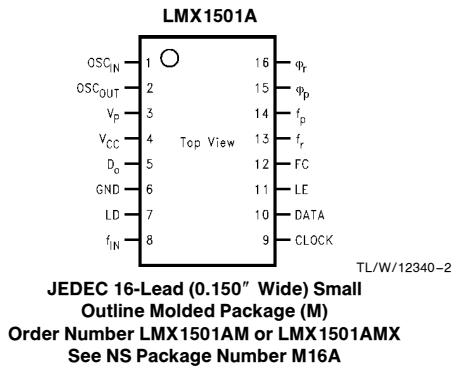

Pin Descriptions

Pin No.	Pin No.	Pin Name	I/O	Description
1501A	1511	1501A/1511		
1	1	OSC _{IN}	I	Oscillator input. A CMOS inverting gate input intended for connection to a crystal resonator for operation as an oscillator. The input has a $V_{CC}/2$ input threshold and can be driven from an external CMOS or TTL logic gate. May also be used as a buffer for an externally provided reference oscillator.
2	3	OSC _{OUT}	O	Oscillator output.
3	4	V _P		Power supply for charge pump must be $\geq V_{CC}$.
4	5	V _{CC}		Power supply voltage input. Input may range from 2.7V to 5.5V. Bypass capacitors should be placed as close as possible to this pin and be connected directly to the ground plane.
5	6	D _O	O	Internal charge pump output. For connection to a loop filter for driving the input of an external VCO.
6	7	GND		Ground.
7	8	LD	O	Lock detect. Output provided to indicate when the VCO frequency is in "lock". When the loop is locked, the pin's output is HIGH with narrow low pulses.
8	10	f _{IN}	I	Prescaler input. Small signal input from the VCO.
9	11	CLOCK	I	High impedance CMOS Clock input. Data is clocked in on the rising edge, into the various counters and registers.
10	13	DATA	I	Binary serial data input. Data entered MSB first. LSB is control bit. High impedance CMOS input.
11	14	LE	I	Load enable input (with internal pull-up resistor). When LE transitions HIGH, data stored in the shift registers is loaded into the appropriate latch (control bit dependent). Clock must be low when LE toggles high or low. See Serial Data Input Timing Diagram.
12	15	FC	I	Phase control select (with internal pull-up resistor). When FC is LOW, the polarity of the phase comparator and charge pump combination is reversed.
X	16	BISW	O	Analog switch output. When LE is HIGH, the analog switch is ON, routing the internal charge pump output through BISW (as well as through D _O).
13		f _r	O	Monitor pin of phase comparator input. Programmable reference divider output.
14		f _p	O	Monitor pin of phase comparator input. Programmable divider output.
X	17	f _{OUT}	O	Monitor pin of phase comparator input. CMOS Output.
15	18	φ _p	O	Output for external charge pump. φ _p is an open drain N-channel transistor and requires a pull-up resistor.
16	20	φ _r	O	Output for external charge pump. φ _r is a CMOS logic output.
X	2,9,12,19	NC		No connect.

Functional Block Diagram

LMX1501A

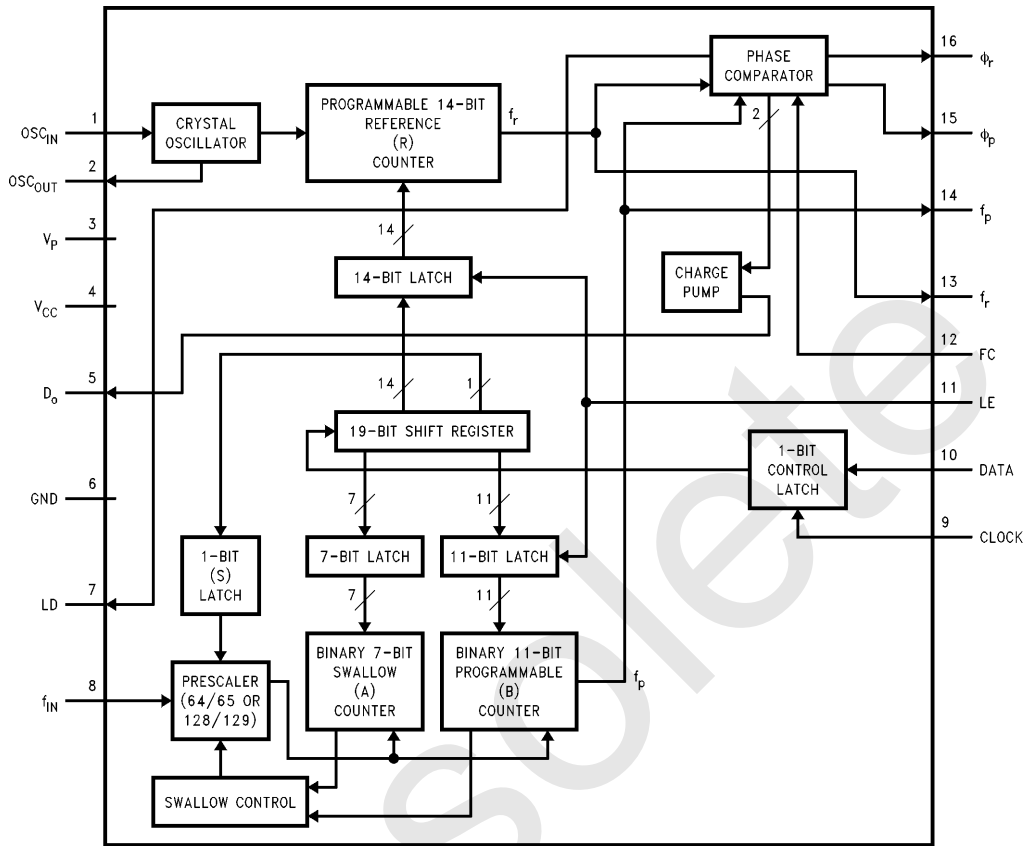

TL/W/12340-40

Functional Block Diagram (Continued)

LMX1511

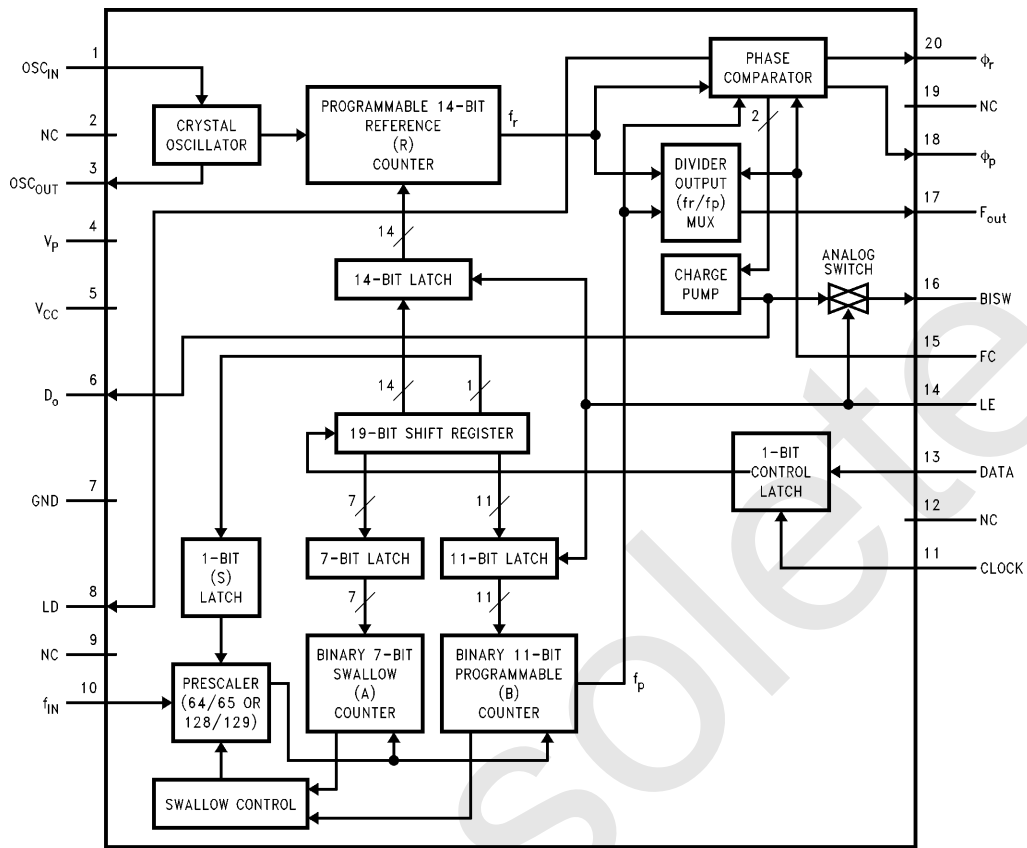

TL/W/12340-4

Absolute Maximum Ratings (Note 1)

If Military/Aerospace specified devices are required, please contact the National Semiconductor Sales Office/Distributors for availability and specifications.

Power Supply Voltage	
V_{CC}	-0.3V to +6.5V
V_P	-0.3V to +6.5V
Voltage on Any Pin with GND = 0V (V_I)	-0.3V to +6.5V
Storage Temperature Range (T_S)	-65°C to +150°C
Lead Temperature (T_L) (solder, 4 sec.)	+260°C

Recommended Operating Conditions

Power Supply Voltage	2.7V to 5.5V
V_{CC}	V_{CC} to 5.5V
V_P	
Operating Temperature (T_A)	-40°C to +85°C

Note 1: Absolute Maximum Ratings indicate limits beyond which damage to the device may occur. Operating Ratings indicate conditions for which the device is intended to be functional, but do not guarantee specific performance limits. For guaranteed specifications and test conditions, see the Electrical Characteristics. The guaranteed specifications apply only for the test conditions listed.

Electrical Characteristics $V_{CC} = 5.0V$, $V_P = 5.0V$; $-40^\circ C < T_A < 85^\circ C$, except as specified

Symbol	Parameter	Conditions	Min	Typ	Max	Units
I_{CC}	Power Supply Current	$V_{CC} = 3.0V$		6.0	8.0	mA
		$V_{CC} = 5.0V$		6.5	8.5	mA
f_{IN}	Maximum Operating Frequency		1.1			GHz
f_{OSC}	Maximum Oscillator Frequency		20			MHz
f_ϕ	Maximum Phase Detector Frequency		10			MHz
Pf_{IN}	Input Sensitivity	$V_{CC} = 2.7V$ to $5.5V$	-10		+6	dBm
V_{OSC}	Oscillator Sensitivity	OSC_{IN}	0.5			V_{PP}
V_{IH}	High-Level Input Voltage	*	$0.7 V_{CC}$			V
V_{IL}	Low-Level Input Voltage	*			$0.3 V_{CC}$	V
I_{IH}	High-Level Input Current (Clock, Data)	$V_{IH} = V_{CC} = 5.5V$	-1.0		1.0	μA
I_{IL}	Low-Level Input Current (Clock, Data)	$V_{IL} = 0V$, $V_{CC} = 5.5V$	-1.0		1.0	μA
I_{IH}	Oscillator Input Current	$V_{IH} = V_{CC} = 5.5V$			100	μA
		$V_{IL} = 0V$, $V_{CC} = 5.5V$	-100			μA
I_{IH}	High-Level Input Current (LE, FC)	$V_{IH} = V_{CC} = 5.5V$	-1.0		1.0	μA
I_{IL}	Low-Level Input Current (LE, FC)	$V_{IL} = 0V$, $V_{CC} = 5.5V$	-100		1.0	μA

*Except f_{IN} and OSC_{IN}

Electrical Characteristics $V_{CC} = 5.0V$, $V_P = 5.0V$; $-40^{\circ}C < T_A < 85^{\circ}C$, except as specified (Continued)

Symbol	Parameter	Conditions	Min	Typ	Max	Units
$I_{D_0\text{-source}}$	Charge Pump Output Current	$V_{D_0} = V_P/2$		-5.0		mA
$I_{D_0\text{-sink}}$		$V_{D_0} = V_P/2$		5.0		mA
$I_{D_0\text{-Tri}}$	Charge Pump TRI-STATE® Current	$0.5V \leq V_{D_0} \leq V_P - 0.5V$ $T = 25^{\circ}C$	-5.0		5.0	nA
V_{OH}	High-Level Output Voltage	$I_{OH} = -1.0\text{ mA}^{**}$	$V_{CC} - 0.8$			V
V_{OL}	Low-Level Output Voltage	$I_{OL} = 1.0\text{ mA}^{**}$			0.4	V
V_{OH}	High-Level Output Voltage (OSC _{OUT})	$I_{OH} = -200\ \mu A$	$V_{CC} - 0.8$			V
V_{OL}	Low-Level Output Voltage (OSC _{OUT})	$I_{OL} = 200\ \mu A$			0.4	V
I_{OL}	Open Drain Output Current (ϕ_P)	$V_{CC} = 5.0V$, $V_{OL} = 0.4V$	1.0			mA
I_{OH}	Open Drain Output Current (ϕ_P)	$V_{OH} = 5.5V$			100	μA
R_{ON}	Analog Switch ON Resistance (1511)			100		Ω
t_{CS}	Data to Clock Set Up Time	See Data Input Timing	50			ns
t_{CH}	Data to Clock Hold Time	See Data Input Timing	10			ns
t_{CWH}	Clock Pulse Width High	See Data Input Timing	50			ns
t_{CWL}	Clock Pulse Width Low	See Data Input Timing	50			ns
t_{ES}	Clock to Enable Set Up Time	See Data Input Timing	50			ns
t_{EW}	Enable Pulse Width	See Data Input Timing	50			ns

**Except OSC_{OUT}

Typical Performance Characteristics

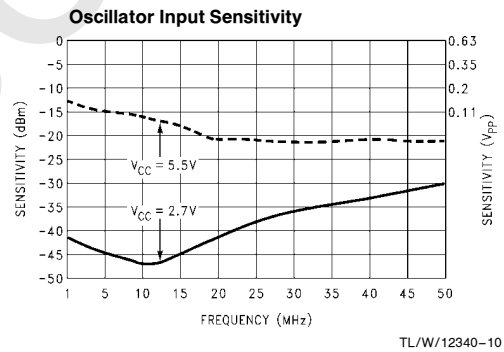
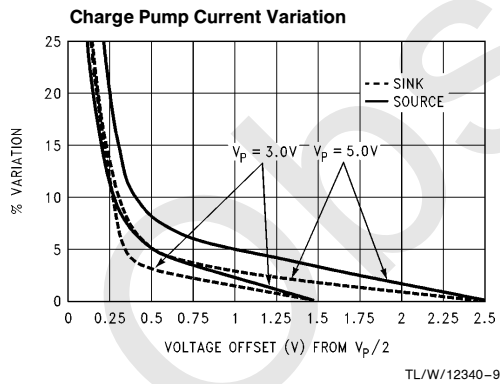
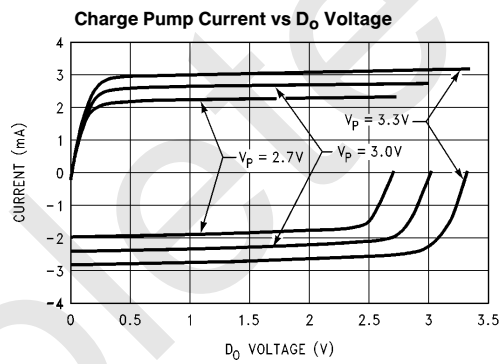
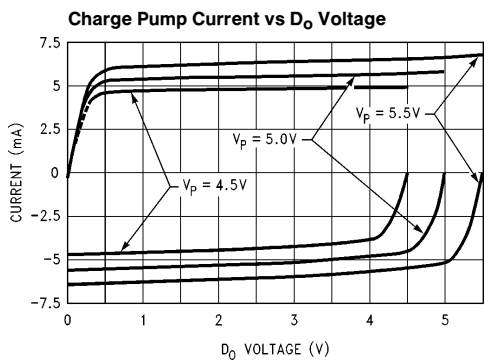
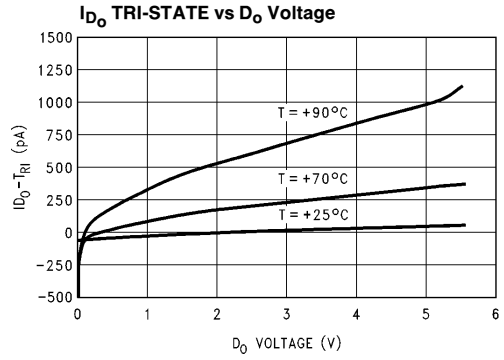
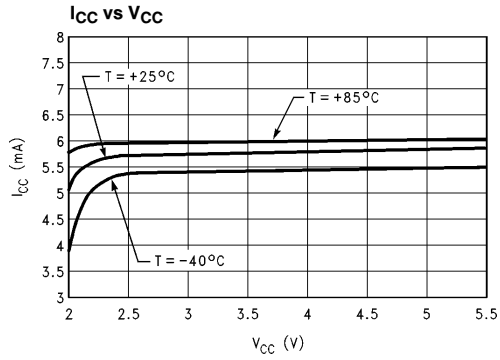

Typical Performance Characteristics (Continued)

Input Sensitivity vs Frequency

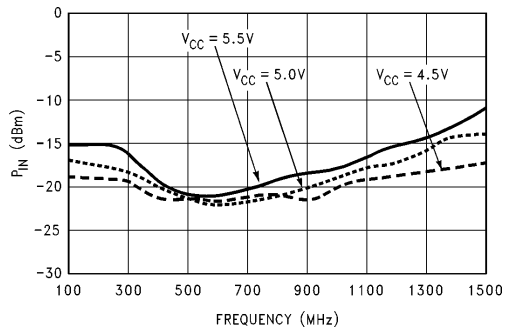

TL/W/12340-11

Input Sensitivity vs Frequency

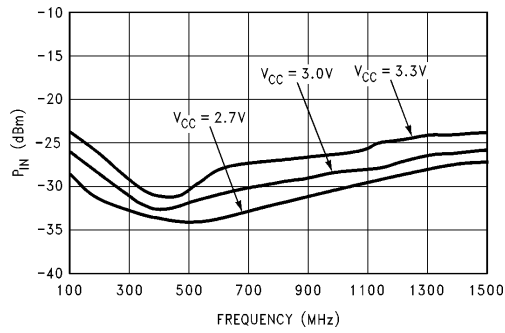

TL/W/12340-12

Input Sensitivity at Temperature Variation, $V_{CC} = 5V$

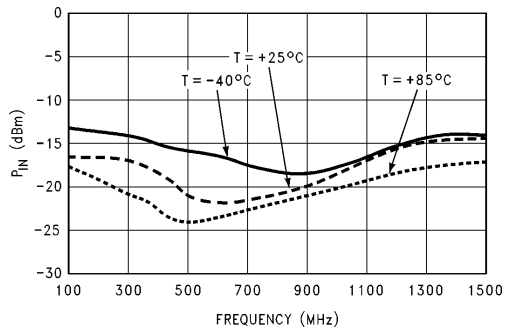

TL/W/12340-13

Input Sensitivity at Temperature Variation, $V_{CC} = 3V$

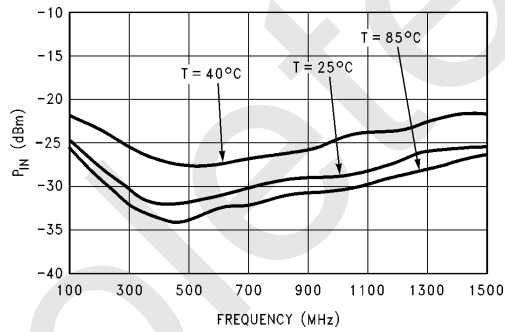

TL/W/12340-14

LMX1501A Input Impedance vs Frequency

$V_{CC} = 2.7V$ to $5.5V$, $f_{IN} = 100$ MHz to 1,600 MHz

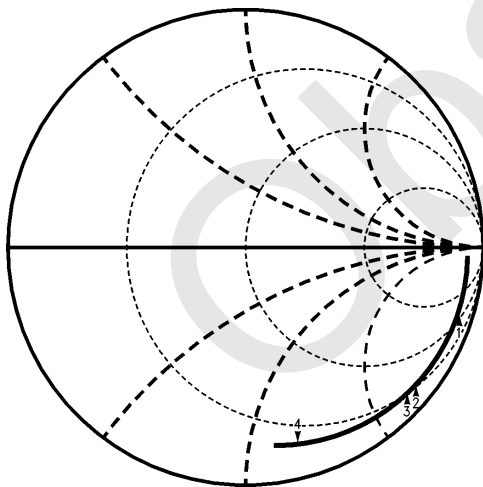

TL/W/12340-15

Marker 1 = 500 MHz, Real = 67, Imag. = -317
 Marker 2 = 900 MHz, Real = 24, Imag. = -150
 Marker 3 = 1 GHz, Real = 19, Imag. = -126
 Marker 4 = 1500 MHz, Real = 9, Imag. = -63

LMX1511 Input Impedance vs Frequency

$V_{CC} = 2.7V$ to $5.5V$, $f_{IN} = 100$ MHz to 1,600 MHz

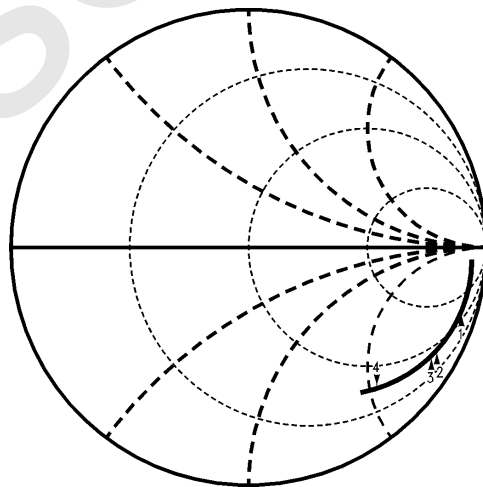

TL/W/12340-16

Marker 1 = 500 MHz, Real = 69, Imag. = -330
 Marker 2 = 900 MHz, Real = 36, Imag. = -193
 Marker 3 = 1 GHz, Real = 35, Imag. = -172
 Marker 4 = 1500 MHz, Real = 30, Imag. = -106

Charge Pump Current Specification Definitions

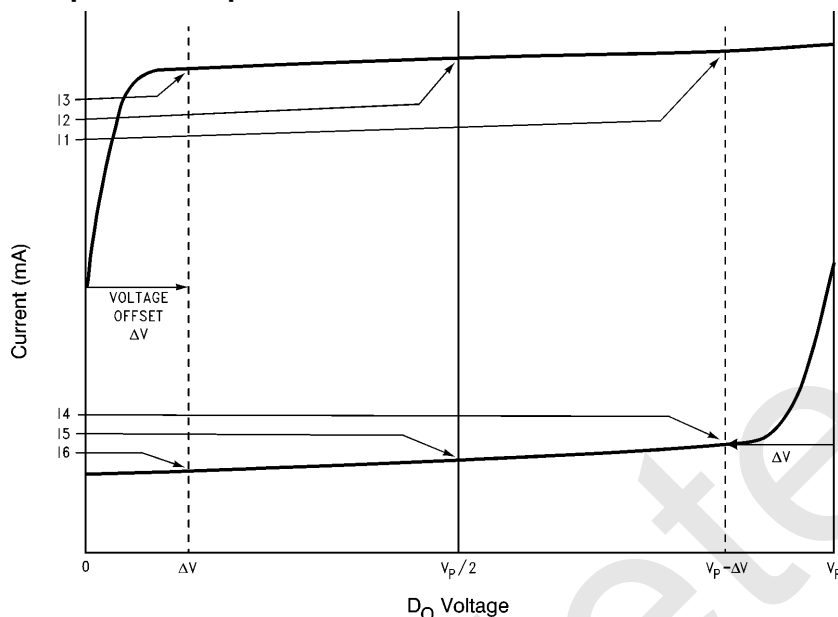

TL/W/12340-17

I1 = CP sink current at $V_{D_O} = V_P - \Delta V$

I4 = CP source current at $V_{D_O} = V_P - \Delta V$

I2 = CP sink current at $V_{D_O} = V_P/2$

I5 = CP source current at $V_{D_O} = V_P/2$

I3 = CP sink current at $V_{D_O} = \Delta V$

I6 = CP source current at $V_{D_O} = \Delta V$

ΔV = Voltage offset from positive and negative rails. Dependent on VCO tuning range relative to V_{CC} and ground. Typical values are between 0.5V and 1.0V.

- I_{D_O} vs V_{D_O} = Charge Pump Output Current magnitude variation vs Voltage = $[\frac{1}{2} * (|I1| - |I3|) / (\frac{1}{2} * (|I1| + |I3|))] * 100\%$ and $[\frac{1}{2} * (|I4| - |I6|) / (\frac{1}{2} * (|I4| + |I6|))] * 100\%$
- I_{D_O-sink} vs $I_{D_O-source}$ = Charge Pump Output Current Sink vs Source Mismatch = $(|I2| - |I5|) / (\frac{1}{2} * (|I2| + |I5|)) * 100\%$
- I_{D_O} vs T_A = Charge Pump Output Current magnitude variation vs Temperature = $(|I2 @ temp| - |I2 @ 25^\circ C|) / |I2 @ 25^\circ C| * 100\%$ and $(|I5 @ temp| - |I5 @ 25^\circ C|) / |I5 @ 25^\circ C| * 100\%$
- K_ϕ = Phase detector/charge pump gain constant = $\frac{1}{2} * (|I2| + |I5|)$

RF Sensitivity Test Block Diagram

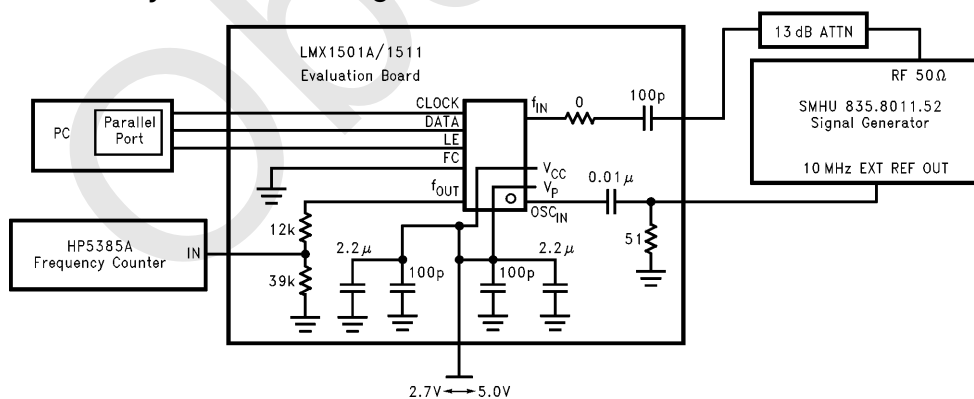

TL/W/12340-18

Note 1: N = 10,000 R = 50 P = 64

Note 2: Sensitivity limit is reached when the error of the divided RF output, f_{OUT} , is greater than or equal to 1 Hz.

Functional Description

The simplified block diagram below shows the 19-bit data register, the 14-bit R Counter and the S Latch, and the 18-bit N Counter (intermediate latches are not shown). The data stream is clocked (on the rising edge) into the DATA input, MSB first. If the Control Bit (last bit input) is HIGH, the DATA is transferred into the R Counter (programmable reference divider) and the S Latch (prescaler select: 64/65 or 128/129). If the Control Bit (LSB) is LOW, the DATA is transferred into the N Counter (programmable divider).

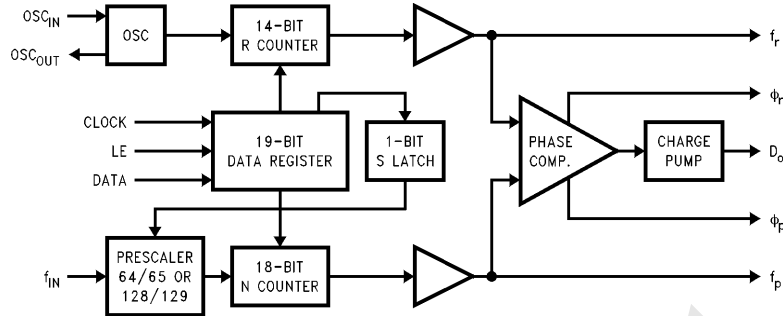

TL/W/12340-19

PROGRAMMABLE REFERENCE DIVIDER (R COUNTER) AND PRESCALER SELECT (S LATCH)

If the Control Bit (last bit shifted into the Data Register) is HIGH, data is transferred from the 19-bit shift register into a 14-bit latch (which sets the 14-bit R Counter) and the 1-bit S Latch (S15, which sets the prescaler: 64/65 or 128/129). Serial data format is shown below.

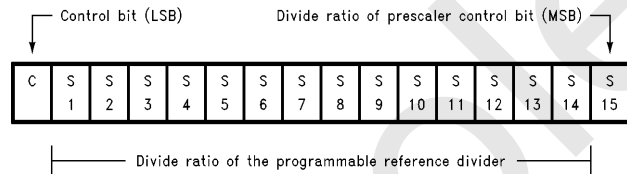

TL/W/12340-20

14-BIT PROGRAMMABLE REFERENCE DIVIDER RATIO (R COUNTER)

Divide Ratio R	S 14	S 13	S 12	S 11	S 10	S 9	S 8	S 7	S 6	S 5	S 4	S 3	S 2	S 1
3	0	0	0	0	0	0	0	0	0	0	0	0	1	1
4	0	0	0	0	0	0	0	0	0	0	0	1	0	0
•	•	•	•	•	•	•	•	•	•	•	•	•	•	•
16383	1	1	1	1	1	1	1	1	1	1	1	1	1	1

1-BIT PRESCALER SELECT (S LATCH)

Prescaler Select P	S 15
128/129	0
64/65	1

Notes: Divide ratios less than 3 are prohibited.

Divide ratio: 3 to 16383

S1 to S14: These bits select the divide ratio of the programmable reference divider.

C: Control bit (set to HIGH level to load R counter and S Latch)

Data is shifted in MSB first.

Functional Description (Continued)

PROGRAMMABLE DIVIDER (N COUNTER)

The N counter consists of the 7-bit swallow counter (A counter) and the 11-bit programmable counter (B counter). If the Control Bit (last bit shifted into the Data Register) is LOW, data is transferred from the 19-bit shift register into a 7-bit latch (which sets the 7-bit Swallow (A) Counter) and an 11-bit latch (which sets the 11-bit programmable (B) Counter). Serial data format is shown below.

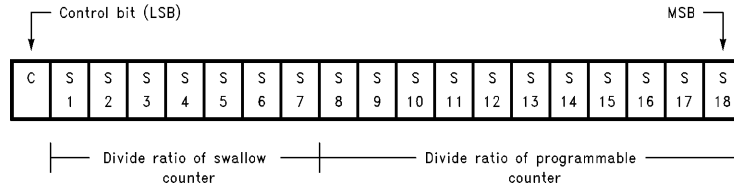

TL/W/12340-21

Note: S8 to S18: Programmable counter divide ratio control bits (3 to 2047)

7-BIT SWALLOW COUNTER DIVIDE RATIO (A COUNTER)

Divide Ratio A	S 7	S 6	S 5	S 4	S 3	S 2	S 1
0	0	0	0	0	0	0	0
1	0	0	0	0	0	0	1
•	•	•	•	•	•	•	•
127	1	1	1	1	1	1	1

Note: Divide ratio: 0 to 127
B ≥ A

11-BIT PROGRAMMABLE COUNTER DIVIDE RATIO (B COUNTER)

Divide Ratio B	S 18	S 17	S 16	S 15	S 14	S 13	S 12	S 11	S 10	S 9	S 8
3	0	0	0	0	0	0	0	0	0	1	1
4	0	0	0	0	0	0	0	0	1	0	0
•	•	•	•	•	•	•	•	•	•	•	•
2047	1	1	1	1	1	1	1	1	1	1	1

Note: Divide ratio: 3 to 2047 (Divide ratios less than 3 are prohibited)
B ≥ A

PULSE SWALLOW FUNCTION

$$f_{VCO} = [(P \times B) + A] \times f_{OSC} / R$$

f_{VCO} : Output frequency of external voltage controlled oscillator (VCO)

B: Preset divide ratio of binary 11-bit programmable counter (3 to 2047)

A: Preset divide ratio of binary 7-bit swallow counter (0 ≤ A ≤ 127, A ≤ B)

f_{OSC} : Output frequency of the external reference frequency oscillator

R: Preset divide ratio of binary 14-bit programmable reference counter (3 to 16383)

P: Preset modulus of dual modulus prescaler (64 or 128)

Functional Description (Continued)

SERIAL DATA INPUT TIMING

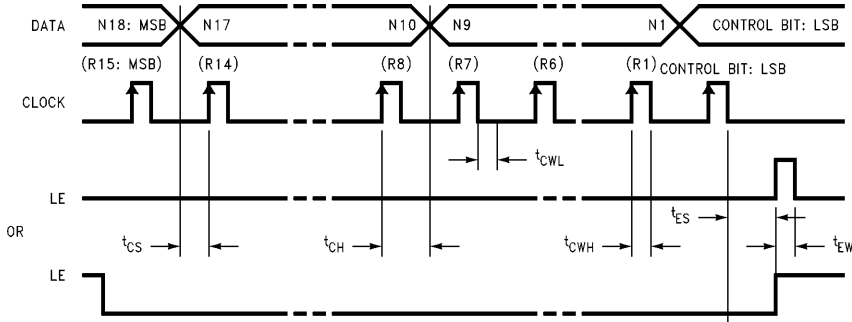

TL/W/12340-22

Notes: Parenthesis data indicates programmable reference divider data.

Data shifted into register on clock rising edge.

Data is shifted in MSB first.

Test Conditions: The Serial Data Input Timing is tested using a symmetrical waveform around $V_{CC}/2$. The test waveform has an edge rate of 0.6 V/ns with amplitudes of 2.2V @ $V_{CC} = 2.7V$ and 2.6V @ $V_{CC} = 5.5V$.

Phase Characteristics

In normal operation, the FC pin is used to reverse the polarity of the phase detector. Both the internal and any external charge pump are affected.

Depending upon VCO characteristics, FC pin should be set accordingly:

When VCO characteristics are like (1), FC should be set HIGH or OPEN CIRCUIT;

When VCO characteristics are like (2), FC should be set LOW.

When FC is set HIGH or OPEN CIRCUIT, the monitor pin of the phase comparator input, f_{out} , is set to the reference divider output, f_r . When FC is set LOW, f_{out} is set to the programmable divider output, f_p .

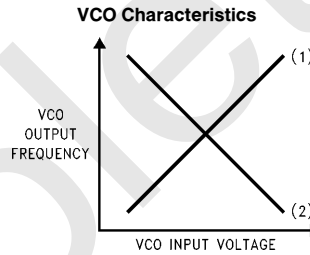

TL/W/12340-23

PHASE COMPARATOR AND INTERNAL CHARGE PUMP CHARACTERISTICS

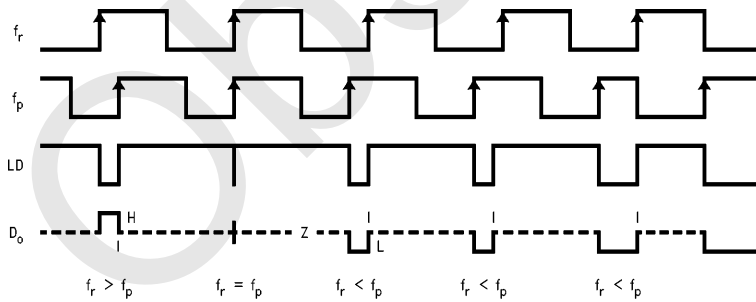

TL/W/12340-24

Notes: Phase difference detection range: -2π to $+2\pi$

The minimum width pump up and pump down current pulses occur at the D_o pin when the loop is locked.

FC = HIGH

Analog Switch (1511 only)

The analog switch is useful for radio systems that utilize a frequency scanning mode and a narrow band mode. The purpose of the analog switch is to decrease the loop filter time constant, allowing the VCO to adjust to its new frequency in a shorter amount of time. This is achieved by adding another filter stage in parallel. The output of the charge pump is normally through the D_o pin, but when LE is set HIGH, the charge pump output also becomes available at BISW. A typical circuit is shown below. The second filter stage (LPF-2) is effective only when the switch is closed (in the scanning mode).

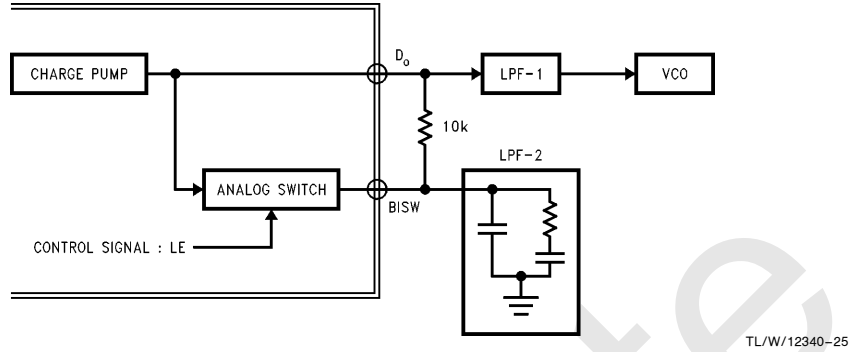

Typical Crystal Oscillator Circuit

A typical circuit which can be used to implement a crystal oscillator is shown below.

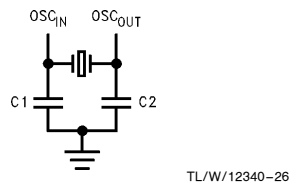

Typical Lock Detect Circuit

A lock detect circuit is needed in order to provide a steady LOW signal when the PLL is in the locked state. A typical circuit is shown below.

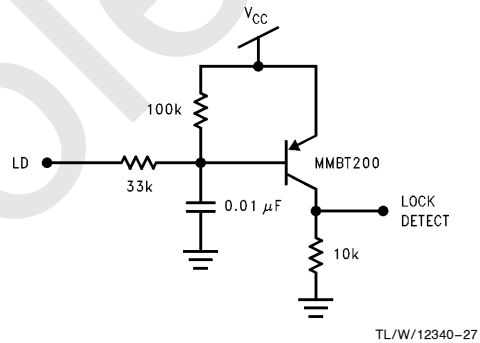

Typical Application Example

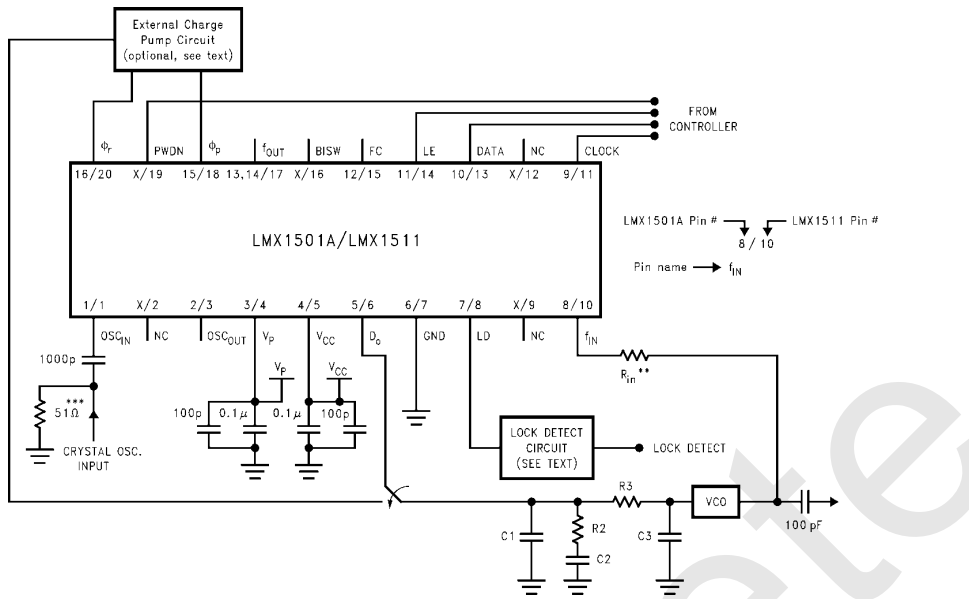

TL/W/12340-28

Operational Notes:

*VCO is assumed AC coupled.

** R_{IN} increases impedance so that VCO output power is provided to the load rather than the PLL. Typical values are 10Ω to 200Ω depending on the VCO power level. f_{IN} RF impedance ranges from 40Ω to 100Ω.

***50Ω termination is often used on test boards to allow use of external reference oscillator. For most typical products a CMOS clock is used and no terminating resistor is required. OSC_{IN} may be AC or DC coupled. AC coupling is recommended because the input circuit provides its own bias. (See Figure below)

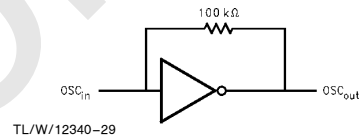

TL/W/12340-29

Proper use of grounds and bypass capacitors is essential to achieve a high level of performance.

Crosstalk between pins can be reduced by careful board layout.

This is a static sensitive device. It should be handled only at static free work stations.

Application Information

LOOP FILTER DESIGN

A block diagram of the basic phase locked loop is shown.

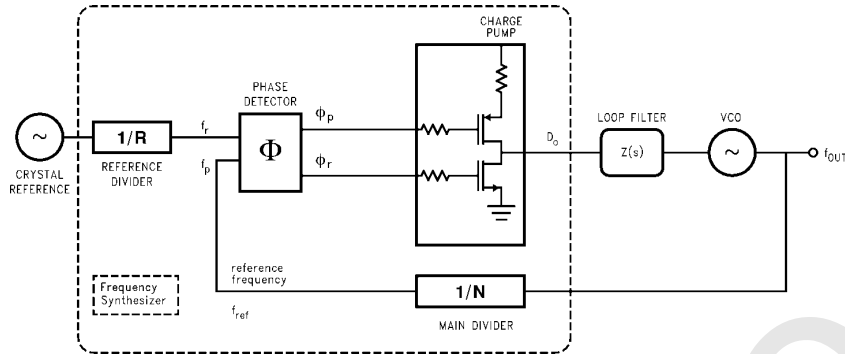
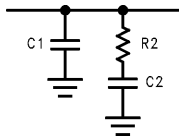

FIGURE 1. Basic Charge Pump Phase Locked Loop

TL/W/12340-30

An example of a passive loop filter configuration, including the transfer function of the loop filter, is shown in Figure 2.



TL/W/12340-31

$$Z(s) = \frac{s(C2 \cdot R2) + 1}{s^2(C1 \cdot C2 \cdot R2) + sC1 + sC2}$$

FIGURE 2. 2nd Order Passive Filter

Define the time constants which determine the pole and zero frequencies of the filter transfer function by letting

$$T2 = R2 \cdot C2 \quad (1a)$$

and

$$T1 = R2 \cdot \frac{C1 \cdot C2}{C1 + C2} \quad (1b)$$

The PLL linear model control circuit is shown along with the open loop transfer function in Figure 3. Using the phase detector and VCO gain constants [$K\phi$ and K_{VCO}] and the loop filter transfer function [$Z(s)$], the open loop Bode plot can be calculated. The loop bandwidth is shown on the Bode plot (ω_p) as the point of unity gain. The phase margin is shown to be the difference between the phase at the unity gain point and -180° .

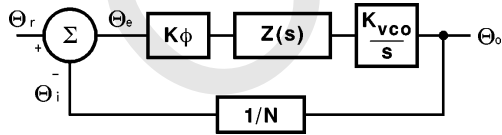

TL/W/12340-33

$$\begin{aligned} \text{Open Loop Gain} &= \theta_i / \theta_e = H(s) G(s) \\ &= K\phi Z(s) K_{VCO} / Ns \end{aligned}$$

$$\text{Closed Loop Gain} = \theta_o / \theta_i = G(s) / [1 + H(s) G(s)]$$

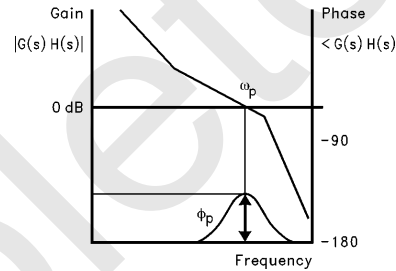

TL/W/12340-32

FIGURE 3. Open Loop Transfer Function

Thus we can calculate the 3rd order PLL Open Loop Gain in terms of frequency

$$G(s) \cdot H(s) \Big|_{s=j\omega} = \frac{-K\phi \cdot K_{VCO} (1 + j\omega \cdot T2)}{\omega^2 C1 \cdot N(1 + j\omega \cdot T1)} \cdot \frac{T1}{T2} \quad (2)$$

From equation 2 we can see that the phase term will be dependent on the single pole and zero such that

$$\phi(\omega) = \tan^{-1}(\omega \cdot T2) - \tan^{-1}(\omega \cdot T1) + 180^\circ \quad (3)$$

By setting

$$\frac{d\phi}{d\omega} = \frac{T2}{1 + (\omega \cdot T2)^2} - \frac{T1}{1 + (\omega \cdot T1)^2} = 0 \quad (4)$$

we find the frequency point corresponding to the phase inflection point in terms of the filter time constants T1 and T2. This relationship is given in equation 5.

$$\omega_p = 1 / \sqrt{T2 \cdot T1} \quad (5)$$

For the loop to be stable the unity gain point must occur before the phase reaches -180 degrees. We therefore want the phase margin to be at a maximum when the magnitude of the open loop gain equals 1. Equation 2 then gives

$$C1 = \frac{K\phi \cdot K_{VCO} \cdot T1}{\omega_p^2 \cdot N \cdot T2} \left\| \frac{(1 + j\omega_p \cdot T2)}{(1 + j\omega_p \cdot T1)} \right\| \quad (6)$$

Application Information (Continued)

Therefore, if we specify the loop bandwidth, ω_p , and the phase margin, ϕ_p , Equations 1 through 6 allow us to calculate the two time constants, T1 and T2, as shown in equations 7 and 8. A common rule of thumb is to begin your design with a 45° phase margin.

$$T1 = \frac{\sec\phi_p - \tan\phi_p}{\omega_p} \quad (7)$$

$$T2 = \frac{1}{\omega_p^2 \cdot T1} \quad (8)$$

From the time constants T1, and T2, and the loop bandwidth, ω_p , the values for C1, R2, and C2 are obtained in equations 9 to 11.

$$C1 = \frac{T1}{T2} \cdot \frac{K\phi \cdot K_{VCO}}{\omega_p^2 \cdot N} \sqrt{1 + (\omega_p \cdot T2)^2} \quad (9)$$

$$C2 = C1 \cdot \left(\frac{T2}{T1} - 1 \right) \quad (10)$$

$$R2 = \frac{T2}{C2} \quad (11)$$

K_{VCO} (MHz/V)	Voltage Controlled Oscillator (VCO) Tuning Voltage constant. The frequency vs voltage tuning ratio.
$K\phi$ (mA)	Phase detector/charge pump gain constant. The ratio of the current output to the input phase differential.
N	Main divider ratio. Equal to RF_{opt}/f_{ref}
RF_{opt} (MHz)	Radio Frequency output of the VCO at which the loop filter is optimized.
f_{ref} (kHz)	Frequency of the phase detector inputs. Usually equivalent to the RF channel spacing.

$$T2 = \frac{1}{\omega_c^2 \cdot (T1 + T3)} \quad (15)$$

$$\omega_c = \frac{\tan\phi \cdot (T1 + T3)}{[(T1 + T3)^2 + T1 \cdot T3]} \cdot \left[\sqrt{1 + \frac{(T1 + T3)^2 + T1 \cdot T3}{[\tan\phi \cdot (T1 + T3)]^2}} - 1 \right] \quad (16)$$

$$C1 = \frac{T1}{T2} \cdot \frac{K\phi \cdot K_{VCO}}{\omega_c^2 \cdot N} \cdot \left[\frac{(1 + \omega_c^2 \cdot T2^2)}{(1 + \omega_c^2 \cdot T1^2)(1 + \omega_c^2 \cdot T3^2)} \right]^{1/2} \quad (17)$$

In choosing the loop filter components a trade off must be made between lock time, noise, stability, and reference spurs. The greater the loop bandwidth the faster the lock time will be, but a large loop bandwidth could result in higher reference spurs. Wider loop bandwidths generally improve close in phase noise but may increase integrated phase noise depending on the reference input, VCO and division ratios used. The reference spurs can be reduced by reducing the loop bandwidth or by adding more low pass filter stages but the lock time will increase and stability will decrease as a result.

THIRD ORDER FILTER

A low pass filter section may be needed for some applications that require additional rejection of the reference sidebands, or spurs. This configuration is given in *Figure 4*. In order to compensate for the added low pass section, the component values are recalculated using the new open loop unity gain frequency. The degradation of phase margin caused by the added low pass is then mitigated by slightly increasing C1 and C2 while slightly decreasing R2.

The added attenuation from the low pass filter is:

$$ATTEN = 20 \log[(2\pi f_{ref} \cdot R3 \cdot C3)^2 + 1] \quad (12)$$

Defining the additional time constant as

$$T3 = R3 \cdot C3 \quad (13)$$

Then in terms of the attenuation of the reference spurs added by the low pass pole we have

$$T3 = \sqrt{\frac{10^{ATTEN/20} - 1}{(2\pi \cdot f_{ref})^2}} \quad (14)$$

We then use the calculated value for loop bandwidth ω_c in equation 11, to determine the loop filter component values in equations 15–17. ω_c is slightly less than ω_p , therefore the frequency jump lock time will increase.

Application Information (Continued)

Example #1

$$K_{VCO} = 19.3 \text{ MHz/V}$$

$$K_{\phi} = 5 \text{ mA (Note 1)}$$

$$RF_{opt} = 886 \text{ MHz}$$

$$F_{ref} = 25 \text{ kHz}$$

$$N = RF_{opt}/f_{ref} = 35440$$

$$\omega_p = 2\pi * 5 \text{ kHz} = 3.1415e4$$

$$\phi_p = 43^\circ$$

$$ATTEN = 10 \text{ dB}$$

$$T1 = \frac{\sec\phi_p - \tan\phi_p}{\omega_p} = 1.38e-5$$

$$T3 = \sqrt{\frac{10^{(10/20)} - 1}{(2\pi * 25e3)^2}} = 9.361e-6$$

$$\omega_c = \frac{(\tan 43^\circ) * (1.38e-5 + 9.361e-6)}{[(1.38e-5 + 9.361e-6)^2 + 1.38e-5 * 9.361e-6]}$$

$$\cdot \left[\sqrt{1 + \frac{(1.38e-5 + 9.361e-6)^2 + 1.38e-5 * 9.361e-6}{[(\tan 43^\circ) * (1.38e-5 + 9.361e-6)]^2}} - 1 \right]$$

$$= 1.8101e4$$

$$T2 = \frac{1}{(1.8101e4)^2 * (1.38e-5 + 9.361e-6)} = 1.318e-4$$

$$C1 = \frac{1.38e-5}{1.318e-4} \frac{(5e-3) * 19.3e6}{(1.8101e4)^2 * (35440)} \cdot \left[\frac{[1 + (1.8101e4)^2 * (1.318e-4)^2]}{[1 + (1.8101e4)^2 * (1.38e-5)^2] [1 + (1.8101e4)^2 * (9.361e-6)^2]} \right]^{1/2}$$

$$= 2.153 \text{ nF}$$

$$C2 = 2.153 \text{ nF} \left(\frac{1.318e-4}{1.38e-5} - 1 \right) = 18.35 \text{ nF}$$

$$R2 = \frac{1.318e-4}{18.35e-9} = 7.18 \text{ k}\Omega$$

if we choose $R3 = 120\text{k}$; then $C3 = \frac{9.361e-6}{120e3} = 78 \text{ pF}$.

Converting to standard component values gives the following filter values, which are shown in *Figure 4*.

$$C1 = 2200 \text{ pF}$$

$$R2 = 8.2 \text{ k}\Omega$$

$$C2 = 0.018 \text{ }\mu\text{F}$$

$$R3 = 120 \text{ k}\Omega$$

$$C3 = 78 \text{ pF}$$

Note 1: See related equation for K_{ϕ} in Charge Pump Current Specification Definitions. For this example $V_p = 5.0\text{V}$. The value for K_{ϕ} can then be approximated using the curves in the Typical Performance Characteristics for Charge Pump Current vs D_0 Voltage. The units for K_{ϕ} are in mA. You may also use $K_{\phi} = (5 \text{ mA}/2\pi \text{ rad})$, but in this case you must convert K_{VCO} to (rad/V) multiplying by 2π .

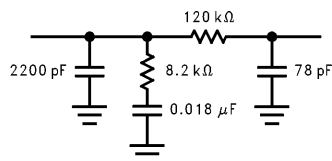

FIGURE 4. ~5 kHz Loop Filter

TL/W/12340-41

Application Information (Continued)

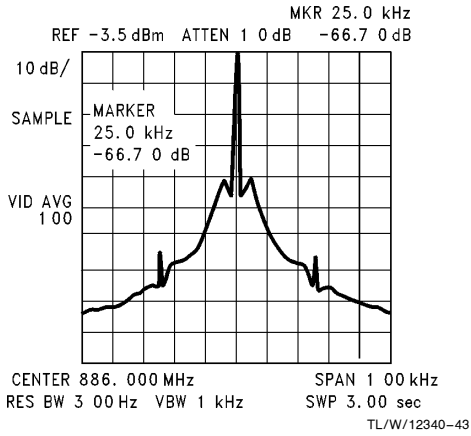

FIGURE 5. PLL Reference Spurs

The reference spurious level is < -66 dBc, due to the loop filter attenuation and the low spurious noise level of the LMX1511.

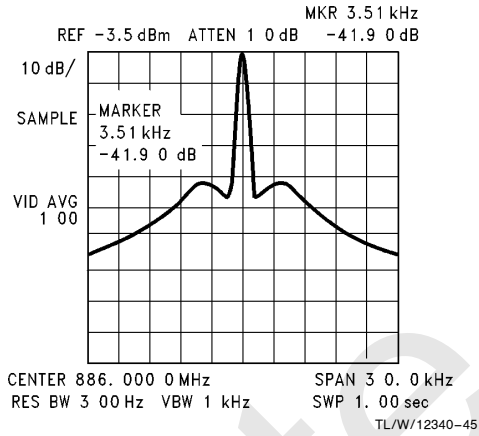

FIGURE 6. PLL Phase Noise 3.5 kHz Offset

The phase noise level at 3 kHz offset is -65 dBc/Hz.

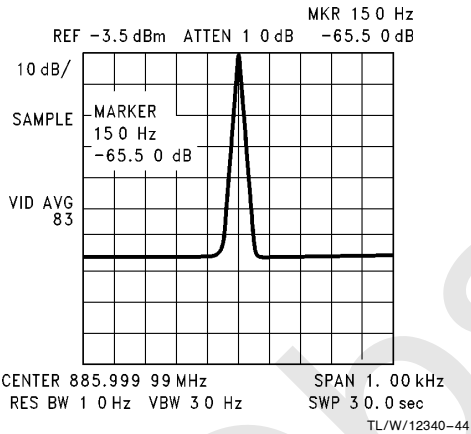

FIGURE 7. PLL Phase Noise @ 150 Hz Offset

The phase noise level at 150 Hz offset is -75.5 dBc/Hz.

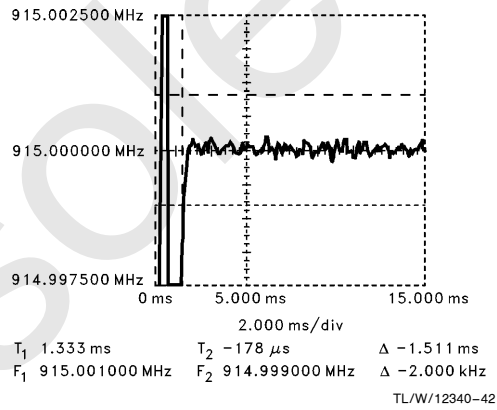

FIGURE 8. Frequency Jump Lock Time

Of concern in any PLL loop filter design is the time it takes to lock in to a new frequency when switching channels. *Figure 8* shows the switching waveforms for a frequency jump of 857 MHz–915 MHz. By narrowing the frequency span of the HP53310A Modulation Domain Analyzer enables evaluation of the frequency lock time to within ± 1 kHz. The lock time is seen to be < 1.6 ms for a frequency jump of 58 MHz.

Application Information (Continued)

EXTERNAL CHARGE PUMP

The LMX PLLatinum series of frequency synthesizers are equipped with an internal balanced charge pump as well as outputs for driving an external charge pump. Although the superior performance of NSC's on board charge pump eliminates the need for an external charge pump in most applications, certain system requirements are more stringent. In these cases, using an external charge pump allows the designer to take direct control of such parameters as charge pump voltage swing, current magnitude, TRI-STATE leakage, and temperature compensation.

One possible architecture for an external charge pump current source is shown in *Figure 9*. The signals ϕ_p and ϕ_r in the diagram, correspond to the phase detector outputs of the LMX1501/1511 frequency synthesizers. These logic signals are converted into current pulses, using the circuitry shown in *Figure 9*, to enable either charging or discharging of the loop filter components to control the output frequency of the PLL.

Referring to *Figure 9*, the design goal is to generate a 5 mA current which is relatively constant to within 5V of the power supply rail. To accomplish this, it is important to establish as large a voltage drop across R5, R8 as possible without saturating Q2, Q4. A voltage of approximately 300 mV provides a good compromise. This allows the current source reference being generated to be relatively repeatable in the absence of good Q1, Q2/Q3, Q4 matching. (Matched transistor pairs is recommended.) The ϕ_p and ϕ_r outputs are rated for a maximum output load current of 1 mA while 5 mA current sources are desired. The voltages developed across R4, 9 will consequently be approximately 258 mV, or 42 mV < R8, 5, due to the current density differences $\{0.026 \cdot 1n(5 \text{ mA}/1 \text{ mA})\}$ through the Q1, Q2/Q3, Q4 pairs.

In order to calculate the value of R7 it is necessary to first estimate the forward base to emitter voltage drop ($V_{fn,p}$) of the transistors used, the V_{OL} drop of ϕ_p , and the V_{OH} drop of ϕ_r 's under 1 mA loads. (ϕ_p 's $V_{OL} < 0.1V$ and ϕ_r 's $V_{OH} < 0.1V$.)

Knowing these parameters along with the desired current allow us to design a simple external charge pump. Separating the pump up and pump down circuits facilitates the nodal analysis and give the following equations.

$$R_4 = \frac{V_{R5} - V_T \cdot 1n\left(\frac{i_{source}}{i_{pmax}}\right)}{i_{source}}$$

$$R_9 = \frac{V_{R8} - V_T \cdot 1n\left(\frac{i_{sink}}{i_{nmax}}\right)}{i_{sink}}$$

$$R_5 = \frac{V_{R5} \cdot (\beta_p + 1)}{i_{pmax} \cdot (\beta_p + 1) - i_{source}}$$

$$R_8 = \frac{V_{R8} \cdot (\beta_n + 1)}{i_{rmax} \cdot (\beta_n + 1) - i_{sink}}$$

$$R_6 = \frac{(V_p - V_{VOL\phi_p}) - (V_{R5} + V_{fp})}{i_{pmax}}$$

$$R_7 = \frac{(V_p - V_{VOH\phi_r}) - (V_{R8} + V_{fn})}{i_{max}}$$

EXAMPLE

Typical Device Parameters $\beta_n = 100, \beta_p = 50$

Typical System Parameters $V_p = 5.0V;$

$V_{cntl} = 0.5V - 4.5V;$

$V_{\phi p} = 0.0V, V_{\phi r} = 5.0V$

Design Parameters

$I_{SINK} = I_{SOURCE} = 5.0 \text{ mA};$

$V_{fn} = V_{fp} = 0.8V$

$I_{rmax} = I_{pmax} = 1 \text{ mA}$

$V_{R8} = V_{R5} = 0.3V$

$V_{OL\phi p} = V_{OH\phi r} = 100 \text{ mV}$

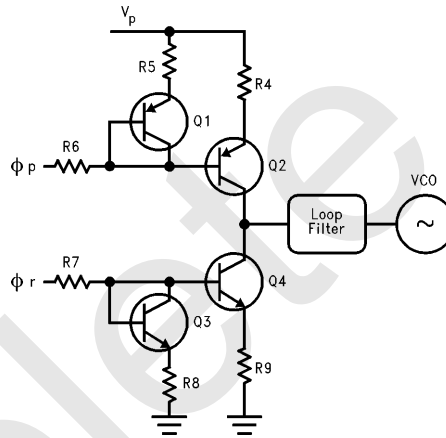

FIGURE 9

TL/W/12340-46

Therefore select

$$R_4 = R_9 = \frac{0.3V - 0.026 \cdot 1n(5.0 \text{ mA}/1.0 \text{ mA})}{5 \text{ mA}} = 51.6\Omega$$

$$R_5 = \frac{0.3V \cdot (50 + 1)}{1.0 \text{ mA} \cdot (50 + 1) - 5.0 \text{ mA}} = 332\Omega$$

$$R_8 = \frac{0.3V \cdot (100 + 1)}{1.0 \text{ mA} \cdot (100 + 1) - 5.0 \text{ mA}} = 315.6\Omega$$

$$R_6 = R_7 = \frac{(5V - 0.1V) - (0.3V + 0.8V)}{1.0 \text{ mA}} = 3.8 \text{ k}\Omega$$

Obsolete

Physical Dimensions inches (millimeters)

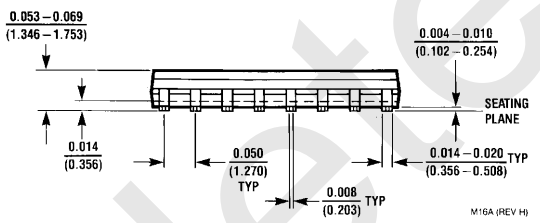
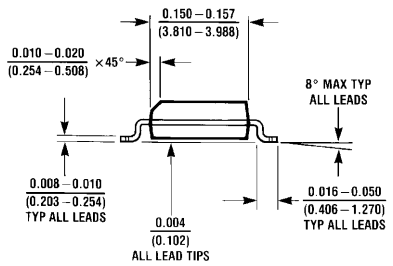
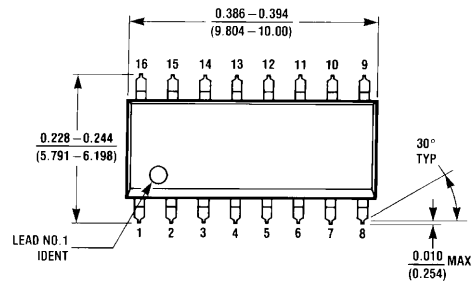

JEDEC 16-Lead (0.150" Wide) Small Outline Molded Package (M)
Order Number LMX1501AM
For Tape and Reel Order Number LMX1501AMX (2500 Units per Reel)
NS Package Number M16A

LMX1501A/LMX1511 PLLatinum 1.1 GHz Frequency Synthesizer for RF Personal Communications

Physical Dimensions (millimeters) (Continued)

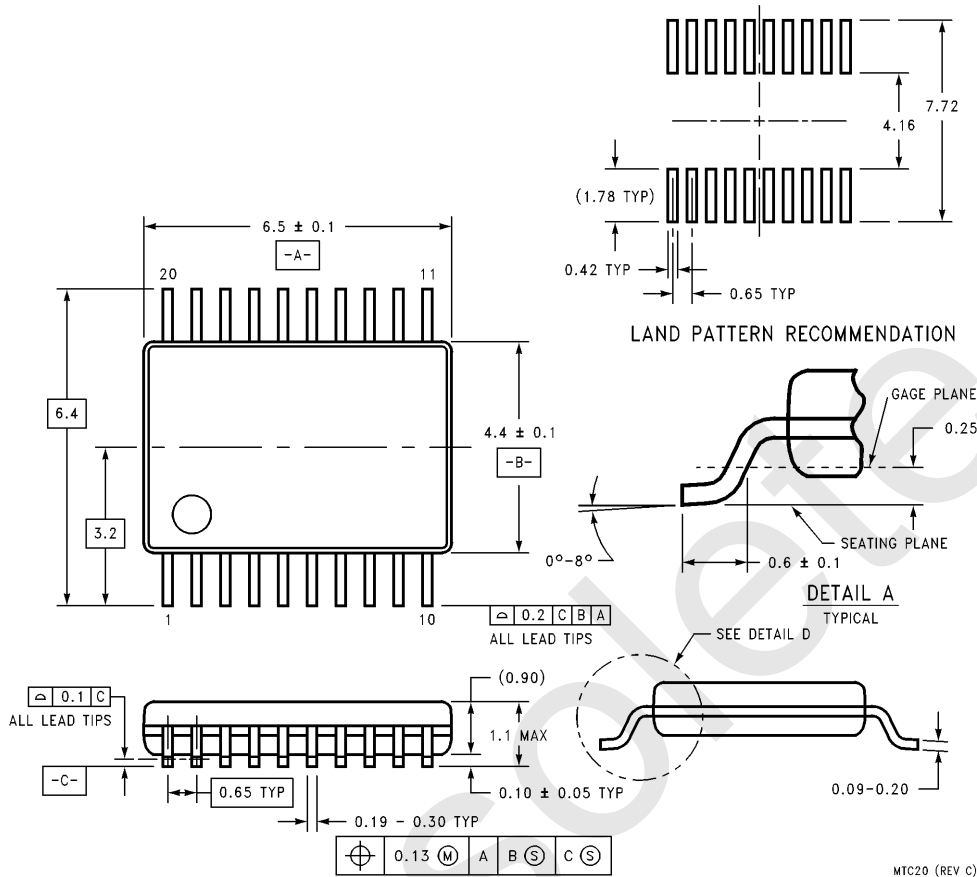

20-Lead (0.173" Wide) Thin Shrink Small Outline Package (TM)
Order Number LMX1511TM
For Tape and Reel Order Number LMX1511TMX (2500 Units per Reel)
NS Package Number MTC20

LIFE SUPPORT POLICY

NATIONAL'S PRODUCTS ARE NOT AUTHORIZED FOR USE AS CRITICAL COMPONENTS IN LIFE SUPPORT DEVICES OR SYSTEMS WITHOUT THE EXPRESS WRITTEN APPROVAL OF THE PRESIDENT OF NATIONAL SEMICONDUCTOR CORPORATION. As used herein:

1. Life support devices or systems are devices or systems which, (a) are intended for surgical implant into the body, or (b) support or sustain life, and whose failure to perform, when properly used in accordance with instructions for use provided in the labeling, can be reasonably expected to result in a significant injury to the user.
2. A critical component is any component of a life support device or system whose failure to perform can be reasonably expected to cause the failure of the life support device or system, or to affect its safety or effectiveness.



National Semiconductor Corporation
 1111 West Bardin Road
 Arlington, TX 76017
 Tel: 1(800) 272-9959
 Fax: 1(800) 737-7018

National Semiconductor Europe
 Fax: (+49) 0-180-530 85 86
 Email: onjwge@tevm2.nsc.com
 Deutsch Tel: (+49) 0-180-530 85 85
 English Tel: (+49) 0-180-532 78 32
 Français Tel: (+49) 0-180-532 93 58
 Italiano Tel: (+49) 0-180-534 16 80

National Semiconductor Hong Kong Ltd.
 19th Floor, Straight Block,
 Ocean Centre, 5 Canton Rd.
 Tsimshatsui, Kowloon
 Hong Kong
 Tel: (852) 2737-1600
 Fax: (852) 2736-9960

National Semiconductor Japan Ltd.
 Tel: 81-043-299-2309
 Fax: 81-043-299-2408

National does not assume any responsibility for use of any circuitry described, no circuit patent licenses are implied and National reserves the right at any time without notice to change said circuitry and specifications.

IMPORTANT NOTICE

Texas Instruments Incorporated and its subsidiaries (TI) reserve the right to make corrections, modifications, enhancements, improvements, and other changes to its products and services at any time and to discontinue any product or service without notice. Customers should obtain the latest relevant information before placing orders and should verify that such information is current and complete. All products are sold subject to TI's terms and conditions of sale supplied at the time of order acknowledgment.

TI warrants performance of its hardware products to the specifications applicable at the time of sale in accordance with TI's standard warranty. Testing and other quality control techniques are used to the extent TI deems necessary to support this warranty. Except where mandated by government requirements, testing of all parameters of each product is not necessarily performed.

TI assumes no liability for applications assistance or customer product design. Customers are responsible for their products and applications using TI components. To minimize the risks associated with customer products and applications, customers should provide adequate design and operating safeguards.

TI does not warrant or represent that any license, either express or implied, is granted under any TI patent right, copyright, mask work right, or other TI intellectual property right relating to any combination, machine, or process in which TI products or services are used. Information published by TI regarding third-party products or services does not constitute a license from TI to use such products or services or a warranty or endorsement thereof. Use of such information may require a license from a third party under the patents or other intellectual property of the third party, or a license from TI under the patents or other intellectual property of TI.

Reproduction of TI information in TI data books or data sheets is permissible only if reproduction is without alteration and is accompanied by all associated warranties, conditions, limitations, and notices. Reproduction of this information with alteration is an unfair and deceptive business practice. TI is not responsible or liable for such altered documentation. Information of third parties may be subject to additional restrictions.

Resale of TI products or services with statements different from or beyond the parameters stated by TI for that product or service voids all express and any implied warranties for the associated TI product or service and is an unfair and deceptive business practice. TI is not responsible or liable for any such statements.

TI products are not authorized for use in safety-critical applications (such as life support) where a failure of the TI product would reasonably be expected to cause severe personal injury or death, unless officers of the parties have executed an agreement specifically governing such use. Buyers represent that they have all necessary expertise in the safety and regulatory ramifications of their applications, and acknowledge and agree that they are solely responsible for all legal, regulatory and safety-related requirements concerning their products and any use of TI products in such safety-critical applications, notwithstanding any applications-related information or support that may be provided by TI. Further, Buyers must fully indemnify TI and its representatives against any damages arising out of the use of TI products in such safety-critical applications.

TI products are neither designed nor intended for use in military/aerospace applications or environments unless the TI products are specifically designated by TI as military-grade or "enhanced plastic." Only products designated by TI as military-grade meet military specifications. Buyers acknowledge and agree that any such use of TI products which TI has not designated as military-grade is solely at the Buyer's risk, and that they are solely responsible for compliance with all legal and regulatory requirements in connection with such use.

TI products are neither designed nor intended for use in automotive applications or environments unless the specific TI products are designated by TI as compliant with ISO/TS 16949 requirements. Buyers acknowledge and agree that, if they use any non-designated products in automotive applications, TI will not be responsible for any failure to meet such requirements.

Following are URLs where you can obtain information on other Texas Instruments products and application solutions:

Products

Audio	www.ti.com/audio
Amplifiers	amplifier.ti.com
Data Converters	dataconverter.ti.com
DLP® Products	www.dlp.com
DSP	dsp.ti.com
Clocks and Timers	www.ti.com/clocks
Interface	interface.ti.com
Logic	logic.ti.com
Power Mgmt	power.ti.com
Microcontrollers	microcontroller.ti.com
RFID	www.ti-rfid.com
OMAP Mobile Processors	www.ti.com/omap
Wireless Connectivity	www.ti.com/wirelessconnectivity

Applications

Communications and Telecom	www.ti.com/communications
Computers and Peripherals	www.ti.com/computers
Consumer Electronics	www.ti.com/consumer-apps
Energy and Lighting	www.ti.com/energy
Industrial	www.ti.com/industrial
Medical	www.ti.com/medical
Security	www.ti.com/security
Space, Avionics and Defense	www.ti.com/space-avionics-defense
Transportation and Automotive	www.ti.com/automotive
Video and Imaging	www.ti.com/video

TI E2E Community Home Page

e2e.ti.com

Mailing Address: Texas Instruments, Post Office Box 655303, Dallas, Texas 75265
Copyright © 2011, Texas Instruments Incorporated