

CLC109

CLC109 Low Power, Wideband, Closed Loop Buffer



Literature Number: SNOS814

CLC109

Low-Power, Wideband, Closed-Loop Buffer

General Description

The CLC109 is a high-performance, closed-loop monolithic buffer intended for power sensitive applications. Requiring only 35mW of quiescent power ($\pm 5V$ supplies), the CLC109 offers a high bandwidth of 270MHz (0.5V_{pp}) and a slew rate of 350V/ μ s. Even with this minimal dissipation, the CLC109 can easily drive a demanding 100 Ω load. The buffer specifications are for a 100 Ω load.

With its patented closed-loop topology, the CLC109 has significant performance advantages over conventional open-loop designs. Applications requiring low (2.8 Ω) output impedance and nearly ideal unity gain (0.997) through very high frequencies will benefit from the CLC109's superior performance. Power sensitive applications will benefit from the CLC109's excellent performance on reduced or single supply voltages.

Constructed using an advanced, complementary bipolar process and Comlinear's proven high-performance architectures, the CLC109 is available in several versions to meet a variety of requirements.

CLC109AJP	-40°C to +85°C	8-pin Plastic DIP
CLC109AJE	-40°C to +85°C	8-pin Plastic SOIC
CLC109ALC	-40°C to +85°C	dice
CLC109AMC	-55°C to +125°C	dice qualified to Method 5008, MIL-STD-883, Level B
CLC109AJM5	-40°C to +85°C	5-pin SOT

Contact factory for other packages and DESC SMD number.

Features

- High small-signal bandwidth (270MHz)
- Low supply current (3.5mA @ $\pm 5V$)
- Low output impedance (2.8 Ω)
- 350V/ μ s slew rate
- Single supply operation (0 to 3V supply min.)
- Evaluation boards and Spice models

Applications

- Video switch buffers
- Test point drivers
- Low power active filters
- DC clamping buffer
- High-speed S & H circuits
- Inverting op amp input buffer

Frequency Response for $\pm 5V$

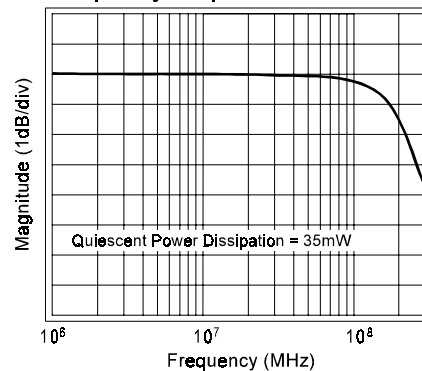

PINOUT
SOT23-5

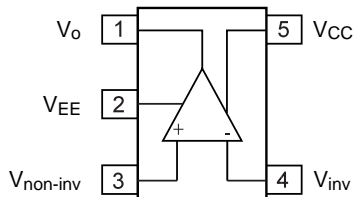

PINOUT
DIP & SOIC

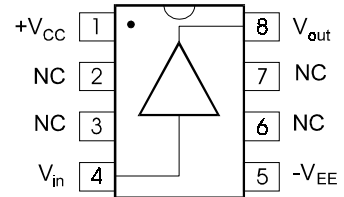

Pulse Response

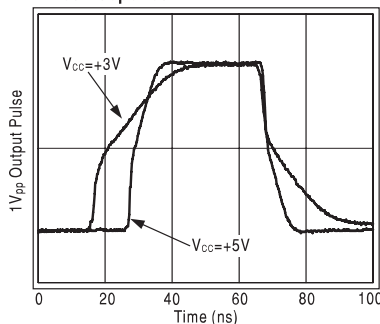

Typical Application

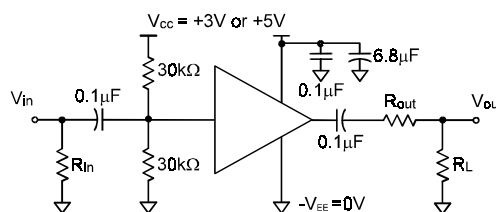

Single-Supply Circuit

Small-Signal Bandwidth

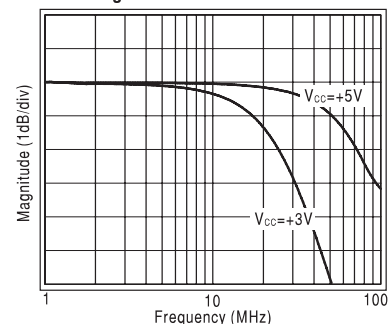

CLC109 Electrical Characteristics ($\pm V_{CC} = \pm 5V$, $R_L = 100\Omega$ unless specified)

PARAMETER	CONDITIONS	TYP	MIN/MAX RATINGS			UNITS	SYMBOL
Ambient Temperature	CLC109AJ	+25°C	-40°C	+25°C	+85°C		
FREQUENCY RESPONSE							
small signal bandwidth	$V_{out} < 0.5V_{pp}$	270	200	200	150	MHz	SSBW
	$V_{out} < 2.0V_{pp}$	120	90	90	70	MHz	LSBW
gain flatness	$V_{out} < 0.5V_{pp}$						
flatness	DC-30MHz	0	± 0.1	± 0.1	± 0.1	dB	GFL
peaking	DC-200MHz	0	1.0	0.3	0.3	dB	GFPH
rolloff	DC-60MHz	0.1	0.4	0.4	0.6	dB	GFRH
differential gain	4.43MHz, 150 Ω load	0.7	1.5	1.0	1.0	%	DG
differential phase	4.43MHz, 150 Ω load	0.03	0.05	0.05	0.1	°	DP
TIME DOMAIN RESPONSE							
rise and fall time	0.5V step	1.3	1.7	1.7	2.3	ns	TRS
	2.0V step	4.4	6	6	7	ns	TRL
settling time to $\pm 0.05\%$	2.0V step	12	25	18	25	ns	TS
overshoot	0.5V step	3	15	10	10	%	OS1
slew rate	4V step	350	220	250	220	V/ μ sec	SR
DISTORTION AND NOISE PERFORMANCE							
2nd harmonic distortion	$2V_{pp}$, 20MHz	-46	-36	-38	-38	dBc	HD2
3rd harmonic distortion	$2V_{pp}$, 20MHz	-55	-50	-50	-45	dBc	HD3
equivalent output noise							
voltage		3.3	4.1	4.1	4.5	nV/ $\sqrt{\text{Hz}}$	VN
current		1.3	3	2	2	pA/ $\sqrt{\text{Hz}}$	ICN
STATIC DC PERFORMANCE							
small signal gain	no load	0.997	0.995	0.995	0.994	V/V	GA1
	100 Ω load	0.96	0.94	0.95	0.95	V/V	GA2
output resistance	DC	2.8	5.0	4.0	4.0	Ω	RO
*output offset voltage		1	± 8.2	± 5	± 6	mV	VIO
average temperature coefficient		± 10	± 40		± 30	$\mu\text{V}/^\circ\text{C}$	DVIO
*input bias current		± 2	± 8	± 4	± 4	μA	IBN
average temperature coefficient		± 30	± 50		± 25	nA/ $^\circ\text{C}$	DIBN
power supply rejection ratio		-56	-48	-48	-46	dB	PSRR
*supply current	no load	3.5	4	4	4	mA	ICC
MISCELLANEOUS PERFORMANCE							
integral endpoint linearity	$\pm 1V$, full scale	0.5	1.0	0.7	0.6	%	ILIN
input resistance		1.5	0.3	1.0	2.0	M Ω	RIN
input capacitance	CERDIP	2.5	3.5	3.5	3.5	pF	CIN
	Plastic DIP	1.25	2.0	2.0	2.0	pF	CIN
output voltage range	no load	4.0	3.6	3.8	3.8	V	VO
	$R_L = 100\Omega$	+3.8,-2.5	+3.0,-1.2	+3.6,-2.0	+3.6,-2.5	V	VOL
	$R_L = 100\Omega$, 0°C		+3.0,-1.6			V	VOL
output current		+60,-30	+40,-12	+40,-20	+40,-30	mA	IO
	0°C		+40,-16			mA	IO

Min/max ratings are based on product characterization and simulation. Individual parameters are tested as noted. Outgoing quality levels are determined from tested parameters.

Absolute Maximum Ratings

V_{CC}	$\pm 7.0V$
I_{out}	output is short circuit protected to ground, but maximum reliability will be maintained if I_{out} does not exceed...
input voltage	30mA
maximum junction temperature	$\pm V_{CC}$
operating temperature range	+150°C
AJ	-40°C to +85°C
A8/AM/AL	-55°C to +125°C
storage temperature range	-65°C to +150°C
lead temperature (soldering 10 sec)	+300°C
ESD rating	1000V

Miscellaneous Ratings

Notes:
* AJ : 100% tested at +25°C.

Package Thermal Resistance

Package	θ_{JC}	θ_{JA}
Plastic (AJP)	70°C/W	125°C/W
Surface Mount (AJE)	65°C/W	145°C/W
SOT	130°C/W	200°C/W

Reliability Information

Transistor count

17

Electrical Characteristics ($V_{CC}=+3V$ or $V_{CC}=+5V$, $-V_{EE}=0V$, $T_A=+25^\circ C$, $R_L=100\Omega$, unless noted)

PARAMETERS	CONDITIONS	$V_{CC}=3V$	$V_{CC}=5V$	UNITS
FREQUENCY DOMAIN RESPONSE				
-3dB bandwidth	$V_{out} < 0.5V_{pp}$	30	90	MHz
	$V_{out} < 2.0V_{pp}$		35	MHz
gain flatness	$V_{out} < 0.5V_{pp}$			
flatness	DC to 30MHz	3	0.3	dB
peaking	DC to 200MHz	0	0	dB
rolloff	DC to 60MHz		1.5	dB
TIME DOMAIN RESPONSE				
rise and fall time	0.5V step	13.9	4.7	ns
	2.0V step		13.5	ns
overshoot	0.5V step	0	0	%
slew rate	0.5V step	35	200	V/ μ s
DISTORTION AND NOISE RESPONSE				
2 nd harmonic distortion	0.5V _{pp} , 20MHz	-32		dBc
	1.0V _{pp} , 20MHz		-37	dBc
3 rd harmonic distortion	0.5V _{pp} , 20MHz	-29		dBc
	1.0V _{pp} , 20MHz		-43	dBc
STATIC DC PERFORMANCE				
small-signal gain	AC-coupled	0.89	0.94	V/V
supply current	$R_L = \infty$	0.75	1.6	mA
MISCELLANEOUS PERFORMANCE				
output voltage range	$R_L = \infty$	1.5	2.8	V_{pp}
	$R_L = 100\Omega$	1.1	2.6	V_{pp}

Operation

The CLC109 is a low-power, high-speed unity-gain buffer. It uses a closed-loop topology which allows for accuracy not usually found in high-speed buffers. A closed-loop design provides high accuracy and low output impedance through a wide bandwidth.

Single Supply Operation

Although the CLC109 is specified to operate from split $\pm 5V$ power supplies, there is no internal ground reference that prevents operation from a single voltage power supply. For single supply operation the input signal should be biased at a DC value of $\frac{1}{2}V_{CC}$. This can be accomplished by AC coupling and rebiasing as shown in the "Typical Application" illustrations on the front page.

The above electrical specifications provide typical performance specifications for the CLC109 at $25^\circ C$ while operating from a single +3V or a single +5V power supply.

Printed Circuit Layout and Supply Bypassing

As with any high-frequency device, a good PCB layout is required for optimum performance. This is especially important for a device as fast as the CLC109.

To minimize capacitive feedthrough, pins 2, 3, 6, and 7 should be connected to the ground plane, as shown in Figure 1. Input and output traces should be laid out as transmission lines with the appropriate termination resistors very near the CLC109. On a 0.065 inch epoxy PCB material, a 50Ω transmission line (commonly called stripline) can be constructed by using a trace width of 0.1" over a complete ground plane.

Figure 1 shows recommended power supply bypassing.

Parasitic or load capacitance directly on the output of the CLC109 will introduce additional phase shift in the device.

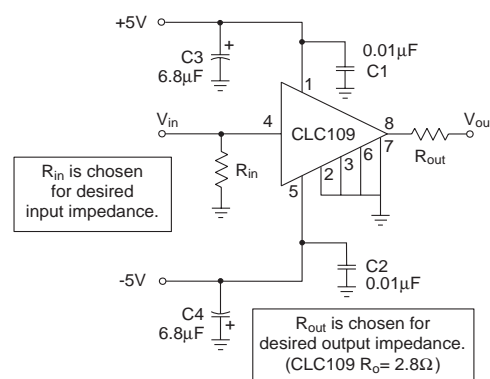

Figure 1: Recommended circuit & evaluation board schematic

This phase shift can decrease phase margin and increase frequency response peaking. A small series resistor inserted between pin 6 and the capacitance effectively decouples this effect. The graphs on the following page illustrate the required resistor value and the resulting performance vs. capacitance.

Precision buffered resistors (PRP8351 series from Precision Resistive Products), which have low parasitic reactances, were used to develop the data sheet specifications. Precision carbon composition resistors or standard spirally-trimmed RN55D metal film resistors will work, though they may cause a slight degradation of ac performance due to their reactive nature at high frequencies.

Evaluation Boards

Evaluation boards are available from National as part CLC730012 (DIP) and CLC730045 (SOIC). This board was used in the characterization of the device and provides optimal performance. Designers are encouraged to copy these printed circuit board layouts for their applications.

Typical Performance Characteristics $(T_A = +25^\circ\text{C}, V_{CC} = +5\text{V}, R_L = 100\Omega \text{ unless specified})$

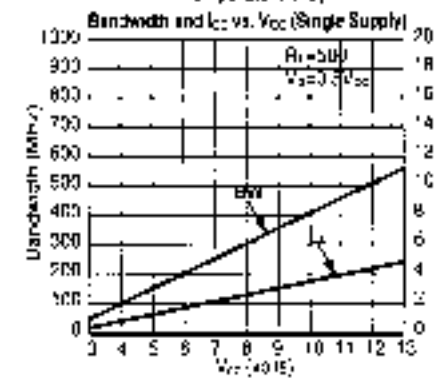
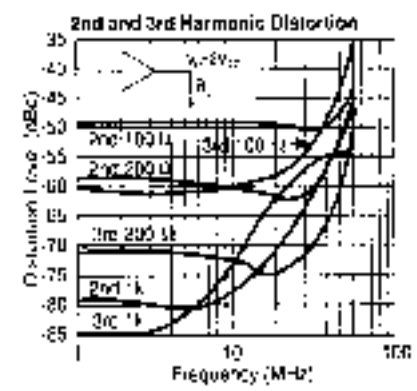
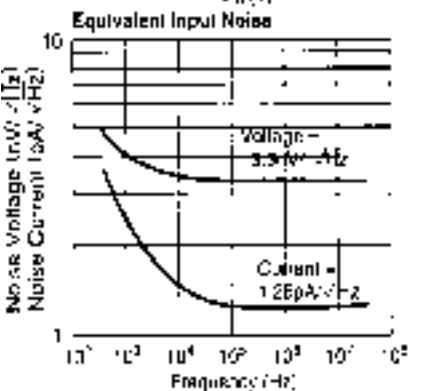
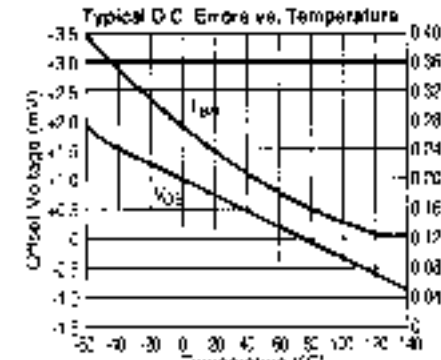
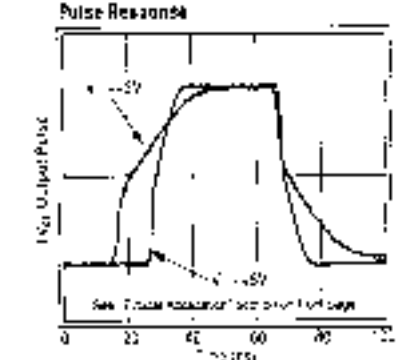
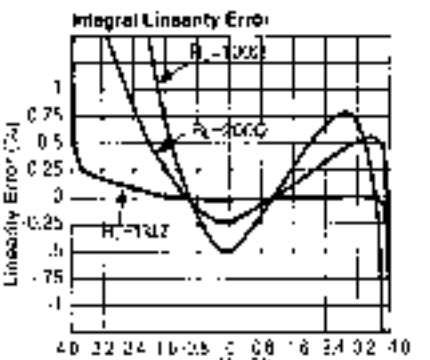
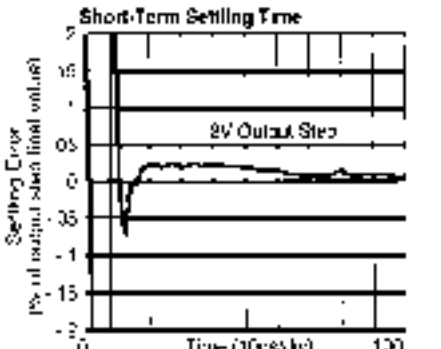
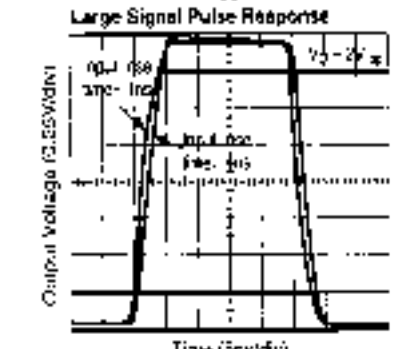
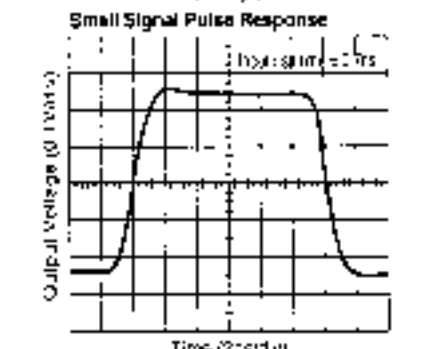
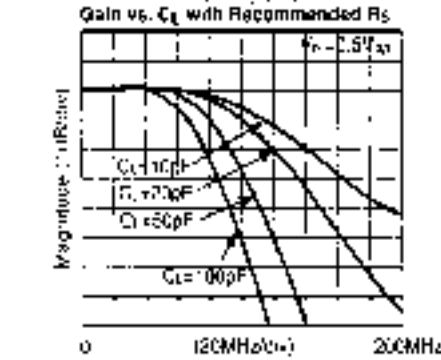
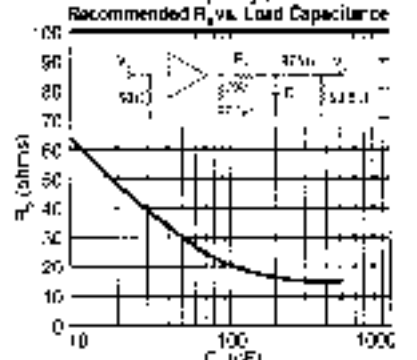
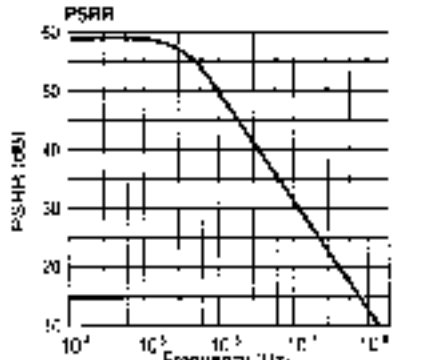
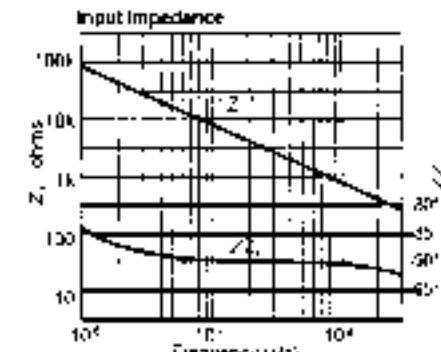
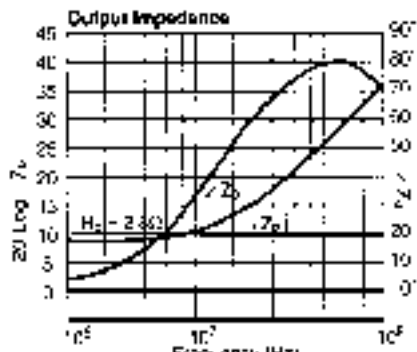
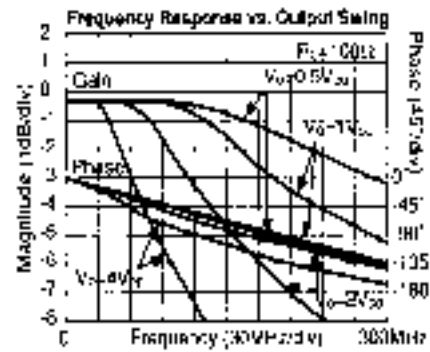

This page intentionally left blank.

Customer Design Applications Support

National Semiconductor is committed to design excellence. For sales, literature and technical support, call the National Semiconductor Customer Response Group at **1-800-272-9959** or fax **1-800-737-7018**.

Life Support Policy

National's products are not authorized for use as critical components in life support devices or systems without the express written approval of the president of National Semiconductor Corporation. As used herein:

1. Life support devices or systems are devices or systems which, a) are intended for surgical implant into the body, or b) support or sustain life, and whose failure to perform, when properly used in accordance with instructions for use provided in the labeling, can be reasonably expected to result in a significant injury to the user.
2. A critical component is any component of a life support device or system whose failure to perform can be reasonably expected to cause the failure of the life support device or system, or to affect its safety or effectiveness.



National Semiconductor Corporation

1111 West Bardin Road
Arlington, TX 76017
Tel: 1(800) 272-9959
Fax: 1(800) 737-7018

National Semiconductor Europe

Fax: (+49) 0-180-530 85 86
E-mail: europe.support.nsc.com
Deutsch Tel: (+49) 0-180-530 85 85
English Tel: (+49) 0-180-532 78 32
Francais Tel: (+49) 0-180-532 93 58
Italiano Tel: (+49) 0-180-534 16 80

National Semiconductor Hong Kong Ltd.

13th Floor, Straight Block
Ocean Centre, 5 Canton Road
Tsimshatsui, Kowloon
Hong Kong
Tel: (852) 2737-1600
Fax: (852) 2736-9960

National Semiconductor Japan Ltd.

Tel: 81-043-299-2309
Fax: 81-043-299-2408

National does not assume any responsibility for use of any circuitry described, no circuit patent licenses are implied and National reserves the right at any time without notice to change said circuitry and specifications.

IMPORTANT NOTICE

Texas Instruments Incorporated and its subsidiaries (TI) reserve the right to make corrections, modifications, enhancements, improvements, and other changes to its products and services at any time and to discontinue any product or service without notice. Customers should obtain the latest relevant information before placing orders and should verify that such information is current and complete. All products are sold subject to TI's terms and conditions of sale supplied at the time of order acknowledgment.

TI warrants performance of its hardware products to the specifications applicable at the time of sale in accordance with TI's standard warranty. Testing and other quality control techniques are used to the extent TI deems necessary to support this warranty. Except where mandated by government requirements, testing of all parameters of each product is not necessarily performed.

TI assumes no liability for applications assistance or customer product design. Customers are responsible for their products and applications using TI components. To minimize the risks associated with customer products and applications, customers should provide adequate design and operating safeguards.

TI does not warrant or represent that any license, either express or implied, is granted under any TI patent right, copyright, mask work right, or other TI intellectual property right relating to any combination, machine, or process in which TI products or services are used. Information published by TI regarding third-party products or services does not constitute a license from TI to use such products or services or a warranty or endorsement thereof. Use of such information may require a license from a third party under the patents or other intellectual property of the third party, or a license from TI under the patents or other intellectual property of TI.

Reproduction of TI information in TI data books or data sheets is permissible only if reproduction is without alteration and is accompanied by all associated warranties, conditions, limitations, and notices. Reproduction of this information with alteration is an unfair and deceptive business practice. TI is not responsible or liable for such altered documentation. Information of third parties may be subject to additional restrictions.

Resale of TI products or services with statements different from or beyond the parameters stated by TI for that product or service voids all express and any implied warranties for the associated TI product or service and is an unfair and deceptive business practice. TI is not responsible or liable for any such statements.

TI products are not authorized for use in safety-critical applications (such as life support) where a failure of the TI product would reasonably be expected to cause severe personal injury or death, unless officers of the parties have executed an agreement specifically governing such use. Buyers represent that they have all necessary expertise in the safety and regulatory ramifications of their applications, and acknowledge and agree that they are solely responsible for all legal, regulatory and safety-related requirements concerning their products and any use of TI products in such safety-critical applications, notwithstanding any applications-related information or support that may be provided by TI. Further, Buyers must fully indemnify TI and its representatives against any damages arising out of the use of TI products in such safety-critical applications.

TI products are neither designed nor intended for use in military/aerospace applications or environments unless the TI products are specifically designated by TI as military-grade or "enhanced plastic." Only products designated by TI as military-grade meet military specifications. Buyers acknowledge and agree that any such use of TI products which TI has not designated as military-grade is solely at the Buyer's risk, and that they are solely responsible for compliance with all legal and regulatory requirements in connection with such use.

TI products are neither designed nor intended for use in automotive applications or environments unless the specific TI products are designated by TI as compliant with ISO/TS 16949 requirements. Buyers acknowledge and agree that, if they use any non-designated products in automotive applications, TI will not be responsible for any failure to meet such requirements.

Following are URLs where you can obtain information on other Texas Instruments products and application solutions:

Products

Audio	www.ti.com/audio
Amplifiers	amplifier.ti.com
Data Converters	dataconverter.ti.com
DLP® Products	www.dlp.com
DSP	dsp.ti.com
Clocks and Timers	www.ti.com/clocks
Interface	interface.ti.com
Logic	logic.ti.com
Power Mgmt	power.ti.com
Microcontrollers	microcontroller.ti.com
RFID	www.ti-rfid.com
OMAP Mobile Processors	www.ti.com/omap
Wireless Connectivity	www.ti.com/wirelessconnectivity

Applications

Communications and Telecom	www.ti.com/communications
Computers and Peripherals	www.ti.com/computers
Consumer Electronics	www.ti.com/consumer-apps
Energy and Lighting	www.ti.com/energy
Industrial	www.ti.com/industrial
Medical	www.ti.com/medical
Security	www.ti.com/security
Space, Avionics and Defense	www.ti.com/space-avionics-defense
Transportation and Automotive	www.ti.com/automotive
Video and Imaging	www.ti.com/video

TI E2E Community Home Page

e2e.ti.com

Mailing Address: Texas Instruments, Post Office Box 655303, Dallas, Texas 75265
Copyright © 2011, Texas Instruments Incorporated