

CLC407

CLC407 Low Cost, Low Power, 110 MHz Programmable Gain Buffer with Disable



Literature Number: SNOS816

Comlinear CLC407

Low-Cost, Low-Power Programmable Gain Buffer with Disable

General Description

The Comlinear CLC407 is a low-cost, high-speed (110MHz) buffer which features user-programmable gains of +2, +1, and -1 V/V. This high-performance part has the added versatility of a TTL-compatible disable which quickly switches the buffer off in 18ns and back on in 40ns. The CLC407's high 60mA output current, coupled with its ultra-low 35mW power consumption makes it the ideal choice for demanding applications that are sensitive to both power and cost.

Utilizing Comlinear's proven architectures, this current feedback amplifier surpasses the performance of alternate solutions with a closed-loop design that produces new standards for buffers in gain accuracy, input impedance, and input bias currents. The CLC407's internal feedback network provides an excellent gain accuracy of 0.1%. High source impedance applications will benefit from the CLC407's 6MΩ input impedance along with its exceptionally low 100nA input bias current.

With 0.1dB flatness to 30MHz and low differential gain and phase errors, the CLC407 is very useful for professional video processing and distribution. A 110MHz -3dB bandwidth coupled with a 350V/μs slew rate also make the CLC407 a perfect choice in cost-sensitive applications such as video monitors, fax machines, copiers, and CATV systems. Back-terminated video applications will especially appreciate +2 gains which require no external gain components reducing inventory costs and board space.

Features

- Low-cost
- High output current: 60mA
- High input impedance: 6MΩ
- Gains of ±1, +2 with no external components
- Low power: I_{CC} = 3.5mA
- Ultra-fast enable/disable times
- Very low input bias currents: 100nA
- Excellent gain accuracy: 0.1%
- High speed: 110MHz -3dB BW

Applications

- Desktop video systems
- Multiplexers
- Video distribution
- Flash A/D driver
- High-speed switch/driver
- High-source impedance applications
- Peak detector circuits
- Professional video processing
- High resolution monitors

Frequency Response (A_v = +2V/V)

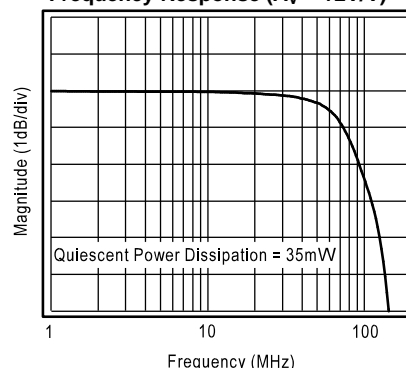

Typical Application 2:1 Mux Cable Driver

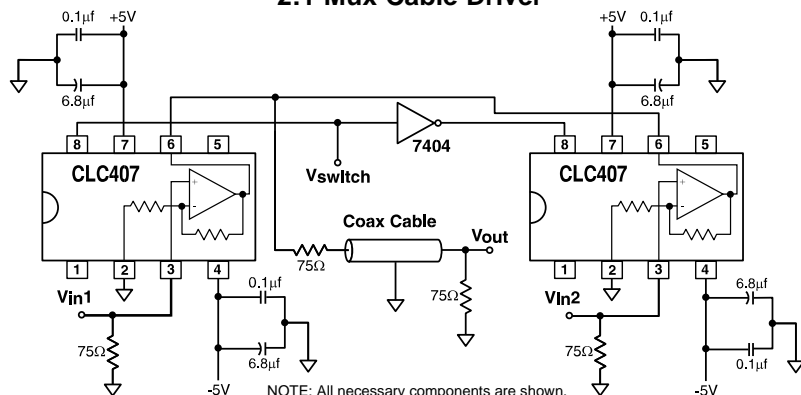

Channel Switching

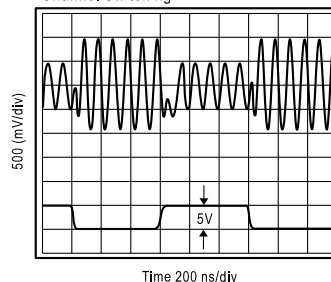

Pinout DIP & SOIC

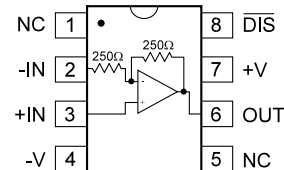

CLC407 Electrical Characteristics ($A_V = +2$, $V_{CC} = \pm 5V$, $R_L = 100\Omega$ unless specified)

PARAMETERS	CONDITIONS	TYP	MIN/MAX RATINGS			UNITS	NOTES
Ambient Temperature	CLC407AJ	+25°C	+25°C	0 to 70°C	-40 to 85°C		
FREQUENCY DOMAIN RESPONSE							
-3dB bandwidth	$V_{out} < 1.0V_{pp}$	110	75	50	45	MHz	B
	$V_{out} < 5.0V_{pp}$	42	31	27	26	MHz	1
± 0.1 dB bandwidth	$V_{out} < 1.0V_{pp}$	30	15			MHz	
gain flatness	$V_{out} < 1.0V_{pp}$						
peaking	DC to 200MHz	0	0.4	0.6	0.8	dB	B
rolloff	<30MHz	0.1	0.5	0.65	0.7	dB	B
linear phase deviation	<20MHz	0.3	0.6	0.7	0.7	deg	
differential gain	NTSC, $R_L=150\Omega$	0.03	0.05	0.06	0.07	%	
	NTSC, $R_L=150\Omega$ (Note 2)	0.01				%	2
differential phase	NTSC, $R_L=150\Omega$	0.25	0.4	0.5	0.55	deg	
	NTSC, $R_L=150\Omega$ (Note 2)	0.08				deg	2
TIME DOMAIN RESPONSE							
rise and fall time	2V step	5	7.5	8.2	8.4	ns	
settling time to 0.05%	2V step	18	27	36	39	ns	
overshoot	2V step	3	12	12	12	%	
slew rate	$A_V = +2$	350	260	225	215	V/ μ s	
	$A_V = -1$	650				V/ μ s	
DISTORTION AND NOISE RESPONSE							
2nd harmonic distortion	$2V_{pp}$, 1MHz/10MHz	-72/-52	-46	-45	-44	dBc	B, C
3rd harmonic distortion	$2V_{pp}$, 1MHz/10MHz	-70/-57	-50	-47	-46	dBc	B, C
equivalent input noise							
non-inverting voltage	>1MHz	5	6.3	6.6	6.7	nV/ \sqrt Hz	
inverting current	>1MHz	12	15	16	17	pA/ \sqrt Hz	
non-inverting current	>1MHz	3	3.8	4	4.2	pA/ \sqrt Hz	
STATIC DC PERFORMANCE							
input offset voltage		1	5	7	8	mV	
average drift		30		50	50	μ V/°C	
input bias current	non-inverting	100	900	1600	2800	nA	A
average drift		3		8	11	nA/°C	
input bias current	inverting	1	5	6	8	μ A	
average drift		17		40	45	nA/°C	
output offset voltage		2.5	13	17	19	mV	A,3
amplifier gain error		$\pm 0.1\%$	$\pm 1.0\%$	$\pm 1.0\%$	$\pm 1.0\%$	V/V	A
internal feedback resistor (R_f)		250	$\pm 20\%$			Ω	
power supply rejection ratio	DC	52	47	46	45	dB	B
common-mode rejection ratio	DC	50	45	44	43	dB	
supply current	$R_L = \infty$	3.5	4.0	4.1	4.4	mA	A
disabled	$R_L = \infty$	0.8	0.9	0.95	1	mA	A
SWITCHING PERFORMANCE							
turn on time		40	55	58	58	ns	
turn off time	to >50dB attn. @ 10MHz	18	26	30	32	ns	
off isolation	10MHz	85	80	80	80	dB	
high input voltage	V_{IH}		2	2	2	V	
low input voltage	V_{IL}		0.8	0.8	0.8	V	
MISCELLANEOUS PERFORMANCE							
input resistance	non-inverting	6	3	2.4	1	M Ω	
input capacitance	non-inverting	1	2	2	2	pF	
common mode input range		± 2.2	1.8	1.7	1.5	V	
output voltage range	$R_L = \infty$	+4.0,-3.3	+3.9,-3.2	+3.8,-3.1	+3.7,-2.8	V	
output current		60	44	38	20	mA	
output resistance, closed loop		0.06	0.2	0.25	0.4	Ω	

Recommended gain range ± 1 , +2 V/V

Min/max ratings are based on product characterization and simulation. Individual parameters are tested as noted. Outgoing quality levels are determined from tested parameters.

Absolute Maximum Ratings

supply voltage	$\pm 7V$
I_{out} is short circuit protected to ground	
common-mode input voltage	$\pm V_{CC}$
maximum junction temperature	+175°C
storage temperature range	-65°C to +150°C
lead temperature (soldering 10 sec)	+300°C

Notes

- At temps < 0°C, spec is guaranteed for $R_L = 500\Omega$.
 - An 825 Ω pull-down resistor is connected between V_o and $-V_{CC}$.
 - Source impedance 1k Ω .
- A) J-level: spec is 100% tested at +25°C, sample tested at +85°C.
 LC/MC-level: spec is 100% wafer probed at +25°C.
 B) J-level: spec is sample tested at +25°C.
 C) Guaranteed at 10MHz.

CLC407 Typical Performance Characteristics ($A_V = +2$, $R_f = 250\Omega$; $V_{CC} = \pm 5V$, $R_L = 100\Omega$ unless specified)

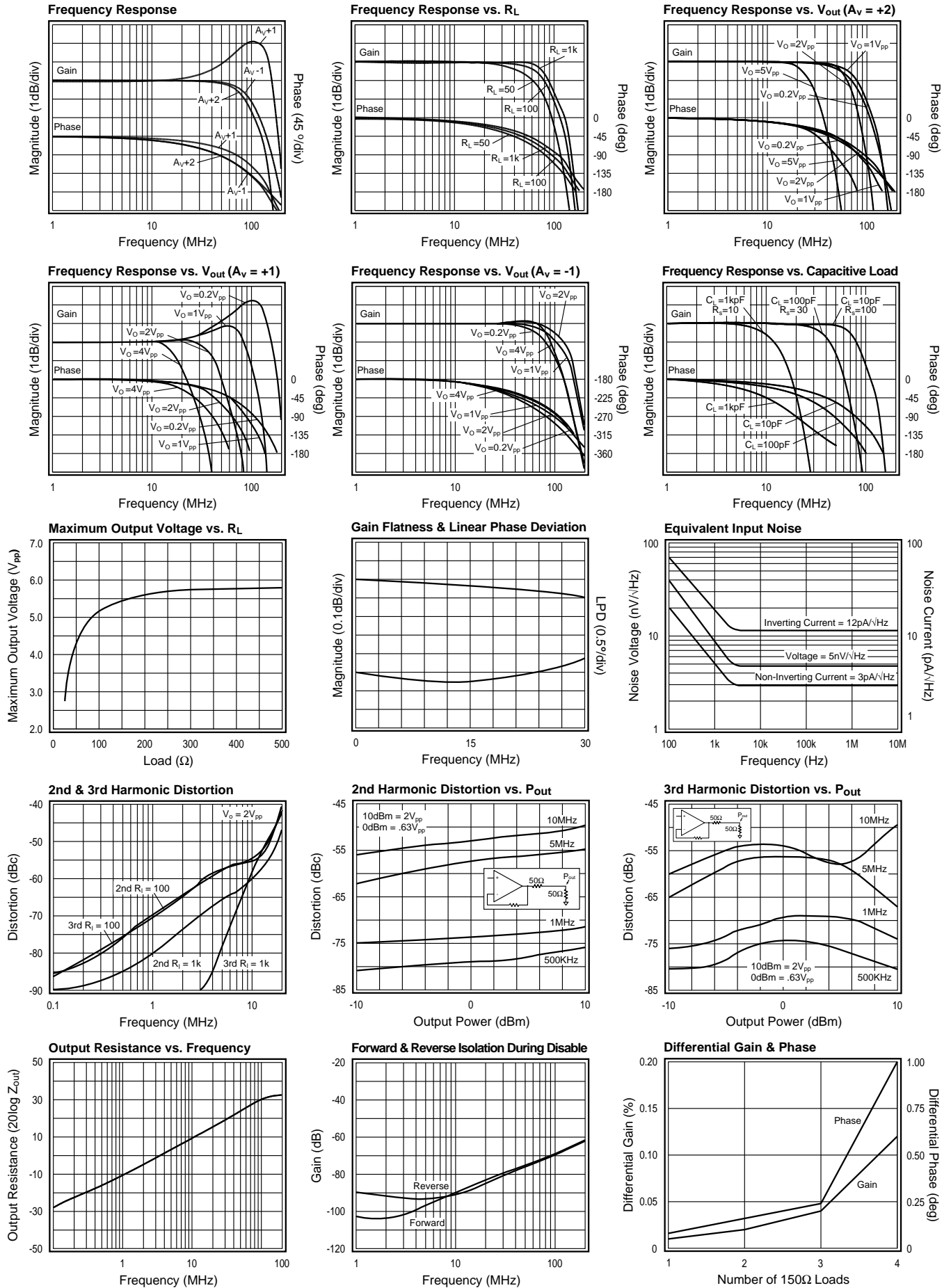

CLC407 Typical Performance Characteristics ($A_V = +2$, $R_f = 250\Omega$; $V_{CC} = \pm 5V$, $R_L = 100\Omega$ unless specified)

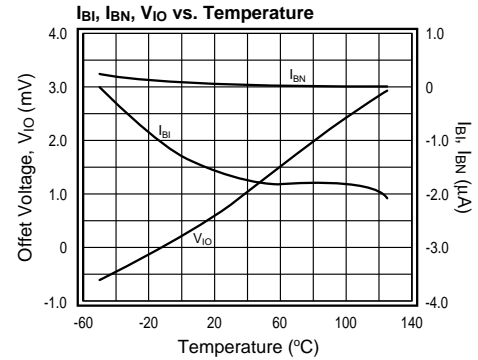
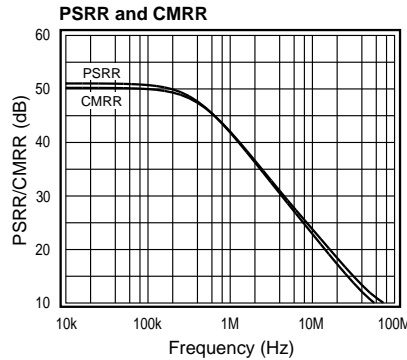
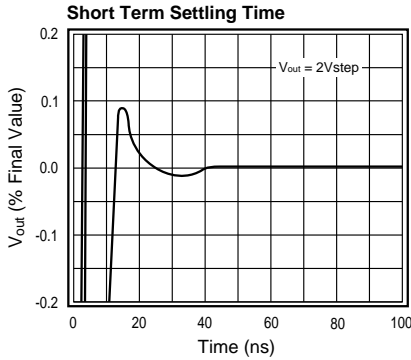
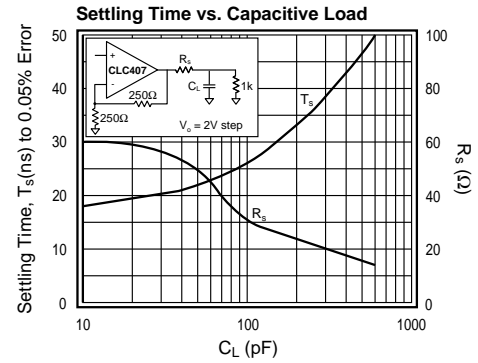
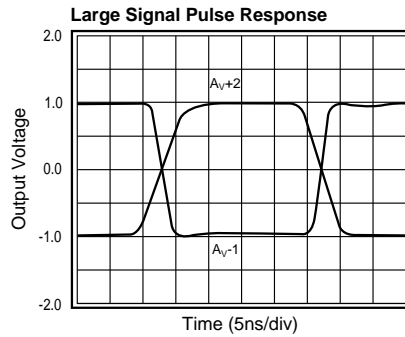
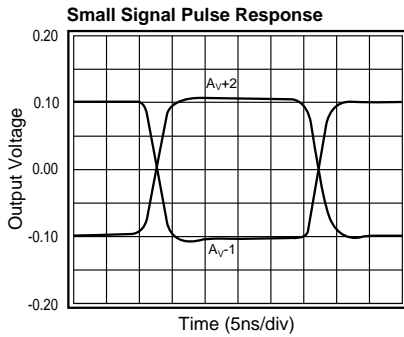

CLC407 OPERATION

Closed Loop Gain Selection

The CLC407 is a current feedback op amp with $R_f = R_g = 250\Omega$ on chip (in the package). Select from three closed loop gains without using any external gain or feedback resistors. Implement gains of +2, +1, and -1V/V by connecting pins 2 and 3 as described in the chart below.

Gain A_{cl}	Input Connections	
	Non-Inverting (pin3)	Inverting (pin2)
-1V/V	ground	input signal
+1V/V	input signal	NC (open)
+2V/V	input signal	ground

Minimize this capacitive coupling during layout by removing ground plane near pins 1, 2, and 3. This minimization should produce a response similar to the plot labeled "open" in Graph 1. If desired flatness is greater than plot "open" in Graph 1, two options remain to further flatten the frequency response. First, try shorting the inverting input (pin 2) to the non-inverting input (pin 3). This response is labeled "short" in Graph 1. Next, try inserting a 300Ω resistor R between the non-inverting input (pin 2) as shown in Figure 1. This response is labeled " 300Ω " in Graph 1. Notice an "open" produces a response with obvious peaking and maximum bandwidth, a "short" minimizes peaking and bandwidth, and finally 300Ω slightly extends bandwidth with minimal peaking.

The gain accuracy of the CLC407 is excellent and stable over temperature change. The internal gain setting resistors, R_f and R_g are diffused silicon resistors with a process variation of $\pm 20\%$ and a temperature coefficient of $\sim 2000\text{ppm}/^{\circ}C$. Although their absolute values change with processing and temperature, their ratio (R_f/R_g) remains constant. If an external resistor is used in series with R_g , gain accuracy over temperature will suffer.

Non-Inverting Unity Gain Considerations ($A_V = +1V/V$)

Achieve a gain of +1V/V by removing all resistive and capacitive connections between pin 2 and ground plane. Any capacitive coupling between pin 2 and ground will cause high frequency peaking in the frequency domain response and overshoot in the time domain response.

Frequency Response vs. Unity Gain Configuration

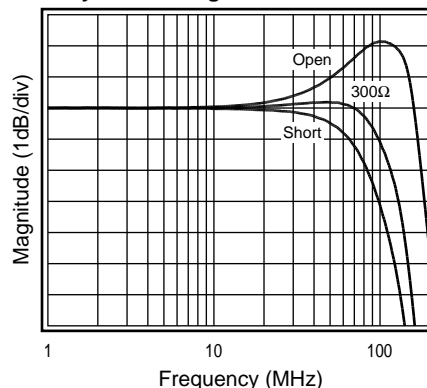

Graph 1

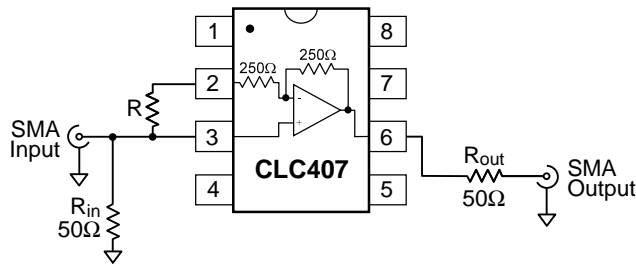

Figure 1

Enable/Disable Operation Using ±5V Supplies

The CLC407 has a TTL & CMOS logic compatible disable function. Apply a logic low (i.e. < 0.8V) to pin 8, and the CLC407 is guaranteed disabled across its temperature range. Apply a logic high to pin 8, (i.e. > 2.0V) and the CLC407 is guaranteed enabled. Voltage, not current, at pin 8 determines the enable/disable state of the CLC407.

Disable the CLC407 and its inputs and output become high impedances. While disabled, the CLC407's quiescent power drops to 8mW.

Use the CLC407's disable to create analog switches or multiplexers. Implement a single analog switch with one CLC407 positioned between an input and output. Create an analog multiplexer with several CLC407s. Tie the outputs together and put a different signal on each CLC407 input.

Operate the CLC407 without connecting pin 8. An internal 20kΩ pull-up resistor guarantees the CLC407 is enabled when pin 8 is floating.

Enable/Disable Operation for Single or Unbalanced Supply Operation

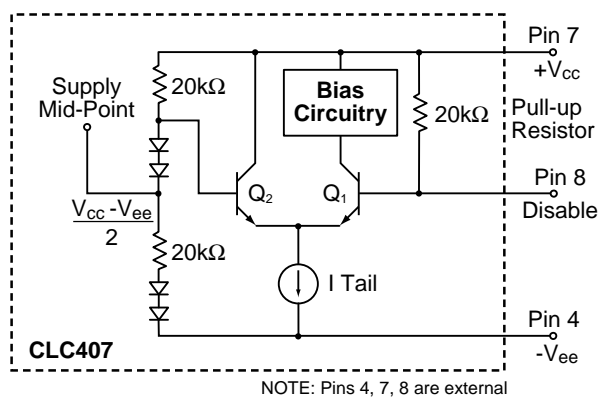

Figure 2

Figure 2 illustrates the internal enable/disable operation of the CLC407. When pin 8 is left floating or is tied to +V_{cc}, Q₁ is on and pulls tail current through the CLC407 circuitry. When pin 8 is less than 0.8V above the supply mid-point, Q₁ stops tail current from flowing in the bias circuitry. The CLC407 is now disabled.

Disable Limitations

The internal feedback resistor, R_f limits off isolation in inverting gain configurations. Do not apply voltages greater than +V_{cc} or less than -V_{ee} to pin 8.

Input - Bias Current, Impedances, and Source Termination Considerations

The CLC407 has:

- a 6MΩ non-inverting input impedance.
- 100nA non-inverting input bias current.

If a large source impedance application is considered, remove all parasitic capacitance around the non-inverting input and source traces. Parasitic capacitances near the input and source act as a low-pass filter and reduce bandwidth.

Current feedback op amps have uncorrelated input bias currents. These uncorrelated bias currents prevent source impedance matching on each input from cancelling offsets. Refer to application note OA-07 of the data book to find specific circuits to correct DC offsets.

Layout Considerations

Whenever questions about layout arise, USE THE EVALUATION BOARD AS A TEMPLATE.

Use the 730013 and 730026 evaluation boards for the DIP and SOIC respectively. These board layouts were optimized to produce the typical performance of the CLC407 shown in the data sheet. To reduce parasitic capacitances, the ground plane was removed near pins 2, 3, and 6. To reduce series inductance, trace lengths of components and nodes were minimized.

Parasitics on traces degrade performance. Minimize coupling from traces to both power and ground planes. Use low inductance resistors for leaded components.

Do not use dip sockets for the CLC407 DIP amplifiers. These sockets can peak the frequency domain response or create overshoot in the time domain response. Use flush-mount socket pins if socketing cannot be avoided. The 730013 circuit board device holes are sized for Cambion P/N 450-2598 socket pins or their functional equivalent.

Insert the back matching resistor R_{out} shown in Figure 3 when driving coaxial cable or a capacitive load. Use the plot in the typical performance section labeled "Settling Time vs. Capacitive Load" to determine the optimum resistor value for R_{out} for different capacitive loads. This optimal resistance improves settling time for pulse-type applications and increases stability.

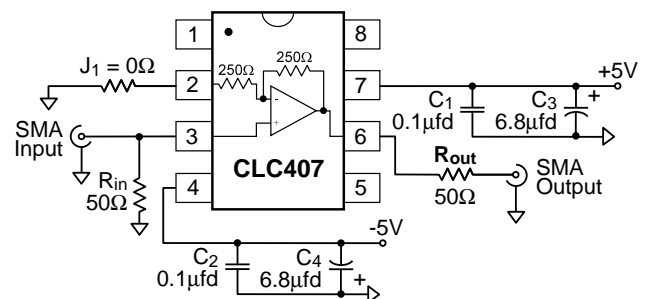

Figure 3

Use power-supply bypassing capacitors when operating this amplifier. Choose quality 0.1µF ceramics for C₁ and C₂. Choose quality 6.8µF tantalum capacitors for C₃ and C₄. Place the 0.1µF capacitors within 0.1 inches from the power pins. Place the 6.8µF capacitors within 3/4 inches from the power pins.

Special Evaluation Board Considerations for the CLC407

To optimize off-isolation of the CLC407, cut the R_f trace on both the 730013 and the 730027 evaluation boards. This cut minimizes capacitive feedthrough between the input and the output. Figure 4 shows where to cut both evaluation boards for improved off-isolation.

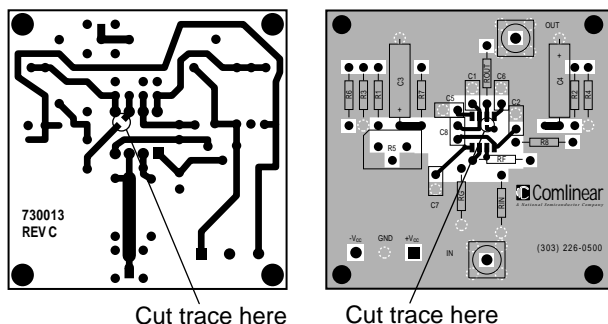
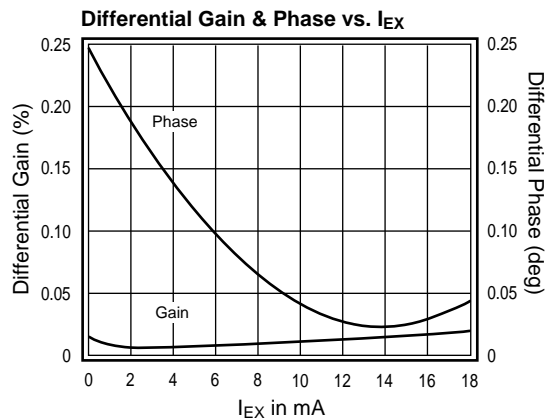

Figure 4

Video Performance vs. I_{EX}

Improve the video performance of the CLC407 by drawing extra current from the amplifier's output stage. Using a single external resistor as shown in Figure 5, you can adjust the differential phase. Video performance vs. I_{EX} is illustrated below in Graph 2. This graph represents positive video performance with negative synchronization pulses.



Graph 2

The value for R_{pd} in Figure 5 is determined by:

$$R_{pd} = \frac{5}{I_{EX}}$$

at ±5V supplies.

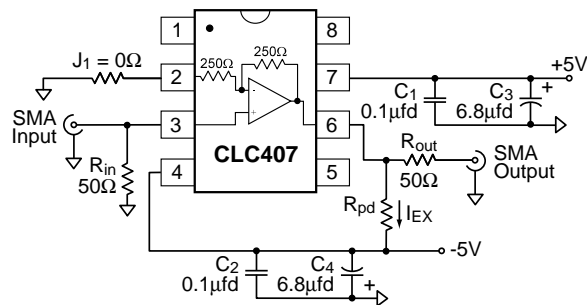

Figure 5

Video Cable Driver

The CLC407 was designed to produce exceptional video performance at all three closed-loop gains. At the non-inverting gain of 2V/V configuration, back terminate the cable using R_{out}. A typical cable driving configuration is shown below in Figure 6.

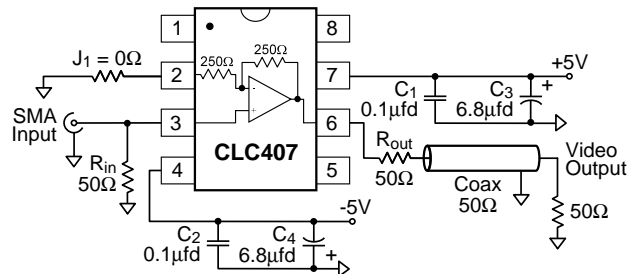

Figure 6

N:1 Mux Cable Driver

The CLC407 is capable of multiplexing several signals on a single analog output bus. The front page shows how a 2:1 multiplexer is implemented. An N:1 multiplexer is implemented in an analogous fashion by using an N:1 decoder to enable/disable the appropriate number of CLC407's.

Package Thermal Resistance

Package	θ _{jc}	θ _{JA}
Plastic (AJP)	75°/W	125°/W
Surface Mount (AJE)	130°/W	150°/W
CerDip	65°/W	155°/W

Ordering Information

Model	Temperature Range	Description
CLC407AJP	-40°C to +85°C	8-pin PDIP
CLC407AJE	-40°C to +85°C	8-pin SOIC
CLC407AIB	-40°C to +85°C	8-pin CerDIP
CLC407ALC	-40°C to +85°C	dice
CLC407A8B	-55°C to +125°C	8-pin CerDIP, MIL-STD-883
CLC407AMC	-55°C to +125°C	dice, MIL-STD-883

Contact factory for other packages and DESC SMD number.

This page intentionally left blank.

Customer Design Applications Support

National Semiconductor is committed to design excellence. For sales, literature and technical support, call the National Semiconductor Customer Response Group at **1-800-272-9959** or fax **1-800-737-7018**.

Life Support Policy

National's products are not authorized for use as critical components in life support devices or systems without the express written approval of the president of National Semiconductor Corporation. As used herein:

1. Life support devices or systems are devices or systems which, a) are intended for surgical implant into the body, or b) support or sustain life, and whose failure to perform, when properly used in accordance with instructions for use provided in the labeling, can be reasonably expected to result in a significant injury to the user.
2. A critical component is any component of a life support device or system whose failure to perform can be reasonably expected to cause the failure of the life support device or system, or to affect its safety or effectiveness.



National Semiconductor Corporation

1111 West Bardin Road
Arlington, TX 76017
Tel: 1(800) 272-9959
Fax: 1(800) 737-7018

National Semiconductor Europe

Fax: (+49) 0-180-530 85 86
E-mail: europe.support.nsc.com
Deutsch Tel: (+49) 0-180-530 85 85
English Tel: (+49) 0-180-532 78 32
Francais Tel: (+49) 0-180-532 93 58
Italiano Tel: (+49) 0-180-534 16 80

National Semiconductor Hong Kong Ltd.

13th Floor, Straight Block
Ocean Centre, 5 Canton Road
Tsimshatsui, Kowloon
Hong Kong
Tel: (852) 2737-1600
Fax: (852) 2736-9960

National Semiconductor Japan Ltd.

Tel: 81-043-299-2309
Fax: 81-043-299-2408

National does not assume any responsibility for use of any circuitry described, no circuit patent licenses are implied and National reserves the right at any time without notice to change said circuitry and specifications.

IMPORTANT NOTICE

Texas Instruments Incorporated and its subsidiaries (TI) reserve the right to make corrections, modifications, enhancements, improvements, and other changes to its products and services at any time and to discontinue any product or service without notice. Customers should obtain the latest relevant information before placing orders and should verify that such information is current and complete. All products are sold subject to TI's terms and conditions of sale supplied at the time of order acknowledgment.

TI warrants performance of its hardware products to the specifications applicable at the time of sale in accordance with TI's standard warranty. Testing and other quality control techniques are used to the extent TI deems necessary to support this warranty. Except where mandated by government requirements, testing of all parameters of each product is not necessarily performed.

TI assumes no liability for applications assistance or customer product design. Customers are responsible for their products and applications using TI components. To minimize the risks associated with customer products and applications, customers should provide adequate design and operating safeguards.

TI does not warrant or represent that any license, either express or implied, is granted under any TI patent right, copyright, mask work right, or other TI intellectual property right relating to any combination, machine, or process in which TI products or services are used. Information published by TI regarding third-party products or services does not constitute a license from TI to use such products or services or a warranty or endorsement thereof. Use of such information may require a license from a third party under the patents or other intellectual property of the third party, or a license from TI under the patents or other intellectual property of TI.

Reproduction of TI information in TI data books or data sheets is permissible only if reproduction is without alteration and is accompanied by all associated warranties, conditions, limitations, and notices. Reproduction of this information with alteration is an unfair and deceptive business practice. TI is not responsible or liable for such altered documentation. Information of third parties may be subject to additional restrictions.

Resale of TI products or services with statements different from or beyond the parameters stated by TI for that product or service voids all express and any implied warranties for the associated TI product or service and is an unfair and deceptive business practice. TI is not responsible or liable for any such statements.

TI products are not authorized for use in safety-critical applications (such as life support) where a failure of the TI product would reasonably be expected to cause severe personal injury or death, unless officers of the parties have executed an agreement specifically governing such use. Buyers represent that they have all necessary expertise in the safety and regulatory ramifications of their applications, and acknowledge and agree that they are solely responsible for all legal, regulatory and safety-related requirements concerning their products and any use of TI products in such safety-critical applications, notwithstanding any applications-related information or support that may be provided by TI. Further, Buyers must fully indemnify TI and its representatives against any damages arising out of the use of TI products in such safety-critical applications.

TI products are neither designed nor intended for use in military/aerospace applications or environments unless the TI products are specifically designated by TI as military-grade or "enhanced plastic." Only products designated by TI as military-grade meet military specifications. Buyers acknowledge and agree that any such use of TI products which TI has not designated as military-grade is solely at the Buyer's risk, and that they are solely responsible for compliance with all legal and regulatory requirements in connection with such use.

TI products are neither designed nor intended for use in automotive applications or environments unless the specific TI products are designated by TI as compliant with ISO/TS 16949 requirements. Buyers acknowledge and agree that, if they use any non-designated products in automotive applications, TI will not be responsible for any failure to meet such requirements.

Following are URLs where you can obtain information on other Texas Instruments products and application solutions:

Products

Audio	www.ti.com/audio
Amplifiers	amplifier.ti.com
Data Converters	dataconverter.ti.com
DLP® Products	www.dlp.com
DSP	dsp.ti.com
Clocks and Timers	www.ti.com/clocks
Interface	interface.ti.com
Logic	logic.ti.com
Power Mgmt	power.ti.com
Microcontrollers	microcontroller.ti.com
RFID	www.ti-rfid.com
OMAP Mobile Processors	www.ti.com/omap
Wireless Connectivity	www.ti.com/wirelessconnectivity

Applications

Communications and Telecom	www.ti.com/communications
Computers and Peripherals	www.ti.com/computers
Consumer Electronics	www.ti.com/consumer-apps
Energy and Lighting	www.ti.com/energy
Industrial	www.ti.com/industrial
Medical	www.ti.com/medical
Security	www.ti.com/security
Space, Avionics and Defense	www.ti.com/space-avionics-defense
Transportation and Automotive	www.ti.com/automotive
Video and Imaging	www.ti.com/video

TI E2E Community Home Page

e2e.ti.com

Mailing Address: Texas Instruments, Post Office Box 655303, Dallas, Texas 75265
Copyright © 2011, Texas Instruments Incorporated