

CLC400 Fast Settling, Wideband Low Gain Monolithic Op Amp

Check for Samples: [CLC400](#)

FEATURES

- -3dB bandwidth of 200MHz
- 0.05% settling in 12ns
- Low power, 150mW
- Low distortion, -60dBc at 20MHz
- Stable without compensation
- Overload and short circuit protected
- ± 1 to ± 8 closed loop gain range

APPLICATIONS

- Flash, precision A/D conversion
- Video distribution
- Line drivers
- D/A current-to-voltage conversion
- Photodiode, CCD preamps
- IF processors
- High speed communications

Pulse Response

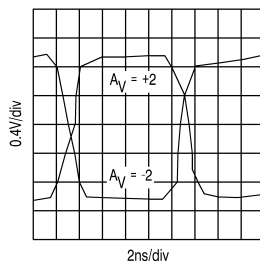

Connection Diagram

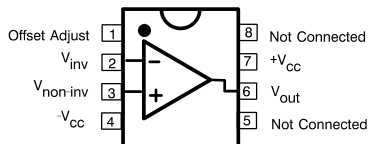

See Package Numbers D0008A and P0008E

DESCRIPTION

The CLC400 is a high speed, fast setting operational amplifier designed for low gain applications. Constructed using a unique, proprietary design and an advanced complementary bipolar process, the CLC400 offers performance far beyond that normally offered by ordinary monolithic op amps. In addition, unlike many other high speed op amps the CLC400 offers both high performance and stability without the need for compensation circuitry - even at a gain of +1.

The fast 12ns settling to 0.05% and its ability to drive capacitive loads makes the CLC400 an ideal flash A/D driver. The wide bandwidth of 200MHz and the very linear phase ensure unsurpassed signal fidelity. Systems employing digital to analog converters also benefit from the use of the CLC400 - especially if linearity and drive levels are important to system performance.

The CLC400 provides a simple, high performance solution for video distribution and line driving applications. The 50mA output current and guaranteed specifications for 100Ω loads provide ample drive capability and assured performance.

The CLC400 is based on proprietary op amp topology that uses current feedback instead of the usual voltage feedback. This unique design has many advantages over conventional designs (such as settling time that is relatively independent of gain), yet it is used in basically the same way (see the gain equations in [Figure 17](#) and [Figure 18](#)). However, an understanding of the topology will aid in achieving the best performance. The following discussion will proceed for the non-inverting gain configuration with the inverting mode analysis being very similar.

Enhanced Solutions (Military/Aerospace)

SMD Number: 5962-89970

Space level versions also available.

For more information, visit <http://www.ti.com>



These devices have limited built-in ESD protection. The leads should be shorted together or the device placed in conductive foam during storage or handling to prevent electrostatic damage to the MOS gates.



Please be aware that an important notice concerning availability, standard warranty, and use in critical applications of Texas Instruments semiconductor products and disclaimers thereto appears at the end of this data sheet.

All trademarks are the property of their respective owners.

ABSOLUTE MAXIMUM RATINGS ⁽¹⁾

Supply Voltage (V_{CC})	$\pm 7V$
I_{OUT} Output is short circuit protected to ground, but maximum reliability will be maintained if I_{OUT} does not exceed...	60mA
Common Mode Input Voltage	$\pm V_{CC}$
Differential Input Voltage	10V
Junction Temperature	+150°C
Operating Temperature Range	-40°C to +85°C
Storage Temperature Range	-65°C to +150°C
Lead Solder Duration (+300°C)	10 sec
ESD rating (human body model)	500V

(1) "Absolute Maximum Ratings" are those values beyond which the safety of the device are not ensured. They are not meant to imply that the devices should be operated at these limits. The table of "Electrical Characteristics" specifies conditions of device operation.

OPERATING RATINGS

Thermal Resistance		
Package	(θ_{JC})	(θ_{JA})
MDIP	70°C/W	125°C/W
SOIC	65°C/W	145°C/W

ELECTRICAL CHARACTERISTICS

$A_V = +2$, $V_{CC} = \pm 5V$, $R_L = 100\Omega$, $R_f = 250\Omega$; Unless Specified

Symbol	Parameter	Conditions	Typ	Max/Min Ratings ⁽¹⁾				Units
Ambient Temperature		CLC400AJ	+25°C	-40°C	+25°C	+85°C		
Frequency Domain Response								
SSBW	-3dB Bandwidth	$V_{OUT} < 0.5V_{PP}$	200	150	150	120	MHz	
LSBW		$V_{OUT} < 5V_{PP}$, $A_V = +5$	50	35	35	35	MHz	
	Gain Flatness	$V_{OUT} < 0.5V_{PP}$						
GFPL	Peaking	<40MHz	0	0.4	0.3	0.4	dB	
GFPH	Peaking	>40MHz	0	0.7	0.5	0.7	dB	
GFR	Rolloff	<75MHz	0.6	1.0	1.0	1.3	dB	
LPD	Linear Phase Deviation	to 75MHz	0.2	1.0	1.0	1.2	deg	
Time Domain Response								
TRS	Rise and Fall Time	0.5V Step	1.6	2.4	2.4	2.4	ns	
TRL		5V Step	6.5	10	10	10	ns	
TSP	Settling Time to $\pm 0.1\%$	2V Step	10	13	13	13	ns	
TS	Settling Time to $\pm 0.05\%$	2V Step	12	15	15	15	ns	
OS	Overshoot	0.5V Step	0	15	10	10	%	
SR	Slew Rate	$A_V = +2$	700	430	430	430	V/ μ s	
SR1		$A_V = -2$	1600	–	–	–	V/ μ s	
Distortion And Noise Response								
HD2	2nd Harmonic Distortion	$2V_{PP}, 20MHz$	-60	-40	-45	-45	dBc	
HD3	3rd Harmonic Distortion	$2V_{PP}, 20MHz$	-60	-50	-50	-50	dBc	
	Equivalent Input Noise							
SNF	Noise Floor	>1MHz	-157	-154	-154	-153	dBm (1Hz)	
INV	Integrated Noise	1MHz to 200MHz	40	57	57	63	μ V	
Static, DC Performance								
VIO	Input Offset Voltage ⁽²⁾		2	± 8.2	± 5.0	± 9.0	mV	
DVIO	Average Temperature Coefficient		20	± 40	–	± 40	μ V/ $^{\circ}$ C	
IBN	Input Bias Current ⁽²⁾	Non-Inverting	10	± 36	± 20	± 20	μ A	
DIBN	Average Temperature Coefficient		100	± 200	–	± 100	nA/ $^{\circ}$ C	
IBI	Input Bias Current ⁽²⁾	Inverting	10	± 36	± 20	± 30	μ A	
DIBI	Average Temperature Coefficient		50	± 200	–	± 100	nA/ $^{\circ}$ C	
PSRR	Power Supply Rejection Ratio		50	45	45	45	dB	
CMRR	Common Mode Rejection Ratio		50	45	45	45	dB	
ICC	Supply Current ⁽²⁾	No Load	15	23	23	23	mA	
Miscellaneous Performance								
RIN	Non Inverting Input	Resistance	200	>50	>100	>100	k Ω	
CIN		Capacitance	0.5	<2.0	<2.0	<2.0	pF	
RO	Output Impedance	At DC	0.1	<0.2	<0.2	<0.2	Ω	
VO	Output Voltage Range	No Load	± 3.5	>3.0	>3.2	>3.2	V	
CMIR	Common Mode Input Range	For Rated Performance	± 2.1	>1.2	>2.0	>2.0	V	
IO	Output Current		± 60	>35	>50	>50	mA	

(1) Max/min ratings are based on product characterization and simulation. Individual parameters are tested as noted. Outgoing quality levels are determined from tested parameters.

(2) AJ-level: spec. is 100% tested at +25°C, sample at 85°C.

TYPICAL PERFORMANCE CHARACTERISTICS

($T_A = 25^\circ\text{C}$, $A_V = +2$, $V_{CC} = \pm 5\text{V}$, $R_L = 100\Omega$; Unless Specified).

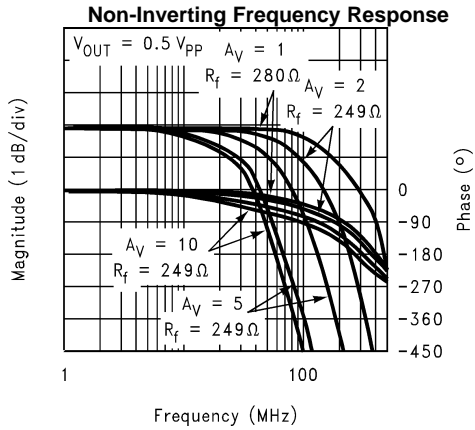

Figure 1.

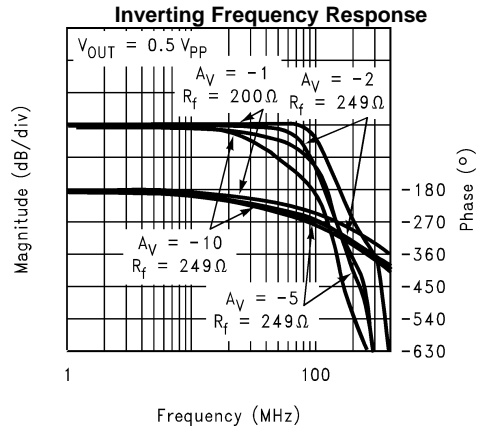

Figure 2.

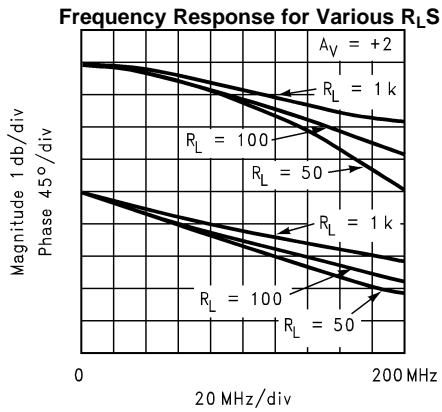

Figure 3.

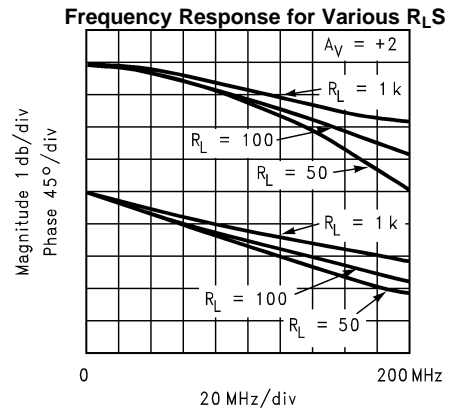

Figure 4.

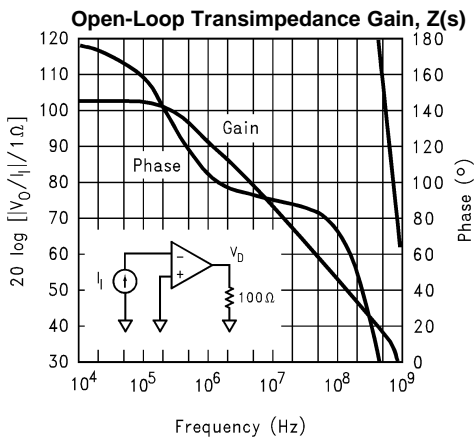

Figure 5.

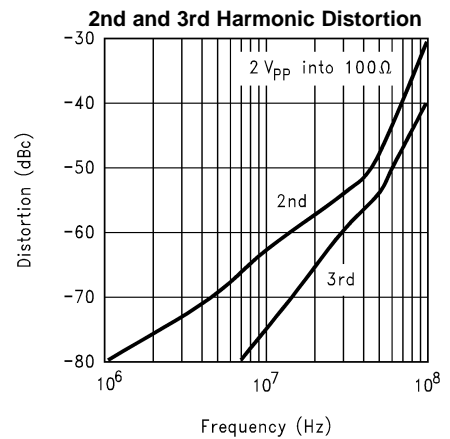

Figure 6.

TYPICAL PERFORMANCE CHARACTERISTICS (continued)

($T_A = 25^\circ\text{C}$, $A_V = +2$, $V_{CC} = \pm 5\text{V}$, $R_L = 100\Omega$; Unless Specified).

2-Tone, 3rd Order, Intermodulation Intercept

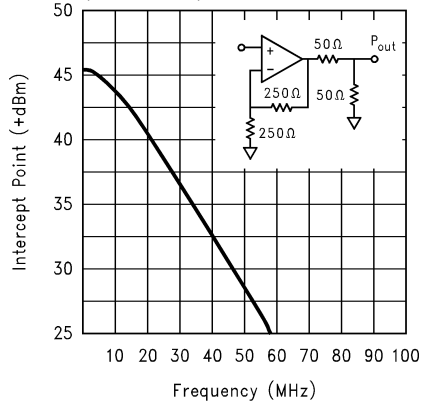

Figure 7.

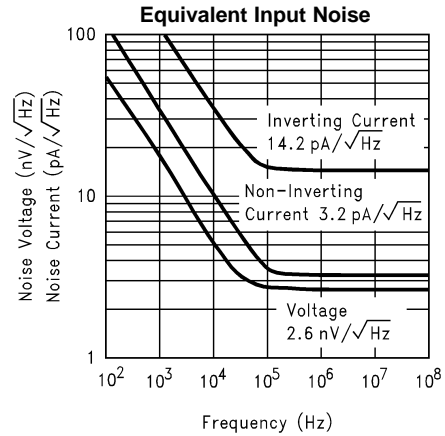

Figure 8.

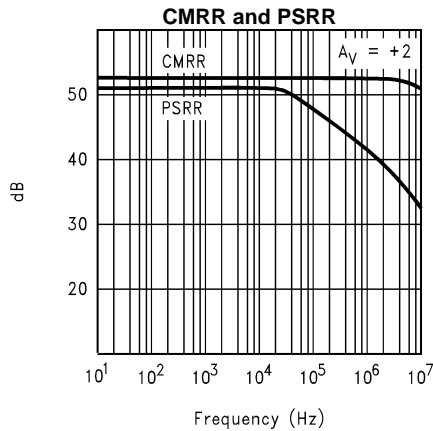

Figure 9.

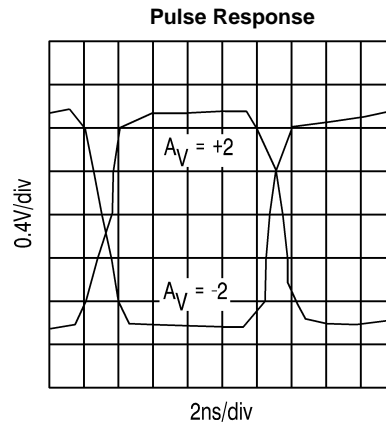

Figure 10.

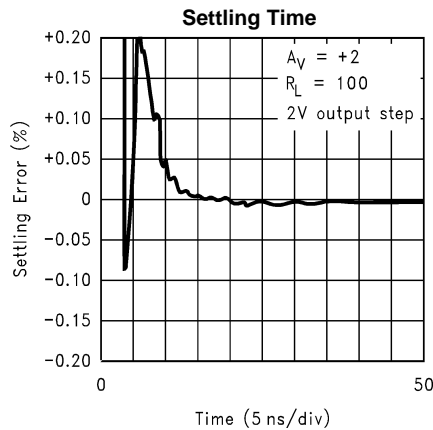

Figure 11.

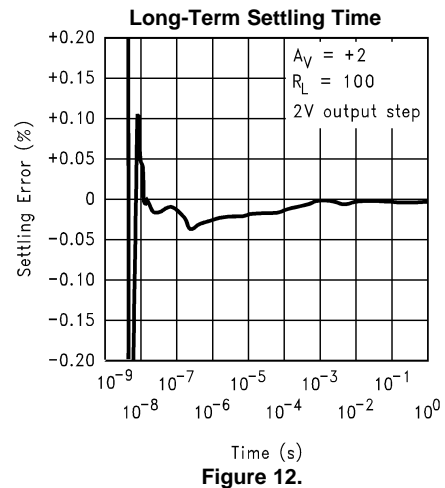

Figure 12.

TYPICAL PERFORMANCE CHARACTERISTICS (continued)

($T_A = 25^\circ\text{C}$, $A_V = +2$, $V_{CC} = \pm 5\text{V}$, $R_L = 100\Omega$; Unless Specified).

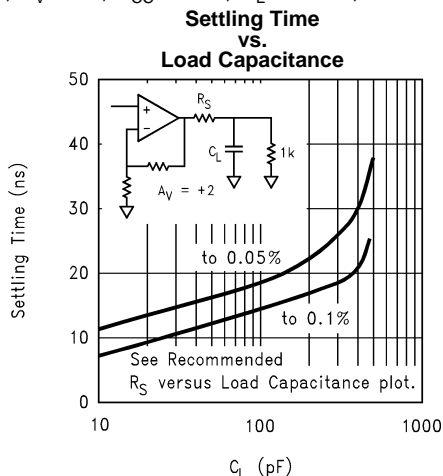

Figure 13.

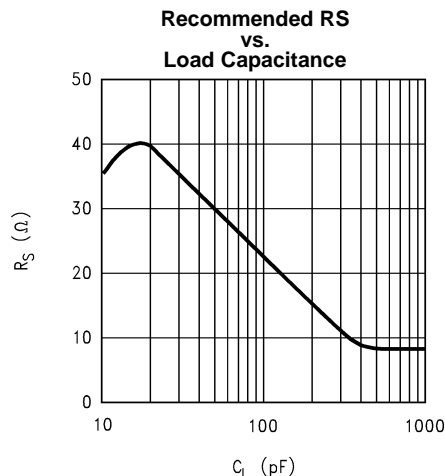

Figure 14.

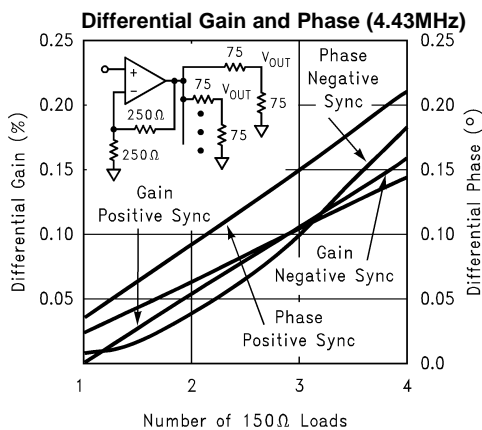

Figure 15.

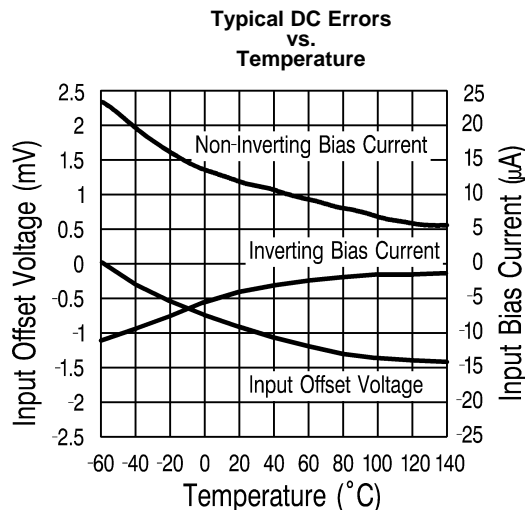

Figure 16.

APPLICATION INFORMATION

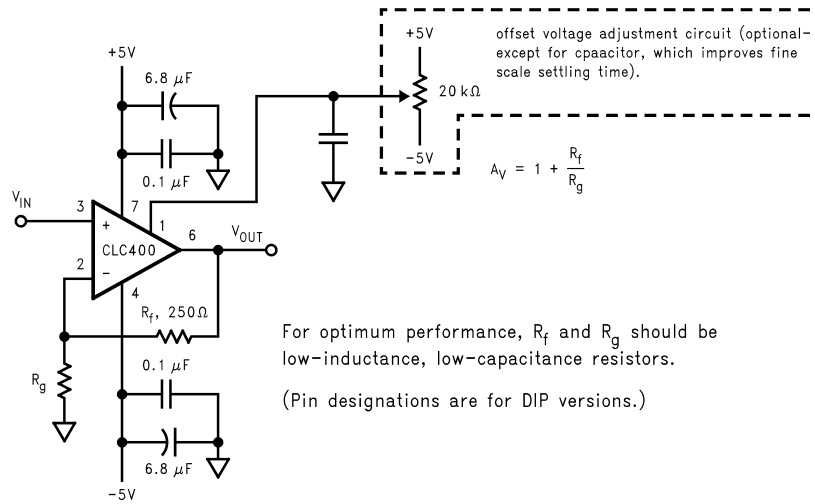

Figure 17. Recommended Non-Inverting Gain Circuit

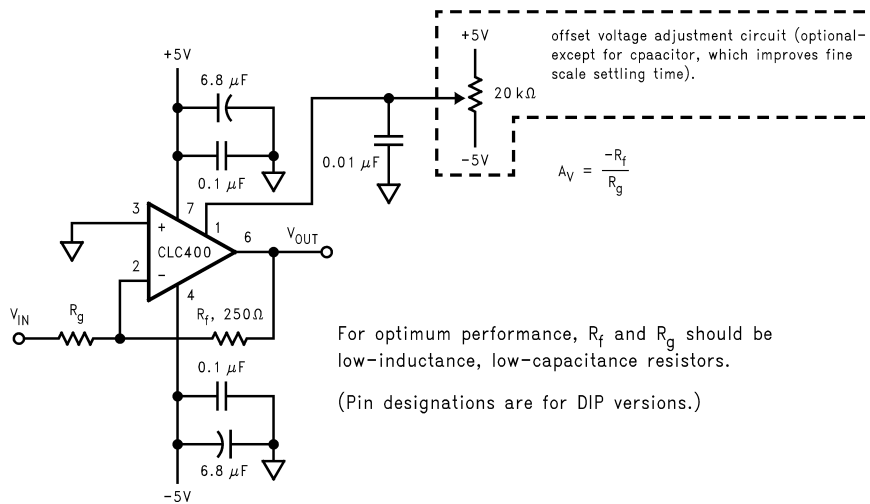

Figure 18. Recommended Inverting Gain Circuit

Understanding the Loop Gain

Referring to the equivalent circuit of Figure 19, any current flowing in the inverting input is amplified to a voltage at the output through the transimpedance gain shown on the plots. This $Z(s)$ is analogous to the open-loop gain of a voltage feedback amplifier.

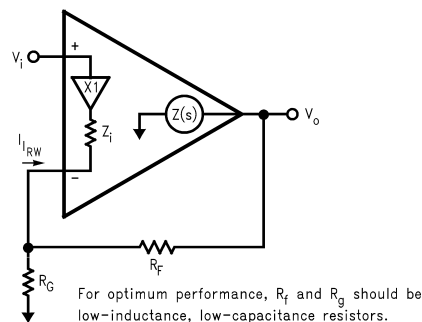

Figure 19. Current Feedback Topology

Developing the non-inverting frequency response for the topology of [Figure 19](#) yields:

$$\frac{V_o}{V_i} = \frac{1 + R_f / R_g}{1 - 1 / LG} \quad (1)$$

where LG is the loop gain defined by,

$$LG = \frac{Z(s)}{R_f} \times \frac{1}{1 + Z_i / (R_f \parallel R_g)} \quad (2)$$

[Equation 1](#) has a form identical to that for a voltage feedback amplifier with the differences occurring in the LG expression, [Equation 2](#). For an idealized treatment, set $Z_i=0$ which results in a very simple $LG = Z(s)/R_f$ (Derivation of the transfer function for the case where $Z_i=0$ is given in Application Note AN300-1). Using the $Z(s)$ (open-loop transimpedance gain) plot shown on the previous page and dividing by the recommended $R_f = 250\Omega$, yields a large loop gain at DC. As a result, Equation 1 shows that the closed-loop gain at DC is very close to $(1 + R_f/R_g)$.

At higher frequencies, the roll-off of $Z(s)$ determines the closed-loop frequency response which, ideally, is dependent only on R_f . **The specifications reported on the previous pages are therefore valid only for the specified $R = 250\Omega$.** Increasing R from 250 will decrease the loop gain and band width, while decreasing it will increase the loop gain possibly leading to inadequate phase margin and closed-loop peaking. Conversely, fixing R_f will hold the frequency response constant while the closed-loop gain can be adjusted using R_g .

The CLC400 departs from this idealized analysis to the extent that the inverting input impedance is finite. With the low quiescent power of the CLC400, $Z = 50\Omega$ leading to a drop in loop gain and bandwidth at high gain settlings, as given by Equation 2. The second term in Equation accounts for the division in feedback current that occurs between Z_i and $R_f \parallel R_g$ at the inverting node of the CLC400. This decrease in bandwidth can be circumvented as described in "Increasing Bandwidth at High Gains."

DC Accuracy and Noise

Since the two inputs for the CLC400 are quite dissimilar, the noise and offset error performance differs somewhat from that of a standard differential input amplifier. Specifically, the inverting input current noise is much larger than the non-inverting current noise. Also the two input bias currents are physically unrelated rendering bias current cancellation through matching of the inverting and non-inverting pin resistors ineffective.

In [Equation 3](#), the output offset is the algebraic sum of the equivalent input voltage and current sources that influence DC operation. Output noise is determined similarly except that a root-sum-of-squares replaces the algebraic sum. R_s is the non-inverting pin resistance.

$$\text{Output Offset } V_o = \pm IBN \times R_s (1 + R_f/R_g) \pm VIO (1 + R_f/R_g) \pm IBI \times R_f \quad (3)$$

An important observation is that for fixed R_f , offsets as referred to the input improve as the gain is increased (divide all terms by $1+R_f/R_g$). A similar result is obtained for noise where noise figure improves as a gain increases

Selecting Between the CLC400 or CLC401

The CLC400 is intended for gains of ± 1 to ± 8 while the CLC401 is designed for gains of ± 7 to ± 50 . Optimum performance is achieved with a feedback resistor of 250Ω with the CLC400 and 1.5Ω with the CLC401- this distinction may be important in transimpedance applications such as D/A buffering. Although the CLC400 can be used at higher gains, the CLC401 will provide a wider bandwidth because loop gain losses due to finite Z_i are lower with the larger CLC401 feedback resistor as explained above. On the other hand, the lower recommended feedback resistance of the CLC400 minimizes the output errors due to inverting input noise and bias currents.

Increasing Bandwidth At High Gains

Bandwidth may be increased at high closed-loop gains by adjusting R_f and R_g to make up for the losses in loop gain that occur at these high gain settlings due to current division at the inverting input. An approximate relationship may be obtained by holding the LG expression constant as the gain is changed from the design point used in the specifications (that is, $R_f = 250\Omega$ and $R_g = 250\Omega$). For the CLC400 this gives,

$$R_f = 350 - 50A_V \text{ and } R_g = \frac{350 - 50A_V}{A_V - 1} \quad (4)$$

where A_V is the non-inverting gain. Note that with $A_V = +2$ we get the specified $R_f = 250\Omega$, while at higher gains, a lower value gives stable performance with improved bandwidth.

Capacitive Feedback

Capacitive feedback should not be used with the CLC400 because of the potential for loop instability. See Application Note OA-7 for active filter realizations with the CLC400.

Offset Adjustment Pin

Pin 1 can be connected to a potentiometer as shown in [Figure 17](#) and used to adjust the input offset of the CLC400. Full range adjustment of $\pm 5V$ on pin 1 will yield a $\pm 10mV$ input offset adjustment range. Pin 1 should always be bypassed to ground with a ceramic capacitor located close to the package for best settling performance.

Printed Circuit Layout

As with any high frequency device, a good PCB layout will enhance performance. Ground plane construction and good power supply bypassing close to the package are critical to achieving full performance. In the non-inverting configuration, the amplifier is sensitive to stray capacitance to ground at the inverting input. Hence, the inverting node connections should be small with minimal coupling to the ground plane. Shunt capacitance across the feedback resistor should not be used to compensate for this effect.

Parasitic or load capacitance directly on the output will introduce additional phase shift in the loop degrading the loop phase margin and leading to frequency response peaking. A small series resistor before the capacitance effectively decouples this effect. The graphs on the preceding page illustrate the required resistor value and resulting performance vs. capacitance.

Precision buffered resistors (PRP8351 series from Precision Resistive Products) with low parasitic reactances were used to develop the data sheet specifications. Precision carbon composition resistors will also yield excellent results. Standard spirally-trimmed RN55D metal film resistors will work with a slight decrease in bandwidth due to their reactive nature at high frequencies.

Evaluation PC boards (part no. 730013 for through-hole and 730027 for SOIC) for the CLC400 are available.

REVISION HISTORY

Changes from Revision E (April 2013) to Revision F	Page
• Changed layout of National Data Sheet to TI format	9

IMPORTANT NOTICE

Texas Instruments Incorporated and its subsidiaries (TI) reserve the right to make corrections, enhancements, improvements and other changes to its semiconductor products and services per JESD46, latest issue, and to discontinue any product or service per JESD48, latest issue. Buyers should obtain the latest relevant information before placing orders and should verify that such information is current and complete. All semiconductor products (also referred to herein as "components") are sold subject to TI's terms and conditions of sale supplied at the time of order acknowledgment.

TI warrants performance of its components to the specifications applicable at the time of sale, in accordance with the warranty in TI's terms and conditions of sale of semiconductor products. Testing and other quality control techniques are used to the extent TI deems necessary to support this warranty. Except where mandated by applicable law, testing of all parameters of each component is not necessarily performed.

TI assumes no liability for applications assistance or the design of Buyers' products. Buyers are responsible for their products and applications using TI components. To minimize the risks associated with Buyers' products and applications, Buyers should provide adequate design and operating safeguards.

TI does not warrant or represent that any license, either express or implied, is granted under any patent right, copyright, mask work right, or other intellectual property right relating to any combination, machine, or process in which TI components or services are used. Information published by TI regarding third-party products or services does not constitute a license to use such products or services or a warranty or endorsement thereof. Use of such information may require a license from a third party under the patents or other intellectual property of the third party, or a license from TI under the patents or other intellectual property of TI.

Reproduction of significant portions of TI information in TI data books or data sheets is permissible only if reproduction is without alteration and is accompanied by all associated warranties, conditions, limitations, and notices. TI is not responsible or liable for such altered documentation. Information of third parties may be subject to additional restrictions.

Resale of TI components or services with statements different from or beyond the parameters stated by TI for that component or service voids all express and any implied warranties for the associated TI component or service and is an unfair and deceptive business practice. TI is not responsible or liable for any such statements.

Buyer acknowledges and agrees that it is solely responsible for compliance with all legal, regulatory and safety-related requirements concerning its products, and any use of TI components in its applications, notwithstanding any applications-related information or support that may be provided by TI. Buyer represents and agrees that it has all the necessary expertise to create and implement safeguards which anticipate dangerous consequences of failures, monitor failures and their consequences, lessen the likelihood of failures that might cause harm and take appropriate remedial actions. Buyer will fully indemnify TI and its representatives against any damages arising out of the use of any TI components in safety-critical applications.

In some cases, TI components may be promoted specifically to facilitate safety-related applications. With such components, TI's goal is to help enable customers to design and create their own end-product solutions that meet applicable functional safety standards and requirements. Nonetheless, such components are subject to these terms.

No TI components are authorized for use in FDA Class III (or similar life-critical medical equipment) unless authorized officers of the parties have executed a special agreement specifically governing such use.

Only those TI components which TI has specifically designated as military grade or "enhanced plastic" are designed and intended for use in military/aerospace applications or environments. Buyer acknowledges and agrees that any military or aerospace use of TI components which have **not** been so designated is solely at the Buyer's risk, and that Buyer is solely responsible for compliance with all legal and regulatory requirements in connection with such use.

TI has specifically designated certain components as meeting ISO/TS16949 requirements, mainly for automotive use. In any case of use of non-designated products, TI will not be responsible for any failure to meet ISO/TS16949.

Products

Audio	www.ti.com/audio
Amplifiers	amplifier.ti.com
Data Converters	dataconverter.ti.com
DLP® Products	www.dlp.com
DSP	dsp.ti.com
Clocks and Timers	www.ti.com/clocks
Interface	interface.ti.com
Logic	logic.ti.com
Power Mgmt	power.ti.com
Microcontrollers	microcontroller.ti.com
RFID	www.ti-rfid.com
OMAP Applications Processors	www.ti.com/omap
Wireless Connectivity	www.ti.com/wirelessconnectivity

Applications

Automotive and Transportation	www.ti.com/automotive
Communications and Telecom	www.ti.com/communications
Computers and Peripherals	www.ti.com/computers
Consumer Electronics	www.ti.com/consumer-apps
Energy and Lighting	www.ti.com/energy
Industrial	www.ti.com/industrial
Medical	www.ti.com/medical
Security	www.ti.com/security
Space, Avionics and Defense	www.ti.com/space-avionics-defense
Video and Imaging	www.ti.com/video

TI E2E Community

e2e.ti.com