

Dual, High Output, Video Amplifier

Check for Samples: [CLC5622](#)

FEATURES

- 130mA Output Current
- 0.05%, 0.03° Differential Gain, Phase
- 3.0mA/ch Supply Current
- 160MHz Bandwidth ($A_V = +2$)
- -90/-97dBc HD2/HD3 (1MHz)
- 18ns Settling to 0.05%
- 370V/ μ s Slew Rate
- Stable for Capacitive Loads up to 1000pf
- Single 5V or \pm 5V Supplies

APPLICATIONS

- Video Line Driver
- ADSL/HDSL Driver
- Coaxial Cable Driver
- UTP Differential Line Driver
- Transformer/coil Driver
- High Capacitive Load Driver
- Portable/Battery Powered Applications
- Differential A/D Driver

DESCRIPTION

The CLC5622 has a new output stage that delivers high output drive current (130mA), but consumes minimal quiescent supply current (3.0mA/ch) from a single 5V supply. Its current feedback architecture, fabricated in an advanced complementary bipolar process, maintains consistent performance over a wide range of gains and signal levels, and has a linear phase response up to one half of the -3dB frequency.

The CLC5622 offers 0.1dB gain flatness to 30MHz and differential gain and phase errors of 0.05% and 0.02°. These features are ideal for professional and consumer video applications.

The CLC5622 offers superior dynamic performance with a 160MHz small-signal bandwidth, 370V/ μ s slew rate and 4.4ns rise/fall times ($2V_{STEP}$). The combination of low quiescent power, high output current drive, and high speed performance make the CLC5622 well suited for many battery powered personal communication/computing systems.

The ability to drive low impedance, highly capacitive loads, makes the CLC5622 ideal for single ended cable applications. It also drives low impedance loads with minimum distortion. The CLC5622 will drive a 100 Ω load with only -95/-95dBc second/third harmonic distortion ($A_V = +2$, $V_{OUT} = 2V_{PP}$, $f = 1\text{MHz}$). With a 25 Ω load, and the same conditions, it produces only -72/-77dBc second/third harmonic distortion.

The CLC5622 can also be used for driving differential-input step-up transformers for applications such as Asynchronous Digital Subscriber Lines (ADSL) or High-Bit-Rate Digital Subscriber Lines (HDSL).

When driving the input of high resolution A/D converters, the CLC5622 provides excellent -90/-97dBc second/third harmonic distortion ($A_V = +2$, $V_{OUT} = 2V_{PP}$, $f = 1\text{MHz}$, $R_L = 1\text{k}\Omega$) and fast settling time.



Please be aware that an important notice concerning availability, standard warranty, and use in critical applications of Texas Instruments semiconductor products and disclaimers thereto appears at the end of this data sheet.

All trademarks are the property of their respective owners.

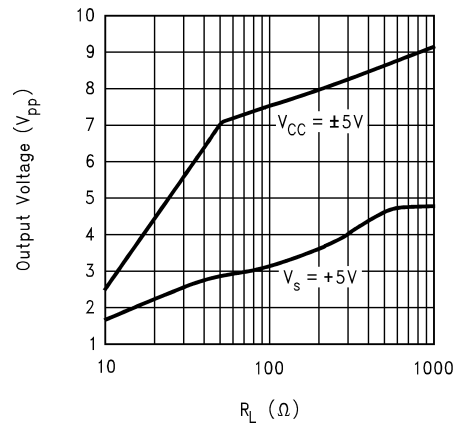
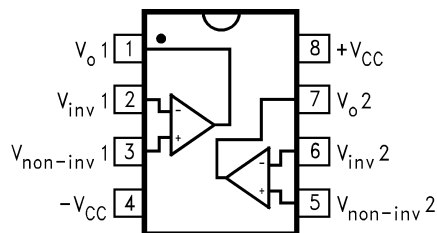

Figure 1. Maximum Output Voltage vs. R_L

CONNECTION DIAGRAM



Pinout
PDIP & SOIC
 See Package Numbers P and D

TYPICAL APPLICATION

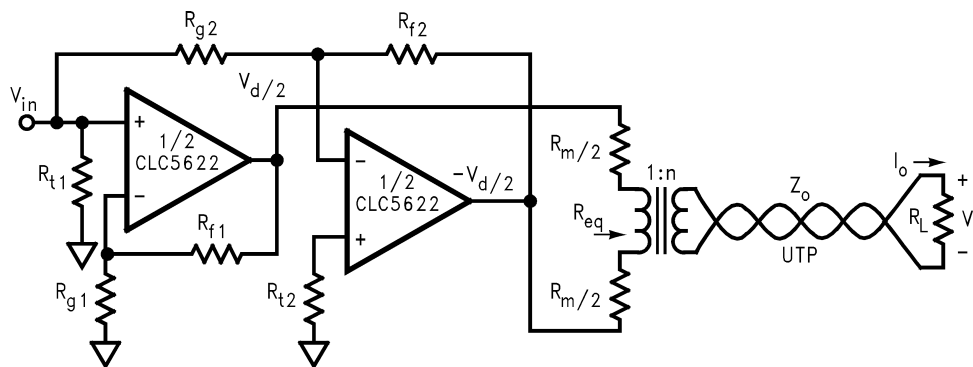

Differential Line Driver with Load Impedance Conversion



These devices have limited built-in ESD protection. The leads should be shorted together or the device placed in conductive foam during storage or handling to prevent electrostatic damage to the MOS gates.

ABSOLUTE MAXIMUM RATINGS⁽¹⁾⁽²⁾

Supply Voltage ($V_{CC}-V_{EE}$)	+14V
Output Current (See ⁽³⁾)	140mA
Common-Mode Input Voltage	V_{EE} to V_{CC}
Maximum Junction Temperature	+150°C
Storage Temperature Range	-65 to +150°C
Lead Temperature (soldering 10 sec)	+300°C
ESD (Human Body Model)	1000V

- (1) "Absolute Maximum Ratings" are those values beyond which the safety of the device cannot be ensured. They are not meant to imply that the devices should be operated at these limits. The table of "Electrical Characteristics" specifies conditions of device operation.
- (2) If Military/Aerospace specified devices are required, please contact the Texas Instruments Sales Office/Distributors for availability and specifications.
- (3) The short circuit current can exceed the maximum safe output current

OPERATING RATINGS

Thermal Resistance		
Package	(θ_{JC})	(θ_{JA})
PDIP	65°C/W	130°C/W
SOIC	50°C/W	145°C/W

+5V ELECTRICAL CHARACTERISTICS

($A_V = +2$, $R_f = 750\Omega$, $R_L = 100\Omega$, $V_S = +5V$ ⁽¹⁾, $V_{CM} = V_{EE} + (V_S/2)$, R_L tied to V_{CM} , unless specified)

Symbol	Parameter	Conditions	Typ	Min/Max Ratings ⁽²⁾				Units
Ambient Temperature		CLC5622IN/IM	+25°C	+25°C	0 to 70°C	-40 to 85°C		
Frequency Domain Response								
	-3dB Bandwidth	$V_O = 0.5V_{PP}$	130	100	90	85	MHz	
		$V_O = 2.0V_{PP}$	95	80	77	75	MHz	
	-0.1dB Bandwidth	$V_O = 0.5V_{PP}$	30	25	20	20	MHz	
	Gain Peaking	<200MHz, $V_O = 0.5V_{PP}$	0	0.5	0.9	1.3	dB	
	Gain Rolloff	<30MHz, $V_O = 0.5V_{PP}$	0.1	0.4	0.6	0.6	dB	
	Linear Phase Deviation	<30MHz, $V_O = 0.5V_{PP}$	0.15	0.3	0.4	0.4	deg	
	Differential Gain	NTSC, $R_L = 150\Omega$ to -1V	0.03	-	-	-	%	
	Differential Phase	NTSC, $R_L = 150\Omega$ to -1V	0.07	-	-	-	deg	
Time Domain Response								
	Rise and Fall Time	2V Step	4.5	6.0	6.4	6.8	ns	
	Settling Time to 0.05%	1V Step	17	25	40	60	ns	
	Overshoot	2V Step	11	15	18	18	%	
	Slew Rate	2V Step	280	195	165	150	V/ μ s	
Distortion And Noise Response								
	2nd Harmonic Distortion	$2V_{PP}, 1MHz$	-79	-76	-73	-73	dBc	
		$2V_{PP}, 1MHz; R_L = 1k\Omega$	-80	-78	-75	-75	dBc	
		$2V_{PP}, 5MHz$	-66	-60	-58	-58	dBc	
	3rd Harmonic Distortion	$2V_{PP}, 1MHz$	-85	-82	-79	-79	dBc	
		$2V_{PP}, 1MHz; R_L = 1k\Omega$	-83	-81	-78	-78	dBc	
		$2V_{PP}, 5MHz$	-65	-62	-60	-60	dBc	
	Equivalent Input Noise							
	Voltage (e_{ni})	>1MHz	3.4	4.4	4.9	4.9	nV/ \sqrt{Hz}	
	Non-Inverting Current (i_{bn})	>1MHz	6.3	8.2	9.0	9.0	pA/ \sqrt{Hz}	

(1) $V_S = V_{CC} - V_{EE}$

(2) Min/max ratings are based on product characterization and simulation. Individual parameters are tested as noted. Outgoing quality levels are determined from tested parameters.

+5V ELECTRICAL CHARACTERISTICS (continued)
 $(A_V = +2, R_f = 750\Omega, R_L = 100\Omega, V_S = +5V^{(1)}, V_{CM} = V_{EE} + (V_S/2), R_L \text{ tied to } V_{CM}, \text{ unless specified})$

Symbol	Parameter	Conditions	Typ	Min/Max Ratings ⁽²⁾			Units
	Inverting Current (I_{bn})	>1MHz	8.7	11.3	12.4	12.4	pA/ $\sqrt{\text{Hz}}$
	Crosstalk (Input Referred)	10MHz, 1V _{PP}	-72	-	-	-	dB
Static, DC Performance							
	Input Offset Voltage ⁽³⁾		1	4	6	6	mV
	Average Drift		8	-	-	-	$\mu\text{V}/^\circ\text{C}$
	Input Bias Current (Non-Inverting) ⁽³⁾		6	18	22	24	μA
	Average Drift		40	-	-	-	nA/ $^\circ\text{C}$
	Input Bias Current (Inverting) ⁽³⁾		6	14	16	17	μA
	Average Drift		25	-	-	-	nA/ $^\circ\text{C}$
	Power Supply Rejection Ratio	DC	48	45	43	43	dB
	Common Mode Rejection Ratio	DC	47	45	43	43	dB
	Supply Current ⁽³⁾	$R_L = \infty$	3.0	3.4	3.6	3.6	mA
Miscellaneous Performance							
	Input Resistance (Non-Inverting)		0.36	0.26	0.23	0.23	M Ω
	Input Capacitance (Non-Inverting)		1.8	2.75	2.75	2.75	pF
	Input Voltage Range, High		4.2	4.1	4.1	4.0	V
	Input Voltage Range, Low		0.8	0.9	0.9	1.0	V
	Output Voltage Range, High	$R_L = 100\Omega$	4.0	3.9	3.9	3.8	V
	Output Voltage Range, Low	$R_L = 100\Omega$	1.0	1.1	1.1	1.2	V
	Output Voltage Range, High	$R_L = \infty$	4.1	4.0	4.0	3.9	V
	Output Voltage Range, Low	$R_L = \infty$	0.9	1.0	1.0	1.1	V
	Output Current ⁽⁴⁾		100	80	65	40	mA
	Output Resistance, Closed Loop	DC	70	105	105	140	m Ω

(3) A-J-level: spec. is 100% tested at +25°C.

(4) The short circuit current can exceed the maximum safe output current

±5V ELECTRICAL CHARACTERISTICS
 $(A_V = +2, R_f = 750\Omega, R_L = 100\Omega, V_{CM} = \pm 5V, \text{ Unless Specified})$

Symbol	Parameter	Conditions	Typ	Min/Max Ratings ⁽¹⁾			Units
	Ambient Temperature	CLC5622IN/IM	+25°C	+25°C	0 to 70°C	-40 to 85°C	
Frequency Domain Response							
	-3dB Bandwidth	$V_O = 1.0V_{PP}$	160	135	120	115	MHz
		$V_O = 4.0V_{PP}$	75	60	57	55	MHz
	-0.1dB Bandwidth	$V_O = 1.0V_{PP}$	30	25	20	20	MHz
	Gain Peaking	<200MHz, $V_O = 1.0V_{PP}$	0	1.5	0.9	1.3	dB
	Gain Roll-off	<30MHz, $V_O = 1.0V_{PP}$	0.1	0.2	0.3	0.3	dB
	Linear Phase Deviation	<30MHz, $V_O = 1.0V_{PP}$	0.15	0.3	0.4	0.4	deg
	Differential Gain	NTSC, $R_L = 150\Omega$	0.05	0.06	-	-	%
	Differential Phase	NTSC, $R_L = 150\Omega$	0.03	0.06	-	-	deg
Time Domain Response							
	Rise and Fall Time	2V Step	4.4	5.8	6.2	6.8	ns
	Settling Time to 0.05%	2V Step	18	25	40	60	ns
	Overshoot	2V Step	19	21	23	24	%
	Slew Rate	2V Step	370	280	260	240	V/ μs

(1) Min/max ratings are based on product characterization and simulation. Individual parameters are tested as noted. Outgoing quality levels are determined from tested parameters.

±5V ELECTRICAL CHARACTERISTICS (continued)

($A_V = +2$, $R_f = 750\Omega$, $R_L = 100\Omega$, $V_{CM} = \pm 5V$, Unless Specified)

Symbol	Parameter	Conditions	Typ	Min/Max Ratings ⁽¹⁾			Units
Distortion And Noise Response							
	2nd Harmonic Distortion	2V _{PP} , 1MHz	-95	-88	-385	-385	dBc
		2V _{PP} , 1MHz; R _L = 1kΩ	-90	-88	-85	-85	dBc
		2V _{PP} , 5MHz	-74	-66	-64	-64	dBc
	3rd Harmonic Distortion	2V _{PP} , 1MHz	-95	-91	-88	-88	dBc
		2V _{PP} , 1MHz; R _L = 1kΩ	-97	-93	-90	-90	dBc
		2V _{PP} , 5MHz	-73	-64	-62	-62	dBc
	Equivalent Input Noise						
	Voltage (e _{ni})	>1MHz	3.4	4.4	4.9	4.9	nV/√Hz
	Non-Inverting Current (i _{bn})	>1MHz	6.3	8.2	9.0	9.0	pA/√Hz
	Inverting Current (i _{bi})	>1MHz	8.7	11.3	12.4	12.4	pA/√Hz
	Crosstalk (Input Referred)	10MHz, 1V _{PP}	-72	-	-	-	dB
Static, DC Performance							
	Input Offset Voltage		1	6	7	8	mV
	Average Drift		10	-	-	-	μV/°C
	Input Bias Current (Non-Inverting)		8	18	23	25	μA
	Average Drift		40	-	-	-	nA/°C
	Input Bias Current (Inverting)		9	24	28	28	μA
	Average Drift		30	-	-	-	nA/°C
	Power Supply Rejection Ratio	DC	48	45	43	43	dB
	Common Mode Rejection Ratio	DC	48	46	44	44	dB
	Supply Current (Per Channel)	R _L = ∞	3.2	3.8	4.0	4.0	mA
Miscellaneous Performance							
	Input Resistance (Non-Inverting)		0.48	0.34	0.31	0.31	MΩ
	Input Capacitance (Non-Inverting)		1.45	2.15	2.15	2.15	pF
	Common-Mode Input Range		±4.2	±4.1	±4.1	±4.0	V
	Output Voltage Range	R _L = 100Ω	±3.8	±3.6	±3.6	±3.5	V
	Output Voltage Range	R _L = ∞	±4.0	±3.8	±3.8	±3.7	V
	Output Current ⁽²⁾		130	100	80	50	mA
	Output Resistance, Closed Loop	DC	60	90	90	120	mΩ

(2) The short circuit current can exceed the maximum safe output current

+5V TYPICAL PERFORMANCE CHARACTERISTICS

($A_V = +2$, $R_f = 750\Omega$, $R_L = 100\Omega$, $V_S = +5V$ ($V_S = V_{CC} - V_{EE}$), $V_{CM} = V_{EE} + (V_S/2)$, R_L tied to V_{CM} , unless specified).

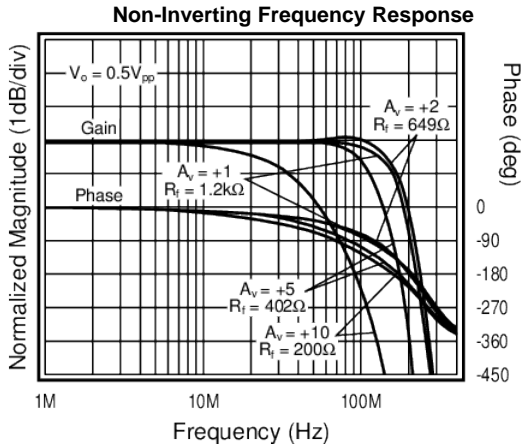

Figure 2.

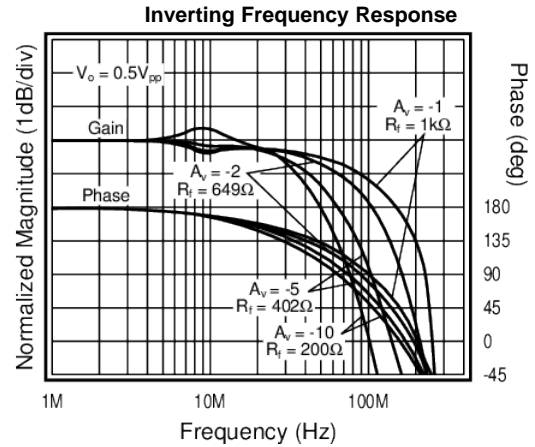

Figure 3.

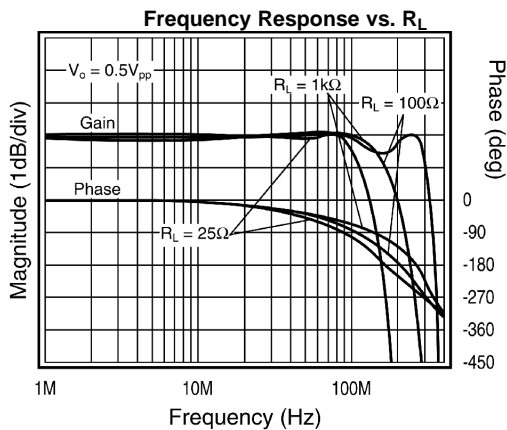

Figure 4.

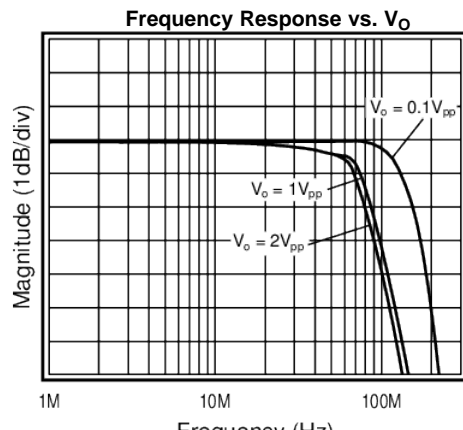

Figure 5.

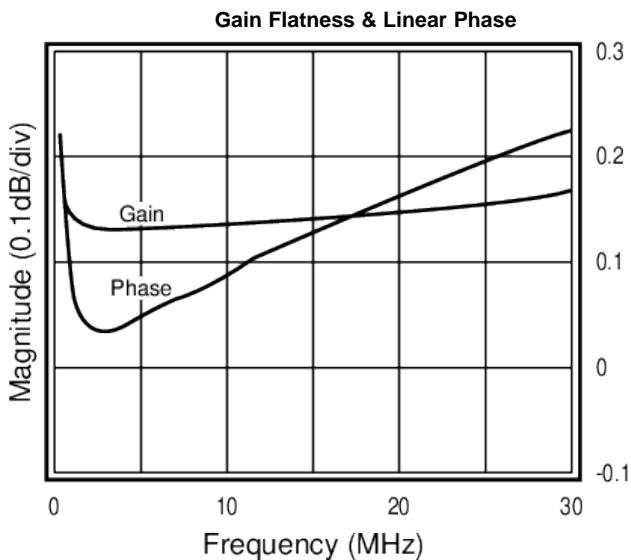

Figure 6.

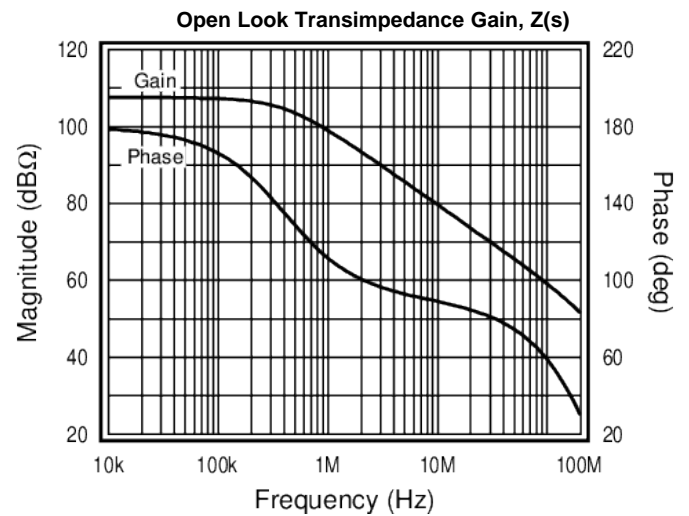

Figure 7.

+5V TYPICAL PERFORMANCE CHARACTERISTICS (continued)

($A_V = +2$, $R_f = 750\Omega$, $R_L = 100\Omega$, $V_S = +5V$ ($V_S = V_{CC} - V_{EE}$), $V_{CM} = V_{EE} + (V_S/2)$, R_L tied to V_{CM} , unless specified).

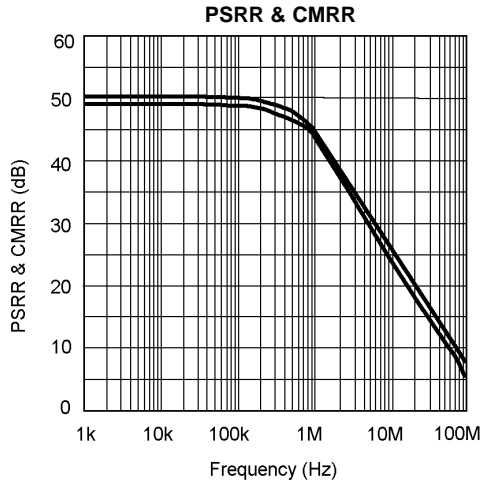

Figure 8.

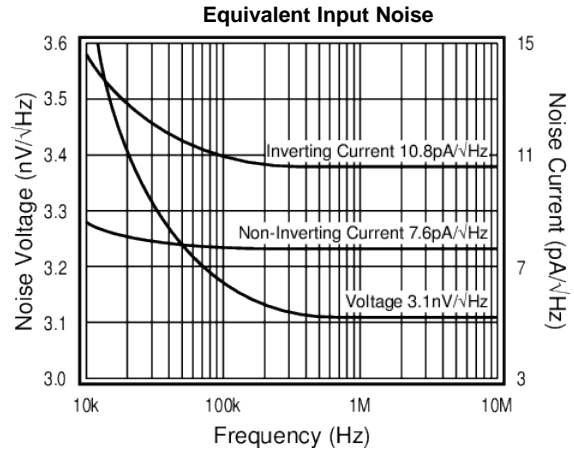

Figure 9.

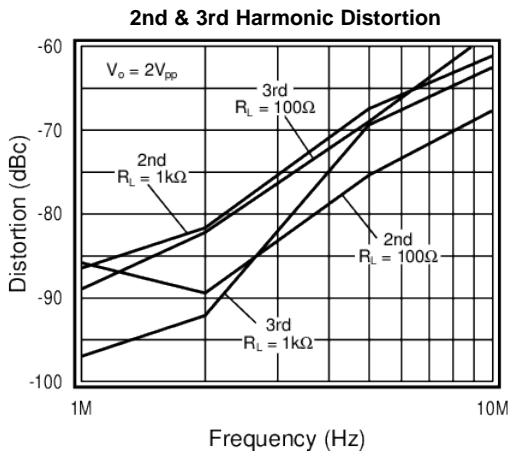

Figure 10.

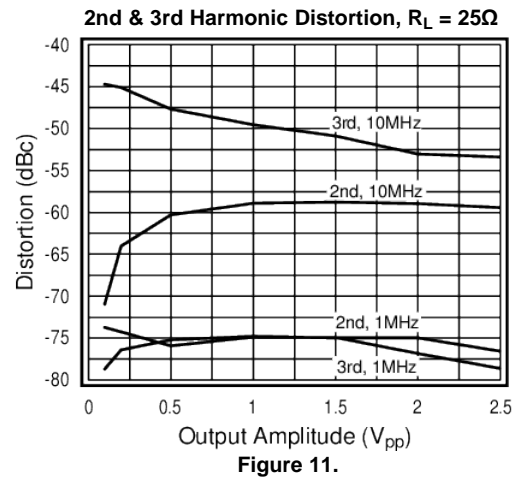

Figure 11.

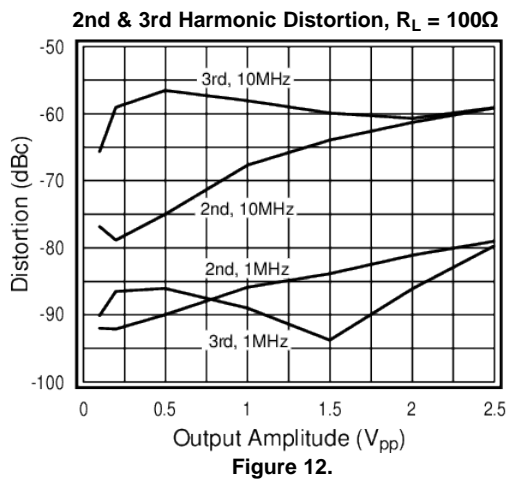

Figure 12.

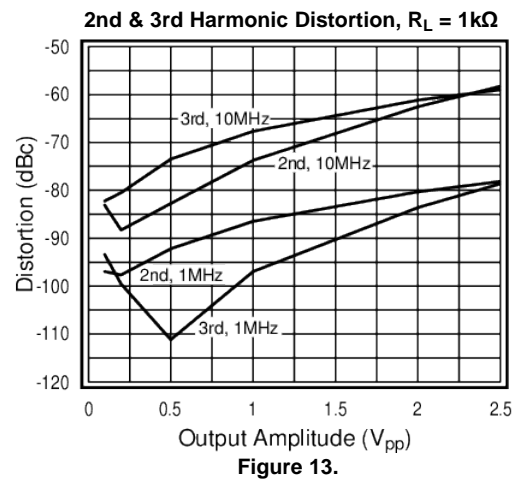

Figure 13.

+5V TYPICAL PERFORMANCE CHARACTERISTICS (continued)

($A_V = +2$, $R_f = 750\Omega$, $R_L = 100\Omega$, $V_S = +5V$ ($V_S = V_{CC} - V_{EE}$), $V_{CM} = V_{EE} + (V_S/2)$, R_L tied to V_{CM} , unless specified).

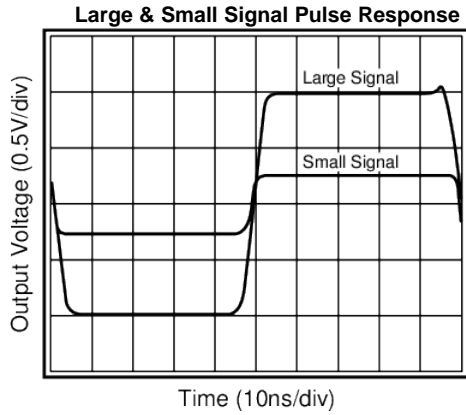

Figure 14.

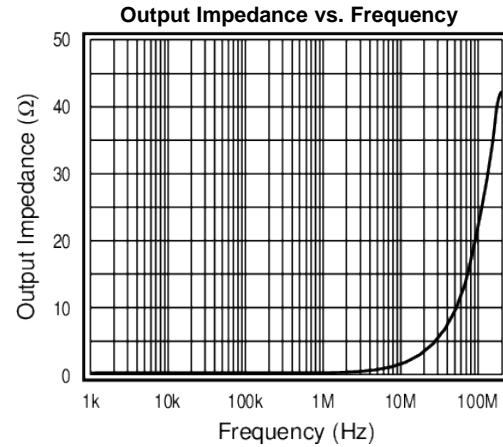

Figure 15.

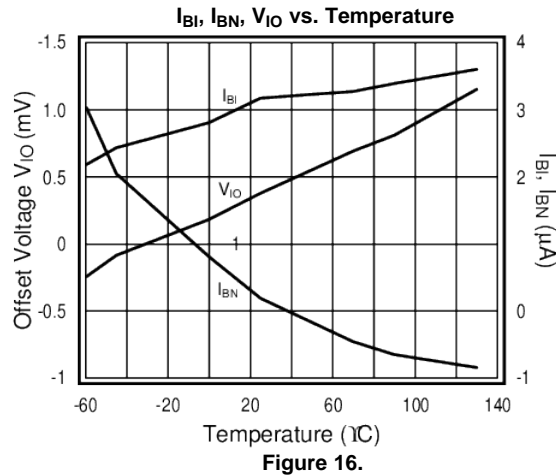

Figure 16.

±5V TYPICAL PERFORMANCE

($A_v = +2$, $R_f = 750\Omega$, $R_L = 100\Omega$, $V_{CC} = \pm 5V$, unless specified)

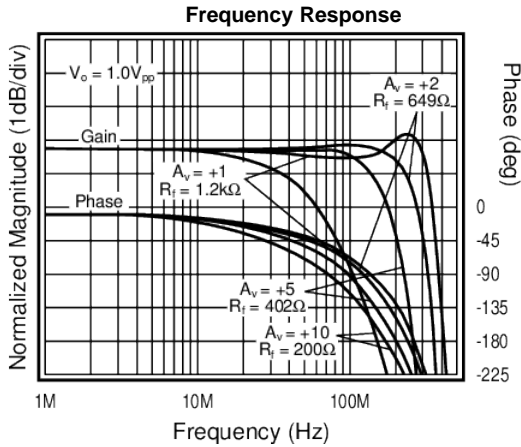

Figure 17.

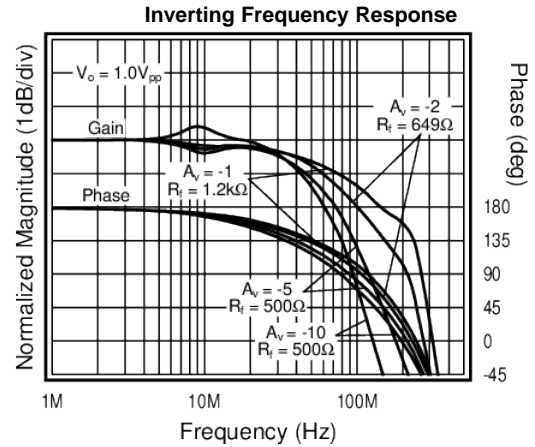

Figure 18.

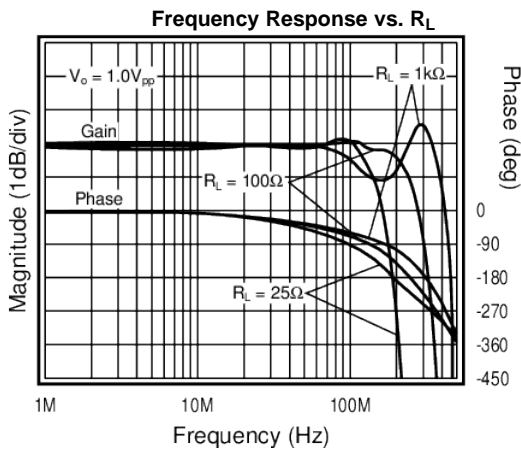

Figure 19.

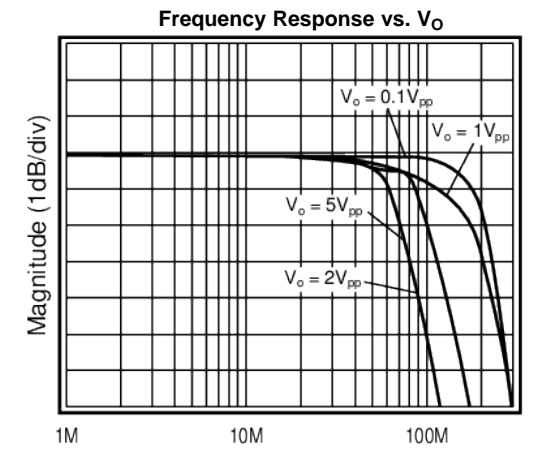

Figure 20.

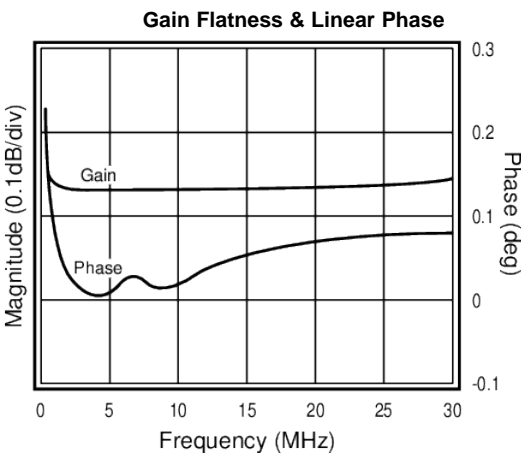

Figure 21.

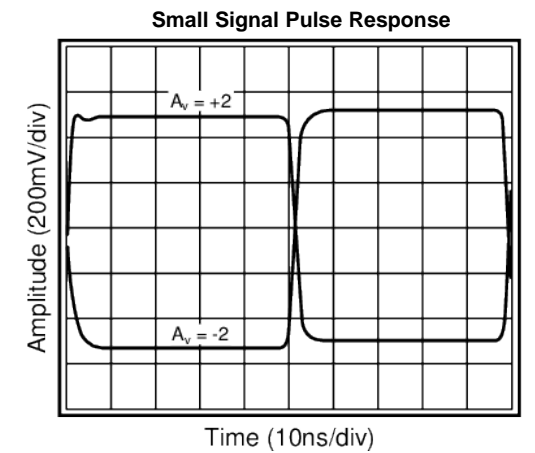

Figure 22.

±5V TYPICAL PERFORMANCE (continued)

($A_v = +2$, $R_f = 750\Omega$, $R_L = 100\Omega$, $V_{CC} = \pm 5V$, unless specified)

Large Signal Pulse Response

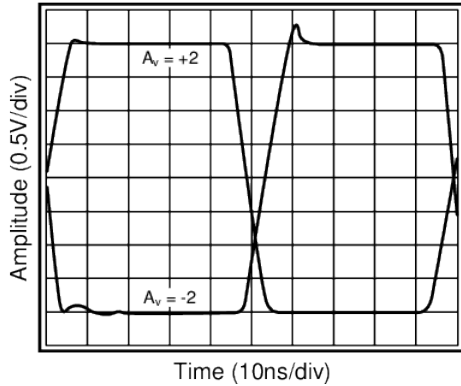

Figure 23.

Differential Gain and Phase

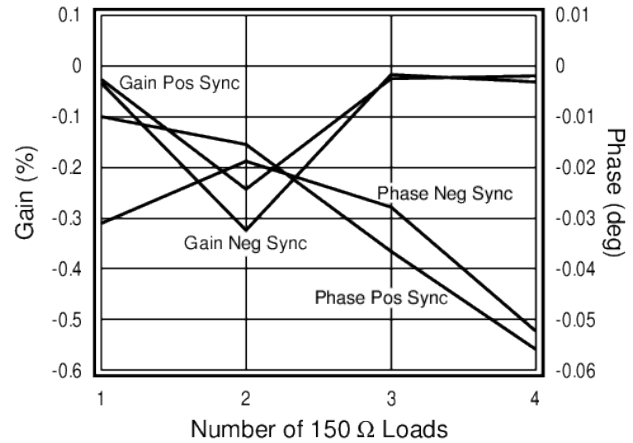

Figure 24.

2nd & 3rd Harmonic Distortion

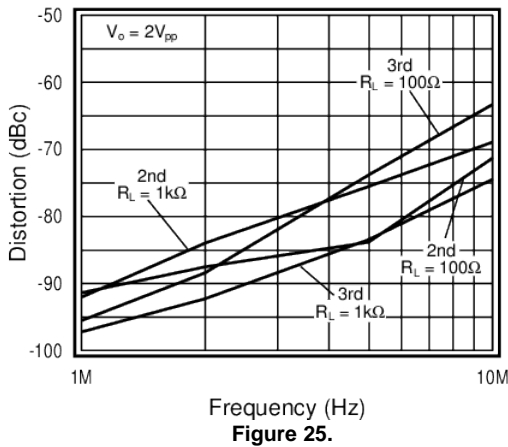

Figure 25.

2nd & 3rd Harmonic Distortion, $R_L = 25\Omega$

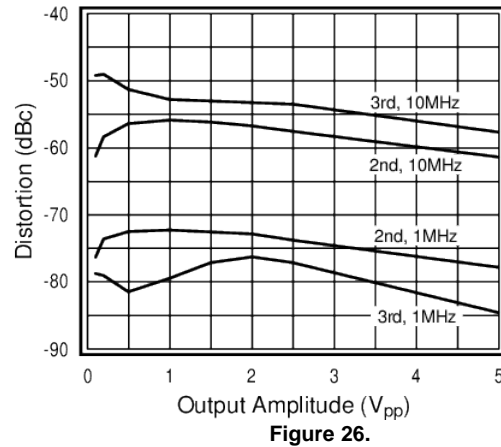

Figure 26.

2nd & 3rd Harmonic Distortion, $R_L = 100\Omega$

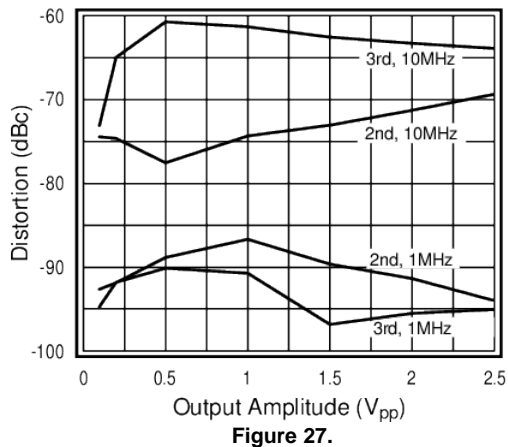

Figure 27.

2nd & 3rd Harmonic Distortion, $R_L = 1k\Omega$

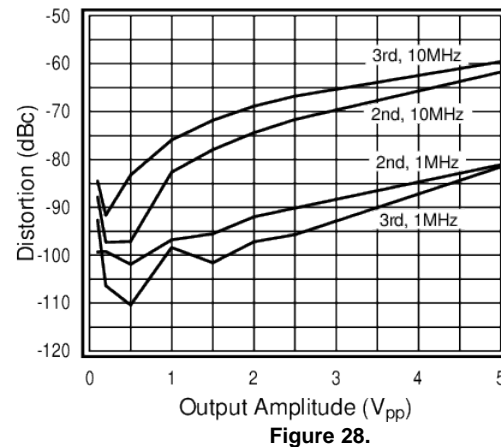

Figure 28.

±5V TYPICAL PERFORMANCE (continued)

($A_V = +2$, $R_f = 750\Omega$, $R_L = 100\Omega$, $V_{CC} = \pm 5V$, unless specified)

Short Term Settling Time

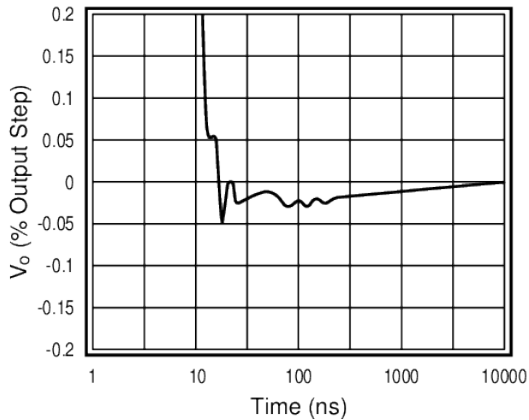

Figure 29.

Long Term Settling Time

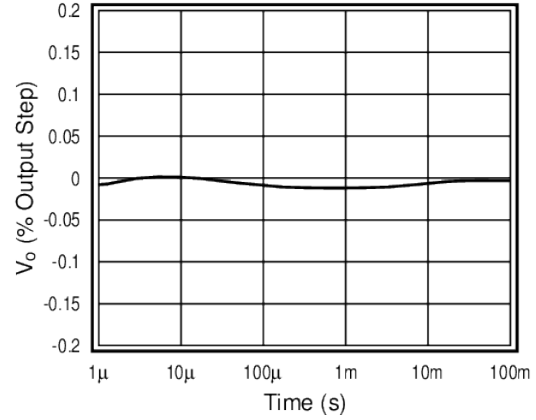

Figure 30.

I_{BI}, I_{BN}, V_{OS} vs. Temperature

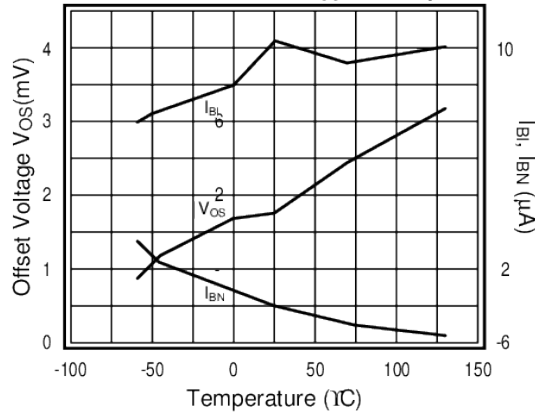

Figure 31.

Channel Matching

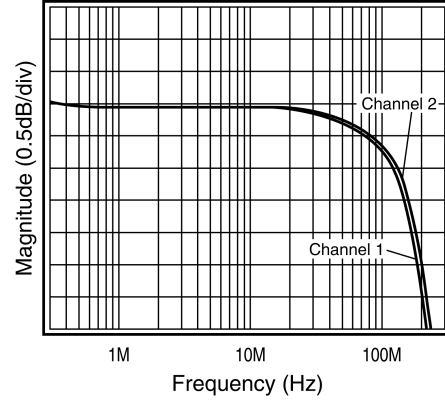

Figure 32.

Input Referred Crosstalk

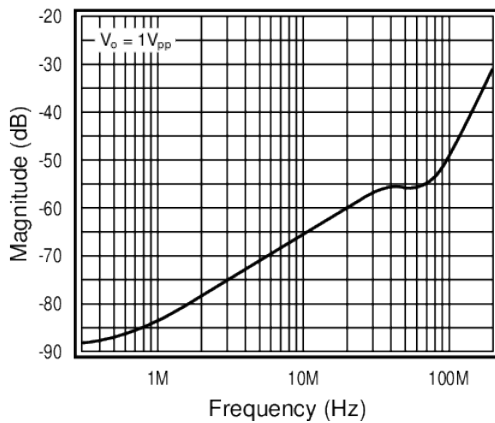

Figure 33.

Pulse Crosstalk

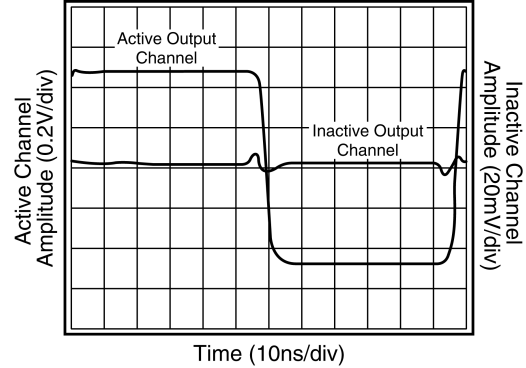

Figure 34.

APPLICATION DIVISION

CLC5622 OPERATION

The CLC5622 is a current feedback amplifier fabricated in an advanced complementary bipolar process. The CLC5622 operates from a single 5V supply or dual $\pm 5V$ supplies. Operating from a single supply, the CLC5622 has the following features:

- Provides 100mA of output current while consuming 15mW of power
- Offers low $-80/-83$ dB 2nd and 3rd harmonic distortion
- Provides $BW > 80$ MHz and 1MHz distortion < -75 dBc at $V_O = V_{PP}$

The CLC5622 performance is further enhanced in $\pm 5V$ supply applications as indicated in the [+5V ELECTRICAL CHARACTERISTICS](#) table and [+5V ELECTRICAL CHARACTERISTICS](#) plots.

CURRENT FEEDBACK AMPLIFIERS

Some of the key features of current feedback technology are:

- Independence of AC bandwidth and voltage gain
- Inherently stable at unity gain
- Adjustable frequency response with feedback resistor
- High slew rate
- Fast Settling

Current feedback operation can be described using a simple equation. The voltage gain for a non-inverting or inverting current feedback amplifier is approximated by [Equation 1](#).

$$\frac{V_o}{V_{in}} = \frac{A_v}{1 + \frac{R_f}{Z(j\omega)}}$$

where

- A_v is the closed loop DC voltage gain
- R_f is the feedback resistor
- $Z(j\omega)$ is the CLC5622's open loop transimpedance gain
- $Z(j\omega)R_f$ is the loop gain

(1)

The denominator of [Equation 1](#) is approximately equal to 1 at low frequencies. Near the -3 dB corner frequency, the interaction between R_f and $Z(j\omega)$ dominates the circuit performance. The value of the feedback resistor has a large affect on the circuits performance. Increasing R_f has the following affects:

- Decreases loop gain
- Decreases bandwidth
- Reduces gain peaking
- Lowers pulse response overshoot
- Affects frequency response phase linearity

Refer to the [Feedback Resistor Selection](#) section for more details on selecting a feedback resistor value.

CLC5622 Design Information

Single Supply Operation ($V_{CC} = +5V$, $V_{EE} = GND$)

The specifications given in the [+5V ELECTRICAL CHARACTERISTICS](#) table for single supply operation are measured with a common mode voltage (V_{cm}) of 2.5V. V_{cm} is the voltage around which the inputs are applied and the output voltages are specified.

Operating from a single +5V supply, the Common Mode Input Range (CMIR) of the CLC5622 is typically +0.8V to +4.2V. The typical output range with $R_L = 100\Omega$ is +1.0V to +4.0V.

For single supply DC coupled operation, keep input signal levels above 0.8V DC. For input signals that drop below 0.8V DC, AC coupling and level shifting the signal are recommended. The non-inverting and inverting configurations for both input conditions are illustrated in the following 2 sections.

DC Coupled Single Supply Operation

Figure 35 and Figure 36 show the recommended non-inverting and inverting configurations for input signals that remain above 0.8V DC. Note: R_f , R_L , and R_g are tied to V_{cm} for minimum power consumption and maximum output swing.

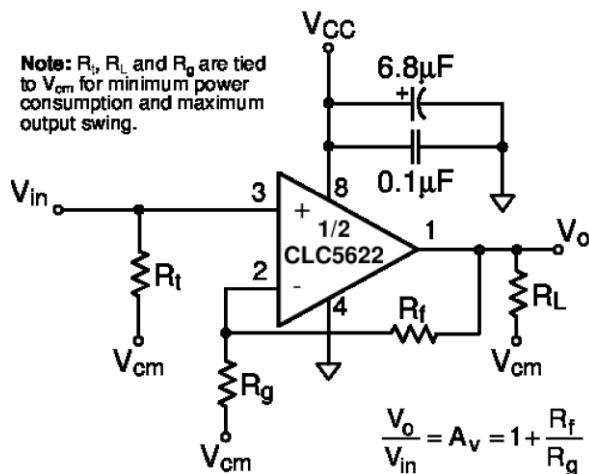

Figure 35. Non-Inverting Configuration

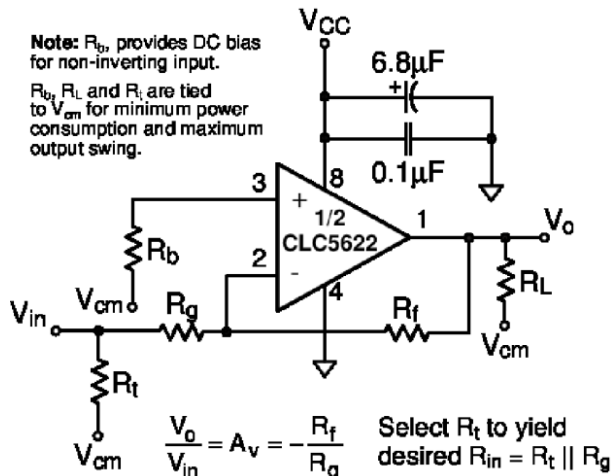

Figure 36. Inverting Configuration

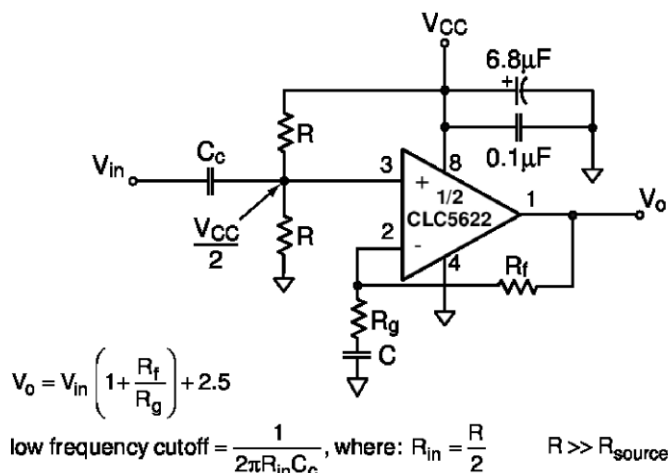

Figure 37. AC Coupled Non-Inverting Configuration

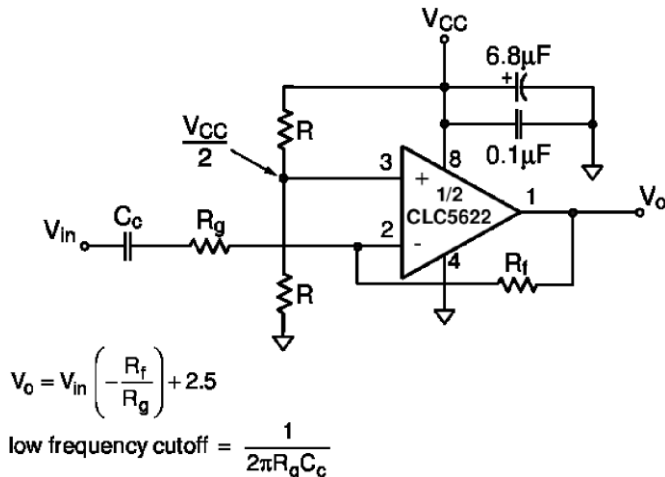

Figure 38. Dual Supply Non-Inverting Configuration

AC Coupled Single Supply Operation

Figure 37 and Figure 38 show possible non-inverting and inverting configurations for input signals that go below 0.8V DC. The input is AC coupled to prevent the need for level shifting the input signal at the source. The resistive voltage divider biases the non-inverting input to $V_{CC} \div 2 = 2.5V$ (For $V_{CC} = +5V$).

Dual Supply Operation

The CLC5622 operates on dual supplies as well as single supplies. The non-inverting and inverting configurations are shown in Figure 39 and Figure 40.

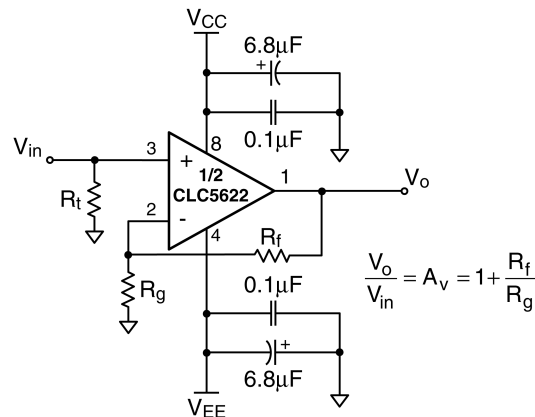

Figure 39. Dual Supply Non-Inverting Configuration

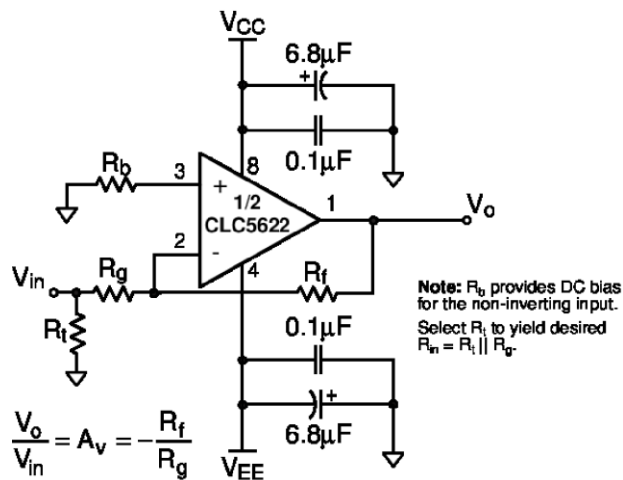

Figure 40. Dual Supply Inverting Configuration

Feedback Resistor Selection

The feedback resistor, R_f , affects the loop gain and frequency response of a current feedback amplifier. Optimum performance of the CLC5622, at a gain of $+2V/V$, is achieved with R_f equal to 750Ω . The frequency response plots in the [Typical Performance](#) sections illustrate the recommended R_f for several gains. These recommended values of R_f provide the maximum bandwidth with minimal peaking. Within limits, R_f can be adjusted to optimize the frequency response.

- Decrease R_f to peak frequency response and extend bandwidth
- Increase R_f to roll off frequency response and compress bandwidth

As a rule of thumb, if the recommended R_f is doubled, then the bandwidth will be cut in half.

Unity Gain Operation

The recommended R_f for unity gain ($+1V/V$) operation is $1.2k\Omega$. R_g is left open. Parasitic capacitance at the inverting node may require a slight increase in R_f to maintain a flat frequency response.

Load Termination

The CLC5622 can source and sink near equal amounts of current. For optimum performance, the load should be tied to V_{CM} .

Driving Cables and Capacitive Loads

When driving cables, double termination is used to prevent reflections. For capacitive load applications, a small series resistor at the output of the CLC5622 will improve stability and settling performance. The **Frequency Response vs. C_L** plot, shown below in Figure 41, gives the recommended series resistance value for optimum flatness at various capacitive loads.

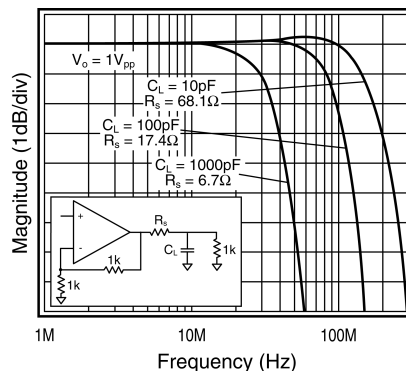

Figure 41. Frequency Response vs. C_L

Transmission Line Matching

One method for matching the characteristic impedance (Z_0) of a transmission line or cable is to place the appropriate resistor at the input or output of the amplifier. Figure 42 shows typical inverting and non-inverting circuit configurations for matching transmission lines.

Non-inverting gain applications:

- Connect R_3 directly to ground.
- Make R_1 , R_2 , R_6 , and R_7 equal to Z_0 .
- Use R_3 to isolate the amplifier from reactive loading caused by the transmission line, or by parasitics.

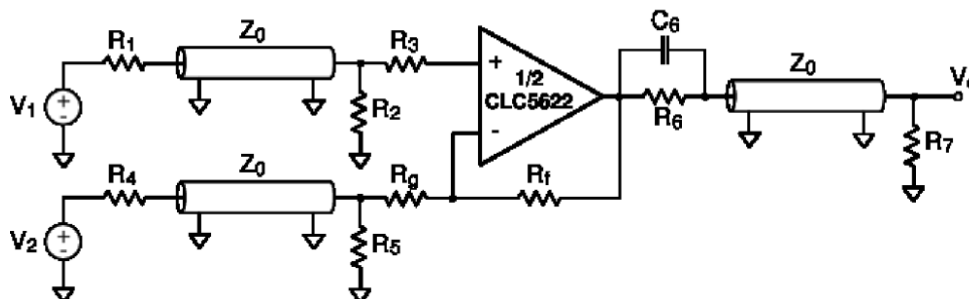

Figure 42. Transmission Line Matching

Inverting gain applications:

- Connect R_3 directly to ground.
- Make the resistors R_4 , R_6 , and R_7 equal to Z_0 .
- Make $R_5 \parallel R_g = Z_0$

The input and output matching resistors attenuate the signal by a factor of 2, therefore additional gain is needed. Use C_6 to match the output transmission line over a greater frequency range. C_6 compensates for the increase of the amplifier's output impedance with frequency.

Power Dissipation

Follow these steps to determine the power consumption of the CLC5622.

1. Calculate the quiescent (no-load) power: $P_{amp} = I_{CC} (V_{CC} - V_{EE})$
2. Calculate the RMS power at the output stage: $P_0 = (V_{CC} - V_{load}) (I_{load})$, where V_{load} and I_{load} are the RMS voltage and current across the external load.
3. Calculate the total RMS power: $P_t = P_{amp} + P_0$

The maximum power that the PDIP and SOIC packages can dissipate at a given temperature is illustrated in [Figure 43](#). The power derating curve for any CLC5622 package can be derived by utilizing the following equation:

$$\frac{(150^\circ - T_{amb})}{\theta_{JA}}$$

where

- T_{amb} =Ambient temperature ($^\circ\text{C}$)
 - θ_{JA} =Thermal resistance, from junction to ambient, for a given package ($^\circ\text{C}/\text{W}$)
- (2)

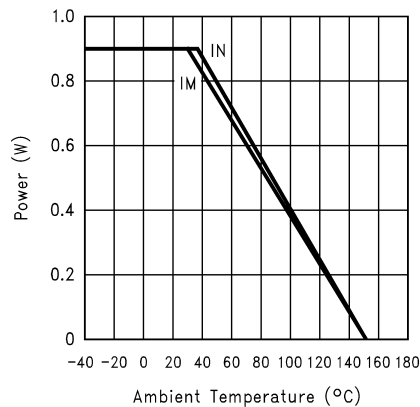

Figure 43. Power Derating Curves

Layout Considerations

A proper printed circuit layout is essential for achieving high frequency performance. TI provides evaluation boards for the CLC5622 (CLC730038-PDIP, CLC730036-SOIC) and suggests their use as a guide for high frequency layout and as an aid for device testing and characterization.

General layout and supply bypassing play major roles in high frequency performance. Follow these steps below as a basis for high frequency layout:

- Include 6.8 μF tantalum and 0.1 μF ceramic capacitors on both supplies.
- Place the 6.8 μF capacitors within 0.75 inches of the power pins.
- Place the 0.1 μF capacitors less than 0.1 inches from the power pins.
- Remove the ground plane under and around the part, especially near the input and output pins to reduce parasitic capacitance.
- Minimize all trace lengths to reduce series inductances.
- Use flush-mount printed circuit board pins for prototyping, never use high profile PDIP sockets.

Evaluation Board Information

A data sheet is available for the CLC730038/CLC730036 evaluation boards. The evaluation board data sheet provides:

- Evaluation board schematics
- Evaluation board layouts
- General information about the boards

The evaluation boards are designed to accommodate dual supplies. The boards can be modified to provide single supply operation. For best performance; 1) do not connect the unused supply, 2) ground the unused supply pin.

SPICE Models

SPICE models provide a means to evaluate amplifier designs. Free SPICE models are available for TI's monolithic amplifiers that:

- Support Berkeley SPICE 2G and its many derivatives
- Reproduces typical DC, AC, Transient, and Noise performance
- Support room temperature simulations

The *readme* file that accompanies the diskette lists released models, and provides a list of modeled parameters. The application note OA-18, Simulation SPICE Models for TI's Op Amps, contains schematics and a reproduction of the *readme* file.

Application Circuits Single Supply Cable Driver

The typical application shown below shows one of the CLC5622 amplifiers driving 10m of 75Ω coaxial cable. The CLC5622 is set for a gain of +2V/V to compensate for the divide-by-two voltage drop at V_O .

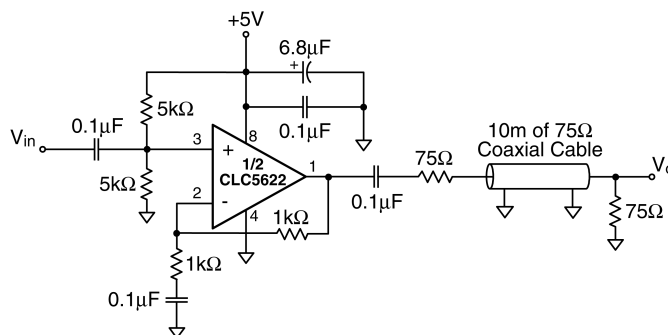

Figure 44. Single Supply Cable Driver

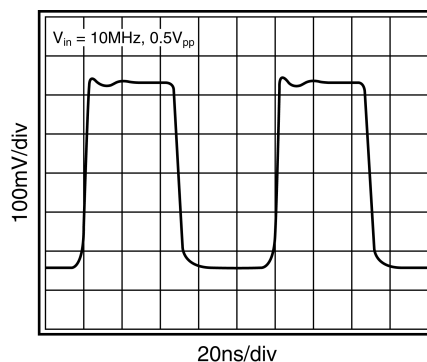

Figure 45. Response After 10m of Cable

Single Supply Lowpass Filter

Figure 46 and Figure 47 illustrate a lowpass filter and design equations. The circuit operates from a single supply of +5V. The voltage divider biases the non-inverting input to 2.5V. And the input is AC coupled to prevent the need for level shifting the input signal at the source. Use the design equations to determine R_1 , R_2 , C_1 , and C_2 based on the desired Q and corner frequency.

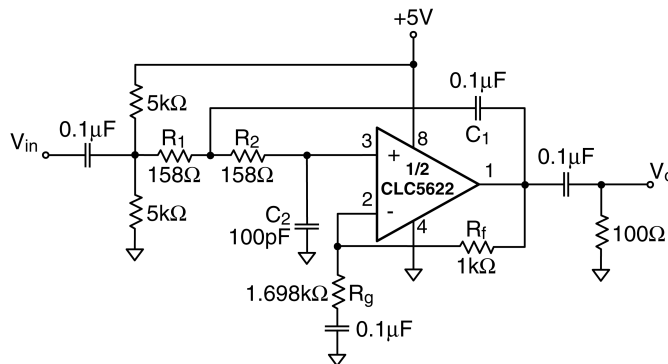

Figure 46. Lowpass Filter Topology

$$\text{Gain} = K = 1 + \frac{R_f}{R_g}$$

$$\text{Corner frequency} = \omega_c = \sqrt{\frac{1}{R_1 R_2 C_1 C_2}}$$

$$Q = \frac{1}{\sqrt{\frac{R_2 C_2}{R_1 C_1}} + \sqrt{\frac{R_1 C_2}{R_2 C_1}} + (1-K) \sqrt{\frac{R_1 C_1}{R_2 C_2}}}$$

For $R_1 = R_2 = R$ and $C_1 = C_2 = C$

$$\omega_c = \frac{1}{RC}$$

$$Q = \frac{1}{(3-K)}$$

Figure 47. Design Equations

This example illustrates a lowpass filter with $Q=0.707$ and corner frequency $f_c/10\text{MHz}$. A Q of the 0.707 was chosen to achieve a maximally flat, Butterworth response. Figure 48 indicates the filter response.

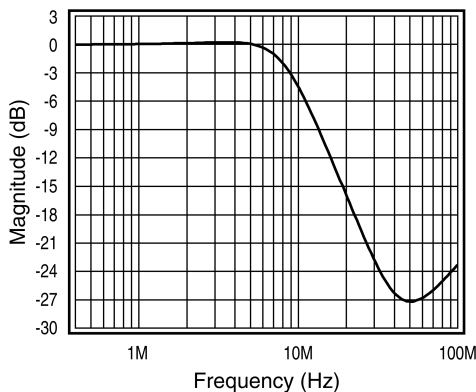

Figure 48. Lowpass Response

Differential Line Driver With Load Impedance Conversion

The circuit shown in the [TYPICAL APPLICATION](#) schematic on the front page and in [Figure 49](#), operates as a differential line driver. The transformer converts the load impedance to a value that best matches the CLC5622's output capabilities. The single-ended input signal is converted to a differential signal by the CLC5622. The line's characteristic impedance is matched at both the input and the output. The schematic shows Unshielded Twisted Pair for the transmission line; other types of lines can also be driven.

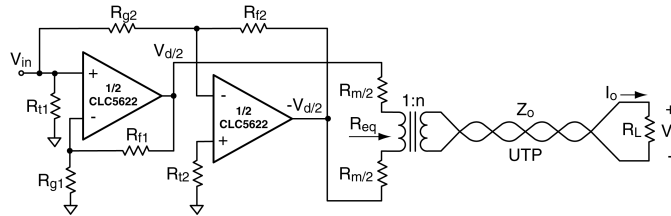

Figure 49. Differential Line Driver with Load Impedance Conversion

Set up the CLC5622 as a difference amplifier:

$$\frac{V_d}{V_{in}} = 2 \cdot \left(1 + \frac{R_{f1}}{R_{g1}} \right) = 2 \cdot \frac{R_{f2}}{R_{g2}} \quad (3)$$

Make the best use of the CLC5622's output drive capability as follows:

$$R_m + R_{eq} = \frac{2 \cdot V_{max}}{I_{max}}$$

where

- R_{eq} is the transformed value of the load impedance
- V_{max} is the Output Voltage Range
- I_{max} is the maximum Output Current

(4)

Match the line's characteristic impedance:

$$R_L = Z_o$$

$$R_m = R_{eq}$$

$$n = \sqrt{\frac{R_L}{R_{eq}}} \quad (5)$$

Select the transformer so that it loads the line with a value very near Z_o over frequency range. The output impedance of the CLC5622 also affects the match. With an ideal transformer we obtain:

$$\text{Return Loss} = -20 \cdot \log_{10} \left| \frac{n^2 \cdot Z_{O(5622)}(j\omega)}{Z_o} \right|, \text{dB}$$

where

- $Z_{O(5622)}(j\omega)$ is the output impedance of the CLC5622
 - $|Z_{O(5622)}(j\omega)| \ll R_m$
- (6)

The load voltage and current will fall in the ranges:

$$|V_o| \leq n \cdot V_{max}$$

$$|I_o| \leq \frac{I_{max}}{n} \quad (7)$$

The CLC5622's high output drive current and low distortion make it a good choice for the application.

Full Duplex Cable Driver

The circuit shown in Figure 50 below, operates as a full duplex cable driver which allows simultaneous transmission and reception of signals on one transmission line. The circuit on either side of the transmission line uses are CLC5622 as a cable drive, and the second CLC5622 as a receiver. V_{oA} is an attenuated version of V_{inA} , while V_{oB} is an attenuated version of V_{inB} .

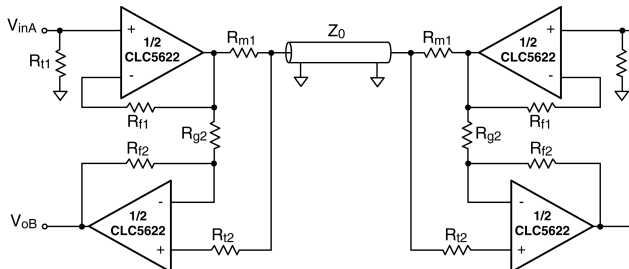

Figure 50. Full Duplex Cable Driver

R_{m1} is used to match the transmission line. R_{f2} and R_{g2} set the DC gain of the CLC5622, which is used in a difference mode. R_{f2} provides good CMRR and DC offset. The transmitting CLC5622's are shown in a unity gain configuration because they consume the least power of any gain, for a given load. for proper operation we need $R_{f2} = R_{g2}$.

The receiver output voltages are:

$$V_{outA(B)} \approx V_{inA(B)} \cdot A + \frac{V_{inB(A)}}{2} \cdot \left(1 - \frac{R_{f2}}{R_{g2}} + \frac{Z_{o(5622)}(j\omega)}{R_{m1}} \right)$$

where

- A is the attenuation of the cable
- $Z_{o(5622)}(j\omega)$ is the output impedance of the CLC5622
- $|Z_{o(5622)}(j\omega)| \ll R_{m1}$

(8)

(see the *Closed-Loop Output Resistance* plot)

We selected the component values as follows:

- $R_{f1} = 1.2k\Omega$, the recommended value for CLC5622 at unity gain.
- $R_{m1} = Z_0 = 50\Omega$, the characteristic impedance of the transmission line.
- $R_{f2} = R_{g2} = 750\Omega \geq R_{m1}$, the recommended value for the CLC5622 at $A_V = 2$
- $R_{t2} = (R_{f2} || R_{g2}) - R_{m1}/2 = 25\Omega$

These values give excellent isolation from the other input:

$$\frac{V_{oA(B)}}{V_{inB(A)}} \approx -38dB, f = 5.0MHz$$

The CLC5622 provides large output current drive, while consuming little supply current, at the nominal bias point. It also produces low distortion with large signal swings and heavy loads. These features make the CLC5622 an excellent choice for driving transmission lines.

REVISION HISTORY

Changes from Revision C (April 2013) to Revision D	Page
• Changed layout of National Data Sheet to TI format	21

IMPORTANT NOTICE

Texas Instruments Incorporated and its subsidiaries (TI) reserve the right to make corrections, enhancements, improvements and other changes to its semiconductor products and services per JESD46, latest issue, and to discontinue any product or service per JESD48, latest issue. Buyers should obtain the latest relevant information before placing orders and should verify that such information is current and complete. All semiconductor products (also referred to herein as "components") are sold subject to TI's terms and conditions of sale supplied at the time of order acknowledgment.

TI warrants performance of its components to the specifications applicable at the time of sale, in accordance with the warranty in TI's terms and conditions of sale of semiconductor products. Testing and other quality control techniques are used to the extent TI deems necessary to support this warranty. Except where mandated by applicable law, testing of all parameters of each component is not necessarily performed.

TI assumes no liability for applications assistance or the design of Buyers' products. Buyers are responsible for their products and applications using TI components. To minimize the risks associated with Buyers' products and applications, Buyers should provide adequate design and operating safeguards.

TI does not warrant or represent that any license, either express or implied, is granted under any patent right, copyright, mask work right, or other intellectual property right relating to any combination, machine, or process in which TI components or services are used. Information published by TI regarding third-party products or services does not constitute a license to use such products or services or a warranty or endorsement thereof. Use of such information may require a license from a third party under the patents or other intellectual property of the third party, or a license from TI under the patents or other intellectual property of TI.

Reproduction of significant portions of TI information in TI data books or data sheets is permissible only if reproduction is without alteration and is accompanied by all associated warranties, conditions, limitations, and notices. TI is not responsible or liable for such altered documentation. Information of third parties may be subject to additional restrictions.

Resale of TI components or services with statements different from or beyond the parameters stated by TI for that component or service voids all express and any implied warranties for the associated TI component or service and is an unfair and deceptive business practice. TI is not responsible or liable for any such statements.

Buyer acknowledges and agrees that it is solely responsible for compliance with all legal, regulatory and safety-related requirements concerning its products, and any use of TI components in its applications, notwithstanding any applications-related information or support that may be provided by TI. Buyer represents and agrees that it has all the necessary expertise to create and implement safeguards which anticipate dangerous consequences of failures, monitor failures and their consequences, lessen the likelihood of failures that might cause harm and take appropriate remedial actions. Buyer will fully indemnify TI and its representatives against any damages arising out of the use of any TI components in safety-critical applications.

In some cases, TI components may be promoted specifically to facilitate safety-related applications. With such components, TI's goal is to help enable customers to design and create their own end-product solutions that meet applicable functional safety standards and requirements. Nonetheless, such components are subject to these terms.

No TI components are authorized for use in FDA Class III (or similar life-critical medical equipment) unless authorized officers of the parties have executed a special agreement specifically governing such use.

Only those TI components which TI has specifically designated as military grade or "enhanced plastic" are designed and intended for use in military/aerospace applications or environments. Buyer acknowledges and agrees that any military or aerospace use of TI components which have **not** been so designated is solely at the Buyer's risk, and that Buyer is solely responsible for compliance with all legal and regulatory requirements in connection with such use.

TI has specifically designated certain components as meeting ISO/TS16949 requirements, mainly for automotive use. In any case of use of non-designated products, TI will not be responsible for any failure to meet ISO/TS16949.

Products

Audio	www.ti.com/audio
Amplifiers	amplifier.ti.com
Data Converters	dataconverter.ti.com
DLP® Products	www.dlp.com
DSP	dsp.ti.com
Clocks and Timers	www.ti.com/clocks
Interface	interface.ti.com
Logic	logic.ti.com
Power Mgmt	power.ti.com
Microcontrollers	microcontroller.ti.com
RFID	www.ti-rfid.com
OMAP Applications Processors	www.ti.com/omap
Wireless Connectivity	www.ti.com/wirelessconnectivity

Applications

Automotive and Transportation	www.ti.com/automotive
Communications and Telecom	www.ti.com/communications
Computers and Peripherals	www.ti.com/computers
Consumer Electronics	www.ti.com/consumer-apps
Energy and Lighting	www.ti.com/energy
Industrial	www.ti.com/industrial
Medical	www.ti.com/medical
Security	www.ti.com/security
Space, Avionics and Defense	www.ti.com/space-avionics-defense
Video and Imaging	www.ti.com/video

TI E2E Community

e2e.ti.com