

LMS75LBC176 Differential Bus Transceivers

Check for Samples: [LMS75LBC176](#)

FEATURES

- Bidirectional Transceiver
- Meet ANSI Standard RS-485
- Low Skew, 6ns
- Low Supply Current, 8mA (max)
- Wide Input and Output Voltage Range
- High Output Drive Capacity $\pm 60\text{mA}$
- Thermal Shutdown Protection
- Open Circuit Fail-Safe for Receiver
- Receiver Input Sensitivity $\pm 200\text{mV}$
- Receiver Input Hysteresis 10mV (min.)
- Single Supply Voltage Operation, 5V
- Glitch Free Power-Up and Power-Down Operation
- Pin and Functional Compatible with TI's SN75LBC176
- 8-Pin SOIC

APPLICATIONS

- Network Hubs, Bridges, and Routers
- Point of Sales Equipment (ATM, Barcode Readers,...)
- Industrial Programmable Logic Controllers
- High Speed Parallel and Serial Applications
- Multipoint Applications with Noisy Environment

DESCRIPTION

The LMS75LBC176 is a differential bus/line transceiver designed for bidirectional data communication on multipoint bus transmission lines. It is designed for balanced transmission lines. It meets TIA/EIA RS485 and ISO 8482:1987(E). The LMS75LBC176 combines a Tri-State differential line driver and differential input receiver, both of which operate from a single 5.0V power supply. The driver and receiver have an active high and active low enable, respectively, that can be externally connected to function as a direction control. The driver and receiver differential inputs are internally connected to form differential input/output (I/O) bus ports that are designed to offer minimum loading to bus whenever the driver is disabled or when $V_{CC} = 0\text{V}$. These ports feature wide positive and negative common mode voltage ranges, making the device suitable for multipoint applications in noisy environments. The LMS75LBC176 is available in a 8-Pin SOIC package. It is a drop-in socket replacement to TI's SN75LBC176.



Please be aware that an important notice concerning availability, standard warranty, and use in critical applications of Texas Instruments semiconductor products and disclaimers thereto appears at the end of this data sheet.

All trademarks are the property of their respective owners.

Typical Application

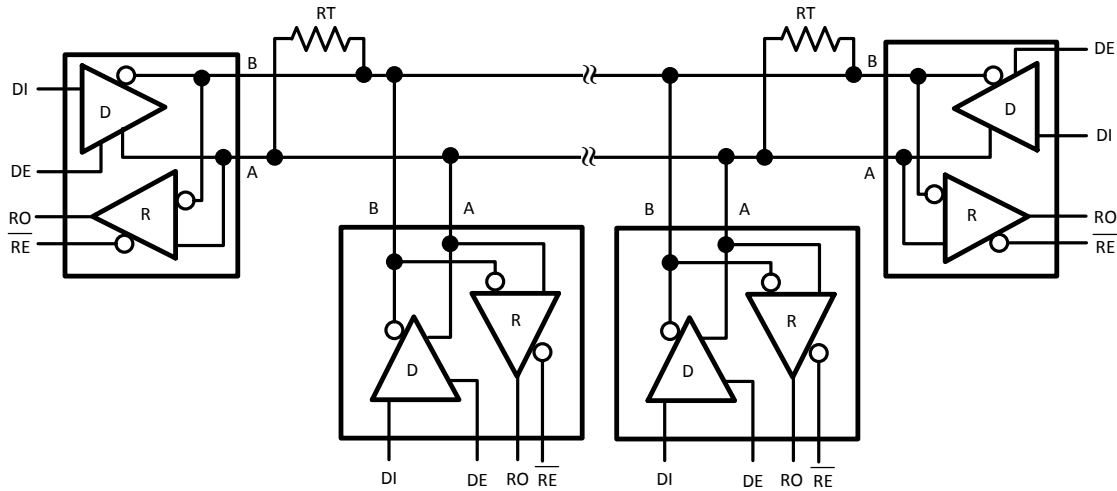

A typical multipoint application is shown in the above figure. Terminating resistors, R_T , are typically required but only located at the two ends of the cable. Pull up and pull down resistors maybe required at the end of the bus to provide failsafe biasing. The biasing resistors provide a bias to the cable when all drivers are in Tri-State, See Application Note, AN-847(SNLA031) for further information.

Connection Diagram

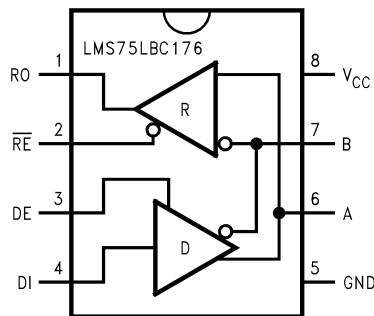

Figure 1. 8-Pin SOIC (Top View)

TRUTH TABLE ⁽¹⁾

DRIVER SECTION				
\overline{RE}	DE	DI	A	B
X	H	H	H	L
X	H	L	L	H
X	L	X	Z	Z
RECEIVER SECTION				
\overline{RE}	DE	A-B		RO
L	L	$\geq +0.2V$		H
L	L	$\leq -0.2V$		L
H	X	X		Z
L	L	OPEN *		H

- (1) * = Non Terminated, Open Input only
 X = Irrelevant
 Z = Tri-State
 H = High level
 L = Low level



These devices have limited built-in ESD protection. The leads should be shorted together or the device placed in conductive foam during storage or handling to prevent electrostatic damage to the MOS gates.

ABSOLUTE MAXIMUM RATINGS ⁽¹⁾⁽²⁾

Supply Voltage, V_{CC} ⁽³⁾	7V
Voltage Range at Any Bus Terminal	-7V to 12V
Input Voltage, V_{IN} (DI, DE, or \overline{RE})	-0.3V to $V_{CC} + 0.3V$
Package Thermal Impedance, θ_{JA}	125C/W
Junction Temperature ⁽⁴⁾	150°C
Operating Free-Air Temperature Range, T_A	0°C to 70°C
Storage Temperature Range	-65°C to 150°C
Soldering Information	Infrared or Convection (20 sec.)
ESD Rating ⁽⁵⁾	2KV

- (1) Absolute Maximum Ratings indicate limits beyond which damage to the device may occur. Operating Ratings indicate conditions for which the device is intended to be functional, but specific performance is not ensured. For ensured specifications and the test conditions, see the [ELECTRICAL CHARACTERISTICS](#) section.
- (2) If Military/Aerospace specified devices are required, please contact the Texas Instruments Sales Office/Distributors for availability and specifications.
- (3) All voltage values, except differential I/O bus voltage, are with respect to network ground terminal.
- (4) The maximum power dissipation is a function of $T_{J(MAX)}$, θ_{JA} , and T_A . The maximum allowable power dissipation at any ambient temperature is $P_D = (T_{J(MAX)} - T_A)/\theta_{JA}$. All numbers apply for packages soldered directly into a PC board.
- (5) ESD rating based upon human body model, 100pF discharged through 1.5k Ω .

OPERATING RATINGS

	Min	Nom	Max	
Supply Voltage, V_{CC}	4.75	5.0	5.25	V
Voltage at any Bus Terminal (Separately or Common Mode)			12	V
V_{IN} or V_{IC}			-7	
High-Level Input Voltage, V_{IH} ⁽¹⁾	2			V
Low-Level Input Voltage, V_{IL} ⁽¹⁾			0.8	V
Differential Input Voltage, V_{ID} ⁽²⁾			± 12	V
High-Level Output	Driver, I_{OH}		-60	mA
	Receiver, I_{OH}		-400	μA
Low-Level Output	Driver, I_{OL}		60	mA
	Receiver, I_{OL}		8	mA

- (1) Voltage limits apply to DI, DE, \overline{RE} pins.
- (2) Differential input/output bus voltage is measured at the non-inverting terminal A with respect to the inverting terminal B

ELECTRICAL CHARACTERISTICS

 $V_{CC} = 5V, T_A = 0^{\circ}C \text{ to } 70^{\circ}C$

Symbol	Parameter	Conditions	Min	Typ	Max	Units
Driver Section						
V_{CL}	Input Clamp Voltage	$I_I = -18mA$			-1.5	V
V_O	Output Voltage	$I_O = 0$	0		6	V
$ V_{OD1} $	Differential Output Voltage	$I_O = 0$	1.5		6	V
$ V_{OD2} $	Differential Output Voltage	$R_L = 54\Omega$	1.5		5	V
V_{OD3}	Differential Output Voltage	$V_{TEST} = -7V \text{ to } 12V$	1.5		5	V
ΔV_{OD}	Change in Magnitude of Differential Output Voltage ⁽¹⁾	$R_L = 54\Omega \text{ or } 100\Omega$			± 0.2	V
V_{OC}	Common-Mode Output Voltage	$R_L = 54\Omega \text{ or } 100\Omega$			3 -1	V
ΔV_{OC}	Change in Magnitude of Differential Output Voltage ⁽¹⁾	$R_L = 54\Omega \text{ or } 100\Omega$			± 0.2	V
I_O	Output Current	Output Disabled ⁽¹⁾			1 -0.8	mA
		$V_O = 12V$				
		$V_O = -7V$				
I_{IH}	High-Level Input Current	$V_{IN} = 2.4V$			-100	μA
I_{IL}	Low-Level Input Current	$V_{IN} = 0.4V$			-100	μA
I_{OSD}	Short-Circuit Output Current	$V_O = -7V$			-250	mA
		$V_O = 0$			-150	
		$V_O = V_{CC}$			250	
		$V_O = 12V$			250	
I_{CC}	Supply Current	$V_{IN} = 0 \text{ or } V_{CC}$, No Load			8	mA
		Receiver Disabled and Driver Enabled				
		Receiver and Driver Disabled			8	
Switching Characteristics						
t_d (OD)	Differential Output Delay Time	$R_L = 54\Omega, C_L = 50pF$	3		25	ns
t_t (OD)	Differential Output Transition Time	$R_L = 54\Omega, C_L = 50pF$		8		ns
$t_{sk(p)}$	Pulse Skew, ($t_{d(ODH)} - t_{d(ODL)}$)	$R_L = 54\Omega, C_L = 50pF$		0	6	ns
t_{PZH}	Output Enable Time to High Level	$R_L = 110\Omega, C_L = 50pF$			35	ns
t_{PZL}	Output Enable Time to Low Level	$R_L = 110\Omega, C_L = 50pF$			35	ns
t_{PHZ}	Output Disable Time from High Level	$R_L = 110\Omega, C_L = 50pF$			60	ns
t_{PLZ}	Output Disable Time from Low Level	$R_L = 110\Omega, C_L = 50pF$			35	ns

(1) Applies to both power on and off (ANSI Standard RS-485 conditions).

ELECTRICAL CHARACTERISTICS (continued)

 $V_{CC} = 5V, T_A = 0^{\circ}C \text{ to } 70^{\circ}C$

Symbol	Parameter	Conditions	Min	Typ	Max	Units
Receiver Section						
V_{TH+}	Positive-Going Input Threshold Voltage	$V_O = 2.7V, I_O = -0.4mA$			0.2	V
V_{TH-}	Negative-Going Input Threshold Voltage	$V_O = 0.5V, I_O = 8mA$	-0.2			V
ΔV_{TH}	Hysteresis Voltage ($V_{TH+} - V_{TH-}$)		10			mV
V_{CL}	Enable-Input Clamp Voltage	$I_I = -18mA$			-1.5	V
V_{OH}	High-Level Output Voltage	$V_{ID} = 200mV, I_{OH} = -400\mu A$	2.7			V
V_{OL}	Low-Level Output Voltage	$V_{ID} = -200mV, I_{OL} = 8mA$			0.45	V
I_{OZ}	High-Impedance-State Output Current	$V_O = 0.4V \text{ to } 2.4V$			± 20	μA
I_{IN}	Line Input Current	Other Input = 0V, See ⁽²⁾	$V_{IN} = 12V$		1	mA
			$V_{IN} = -7V$		-0.8	
I_{IH}	High-Level Enable-Input Current	$V_{IH} = 2.7V$			-100	μA
I_{IL}	Low-Level Enable-Input Current	$V_{IL} = 0.4V$			-100	μA
R_{IN}	Input Resistance		12			k Ω
I_{CC}	Supply Current	$V_{IN} = 0 \text{ or } V_{CC},$ No Load	Receiver Enabled and Driver Disabled		8	mA
			Receiver and Driver Disabled		8	
Switching Characteristics						
T_{PLH}	Propagation Delay Time, Low-to High-Level Single-Ended Output	$V_{ID} = -1.5V \text{ to } 1.5V$	8		33	ns
T_{PHL}	Propagation Delay Time, High-to Low-Level Single-Ended Output	$V_{ID} = -1.5V \text{ to } 1.5V$	8		33	ns
$t_{sk(p)}$	Pulse Skew ($ t_{PLH} - t_{PHL} $)	$V_{ID} = -1.5V \text{ to } 1.5V$		2		ns
t_{PZH}	Output Enable Time to High Level				35	ns
t_{PZL}	Output Enable Time to Low Level				30	ns
t_{PHZ}	Output Disable Time from High Level				35	ns
t_{PLZ}	Output Disable Time from Low Level				30	ns

(2) Applies to both power on and off (ANSI Standard RS-485 conditions).

PARAMETER MEASURING INFORMATION

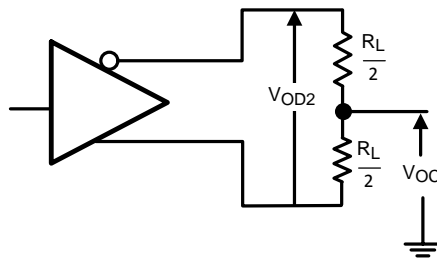

Figure 2. Test Circuit for V_{OD2} and V_{OC}

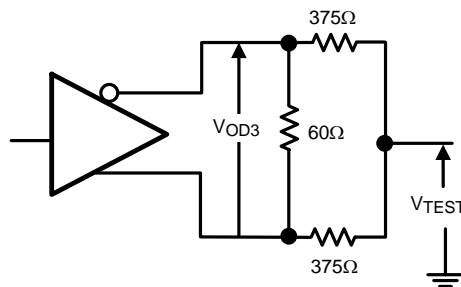

Figure 3. Test Circuit for V_{OD2}

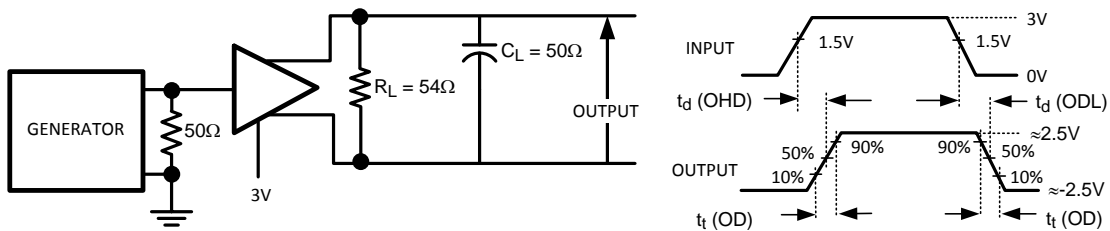

Figure 4. Test Circuit for Driver Differential Output Delay and Transition Times

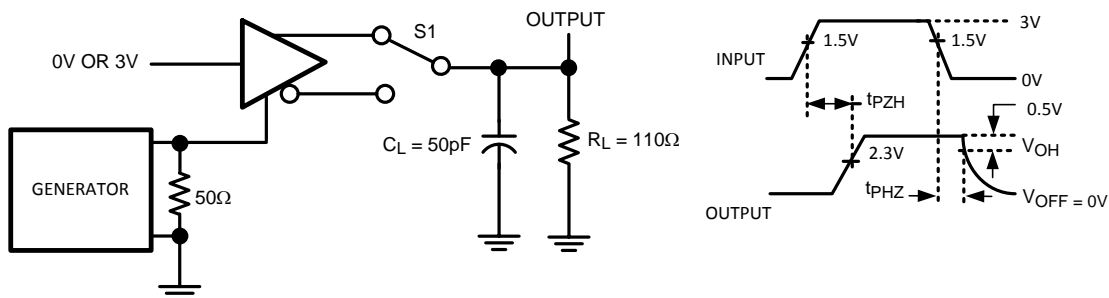

Figure 5. Test Circuit for Driver T_{PZH} and T_{PHZ}

PARAMETER MEASURING INFORMATION (continued)

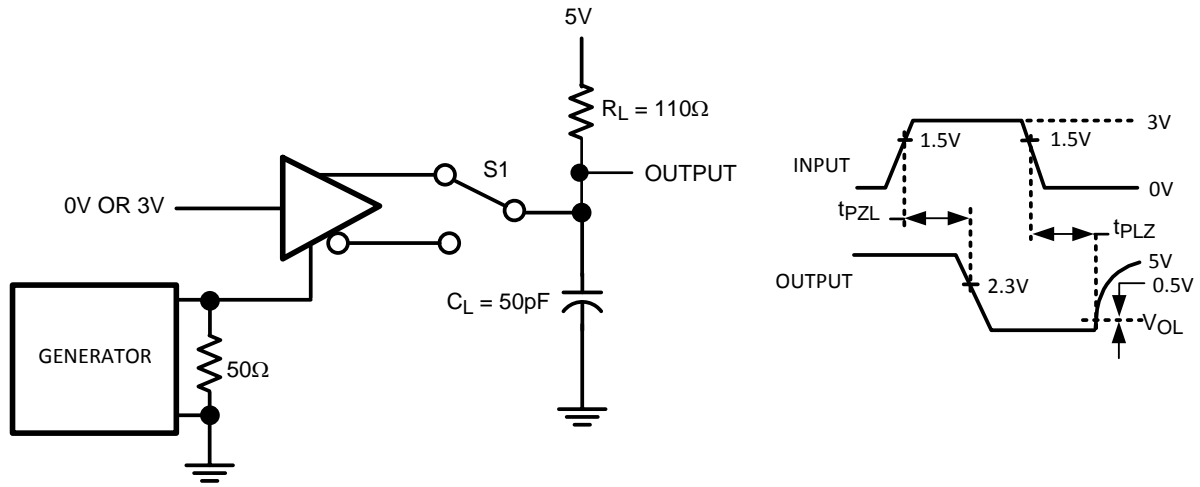

Figure 6. Test Circuit for Driver T_{PZL} and T_{PLZ}

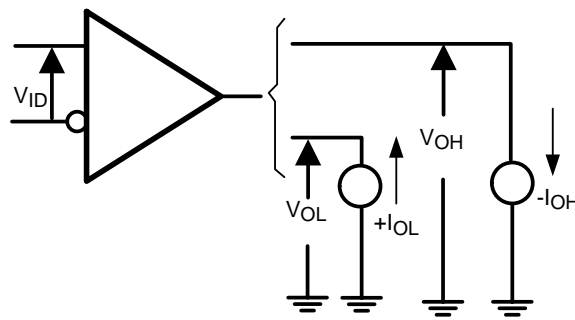

Figure 7. Test Circuit for Receiver V_{OH} and V_{OL}

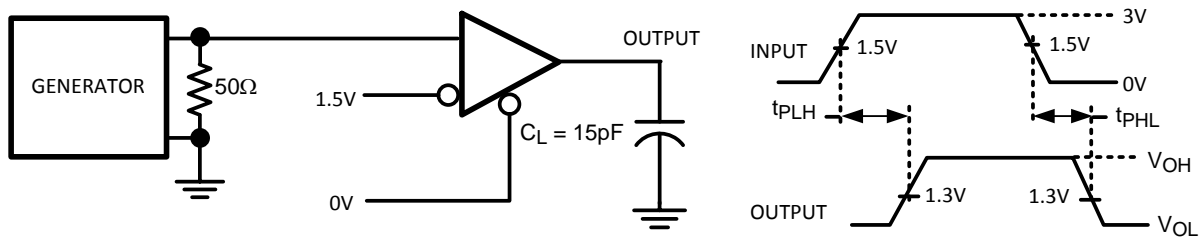

Figure 8. Test Circuit for Receiver T_{PLH} and T_{PHL}

PARAMETER MEASURING INFORMATION (continued)

Test Circuit

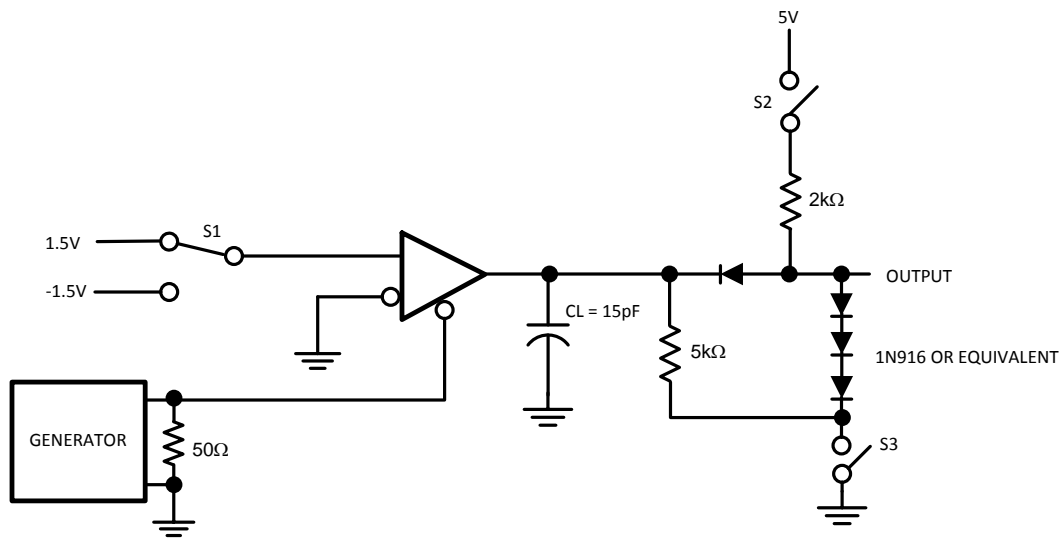
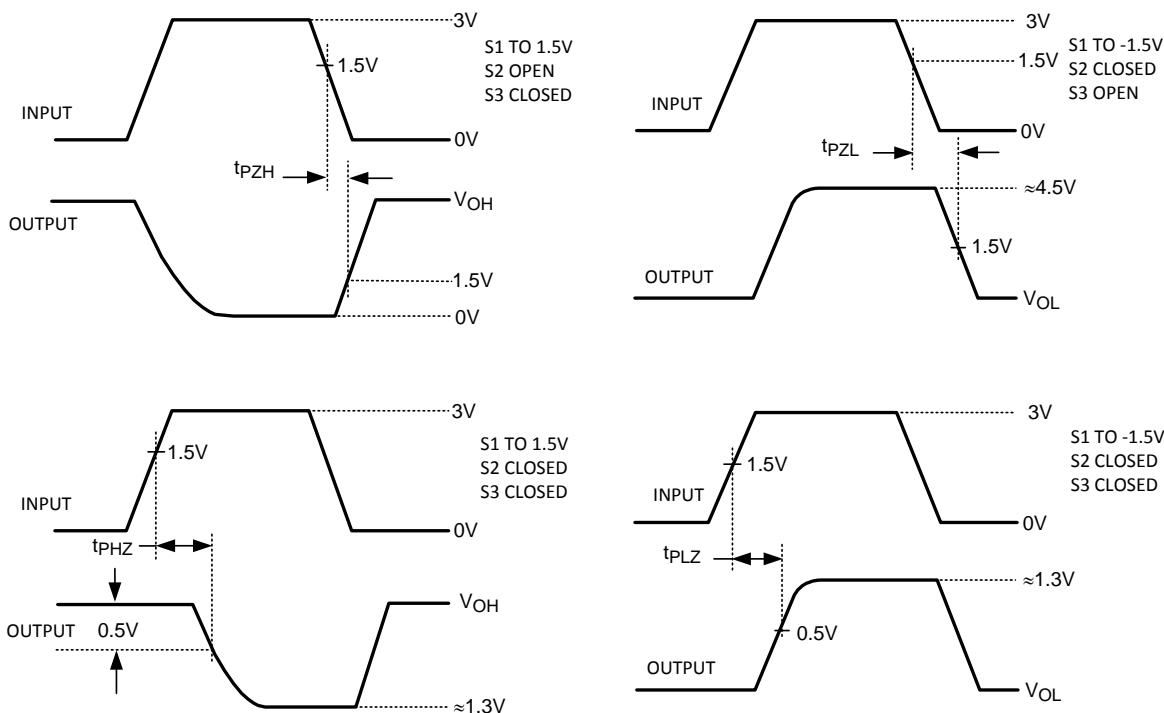

Figure 9. Test Circuit for Receiver T_{PZH}/T_{PZL} and T_{PHZ}/T_{PLZ}

Voltage Waveforms



VOLTAGE WAVEFORMS

Figure 10. Test Circuit for Receiver T_{PZH}/T_{PZL} and T_{PHZ}/T_{PLZ}

APPLICATION INFORMATION

Power Line Noise Filtering

A factor to consider in designing power and ground is noise filtering. A noise filtering circuit is designed to prevent noise generated by the integrated circuit (IC) as well as noise entering the IC from other devices. A common filtering method is to place by-pass capacitors (C_{bp}) between the power and ground lines.

Placing a by-pass capacitor (C_{bp}) with the correct value at the proper location solves many power supply noise problems. Choosing the correct capacitor value is based upon the desired noise filtering range. Since capacitors are not ideal, they may act more like inductors or resistors over a specific frequency range. Thus, many times two by-pass capacitors may be used to filter a wider bandwidth of noise. It is highly recommended to place a larger capacitor, such as $10\mu\text{F}$, between power supply pin and ground to filter out low frequencies and a $0.1\mu\text{F}$ to filter out higher frequencies.

By-pass capacitors must be mounted as close as possible to the IC to be effective. Long leads produce higher impedance at higher frequencies due to stray inductance. Thus, this will reduce the by-pass capacitor's effectiveness. Surface mounting chip capacitors are the best solution because they have lower inductance.

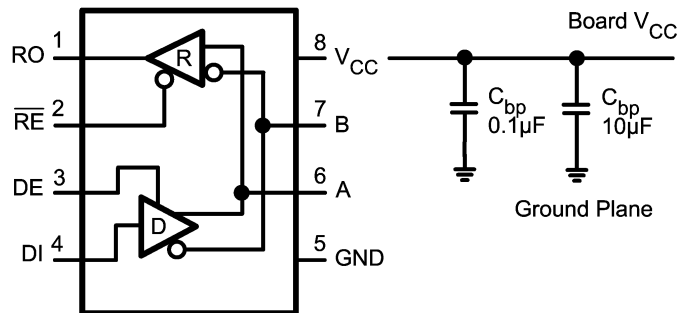

Figure 11. Placement of by-pass Capacitors, C_{bp}

REVISION HISTORY

Changes from Revision B (April 2013) to Revision C	Page
• Changed layout of National Data Sheet to TI format	9

IMPORTANT NOTICE

Texas Instruments Incorporated and its subsidiaries (TI) reserve the right to make corrections, enhancements, improvements and other changes to its semiconductor products and services per JESD46, latest issue, and to discontinue any product or service per JESD48, latest issue. Buyers should obtain the latest relevant information before placing orders and should verify that such information is current and complete. All semiconductor products (also referred to herein as "components") are sold subject to TI's terms and conditions of sale supplied at the time of order acknowledgment.

TI warrants performance of its components to the specifications applicable at the time of sale, in accordance with the warranty in TI's terms and conditions of sale of semiconductor products. Testing and other quality control techniques are used to the extent TI deems necessary to support this warranty. Except where mandated by applicable law, testing of all parameters of each component is not necessarily performed.

TI assumes no liability for applications assistance or the design of Buyers' products. Buyers are responsible for their products and applications using TI components. To minimize the risks associated with Buyers' products and applications, Buyers should provide adequate design and operating safeguards.

TI does not warrant or represent that any license, either express or implied, is granted under any patent right, copyright, mask work right, or other intellectual property right relating to any combination, machine, or process in which TI components or services are used. Information published by TI regarding third-party products or services does not constitute a license to use such products or services or a warranty or endorsement thereof. Use of such information may require a license from a third party under the patents or other intellectual property of the third party, or a license from TI under the patents or other intellectual property of TI.

Reproduction of significant portions of TI information in TI data books or data sheets is permissible only if reproduction is without alteration and is accompanied by all associated warranties, conditions, limitations, and notices. TI is not responsible or liable for such altered documentation. Information of third parties may be subject to additional restrictions.

Resale of TI components or services with statements different from or beyond the parameters stated by TI for that component or service voids all express and any implied warranties for the associated TI component or service and is an unfair and deceptive business practice. TI is not responsible or liable for any such statements.

Buyer acknowledges and agrees that it is solely responsible for compliance with all legal, regulatory and safety-related requirements concerning its products, and any use of TI components in its applications, notwithstanding any applications-related information or support that may be provided by TI. Buyer represents and agrees that it has all the necessary expertise to create and implement safeguards which anticipate dangerous consequences of failures, monitor failures and their consequences, lessen the likelihood of failures that might cause harm and take appropriate remedial actions. Buyer will fully indemnify TI and its representatives against any damages arising out of the use of any TI components in safety-critical applications.

In some cases, TI components may be promoted specifically to facilitate safety-related applications. With such components, TI's goal is to help enable customers to design and create their own end-product solutions that meet applicable functional safety standards and requirements. Nonetheless, such components are subject to these terms.

No TI components are authorized for use in FDA Class III (or similar life-critical medical equipment) unless authorized officers of the parties have executed a special agreement specifically governing such use.

Only those TI components which TI has specifically designated as military grade or "enhanced plastic" are designed and intended for use in military/aerospace applications or environments. Buyer acknowledges and agrees that any military or aerospace use of TI components which have **not** been so designated is solely at the Buyer's risk, and that Buyer is solely responsible for compliance with all legal and regulatory requirements in connection with such use.

TI has specifically designated certain components as meeting ISO/TS16949 requirements, mainly for automotive use. In any case of use of non-designated products, TI will not be responsible for any failure to meet ISO/TS16949.

Products

Audio	www.ti.com/audio
Amplifiers	amplifier.ti.com
Data Converters	dataconverter.ti.com
DLP® Products	www.dlp.com
DSP	dsp.ti.com
Clocks and Timers	www.ti.com/clocks
Interface	interface.ti.com
Logic	logic.ti.com
Power Mgmt	power.ti.com
Microcontrollers	microcontroller.ti.com
RFID	www.ti-rfid.com
OMAP Applications Processors	www.ti.com/omap
Wireless Connectivity	www.ti.com/wirelessconnectivity

Applications

Automotive and Transportation	www.ti.com/automotive
Communications and Telecom	www.ti.com/communications
Computers and Peripherals	www.ti.com/computers
Consumer Electronics	www.ti.com/consumer-apps
Energy and Lighting	www.ti.com/energy
Industrial	www.ti.com/industrial
Medical	www.ti.com/medical
Security	www.ti.com/security
Space, Avionics and Defense	www.ti.com/space-avionics-defense
Video and Imaging	www.ti.com/video

TI E2E Community

e2e.ti.com