

## LMS1487E Low Power RS-485 / RS-422 Differential Bus Transceiver

Check for Samples: [LMS1487E](#)

### FEATURES

- Meet ANSI Standard RS-485 and RS-422
- Data Rate 2.5 Mbps
- Single Supply Voltage Operation, 5V
- Wide Input and Output Voltage Range
- Thermal Shutdown Protection
- Short Circuit Protection
- Low Quiescent Current 660 $\mu$ A (max)
- Allows Up To 128 Transceivers on the Bus
- Open Circuit Fail-Safe for Receiver
- Extended Operating Temperature Range  $-40^{\circ}\text{C}$  to  $85^{\circ}\text{C}$
- Drop-In Replacement to MAX1487E
- Available in 8-pin SOIC and 8-pin PDIP Packages

### APPLICATIONS

- Low Power RS-485 Systems
- Network Hubs, Bridges, and Routers
- Point of Sales Equipment (ATM, Barcode Scanners,...)
- Local Area Networks (LAN)
- Integrated Service Digital Network (ISDN)
- Industrial Programmable Logic Controllers
- High Speed Parallel and Serial Applications
- Multipoint Applications With Noisy Environment

### DESCRIPTION

The LMS1487E is a low power differential bus/line transceiver designed for high speed bidirectional data communication on multipoint bus transmission lines. It is designed for balanced transmission lines. It meets ANSI Standards TIA/EIA RS422-B, TIA/EIA RS485-A and ITU recommendation and V.11 and X.27. The driver outputs and receiver inputs have  $\pm 15\text{kV}$  ESD protection. The LMS1487E combines a TRI-STATE differential line driver and differential input receiver, both of which operate from a single 5.0V power supply. The driver and receiver have an active high and active low, respectively, that can be externally connected to function as a direction control. The driver outputs and receiver inputs are internally connected to form a differential input/output (I/O) bus port that is designed to offer minimum loading to bus whenever the driver is disabled or when  $V_{CC} = 0\text{V}$ . These ports feature wide positive and negative common mode voltage ranges, making the device suitable for multipoint applications in noisy environments. The LMS1487E is available in 8-Pin SOIC and 8-pin PDIP packages. It is a drop-in replacement to Maxim's MAX1487E.



Please be aware that an important notice concerning availability, standard warranty, and use in critical applications of Texas Instruments semiconductor products and disclaimers thereto appears at the end of this data sheet.

All trademarks are the property of their respective owners.

## TYPICAL APPLICATION

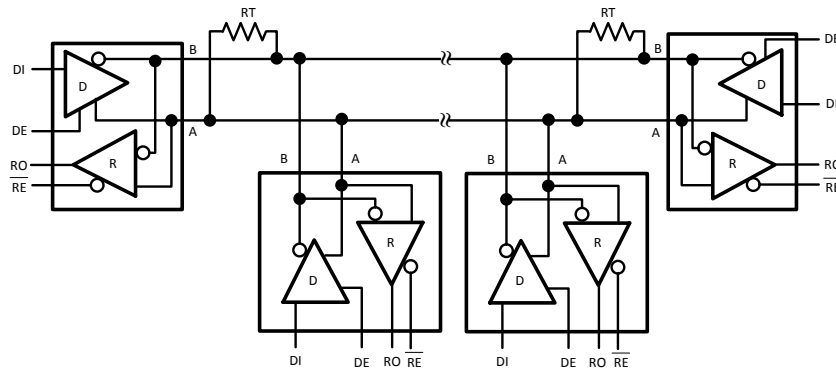

A typical multipoint application is shown in the above figure. Terminating resistor,  $R_T$  are typically required but only located at the two ends of the cable. Pull-up and pull-down resistors maybe required at the end of the bus to provide fail-safe biasing. The biasing resistors provide a bias to the cable when all drivers are in TRI-STATE, See Texas Instruments Application Note, [AN-847](#) for further information.

## CONNECTION DIAGRAM

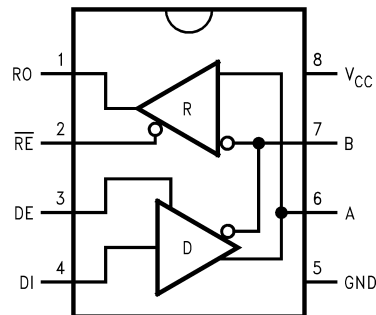

**Figure 1. 8-Pin SOIC / PDIP (Top View)**

**TRUTH TABLE<sup>(1)</sup>**

DRIVER SECTION				
$\overline{RE}^*$	DE	DI	A	B
X	H	H	H	L
X	H	L	L	H
X	L	X	Z	Z
RECEIVER SECTION				
$\overline{RE}^*$	DE	A-B		RO
L	L	$\geq +0.2V$		H
L	L	$\leq -0.2V$		L
H	X	X		Z
L	L	OPEN *		H

- (1) \* = Non Terminated, Open Input only  
 X = Irrelevant  
 Z = TRI-STATE  
 H = High level  
 L = Low level

**Table 1. PIN DESCRIPTIONS**

Pin #	I/O	Name	Function
1	O	RO	Receiver Output: If $A > B$ by 200 mV, RO will be high; If $A < B$ by 200 mV, RO will be low. RO will be high also if the inputs (A and B) are open (non-terminated).
2	I	$\overline{RE}^*$	Receiver Output Enable: RO is enabled when $\overline{RE}^*$ is low; RO is in TRI-STATE when $\overline{RE}^*$ is high
3	I	DE	Driver Output Enable: The driver outputs (A and B) are enabled when DE is high; they are in TRI-STATE when DE is low. Pins A and B also function as the receiver input pins (see below)
4	I	DI	Driver Input: A low on DI forces A low and B high while a high on DI forces A high and B low when the driver is enabled
5	NA	GND	Ground
6	I/O	A	Non-inverting Driver Output and Receiver Input pin. Driver output levels conform to RS-485 signaling levels
7	I/O	B	Inverting Driver Output and Receiver Input pin. Driver Output levels conform to RS-485 signaling levels
8	NA	$V_{CC}$	Power Supply: $4.75V \leq V_{CC} \leq 5.25V$



These devices have limited built-in ESD protection. The leads should be shorted together or the device placed in conductive foam during storage or handling to prevent electrostatic damage to the MOS gates.

### ABSOLUTE MAXIMUM RATINGS<sup>(1)(2)</sup>

Supply Voltage, $V_{CC}$ <sup>(3)</sup>		6V
Input Voltage, $V_{IN}$ (DI, DE, or $\overline{RE}$ )		-0.3V to $V_{CC} + 0.3V$
Voltage Range at Bus Terminals (AB)		-7V to 12V
Receiver Output		-0.3V to $V_{CC} + 0.3V$
Package Thermal Impedance, $\theta_{JA}$	SOIC	125° C/W
	PDIP	92° C/W
Junction Temperature <sup>(4)</sup>		150°C
Operating Free-Air Temperature Range, $T_A$	Commercial	0°C to 70°C
	Industrial	-40°C to 85°C
Storage Temperature Range		-65°C to 150°C
Soldering Information	Infrared or Convection (20 sec.)	235°C
	Lead Temperature Range	+260°C
ESD Rating (Human Body Model) <sup>(5)</sup>	Bus Pins	15kV
	Other Pins	2kV
ESD Rating (Machine Model)	All Pins	200V

- (1) Absolute Maximum Ratings indicate limits beyond which damage to the device may occur. Operating Ratings indicate conditions for which the device is intended to be functional, but specific performance is not ensured. For ensured specifications and the test conditions, see the [ELECTRICAL CHARACTERISTICS](#).
- (2) If Military/Aerospace specified devices are required, please contact the Texas Instruments Sales Office/Distributors for availability and specifications.
- (3) All voltage values, except differential I/O bus voltage, are with respect to the network ground terminal.
- (4) The maximum power dissipation is a function of  $T_{J(MAX)}$ ,  $\theta_{JA}$ , and  $T_A$ . The maximum allowable power dissipation at any ambient temperature,  $T_A$ , is  $P_D = (T_{J(MAX)} - T_A)/\theta_{JA}$ . All numbers apply for packages soldered directly into a PC board.
- (5) ESD rating based upon human body model, 100 pF discharged through 1.5 k $\Omega$ .

### OPERATING RATINGS

	Min	Nom	Max	
Supply Voltage, $V_{CC}$	4.75	5.0	5.25	V
Voltage at any Bus Terminal (Separately or Common Mode)	-7		12	V
High-Level Input Voltage, $V_{IH}$ <sup>(1)</sup>	2			V
Low-Level Input Voltage, $V_{IL}$ <sup>(1)</sup>			0.8	V
Differential Input Voltage, $V_{ID}$ <sup>(2)</sup>			$\pm 12$	V

- (1) Voltage limits apply to DI, DE,  $\overline{RE}$  pins.
- (2) Differential input/output bus voltage is measured at the non-inverting terminal A with respect to the inverting terminal B.

## ELECTRICAL CHARACTERISTICS

Over recommended ranges of supply voltage and operating free-air temperature (unless otherwise noted)

Symbol	Parameter	Conditions	Min	Typ	Max	Units
<b>Driver Section</b>						
$ V_{OD1} $	Differential Output Voltage	$R = \infty$ (see Figure 11)			5.25	V
$ V_{OD2} $	Differential Output Voltage	$R = 50\Omega$ (see Figure 11), RS-422	2.0			V
		$R = 27\Omega$ (see Figure 11), RS-485	1.5		5.0	
$\Delta V_{OD}$	Change in Magnitude of Driver Differential Output Voltage for Complementary Output States	$R = 27\Omega$ or $50\Omega$ (see Figure 11) <sup>(1)</sup>			0.2	V
$V_{OC}$	Common Mode Output Voltage	$R = 27\Omega$ or $50\Omega$ (see Figure 11)			3.0	V
$\Delta V_{OC}$	Change in Magnitude of Driver Common-Mode Output Voltage for Complementary Output States	$R = 27\Omega$ or $50\Omega$ (see Figure 11) <sup>(1)</sup>			0.2	V
$V_{IH}$	CMOS Input Logic Threshold High	DE, DI, $\overline{RE}$	2.0			V
$V_{IL}$	CMOS Input Logic Threshold Low	DE, DI, $\overline{RE}$			0.8	V
$I_{IN1}$	Logic Input Current	DE, DI, $\overline{RE}$			$\pm 2$	$\mu A$
<b>Receiver Section</b>						
$I_{IN2}$	Input Current (A, B)	DE = 0V, $V_{CC} = 0V$ or 5.25V $V_{IN} = 12V$			0.25	mA
		$V_{IN} = -7V$			-0.2	
$V_{TH}$	Differential Input Threshold Voltage	$-7V \leq V_{CM} \leq +12V$	-0.2		+0.2	V
$\Delta V_{TH}$	Input Hysteresis ( $V_{TH+} - V_{TH-}$ )	$V_{CM} = 0$		95		mV
$V_{OH}$	CMOS High-level Output Voltage	$I_{OH} = 4 mA$ , $V_{ID} = -200 mV$	3.5			V
$V_{OL}$	CMOS Low-level Output Voltage	$I_{OL} = -4 mA$ , $V_{ID} = 200 mV$			0.4	V
$I_{OZR}$	Tristate Output Leakage Current	$0.4V \leq V_O \leq +2.4V$			$\pm 1$	$\mu A$
$R_{IN}$	Input Resistance	$-7V \leq V_{CM} \leq +12V$	48			k $\Omega$
<b>Power Supply Current</b>						
$I_{CC}$	Supply Current	DE = $V_{CC}$ , $\overline{RE} = GND$ or $V_{CC}$		400	660	$\mu A$
		DE = 0V, $\overline{RE} = GND$ or $V_{CC}$		360	560	
$I_{OSD1}$	Driver Short-circuit Output Current	$V_O = \text{high}$ , $-7V \leq V_{CM} \leq +12V$			250	mA
$I_{OSD2}$	Driver Short-circuit Output Current	$V_O = \text{low}$ , $-7V \leq V_{CM} \leq +12V$			250	mA
$I_{OSR}$	Receiver Short-circuit Output Current	$0V \leq V_O \leq V_{CC}$			95	mA

(1)  $|\Delta V_{OD}|$  and  $|\Delta V_{OC}|$  are changes in magnitude of  $V_{OD}$  and  $V_{OC}$  respectively, when the input changes from high to low levels.

## ELECTRICAL CHARACTERISTICS (continued)

Over recommended ranges of supply voltage and operating free-air temperature (unless otherwise noted)

Symbol	Parameter	Conditions	Min	Typ	Max	Units
<b>Switching Characteristics</b>						
<b>Driver</b>						
$T_{PLH}$ , $T_{PHL}$	Propagation Delay Input to Output	$R_L = 54\Omega$ , $C_L = 100\text{ pF}$	10	40	80	ns
$T_{SKEW}$	Driver Output Skew	$R_L = 54\Omega$ , $C_L = 100\text{ pF}$		5	10	ns
$T_R$ , $T_F$	Driver Rise and Fall Time	$R_L = 54\Omega$ , $C_L = 100\text{ pF}$	3	10	40	ns
$T_{ZH}$ , $T_{ZL}$	Driver Enable to Output Valid Time	$C_L = 100\text{ pF}$		25	70	ns
$T_{HZ}$ , $T_{LZ}$	Driver Output Disable Time	$C_L = 15\text{ pF}$		35	70	ns
<b>Receiver</b>						
$T_{PLH}$ , $T_{PHL}$	Propagation Delay Input to Output	$R_L = 54\Omega$ , $C_L = 100\text{ pF}$	20	90	200	ns
$T_{SKEW}$	Receiver Output Skew	$R_L = 54\Omega$ , $C_L = 100\text{ pF}$		5		ns
$T_{ZH}$ , $T_{ZL}$	Receiver Enable Time	$C_L = 15\text{ pF}$		20	50	ns
$T_{HZ}$ , $T_{LZ}$	Receiver Disable Time	$C_L = 15\text{ pF}$		20	50	ns
$F_{MAX}$	Maximum Data Rate		2.5			Mbps

TYPICAL PERFORMANCE CHARACTERISTICS

Output Current vs. Receiver Output Low Voltage

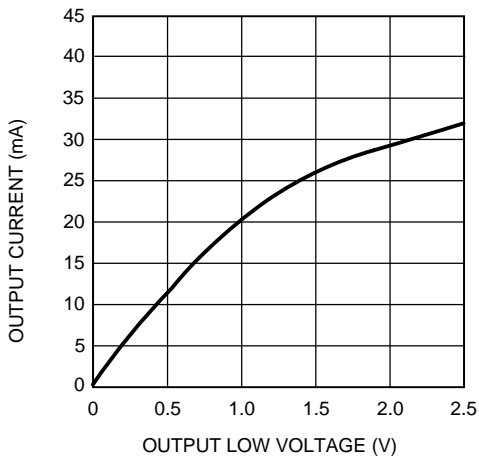

Figure 2.

Output Current vs. Receiver Output High Voltage

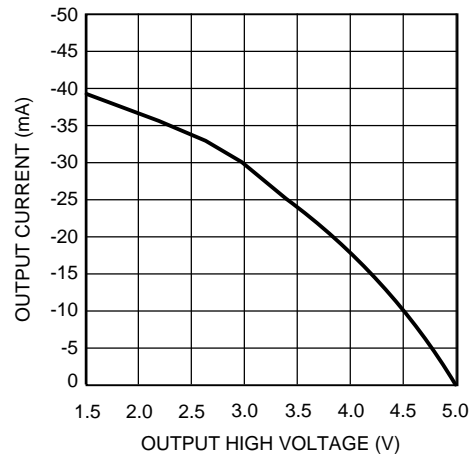

Figure 3.

Receiver Output High Voltage vs. Temperature

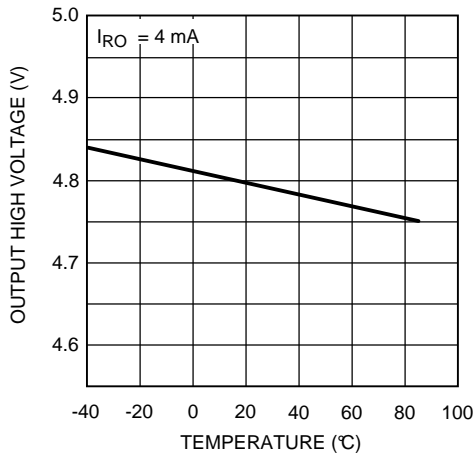

Figure 4.

Receiver Output Low-Voltage vs. Temperature

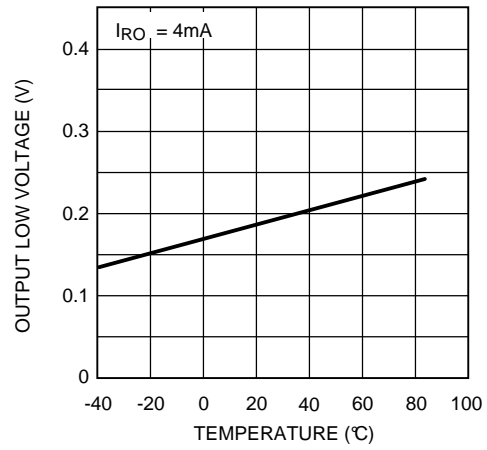

Figure 5.

Driver Output Current vs. Differential Output Voltage

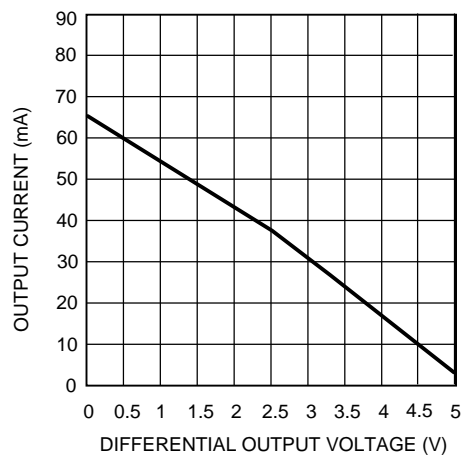

Figure 6.

Driver Differential Output Voltage vs. Temperature

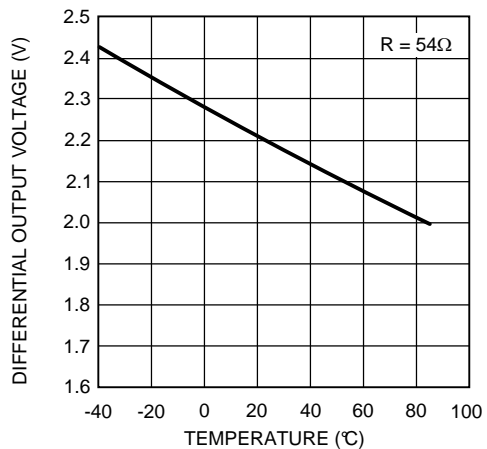

Figure 7.

### TYPICAL PERFORMANCE CHARACTERISTICS (continued)

Output Current vs. Driver Output Low Voltage

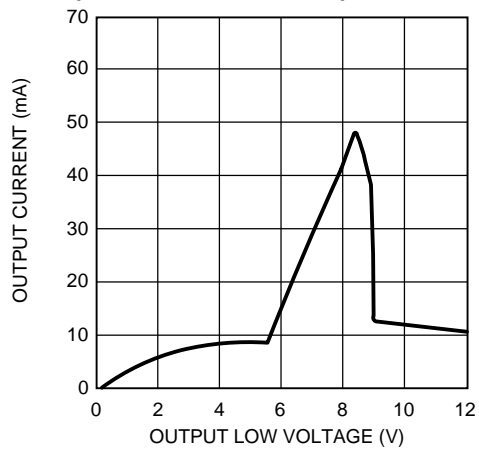

Figure 8.

Output Current vs. Driver Output High Voltage

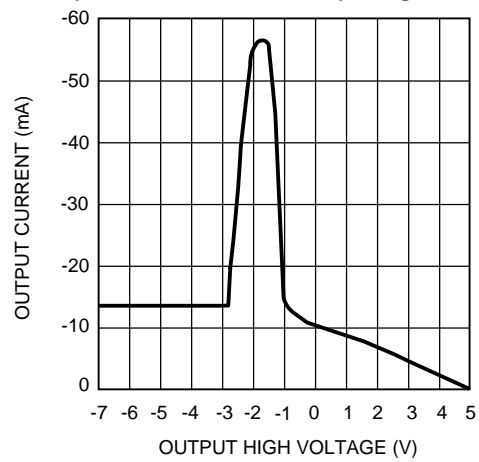

Figure 9.

Supply Current vs. Temperature

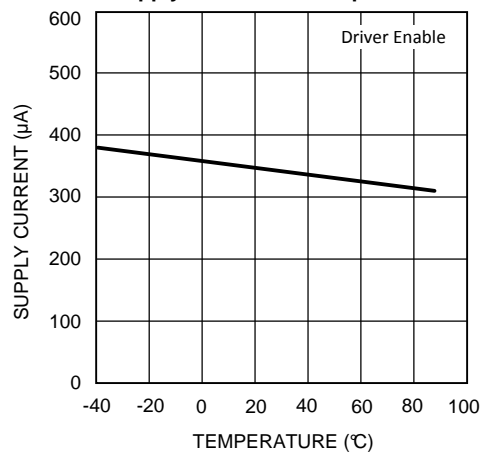

Figure 10.

PARAMETER MEASURING INFORMATION

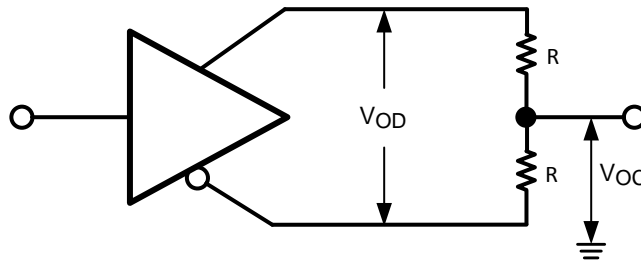

Figure 11. Test Circuit for  $V_{OD}$  and  $V_{OC}$

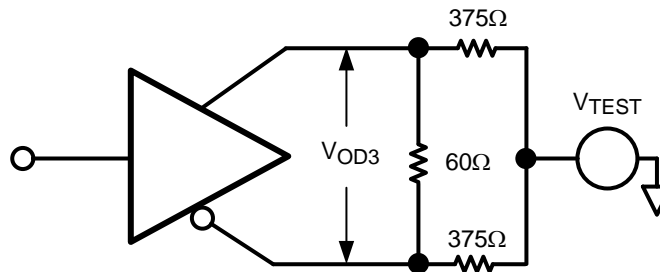

Figure 12. Test Circuit for  $V_{OD3}$

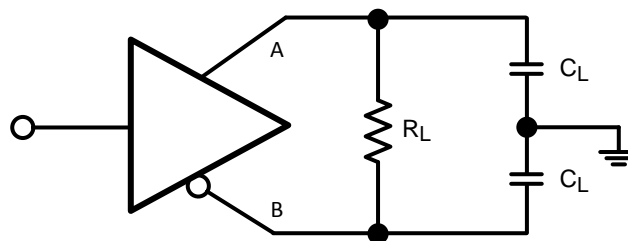

Figure 13. Test Circuit for Driver Propagation Delay

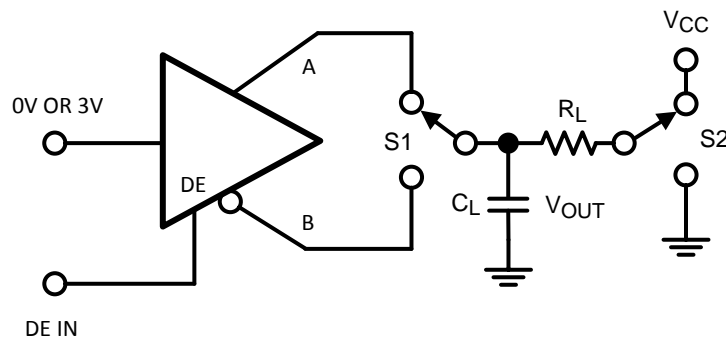

Figure 14. Test Circuit for Driver Enable / Disable



PARAMETER MEASURING INFORMATION (continued)

SWITCHING CHARACTERISTICS

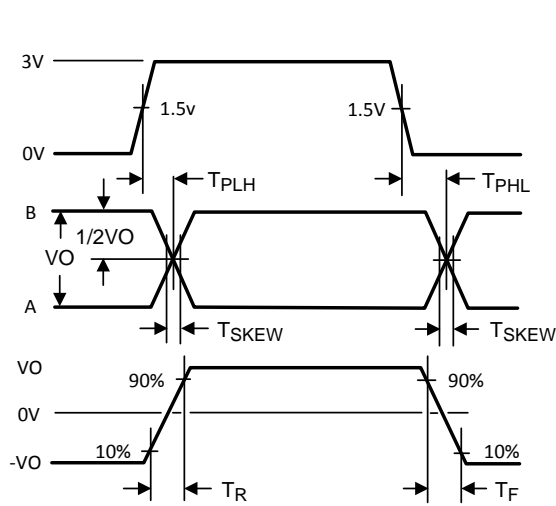

Figure 17. Driver Propagation Delay, Rise / Fall Time

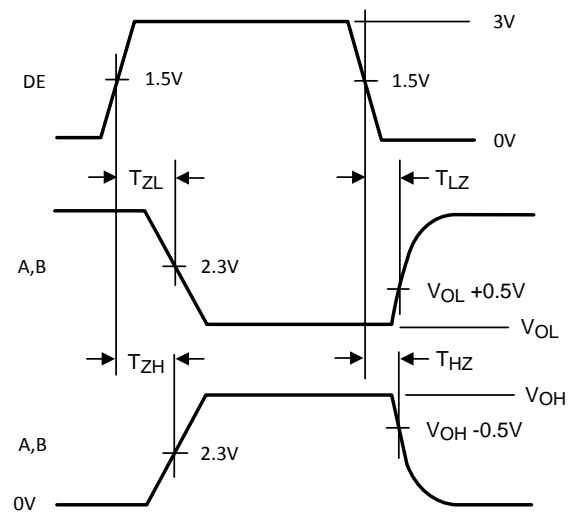

Figure 18. Driver Enable / Disable Time

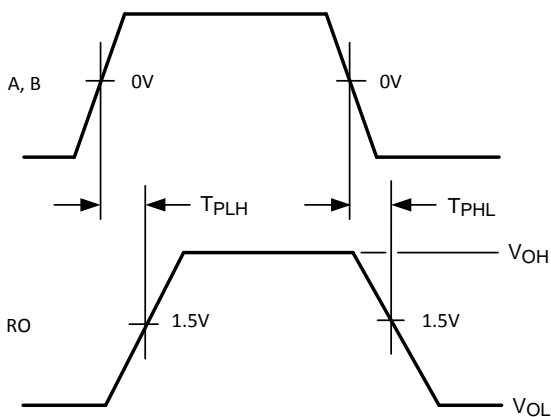

Figure 19. Receiver Propagation Delay

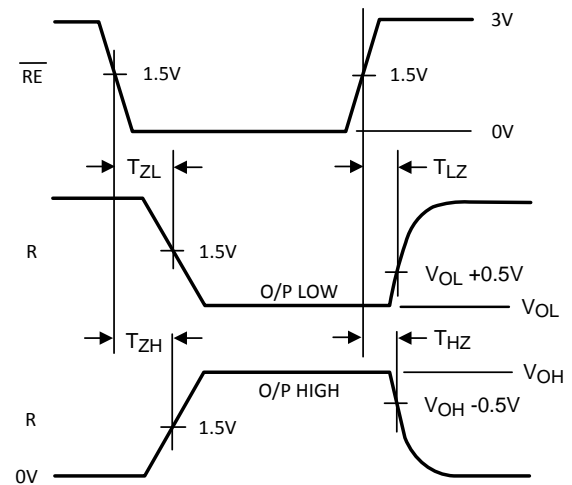

Figure 20. Receiver Enable / Disable Time

## APPLICATION INFORMATION

### POWER LINE NOISE FILTERING

A factor to consider in designing power and ground is noise filtering. A noise filtering circuit is designed to prevent noise generated by the integrated circuit (IC) as well as noise entering the IC from other devices. A common filtering method is to place by-pass capacitors ( $C_{bp}$ ) between the power and ground lines.

Placing a by-pass capacitor ( $C_{bp}$ ) with the correct value at the proper location solves many power supply noise problems. Choosing the correct capacitor value is based upon the desired noise filtering range. Since capacitors are not ideal, they may act more like inductors or resistors over a specific frequency range. Thus, many times two by-pass capacitors may be used to filter a wider bandwidth of noise. It is highly recommended to place a larger capacitor, such as  $10\mu\text{F}$ , between the power supply pin and ground to filter out low frequencies and a  $0.1\mu\text{F}$  to filter out high frequencies.

By-pass capacitors must be mounted as close as possible to the IC to be effective. Long leads produce higher impedance at higher frequencies due to stray inductance. Thus, this will reduce the by-pass capacitor's effectiveness. Surface mounted chip capacitors are the best solution because they have lower inductance.

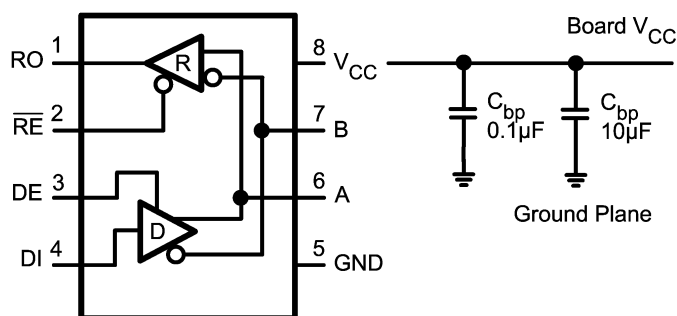

Figure 21. Placement of By-pass Capacitors,  $C_{bp}$

---

**REVISION HISTORY**

<b>Changes from Revision A (April 2013) to Revision B</b>	<b>Page</b>
<hr/> <ul style="list-style-type: none"><li>• Changed layout of National Data Sheet to TI format .....</li></ul>	<hr/> <a href="#">12</a>

## IMPORTANT NOTICE

Texas Instruments Incorporated and its subsidiaries (TI) reserve the right to make corrections, enhancements, improvements and other changes to its semiconductor products and services per JESD46, latest issue, and to discontinue any product or service per JESD48, latest issue. Buyers should obtain the latest relevant information before placing orders and should verify that such information is current and complete. All semiconductor products (also referred to herein as "components") are sold subject to TI's terms and conditions of sale supplied at the time of order acknowledgment.

TI warrants performance of its components to the specifications applicable at the time of sale, in accordance with the warranty in TI's terms and conditions of sale of semiconductor products. Testing and other quality control techniques are used to the extent TI deems necessary to support this warranty. Except where mandated by applicable law, testing of all parameters of each component is not necessarily performed.

TI assumes no liability for applications assistance or the design of Buyers' products. Buyers are responsible for their products and applications using TI components. To minimize the risks associated with Buyers' products and applications, Buyers should provide adequate design and operating safeguards.

TI does not warrant or represent that any license, either express or implied, is granted under any patent right, copyright, mask work right, or other intellectual property right relating to any combination, machine, or process in which TI components or services are used. Information published by TI regarding third-party products or services does not constitute a license to use such products or services or a warranty or endorsement thereof. Use of such information may require a license from a third party under the patents or other intellectual property of the third party, or a license from TI under the patents or other intellectual property of TI.

Reproduction of significant portions of TI information in TI data books or data sheets is permissible only if reproduction is without alteration and is accompanied by all associated warranties, conditions, limitations, and notices. TI is not responsible or liable for such altered documentation. Information of third parties may be subject to additional restrictions.

Resale of TI components or services with statements different from or beyond the parameters stated by TI for that component or service voids all express and any implied warranties for the associated TI component or service and is an unfair and deceptive business practice. TI is not responsible or liable for any such statements.

Buyer acknowledges and agrees that it is solely responsible for compliance with all legal, regulatory and safety-related requirements concerning its products, and any use of TI components in its applications, notwithstanding any applications-related information or support that may be provided by TI. Buyer represents and agrees that it has all the necessary expertise to create and implement safeguards which anticipate dangerous consequences of failures, monitor failures and their consequences, lessen the likelihood of failures that might cause harm and take appropriate remedial actions. Buyer will fully indemnify TI and its representatives against any damages arising out of the use of any TI components in safety-critical applications.

In some cases, TI components may be promoted specifically to facilitate safety-related applications. With such components, TI's goal is to help enable customers to design and create their own end-product solutions that meet applicable functional safety standards and requirements. Nonetheless, such components are subject to these terms.

No TI components are authorized for use in FDA Class III (or similar life-critical medical equipment) unless authorized officers of the parties have executed a special agreement specifically governing such use.

Only those TI components which TI has specifically designated as military grade or "enhanced plastic" are designed and intended for use in military/aerospace applications or environments. Buyer acknowledges and agrees that any military or aerospace use of TI components which have **not** been so designated is solely at the Buyer's risk, and that Buyer is solely responsible for compliance with all legal and regulatory requirements in connection with such use.

TI has specifically designated certain components as meeting ISO/TS16949 requirements, mainly for automotive use. In any case of use of non-designated products, TI will not be responsible for any failure to meet ISO/TS16949.

### Products

Audio	<a href="http://www.ti.com/audio">www.ti.com/audio</a>
Amplifiers	<a href="http://amplifier.ti.com">amplifier.ti.com</a>
Data Converters	<a href="http://dataconverter.ti.com">dataconverter.ti.com</a>
DLP® Products	<a href="http://www.dlp.com">www.dlp.com</a>
DSP	<a href="http://dsp.ti.com">dsp.ti.com</a>
Clocks and Timers	<a href="http://www.ti.com/clocks">www.ti.com/clocks</a>
Interface	<a href="http://interface.ti.com">interface.ti.com</a>
Logic	<a href="http://logic.ti.com">logic.ti.com</a>
Power Mgmt	<a href="http://power.ti.com">power.ti.com</a>
Microcontrollers	<a href="http://microcontroller.ti.com">microcontroller.ti.com</a>
RFID	<a href="http://www.ti-rfid.com">www.ti-rfid.com</a>
OMAP Applications Processors	<a href="http://www.ti.com/omap">www.ti.com/omap</a>
Wireless Connectivity	<a href="http://www.ti.com/wirelessconnectivity">www.ti.com/wirelessconnectivity</a>

### Applications

Automotive and Transportation	<a href="http://www.ti.com/automotive">www.ti.com/automotive</a>
Communications and Telecom	<a href="http://www.ti.com/communications">www.ti.com/communications</a>
Computers and Peripherals	<a href="http://www.ti.com/computers">www.ti.com/computers</a>
Consumer Electronics	<a href="http://www.ti.com/consumer-apps">www.ti.com/consumer-apps</a>
Energy and Lighting	<a href="http://www.ti.com/energy">www.ti.com/energy</a>
Industrial	<a href="http://www.ti.com/industrial">www.ti.com/industrial</a>
Medical	<a href="http://www.ti.com/medical">www.ti.com/medical</a>
Security	<a href="http://www.ti.com/security">www.ti.com/security</a>
Space, Avionics and Defense	<a href="http://www.ti.com/space-avionics-defense">www.ti.com/space-avionics-defense</a>
Video and Imaging	<a href="http://www.ti.com/video">www.ti.com/video</a>

### TI E2E Community

[e2e.ti.com](http://e2e.ti.com)