

LMH6704 650 MHz Selectable Gain Buffer with Disable

Check for Samples: [LMH6704](#)

FEATURES

- **Wideband operation**
 - $A_V = +1$, $V_O = 0.5 V_{PP}$ 650 MHz
 - $A_V = +2$, $V_O = 0.5 V_{PP}$ 450 MHz
 - $A_V = +2$, $V_O = 2 V_{PP}$ 400 MHz
- **High output current ± 90 mA**
- **Very low distortion**
 - 2nd/3rd harmonics (10 MHz, $R_L = 100\Omega$): –62/–78dBc
 - Differential gain/Differential phase: 0.02%/0.02°
- **Low noise $2.3nV/\sqrt{Hz}$**
- **High slew rate 3000 V/ μ s**
- **Supply current 11.5 mA**

APPLICATIONS

- **HDTV, NTSC and PAL video systems**
- **Video switching and distribution**
- **ADC driver**
- **DAC buffer**
- **RGB driver**
- **High speed multiplexer**

DESCRIPTION

The LMH™6704 is a very wideband, DC coupled selectable gain buffer designed specifically for wide dynamic range systems requiring exceptional signal fidelity. The LMH6704 includes on chip feedback and gain set resistors, simplifying PCB layout while providing user selectable gains of +1, +2 and –1 V/V. The LMH6704 provides a disable pin, which places the amplifier in a high output impedance, low power mode. The Disable pin may be allowed to float high.

With a 650 MHz Small Signal Bandwidth ($A_V = +1$), full power gain flatness to 200 MHz, and excellent Differential Gain and Phase, the LMH6704 is optimized for video applications. High resolution video systems will benefit from the LMH6704 ability to drive multiple video loads at low levels of differential gain or differential phase distortion.

The LMH6704 is constructed with proprietary high speed complementary bipolar process using proven current feedback circuit architectures. It is available in 8 Pin SOIC and 6 Pin SOT-23 packages.

CONNECTION DIAGRAM

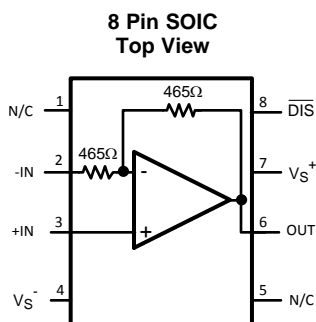

See Package Number D0008A

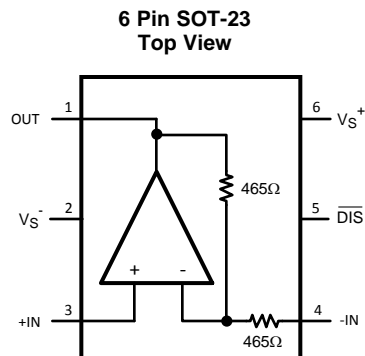

See Package Number DBV0006A



Please be aware that an important notice concerning availability, standard warranty, and use in critical applications of Texas Instruments semiconductor products and disclaimers thereto appears at the end of this data sheet.

LMH is a trademark of Texas Instruments.

All other trademarks are the property of their respective owners.



These devices have limited built-in ESD protection. The leads should be shorted together or the device placed in conductive foam during storage or handling to prevent electrostatic damage to the MOS gates.

Absolute Maximum Ratings ⁽¹⁾

ESD Tolerance ⁽²⁾	Human Body Model	2000V
	Machine Model	200V
Supply Voltage		13.5V
I_{OUT}		⁽³⁾
Common-Mode Input Voltage		V_S^- to V_S^+
Maximum Junction Temperature		150°C
Storage Temperature Range		-65°C to 150°C
Soldering Information	Infrared or Convection (20 sec.)	235°C
	Wave Soldering (10 sec.)	260°C
	Lead Temp. (soldering 10 sec.)	300°C

- (1) Absolute Maximum Ratings indicate limits beyond which damage to the device may occur. Operating Ratings indicate conditions for which the device is intended to be functional, but specific performance is not ensured. For specifications, see the Electrical Characteristics tables.
- (2) Human Body Model, applicable std. MIL-STD-883, Method 3015.7. Machine Model, applicable std. JESD22-A115-A (ESD MM std. of JEDEC). Field-Induced Charge-Device Model, applicable std. JESD22-C101-C (ESD FICDM std. of JEDEC).
- (3) The maximum output current (I_{OUT}) is determined by device power dissipation limitations.

Operating Ratings ⁽¹⁾

Nominal Supply Voltage		$\pm 4V$ to $\pm 6V$
Temperature Range ⁽²⁾		-40°C to 85°C
Thermal Resistance		
Package	(θ_{JC})	(θ_{JA})
8-Pin SOIC	75°C/W	160°C/W
6-Pin SOT23	120°C/W	187°C/W

- (1) Absolute Maximum Ratings indicate limits beyond which damage to the device may occur. Operating Ratings indicate conditions for which the device is intended to be functional, but specific performance is not ensured. For specifications, see the Electrical Characteristics tables.
- (2) The maximum power dissipation is a function of $T_{J(MAX)}$, θ_{JA} . The maximum allowable power dissipation at any ambient temperature is $P_D = (T_{J(MAX)} - T_A) / \theta_{JA}$. All numbers apply for packages soldered directly onto a PC Board.

Electrical Characteristics ⁽¹⁾
 $T_A = +25^\circ\text{C}$, $A_V = +2$, $V_S = \pm 5\text{V}$, $R_L = 100\Omega$; unless specified.

Symbol	Parameter	Conditions	Min ⁽²⁾	Typ ⁽²⁾	Max ⁽²⁾	Units
Dynamic Performance						
SSBW	-3 dB Bandwidth	$V_{OUT} = 0.5 V_{PP}$, $A_V = +1$		650		MHz
SSBW		$V_{OUT} = 0.5 V_{PP}$		450		
LSBW		$V_{OUT} = 2 V_{PP}$		400		
$GF_{0.1dB}$	0.1 dB Gain Bandwidth	$V_{OUT} = 2 V_{PP}$		200		MHz
SR	Slew Rate	$V_{OUT} = 4 V_{PP}$, 40% to 60% ⁽³⁾		3000		V/ μs
TRS/TRL	Rise and Fall Time (10% to 90%)	2V Step		0.9		ns
t_s	Settling Time to 0.1%	2V Step		10		ns
Distortion and Noise Response						
HD2L	2 nd Harmonic Distortion	$V_{OUT} = 2.0 V_{PP}$, $f = 10\text{ MHz}$		-62		dBc
HD2H		$V_{OUT} = 2.0 V_{PP}$, $f = 40\text{ MHz}$		-52		
HD3L	3 rd Harmonic Distortion	$V_{OUT} = 2.0 V_{PP}$, $f = 10\text{ MHz}$		-78		dBc
HD3H		$V_{OUT} = 2.0 V_{PP}$, $f = 40\text{ MHz}$		-65		
IMD	Two-Tone Intermodulation	$f = 10\text{ MHz}$, $P_{OUT} = 10\text{ dBm/tone}$		-65		dBc
V_N	Output Noise Voltage	$f = 100\text{ kHz}$	$A_V = +2$	10.5		nV/ $\sqrt{\text{Hz}}$
			$A_V = +1$	9.3		
			$A_V = -1$	10.5		
I_{NN}	Non-Inverting Input Noise Current			3		pA/ $\sqrt{\text{Hz}}$
DG	Differential Gain	$R_L = 150\Omega$, $f = 4.43\text{ MHz}$.02		%
DP	Differential Phase	$R_L = 150\Omega$, $f = 4.43\text{ MHz}$		0.02		deg
Static, DC Performance						
A_V	Gain		1.98 1.96	2.00	2.02 2.04	V/V
	Gain Error		-1 -2		+1 +2	%
V_{IO}	Input Offset Voltage			2	± 7 ± 8.3	mV
DV_{IO}	Input Offset Voltage Average Drift			35		$\mu\text{V}/^\circ\text{C}$
I_{BN}	Input Bias Current	Non-Inverting ⁽⁴⁾		-5	± 15 ± 18	μA
I_{BI}	Input Bias Current	Inverting		5	± 22 ± 31	
CMIR	Common Mode Input Range	$V_{IO} \leq 15\text{ mV}$	± 1.9	± 2		V
PSRR	Power Supply Rejection Ratio	DC	48 47	52		dB
V_O	Output Voltage Swing	$R_L = \infty$	± 3.3 ± 3.18	± 3.5		V
		$R_L = 100\Omega$	± 3.2 ± 3.12	± 3.5		
I_O	Linear Output Current	$V_{OUT} \leq 80\text{ mV}$	± 55	± 90		mA
I_S	Supply Current (Enabled)	$\overline{DIS} = 2\text{V}$, $R_L = \infty$		11.5	12.5 13.7	mA
	Supply Current (Disabled)	$\overline{DIS} = 0.8\text{V}$, $R_L = \infty$		0.25	0.9 0.925	

(1) Electrical Table values apply only for factory testing conditions at the temperature indicated. Factory testing conditions result in very limited self-heating of the device such that $T_J = T_A$. Parametric performance is indicated in the electrical tables under conditions of internal self-heating where $T_J > T_A$. Min/Max ratings are based on production testing unless otherwise specified.

(2) Typical values represent the most likely parametric norm as determined at the time of characterization. Actual typical values may vary over time and will also depend on the application and configuration. The typical values are not tested on shipped production material.

(3) Slew Rate is the average of the rising and falling edges.

(4) Negative current implies current flowing out of the device.

Electrical Characteristics ⁽¹⁾ (continued)

$T_A = +25^\circ\text{C}$, $A_V = +2$, $V_S = \pm 5\text{V}$, $R_L = 100\Omega$; unless specified.

Symbol	Parameter	Conditions	Min ⁽²⁾	Typ ⁽²⁾	Max ⁽²⁾	Units
R_F & R_G	Internal R_F and R_G		375	465	563	Ω
R_{OUT}	Closed Loop Output Resistance	DC		0.05		Ω
R_{IN+}	Input Resistance			1		$M\Omega$
C_{IN+}	Input Capacitance			1		pF
Enable/Disable Performance (Disabled Low)						
T_{ON}	Enable Time			10		ns
T_{OFF}	Disable Time			10		ns
	Output Glitch			50		mV _{PP}
V_{IH}	Enable Voltage	$\overline{DIS} \geq V_{IH}$	2.0			V
V_{IL}	Disable Voltage	$\overline{DIS} \leq V_{IL}$			0.8	
I_{IH}	Disable Input Bias Current, High	$\overline{DIS} = V^+$, ⁽⁴⁾		-1	±50	μA
I_{IL}	Disable Input Bias Current, Low	$\overline{DIS} = 0\text{V}$ ⁽⁴⁾	0	-100	-350	μA
I_{OZ}	Disabled Output Leakage Current	$A_V = +1$, $V_{OUT} = \pm 1.8\text{V}$		0.2	±25 ±50	μA

Typical Performance Characteristics

($T_A = 25^\circ\text{C}$, $V_S = \pm 5\text{V}$, $R_L = 100\Omega$, $A_V = +2$, $V_{OUT} = 0.5 V_{PP}$; Unless Specified).

Small Signal Frequency Response vs. Gain

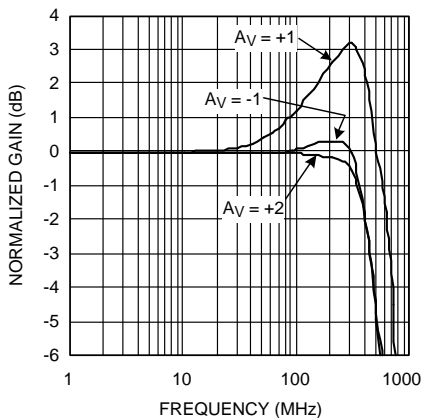

Figure 1.

Frequency Response vs. V_{OUT}

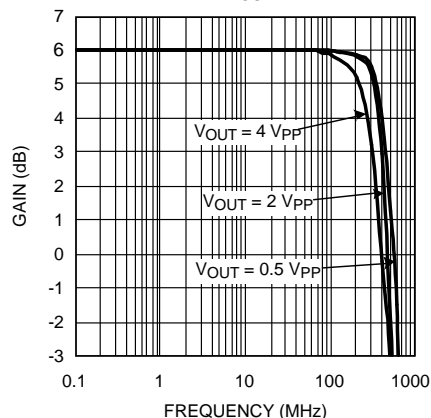

Figure 2.

Small Signal Frequency Response vs. R_{LOAD}

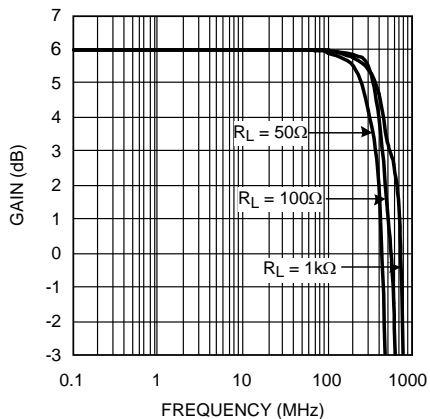

Figure 3.

Large Signal Gain Flatness

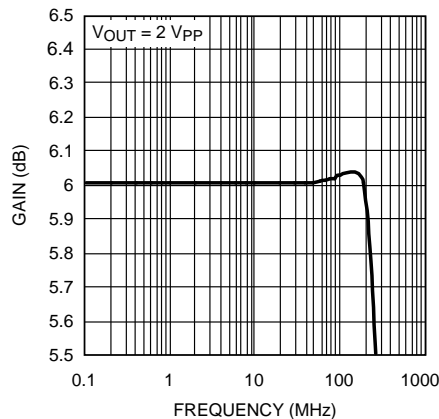

Figure 4.

Small Signal Frequency Response vs. Capacitive Load

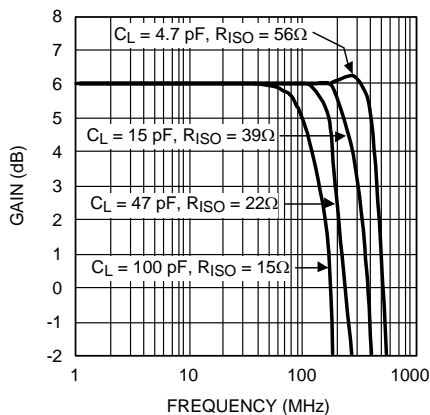

Figure 5.

Series Output Isolation Resistance vs. Capacitive Load

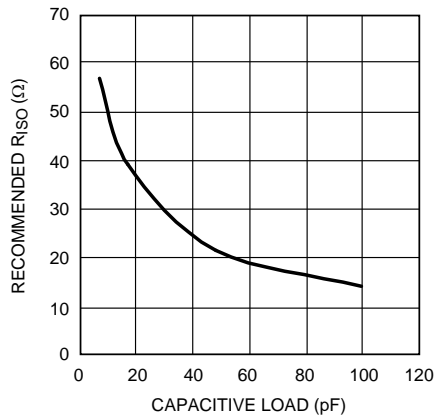
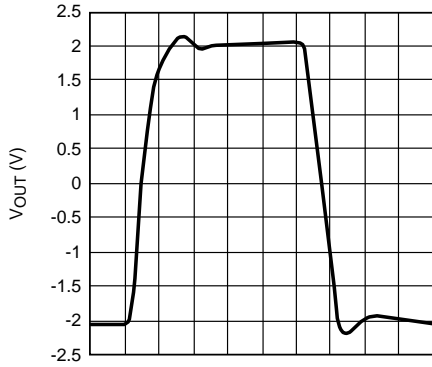

Figure 6.

Typical Performance Characteristics (continued)

($T_A = 25^\circ\text{C}$, $V_S = \pm 5\text{V}$, $R_L = 100\Omega$, $A_V = +2$, $V_{OUT} = 0.5\text{ V}_{PP}$; Unless Specified).

Large Signal Pulse Response



TIME (2 ns/div)
Figure 7.

Small Signal Pulse Response

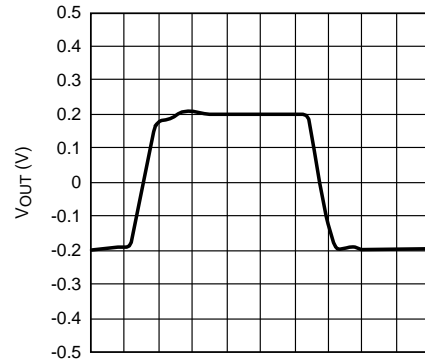

TIME (2 ns/div)
Figure 8.

Harmonic Distortion vs. Frequency

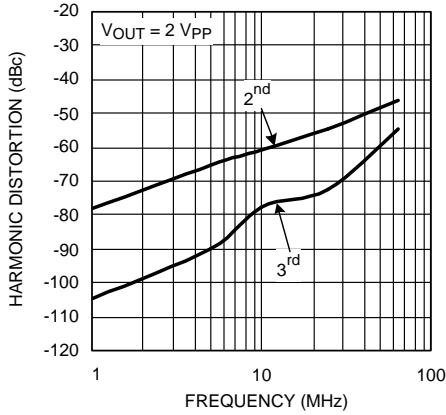

Figure 9.

Harmonic Distortion vs. Load

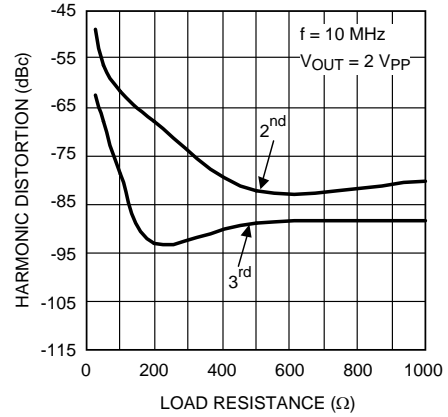

Figure 10.

Harmonic Distortion vs. Output Voltage

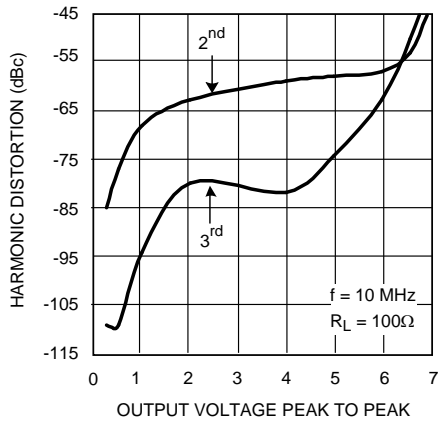

Figure 11.

DG/DP

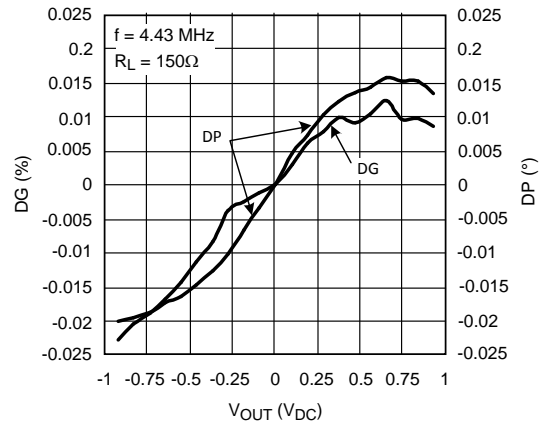

Figure 12.

Typical Performance Characteristics (continued)

($T_A = 25^\circ\text{C}$, $V_S = \pm 5\text{V}$, $R_L = 100\Omega$, $A_V = +2$, $V_{OUT} = 0.5 V_{PP}$; Unless Specified).

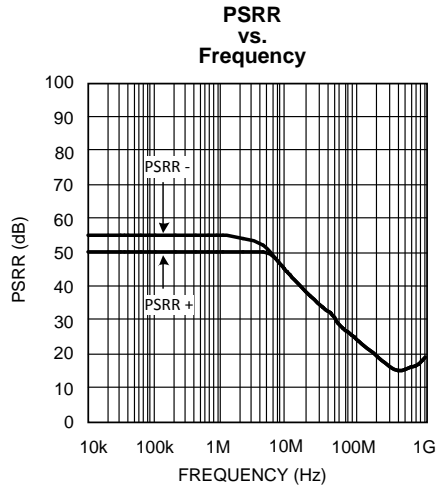

Figure 13.

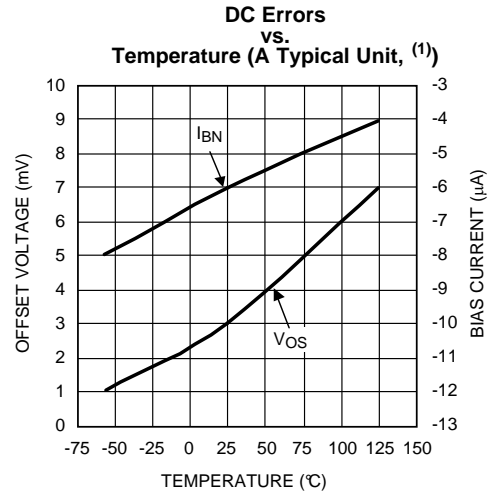

Figure 14.

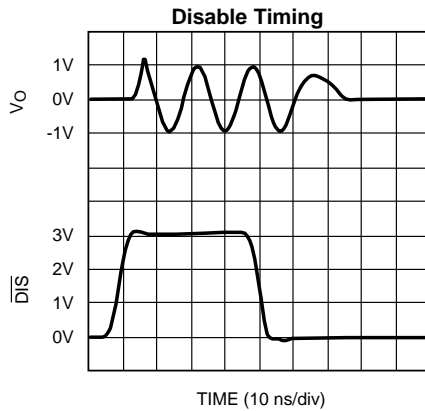

Figure 15.

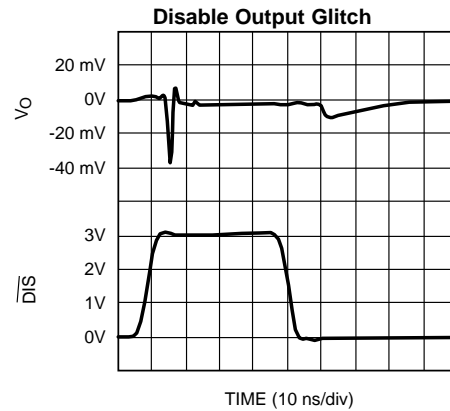

Figure 16.

(1) Negative current implies current flowing out of the device.

APPLICATION INFORMATION

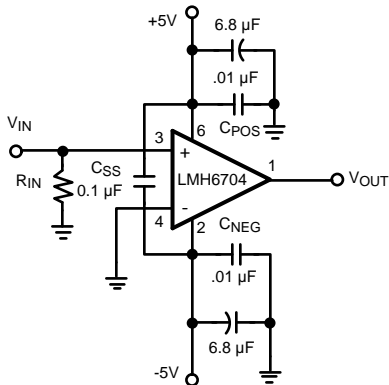

Figure 17. Recommended Gain of +2 Circuit

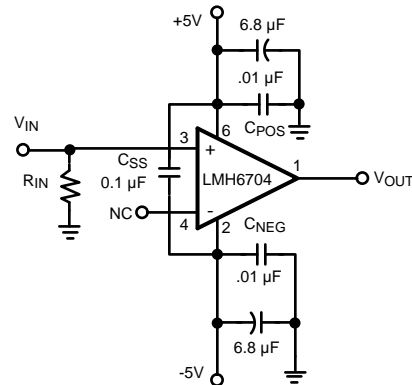

Figure 18. Recommended Gain of +1 Circuit

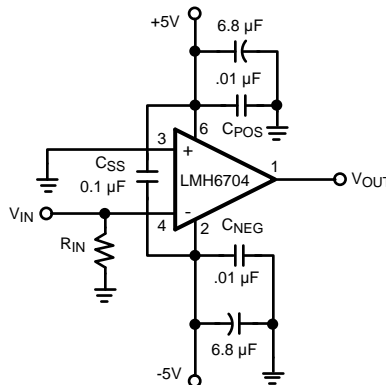

Figure 19. Recommended Gain of -1 Circuit

GENERAL INFORMATION

The LMH6704 is a high speed current feedback Selectable Gain Buffer (SGB), optimized for very high speed and low distortion. With its internal feedback and gain-setting resistors the LMH6704 offers excellent AC performance while simplifying board layout and minimizing the affects of layout related parasitic components. The LMH6704 has no internal ground reference so single or split supply configurations are both equally useful.

SETTING THE CLOSED LOOP GAIN

The LMH6704 is a current feedback amplifier with on-chip $R_F = R_G = 465\Omega$. As such it can be configured with an $A_V = +2$, $A_V = +1$, or an $A_V = -1$ by connecting pins 3 and 4 as described in Table 1.

Table 1.

GAIN A_V	Input Connections	
	Non-Inverting (Pin 3, SOT-23)	Inverting (Pin 4, SOT-23)
-1 V/V	Ground	Input Signal
+1 V/V	Input Signal	NC (Open)
+2 V/V	Input Signal	Ground

The gain accuracy of the LMH6704 is accurate over temperature to within $\pm 1\%$. The internal gain setting resistors, R_F and R_G , match very well. The LMH6704 architecture takes advantage of the fact that the internal gain setting resistors track each other well over a wide range of temperature and process variation to keep the overall gain constant, despite the fact that the individual resistors have nominal temperature drifts. Therefore, using external resistors in series with R_G to change the gain will result in poor gain accuracy over temperature.

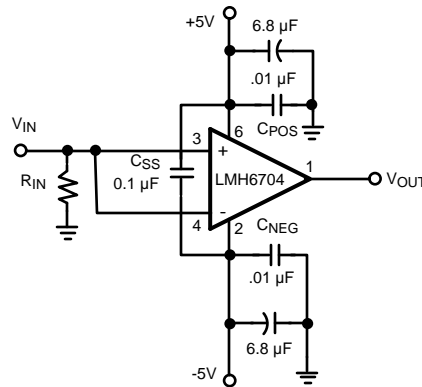

Figure 20. Alternate Unity Gain Configuration

UNITY GAIN COMPENSATION

With a current feedback Selectable Gain Buffer like the LMH6704, the feedback resistor is a compromise between the value needed for stability at unity gain and the optimized value needed at a gain of two. In standard open-loop current feedback operational amplifiers the feedback resistor, R_F , is external and its value can be adjusted to match the required gain. Since the feedback resistor is integrated in the LMH6704, it is not possible to adjust its value. However, we can employ the circuit shown in Figure 20. This circuit modifies the noise gain of the amplifier to eliminate the peaking associated with using the circuit shown in Figure 18. The frequency response is shown in Figure 21. The decreased peaking does come at a price as the output referred voltage noise density increases by a factor of 1.1.

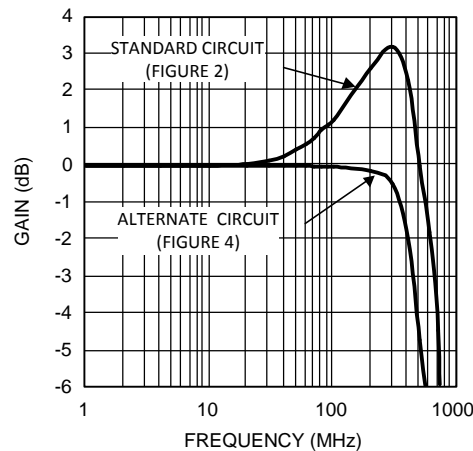

Figure 21. Unity Gain Frequency Response

OUTPUT VOLTAGE NOISE

Open-loop operational amplifiers specify three input referred noise parameters: input voltage noise, non-inverting input current noise, and inverting input current noise. These specifications are used to calculate the total voltage noise produced at the output of the amplifier. The LMH6704 is a closed loop amplifier with internal resistors, thus only the non-inverting input current noise flows through external components. All other noise sources are internal to the part. There are four possible values for the noise at the output depending on the gain configuration as shown in Table 2. For more information on calculating noise in current feedback amplifiers see Application Notes OA-12 and AN104 available at www.ti.com.

The total noise voltage at the output can be calculated using Equation 1:

$$E_O = \sqrt{(4kTR_{SOURCE} + (I_{BN} * R_{SOURCE})^2) * G_N^2 + (OUTPUT REFERRED NOISE VOLTAGE)^2}, \text{ Where}$$

$$G_N = \text{Noise Gain and } 4kT = 16E-21 \text{ Joules @ Room Temperature} \quad (1)$$

For example, if an $A_V = +2$ configuration is used with a source impedance of 37.5Ω (parallel combination of 75Ω source and 75Ω termination impedances), where " I_{BN} " is $18.5\text{pA}/\sqrt{\text{Hz}}$ and the output referred voltage noise (excluding non-inverting input noise current) can be found in Table 2. The total noise (E_O) at the output can be calculated as:

$$E_O = \sqrt{(16E-21 * 37.5 + (18.5 \text{ pA} * 37.5)^2) * 2^2 + (10.5 \text{ nV})^2} = 10.6 \text{ nV} / \sqrt{\text{Hz}} \quad (2)$$

Table 2. Measured Output Noise Voltage⁽¹⁾

Gain (A_V)	Output Referred Voltage Noise ($\text{nV}/\sqrt{\text{Hz}}$), excluding non-inverting noise current
+2	10.5
+1	9.3
+1, alternate method shown in Figure 20	10.5
-1	10.5

(1) Note: $f \geq 100 \text{ kHz}$

ENABLE/DISABLE

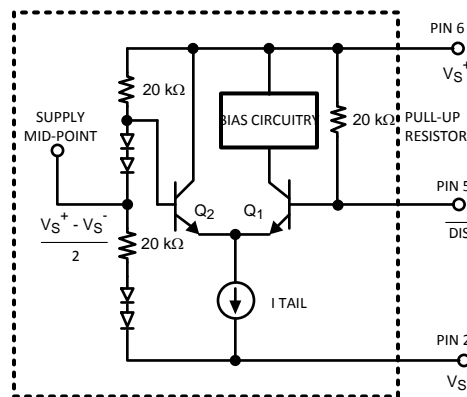

NOTE: PINS 2, 5, 6 ARE EXTERNAL

Figure 22. DIS Pin Simplified Schematic

The LMH6704 has a TTL logic compatible disable function. Apply a logic low ($<.8\text{V}$) to the DS pin and the LMH6704 is disabled. Apply a logic high ($>2.0\text{V}$), or let the pin float and the LMH6704 is enabled. Voltage, not current, at the Disable pin (DS) determines the enable/disable state. Care must be exercised to prevent the disable pin voltage from going more than $.8\text{V}$ below the midpoint of the supply voltages (0V with split supplies, $V^+/2$ with single supply biasing). Doing so could cause transistor Q1 to Zener resulting in damage to the disable circuit (See Figure 22 or the simplified internal schematic diagram using SOT-23 package pin numbers). The core amplifier is unaffected by this, but the disable operation could become permanently slower as a result.

Disabled, the LMH6704 inputs and output become high impedances. While disabled the LMH6704 quiescent current is approximately $250 \mu\text{A}$. Because of the pull up resistor on the disable circuit, the I_{CC} and I_{EE} currents (positive and negative supply currents respectively) are not balanced in the disabled state. The positive supply current (I_{CC}) is approximately $350 \mu\text{A}$ while the negative supply current (I_{EE}) is only $250 \mu\text{A}$. The remaining I_{EE} current of $100 \mu\text{A}$ flows through the disable pin.

The disable function can be used to create analog switches or multiplexers. Implement a single analog switch with one LMH6704 positioned between an input and output. Create an analog multiplexer with several LMH6704's. Use the circuit shown in for multiplexer applications because there is no R_G to shunt signals to ground.

EVALUATION BOARDS

Texas Instruments provides the following evaluation boards as a guide for high frequency layout and as an aid in device testing and characterization. Many of the data sheet plots were measured with these boards.

Device	Package	Evaluation Board Part Number
LMH6704MA	SOIC-8	CLC730227
LMH6704MF	SOT23-6	CLC730216

DRIVING CAPACITIVE LOADS

Capacitive output loading applications will benefit from the use of a series output resistor R_{ISO} . Figure 23 shows the use of a series output resistor, R_{ISO} , to stabilize the amplifier output under capacitive loading. Capacitive loads of 5 to 120 pF are the most critical, causing ringing, frequency response peaking and possible oscillation. The chart “Suggested R_{ISO} vs. Cap Load” gives a recommended value for selecting a series output resistor for mitigating capacitive loads. The values suggested in the charts are selected for 0.5 dB or less of peaking in the frequency response. This gives a good compromise between settling time and bandwidth. For applications where maximum frequency response is needed and some peaking is tolerable, the value of R_{ISO} can be reduced slightly from the recommended values.

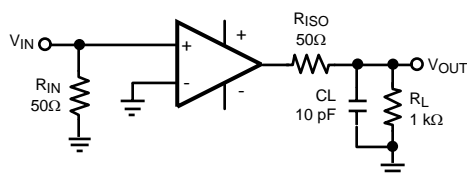

Figure 23. Decoupling Capacitive Loads

LAYOUT CONSIDERATIONS

Whenever questions about layout arise, use the evaluation board as a guide. To reduce parasitic capacitances ground and power planes should be removed near the input and output pins. For long signal paths controlled impedance lines should be used, along with impedance matching elements at both ends. Bypass capacitors should be placed as close to the device as possible. Bypass capacitors from each rail to ground are applied in pairs. The larger electrolytic bypass capacitors can be located farther from the device, the smaller ceramic capacitors should be placed as close to the device as possible. In Figure 17, Figure 18, and Figure 19 C_{SS} is optional, but is recommended for best second order harmonic distortion. Another option to using C_{SS} is to use pairs of 0.01 μ F and 0.1 μ F ceramic capacitors for each supply bypass.

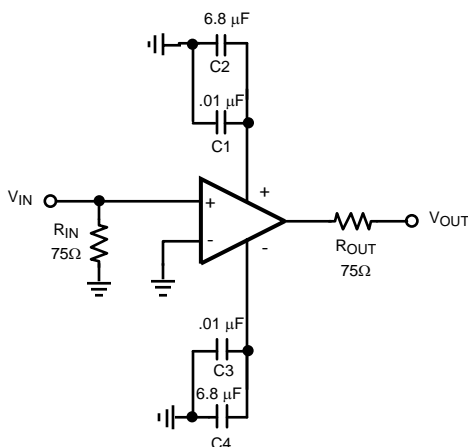

Figure 24. Typical Video Application

VIDEO PERFORMANCE

The LMH6704 has been designed to provide excellent performance with production quality video signals in a wide variety of formats such as HDTV and High Resolution VGA. NTSC and PAL performance is nearly flawless with DG of 0.02% and DP of 0.02°. Best performance will be obtained with back terminated loads. The back termination reduces reflections from the transmission line and effectively masks transmission line and other parasitic capacitances from the amplifier output stage. [Figure 24](#) shows a typical configuration for driving a 75Ω Cable. The amplifier is configured for a gain of two to make up for the 6 dB of loss in R_{OUT} .

POWER DISSIPATION

Follow these steps to determine the Maximum power dissipation for the LMH6704:

1. Calculate the quiescent (no-load) power:

$$P_{AMP} = I_{CC} \cdot (V_S) \quad (3)$$

where $V_S = V^+ - V^-$

2. Calculate the RMS power dissipated in the output stage:

$$P_D \text{ (rms)} = \text{rms} ((V_S - V_{OUT}) \times I_{OUT}) \quad (4)$$

where V_{OUT} and I_{OUT} are the voltage and current across the external load and V_S is the total supply current

3. Calculate the total RMS power:

$$P_T = P_{AMP} + P_D \quad (5)$$

The maximum power that the LMH6704, package can dissipate at a given temperature can be derived with the following equation:

$P_{MAX} = (150^\circ - T_{AMB}) / \theta_{JA}$, where T_{AMB} = Ambient temperature ($^\circ\text{C}$) and θ_{JA} = Thermal resistance, from junction to ambient, for a given package ($^\circ\text{C}/\text{W}$). For the SOT-23 package θ_{JA} is $187^\circ\text{C}/\text{W}$.

ESD PROTECTION

The LMH6704 is protected against electrostatic discharge (ESD) on all pins. The LMH6704 will survive 2000V Human Body model and 200V Machine model events. Input and Output pins have ESD diodes to either supply pin (V^+ and V^-) which are reverse biased and essentially have no effect under most normal operating conditions. There are occasions, however, when the ESD diodes will be evident. If the LMH6704 is driven by a large signal while the device is powered down, the ESD diodes might enter forward operating region and conduct. The current that flows through the ESD diodes will either exit the chip through the supply pins or will flow through the device, hence it is possible to inadvertently power up the LMH6704 with a large signal applied to the input pins. Shorting the power pins to each other will prevent the chip from being powered up through the input.

REVISION HISTORY

Changes from Revision B (March 2013) to Revision C	Page
<hr/> <ul style="list-style-type: none">• Changed layout of National Data Sheet to TI format	<hr/> 12

PACKAGING INFORMATION

Orderable Device	Status (1)	Package Type	Package Drawing	Pins	Package Qty	Eco Plan (2)	Lead/Ball Finish	MSL Peak Temp (3)	Op Temp (°C)	Top-Side Markings (4)	Samples
LMH6704MA	ACTIVE	SOIC	D	8	95	TBD	Call TI	Call TI	-40 to 85	LMH6704MA	Samples
LMH6704MA/NOPB	ACTIVE	SOIC	D	8	95	Green (RoHS & no Sb/Br)	CU SN	Level-1-260C-UNLIM	-40 to 85	LMH6704MA	Samples
LMH6704MAX	ACTIVE	SOIC	D	8	2500	TBD	Call TI	Call TI	-40 to 85	LMH6704MA	Samples
LMH6704MAX/NOPB	ACTIVE	SOIC	D	8	2500	Green (RoHS & no Sb/Br)	CU SN	Level-1-260C-UNLIM	-40 to 85	LMH6704MA	Samples
LMH6704MF	ACTIVE	SOT-23	DBV	6	1000	TBD	Call TI	Call TI	-40 to 85	B07A	Samples
LMH6704MF/NOPB	ACTIVE	SOT-23	DBV	6	1000	Green (RoHS & no Sb/Br)	CU SN	Level-1-260C-UNLIM	-40 to 85	B07A	Samples
LMH6704MFX/NOPB	ACTIVE	SOT-23	DBV	6	3000	Green (RoHS & no Sb/Br)	CU SN	Level-1-260C-UNLIM	-40 to 85	B07A	Samples

(1) The marketing status values are defined as follows:

ACTIVE: Product device recommended for new designs.

LIFEBUY: TI has announced that the device will be discontinued, and a lifetime-buy period is in effect.

NRND: Not recommended for new designs. Device is in production to support existing customers, but TI does not recommend using this part in a new design.

PREVIEW: Device has been announced but is not in production. Samples may or may not be available.

OBSOLETE: TI has discontinued the production of the device.

(2) Eco Plan - The planned eco-friendly classification: Pb-Free (RoHS), Pb-Free (RoHS Exempt), or Green (RoHS & no Sb/Br) - please check <http://www.ti.com/productcontent> for the latest availability information and additional product content details.

TBD: The Pb-Free/Green conversion plan has not been defined.

Pb-Free (RoHS): TI's terms "Lead-Free" or "Pb-Free" mean semiconductor products that are compatible with the current RoHS requirements for all 6 substances, including the requirement that lead not exceed 0.1% by weight in homogeneous materials. Where designed to be soldered at high temperatures, TI Pb-Free products are suitable for use in specified lead-free processes.

Pb-Free (RoHS Exempt): This component has a RoHS exemption for either 1) lead-based flip-chip solder bumps used between the die and package, or 2) lead-based die adhesive used between the die and leadframe. The component is otherwise considered Pb-Free (RoHS compatible) as defined above.

Green (RoHS & no Sb/Br): TI defines "Green" to mean Pb-Free (RoHS compatible), and free of Bromine (Br) and Antimony (Sb) based flame retardants (Br or Sb do not exceed 0.1% by weight in homogeneous material)

(3) MSL, Peak Temp. -- The Moisture Sensitivity Level rating according to the JEDEC industry standard classifications, and peak solder temperature.

(4) Multiple Top-Side Markings will be inside parentheses. Only one Top-Side Marking contained in parentheses and separated by a "~" will appear on a device. If a line is indented then it is a continuation of the previous line and the two combined represent the entire Top-Side Marking for that device.

Important Information and Disclaimer: The information provided on this page represents TI's knowledge and belief as of the date that it is provided. TI bases its knowledge and belief on information provided by third parties, and makes no representation or warranty as to the accuracy of such information. Efforts are underway to better integrate information from third parties. TI has taken and continues to take reasonable steps to provide representative and accurate information but may not have conducted destructive testing or chemical analysis on incoming materials and chemicals. TI and TI suppliers consider certain information to be proprietary, and thus CAS numbers and other limited information may not be available for release.

In no event shall TI's liability arising out of such information exceed the total purchase price of the TI part(s) at issue in this document sold by TI to Customer on an annual basis.

TAPE AND REEL INFORMATION

QUADRANT ASSIGNMENTS FOR PIN 1 ORIENTATION IN TAPE

*All dimensions are nominal

Device	Package Type	Package Drawing	Pins	SPQ	Reel Diameter (mm)	Reel Width W1 (mm)	A0 (mm)	B0 (mm)	K0 (mm)	P1 (mm)	W (mm)	Pin1 Quadrant
LMH6704MAX	SOIC	D	8	2500	330.0	12.4	6.5	5.4	2.0	8.0	12.0	Q1
LMH6704MAX/NOPB	SOIC	D	8	2500	330.0	12.4	6.5	5.4	2.0	8.0	12.0	Q1
LMH6704MF	SOT-23	DBV	6	1000	178.0	8.4	3.2	3.2	1.4	4.0	8.0	Q3
LMH6704MF/NOPB	SOT-23	DBV	6	1000	178.0	8.4	3.2	3.2	1.4	4.0	8.0	Q3
LMH6704MFX/NOPB	SOT-23	DBV	6	3000	178.0	8.4	3.2	3.2	1.4	4.0	8.0	Q3

TAPE AND REEL BOX DIMENSIONS

*All dimensions are nominal

Device	Package Type	Package Drawing	Pins	SPQ	Length (mm)	Width (mm)	Height (mm)
LMH6704MAX	SOIC	D	8	2500	367.0	367.0	35.0
LMH6704MAX/NOPB	SOIC	D	8	2500	367.0	367.0	35.0
LMH6704MF	SOT-23	DBV	6	1000	210.0	185.0	35.0
LMH6704MF/NOPB	SOT-23	DBV	6	1000	210.0	185.0	35.0
LMH6704MFX/NOPB	SOT-23	DBV	6	3000	210.0	185.0	35.0

DBV (R-PDSO-G6)

PLASTIC SMALL-OUTLINE PACKAGE



- NOTES:
- A. All linear dimensions are in millimeters.
 - B. This drawing is subject to change without notice.
 - C. Body dimensions do not include mold flash or protrusion. Mold flash and protrusion shall not exceed 0.15 per side.
 - D. Leads 1,2,3 may be wider than leads 4,5,6 for package orientation.
- \triangle Falls within JEDEC MO-178 Variation AB, except minimum lead width.

D (R-PDSO-G8)

PLASTIC SMALL OUTLINE



- NOTES:
- A. All linear dimensions are in inches (millimeters).
 - B. This drawing is subject to change without notice.
 - C. Body length does not include mold flash, protrusions, or gate burrs. Mold flash, protrusions, or gate burrs shall not exceed 0.006 (0,15) each side.
 - D. Body width does not include interlead flash. Interlead flash shall not exceed 0.017 (0,43) each side.
 - E. Reference JEDEC MS-012 variation AA.

IMPORTANT NOTICE

Texas Instruments Incorporated and its subsidiaries (TI) reserve the right to make corrections, enhancements, improvements and other changes to its semiconductor products and services per JESD46, latest issue, and to discontinue any product or service per JESD48, latest issue. Buyers should obtain the latest relevant information before placing orders and should verify that such information is current and complete. All semiconductor products (also referred to herein as "components") are sold subject to TI's terms and conditions of sale supplied at the time of order acknowledgment.

TI warrants performance of its components to the specifications applicable at the time of sale, in accordance with the warranty in TI's terms and conditions of sale of semiconductor products. Testing and other quality control techniques are used to the extent TI deems necessary to support this warranty. Except where mandated by applicable law, testing of all parameters of each component is not necessarily performed.

TI assumes no liability for applications assistance or the design of Buyers' products. Buyers are responsible for their products and applications using TI components. To minimize the risks associated with Buyers' products and applications, Buyers should provide adequate design and operating safeguards.

TI does not warrant or represent that any license, either express or implied, is granted under any patent right, copyright, mask work right, or other intellectual property right relating to any combination, machine, or process in which TI components or services are used. Information published by TI regarding third-party products or services does not constitute a license to use such products or services or a warranty or endorsement thereof. Use of such information may require a license from a third party under the patents or other intellectual property of the third party, or a license from TI under the patents or other intellectual property of TI.

Reproduction of significant portions of TI information in TI data books or data sheets is permissible only if reproduction is without alteration and is accompanied by all associated warranties, conditions, limitations, and notices. TI is not responsible or liable for such altered documentation. Information of third parties may be subject to additional restrictions.

Resale of TI components or services with statements different from or beyond the parameters stated by TI for that component or service voids all express and any implied warranties for the associated TI component or service and is an unfair and deceptive business practice. TI is not responsible or liable for any such statements.

Buyer acknowledges and agrees that it is solely responsible for compliance with all legal, regulatory and safety-related requirements concerning its products, and any use of TI components in its applications, notwithstanding any applications-related information or support that may be provided by TI. Buyer represents and agrees that it has all the necessary expertise to create and implement safeguards which anticipate dangerous consequences of failures, monitor failures and their consequences, lessen the likelihood of failures that might cause harm and take appropriate remedial actions. Buyer will fully indemnify TI and its representatives against any damages arising out of the use of any TI components in safety-critical applications.

In some cases, TI components may be promoted specifically to facilitate safety-related applications. With such components, TI's goal is to help enable customers to design and create their own end-product solutions that meet applicable functional safety standards and requirements. Nonetheless, such components are subject to these terms.

No TI components are authorized for use in FDA Class III (or similar life-critical medical equipment) unless authorized officers of the parties have executed a special agreement specifically governing such use.

Only those TI components which TI has specifically designated as military grade or "enhanced plastic" are designed and intended for use in military/aerospace applications or environments. Buyer acknowledges and agrees that any military or aerospace use of TI components which have **not** been so designated is solely at the Buyer's risk, and that Buyer is solely responsible for compliance with all legal and regulatory requirements in connection with such use.

TI has specifically designated certain components as meeting ISO/TS16949 requirements, mainly for automotive use. In any case of use of non-designated products, TI will not be responsible for any failure to meet ISO/TS16949.

Products

Audio	www.ti.com/audio
Amplifiers	amplifier.ti.com
Data Converters	dataconverter.ti.com
DLP® Products	www.dlp.com
DSP	dsp.ti.com
Clocks and Timers	www.ti.com/clocks
Interface	interface.ti.com
Logic	logic.ti.com
Power Mgmt	power.ti.com
Microcontrollers	microcontroller.ti.com
RFID	www.ti-rfid.com
OMAP Applications Processors	www.ti.com/omap
Wireless Connectivity	www.ti.com/wirelessconnectivity

Applications

Automotive and Transportation	www.ti.com/automotive
Communications and Telecom	www.ti.com/communications
Computers and Peripherals	www.ti.com/computers
Consumer Electronics	www.ti.com/consumer-apps
Energy and Lighting	www.ti.com/energy
Industrial	www.ti.com/industrial
Medical	www.ti.com/medical
Security	www.ti.com/security
Space, Avionics and Defense	www.ti.com/space-avionics-defense
Video and Imaging	www.ti.com/video

TI E2E Community

e2e.ti.com