

## LM124AQL LM124QL Low Power Quad Operational Amplifiers

Check for Samples: [LM124AQL](#), [LM124QL](#)

### FEATURES

- Available with Radiation Specification
  - High Dose Rate 100 krad(Si)
  - ELDRS Free 100 krad(Si)
- Internally Frequency Compensated for Unity Gain
- Large DC Voltage Gain 100 dB
- Wide Bandwidth (Unity Gain) 1 MHz (Temperature Compensated)
- Wide Power Supply Range:
  - Single Supply 3V to 32V
  - Or Dual Supplies  $\pm 1.5V$  to  $\pm 16V$
- Very Low Supply Current Drain (700  $\mu A$ ) — Essentially Independent of Supply Voltage
- Low Input Biasing Current 45 nA (Temperature Compensated)
- Low Input Offset Voltage 2 mV and Offset Current: 5 nA
- Input Common-Mode Voltage Range Includes Ground
- Differential Input Voltage Range Equal to the

### Power Supply Voltage

- Large Output Voltage Swing 0V to  $V^+ - 1.5V$

### DESCRIPTION

The LM124/124A consists of four independent, high gain, internally frequency compensated operational amplifiers which were designed specifically to operate from a single power supply over a wide range of voltages. Operation from split power supplies is also possible and the low power supply current drain is independent of the magnitude of the power supply voltage.

Application areas include transducer amplifiers, DC gain blocks and all the conventional op amp circuits which now can be more easily implemented in single power supply systems. For example, the LM124/124A can be directly operated off of the standard +5Vdc power supply voltage which is used in digital systems and will easily provide the required interface electronics without requiring the additional +15Vdc power supplies.

### Unique Characteristics

- In the Linear Mode, the Input Common-Mode Voltage Range Includes Ground and the Output Voltage can also Swing to Ground, even though Operated from Only a Single Power Supply Voltage
- The Unity Gain Cross Frequency is Temperature Compensated
- The Input Bias Current is also Temperature Compensated

### Advantages

- Eliminates Need for Dual Supplies
- Four Internally Compensated Op Amps in a Single Package
- Allows Directly Sensing near GND and  $V_{OUT}$  also Goes to GND
- Compatible with all Forms of Logic
- Power Drain Suitable for Battery Operation



Please be aware that an important notice concerning availability, standard warranty, and use in critical applications of Texas Instruments semiconductor products and disclaimers thereto appears at the end of this data sheet.

All trademarks are the property of their respective owners.



These devices have limited built-in ESD protection. The leads should be shorted together or the device placed in conductive foam during storage or handling to prevent electrostatic damage to the MOS gates.

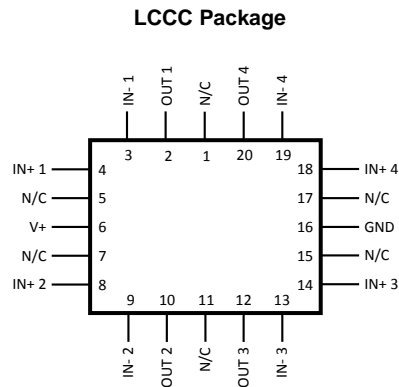

**Figure 1. Package Number NAJ0020A**

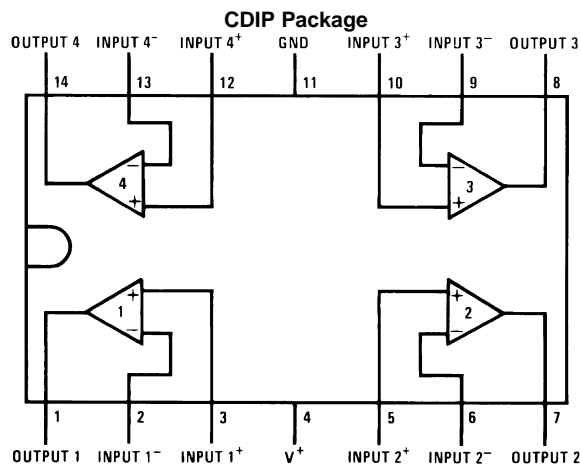

**Figure 2. Top View  
Package Number J0014A**

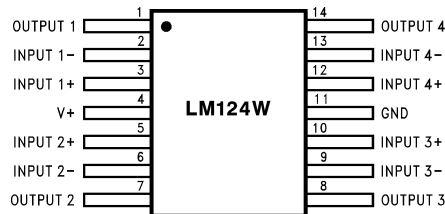

**Figure 3. Package Number NAD0014B or NAC0014A**

### Schematic Diagram

(Each Amplifier)

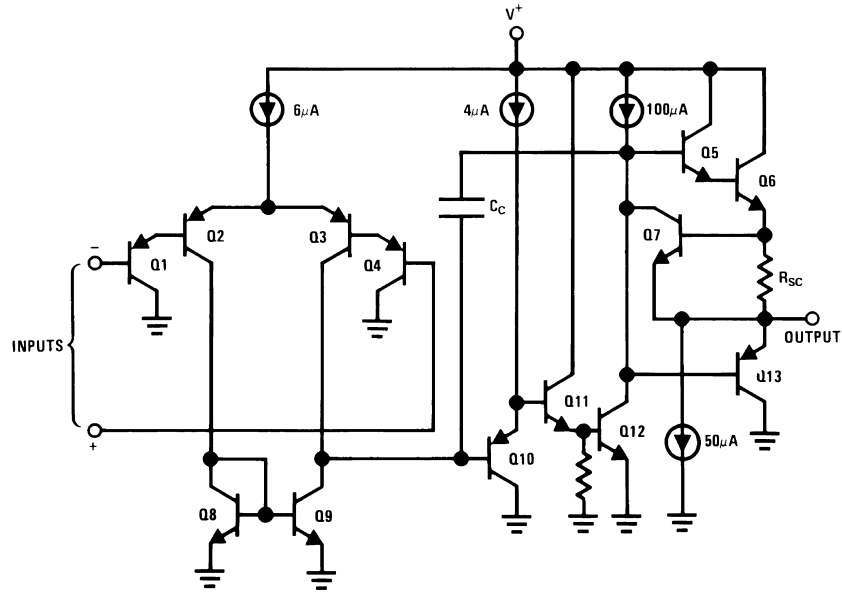

**Absolute Maximum Ratings** <sup>(1)</sup>

Supply Voltage, V <sup>+</sup>	32Vdc or ±16Vdc
Differential Input Voltage	32Vdc
Input Voltage	–0.3Vdc to +32Vdc
Input Current (V <sub>IN</sub> < –0.3Vdc) <sup>(2)</sup>	50 mA
Power Dissipation <sup>(3)</sup>	
CDIP	1260mW
CLGA	700mW
LCCC	1350mW
CLGA	700mW
Output Short-Circuit to GND (One Amplifier) <sup>(4)</sup> V <sup>+</sup> ≤ 15Vdc and T <sub>A</sub> = 25°C	Continuous
Operating Temperature Range	–55°C ≤ T <sub>A</sub> ≤ +125°C
Maximum Junction Temperature	150°C
Storage Temperature Range	–65°C ≤ T <sub>A</sub> ≤ +150°C
Lead Temperature (Soldering, 10 seconds)	260°C
Thermal Resistance ThetaJA	
<b>CDIP</b> (Still Air) (500LF/Min Air flow)	103°C/W 51°C/W
<b>CLGA</b> (Still Air) (500LF/Min Air flow)	176°C/W 116°C/W
<b>LCCC</b> (Still Air) (500LF/Min Air flow)	91°C/W 66°C/W
<b>CLGA</b> (Still Air) (500LF/Min Air flow)	176°C/W 116°C/W
ThetaJC	
CDIP	19°C/W
CLGA	18°C/W
LCCC	24°C/W
CLGA	18°C/W
Package Weight (Typical)	
CDIP	2200mg
CLGA	460mg
LCCC	470mg
CLGA	410mg
ESD Tolerance <sup>(5)</sup>	250V

- (1) Absolute Maximum Ratings indicate limits beyond which damage to the device may occur. Operating Ratings indicate conditions for which the device is functional, but do not ensure specific performance limits. For ensured specifications and test conditions, see the Electrical Characteristics. The ensured specifications apply only for the test conditions listed. Some performance characteristics may degrade when the device is not operated under the listed test conditions.
- (2) This input current will only exist when the voltage at any of the input leads is driven negative. It is due to the collector-base junction of the input PNP transistors becoming forward biased and thereby acting as input diode clamps. In addition to this diode action, there is also lateral NPN parasitic transistor action on the IC chip. This transistor action can cause the output voltages of the op amps to go to the V<sup>+</sup> voltage level (or to ground for a large overdrive) for the time duration that an input is driven negative. This is not destructive and normal output states will re-establish when the input voltage, which was negative, again returns to a value greater than –0.3V<sub>DC</sub> (at 25°C).
- (3) The maximum power dissipation must be derated at elevated temperatures and is dictated by T<sub>Jmax</sub> (maximum junction temperature), ThetaJA (package junction to ambient thermal resistance), and T<sub>A</sub> (ambient temperature). The maximum allowable power dissipation at any temperature is P<sub>Dmax</sub> = (T<sub>Jmax</sub> – T<sub>A</sub>)/ThetaJA or the number given in the Absolute Maximum Ratings, whichever is lower.
- (4) Short circuits from the output to V<sup>+</sup> can cause excessive heating and eventual destruction. When considering short circuits to ground, the maximum output current is approximately 40mA independent of the magnitude of V<sup>+</sup>. At values of supply voltage in excess of +15V<sub>DC</sub>, continuous short-circuits can exceed the power dissipation ratings and cause eventual destruction. Destructive dissipation can result from simultaneous shorts on all amplifiers.
- (5) Human body model, 1.5 kΩ in series with 100 pF.

**Quality Conformance Inspection**

MIL-STD-883, Method 5005 - Group A

<b>Subgroup</b>	<b>Description</b>	<b>Temp ( °C)</b>
1	Static tests at	+25
2	Static tests at	+125
3	Static tests at	-55
4	Dynamic tests at	+25
5	Dynamic tests at	+125
6	Dynamic tests at	-55
7	Functional tests at	+25
8A	Functional tests at	+125
8B	Functional tests at	-55
9	Switching tests at	+25
10	Switching tests at	+125
11	Switching tests at	-55

## LM124/883 Electrical Characteristics SMD: 77043 DC Parameters

(The following conditions apply to all the following parameters, unless otherwise specified.)

**All voltages referenced to device ground.**

Symbol	Parameter	Conditions	Notes	Min	Max	Unit	Sub-Groups
$I_{CC}$	Power Supply Current	$V_+ = 5V$			1.2	mA	1, 2, 3
		$V_+ = 30V$			3.0	mA	1
					4.0	mA	2, 3
$I_{SINK}$	Output Sink Current	$V_+ = 15V, V_{OUT} = 200mV, +V_{IN} = 0mV, -V_{IN} = +65mV$		12		$\mu A$	1
		$V_+ = 15V, V_{OUT} = 2V, +V_{IN} = 0mV, -V_{IN} = +65mV$		10		mA	1
				5		mA	2, 3
$I_{SOURCE}$	Output Source Current	$V_+ = 15V, V_{OUT} = 2V, +V_{IN} = 0mV, -V_{IN} = -65mV$			-20	mA	1
					-10	mA	2, 3
$I_{OS}$	Short Circuit Current	$V_+ = 5V, V_{OUT} = 0V$		-60		mA	1
$V_{IO}$	Input Offset Voltage	$V_+ = 30V, V_{CM} = 0V$		-5	5	mV	1
				-7	7	mV	2, 3
		$V_+ = 30V, V_{CM} = 28V$		-5	5	mV	1
				-7	7	mV	2, 3
		$V_+ = 5V, V_{CM} = 0V$		-5	5	mV	1
				-7	7	mV	2, 3
$V_{CM}$	Common Mode Voltage Range	$V_+ = 30V$	(3)		28.5	V	1
			(1)		28	V	2, 3
$A_{VS}$	Large Signal Gain	$V_+ = 15V, R_L = 2K \Omega, V_O = 1V \text{ to } 11V$		50		V/mV	4
				25		V/mV	5, 6
$V_{OH}$	Output Voltage High	$V_+ = 30V, R_L = 2K \Omega$		26		V	4, 5, 6
		$V_+ = 30V, R_L = 10K \Omega$		27		V	4, 5, 6
$V_{OL}$	Output Voltage Low	$V_+ = 30V, R_L = 10K \Omega$			40	mV	4, 5, 6
		$V_+ = 30V, I_{SINK} = 1\mu A$			40	mV	4
					100	mV	5, 6
		$V_+ = 5V, R_L = 10K \Omega$			20	mV	4, 5, 6
	Channel Separation (Amp to Amp Coupling)	1KHz, 20KHz	(4) (5)	80		dB	4

- (1) The input common-mode voltage of either input signal voltage should not be allowed to go negative by more than 0.3V (at 25°C). The upper end of the common-mode voltage range is  $V_+ - 1.5V$  (at 25°C), but either or both inputs can go to +32V without damage independent of the magnitude of  $V_+$ .
- (2) The direction of the input current is out of the IC due to the PNP input stage. This current is essentially constant, independent of the state of the output so no loading change exists on the input lines.
- (3) Specified by  $V_{IO}$  tests.
- (4) Ensured, not tested
- (5) Due to proximity of external components, insure that coupling is not originating via stray capacitance between these external parts. This typically can be detected as this type of capacitance increases at higher frequencies.

**LM124A/883 Electrical Characteristics SMD: 77043 DC Parameters**

(The following conditions apply to all the following parameters, unless otherwise specified.)

**All voltages referenced to device ground.**

Symbol	Parameter	Conditions	Notes	Min	Max	Unit	Sub-Groups
I <sub>CC</sub>	Power Supply Current	V <sub>+</sub> = 5V			1.2	mA	1, 2, 3
		V <sub>+</sub> = 30V			3.0	mA	1
					4.0	mA	2, 3
I <sub>SINK</sub>	Output Sink Current	V <sub>+</sub> = 15V, V <sub>OUT</sub> = 200mV, +V <sub>IN</sub> = 0mV, -V <sub>IN</sub> = +65mV		12		uA	1
		V <sub>+</sub> = 15V, V <sub>OUT</sub> = 2V, +V <sub>IN</sub> = 0mV, -V <sub>IN</sub> = +65mV		10		mA	1
				5		mA	2, 3
I <sub>SOURCE</sub>	Output Source Current	V <sub>+</sub> = 15V, V <sub>OUT</sub> = 2V, +V <sub>IN</sub> = 0mV, -V <sub>IN</sub> = -65mV			-20	mA	1
					-10	mA	2, 3
I <sub>OS</sub>	Short Circuit Current	V <sub>+</sub> = 5V, V <sub>OUT</sub> = 0V		-60		mA	1
V <sub>IO</sub>	Input Offset Voltage	V <sub>+</sub> = 30V, V <sub>CM</sub> = 0V		-2	2	mV	1
				-4	4	mV	2, 3
		V <sub>+</sub> = 30V, V <sub>CM</sub> = 28.5V		-2	2	mV	1
		V <sub>+</sub> = 30V, V <sub>CM</sub> = 28V		-4	4	mV	2, 3
		V <sub>+</sub> = 5V, V <sub>CM</sub> = 0V		-2	2	mV	1
	-4		4	mV	2, 3		
CMRR	Common Mode Rejection Ratio	V <sub>+</sub> = 30V, V <sub>IN</sub> = 0V to 28.5V	(1)	70		dB	1
±I <sub>B</sub>	Input Bias Current	V <sub>+</sub> = 5V, V <sub>CM</sub> = 0V	(2)	-50	10	nA	1
				-100	10	nA	2, 3
I <sub>IO</sub>	Input Offset Current	V <sub>+</sub> = 5V, V <sub>CM</sub> = 0V		-10	10	nA	1
				-30	30	nA	2, 3
PSRR	Power Supply Rejection Ratio	V <sub>+</sub> = 5V to 30V, V <sub>CM</sub> = 0V		65		dB	1
V <sub>CM</sub>	Common Mode Voltage Range	V <sub>+</sub> = 30V	(3) (1)		28.5	V	1
					28	V	2, 3
A <sub>VS</sub>	Large Signal Gain	V <sub>+</sub> = 15V, R <sub>L</sub> = 2K Ω, V <sub>O</sub> = 1V to 11V	(4)	50		V/mV	4
				25		V/mV	5, 6
V <sub>OH</sub>	Output Voltage High	V <sub>+</sub> = 30V, R <sub>L</sub> = 2K Ω		26		V	4, 5, 6
		V <sub>+</sub> = 30V, R <sub>L</sub> = 10K Ω		27		V	4, 5, 6
V <sub>OL</sub>	Output Voltage Low	V <sub>+</sub> = 30V, R <sub>L</sub> = 10K Ω			40	mV	4, 5, 6
		V <sub>+</sub> = 30V, I <sub>SINK</sub> = 1uA			40	mV	4
					100	mV	5, 6
		V <sub>+</sub> = 5V, R <sub>L</sub> = 10K Ω			20	mV	4, 5, 6
	Channel Separation Amp to Amp Coupling	1KHz, 20KHz	(5) (6)	80		dB	4

- (1) The input common-mode voltage of either input signal voltage should not be allowed to go negative by more than 0.3V (at 25°C). The upper end of the common-mode voltage range is V<sub>+</sub> -1.5V (at 25°C), but either or both inputs can go to +32V without damage independent of the magnitude of V<sub>+</sub>.
- (2) The direction of the input current is out of the IC due to the PNP input stage. This current is essentially constant, independent of the state of the output so no loading change exists on the input lines.
- (3) Specified by V<sub>IO</sub> tests.
- (4) Datalog reading in K=V/mV
- (5) Ensured, not tested
- (6) Due to proximity of external components, insure that coupling is not originating via stray capacitance between these external parts. This typically can be detected as this type of capacitance increases at higher frequencies.

**LM124A RAD HARD Electrical Characteristics SMD: 5962R99504 DC Parameters<sup>(1) (2)</sup>**

(The following conditions apply to all the following parameters, unless otherwise specified.)

**All voltages referenced to device ground.**

Symbol	Parameter	Conditions	Notes	Min	Max	Unit	Sub-Groups
V <sub>IO</sub>	Input Offset Voltage	V <sub>CC+</sub> = 30V, V <sub>CC-</sub> = Gnd, V <sub>CM</sub> = +15V		-2	2	mV	1
				-4	4	mV	2, 3
		V <sub>CC+</sub> = 2V, V <sub>CC-</sub> = -28V, V <sub>CM</sub> = -13V		-2	2	mV	1
				-4	4	mV	2, 3
		V <sub>CC+</sub> = 5V, V <sub>CC-</sub> = Gnd, V <sub>CM</sub> = +1.4V		-2	2	mV	1
				-4	4	mV	2, 3
		V <sub>CC+</sub> = 2.5V, V <sub>CC-</sub> = -2.5, V <sub>CM</sub> = -1.1V		-2	2	mV	1
				-4	4	mV	2, 3
I <sub>IO</sub>	Input Offset Current	V <sub>CC+</sub> = 30V, V <sub>CC-</sub> = Gnd, V <sub>CM</sub> = +15V		-10	10	nA	1, 2
				-30	30	nA	3
		V <sub>CC+</sub> = 2V, V <sub>CC-</sub> = -28V, V <sub>CM</sub> = -13V		-10	10	nA	1, 2
				-30	30	nA	3
		V <sub>CC+</sub> = 5V, V <sub>CC-</sub> = Gnd, V <sub>CM</sub> = +1.4V		-10	10	nA	1, 2
				-30	30	nA	3
		V <sub>CC+</sub> = 2.5V, V <sub>CC-</sub> = -2.5, V <sub>CM</sub> = -1.1V		-10	10	nA	1, 2
				-30	30	nA	3
±I <sub>B</sub>	Input Bias Current	V <sub>CC+</sub> = 30V, V <sub>CC-</sub> = Gnd, V <sub>CM</sub> = +15V	(3)	-50	+0.1	nA	1, 2
				-100	+0.1	nA	3
		V <sub>CC+</sub> = 2V, V <sub>CC-</sub> = -28V, V <sub>CM</sub> = -13V		-50	+0.1	nA	1, 2
				-100	+0.1	nA	3
		V <sub>CC+</sub> = 5V, V <sub>CC-</sub> = Gnd, V <sub>CM</sub> = +1.4V		-50	+0.1	nA	1, 2
		-100	+0.1	nA	3		
		V <sub>CC+</sub> = 2.5V, V <sub>CC-</sub> = -2.5, V <sub>CM</sub> = -1.1V		-50	+0.1	nA	1, 2
				-100	+0.1	nA	3
+PSRR	Power Supply Rejection Ratio	V <sub>CC-</sub> = Gnd, V <sub>CM</sub> = +1.4V, 5V ≤ V <sub>CC+</sub> ≤ 30V		-100	100	uV/V	1, 2, 3
CMRR	Common Mode Rejection Ratio		(4)	76		dB	1, 2, 3
I <sub>OS+</sub>	Output Short Circuit Current	V <sub>CC+</sub> = 30V, V <sub>CC-</sub> = Gnd, V <sub>O</sub> = 25V		-70		mA	1, 2,3
I <sub>CC</sub>	Power Supply Current	V <sub>CC+</sub> = 30V, V <sub>CC-</sub> = Gnd			3	mA	1, 2
					4	mA	3
ΔV <sub>IO</sub> / ΔT	Input Offset Voltage Temperature Sensitivity	+25°C ≤ T <sub>A</sub> ≤ +125°C, +V <sub>CC</sub> = 5V, -V <sub>CC</sub> = 0V, V <sub>CM</sub> = +1.4V	(5)	-30	30	uV/ °C	2
		-55°C ≤ T <sub>A</sub> ≤ +25°C, +V <sub>CC</sub> = 5V, -V <sub>CC</sub> = 0V, V <sub>CM</sub> = +1.4V		-30	30	uV/ °C	3

- (1) Pre and post irradiation limits are identical to those listed under AC and DC electrical characteristics except as listed in the Post Radiation Limits Table. These parts may be dose rate sensitive in a space environment and demonstrate enhanced low dose rate effect. Radiation end point limits for the noted parameters are ensured only for the conditions as specified in MIL-STD-883, Method 1019
- (2) Low dose rate testing has been performed on a wafer-by-wafer basis, per test method 1019 condition D of MIL-STD-883, with no enhanced low dose rate sensitivity (ELDRS) effect.
- (3) The direction of the input current is out of the IC due to the PNP input stage. This current is essentially constant, independent of the state of the output so no loading change exists on the input lines.
- (4) The input common-mode voltage of either input signal voltage should not be allowed to go negative by more than 0.3V (at 25°C). The upper end of the common-mode voltage range is V<sub>+</sub> -1.5V (at 25°C), but either or both inputs can go to +32V without damage independent of the magnitude of V<sub>+</sub>.
- (5) Calculated parameters



**LM124A RAD HARD Electrical Characteristics SMD: 5962R99504 DC Parameters<sup>(1) (2)</sup>**  
**(continued)**

(The following conditions apply to all the following parameters, unless otherwise specified.)

**All voltages referenced to device ground.**

Symbol	Parameter	Conditions	Notes	Min	Max	Unit	Sub-Groups
$\Delta I_O / \Delta T$	Input Offset Current Temperature Sensitivity	$+25^\circ\text{C} \leq T_A \leq +125^\circ\text{C}$ , $+V_{CC} = 5\text{V}$ , $-V_{CC} = 0\text{V}$ , $V_{CM} = +1.4\text{V}$	(5)	-400	400	pA/°C	2
		$-55^\circ\text{C} \leq T_A \leq +25^\circ\text{C}$ , $+V_{CC} = 5\text{V}$ , $-V_{CC} = 0\text{V}$ , $V_{CM} = +1.4\text{V}$		-700	700	pA/°C	3

**LM124A RAD HARD SMD: 5962R99504 AC/DC Parameters<sup>(1) (2)</sup>**

(The following conditions apply to all the following parameters, unless otherwise specified.)

**All voltages referenced to device ground.**

Symbol	Parameter	Conditions	Notes	Min	Max	Unit	Sub-Groups
$V_{OL}$	Logical "0" Output Voltage	$V_{CC+} = 30\text{V}$ , $V_{CC-} = \text{Gnd}$ , $R_L = 10\text{K } \Omega$			35	mV	4, 5, 6
		$V_{CC+} = 30\text{V}$ , $V_{CC-} = \text{Gnd}$ , $I_{OI} = 5\text{mA}$			1.5	V	4, 5, 6
		$V_{CC+} = 4.5\text{V}$ , $V_{CC-} = \text{Gnd}$ , $I_{OI} = 2\mu\text{A}$			0.4	V	4, 5, 6
$V_{OH}$	Logical "1" Output Voltage	$V_{CC+} = 30\text{V}$ , $V_{CC-} = \text{Gnd}$ , $I_{OH} = -10\text{mA}$		27		V	4, 5, 6
		$V_{CC+} = 4.5\text{V}$ , $V_{CC-} = \text{Gnd}$ , $I_{OH} = -10\text{mA}$		2.4		V	4, 5, 6
$A_{VS+}$	Voltage Gain	$V_{CC+} = 30\text{V}$ , $V_{CC-} = \text{Gnd}$ , $1\text{V} \leq V_O \leq 26\text{V}$ , $R_L = 10\text{K } \Omega$		50		V/mV	4
				25		V/mV	5, 6
		$V_{CC+} = 30\text{V}$ , $V_{CC-} = \text{Gnd}$ , $5\text{V} \leq V_O \leq 20\text{V}$ , $R_L = 2\text{K } \Omega$		50		V/mV	4
				25		V/mV	5, 6
$A_{VS}$	Voltage Gain	$V_{CC+} = 5\text{V}$ , $V_{CC-} = \text{Gnd}$ , $1\text{V} \leq V_O \leq 2.5\text{V}$ , $R_L = 10\text{K } \Omega$		10		V/mV	4, 5, 6
		$V_{CC+} = 5\text{V}$ , $V_{CC-} = \text{Gnd}$ , $1\text{V} \leq V_O \leq 2.5\text{V}$ , $R_L = 2\text{K } \Omega$		10		V/mV	4, 5, 6
$+V_{OP}$	Maximum Output Voltage Swing	$V_{CC+} = 30\text{V}$ , $V_{CC-} = \text{Gnd}$ , $V_O = +30\text{V}$ , $R_L = 10\text{K } \Omega$		27		V	4, 5, 6
		$V_{CC+} = 30\text{V}$ , $V_{CC-} = \text{Gnd}$ , $V_O = +30\text{V}$ , $R_L = 2\text{K } \Omega$		26		V	4, 5, 6
$TR_{(TR)}$	Transient Response: Rise Time	$V_{CC+} = 30\text{V}$ , $V_{CC-} = \text{Gnd}$			1	$\mu\text{S}$	7, 8A, 8B
$TR_{(OS)}$	Transient Response: Overshoot	$V_{CC+} = 30\text{V}$ , $V_{CC-} = \text{Gnd}$			50	%	7, 8A, 8B
$\pm S_R$	Slew Rate: Rise	$V_{CC+} = 30\text{V}$ , $V_{CC-} = \text{Gnd}$		0.1		V/ $\mu\text{S}$	7, 8A, 8B
	Slew Rate: Fall	$V_{CC+} = 30\text{V}$ , $V_{CC-} = \text{Gnd}$		0.1		V/ $\mu\text{S}$	7, 8A, 8B

- (1) Pre and post irradiation limits are identical to those listed under AC and DC electrical characteristics except as listed in the Post Radiation Limits Table. These parts may be dose rate sensitive in a space environment and demonstrate enhanced low dose rate effect. Radiation end point limits for the noted parameters are ensured only for the conditions as specified in MIL-STD-883, Method 1019
- (2) Low dose rate testing has been performed on a wafer-by-wafer basis, per test method 1019 condition D of MIL-STD-883, with no enhanced low dose rate sensitivity (ELDRS) effect.

**LM124A RAD HARD SMD: 5962R99504 AC Parameters<sup>(1) (2)</sup>**

(The following conditions apply to all the following parameters, unless otherwise specified.)

**AC: +V<sub>CC</sub> = 30V, -V<sub>CC</sub> = 0V**

Symbol	Parameter	Conditions	Notes	Min	Max	Unit	Sub-Groups
N <sub>lBB</sub>	Noise Broadband	+V <sub>CC</sub> = 15V, -V <sub>CC</sub> = -15V, BW = 10Hz to 5KHz			15	uVrm s	7
N <sub>lPC</sub>	Noise Popcorn	+V <sub>CC</sub> = 15V, -V <sub>CC</sub> = -15V, R <sub>S</sub> = 20K Ω, BW = 10Hz to 5KHz			50	uVpK	7
C <sub>S</sub>	Channel Separation	+V <sub>CC</sub> = 30V, -V <sub>CC</sub> = Gnd, R <sub>L</sub> = 2K Ω	(3)	80		dB	7
		R <sub>L</sub> = 2K Ω, V <sub>IN</sub> = 1V and 16V, A to B		80		dB	7
		R <sub>L</sub> = 2K Ω, V <sub>IN</sub> = 1V and 16V, A to C		80		dB	7
		R <sub>L</sub> = 2K Ω, V <sub>IN</sub> = 1V and 16V, A to D		80		dB	7
		R <sub>L</sub> = 2K Ω, V <sub>IN</sub> = 1V and 16V, B to A		80		dB	7
		R <sub>L</sub> = 2K Ω, V <sub>IN</sub> = 1V and 16V, B to C		80		dB	7
		R <sub>L</sub> = 2K Ω, V <sub>IN</sub> = 1V and 16V, B to D		80		dB	7
		R <sub>L</sub> = 2K Ω, V <sub>IN</sub> = 1V and 16V, C to A		80		dB	7
		R <sub>L</sub> = 2K Ω, V <sub>IN</sub> = 1V and 16V, C to B		80		dB	7
		R <sub>L</sub> = 2K Ω, V <sub>IN</sub> = 1V and 16V, C to D		80		dB	7
		R <sub>L</sub> = 2K Ω, V <sub>IN</sub> = 1V and 16V, D to A		80		dB	7
		R <sub>L</sub> = 2K Ohms, V <sub>IN</sub> = 1V and 16V, D to B		80		dB	7
R <sub>L</sub> = 2K Ω, V <sub>IN</sub> = 1V and 16V, D to C	80		dB	7			

- (1) Pre and post irradiation limits are identical to those listed under AC and DC electrical characteristics except as listed in the Post Radiation Limits Table. These parts may be dose rate sensitive in a space environment and demonstrate enhanced low dose rate effect. Radiation end point limits for the noted parameters are ensured only for the conditions as specified in MIL-STD-883, Method 1019
- (2) Low dose rate testing has been performed on a wafer-by-wafer basis, per test method 1019 condition D of MIL-STD-883, with no enhanced low dose rate sensitivity (ELDRS) effect.
- (3) Due to proximity of external components, insure that coupling is not originating via stray capacitance between these external parts. This typically can be detected as this type of capacitance increases at higher frequencies.

**LM124A RAD HARD - DC Drift Values SMD: 5962R99504<sup>(1) (2)</sup>**

(The following conditions apply to all the following parameters, unless otherwise specified.)

**DC: "Delta calculations performed on QMLV devices at group B, subgroup 5 only"**

Symbol	Parameter	Conditions	Notes	Min	Max	Unit	Sub-Groups
V <sub>IO</sub>	Input Offset Voltage	V <sub>CC+</sub> = 30V, V <sub>CC-</sub> = Gnd, V <sub>CM</sub> = +15V		-0.5	0.5	mV	1
±I <sub>B</sub>	Input Bias Current	V <sub>CC+</sub> = 30V, V <sub>CC-</sub> = Gnd, V <sub>CM</sub> = +15V		-10	10	nA	1

- (1) Pre and post irradiation limits are identical to those listed under AC and DC electrical characteristics except as listed in the Post Radiation Limits Table. These parts may be dose rate sensitive in a space environment and demonstrate enhanced low dose rate effect. Radiation end point limits for the noted parameters are ensured only for the conditions as specified in MIL-STD-883, Method 1019
- (2) Low dose rate testing has been performed on a wafer-by-wafer basis, per test method 1019 condition D of MIL-STD-883, with no enhanced low dose rate sensitivity (ELDRS) effect.

**LM124A - POST RADIATION LIMITS +25°C SMD: 5962R99504 (1) (2)**

(The following conditions apply to all the following parameters, unless otherwise specified.)

**All voltages referenced to device ground.**

Symbol	Parameter	Conditions	Notes	Min	Max	Unit	Sub-Groups
$V_{IO}$	Input Offset Voltage	$V_{CC+} = 30V, V_{CC-} = \text{Gnd}, V_{CM} = +15V$	(1)	-2.5	2.5	mV	1
		$V_{CC+} = 2V, V_{CC-} = -28V, V_{CM} = -13V$		-2.5	2.5	mV	1
		$V_{CC+} = 5V, V_{CC-} = \text{Gnd}, V_{CM} = +1.4V$		-2.5	2.5	mV	1
		$V_{CC+} = 2.5V, V_{CC-} = -2.5, V_{CM} = -1.1V$		-2.5	2.5	mV	1
$I_{IO}$	Input Offset Current	$V_{CC+} = 30V, V_{CC-} = \text{Gnd}, V_{CM} = +15V$	(1)	-15	15	nA	1
		$V_{CC+} = 2V, V_{CC-} = -28V, V_{CM} = -13V$		-15	15	nA	1
		$V_{CC+} = 5V, V_{CC-} = \text{Gnd}, V_{CM} = +1.4V$		-15	15	nA	1
		$V_{CC+} = 2.5V, V_{CC-} = -2.5V, V_{CM} = -1.1V$		-15	15	nA	1
$\pm I_{IB}$	Input Bias Current	$V_{CC+} = 30V, V_{CC-} = \text{Gnd}, V_{CM} = +15V$	(1)	-75	+0.1	nA	1
		$V_{CC+} = 2V, V_{CC-} = -28V, V_{CM} = -13V$		-75	+0.1	nA	1
		$V_{CC+} = 5V, V_{CC-} = \text{Gnd}, V_{CM} = +1.4V$		-75	+0.1	nA	1
		$V_{CC+} = 2.5V, V_{CC-} = -2.5V, V_{CM} = -1.1V$		-75	+0.1	nA	1
$A_{VS+}$	Voltage Gain	$V_{CC+} = 30V, V_{CC-} = \text{Gnd}, 1V \leq V_O \leq 26V, R_L = 10K \Omega$	(1)	40		V/mV	4
		$V_{CC+} = 30V, V_{CC-} = \text{Gnd}, 5V \leq V_O \leq 20V, R_L = 2K \Omega$		40		V/mV	4

- (1) Pre and post irradiation limits are identical to those listed under AC and DC electrical characteristics except as listed in the Post Radiation Limits Table. These parts may be dose rate sensitive in a space environment and demonstrate enhanced low dose rate effect. Radiation end point limits for the noted parameters are ensured only for the conditions as specified in MIL-STD-883, Method 1019
- (2) Low dose rate testing has been performed on a wafer-by-wafer basis, per test method 1019 condition D of MIL-STD-883, with no enhanced low dose rate sensitivity (ELDRS) effect.

Typical Performance Characteristics

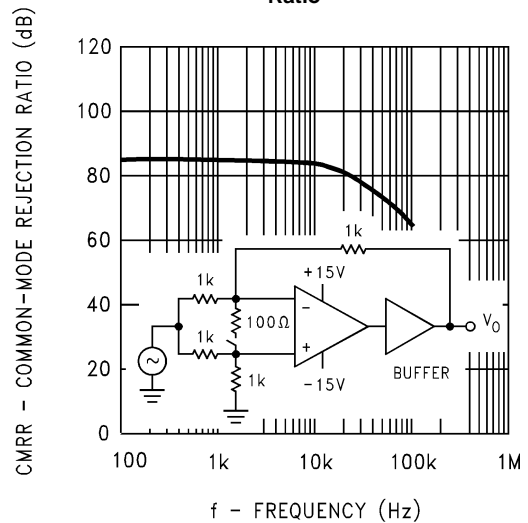
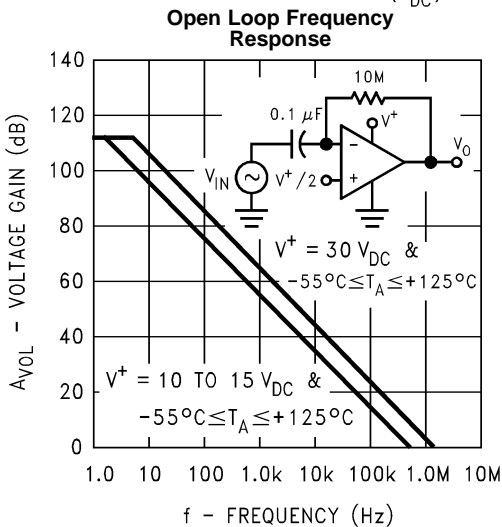
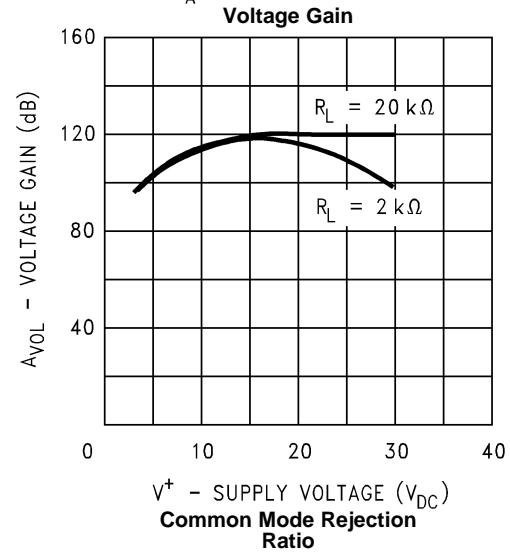
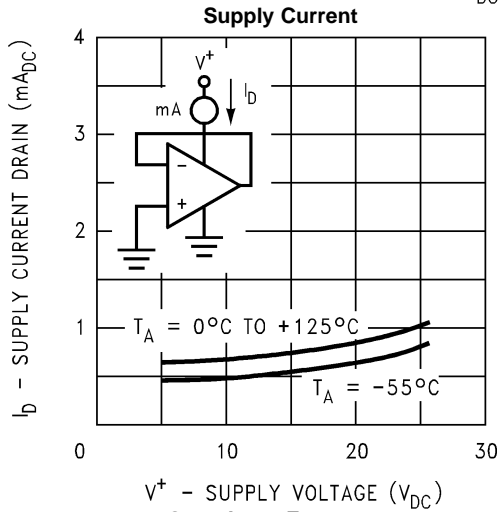
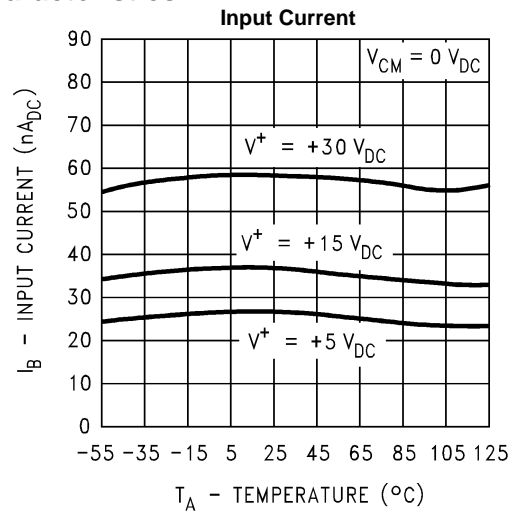
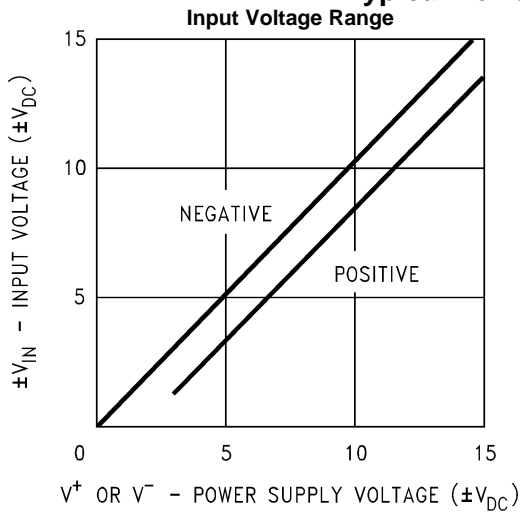

Typical Performance Characteristics (continued)

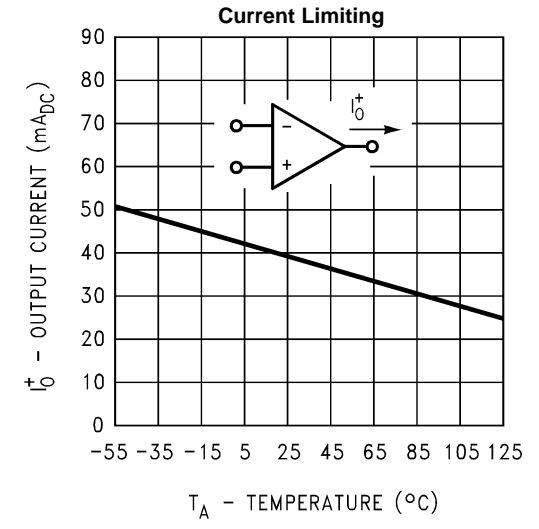
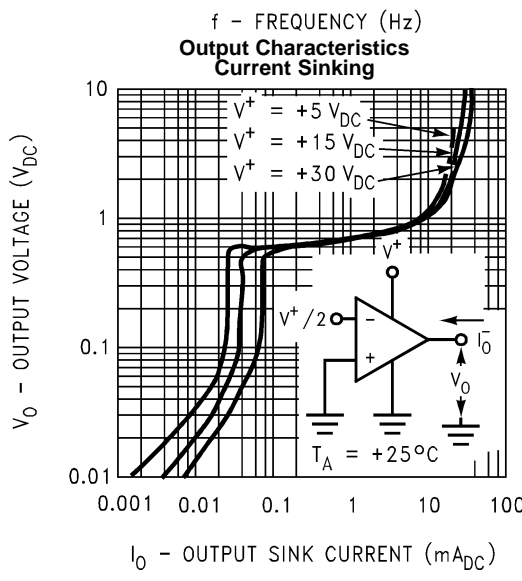
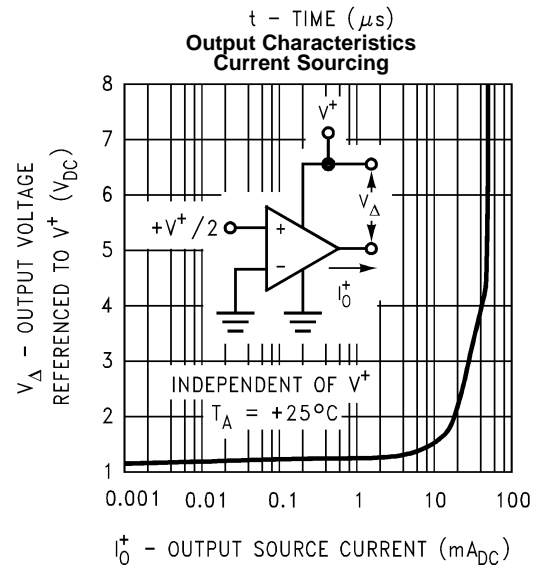
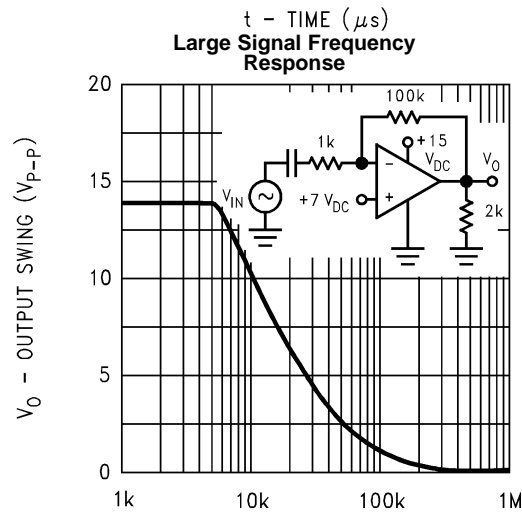
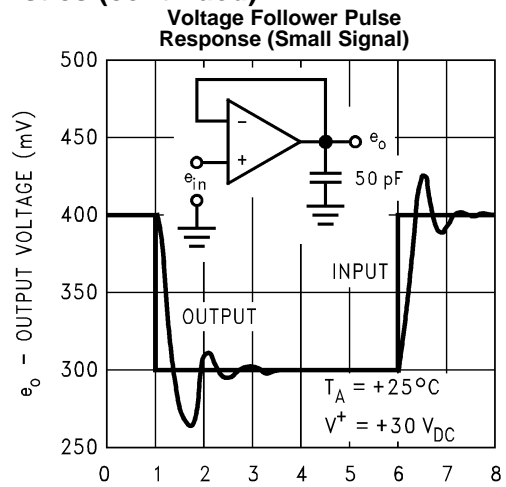
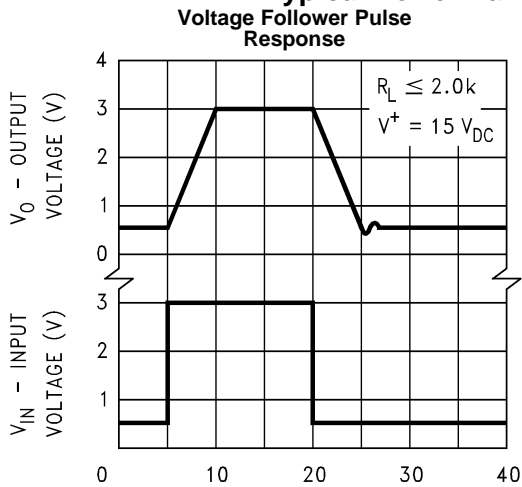

## APPLICATION INFORMATION

### LM124 Series Operational Amplifiers

The LM124 series are op amps which operate with only a single power supply voltage, have true-differential inputs, and remain in the linear mode with an input common-mode voltage of  $0 V_{DC}$ . These amplifiers operate over a wide range of power supply voltage with little change in performance characteristics. At  $25^{\circ}\text{C}$  amplifier operation is possible down to a minimum supply voltage of  $2.3 V_{DC}$ .

The pinouts of the package have been designed to simplify PC board layouts. Inverting inputs are adjacent to outputs for all of the amplifiers and the outputs have also been placed at the corners of the package (pins 1, 7, 8, and 14).

Precautions should be taken to insure that the power supply for the integrated circuit never becomes reversed in polarity or that the unit is not inadvertently installed backwards in a test socket as an unlimited current surge through the resulting forward diode within the IC could cause fusing of the internal conductors and result in a destroyed unit.

Large differential input voltages can be easily accommodated and, as input differential voltage protection diodes are not needed, no large input currents result from large differential input voltages. The differential input voltage may be larger than  $V^+$  without damaging the device. Protection should be provided to prevent the input voltages from going negative more than  $-0.3 V_{DC}$  (at  $25^{\circ}\text{C}$ ). An input clamp diode with a resistor to the IC input terminal can be used.

To reduce the power supply drain, the amplifiers have a class A output stage for small signal levels which converts to class B in a large signal mode. This allows the amplifiers to both source and sink large output currents. Therefore both NPN and PNP external current boost transistors can be used to extend the power capability of the basic amplifiers. The output voltage needs to raise approximately 1 diode drop above ground to bias the on-chip vertical PNP transistor for output current sinking applications.

For ac applications, where the load is capacitively coupled to the output of the amplifier, a resistor should be used, from the output of the amplifier to ground to increase the class A bias current and prevent crossover distortion.

Where the load is directly coupled, as in dc applications, there is no crossover distortion.

Capacitive loads which are applied directly to the output of the amplifier reduce the loop stability margin. Values of 50 pF can be accommodated using the worst-case non-inverting unity gain connection. Large closed loop gains or resistive isolation should be used if larger load capacitance must be driven by the amplifier.

The bias network of the LM124 establishes a drain current which is independent of the magnitude of the power supply voltage over the range of from  $3 V_{DC}$  to  $30 V_{DC}$ .

Output short circuits either to ground or to the positive power supply should be of short time duration. Units can be destroyed, not as a result of the short circuit current causing metal fusing, but rather due to the large increase in IC chip dissipation which will cause eventual failure due to excessive junction temperatures. Putting direct short-circuits on more than one amplifier at a time will increase the total IC power dissipation to destructive levels, if not properly protected with external dissipation limiting resistors in series with the output leads of the amplifiers. The larger value of output source current which is available at  $25^{\circ}\text{C}$  provides a larger output current capability at elevated temperatures (see typical performance characteristics) than a standard IC op amp.

The circuits presented in the section on typical applications emphasize operation on only a single power supply voltage. If complementary power supplies are available, all of the standard op amp circuits can be used. In general, introducing a pseudo-ground (a bias voltage reference of  $V^+/2$ ) will allow operation above and below this value in single power supply systems. Many application circuits are shown which take advantage of the wide input common-mode voltage range which includes ground. In most cases, input biasing is not required and input voltages which range to ground can easily be accommodated.

Typical Single-Supply Applications

(V+ = 5.0 V<sub>DC</sub>)

Non-Inverting DC Gain (0V Input = 0V Output)

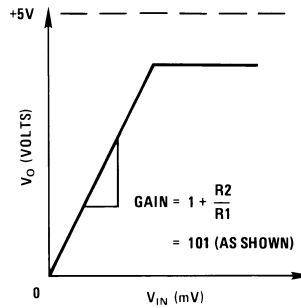
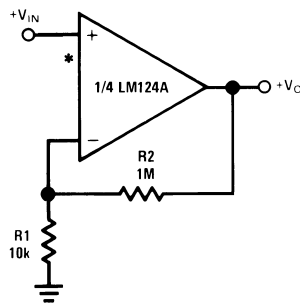

\*R not needed due to temperature independent I<sub>IN</sub>

DC Summing Amplifier (V<sub>IN</sub>'s ≥ 0 V<sub>DC</sub> and V<sub>O</sub> ≥ V<sub>DC</sub>)

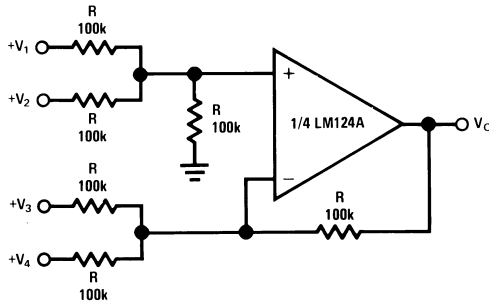

Where:  $V_0 = V_1 + V_2 - V_3 - V_4$   
 $(V_1 + V_2) \geq (V_3 + V_4)$  to keep  $V_0 > 0$  V<sub>DC</sub>

Power Amplifier

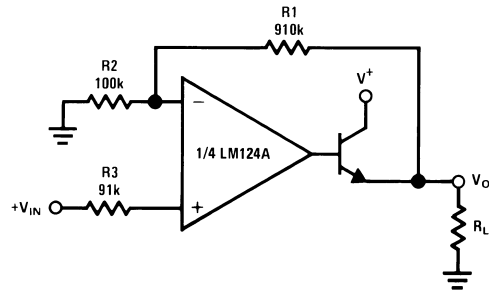

$V_0 = 0$  V<sub>DC</sub> for  $V_{IN} = 0$  V<sub>DC</sub>  
 $A_V = 10$

LED Driver

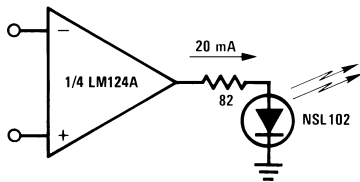

“BI-QUAD” RC Active Bandpass Filter

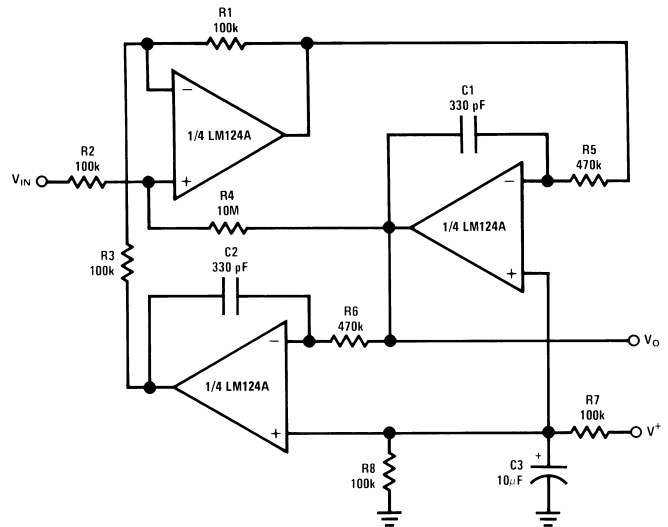

$f_0 = 1$  kHz  
 $Q = 50$   
 $A_V = 100$  (40 dB)

(V<sup>+</sup> = 5.0 V<sub>DC</sub>)

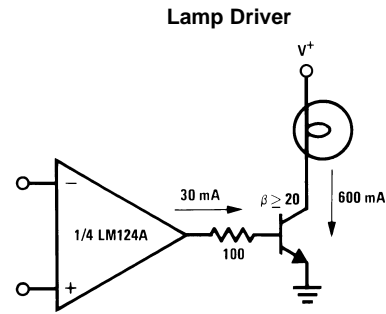
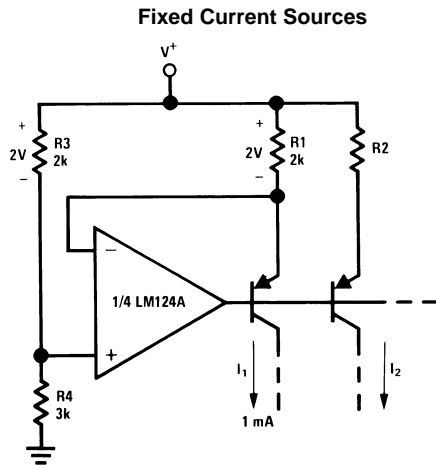

$$I_2 = \left(\frac{R1}{R2}\right) I_1$$

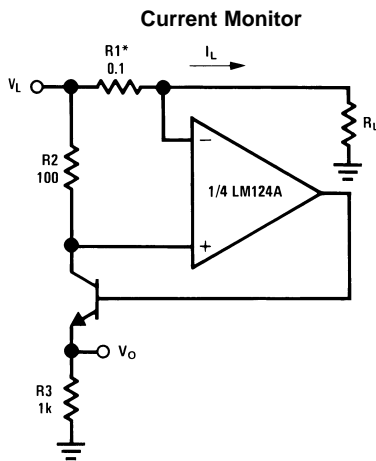

$$V_o = \frac{1V(I_L)}{1A}$$

$$V_L \leq V^+ - 2V$$

\*(Increase R1 for I<sub>L</sub> small)

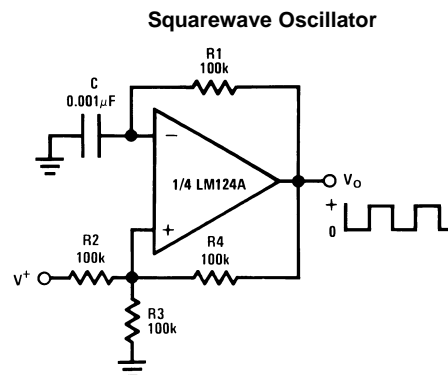
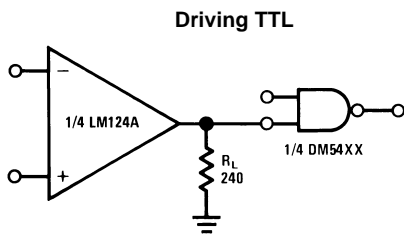
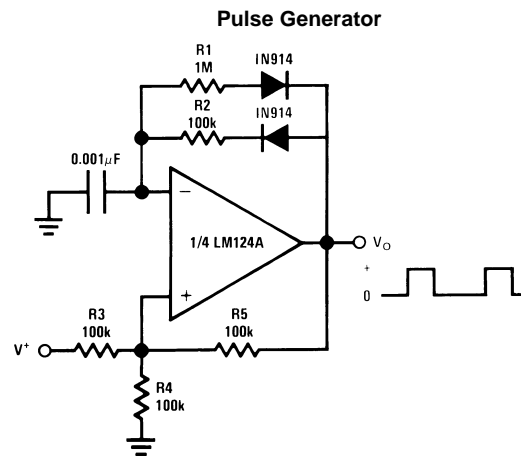



( $V^+ = 5.0 V_{DC}$ )

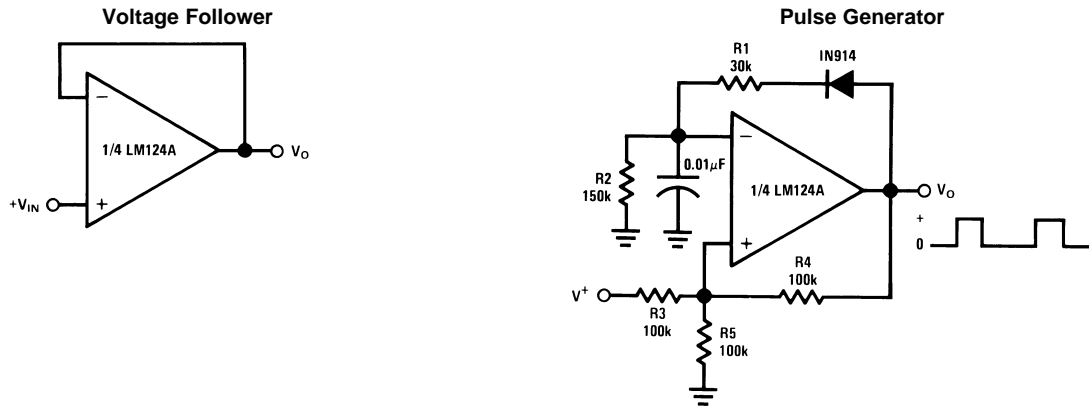

**High Compliance Current Sink**

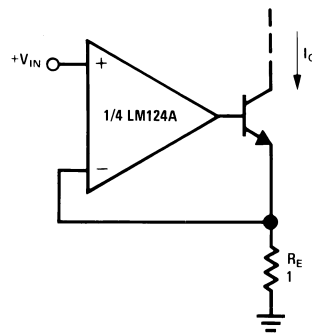

$I_O = 1 \text{ amp/volt } V_{IN}$   
 (Increase  $R_E$  for  $I_O$  small)

**Low Drift Peak Detector**

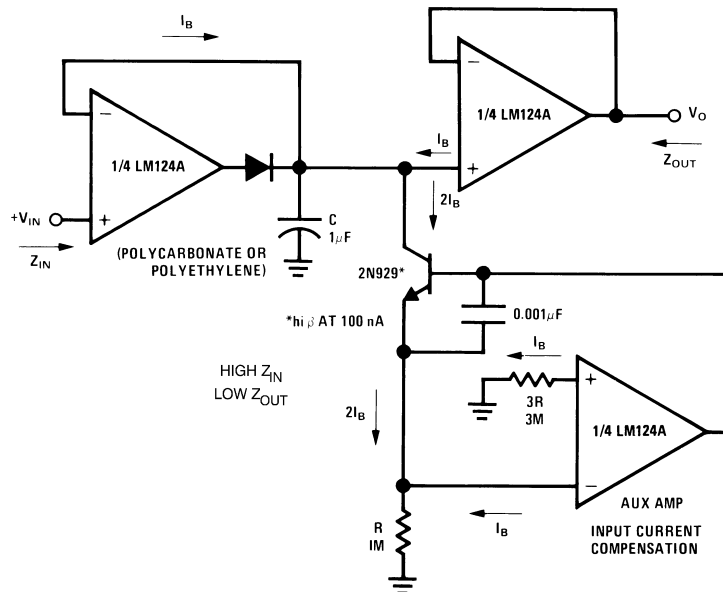

( $V^+ = 5.0 V_{DC}$ )

Comparator with Hysteresis

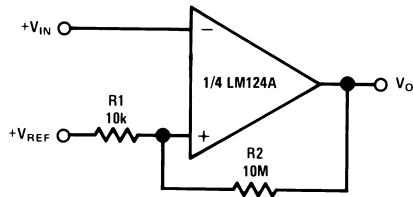

Ground Referencing a Differential Input Signal

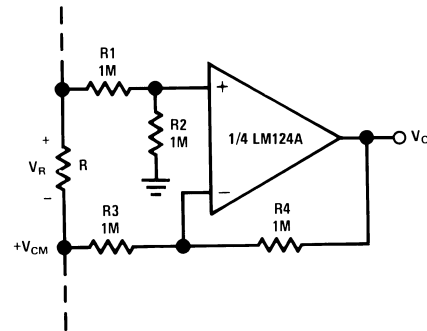

$V_O = V_R$

Voltage Controlled Oscillator Circuit

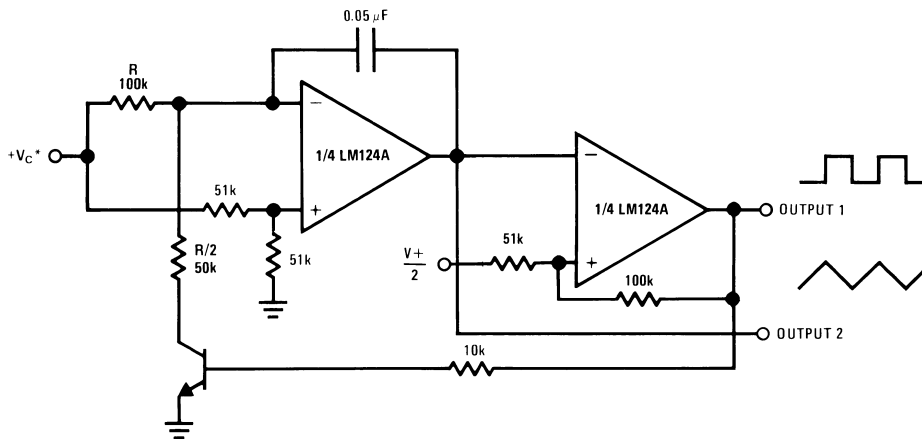

\*Wide control voltage range:  $0 V_{DC} \leq V_C \leq 2 (V^+ - 1.5 V_{DC})$

Photo Voltaic-Cell Amplifier

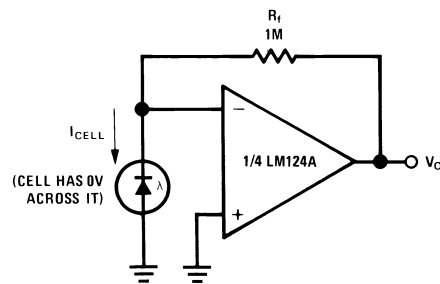

(V<sup>+</sup> = 5.0 V<sub>DC</sub>)

AC Coupled Inverting Amplifier

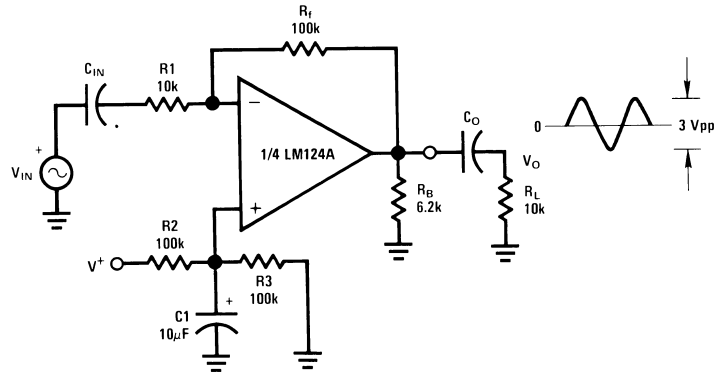

$$A_V = \frac{R_F}{R_1} \text{ (As shown, } A_V = 10 \text{)}$$

AC Coupled Non-Inverting Amplifier

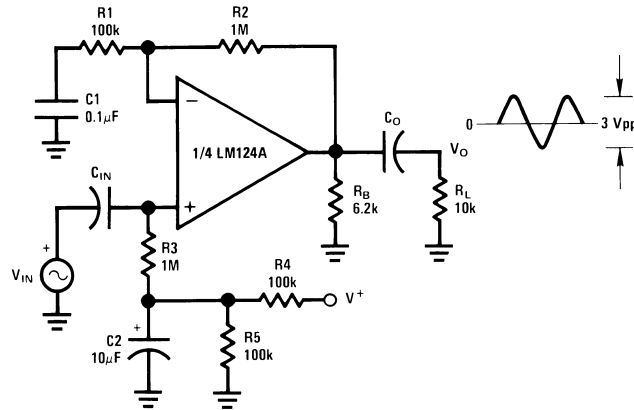

$$A_V = 1 + \frac{R_2}{R_1}$$

A<sub>V</sub> = 11 (As shown)

DC Coupled Low-Pass RC Active Filter

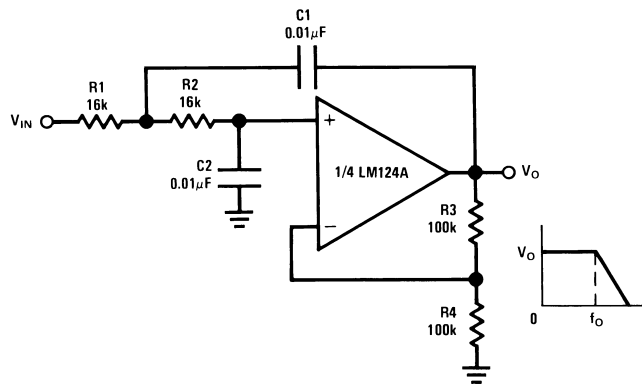

f<sub>o</sub> = 1 kHz  
 Q = 1  
 A<sub>V</sub> = 2

( $V^+ = 5.0 V_{DC}$ )

**High Input Z, DC Differential Amplifier**

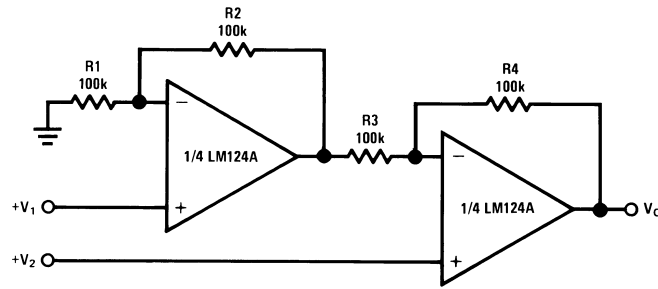

For  $\frac{R1}{R2} = \frac{R4}{R3}$  (CMRR depends on this resistor ratio match)

$$V_O = 1 + \frac{R4}{R3} (V_2 - V_1)$$

As shown:  $V_O = 2(V_2 - V_1)$

**High Input Z Adjustable-Gain DC Instrumentation Amplifier**

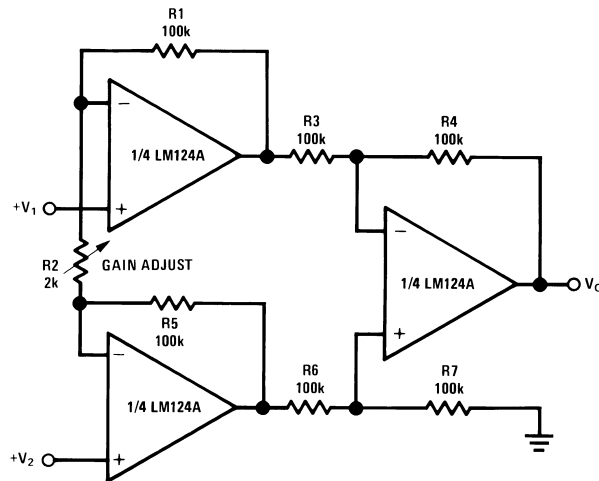

If  $R1 = R5$  &  $R3 = R4 = R6 = R7$  (CMRR depends on match)

$$V_O = 1 + \frac{2R1}{R2} (V_2 - V_1)$$

As shown  $V_O = 101 (V_2 - V_1)$

(V<sup>+</sup> = 5.0 V<sub>DC</sub>)

**Using Symmetrical Amplifiers to Reduce Input Current (General Concept)**

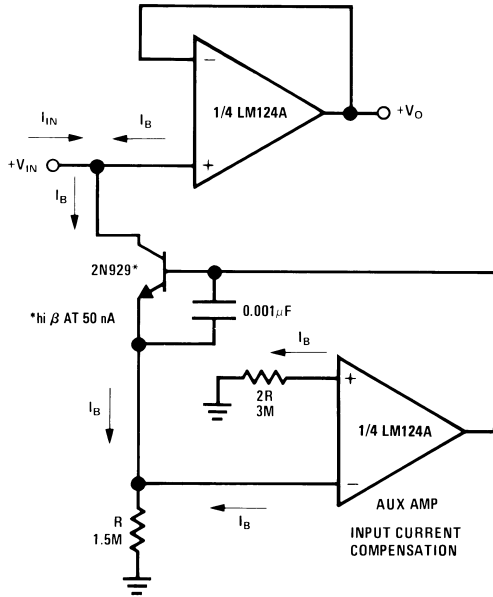

**Bridge Current Amplifier**

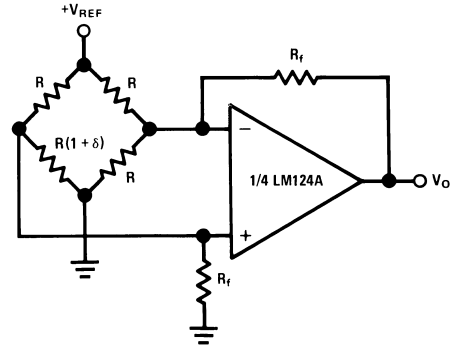

For  $\delta \ll 1$  and  $R_f \gg R$   

$$V_O \approx V_{REF} \left( \frac{\delta}{2} \right) \frac{R_f}{R}$$

**Bandpass Active Filter**

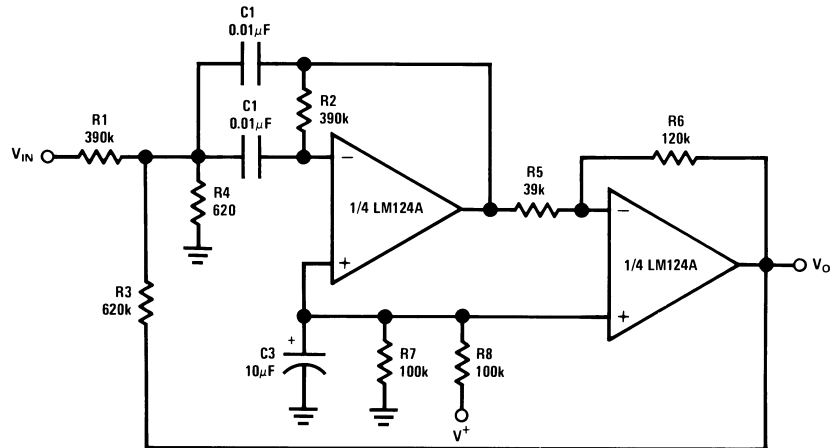

f<sub>O</sub> = 1 kHz  
 Q = 25

## REVISION HISTORY

Date Released	Revision	Section	Changes
9/2/04	A	New Release, Corporate format	3 MDS data sheets converted into one Corp. data sheet format. MNLM124-X, Rev. 1A2, MNLM124A-X, Rev. 1A3 and MRLM124A-X-RH, Rev. 5A0. MDS data sheets will be archived.
01/27/05	B	Connection Diagrams, Quality Conformance Inspection Section, and Physical Dimensions drawings	Added E package Connection Diagram. Changed verbiage under Quality Conformance Title, and Updated Revisions for the Marketing Drawings.
04/18/05	C	Update Absolute Maximum Ratings Section	Corrected typo for Supply Voltage limit From: 32Vdc or +16Vdc TO: 32Vdc or $\pm 16$ Vdc. Added cerpack, cerdip, LCC package weight.
06/16/06	D	Features, Ordering Information Table, Rad Hard Electrical Section and Notes	Added Available with Radiation Specification, Low Dose NSID's to table 5962R9950402VCA LM124AJRLQMLV, 5962R9950402VDA LM124AWRLQMLV, 5962R9950402VZA LM124AWGRLQMLV, and reference to Note 10 and 11. Deleted code K NSID's LM124AJLQMLV 5962L9950401VCA, LM124AWGLQMLV 5962L9950401VZA, LM124AWLQMLV 5962L9950401VDA, Note 11 to Rad Hard Electrical Heading. Note 11 to Notes.
10/07/2010	E	Data sheet title, Features, Ordering table, Electrical characteristic headings, Rad Hard conditions	Update with current device information and format. Revision D will be Archived
03/26/2013	K	All Sections	Changed layout of National Data Sheet to TI format

**PACKAGING INFORMATION**

Orderable Device	Status (1)	Package Type	Package Drawing	Pins	Package Qty	Eco Plan (2)	Lead/Ball Finish	MSL Peak Temp (3)	Op Temp (°C)	Top-Side Markings (4)	Samples
5962R9950401V9A	ACTIVE	DIESALE	Y	0	30	Green (RoHS & no Sb/Br)	Call TI	Level-1-NA-UNLIM	-55 to 125		<a href="#">Samples</a>
5962R9950401VCA	ACTIVE	CDIP	J	14	25	TBD	Call TI	Call TI	-55 to 125	LM124AJRQMLV 5962R9950401VCA Q	<a href="#">Samples</a>
5962R9950401VDA	ACTIVE	CFP	NAD	14	19	TBD	Call TI	Call TI	-55 to 125	LM124AWR (LQMLV Q ~ QMLV Q) 5962R99504 01VZA ACO 01VZA >T	<a href="#">Samples</a>
5962R9950401VZA	ACTIVE	CFP	NAC	14	42	TBD	Call TI	Call TI	-55 to 125	LM124AWGR QMLV Q 5962R99504 01VZA ACO 01VZA >T	<a href="#">Samples</a>
5962R9950402V9A	ACTIVE	DIESALE	Y	0	30	Green (RoHS & no Sb/Br)	Call TI	Level-1-NA-UNLIM	-55 to 125		<a href="#">Samples</a>
5962R9950402VCA	ACTIVE	CDIP	J	14	25	TBD	Call TI	Call TI	-55 to 125	LM124AJRLQMLV 5962R9950402VCA Q	<a href="#">Samples</a>
5962R9950402VDA	ACTIVE	CFP	NAD	14	19	TBD	Call TI	Call TI	-55 to 125	LM124AWR LQMLV Q 5962R99504 02VZA ACO 02VZA >T	<a href="#">Samples</a>
5962R9950402VZA	ACTIVE	CFP	NAC	14	42	TBD	Call TI	Call TI	-55 to 125	LM124AWGR LQMLV Q 5962R99504 02VZA ACO (5962-87608 ~ 5962R99504) 02VZA >T	<a href="#">Samples</a>
7704302XA	ACTIVE	CFP	NAC	14	42	TBD	Call TI	Call TI	-55 to 125	LM124AWG /883 Q 5962-77043 02XA ACO 02XA >T	<a href="#">Samples</a>
LM124 MDE	ACTIVE	DIESALE	Y	0	30	Green (RoHS & no Sb/Br)	Call TI	Level-1-NA-UNLIM	-55 to 125		<a href="#">Samples</a>

Orderable Device	Status (1)	Package Type	Package Drawing	Pins	Package Qty	Eco Plan (2)	Lead/Ball Finish	MSL Peak Temp (3)	Op Temp (°C)	Top-Side Markings (4)	Samples
LM124 MDR	ACTIVE	DIESALE	Y	0	30	Green (RoHS & no Sb/Br)	Call TI	Level-1-NA-UNLIM	-55 to 125		<a href="#">Samples</a>
LM124AE/883	ACTIVE	LCCC	NAJ	20	50	TBD	Call TI	Call TI	-55 to 125	LM124AE /883 Q 5962-77043 022A ACO 022A >T	<a href="#">Samples</a>
LM124AJ/883	ACTIVE	CDIP	J	14	25	TBD	Call TI	Call TI	-55 to 125	LM124AJ/883 (5962-7704302CA Q ~ 5962-7704302 CA Q )	<a href="#">Samples</a>
LM124AJRLQMLV	ACTIVE	CDIP	J	14	25	TBD	Call TI	Call TI	-55 to 125	LM124AJRLQMLV 5962R9950402VCA Q	<a href="#">Samples</a>
LM124AJRQMLV	ACTIVE	CDIP	J	14	25	TBD	Call TI	Call TI	-55 to 125	LM124AJRQMLV 5962R9950401VCA Q	<a href="#">Samples</a>
LM124AW/883	ACTIVE	CFP	NAD	14	19	TBD	Call TI	Call TI	-55 to 125	LM124AW /883 Q ACO /883 Q >T	<a href="#">Samples</a>
LM124AWG/883	ACTIVE	CFP	NAC	14	42	TBD	Call TI	Call TI	-55 to 125	LM124AWG /883 Q 5962-77043 02XA ACO 02XA >T	<a href="#">Samples</a>
LM124AWGRLQMLV	ACTIVE	CFP	NAC	14	42	TBD	Call TI	Call TI	-55 to 125	LM124AWGR LQMLV Q 5962R99504 02VZA ACO (5962-87608 ~ 5962R99504) 02VZA >T	<a href="#">Samples</a>
LM124AWGRQMLV	ACTIVE	CFP	NAC	14	42	TBD	Call TI	Call TI	-55 to 125	LM124AWGR QMLV Q 5962R99504 01VZA ACO 01VZA >T	<a href="#">Samples</a>
LM124AWRLQMLV	ACTIVE	CFP	NAD	14	19	TBD	Call TI	Call TI	-55 to 125	LM124AWR LQMLV Q 5962R99504 02VZA ACO	<a href="#">Samples</a>



Orderable Device	Status (1)	Package Type	Package Drawing	Pins	Package Qty	Eco Plan (2)	Lead/Ball Finish	MSL Peak Temp (3)	Op Temp (°C)	Top-Side Markings (4)	Samples
										02VZA >T	
LM124AWRQMLV	ACTIVE	CFP	NAD	14	19	TBD	Call TI	Call TI	-55 to 125	LM124AWR (LQMLV Q ~ QMLV Q) 5962R99504 01VZA ACO 01VZA >T	<a href="#">Samples</a>
LM124J/883	ACTIVE	CDIP	J	14	25	TBD	Call TI	Call TI	-55 to 125	LM124J/883 (5962-7704301CA Q ~ 5962-7704301 CA Q )	<a href="#">Samples</a>

(1) The marketing status values are defined as follows:

**ACTIVE:** Product device recommended for new designs.

**LIFEBUY:** TI has announced that the device will be discontinued, and a lifetime-buy period is in effect.

**NRND:** Not recommended for new designs. Device is in production to support existing customers, but TI does not recommend using this part in a new design.

**PREVIEW:** Device has been announced but is not in production. Samples may or may not be available.

**OBSELETE:** TI has discontinued the production of the device.

(2) Eco Plan - The planned eco-friendly classification: Pb-Free (RoHS), Pb-Free (RoHS Exempt), or Green (RoHS & no Sb/Br) - please check <http://www.ti.com/productcontent> for the latest availability information and additional product content details.

**TBD:** The Pb-Free/Green conversion plan has not been defined.

**Pb-Free (RoHS):** TI's terms "Lead-Free" or "Pb-Free" mean semiconductor products that are compatible with the current RoHS requirements for all 6 substances, including the requirement that lead not exceed 0.1% by weight in homogeneous materials. Where designed to be soldered at high temperatures, TI Pb-Free products are suitable for use in specified lead-free processes.

**Pb-Free (RoHS Exempt):** This component has a RoHS exemption for either 1) lead-based flip-chip solder bumps used between the die and package, or 2) lead-based die adhesive used between the die and leadframe. The component is otherwise considered Pb-Free (RoHS compatible) as defined above.

**Green (RoHS & no Sb/Br):** TI defines "Green" to mean Pb-Free (RoHS compatible), and free of Bromine (Br) and Antimony (Sb) based flame retardants (Br or Sb do not exceed 0.1% by weight in homogeneous material)

(3) MSL, Peak Temp. -- The Moisture Sensitivity Level rating according to the JEDEC industry standard classifications, and peak solder temperature.

(4) Multiple Top-Side Markings will be inside parentheses. Only one Top-Side Marking contained in parentheses and separated by a "~" will appear on a device. If a line is indented then it is a continuation of the previous line and the two combined represent the entire Top-Side Marking for that device.

**Important Information and Disclaimer:** The information provided on this page represents TI's knowledge and belief as of the date that it is provided. TI bases its knowledge and belief on information provided by third parties, and makes no representation or warranty as to the accuracy of such information. Efforts are underway to better integrate information from third parties. TI has taken and continues to take reasonable steps to provide representative and accurate information but may not have conducted destructive testing or chemical analysis on incoming materials and chemicals. TI and TI suppliers consider certain information to be proprietary, and thus CAS numbers and other limited information may not be available for release.

In no event shall TI's liability arising out of such information exceed the total purchase price of the TI part(s) at issue in this document sold by TI to Customer on an annual basis.

**OTHER QUALIFIED VERSIONS OF LM124AQML, LM124AQML-SP :**

- Military: [LM124AQML](#)
- Space: [LM124AQML-SP](#)

## NOTE: Qualified Version Definitions:

- Military - QML certified for Military and Defense Applications
- Space - Radiation tolerant, ceramic packaging and qualified for use in Space-based application

J (R-GDIP-T\*\*)

14 LEADS SHOWN

CERAMIC DUAL IN-LINE PACKAGE



DIM \ PINS **	14	16	18	20
A	0.300 (7,62) BSC	0.300 (7,62) BSC	0.300 (7,62) BSC	0.300 (7,62) BSC
B MAX	0.785 (19,94)	.840 (21,34)	0.960 (24,38)	1.060 (26,92)
B MIN	—	—	—	—
C MAX	0.300 (7,62)	0.300 (7,62)	0.310 (7,87)	0.300 (7,62)
C MIN	0.245 (6,22)	0.245 (6,22)	0.220 (5,59)	0.245 (6,22)



4040083/F 03/03

- NOTES:
- All linear dimensions are in inches (millimeters).
  - This drawing is subject to change without notice.
  - This package is hermetically sealed with a ceramic lid using glass frit.
  - Index point is provided on cap for terminal identification only on press ceramic glass frit seal only.
  - Falls within MIL STD 1835 GDIP1-T14, GDIP1-T16, GDIP1-T18 and GDIP1-T20.

NAJ0020A

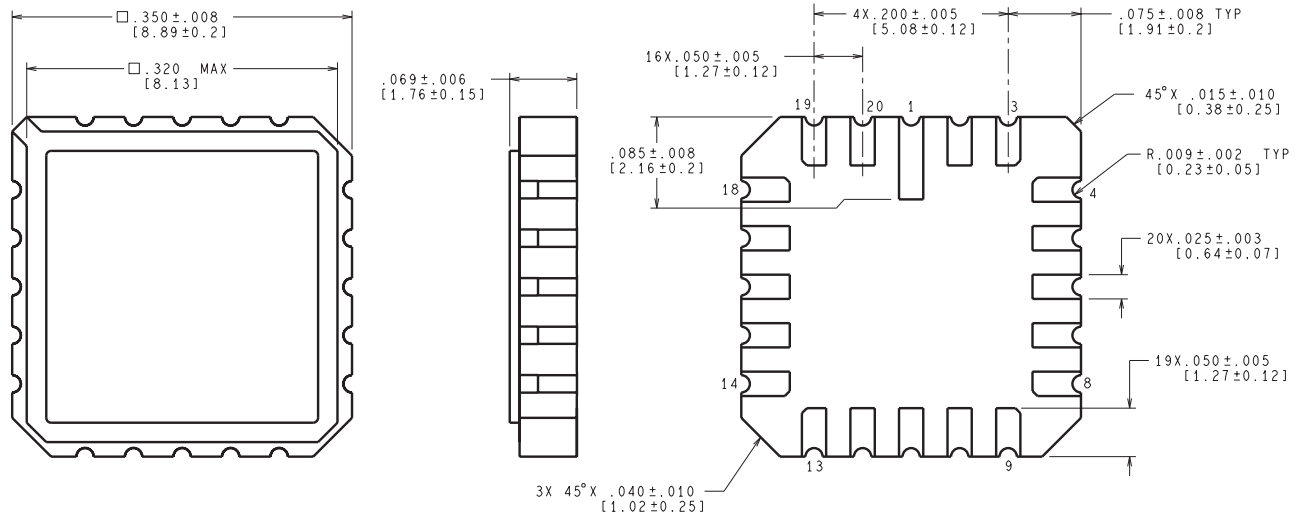

CONTROLLING DIMENSION IS INCH  
VALUES IN [ ] ARE MILLIMETERS

E20A (Rev F)

NAC0014A

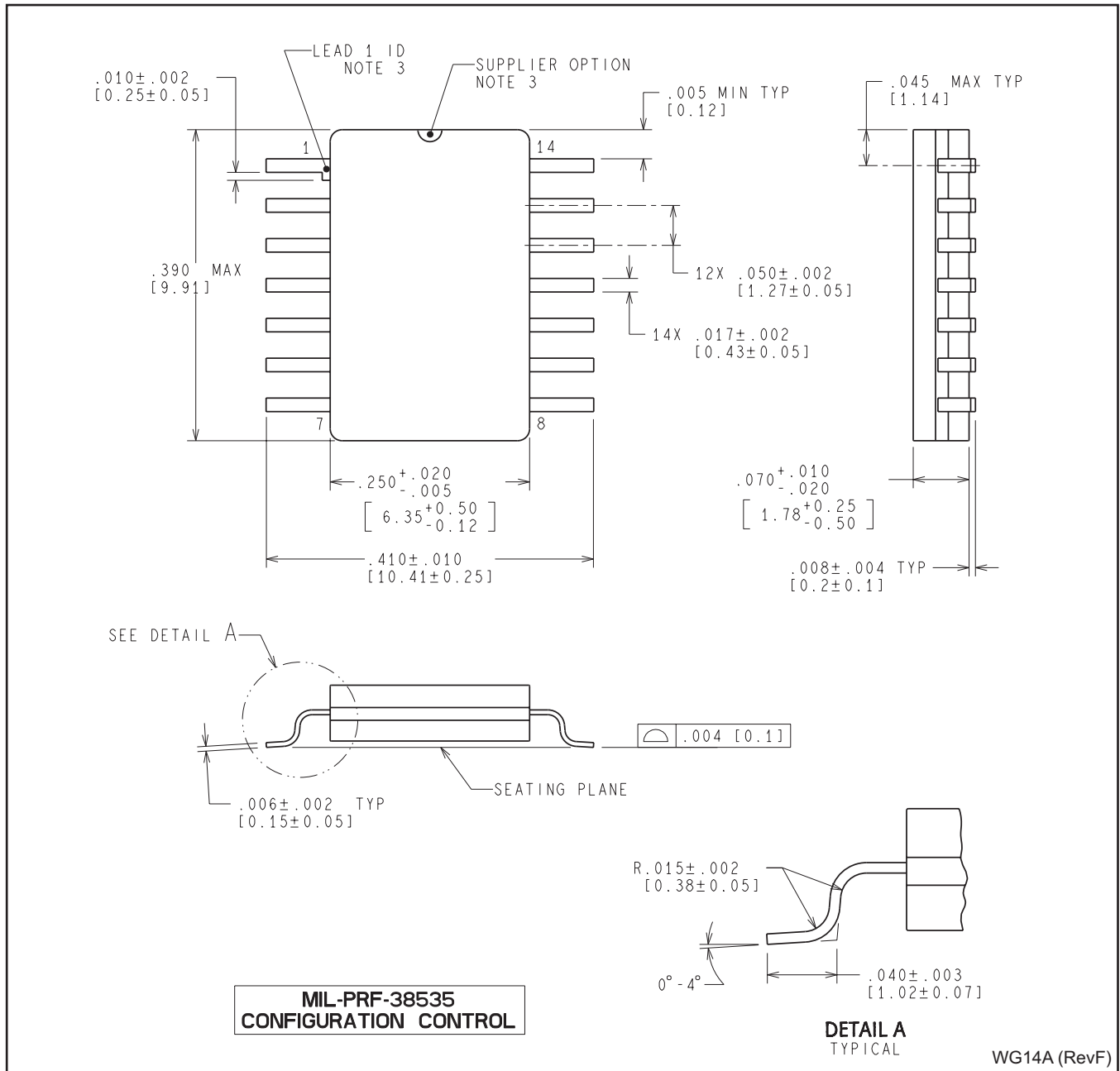

NAD0014B

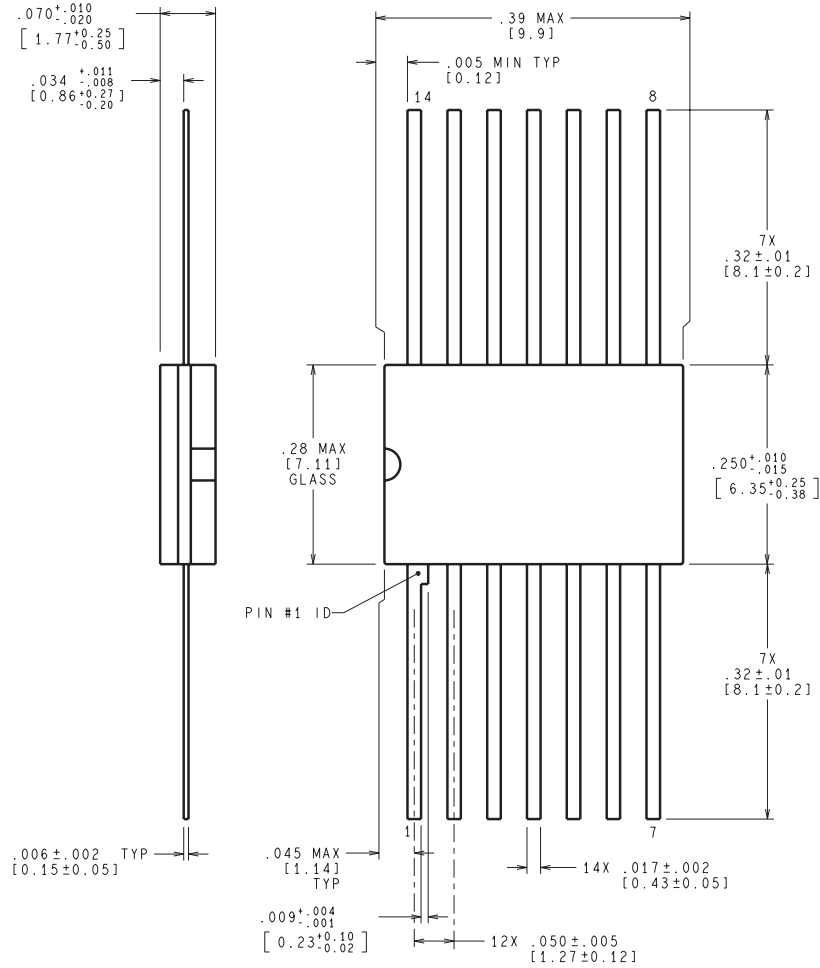

MIL-PRF-38535  
CONFIGURATION CONTROL

MIL-STD-1835B  
CONFIGURATION CONTROL

CONTROLLING DIMENSION IS INCH  
VALUES IN [ ] ARE MILLIMETERS

W14B (Rev P)

## IMPORTANT NOTICE

Texas Instruments Incorporated and its subsidiaries (TI) reserve the right to make corrections, enhancements, improvements and other changes to its semiconductor products and services per JESD46, latest issue, and to discontinue any product or service per JESD48, latest issue. Buyers should obtain the latest relevant information before placing orders and should verify that such information is current and complete. All semiconductor products (also referred to herein as "components") are sold subject to TI's terms and conditions of sale supplied at the time of order acknowledgment.

TI warrants performance of its components to the specifications applicable at the time of sale, in accordance with the warranty in TI's terms and conditions of sale of semiconductor products. Testing and other quality control techniques are used to the extent TI deems necessary to support this warranty. Except where mandated by applicable law, testing of all parameters of each component is not necessarily performed.

TI assumes no liability for applications assistance or the design of Buyers' products. Buyers are responsible for their products and applications using TI components. To minimize the risks associated with Buyers' products and applications, Buyers should provide adequate design and operating safeguards.

TI does not warrant or represent that any license, either express or implied, is granted under any patent right, copyright, mask work right, or other intellectual property right relating to any combination, machine, or process in which TI components or services are used. Information published by TI regarding third-party products or services does not constitute a license to use such products or services or a warranty or endorsement thereof. Use of such information may require a license from a third party under the patents or other intellectual property of the third party, or a license from TI under the patents or other intellectual property of TI.

Reproduction of significant portions of TI information in TI data books or data sheets is permissible only if reproduction is without alteration and is accompanied by all associated warranties, conditions, limitations, and notices. TI is not responsible or liable for such altered documentation. Information of third parties may be subject to additional restrictions.

Resale of TI components or services with statements different from or beyond the parameters stated by TI for that component or service voids all express and any implied warranties for the associated TI component or service and is an unfair and deceptive business practice. TI is not responsible or liable for any such statements.

Buyer acknowledges and agrees that it is solely responsible for compliance with all legal, regulatory and safety-related requirements concerning its products, and any use of TI components in its applications, notwithstanding any applications-related information or support that may be provided by TI. Buyer represents and agrees that it has all the necessary expertise to create and implement safeguards which anticipate dangerous consequences of failures, monitor failures and their consequences, lessen the likelihood of failures that might cause harm and take appropriate remedial actions. Buyer will fully indemnify TI and its representatives against any damages arising out of the use of any TI components in safety-critical applications.

In some cases, TI components may be promoted specifically to facilitate safety-related applications. With such components, TI's goal is to help enable customers to design and create their own end-product solutions that meet applicable functional safety standards and requirements. Nonetheless, such components are subject to these terms.

No TI components are authorized for use in FDA Class III (or similar life-critical medical equipment) unless authorized officers of the parties have executed a special agreement specifically governing such use.

Only those TI components which TI has specifically designated as military grade or "enhanced plastic" are designed and intended for use in military/aerospace applications or environments. Buyer acknowledges and agrees that any military or aerospace use of TI components which have **not** been so designated is solely at the Buyer's risk, and that Buyer is solely responsible for compliance with all legal and regulatory requirements in connection with such use.

TI has specifically designated certain components as meeting ISO/TS16949 requirements, mainly for automotive use. In any case of use of non-designated products, TI will not be responsible for any failure to meet ISO/TS16949.

### Products

Audio	<a href="http://www.ti.com/audio">www.ti.com/audio</a>
Amplifiers	<a href="http://amplifier.ti.com">amplifier.ti.com</a>
Data Converters	<a href="http://dataconverter.ti.com">dataconverter.ti.com</a>
DLP® Products	<a href="http://www.dlp.com">www.dlp.com</a>
DSP	<a href="http://dsp.ti.com">dsp.ti.com</a>
Clocks and Timers	<a href="http://www.ti.com/clocks">www.ti.com/clocks</a>
Interface	<a href="http://interface.ti.com">interface.ti.com</a>
Logic	<a href="http://logic.ti.com">logic.ti.com</a>
Power Mgmt	<a href="http://power.ti.com">power.ti.com</a>
Microcontrollers	<a href="http://microcontroller.ti.com">microcontroller.ti.com</a>
RFID	<a href="http://www.ti-rfid.com">www.ti-rfid.com</a>
OMAP Applications Processors	<a href="http://www.ti.com/omap">www.ti.com/omap</a>
Wireless Connectivity	<a href="http://www.ti.com/wirelessconnectivity">www.ti.com/wirelessconnectivity</a>

### Applications

Automotive and Transportation	<a href="http://www.ti.com/automotive">www.ti.com/automotive</a>
Communications and Telecom	<a href="http://www.ti.com/communications">www.ti.com/communications</a>
Computers and Peripherals	<a href="http://www.ti.com/computers">www.ti.com/computers</a>
Consumer Electronics	<a href="http://www.ti.com/consumer-apps">www.ti.com/consumer-apps</a>
Energy and Lighting	<a href="http://www.ti.com/energy">www.ti.com/energy</a>
Industrial	<a href="http://www.ti.com/industrial">www.ti.com/industrial</a>
Medical	<a href="http://www.ti.com/medical">www.ti.com/medical</a>
Security	<a href="http://www.ti.com/security">www.ti.com/security</a>
Space, Avionics and Defense	<a href="http://www.ti.com/space-avionics-defense">www.ti.com/space-avionics-defense</a>
Video and Imaging	<a href="http://www.ti.com/video">www.ti.com/video</a>

### TI E2E Community

[e2e.ti.com](http://e2e.ti.com)