

LM119QML High Speed Dual Comparator

 Check for Samples: [LM119QML](#)

FEATURES

- Available with radiation ensured
 - High Dose Rate 100 krad(Si)
 - ELDRS Free 100 krad(Si)
- Two independent comparators
- Operates from a single 5V supply
- Typically 80 ns response time at $\pm 15V$
- Minimum fan-out of 2 each side
- Maximum input current of 1 μA over temperature
- Inputs and outputs can be isolated from system ground
- High common mode slew rate

DESCRIPTION

The LM119 is a precision high speed dual comparator fabricated on a single monolithic chip. It is designed to operate over a wide range of supply voltages down to a single 5V logic supply and ground. Further, it has higher gain and lower input currents than devices like the LM710. The uncommitted collector of the output stage makes the LM119 compatible with RTL, DTL and TTL as well as capable of driving lamps and relays at currents up to 25 mA.

Although designed primarily for applications requiring operation from digital logic supplies, the LM119 is fully specified for power supplies up to $\pm 15V$. It features faster response than the LM111 at the expense of higher power dissipation. However, the high speed, wide operating voltage range and low package count make the LM119 much more versatile than older devices like the LM711.

Connection Diagrams

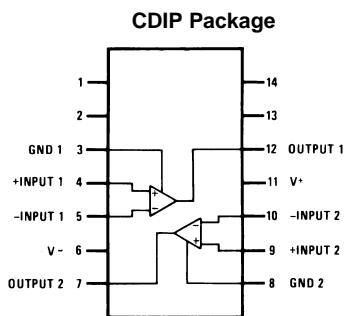

**Figure 1. Top View
Package Number J0014A**

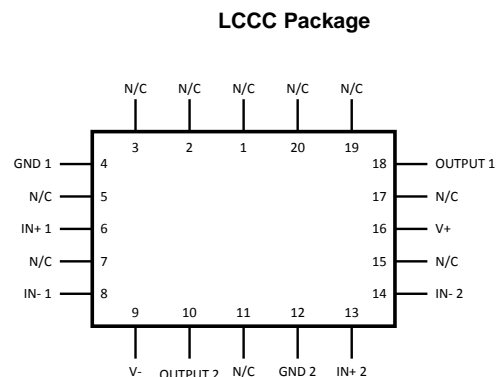

**Figure 2. Top View
Package Number NAJ0020A**

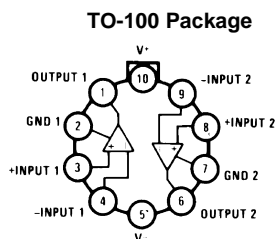

**Figure 3. Top View
Package Number LME0010C**

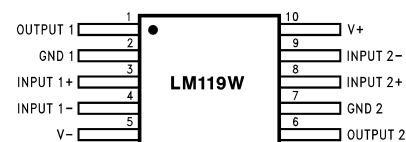

**Figure 4. Top View
Package Number NAD0010A, NAC0010A**

Case is connected to pin 5 (V^-).



Please be aware that an important notice concerning availability, standard warranty, and use in critical applications of Texas Instruments semiconductor products and disclaimers thereto appears at the end of this data sheet.

All trademarks are the property of their respective owners.

Schematic Diagram

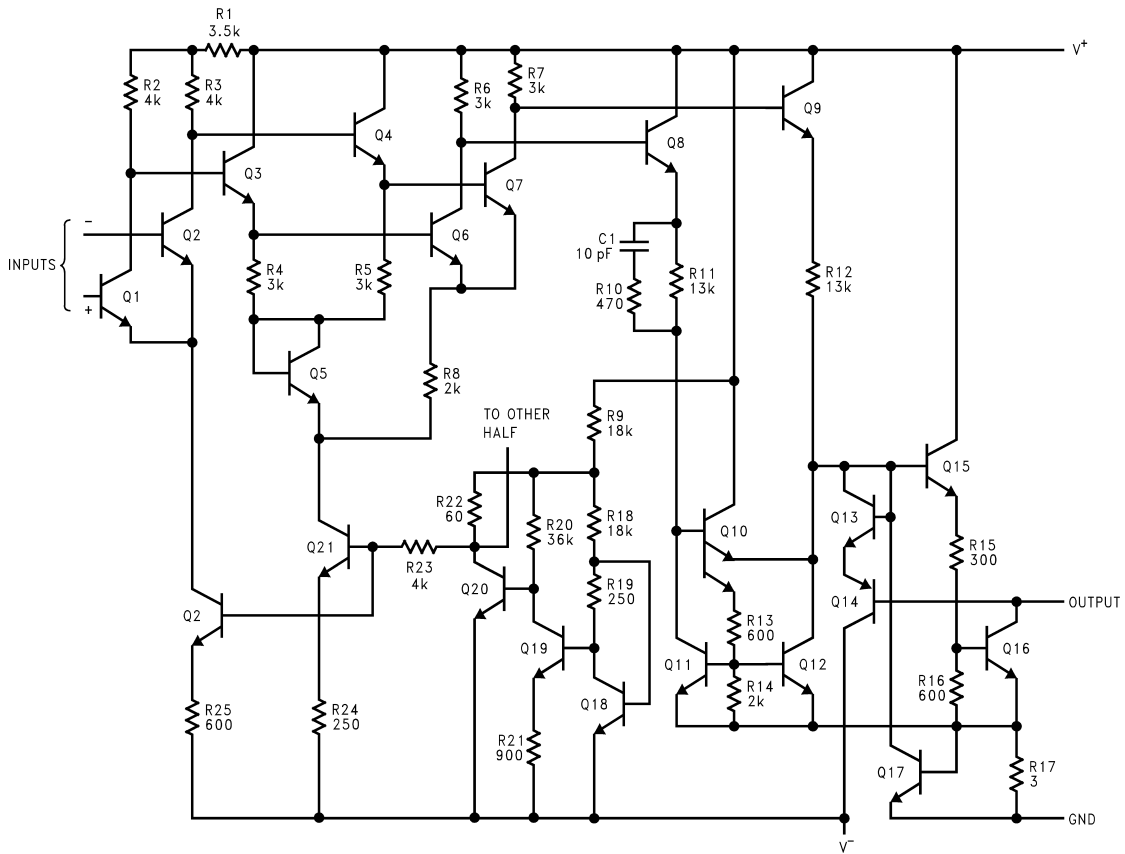

*Do not operate the LM119 with more than 16V between GND and V+



These devices have limited built-in ESD protection. The leads should be shorted together or the device placed in conductive foam during storage or handling to prevent electrostatic damage to the MOS gates.

Absolute Maximum Ratings ⁽¹⁾

Total Supply Voltage	36V
Output to Negative Supply Voltage	36V
Ground to Negative Supply Voltage	25V
Ground to Positive Supply Voltage	18V
Differential Input Voltage	±5V
Input Voltage ⁽²⁾	±15V
Power Dissipation ⁽³⁾	500 mW
Output Short Circuit Duration	10 sec
Storage Temperature Range	-65°C ≤ T _A ≤ 150°C
Operating Ambient Temperature Range	-55°C ≤ T _A ≤ 125°C
Maximum Junction Temperature (T _J)	150°C
Lead Temperature (Soldering, 10 sec.)	260°C
Thermal Resistance	
θ_{JA}	
LCCC Package (Still Air)	89°C/W
LCCC Package (500LF/Min Air flow)	63°C/W
TO-100 Package (Still Air)	162°C/W
TO-100 Package (500LF/Min Air flow)	88°C/W
CDIP Package (Still Air)	94°C/W
CDIP Package (500LF/Min Air flow)	52°C/W
CLGA Package (Still Air)	215°C/W
CLGA Package (500LF/Min Air flow)	132°C/W
CLGA Package (Still Air)	215°C/W
CLGA Package (500LF/Min Air flow)	132°C/W
θ_{JC}	
LCCC Package	5°C/W
TO-100 Package	31°C/W
CDIP Package	11°C/W
CLGA Package	13°C/W
CLGA Package	13°C/W
Package Weight	
LCCC Package	TBD
TO-100 Package	TBD
CDIP Package	TBD
CLGA Package	TBD
CLGA Package	225mg
ESD rating ⁽⁴⁾	800V

- (1) Absolute Maximum Ratings indicate limits beyond which damage to the device may occur. Operating Ratings indicate conditions for which the device is functional, but do not ensure specific performance limits. For ensured specifications and test conditions, see the Electrical Characteristics. The ensured specifications apply only for the test conditions listed. Some performance characteristics may degrade when the device is not operated under the listed test conditions.
- (2) For supply voltages less than ±15V the absolute maximum input voltage is equal to the supply voltage.
- (3) The maximum power dissipation must be derated at elevated temperatures and is dictated by T_{Jmax} (maximum junction temperature), θ_{JA} (package junction to ambient thermal resistance), and T_A (ambient temperature). The maximum allowable power dissipation at any temperature is P_{Dmax} = (T_{Jmax} - T_A)/θ_{JA} or the number given in the Absolute Maximum Ratings, whichever is lower.
- (4) Human Body model, 1.5KΩ in series with 100pF.

Table 1. Quality Conformance Inspection⁽¹⁾

Subgroup	Description	Temp °C
1	Static tests at	25
2	Static tests at	125
3	Static tests at	-55
4	Dynamic tests at	25
5	Dynamic tests at	125
6	Dynamic tests at	-55
7	Functional tests at	25
8A	Functional tests at	125
8B	Functional tests at	-55
9	Switching tests at	25
10	Switching tests at	125
11	Switching tests at	-55
12	Settling time at	25
13	Settling time at	125
14	Settling time at	-55

(1) Mil-Std-883, Method 5005 - Group 5

LM119/883 Electrical Characteristics DC Parameters

The following conditions apply, unless otherwise specified. $V_{CM} = 0V$

Symbol	Parameter	Conditions	Notes	Min	Max	Units	Sub-groups	
+I _{CC}	Positive Supply Current	$\pm V_{CC} = \pm 15V$, $V_O = \text{Low}$ $V^+ = 5.6V$ thru $1.4K\Omega$			11	mA	1	
					11.5	mA	2	
-I _{CC}	Negative Supply Current	$\pm V_{CC} = \pm 15V$, $V_O = \text{Low}$ $V^+ = 5.6V$ thru $1.4K\Omega$			-4.2	mA	1	
					-4.5	mA	2	
I _{Leak}	Output Leakage Current	$+V_{CC} = 15V$, $-V_{CC} = -1V$, $V_{Gnd} = 0V$, $V_O = 35V$, $V_I = 5mV$			1.8	μA	1	
					9.5	μA	2	
					10.0	μA	3	
I _{IB}	Input Bias Current	$\pm V_{CC} = \pm 15V$			0.47 5	μA	1	
					0.95	μA	2, 3	
					0.47 5	μA	1	
					.95	μA	2, 3	
V _{IO}	Input Offset Voltage	$+V_{CC} = 5V$, $-V_{CC} = 0V$, $V_{CM} = 1V$, $R_S \leq 5K\Omega$			-3.8	3.8	mV	1
					-6.8	6.8	mV	2, 3
		$+V_{CC} = 5V$, $-V_{CC} = 0V$, $V_{CM} = 3V$, $R_S \leq 5K\Omega$			-3.8	3.8	mV	1
					-6.8	6.8	mV	2, 3
		$\pm V_{CC} = \pm 15V$, $V_{CM} = 12V$, $R_S \leq 5K\Omega$			-3.8	3.8	mV	1
					-6.8	6.8	mV	2, 3
		$\pm V_{CC} = \pm 15V$, $V_{CM} = -12V$, $R_S \leq 5K\Omega$			-3.8	3.8	mV	1
					-6.8	6.8	mV	2, 3
I _{IO}	Input Offset Current	$+V_{CC} = 5V$, $-V_{CC} = 0V$, $V_{CM} = 1V$			-75	75	nA	1
					-100	100	nA	2, 3
		$+V_{CC} = 5V$, $-V_{CC} = 0V$, $V_{CM} = 3V$			-75	75	nA	1
					-100	100	nA	2, 3
		$\pm V_{CC} = \pm 15V$, $V_{CM} = 12V$			-75	75	nA	1
					-100	100	nA	2, 3
		$\pm V_{CC} = \pm 15V$, $V_{CM} = -12V$			-75	75	nA	1
					-100	100	nA	2, 3
V _{Sat}	Output Saturation Voltage	$\pm V_{CC} = \pm 15V$, $I_O = 25mA$, $V_I = -5mV$			1.5	V	1	
					(1)	0.4	V	1, 2
					(1)	0.6	V	3
A _V	Voltage Gain	$\pm V_{CC} = \pm 15V$, $\Delta V_O = 12V$, $R_L = 1.4K\Omega$		(2), (3)	10.5	K	4	
				(2), (3)	10	K	5, 6	
		$+V_{CC} = 5V$, $-V_{CC} = 0V$, $\Delta V_O = 4.5V$, $R_L = 1.4K\Omega$		(2), (4)	8.0	K	4	
				(2), (4)	5.0	K	5	
				(2), (4)	5.8	K	6	

(1) Output is monitored by measuring V_I with limits from 0 to 6mV at all temperatures

(2) $K = V/mV$.

(3) Gain is computed with an output swing from +13.5V to +1.5V.

(4) Gain is computed with an output swing from +5.0V to +0.5V.

LM119-SMD Electrical Characteristics SMD 8601401 DC Parameters

The following conditions apply, unless otherwise specified. $V_{CM} = 0V$

Symbol	Parameter	Conditions	Notes	Min	Max	Units	Sub-groups	
$+I_{CC}$	Positive Supply Current	$\pm V_{CC} = \pm 15V$, $V_O = \text{Low}$ $V^+ = 5.6V$ thru $1.4K\Omega$			11	mA	1	
					11.5	mA	2, 3	
$-I_{CC}$	Negative Supply Current	$\pm V_{CC} = \pm 15V$, $V_O = \text{Low}$ $V^+ = 5.6V$ thru $1.4K\Omega$			-4.2	mA	1	
					-4.5	mA	2	
					-6.0	mA	3	
I_{Leak}	Output Leakage Current	$+V_{CC} = 15V$, $V_{CC} = -1V$, $V_{Gnd} = 0V$, $V_O = 35V$	(1)		1.8	μA	1	
				(1)	10	μA	2, 3	
I_{IB}	Input Bias Current	$\pm V_{CC} = \pm 15V$			0.47 5	μA	1	
					0.95	μA	2, 3	
		$+V_{CC} = 5V$	(2)		0.47 5	μA	1	
				(2)	.95	μA	2, 3	
V_{IO}	Input Offset Voltage	$+V_{CC} = 5V$, $V_{CM} = 1V$, $R_S \leq 5K\Omega$	(2)		-3.8	3.8	mV	1
				(2)	-6.8	6.8	mV	2, 3
		$+V_{CC} = 5V$, $V_{CM} = 3V$, $R_S \leq 5K\Omega$	(2)		-3.8	3.8	mV	1
				(2)	-6.8	6.8	mV	2, 3
		$\pm V_{CC} = \pm 15V$, $V_{CM} = 12V$, $R_S \leq 5K\Omega$			-3.8	3.8	mV	1
					-6.8	6.8	mV	2, 3
I_{IO}	Input Offset Current	$+V_{CC} = 5V$, $V_{CM} = 1V$	(2)		-75	75	nA	1
				(2)	-100	100	nA	2, 3
		$+V_{CC} = 5V$, $V_{CM} = 3V$	(2)		-75	75	nA	1
				(2)	-100	100	nA	2, 3
		$\pm V_{CC} = \pm 15V$, $V_{CM} = 12V$			-75	75	nA	1
					-100	100	nA	2, 3
$\pm V_{CC} = \pm 15V$, $V_{CM} = -12V$			-75	75	nA	1		
			-100	100	nA	2, 3		
V_I	Input Voltage Range	$+V_{CC} = 5V$	(2), (3)	1.0	3.0	V	1, 2, 3	
		$\pm V_{CC} = \pm 15V$	(3)	-12	12	V	1, 2, 3	
V_{Sat}	Output Saturation Voltage	$\pm V_{CC} = \pm 15V$, $I_O = 25mA$, $V_I \leq -5mV$	(1)		1.5	V	1, 2, 3	
					0.4	V	1, 2	
					0.6	V	3	
A_V	Voltage Gain	$\pm V_{CC} = \pm 15V$, $\Delta V_O = 12V$, $R_L = 1.4K\Omega$	(4)		10.5	K	4	
				(4)	10	K	5, 6	
		$+V_{CC} = 5V$, $V_{CC} = 0V$, $\Delta V_O = 4.5V$, $R_L = 1.4K\Omega$	(2), (4)		8.0	K	4	
				(2), (4)	5.0	K	5	
				(2), (4)	5.8	K	6	
CMRR	Common Mode Rejection Ratio	$\pm V_{CC} = \pm 15V$, $V_{CM} = \pm 12V$		80		dB	4	

(1) $V_I \geq 8mV$ at extremes for I_{Leak} and $V_I \leq -8mV$ at extremes for V_{Sat} (V_I to exceed V_{OS}).

(2) 5V differential across $+V_{CC}$ and $-V_{CC}$.

(3) Parameter ensured by V_{IO} and I_{IO} tests.

(4) $K = V/mV$.

LM119 Electrical Characteristics SMD 5962-9679801, HIGH DOSE RATE DC Parameters

 The following conditions apply, unless otherwise specified. $V_{CM} = 0V$

Symbol	Parameter	Conditions	Notes	Min	Max	Units	Sub-groups	
$+I_{CC}$	Positive Supply Current	$\pm V_{CC} = \pm 15V$, $V_O = \text{Low}$ $V^+ = 5.6V$ thru $1.4K\Omega$			11	mA	1	
					11.5	mA	2, 3	
$-I_{CC}$	Negative Supply Current	$\pm V_{CC} = \pm 15V$, $V_O = \text{Low}$ $V^+ = 5.6V$ thru $1.4K\Omega$			-4.2	mA	1	
					-4.5	mA	2	
					-6.0	mA	3	
I_{Leak}	Output Leakage Current	$+V_{CC} = 15V$, $V_{CC} = -1V$, $V_{Gnd} = 0V$, $V_O = 35V$	(1)		1.8	μA	1	
				(1)	10	μA	2, 3	
I_{IB}	Input Bias Current	$\pm V_{CC} = \pm 15V$			0.47 5	μA	1	
					0.95	μA	2, 3	
		$+V_{CC} = 5V$	(2)		0.47 5	μA	1	
				(2)	.95	μA	2, 3	
V_{IO}	Input Offset Voltage	$+V_{CC} = 5V$, $V_{CM} = 1V$, $R_S \leq 5K\Omega$	(2)		-3.8	3.8	mV	1
				(2)	-6.8	6.8	mV	2, 3
		$+V_{CC} = 5V$, $V_{CM} = 3V$, $R_S \leq 5K\Omega$	(2)		-3.8	3.8	mV	1
				(2)	-6.8	6.8	mV	2, 3
		$\pm V_{CC} = \pm 15V$, $V_{CM} = 12V$, $R_S \leq 5K\Omega$			-3.8	3.8	mV	1
					-6.8	6.8	mV	2, 3
I_{IO}	Input Offset Current	$+V_{CC} = 5V$, $V_{CM} = 1V$	(2)		-75	75	nA	1
				(2)	-100	100	nA	2, 3
		$+V_{CC} = 5V$, $V_{CM} = 3V$	(2)		-75	75	nA	1
				(2)	-100	100	nA	2, 3
		$\pm V_{CC} = \pm 15V$, $V_{CM} = 12V$			-75	75	nA	1
					-100	100	nA	2, 3
$\pm V_{CC} = \pm 15V$, $V_{CM} = -12V$			-75	75	nA	1		
			-100	100	nA	2, 3		
V_I	Input Voltage Range	$+V_{CC} = 5V$ $\pm V_{CC} = \pm 15V$	(2), (3)		1.0	3.0	V	1, 2, 3
				(3)	-12	12	V	1, 2, 3
V_{Sat}	Output Saturation Voltage	$\pm V_{CC} = \pm 15V$, $I_O = 25mA$, $V_I \leq -5mV$	(1)		1.5	V	1, 2, 3	
					0.4	V	1, 2	
					0.6	V	3	
A_V	Voltage Gain	$\pm V_{CC} = \pm 15V$, $\Delta V_O = 12V$, $R_L = 1.4K\Omega$	(4)		10.5	K	4	
				(4)	10	K	5, 6	
		$+V_{CC} = 5V$, $V_{CC} = 0V$, $\Delta V_O = 4.5V$, $R_L = 1.4K\Omega$	(2), (4)		8.0	K	4	
				(2), (4)	5.0	K	5	
				(2), (4)	5.8	K	6	
CMRR	Common Mode Rejection Ratio	$\pm V_{CC} = \pm 15V$, $V_{CM} = \pm 12V$		80		dB	4	

 (1) $V_I \geq 8mV$ at extremes for I_{Leak} and $V_I \leq -8mV$ at extremes for V_{Sat} (V_I to exceed V_{OS}).

 (2) 5V differential across $+V_{CC}$ and $-V_{CC}$.

 (3) Parameter ensured by V_{IO} and I_{IO} tests.

 (4) $K = V/mV$.

SMD 5962-9679801, HIGH DOSE RATE DC DELTA Parameters

The following conditions apply, unless otherwise specified.

$V_{CM} = 0V$, Delta calculations performed on QMLV devices at group B, subgroup 5 only.

Symbol	Parameter	Conditions	Notes	Min	Max	Units	Sub-groups
$+I_{CC}$	Positive Supply Current	$\pm V_{CC} = \pm 15V$, $V_O = \text{Low}$ $V^+ = 5.6V$ thru $1.4K\Omega$		-1.0	1.0	mA	1
$-I_{CC}$	Negative Supply Current	$\pm V_{CC} = \pm 15V$, $V_O = \text{Low}$ $V^+ = 5.6V$ thru $1.4K\Omega$		-0.5	0.5	mA	1
V_{IO}	Input Offset Voltage	$+V_{CC} = 5V$, $V_{CM} = 1V$, $R_S \leq 5K\Omega$		-0.4	0.4	mV	1

SMD 5962-9679801, High Dose Rate 100K Post Radiation Parameters @ 25°C ⁽¹⁾

The following conditions apply, unless otherwise specified. $V_{CM} = 0V$

Symbol	Parameter	Conditions	Notes	Min	Max	Units	Sub-groups
I_{IB}	Input Bias Current	$\pm V_{CC} = \pm 15V$			1.0	μA	1
		$V_{CC} = 5V$			1.0	μA	1
V_{IO}	Input Offset Voltage	$+V_{CC} = 5V$, $V_{CM} = 1V$, $R_S \leq 5K\Omega$		-4.0	4.0	mV	1
		$+V_{CC} = 5V$, $V_{CM} = 3V$, $R_S \leq 5K\Omega$		-4.0	4.0	mV	1
		$\pm V_{CC} = \pm 15V$, $V_{CM} = 12V$, $R_S \leq 5K\Omega$		-4.0	4.0	mV	1
		$\pm V_{CC} = \pm 15V$, $V_{CM} = -12V$, $R_S \leq 5K\Omega$		-4.0	4.0	mV	1

- (1) Pre and post irradiation limits are identical to those listed under AC and DC electrical characteristics except as listed in the Post Radiation Limits Table. These parts may be dose rate sensitive in a space environment and demonstrate enhanced low dose rate sensitivity. Radiation end point limits for the noted parameters are ensured only for the conditions as specified in MIL-STD-883, per Test Method 1019, Condition A.

LM119 Electrical Characteristics SMD 5962-9679802, ELDRS FREE DC Parameters

The following conditions apply, unless otherwise specified. $V_{CM} = 0V$

Symbol	Parameter	Conditions	Notes	Min	Max	Units	Sub-groups
$+I_{CC}$	Positive Supply Current	$\pm V_{CC} = \pm 15V$, $V_O = \text{Low}$ $V^+ = 5.6V$ thru $1.4K\Omega$			11	mA	1
					11.5	mA	2, 3
$-I_{CC}$	Negative Supply Current	$\pm V_{CC} = \pm 15V$, $V_O = \text{Low}$ $V^+ = 5.6V$ thru $1.4K\Omega$		-4.2		mA	1
				-4.5		mA	2
				-6.0		mA	3
I_{Leak}	Output Leakage Current	$+V_{CC} = 15V$, $-V_{CC} = -1V$, $V_{Gnd} = 0V$, $V_O = 35V$	(1)		1.8	μA	1
			(1)		10	μA	2, 3
I_{IB}	Input Bias Current	$\pm V_{CC} = \pm 15V$			0.47 5	μA	1
					0.95	μA	2, 3
		$+V_{CC} = 5V$	(2)		0.47 5	μA	1
			(2)		.95	μA	2, 3

(1) $V_I \geq 8mV$ at extremes for I_{Leak} and $V_I \leq -8mV$ at extremes for V_{Sat} (V_I to exceed V_{OS}).

(2) 5V differential across $+V_{CC}$ and $-V_{CC}$.

LM119 Electrical Characteristics SMD 5962-9679802, ELDRS FREE DC Parameters (continued)

 The following conditions apply, unless otherwise specified. $V_{CM} = 0V$

Symbol	Parameter	Conditions	Notes	Min	Max	Units	Sub-groups
V_{IO}	Input Offset Voltage	$+V_{CC} = 5V, V_{CM} = 1V, R_S \leq 5K\Omega$	(2)	-3.8	3.8	mV	1
			(2)	-6.8	6.8	mV	2, 3
		$+V_{CC} = 5V, V_{CM} = 3V, R_S \leq 5K\Omega$	(2)	-3.8	3.8	mV	1
			(2)	-6.8	6.8	mV	2, 3
		$\pm V_{CC} = \pm 15V, V_{CM} = 12V, R_S \leq 5K\Omega$		-3.8	3.8	mV	1
				-6.8	6.8	mV	2, 3
I_{IO}	Input Offset Current	$+V_{CC} = 5V, V_{CM} = 1V$	(2)	-75	75	nA	1
			(2)	-100	100	nA	2, 3
		$+V_{CC} = 5V, V_{CM} = 3V$	(2)	-75	75	nA	1
			(2)	-100	100	nA	2, 3
		$\pm V_{CC} = \pm 15V, V_{CM} = 12V$		-75	75	nA	1
				-100	100	nA	2, 3
V_I	Input Voltage Range	$+V_{CC} = 5V$	(3), (3)	1.0	3.0	V	1, 2, 3
			(3)	-12	12	V	1, 2, 3
		$\pm V_{CC} = \pm 15V$	(1)		1.5	V	1, 2, 3
					0.4	V	1, 2
					0.6	V	3
A_V	Voltage Gain	$\pm V_{CC} = \pm 15V, \Delta V_O = 12V, R_L = 1.4K\Omega$	(4)	10.5		K	4
			(4)	10		K	5, 6
		$+V_{CC} = 5V, -V_{CC} = 0V, \Delta V_O = 4.5V, R_L = 1.4K\Omega$	(5), (4)	8.0		K	4
			(5), (4)	5.0		K	5
			(5), (4)	5.8		K	6
CMRR	Common Mode Rejection Ratio	$\pm V_{CC} = \pm 15V, V_{CM} = \pm 12V$		80		dB	4

 (3) Parameter ensured by V_{IO} and I_{IO} tests.

 (4) $K = V/mV$.

 (5) 5V differential across $+V_{CC}$ and $-V_{CC}$.

SMD 5962-9679802, ELDRS FREE DC DELTA Parameters

The following conditions apply, unless otherwise specified.

 $V_{CM} = 0V$, Delta calculations performed on QMLV devices at group B, subgroup 5 only.

Symbol	Parameter	Conditions	Notes	Min	Max	Units	Sub-groups
$+I_{CC}$	Positive Supply Current	$\pm V_{CC} = \pm 15V, V_O = \text{Low}$ $V^+ = 5.6V \text{ thru } 1.4K\Omega$		-1.0	1.0	mA	1
$-I_{CC}$	Negative Supply Current	$\pm V_{CC} = \pm 15V, V_O = \text{Low}$ $V^+ = 5.6V \text{ thru } 1.4K\Omega$		-0.5	0.5	mA	1
V_{IO}	Input Offset Voltage	$+V_{CC} = 5V, V_{CM} = 1V, R_S \leq 5K\Omega$		-0.4	0.4	mV	1

SMD 5962-9679802, ELDRS FREE 100K Post Radiation Parameters @ 25°C ⁽¹⁾

The following conditions apply, unless otherwise specified. $V_{CM} = 0V$

Symbol	Parameter	Conditions	Notes	Min	Max	Units	Sub-groups
I_{IB}	Input Bias Current	$\pm V_{CC} = \pm 15V$			1.0	μA	1
		$V_{CC} = 5V$			1.0	μA	1
V_{IO}	Input Offset Voltage	$+V_{CC} = 5V, V_{CM} = 1V, R_S \leq 5K\Omega$		-4.0	4.0	mV	1
		$+V_{CC} = 5V, V_{CM} = 3V, R_S \leq 5K\Omega$		-4.0	4.0	mV	1
		$\pm V_{CC} = \pm 15V, V_{CM} = 12V, R_S \leq 5K\Omega$		-4.0	4.0	mV	1
		$\pm V_{CC} = \pm 15V, V_{CM} = -12V, R_S \leq 5K\Omega$		-4.0	4.0	mV	1

- (1) Pre and post irradiation limits are identical to those listed under AC and DC electrical characteristics except as listed in the Post Radiation Limits Table. Low dose rate testing has been performed on a wafer-by-wafer basis, per Test Method 1019, Condition D of MIL-STD-883, with no enhanced low dose rate sensitivity (ELDRS).

Typical Performance Characteristics

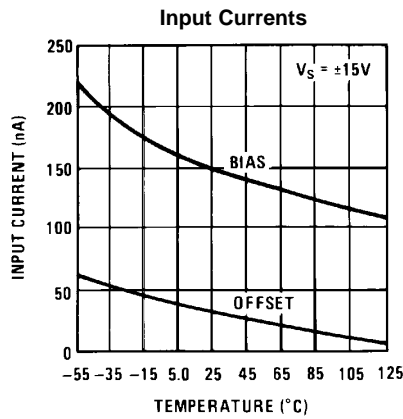

Figure 5.

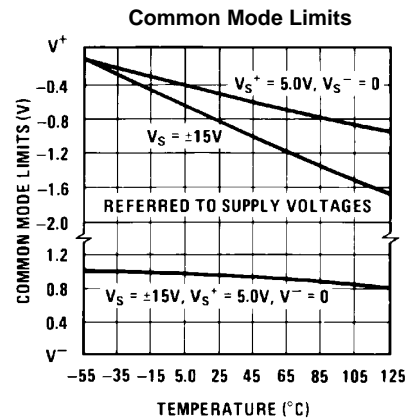

Figure 6.

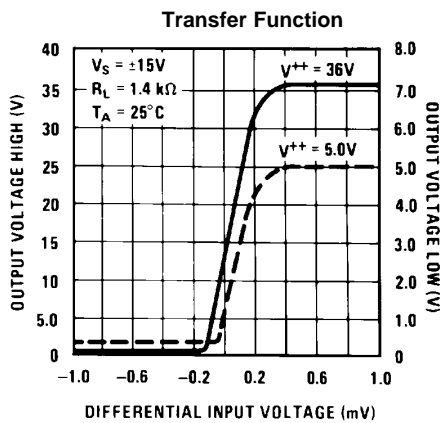

Figure 7.

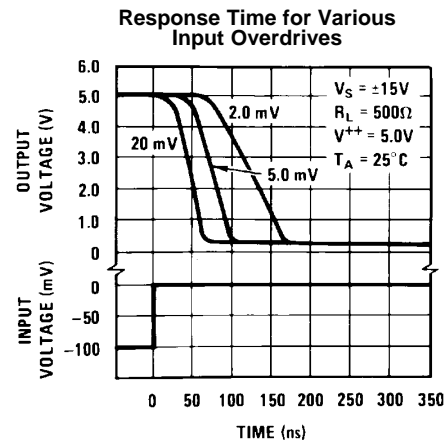

Figure 8.

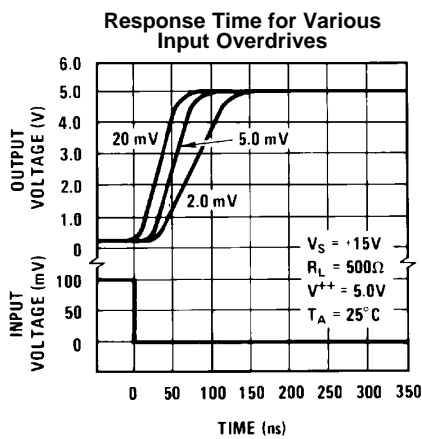

Figure 9.

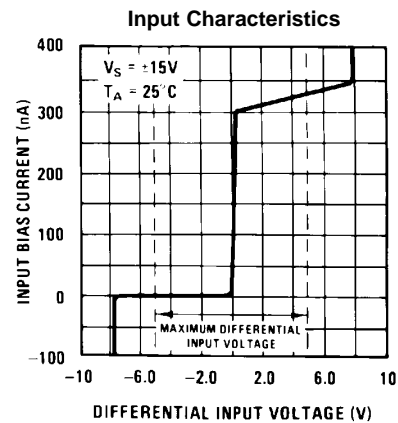

Figure 10.

Typical Performance Characteristics (continued)

Response Time for Various Input Overdrives

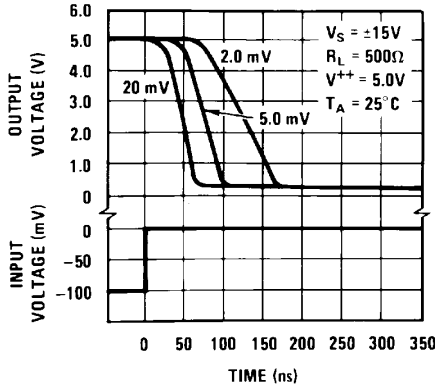

Figure 11.

Response Time for Various Input Overdrives

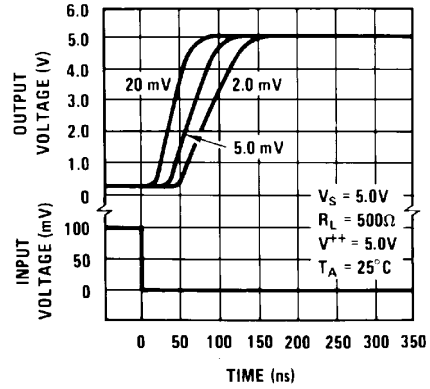

Figure 12.

Output Saturation Voltage

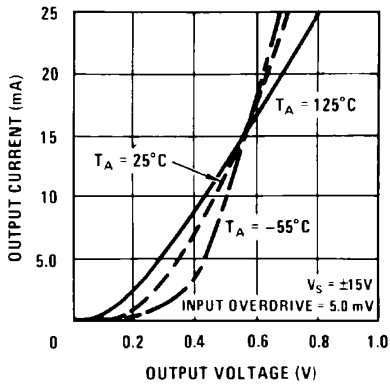

Figure 13.

Supply Current

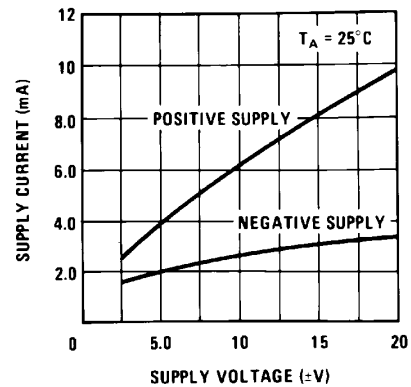

Figure 14.

Supply Current

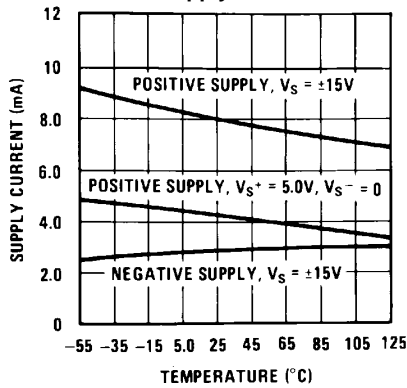

Figure 15.

Output Limiting Characteristics

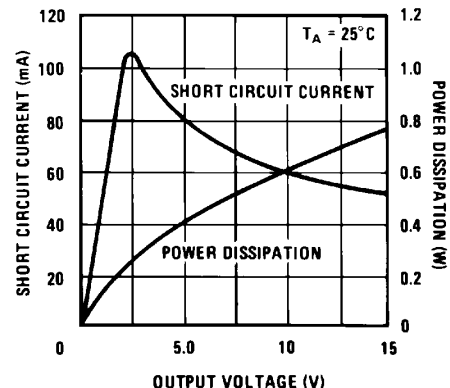
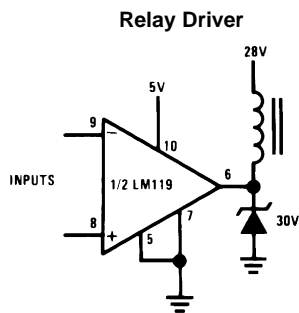
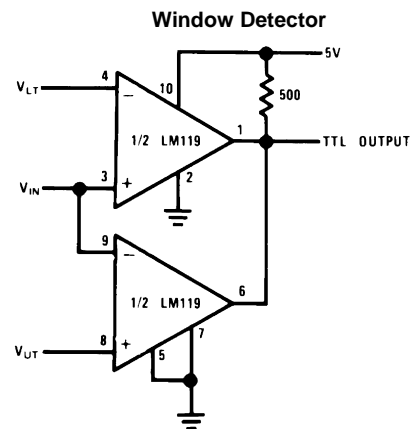

Figure 16.

TYPICAL APPLICATIONS



Pin numbers are for LME0010C package.



$$V_{OUT} = 5V \text{ for } V_{LT} \leq V_{IN} \leq V_{UT}$$

$$V_{OUT} = 0 \text{ for } V_{IN} \leq V_{LT} \text{ or } V_{IN} \geq V_{UT}$$

REVISION HISTORY

Date Released	Revision	Section	Originator	Changes
07/24/08	A	New release to corporate format	L. Lytle	2 MDS datasheets converted into one corporate data sheet format. Added Radiation information. MDS data sheets MNLM119-X Rev. 0F1 & MDLM119-X Rev 2A2 will be archived.
01/13/09	B	Features, Ordering Info., Electrical Section, Notes 13 and 14	Larry McGee	Added reference to ELDRS and Die NSID's to data sheet. Correction from: 100k rd(Si) to 100 krad(Si) in ordering info. Changed wording in Notes 13 and 14 Revision A will be Archived.
03/26/2013	B	All Sections		Changed layout of National Data Sheet to TI format

PACKAGING INFORMATION

Orderable Device	Status (1)	Package Type	Package Drawing	Pins	Package Qty	Eco Plan (2)	Lead/Ball Finish	MSL Peak Temp (3)	Op Temp (°C)	Top-Side Markings (4)	Samples
5962-9679801VCA	ACTIVE	CDIP	J	14	25	TBD	Call TI	Call TI	-55 to 125	LM119J-QMLV 5962-9679801VCA Q	Samples
5962-9679801VIA	ACTIVE	TO-100	LME	10	20	TBD	Call TI	Call TI	-55 to 125	LM119H-QMLV 5962-9679801VIA Q ACO 5962-9679801VIA Q >T	Samples
5962R9679801V9A	ACTIVE	DIESALE	Y	0	32	Green (RoHS & no Sb/Br)	Call TI	Level-1-NA-UNLIM			Samples
5962R9679801VCA	ACTIVE	CDIP	J	14	25	TBD	Call TI	Call TI	-55 to 125	LM119JRQMLV 5962R9679801VCA Q	Samples
5962R9679801VHA	ACTIVE	CFP	NAD	10	19	TBD	Call TI	Call TI	-55 to 125	LM119W RQMLV Q 5962R96798 01VHA ACO 01VHA >T	Samples
5962R9679801VIA	ACTIVE	TO-100	LME	10	20	TBD	Call TI	Call TI	-55 to 125	LM119HRQMLV 5962R9679801VIA Q ACO 5962R9679801VIA Q >T	Samples
5962R9679801VXA	ACTIVE	CFP	NAC	10	54	TBD	Call TI	Call TI	-55 to 125	LM119WG RQMLV Q 5962R96798 01VXA ACO 01VXA >T	Samples
5962R9679802V9A	ACTIVE	DIESALE	Y	0	32	Green (RoHS & no Sb/Br)	Call TI	Level-1-NA-UNLIM			Samples
5962R9679802VCA	ACTIVE	CDIP	J	14	25	TBD	Call TI	Call TI	-55 to 125	LM119JRLQMLV 5962R9679802VCA Q	Samples
5962R9679802VHA	ACTIVE	CFP	NAD	10	19	TBD	Call TI	Call TI	-55 to 125	LM119W RLQMLV Q 5962R96798 02VHA ACO (LM111W ~ LM119W) 02VHA >T	Samples

Orderable Device	Status (1)	Package Type	Package Drawing	Pins	Package Qty	Eco Plan (2)	Lead/Ball Finish	MSL Peak Temp (3)	Op Temp (°C)	Top-Side Markings (4)	Samples
5962R9679802VIA	ACTIVE	TO-100	LME	10	20	TBD	Call TI	Call TI	-55 to 125	LM119HRLQMLV 5962R9679802VIA Q ACO 5962R9679802VIA Q >T	Samples
5962R9679802VXA	ACTIVE	CFP	NAC	10	54	TBD	Call TI	Call TI	-55 to 125	LM119WG RLQMLV Q 5962R96798 02VXA ACO 02VXA >T	Samples
86014012A	ACTIVE	LCCC	NAJ	20	50	TBD	Call TI	Call TI	-55 to 125	LM119E -SMD Q 5962-86014 012A ACO 012A >T	Samples
8601401CA	ACTIVE	CDIP	J	14	25	TBD	Call TI	Call TI	-55 to 125	LM119J-SMD 5962-8601401CA Q	Samples
8601401HA	ACTIVE	CFP	NAD	10	19	TBD	Call TI	Call TI	-55 to 125	LM119W -SMD Q 5962-86014 01HA ACO 01HA >T	Samples
8601401IA	ACTIVE	TO-100	LME	10	20	TBD	Call TI	Call TI	-55 to 125	LM119H-SMD 5962-8601401IA Q A CO 5962-8601401IA Q > T	Samples
LM119 MDE	ACTIVE	DIESALE	Y	0	32	Green (RoHS & no Sb/Br)	Call TI	Level-1-NA-UNLIM			Samples
LM119 MDR	ACTIVE	DIESALE	Y	0	32	Green (RoHS & no Sb/Br)	Call TI	Level-1-NA-UNLIM			Samples
LM119E-SMD	ACTIVE	LCCC	NAJ	20	50	TBD	Call TI	Call TI	-55 to 125	LM119E -SMD Q 5962-86014 012A ACO 012A >T	Samples
LM119E/883	ACTIVE	LCCC	NAJ	20	50	TBD	Call TI	Call TI	-55 to 125	LM119E /883 Q ACO /883 Q >T	Samples

Orderable Device	Status (1)	Package Type	Package Drawing	Pins	Package Qty	Eco Plan (2)	Lead/Ball Finish	MSL Peak Temp (3)	Op Temp (°C)	Top-Side Markings (4)	Samples
LM119H-QMLV	ACTIVE	TO-100	LME	10	20	TBD	Call TI	Call TI	-55 to 125	LM119H-QMLV 5962-9679801VIA Q ACO 5962-9679801VIA Q >T	Samples
LM119H-SMD	ACTIVE	TO-100	LME	10	20	TBD	Call TI	Call TI	-55 to 125	LM119H-SMD 5962-86014011A Q A CO 5962-86014011A Q > T	Samples
LM119H/883	ACTIVE	TO-100	LME	10	20	TBD	Call TI	Call TI	-55 to 125	LM119H/883 Q ACO LM119H/883 Q >T	Samples
LM119HRLQMLV	ACTIVE	TO-100	LME	10	20	TBD	Call TI	Call TI	-55 to 125	LM119HRLQMLV 5962R9679802VIA Q ACO 5962R9679802VIA Q >T	Samples
LM119HRQMLV	ACTIVE	TO-100	LME	10	20	TBD	Call TI	Call TI	-55 to 125	LM119HRQMLV 5962R9679801VIA Q ACO 5962R9679801VIA Q >T	Samples
LM119J-QMLV	ACTIVE	CDIP	J	14	25	TBD	Call TI	Call TI	-55 to 125	LM119J-QMLV 5962-9679801VCA Q	Samples
LM119J-SMD	ACTIVE	CDIP	J	14	25	TBD	Call TI	Call TI	-55 to 125	LM119J-SMD 5962-8601401CA Q	Samples
LM119J/883	ACTIVE	CDIP	J	14	25	TBD	Call TI	Call TI	-25 to 85	LM119J/883 Q	Samples
LM119JRLQMLV	ACTIVE	CDIP	J	14	25	TBD	Call TI	Call TI	-55 to 125	LM119JRLQMLV 5962R9679802VCA Q	Samples
LM119JRQMLV	ACTIVE	CDIP	J	14	25	TBD	Call TI	Call TI	-55 to 125	LM119JRQMLV 5962R9679801VCA Q	Samples
LM119W-SMD	ACTIVE	CFP	NAD	10	19	TBD	Call TI	Call TI	-55 to 125	LM119W -SMD Q 5962-86014 01HA ACO 01HA >T	Samples
LM119W/883	ACTIVE	CFP	NAD	10	19	TBD	Call TI	Call TI	-55 to 125	LM119W /883 Q ACO	Samples

Orderable Device	Status (1)	Package Type	Package Drawing	Pins	Package Qty	Eco Plan (2)	Lead/Ball Finish	MSL Peak Temp (3)	Op Temp (°C)	Top-Side Markings (4)	Samples
										/883 Q >T	
LM119WGRQLMLV	ACTIVE	CFP	NAC	10	54	TBD	Call TI	Call TI	-55 to 125	LM119WG RLQMLV Q 5962R96798 02VXA ACO 02VXA >T	Samples
LM119WGRQMLV	ACTIVE	CFP	NAC	10	54	TBD	Call TI	Call TI	-55 to 125	LM119WG RQMLV Q 5962R96798 01VXA ACO 01VXA >T	Samples
LM119WRLQMLV	ACTIVE	CFP	NAD	10	19	TBD	Call TI	Call TI	-55 to 125	LM119W RLQMLV Q 5962R96798 02VHA ACO (LM111W ~ LM119W) 02VHA >T	Samples
LM119WRQMLV	ACTIVE	CFP	NAD	10	19	TBD	Call TI	Call TI	-55 to 125	LM119W RQMLV Q 5962R96798 01VHA ACO 01VHA >T	Samples

(1) The marketing status values are defined as follows:

ACTIVE: Product device recommended for new designs.

LIFEBUY: TI has announced that the device will be discontinued, and a lifetime-buy period is in effect.

NRND: Not recommended for new designs. Device is in production to support existing customers, but TI does not recommend using this part in a new design.

PREVIEW: Device has been announced but is not in production. Samples may or may not be available.

OBSOLETE: TI has discontinued the production of the device.

(2) Eco Plan - The planned eco-friendly classification: Pb-Free (RoHS), Pb-Free (RoHS Exempt), or Green (RoHS & no Sb/Br) - please check <http://www.ti.com/productcontent> for the latest availability information and additional product content details.

TBD: The Pb-Free/Green conversion plan has not been defined.

Pb-Free (RoHS): TI's terms "Lead-Free" or "Pb-Free" mean semiconductor products that are compatible with the current RoHS requirements for all 6 substances, including the requirement that lead not exceed 0.1% by weight in homogeneous materials. Where designed to be soldered at high temperatures, TI Pb-Free products are suitable for use in specified lead-free processes.

Pb-Free (RoHS Exempt): This component has a RoHS exemption for either 1) lead-based flip-chip solder bumps used between the die and package, or 2) lead-based die adhesive used between the die and leadframe. The component is otherwise considered Pb-Free (RoHS compatible) as defined above.

Green (RoHS & no Sb/Br): TI defines "Green" to mean Pb-Free (RoHS compatible), and free of Bromine (Br) and Antimony (Sb) based flame retardants (Br or Sb do not exceed 0.1% by weight in homogeneous material)

⁽³⁾ MSL, Peak Temp. -- The Moisture Sensitivity Level rating according to the JEDEC industry standard classifications, and peak solder temperature.

⁽⁴⁾ Multiple Top-Side Markings will be inside parentheses. Only one Top-Side Marking contained in parentheses and separated by a "~" will appear on a device. If a line is indented then it is a continuation of the previous line and the two combined represent the entire Top-Side Marking for that device.

Important Information and Disclaimer: The information provided on this page represents TI's knowledge and belief as of the date that it is provided. TI bases its knowledge and belief on information provided by third parties, and makes no representation or warranty as to the accuracy of such information. Efforts are underway to better integrate information from third parties. TI has taken and continues to take reasonable steps to provide representative and accurate information but may not have conducted destructive testing or chemical analysis on incoming materials and chemicals. TI and TI suppliers consider certain information to be proprietary, and thus CAS numbers and other limited information may not be available for release.

In no event shall TI's liability arising out of such information exceed the total purchase price of the TI part(s) at issue in this document sold by TI to Customer on an annual basis.

OTHER QUALIFIED VERSIONS OF LM119QML, LM119QML-SP :

- Military: [LM119QML](#)
- Space: [LM119QML-SP](#)

NOTE: Qualified Version Definitions:

- Military - QML certified for Military and Defense Applications
- Space - Radiation tolerant, ceramic packaging and qualified for use in Space-based application

J (R-GDIP-T**)

14 LEADS SHOWN

CERAMIC DUAL IN-LINE PACKAGE



DIM \ PINS **	14	16	18	20
A	0.300 (7,62) BSC	0.300 (7,62) BSC	0.300 (7,62) BSC	0.300 (7,62) BSC
B MAX	0.785 (19,94)	.840 (21,34)	0.960 (24,38)	1.060 (26,92)
B MIN	—	—	—	—
C MAX	0.300 (7,62)	0.300 (7,62)	0.310 (7,87)	0.300 (7,62)
C MIN	0.245 (6,22)	0.245 (6,22)	0.220 (5,59)	0.245 (6,22)



4040083/F 03/03

- NOTES:
- All linear dimensions are in inches (millimeters).
 - This drawing is subject to change without notice.
 - This package is hermetically sealed with a ceramic lid using glass frit.
 - Index point is provided on cap for terminal identification only on press ceramic glass frit seal only.
 - Falls within MIL STD 1835 GDIP1-T14, GDIP1-T16, GDIP1-T18 and GDIP1-T20.

NAJ0020A

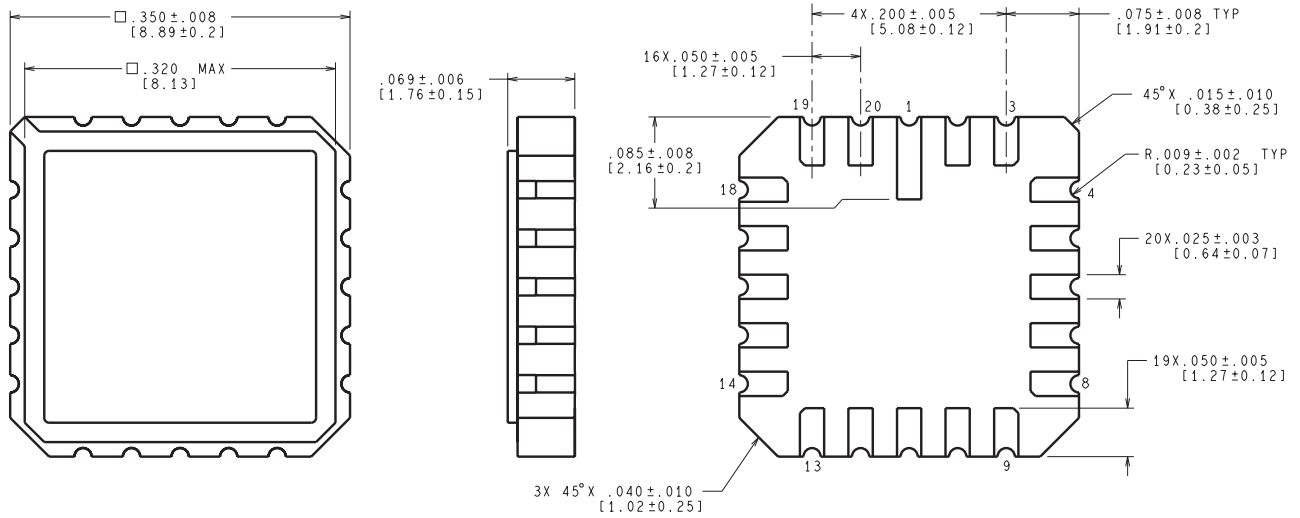

CONTROLLING DIMENSION IS INCH
VALUES IN [] ARE MILLIMETERS

E20A (Rev F)

NAC0010A

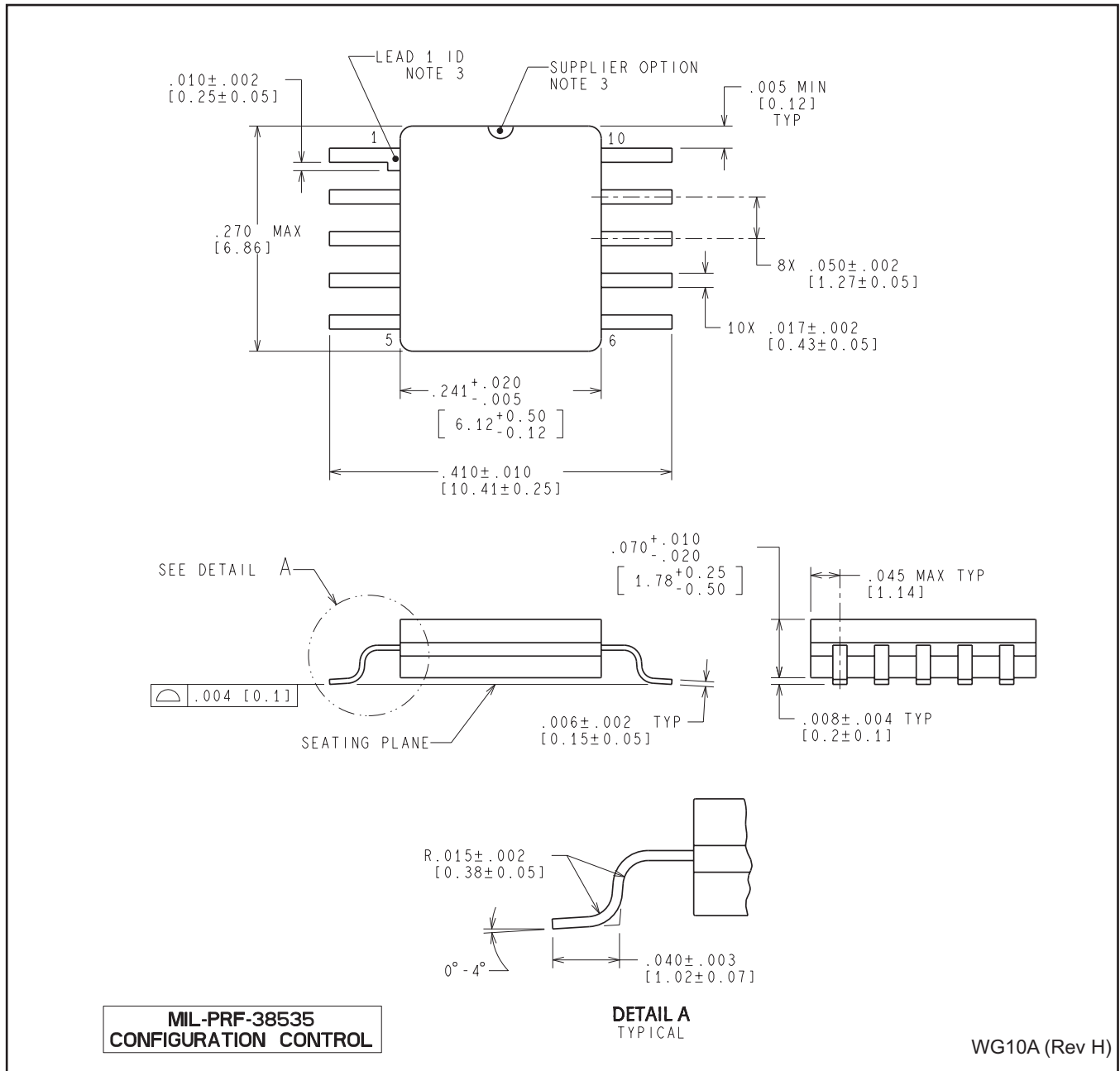

IMPORTANT NOTICE

Texas Instruments Incorporated and its subsidiaries (TI) reserve the right to make corrections, enhancements, improvements and other changes to its semiconductor products and services per JESD46, latest issue, and to discontinue any product or service per JESD48, latest issue. Buyers should obtain the latest relevant information before placing orders and should verify that such information is current and complete. All semiconductor products (also referred to herein as "components") are sold subject to TI's terms and conditions of sale supplied at the time of order acknowledgment.

TI warrants performance of its components to the specifications applicable at the time of sale, in accordance with the warranty in TI's terms and conditions of sale of semiconductor products. Testing and other quality control techniques are used to the extent TI deems necessary to support this warranty. Except where mandated by applicable law, testing of all parameters of each component is not necessarily performed.

TI assumes no liability for applications assistance or the design of Buyers' products. Buyers are responsible for their products and applications using TI components. To minimize the risks associated with Buyers' products and applications, Buyers should provide adequate design and operating safeguards.

TI does not warrant or represent that any license, either express or implied, is granted under any patent right, copyright, mask work right, or other intellectual property right relating to any combination, machine, or process in which TI components or services are used. Information published by TI regarding third-party products or services does not constitute a license to use such products or services or a warranty or endorsement thereof. Use of such information may require a license from a third party under the patents or other intellectual property of the third party, or a license from TI under the patents or other intellectual property of TI.

Reproduction of significant portions of TI information in TI data books or data sheets is permissible only if reproduction is without alteration and is accompanied by all associated warranties, conditions, limitations, and notices. TI is not responsible or liable for such altered documentation. Information of third parties may be subject to additional restrictions.

Resale of TI components or services with statements different from or beyond the parameters stated by TI for that component or service voids all express and any implied warranties for the associated TI component or service and is an unfair and deceptive business practice. TI is not responsible or liable for any such statements.

Buyer acknowledges and agrees that it is solely responsible for compliance with all legal, regulatory and safety-related requirements concerning its products, and any use of TI components in its applications, notwithstanding any applications-related information or support that may be provided by TI. Buyer represents and agrees that it has all the necessary expertise to create and implement safeguards which anticipate dangerous consequences of failures, monitor failures and their consequences, lessen the likelihood of failures that might cause harm and take appropriate remedial actions. Buyer will fully indemnify TI and its representatives against any damages arising out of the use of any TI components in safety-critical applications.

In some cases, TI components may be promoted specifically to facilitate safety-related applications. With such components, TI's goal is to help enable customers to design and create their own end-product solutions that meet applicable functional safety standards and requirements. Nonetheless, such components are subject to these terms.

No TI components are authorized for use in FDA Class III (or similar life-critical medical equipment) unless authorized officers of the parties have executed a special agreement specifically governing such use.

Only those TI components which TI has specifically designated as military grade or "enhanced plastic" are designed and intended for use in military/aerospace applications or environments. Buyer acknowledges and agrees that any military or aerospace use of TI components which have **not** been so designated is solely at the Buyer's risk, and that Buyer is solely responsible for compliance with all legal and regulatory requirements in connection with such use.

TI has specifically designated certain components as meeting ISO/TS16949 requirements, mainly for automotive use. In any case of use of non-designated products, TI will not be responsible for any failure to meet ISO/TS16949.

Products

Audio	www.ti.com/audio
Amplifiers	amplifier.ti.com
Data Converters	dataconverter.ti.com
DLP® Products	www.dlp.com
DSP	dsp.ti.com
Clocks and Timers	www.ti.com/clocks
Interface	interface.ti.com
Logic	logic.ti.com
Power Mgmt	power.ti.com
Microcontrollers	microcontroller.ti.com
RFID	www.ti-rfid.com
OMAP Applications Processors	www.ti.com/omap
Wireless Connectivity	www.ti.com/wirelessconnectivity

Applications

Automotive and Transportation	www.ti.com/automotive
Communications and Telecom	www.ti.com/communications
Computers and Peripherals	www.ti.com/computers
Consumer Electronics	www.ti.com/consumer-apps
Energy and Lighting	www.ti.com/energy
Industrial	www.ti.com/industrial
Medical	www.ti.com/medical
Security	www.ti.com/security
Space, Avionics and Defense	www.ti.com/space-avionics-defense
Video and Imaging	www.ti.com/video

TI E2E Community

e2e.ti.com