

LM119JAN High Speed Dual Comparator

Check for Samples: [LM119JAN](#)

FEATURES

- Two independent comparators
- Operates from a single 5V supply
- Typically 80 ns response time at $\pm 15V$
- Minimum fan-out of 2 each side
- Maximum input current of 1 μA over temperature
- Inputs and outputs can be isolated from system ground
- High common mode slew rate

DESCRIPTION

The LM119 is a precision high speed dual comparator fabricated on a single monolithic chip. It is designed to operate over a wide range of supply voltages down to a single 5V logic supply and ground. Further, it has higher gain and lower input currents than devices such as the LM710. The uncommitted collector of the output stage makes the LM119 compatible with RTL, DTL and TTL as well as capable of driving lamps and relays at currents up to 25 mA.

Although designed primarily for applications requiring operation from digital logic supplies, the LM119 is fully specified for power supplies up to $\pm 15V$. It features faster response than the LM111 at the expense of higher power dissipation. However, the high speed, wide operating voltage range and low package count make the LM119 much more versatile than older devices such as the LM711.

Connection Diagram

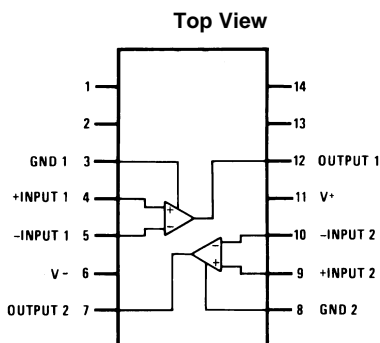
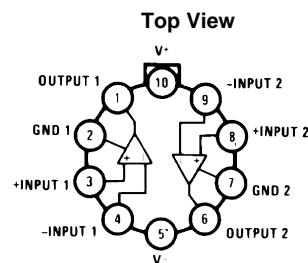

Figure 1. CDIP Package
See Package Number J0014A



Case is connected to pin 5 (V-).

Figure 2. TO-100 Package
See Package Number LME0010C



Please be aware that an important notice concerning availability, standard warranty, and use in critical applications of Texas Instruments semiconductor products and disclaimers thereto appears at the end of this data sheet.

All trademarks are the property of their respective owners.

Schematic Diagram

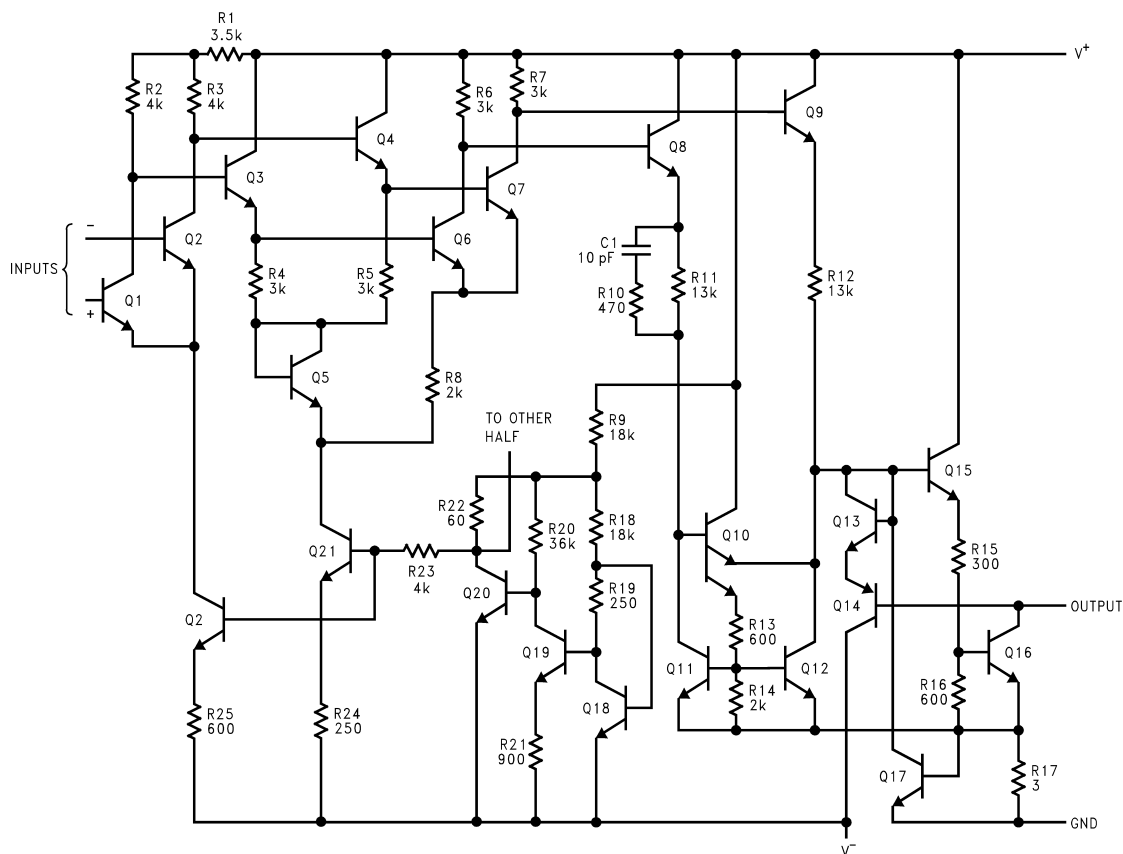

Do not operate the LM119 with more than 16V between GND and V



These devices have limited built-in ESD protection. The leads should be shorted together or the device placed in conductive foam during storage or handling to prevent electrostatic damage to the MOS gates.

Absolute Maximum Ratings ⁽¹⁾

Total Supply Voltage	36V
Output to Negative Supply Voltage	36V
Ground to Negative Supply Voltage	25V
Ground to Positive Supply Voltage	18V
Differential Input Voltage	±5V
Input Voltage ⁽²⁾	±15V
Power Dissipation ⁽³⁾	500 mW
Output Short Circuit Duration	10 sec
Storage Temperature Range	-65°C ≤ T _A ≤ 150°C
Operating Ambient Temperature Range	-55°C ≤ T _A ≤ 125°C
Maximum Junction Temperature (T _J)	150°C
Lead Temperature (Soldering, 10 sec.)	260°C
Thermal Resistance θ_{JA}	
LME0010C Package (Still Air)	162°C/W
LME0010C Package (500LF/Min Air flow)	88°C/W
J0014A Package (Still Air)	94°C/W
J0014A Package (500LF/Min Air flow)	52°C/W
Thermal Resistance θ_{JC}	
LME0010C Package	31°C/W
J0014A Package	11°C/W
Package Weight	
LME0010C Package, J0014A Package	TBD
ESD rating ⁽⁴⁾	800V

- (1) Absolute Maximum Ratings indicate limits beyond which damage to the device may occur. Operating Ratings indicate conditions for which the device is functional, but do not ensure specific performance limits. For ensured specifications and test conditions, see the Electrical Characteristics. The ensured specifications apply only for the test conditions listed. Some performance characteristics may degrade when the device is not operated under the listed test conditions.
- (2) For supply voltages less than ±15V the absolute maximum input voltage is equal to the supply voltage.
- (3) The maximum power dissipation must be derated at elevated temperatures and is dictated by T_{Jmax} (maximum junction temperature), θ_{JA} (package junction to ambient thermal resistance), and T_A (ambient temperature). The maximum allowable power dissipation at any temperature is P_{Dmax} = (T_{Jmax} - T_A)/ θ_{JA} or the number given in the Absolute Maximum Ratings, whichever is lower.
- (4) Human Body model, 1.5K Ω in series with 100pF.

Table 1. Quality Conformance Inspection ⁽¹⁾

Subgroup	Description	Temp °C
1	Static tests at	25
2	Static tests at	125
3	Static tests at	-55
4	Dynamic tests at	25
5	Dynamic tests at	125
6	Dynamic tests at	-55
7	Functional tests at	25
8A	Functional tests at	125
8B	Functional tests at	-55
9	Switching tests at	25
10	Switching tests at	125
11	Switching tests at	-55
12	Settling time at	25
13	Settling time at	125
14	Settling time at	-55

- (1) Mil-Std-883, Method 5005 - Group A

Electrical Characteristics DC Parameters

Symbol	Parameter	Conditions	Notes	Min	Max	Unit	Sub-groups
V_{IO}	Input Offset Voltage	$+V_{CC} = 15V, -V_{CC} = -15V,$ $V_{CM} = 0V, R_S = 50\Omega$		-4.0	4.0	mV	1
				-7.0	7.0	mV	2, 3
		$+V_{CC} = 27V, -V_{CC} = -3V,$ $V_{CM} = -12V, R_S = 50\Omega$		-4.0	4.0	mV	1
				-7.0	7.0	mV	2, 3
		$+V_{CC} = 3V, -V_{CC} = -27V,$ $V_{CM} = 12V, R_S = 50\Omega$		-4.0	4.0	mV	1
		-7.0	7.0	mV	2, 3		
I_{IO}	Input Offset Current	$+V_{CC} = 15V, -V_{CC} = -15V,$ $V_{CM} = 0V$		-75	+75	nA	1, 2
				-100	+100	nA	3
		$+V_{CC} = 27V, -V_{CC} = -3V,$ $V_{CM} = -12V$		-75	+75	nA	1, 2
				-100	+100	nA	3
		$+V_{CC} = 3V, -V_{CC} = -27V,$ $V_{CM} = 12V$		-75	+75	nA	1, 2
		-100	+100	nA	3		
$+I_{CC}$	Power Supply Current	$+V_{CC} = 15V, -V_{CC} = -15V$			10	mA	1, 2
					11.5	mA	3
$-I_{CC}$	Power Supply Current	$+V_{CC} = 15V, -V_{CC} = -15V$		-5.0		mA	1
				-4.5		mA	2
				-6.0		mA	3
$\pm I_{IB}$	Input Bias Current	$+V_{CC} = 15V, -V_{CC} = -15V,$ $V_{CM} = 0V$		-0.1	500	nA	1, 2
				-0.1	1000	nA	3
		$+V_{CC} = 27V, -V_{CC} = -3V,$ $V_{CM} = -12V$		-0.1	750	nA	1, 2
				-0.1	1000	nA	3
		$+V_{CC} = 3V, -V_{CC} = -27V,$ $V_{CM} = 12V$		-0.1	750	nA	1, 2
		-0.1	1000	nA	3		
CMRR	Common Mode Rejection	$-12V \leq V_{CM} \leq +12V,$ $-27V \leq -V_{CC} \leq -3V,$ $3V \leq +V_{CC} \leq 27V, R_S = 50\Omega$		90		dB	1, 2, 3
V_{OL}	Low Level Output Voltage	$+V_{CC} = 3.5V, -V_{CC} = -1V,$ $V_{CM} = 1V, V_{IO} = 7mV,$ $I_O = 3.2mA$			0.4	V	1, 2
					0.6	V	3
		$+V_{CC} = 2.25V, -V_{CC} = -2.25V,$ $V_{CM} = 2.25V, V_{IO} = 7mV,$ $I_O = 3.2mA$			0.4	V	1, 2
					0.6	V	3
		$+V_{CC} = 27V, -V_{CC} = -3V,$ $V_{CM} = -12V, V_{IO} = 7mV,$ $I_O = 25mA$			1.5	V	1, 2, 3
$+V_{CC} = 3V, -V_{CC} = -27V,$ $V_{CM} = 12V, V_{IO} = 7mV,$ $I_O = 25mA$			1.5	V	1, 2, 3		
I_{CEX}	Output Leakage Current	$+V_{CC} = 18V, -V_{CC} = -18V,$ $V_O = 18V$		-1.0	2.0	μA	1
				-1.0	10	μA	2
A_V	Voltage Gain (Collector)	$+V_{CC} = 15V, -V_{CC} = -15V,$ $V_O = 1.5V \text{ to } 11.5V$	(1)	10		K	4
			(1)	5.0		K	5, 6

(1) K = V/mV.

Electrical Characteristics AC Parameters

The following conditions apply to all the following parameters, unless otherwise specified.

AC: $\pm 15V$, $C_L = 50pF$

Symbol	Parameter	Conditions	Notes	Min	Max	Unit	Sub-groups
$t_{R_{LHC}}$	Response Time (Collector Output)	V_{OD} (overdrive) = +5mV, $V_I = 100mV$			125	nS	9
$t_{R_{HLC}}$	Response Time (Collector Output)	V_{OD} (overdrive) = -5mV, $V_I = 100mV$			160	nS	9

Electrical Characteristics DC Drift Parameters

Delta calculations performed at Group B-5

Symbol	Parameter	Conditions	Notes	Min	Max	Unit	Sub-groups
V_{IO}	Input Offset Voltage	$+V_{CC} = 15V$, $-V_{CC} = -15V$, $V_{CM} = 0V$, $R_S = 50\Omega$		-1.0	1.0	mV	1
		$+V_{CC} = 27V$, $-V_{CC} = -3V$, $V_{CM} = -12V$, $R_S = 50\Omega$		-1.0	1.0	mV	1
		$+V_{CC} = 3V$, $-V_{CC} = -27V$, $V_{CM} = 12V$, $R_S = 50\Omega$		-1.0	1.0	mV	1
$\pm I_{IB}$	Input Bias Current	$+V_{CC} = 15V$, $-V_{CC} = -15V$, $V_{CM} = 0V$		-50	50	nA	1
		$+V_{CC} = 27V$, $-V_{CC} = -3V$, $V_{CM} = -12V$		-50	50	nA	1
		$+V_{CC} = 3V$, $-V_{CC} = -27V$, $V_{CM} = 12V$		-50	50	nA	1

Typical Performance Characteristics

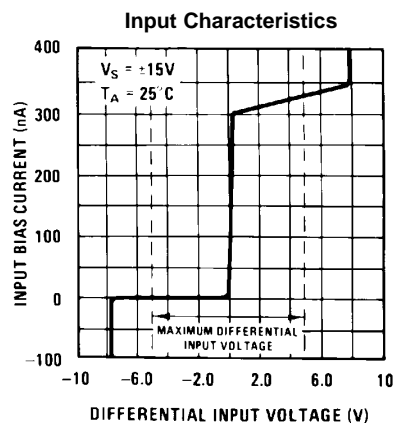
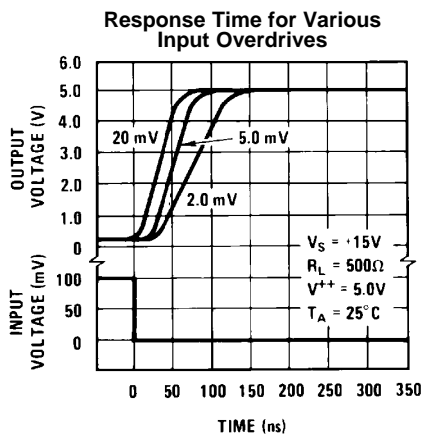
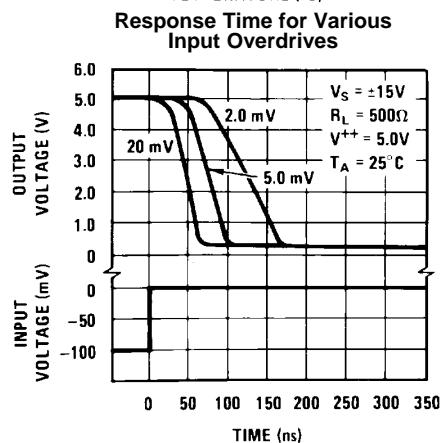
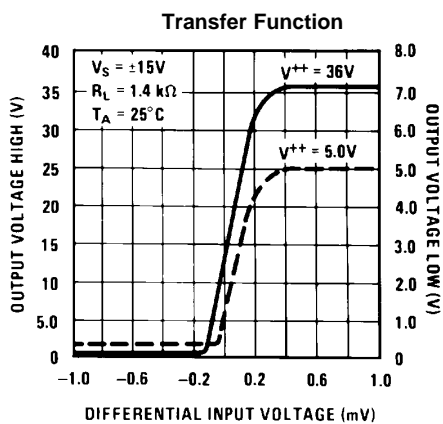
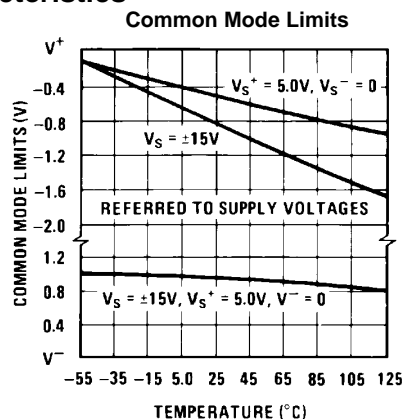
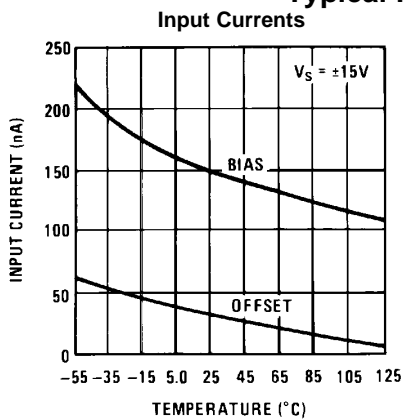

Typical Performance Characteristics (continued)

Response Time for Various Input Overdrives

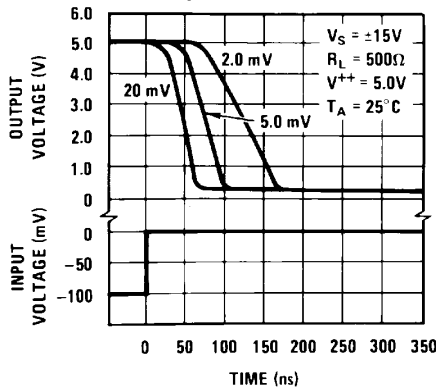

Response Time for Various Input Overdrives

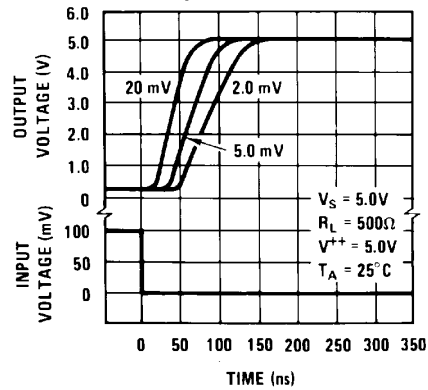

Output Saturation Voltage

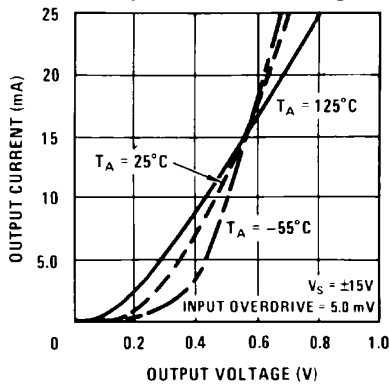

Supply Current

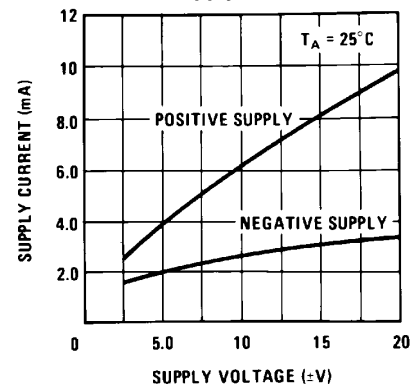

Supply Current

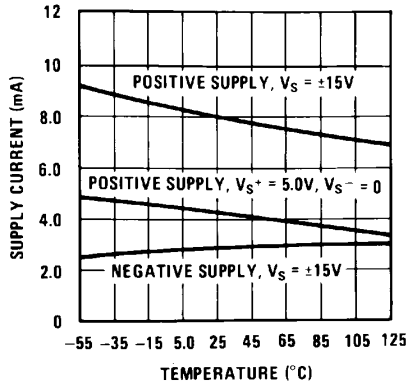

Output Limiting Characteristics

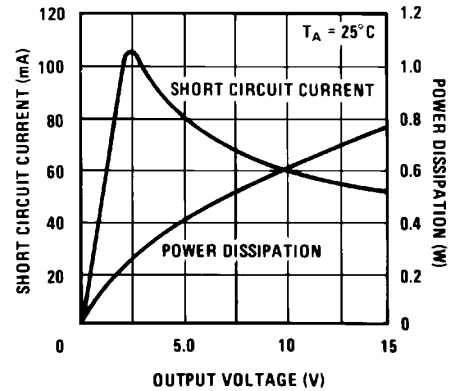

TYPICAL APPLICATIONS

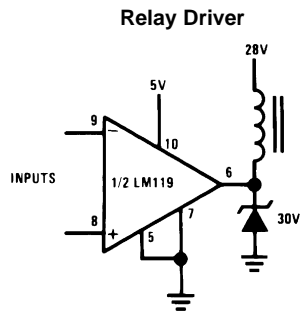

Pin numbers are for TO-100 package.

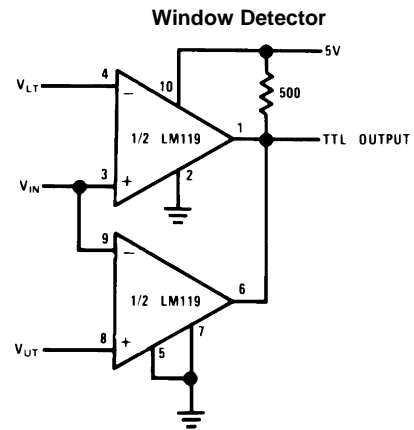

$$V_{OUT} = 5V \text{ for } V_{LT} \leq V_{IN} \leq V_{UT}$$

$$V_{OUT} = 0 \text{ for } V_{IN} \leq V_{LT} \text{ or } V_{IN} \geq V_{UT}$$

REVISION HISTORY

Date Released	Revision	Section	Changes
7/0105	A	New release to corporate format	1 MDS datasheet converted into one corporate data sheet format MJLM119-X Rev. OBL will be archived.
09/24/2010	B	Obsolete Data Sheet	Revision B, End of Life on Product/NSID Dec. 2009 Obsolete Data Sheet

Changes from Revision A (April 2013) to Revision B
Page

- Changed layout of National Data Sheet to TI format **8**

IMPORTANT NOTICE

Texas Instruments Incorporated and its subsidiaries (TI) reserve the right to make corrections, enhancements, improvements and other changes to its semiconductor products and services per JESD46, latest issue, and to discontinue any product or service per JESD48, latest issue. Buyers should obtain the latest relevant information before placing orders and should verify that such information is current and complete. All semiconductor products (also referred to herein as "components") are sold subject to TI's terms and conditions of sale supplied at the time of order acknowledgment.

TI warrants performance of its components to the specifications applicable at the time of sale, in accordance with the warranty in TI's terms and conditions of sale of semiconductor products. Testing and other quality control techniques are used to the extent TI deems necessary to support this warranty. Except where mandated by applicable law, testing of all parameters of each component is not necessarily performed.

TI assumes no liability for applications assistance or the design of Buyers' products. Buyers are responsible for their products and applications using TI components. To minimize the risks associated with Buyers' products and applications, Buyers should provide adequate design and operating safeguards.

TI does not warrant or represent that any license, either express or implied, is granted under any patent right, copyright, mask work right, or other intellectual property right relating to any combination, machine, or process in which TI components or services are used. Information published by TI regarding third-party products or services does not constitute a license to use such products or services or a warranty or endorsement thereof. Use of such information may require a license from a third party under the patents or other intellectual property of the third party, or a license from TI under the patents or other intellectual property of TI.

Reproduction of significant portions of TI information in TI data books or data sheets is permissible only if reproduction is without alteration and is accompanied by all associated warranties, conditions, limitations, and notices. TI is not responsible or liable for such altered documentation. Information of third parties may be subject to additional restrictions.

Resale of TI components or services with statements different from or beyond the parameters stated by TI for that component or service voids all express and any implied warranties for the associated TI component or service and is an unfair and deceptive business practice. TI is not responsible or liable for any such statements.

Buyer acknowledges and agrees that it is solely responsible for compliance with all legal, regulatory and safety-related requirements concerning its products, and any use of TI components in its applications, notwithstanding any applications-related information or support that may be provided by TI. Buyer represents and agrees that it has all the necessary expertise to create and implement safeguards which anticipate dangerous consequences of failures, monitor failures and their consequences, lessen the likelihood of failures that might cause harm and take appropriate remedial actions. Buyer will fully indemnify TI and its representatives against any damages arising out of the use of any TI components in safety-critical applications.

In some cases, TI components may be promoted specifically to facilitate safety-related applications. With such components, TI's goal is to help enable customers to design and create their own end-product solutions that meet applicable functional safety standards and requirements. Nonetheless, such components are subject to these terms.

No TI components are authorized for use in FDA Class III (or similar life-critical medical equipment) unless authorized officers of the parties have executed a special agreement specifically governing such use.

Only those TI components which TI has specifically designated as military grade or "enhanced plastic" are designed and intended for use in military/aerospace applications or environments. Buyer acknowledges and agrees that any military or aerospace use of TI components which have **not** been so designated is solely at the Buyer's risk, and that Buyer is solely responsible for compliance with all legal and regulatory requirements in connection with such use.

TI has specifically designated certain components as meeting ISO/TS16949 requirements, mainly for automotive use. In any case of use of non-designated products, TI will not be responsible for any failure to meet ISO/TS16949.

Products

Audio	www.ti.com/audio
Amplifiers	amplifier.ti.com
Data Converters	dataconverter.ti.com
DLP® Products	www.dlp.com
DSP	dsp.ti.com
Clocks and Timers	www.ti.com/clocks
Interface	interface.ti.com
Logic	logic.ti.com
Power Mgmt	power.ti.com
Microcontrollers	microcontroller.ti.com
RFID	www.ti-rfid.com
OMAP Applications Processors	www.ti.com/omap
Wireless Connectivity	www.ti.com/wirelessconnectivity

Applications

Automotive and Transportation	www.ti.com/automotive
Communications and Telecom	www.ti.com/communications
Computers and Peripherals	www.ti.com/computers
Consumer Electronics	www.ti.com/consumer-apps
Energy and Lighting	www.ti.com/energy
Industrial	www.ti.com/industrial
Medical	www.ti.com/medical
Security	www.ti.com/security
Space, Avionics and Defense	www.ti.com/space-avionics-defense
Video and Imaging	www.ti.com/video

TI E2E Community

e2e.ti.com