

1.7 GHz, Ultra Low Distortion, Wideband Op Amp

Check for Samples: [LMH6702QML](#)

FEATURES

- $V_S = \pm 5V$, $T_A = 25^\circ C$, $A_V = +2V/V$, $R_L = 100\Omega$, $V_{OUT} = 2V_{PP}$, Typical Unless Noted:
- Available with Radiation Ensurance
 - High Dose Rate 300 krad(Si)
 - ELDRS Free 300 krad(Si)
- –3dB Bandwidth ($V_{OUT} = 0.2 V_{PP}$) 720 MHz
- Low Noise $1.83nV/\sqrt{Hz}$
- Fast Settling to 0.1% 13.4ns
- Fast Slew Rate 3100V/ μs
- Supply Current 12.5mA
- Output Current 80mA
- Low Intermodulation Distortion (75MHz) –67dBc
- Improved Replacement for CLC409 and CLC449

APPLICATIONS

- Flash A/D Driver
- D/A transimpedance Buffer
- Wide Dynamic Range IF Amp
- Radar/Communication Receivers
- Line Driver
- High Resolution Video

Connection Diagrams

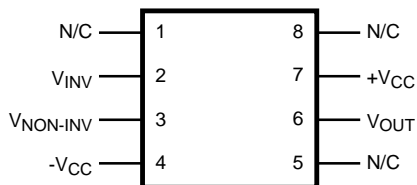

**Figure 1. 8-Lead CDIP (NAB)
Top View**

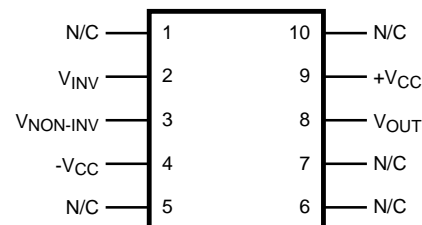

**Figure 2. 10-Lead CLGA (NAC)
Top View**



These devices have limited built-in ESD protection. The leads should be shorted together or the device placed in conductive foam during storage or handling to prevent electrostatic damage to the MOS gates.



Please be aware that an important notice concerning availability, standard warranty, and use in critical applications of Texas Instruments semiconductor products and disclaimers thereto appears at the end of this data sheet.

All trademarks are the property of their respective owners.

Absolute Maximum Ratings⁽¹⁾

Supply Voltage (V_{CC})	$\pm 6.75V_{DC}$
Common Mode Input Voltage (V_{CM})	V to V^+
Power Dissipation (P_D) ⁽²⁾	1W
Junction Temperature (T_J)	+175°C
Lead Temperature (soldering, 10 seconds)	+300°C
Storage Temperature Range	$-65^\circ\text{C} \leq T_A \leq +150^\circ\text{C}$
Thermal Resistance	
θ_{JA}	
CDIP (Still Air)	170°C/W
CDIP (500LF/Min Air Flow)	100°C/W
CLGA (Still Air)	220°C/W
CLGA (500LF/Min Air Flow)	150°C/W
θ_{JC}	
CDIP	35°C/W
CLGA	37°C/W
Package Weight (Typical)	
CDIP	1078mg
CLGA	227mg
ESD Tolerance ⁽³⁾	1000V

- (1) Absolute Maximum Ratings are limits beyond which damage to the device may occur. Operating Ratings are conditions for which the device is functional, but do not ensure specific performance limits. For ensured specifications and test conditions see the Electrical Characteristics. The ensured specifications apply only for the test conditions listed. Some performance characteristics may degrade when the device is not operated under the listed test conditions.
- (2) The maximum power dissipation must be derated at elevated temperatures and is dictated by T_{Jmax} (maximum junction temperature), θ_{JA} (package junction to ambient thermal resistance), and T_A (ambient temperature). The maximum allowable power dissipation at any temperature is $P_{Dmax} = (T_{Jmax} - T_A)/\theta_{JA}$ or the number given in the Absolute Maximum Ratings, whichever is lower.
- (3) Human body model, 1.5k Ω in series with 100pF.

Recommended Operating Conditions

Supply Voltage (V_{CC})	$\pm 5V_{DC}$ to $\pm 6V_{DC}$
Gain Range	± 1 to ± 10
Ambient Operating Temperature Range (T_A)	-55°C to $+125^\circ\text{C}$

Quality Conformance Inspection

MIL-STD-883, Method 5005, Group A

Subgroup	Description	Temp (C)
1	Static tests at	+25
2	Static tests at	+125
3	Static tests at	-55
4	Dynamic tests at	+25
5	Dynamic tests at	+125
6	Dynamic tests at	-55
7	Functional tests at	+25
8A	Functional tests at	+125
8B	Functional tests at	-55
9	Switching tests at	+25
10	Switching tests at	+125
11	Switching tests at	-55

LMH6702 Electrical Characteristics DC Parameters ⁽¹⁾⁽²⁾

The following conditions apply, unless otherwise specified.

$R_L = 100\Omega$, $V_{CC} = \pm 5V_{DC}$, $A_V = +2$ feedback resistor (R_F) = 250 Ω , gain resistor (R_G) = 250 Ω

Symbol	Parameter	Conditions	Notes	Min	Max	Unit	Sub-groups
I_{BN}	Input Bias Current, Noninverting			-15	+15	μA	1, 2
				-21	+21	μA	3
I_{BI}	Input Bias Current, Inverting			-30	+30	μA	1, 2
				-34	+34	μA	3
V_{IO}	Input Offset Voltage			-4.5	+4.5	mV	1, 3
				-6.0	+6.0	mV	2
I_{CC}	Supply Current, no load	$R_L = \infty$			15	mA	1, 2, 3
PSSR	Power Supply Rejection Ratio	$-V_{CC} = -4.5V$ to $-5.0V$, $+V_{CC} = +4.5V$ to $+5.0V$		45		dB	1, 2, 3

- (1) The algebraic convention, whereby the most negative value is a minimum and most positive is a maximum, is used in this table. Negative current shall be defined as conventional current flow out of a device terminal.
- (2) Pre and Post irradiation limits are identical to those listed under the DC parameter tables above. Post irradiation testing is conducted at room temperature, +25°C, only. Testing is performed as specified in MIL-STD-883 Test Method 1019 Condition A. The ELDRS-Free part is also tested per Test Method 1019 Conditions D.

LMH6702 Electrical Characteristics AC Parameters ⁽¹⁾⁽²⁾

The following conditions apply, unless otherwise specified.

$R_L = 100\Omega$, $V_{CC} = \pm 5V_{DC}$, $A_V = +2$ feedback resistor (R_F) = 250 Ω , gain resistor (R_G) = 250 Ω

Symbol	Parameter	Conditions	Notes	Min	Max	Unit	Sub-groups
HD_3	3rd Harmonic Distortion	$2V_{PP}$ at 20MHz			-62	dBc	4
GFPL	Gain Flatness Peaking	0.1MHz to 75MHz, $V_O < 0.5V_{PP}$			0.4	dB	4
GFPH	Gain Flatness Peaking	> 75MHz, $V_O < 0.5V_{PP}$			2.0	dB	4
GFRH	Gain Flatness Rolloff	75MHz to 125MHz, $V_O < 0.5V_{PP}$			0.2	dB	4
HD_2	2nd Harmonic Distortion	$2V_{PP}$ at 20MHz			-52	dBc	4

- (1) The algebraic convention, whereby the most negative value is a minimum and most positive is a maximum, is used in this table. Negative current shall be defined as conventional current flow out of a device terminal.
- (2) These parameters are not post irradiation tested.

LMH6702 Electrical Characteristics Drift Values Parameters⁽¹⁾

The following conditions apply, unless otherwise specified.

$R_L = 100\Omega$, $V_{CC} = \pm 5V_{DC}$, $A_V = +2$ feedback resistor (R_F) = 250 Ω , gain resistor (R_G) = 250 Ω

"Delta not required on B level product. Delta required for S-level product at Group B5 only, or as specified on the Internal Processing Instruction (IPI)."

Symbol	Parameter	Conditions	Notes	Min	Max	Unit	Sub-groups
I_{BN}	Input Bias Current Noninverting			-0.3	+0.3	μA	1
I_{BI}	Input Bias Current Inverting			-3.0	+3.0	μA	1
V_{IO}	Input Offset Voltage			-0.3	+0.3	mV	1

- (1) The algebraic convention, whereby the most negative value is a minimum and most positive is a maximum, is used in this table. Negative current shall be defined as conventional current flow out of a device terminal.

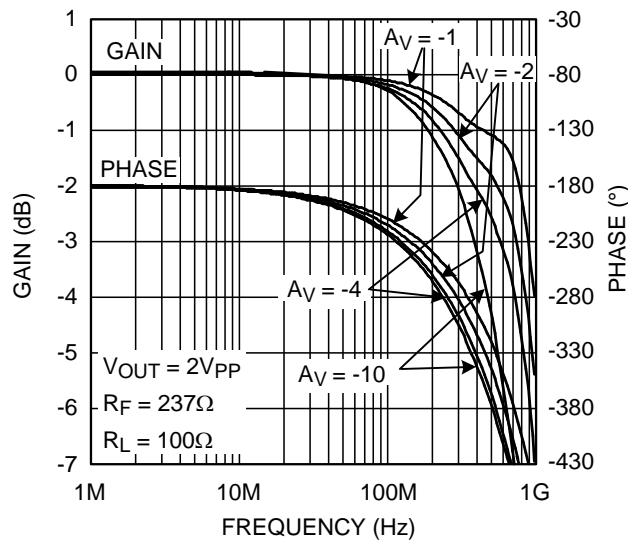

Figure 3. Inverting Frequency Response

Typical Performance Characteristics

($T_A = 25^\circ\text{C}$, $V_S = \pm 5\text{V}$, $R_L = 100\Omega$, $R_F = 237\Omega$; Unless Specified).

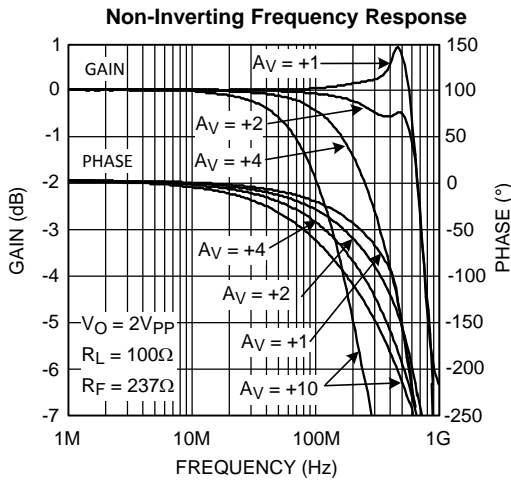

Figure 4.

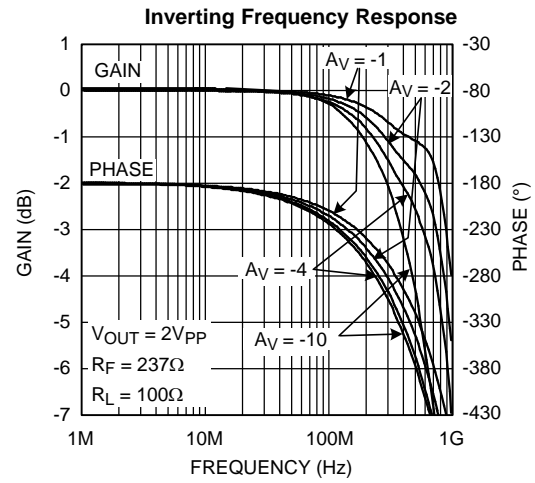

Figure 5.

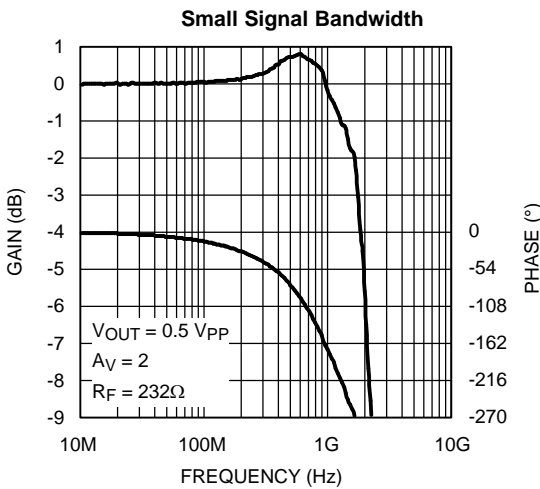

Figure 6.

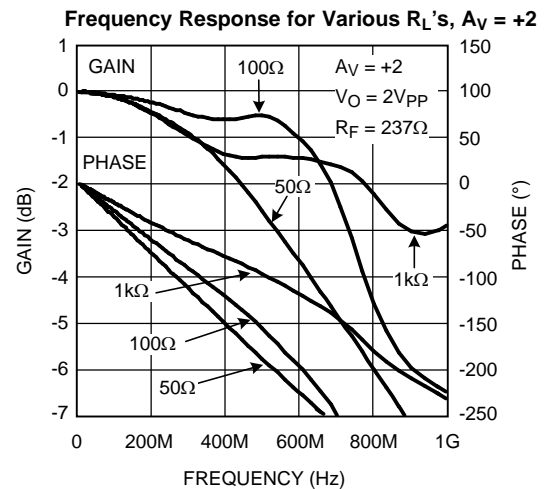

Figure 7.

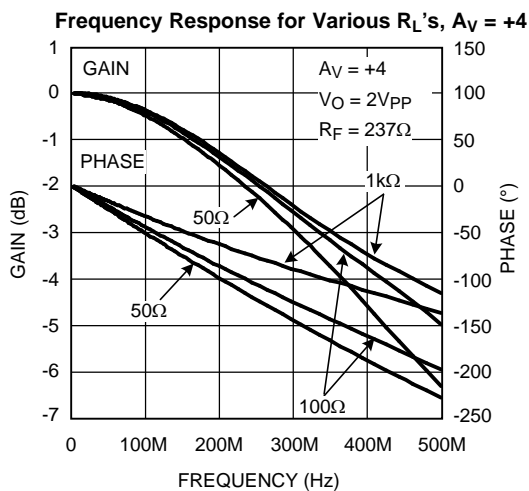

Figure 8.

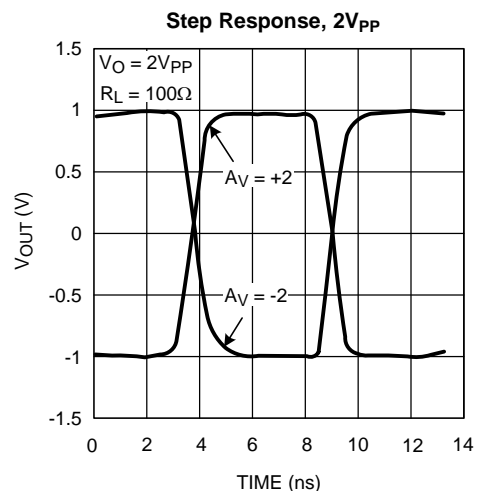

Figure 9.

Typical Performance Characteristics (continued)

($T_A = 25^\circ\text{C}$, $V_S = \pm 5\text{V}$, $R_L = 100\Omega$, $R_F = 237\Omega$; Unless Specified).

Step Response, 6V_{PP}

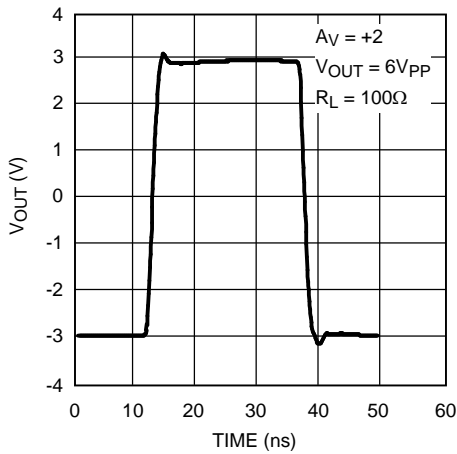

Figure 10.

Percent Settling vs. Time

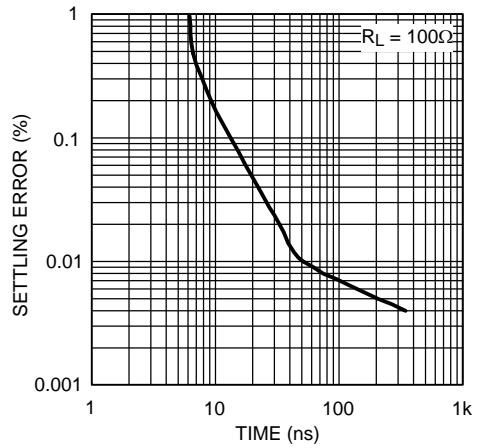

Figure 11.

R_S and Settling Time vs. C_L

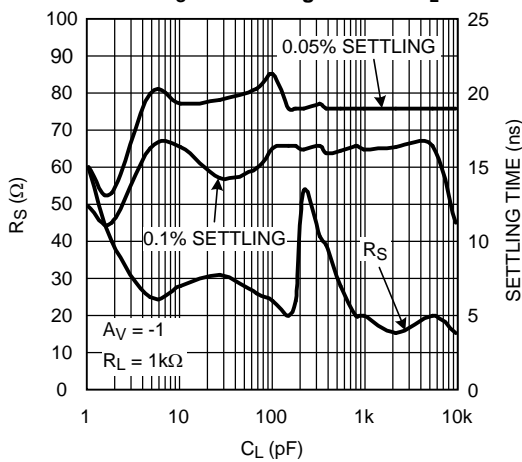

Figure 12.

Input Offset for 3 Representative Units

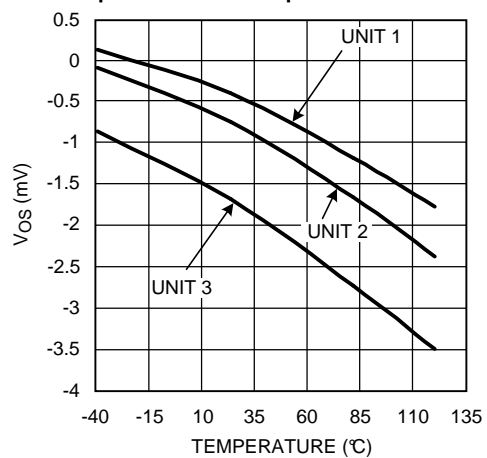

Figure 13.

Inverting Input Bias for 3 Representative Units

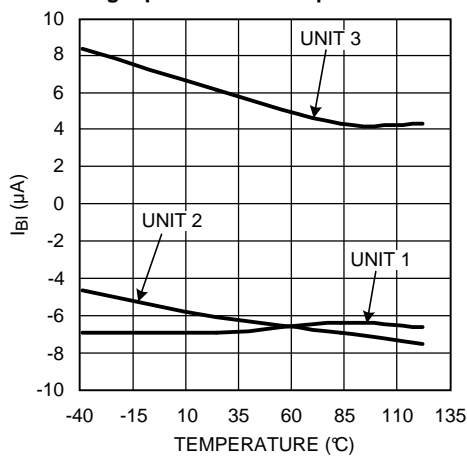

Figure 14.

Non-Inverting Input Bias for 3 Representative Units

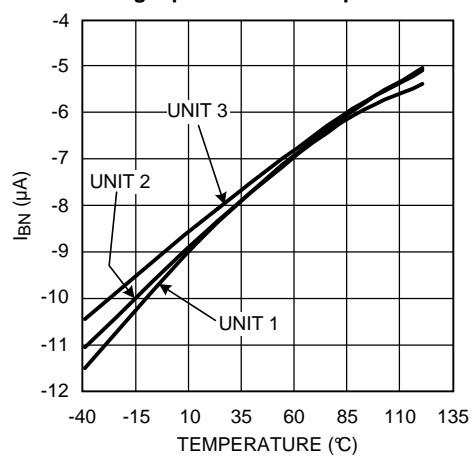

Figure 15.

Typical Performance Characteristics (continued)

($T_A = 25^\circ\text{C}$, $V_S = \pm 5\text{V}$, $R_L = 100\Omega$, $R_F = 237\Omega$; Unless Specified).

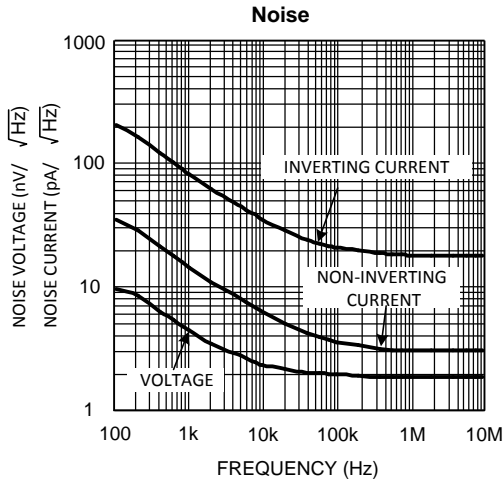

Figure 16.

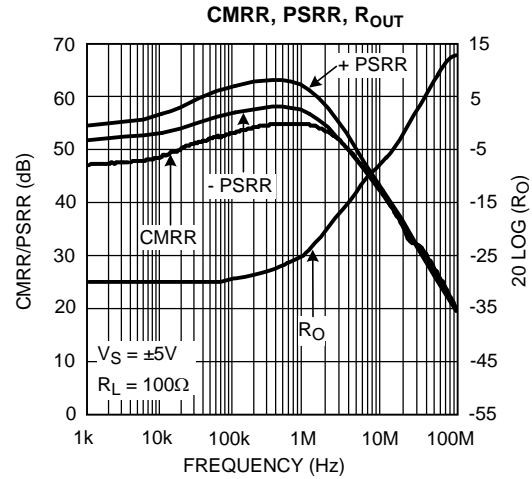

Figure 17.

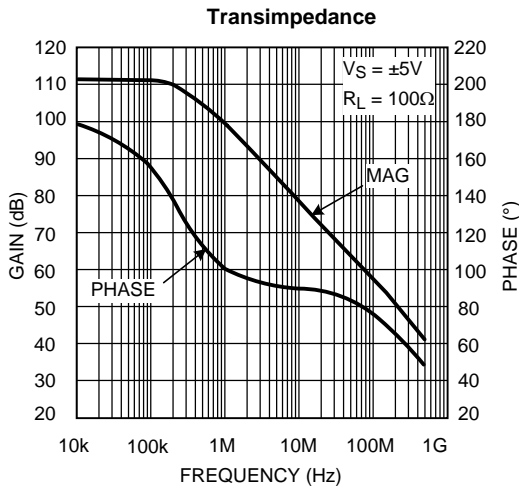

Figure 18.

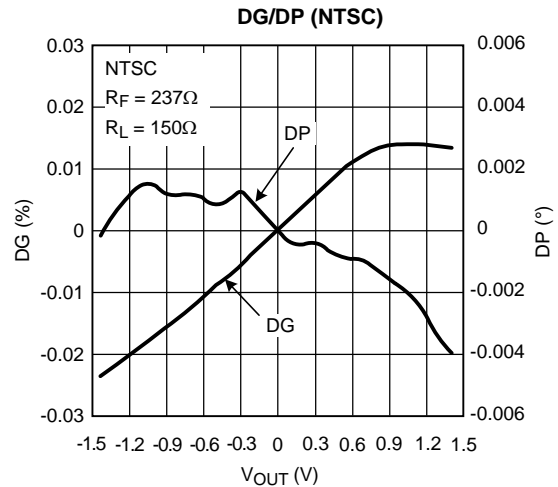

Figure 19.

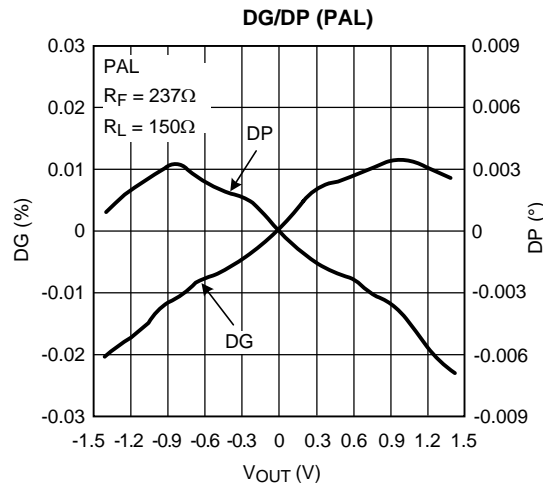

Figure 20.

APPLICATION SECTION

FEEDBACK RESISTOR

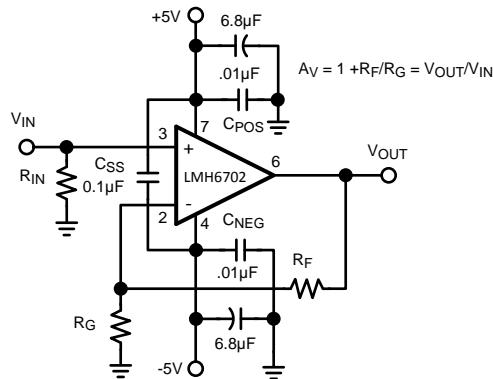

Figure 21. Recommended Non-Inverting Gain Circuit

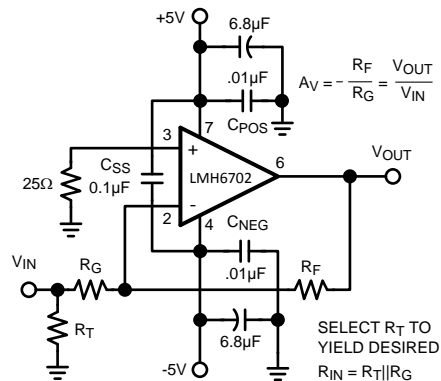

Figure 22. Recommended Inverting Gain Circuit

The LMH6702 achieves its excellent pulse and distortion performance by using the current feedback topology. The loop gain for a current feedback op amp, and hence the frequency response, is predominantly set by the feedback resistor value. The LMH6702 is optimized for use with a 237Ω feedback resistor. Using lower values can lead to excessive ringing in the pulse response while a higher value will limit the bandwidth. Application Note OA-13 [SNOA366](#) discusses this in detail along with the occasions where a different R_F might be advantageous.

HARMONIC DISTORTION

The LMH6702 has been optimized for exceptionally low harmonic distortion while driving very demanding resistive or capacitive loads. Generally, when used as the input amplifier to very high speed flash ADCs, the distortions introduced by the converter will dominate over the low LMH6702 distortions. The capacitor C_{SS} , shown across the supplies in [Figure 21](#) and [Figure 22](#), is critical to achieving the lowest 2nd harmonic distortion. For absolute minimum distortion levels, it is also advisable to keep the supply decoupling currents (ground connections to C_{POS} , and C_{NEG} in [Figure 21](#) and [Figure 22](#)) separate from the ground connections to sensitive input circuitry (such as R_G , R_T , and R_{IN} ground connections). Splitting the ground plane in this fashion and separately routing the high frequency current spikes on the decoupling caps back to the power supply (similar to "Star Connection" layout technique) ensures minimum coupling back to the input circuitry and results in best harmonic distortion response (especially 2nd order distortion).

If this lay out technique has not been observed on a particular application board, designer may actually find that supply decoupling caps could adversely affect HD2 performance by increasing the coupling phenomenon already mentioned. Figure 23 below shows actual HD2 data on a board where the ground plane is "shared" between the supply decoupling capacitors and the rest of the circuit. Once these capacitors are removed, the HD2 distortion levels reduce significantly, especially between 10MHz-20MHz, as shown in Figure 23 below:

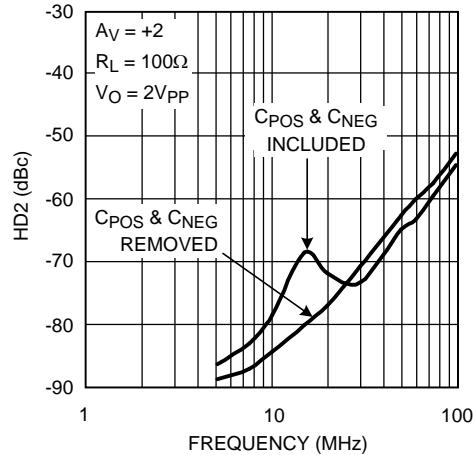

Figure 23. Decoupling Current Adverse Effect on a Board with Shared Ground Plane

At these extremely low distortion levels, the high frequency behavior of decoupling capacitors themselves could be significant. In general, lower value decoupling caps tend to have higher resonance frequencies making them more effective for higher frequency regions. A particular application board which has been laid out correctly with ground returns "split" to minimize coupling, would benefit the most by having low value and higher value capacitors paralleled to take advantage of the effective bandwidth of each and extend low distortion frequency range.

CAPACITIVE LOAD DRIVE

Figure 24 shows a typical application using the LMH6702 to drive an ADC.

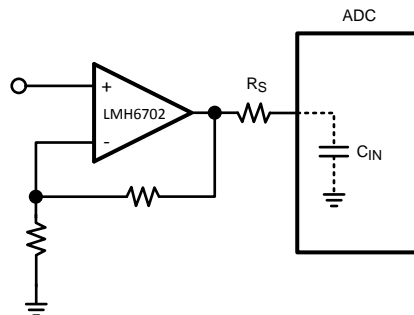

Figure 24. Input Amplifier to ADC

The series resistor, R_S , between the amplifier output and the ADC input is critical to achieving best system performance. This load capacitance, if applied directly to the output pin, can quickly lead to unacceptable levels of ringing in the pulse response. The plot of " R_S and Settling Time vs. C_L " in the Typical Performance Characteristics section is an excellent starting point for selecting R_S . The value derived in that plot minimizes the step settling time into a fixed discrete capacitive load with the output driving a very light resistive load (1k Ω). Sensitivity to capacitive loading is greatly reduced once the output is loaded more heavily. Therefore, for cases where the output is heavily loaded, R_S value may be reduced. The exact value may best be determined experimentally for these cases.

In applications where the LMH6702 is replacing the CLC409, care must be taken when the device is lightly loaded and some capacitance is present at the output. Due to the much higher frequency response of the LMH6702 compared to the CLC409, there could be increased susceptibility to low value output capacitance (parasitic or inherent to the board layout or otherwise being part of the output load). As already mentioned, this susceptibility is most noticeable when the LMH6702's resistive load is light. Parasitic capacitance can be minimized by careful lay out. Addition of an output snubber R-C network will also help by increasing the high frequency resistive loading.

Referring back to [Figure 24](#), it must be noted that several additional constraints should be considered in driving the capacitive input of an ADC. There is an option to increase R_S , band-limiting at the ADC input for either noise or Nyquist band-limiting purposes. Increasing R_S too much, however, can induce an unacceptably large input glitch due to switching transients coupling through from the "convert" signal. Also, C_{IN} is oftentimes a voltage dependent capacitance. This input impedance non-linearity will induce distortion terms that will increase as R_S is increased. Only slight adjustments up or down from the recommended R_S value should therefore be attempted in optimizing system performance.

DC ACCURACY AND NOISE

Example below shows the output offset computation equation for the non-inverting configuration using the typical bias current and offset specifications for $A_V = +2$:

$$\text{Output Offset} : V_O = (\pm I_{BN} \cdot R_{IN} \pm V_{IO}) (1 + R_F/R_G) \pm I_{BI} \cdot R_F$$

Where R_{IN} is the equivalent input impedance on the non-inverting input.

Example computation for $A_V = +2$, $R_F = 237\Omega$, $R_{IN} = 25\Omega$:

$$V_O = (\pm 6\mu A \cdot 25\Omega \pm 1mV) (1 + 237/237) \pm 8\mu A \cdot 237 = \pm 4.20mV$$

A good design, however, should include a worst case calculation using Min/Max numbers in the data sheet tables, in order to ensure "worst case" operation.

Further improvement in the output offset voltage and drift is possible using the composite amplifiers described in Application Note OA-7 [SNOA365](#). The two input bias currents are physically unrelated in both magnitude and polarity for the current feedback topology. It is not possible, therefore, to cancel their effects by matching the source impedance for the two inputs (as is commonly done for matched input bias current devices).

The total output noise is computed in a similar fashion to the output offset voltage. Using the input noise voltage and the two input noise currents, the output noise is developed through the same gain equations for each term but combined as the square root of the sum of squared contributing elements. See Application Note OA-12 [SNOA375](#) for a full discussion of noise calculations for current feedback amplifiers.

PRINTED CIRCUIT LAYOUT

Generally, a good high frequency layout will keep power supply and ground traces away from the inverting input and output pins. Parasitic capacitances on these nodes to ground will cause frequency response peaking and possible circuit oscillations (see Application Note OA-15 [SNOA367](#) for more information). Texas Instruments suggests the following evaluation boards as a guide for high frequency layout and as an aid in device testing and characterization:

Device	Package	Evaluation Board Part Number
LMH6702QMLMF	SOT-23-5	CLC730216
LMH6702QMLMA	Plastic SOIC	CLC730227

Table 1. Revision History

Date Released	Revision	Section	Originator	Changes
07/12/05	A	New Corporate format Release	R. Malone	1 MDS data sheet converted in corporate data sheet format. Added reference to QMLV products and Drift Table. MDS MNL6702-X, Rev. 1A0 will be archived.
09/28/05	B	Features, Ordering Information Table and Notes	R. Malone	Added radiation reference to Features, Rad NSID & SMD to Ordering Table and Note 5 to AC & DC Electrical tables. Note to note section.
11/07/05	C	Update AC electrical's and Notes	R. Malone	Added note to AC electrical's and note section. LMH6702QML Revision B data sheet will be archived.
07/26/2011	D	Update Features, Ordering Information and Footnotes	Larry M.	Added 'High Dose Rate' 300 krad(Si) and ELDRS Free 300 krad(Si). Deleted NS Part numbers LMH6702J-QML and LMH6702WG-QML. Added NS Part number LMH6702WGFLQMLV. Modified note . LMH6702QML Revision C data sheet will be archived.
10/05/2011	E	Update Ordering Information, and Footnotes	Kirby K..	Added NS Part number LMH6702JFLQMLV 300 krad(Si) .Modified note and note . Revision D data sheet will be archived.
03/18/2013	E	All	-	Changed layout of National Data Sheet to TI format

PACKAGING INFORMATION

Orderable Device	Status (1)	Package Type	Package Drawing	Pins	Package Qty	Eco Plan (2)	Lead/Ball Finish	MSL Peak Temp (3)	Op Temp (°C)	Top-Side Markings (4)	Samples
5962-0254601VPA	ACTIVE	CDIP	NAB	8	40	TBD	Call TI	Call TI	-55 to 125	LMH6702J-QV 5962-02546 01VPA Q ACO 01VPA Q >T	Samples
5962-0254601VZA	ACTIVE	CFP	NAC	10	54	TBD	Call TI	Call TI	-55 to 125	LMH6702 WGQMLV Q 5962-04203 01VZA ACO 01VZA >T	Samples
5962F0254601VPA	ACTIVE	CDIP	NAB	8	40	TBD	Call TI	Call TI	-55 to 125	LMH6702JFQV 5962F02546 01VPA Q ACO 01VPA Q >T	Samples
5962F0254601VZA	ACTIVE	CFP	NAC	10	54	TBD	Call TI	Call TI	-55 to 125	LMH6702 WGFQMLV Q 5962F02546 01VZA ACO 01VZA >T	Samples
LMH6702J-QMLV	ACTIVE	CDIP	NAB	8	40	TBD	Call TI	Call TI	-55 to 125	LMH6702J-QV 5962-02546 01VPA Q ACO 01VPA Q >T	Samples
LMH6702JFQMLV	ACTIVE	CDIP	NAB	8	40	TBD	Call TI	Call TI	-55 to 125	LMH6702JFQV 5962F02546 01VPA Q ACO 01VPA Q >T	Samples
LMH6702WG-QMLV	ACTIVE	CFP	NAC	10	54	TBD	Call TI	Call TI	-55 to 125	LMH6702 WGQMLV Q 5962-04203 01VZA ACO 01VZA >T	Samples
LMH6702WGFQMLV	ACTIVE	CFP	NAC	10	54	TBD	Call TI	Call TI	-55 to 125	LMH6702 WGFQMLV Q 5962F02546 01VZA ACO 01VZA >T	Samples

(1) The marketing status values are defined as follows:

ACTIVE: Product device recommended for new designs.

LIFEBUY: TI has announced that the device will be discontinued, and a lifetime-buy period is in effect.

NRND: Not recommended for new designs. Device is in production to support existing customers, but TI does not recommend using this part in a new design.

PREVIEW: Device has been announced but is not in production. Samples may or may not be available.

OBSOLETE: TI has discontinued the production of the device.

(2) Eco Plan - The planned eco-friendly classification: Pb-Free (RoHS), Pb-Free (RoHS Exempt), or Green (RoHS & no Sb/Br) - please check <http://www.ti.com/productcontent> for the latest availability information and additional product content details.

TBD: The Pb-Free/Green conversion plan has not been defined.

Pb-Free (RoHS): TI's terms "Lead-Free" or "Pb-Free" mean semiconductor products that are compatible with the current RoHS requirements for all 6 substances, including the requirement that lead not exceed 0.1% by weight in homogeneous materials. Where designed to be soldered at high temperatures, TI Pb-Free products are suitable for use in specified lead-free processes.

Pb-Free (RoHS Exempt): This component has a RoHS exemption for either 1) lead-based flip-chip solder bumps used between the die and package, or 2) lead-based die adhesive used between the die and leadframe. The component is otherwise considered Pb-Free (RoHS compatible) as defined above.

Green (RoHS & no Sb/Br): TI defines "Green" to mean Pb-Free (RoHS compatible), and free of Bromine (Br) and Antimony (Sb) based flame retardants (Br or Sb do not exceed 0.1% by weight in homogeneous material)

(3) MSL, Peak Temp. -- The Moisture Sensitivity Level rating according to the JEDEC industry standard classifications, and peak solder temperature.

(4) Multiple Top-Side Markings will be inside parentheses. Only one Top-Side Marking contained in parentheses and separated by a "~" will appear on a device. If a line is indented then it is a continuation of the previous line and the two combined represent the entire Top-Side Marking for that device.

Important Information and Disclaimer: The information provided on this page represents TI's knowledge and belief as of the date that it is provided. TI bases its knowledge and belief on information provided by third parties, and makes no representation or warranty as to the accuracy of such information. Efforts are underway to better integrate information from third parties. TI has taken and continues to take reasonable steps to provide representative and accurate information but may not have conducted destructive testing or chemical analysis on incoming materials and chemicals. TI and TI suppliers consider certain information to be proprietary, and thus CAS numbers and other limited information may not be available for release.

In no event shall TI's liability arising out of such information exceed the total purchase price of the TI part(s) at issue in this document sold by TI to Customer on an annual basis.

OTHER QUALIFIED VERSIONS OF LMH6702QML, LMH6702QML-SP :

● Catalog: [LMH6702QML](#)

● Space: [LMH6702QML-SP](#)

NOTE: Qualified Version Definitions:

● Catalog - TI's standard catalog product

● Space - Radiation tolerant, ceramic packaging and qualified for use in Space-based application

NAB0008A

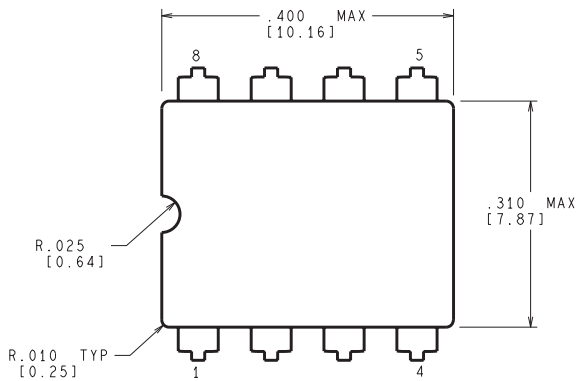

CONTROLLING DIMENSION IS INCH
VALUES IN [] ARE MILLIMETERS

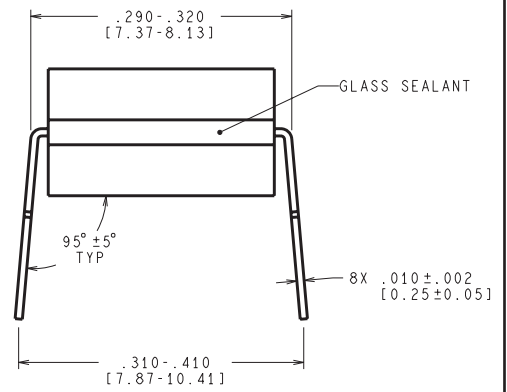
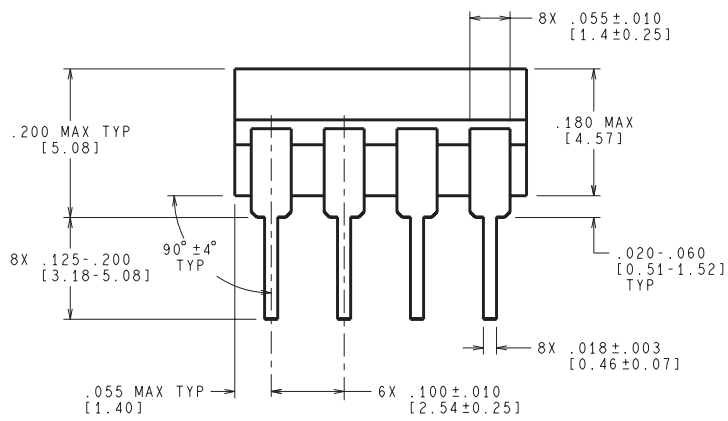

J08A (Rev M)

NAC0010A

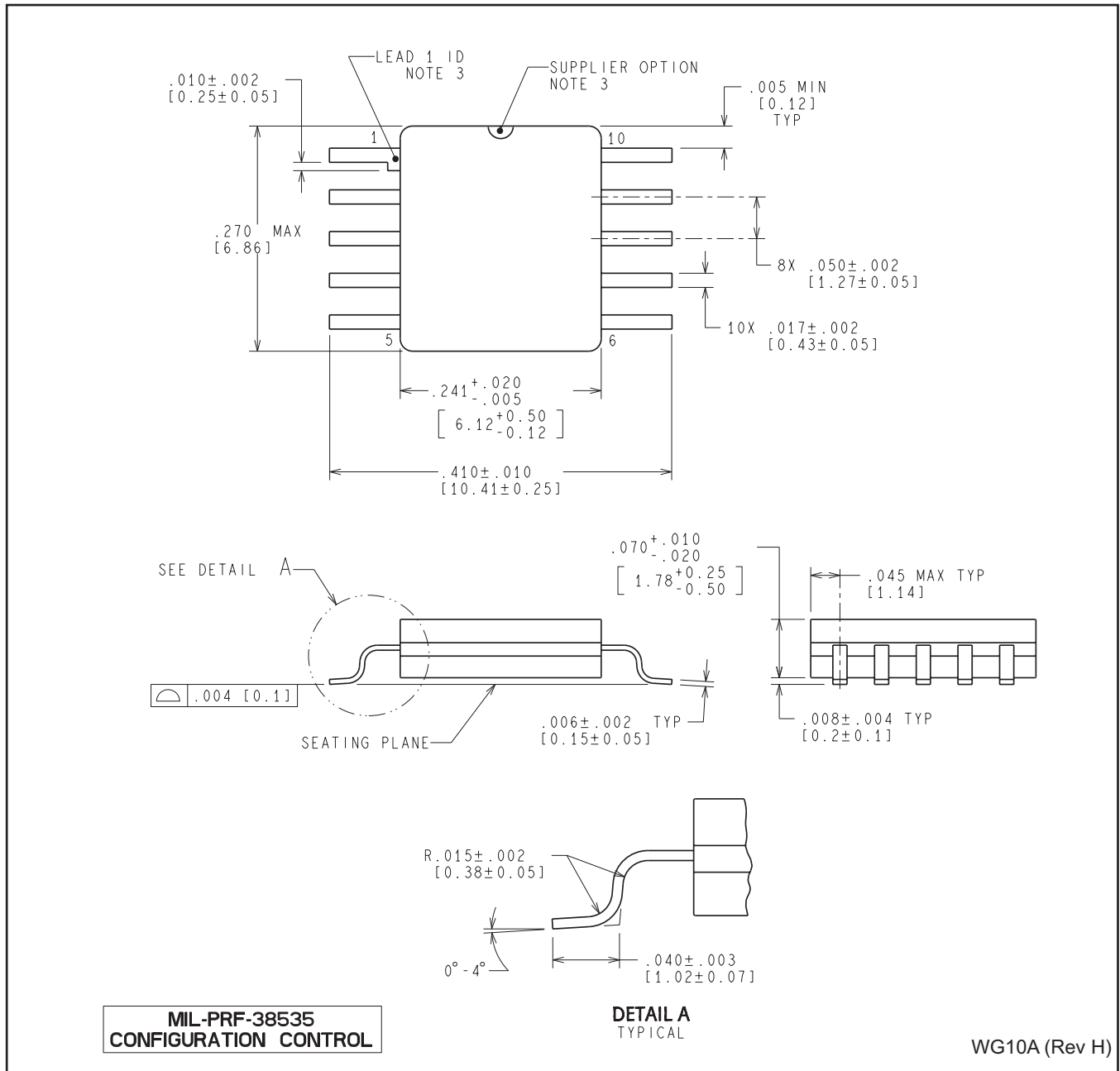

IMPORTANT NOTICE

Texas Instruments Incorporated and its subsidiaries (TI) reserve the right to make corrections, enhancements, improvements and other changes to its semiconductor products and services per JESD46, latest issue, and to discontinue any product or service per JESD48, latest issue. Buyers should obtain the latest relevant information before placing orders and should verify that such information is current and complete. All semiconductor products (also referred to herein as "components") are sold subject to TI's terms and conditions of sale supplied at the time of order acknowledgment.

TI warrants performance of its components to the specifications applicable at the time of sale, in accordance with the warranty in TI's terms and conditions of sale of semiconductor products. Testing and other quality control techniques are used to the extent TI deems necessary to support this warranty. Except where mandated by applicable law, testing of all parameters of each component is not necessarily performed.

TI assumes no liability for applications assistance or the design of Buyers' products. Buyers are responsible for their products and applications using TI components. To minimize the risks associated with Buyers' products and applications, Buyers should provide adequate design and operating safeguards.

TI does not warrant or represent that any license, either express or implied, is granted under any patent right, copyright, mask work right, or other intellectual property right relating to any combination, machine, or process in which TI components or services are used. Information published by TI regarding third-party products or services does not constitute a license to use such products or services or a warranty or endorsement thereof. Use of such information may require a license from a third party under the patents or other intellectual property of the third party, or a license from TI under the patents or other intellectual property of TI.

Reproduction of significant portions of TI information in TI data books or data sheets is permissible only if reproduction is without alteration and is accompanied by all associated warranties, conditions, limitations, and notices. TI is not responsible or liable for such altered documentation. Information of third parties may be subject to additional restrictions.

Resale of TI components or services with statements different from or beyond the parameters stated by TI for that component or service voids all express and any implied warranties for the associated TI component or service and is an unfair and deceptive business practice. TI is not responsible or liable for any such statements.

Buyer acknowledges and agrees that it is solely responsible for compliance with all legal, regulatory and safety-related requirements concerning its products, and any use of TI components in its applications, notwithstanding any applications-related information or support that may be provided by TI. Buyer represents and agrees that it has all the necessary expertise to create and implement safeguards which anticipate dangerous consequences of failures, monitor failures and their consequences, lessen the likelihood of failures that might cause harm and take appropriate remedial actions. Buyer will fully indemnify TI and its representatives against any damages arising out of the use of any TI components in safety-critical applications.

In some cases, TI components may be promoted specifically to facilitate safety-related applications. With such components, TI's goal is to help enable customers to design and create their own end-product solutions that meet applicable functional safety standards and requirements. Nonetheless, such components are subject to these terms.

No TI components are authorized for use in FDA Class III (or similar life-critical medical equipment) unless authorized officers of the parties have executed a special agreement specifically governing such use.

Only those TI components which TI has specifically designated as military grade or "enhanced plastic" are designed and intended for use in military/aerospace applications or environments. Buyer acknowledges and agrees that any military or aerospace use of TI components which have **not** been so designated is solely at the Buyer's risk, and that Buyer is solely responsible for compliance with all legal and regulatory requirements in connection with such use.

TI has specifically designated certain components as meeting ISO/TS16949 requirements, mainly for automotive use. In any case of use of non-designated products, TI will not be responsible for any failure to meet ISO/TS16949.

Products

Audio	www.ti.com/audio
Amplifiers	amplifier.ti.com
Data Converters	dataconverter.ti.com
DLP® Products	www.dlp.com
DSP	dsp.ti.com
Clocks and Timers	www.ti.com/clocks
Interface	interface.ti.com
Logic	logic.ti.com
Power Mgmt	power.ti.com
Microcontrollers	microcontroller.ti.com
RFID	www.ti-rfid.com
OMAP Applications Processors	www.ti.com/omap
Wireless Connectivity	www.ti.com/wirelessconnectivity

Applications

Automotive and Transportation	www.ti.com/automotive
Communications and Telecom	www.ti.com/communications
Computers and Peripherals	www.ti.com/computers
Consumer Electronics	www.ti.com/consumer-apps
Energy and Lighting	www.ti.com/energy
Industrial	www.ti.com/industrial
Medical	www.ti.com/medical
Security	www.ti.com/security
Space, Avionics and Defense	www.ti.com/space-avionics-defense
Video and Imaging	www.ti.com/video

TI E2E Community

e2e.ti.com