

100V Current Mode PWM Controller

 Check for Samples: [SM74202](#)

FEATURES

- Renewable Energy Grade
- Internal Start-up Bias Regulator
- Error Amplifier
- Precision Voltage Reference
- Programmable Softstart
- 1A Peak Gate Driver
- Maximum Duty Cycle Limiting (50%)
- Programmable Line Under Voltage Lockout (UVLO) with Adjustable Hysteresis
- Cycle-by-Cycle Over-Current Protection
- Programmable Oscillator Frequency with Synchronization Capability
- Current Sense Leading Edge Blanking
- Thermal Shutdown Protection

DESCRIPTION

The SM74202 high voltage pulse-width-modulation (PWM) controller contains all of the features needed to implement single ended primary power converter topologies. Output voltage regulation is based on current-mode control, which eases the design of loop compensation while providing inherent line feed-forward. The SM74202 includes a high-voltage start-up regulator that operates over a wide input range up to 100V. The PWM controller is designed for high speed capability including an oscillator frequency range to 1MHz and total propagation delays less than 100ns. Additional features include an error amplifier, precision reference, line under-voltage lockout, cycle-by-cycle current limit, slope compensation, softstart, oscillator synchronization capability and thermal shutdown. The controller is available in the MSOP-10 package.

APPLICATIONS

- Photovoltaic
- Telecommunication Power Converters
- Industrial Power Converters
- +42V Automotive Systems

Typical Application Circuit

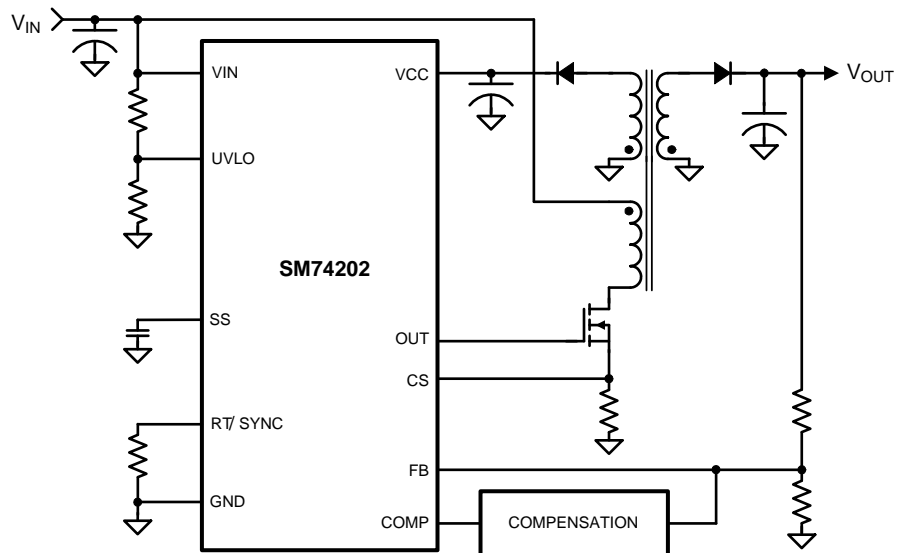

Figure 1. Non-Isolated Flyback Converter



Please be aware that an important notice concerning availability, standard warranty, and use in critical applications of Texas Instruments semiconductor products and disclaimers thereto appears at the end of this data sheet.

All trademarks are the property of their respective owners.

Connection Diagram

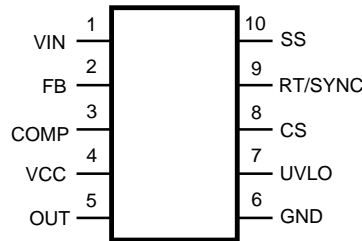

**Figure 2. 10-Lead VSSOP, WSON
Package Number DGS0010A
Top View**

PIN DESCRIPTIONS

Pin	Name	Description	Application Information
1	VIN	Source Input Voltage	Input to the start-up regulator. Input range is 13V to 100V.
2	FB	Feedback Signal	Inverting input of the internal error amplifier. The non-inverting input is internally connected to a 1.25V reference.
3	COMP	The output of the error amplifier and input to the Pulse Width Modulator	COMP pull-up is provided by an internal 5K resistor which may be used to bias an opto-coupler transistor.
4	VCC	Output of the internal high voltage series pass regulator. Regulated output voltage is 7.7V	If an auxiliary winding raises the voltage on this pin above the regulation set point, the internal series pass regulator will shut down, reducing the internal power dissipation.
5	OUT	Output of the PWM controller	Gate driver output with a 1A peak current capability.
6	GND	Ground return	
7	UVLO	Line Under-Voltage Shutdown	An external resistor divider from the power converter source voltage sets the shutdown levels. The threshold at this pin is 1.25V. Hysteresis is set by a switched internal 20 μ A current source.
8	CS	Current Sense input	Current sense input for current mode control and over-current protection. Current limiting is accomplished using a dedicated current sense comparator. If the CS pin voltage exceeds 0.5V the OUT pin switches low for cycle-by-cycle current limiting. CS is held low for 50ns after OUT switches high to blank leading edge current spikes.
9	RT / SYNC	Oscillator timing resistor pin and synchronization input	An external resistor connected from RT to GND sets the oscillator frequency. This pin also accepts synchronization pulses from an external clock.
10	SS	Softstart Input	An external capacitor and an internal 10 μ A current source set the soft-start ramp rate.



These devices have limited built-in ESD protection. The leads should be shorted together or the device placed in conductive foam during storage or handling to prevent electrostatic damage to the MOS gates.

Absolute Maximum Ratings ⁽¹⁾⁽²⁾

VIN to GND	-0.3V to 100V
VCC to GND	-0.3V to 16V
All other pins to GND	-0.3V to 7V
Power Dissipation	Internally Limited
ESD Rating ⁽³⁾ Human Body Model	2kV
Storage Temperature	-65°C to +150°C
Junction Temperature	150°C

- (1) Absolute Maximum Ratings are limits beyond which damage to the device may occur. Operating Ratings are conditions under which operation of the device is intended to be functional. For ensured specifications and test conditions, see the Electrical Characteristics.
- (2) If Military/Aerospace specified devices are required, please contact the Texas Instruments Sales Office/ Distributors for availability and specifications.
- (3) The human body model is a 100 pF capacitor discharged through a 1.5kΩ resistor.

Operating Ratings

VIN Voltage	13V to 90V
External Voltage applied to VCC	8V to 15V
Operating Junction Temperature	-40°C to +125°C

Electrical Characteristics

Specifications in standard type face are for $T_j = +25^\circ\text{C}$ and those in **boldface type** apply over the full operating junction temperature range. Unless otherwise specified: $V_{IN} = 48\text{V}$, $V_{CC} = 10\text{V}$, and $R_T = 31.6\text{k}\Omega$. ⁽¹⁾

Symbol	Parameter	Conditions	Min	Typ	Max	Units
Startup Regulator						
V_{CCReg}	V_{CC} Regulation	$V_{CC} = \text{Open}$	7.4	7.7	8.0	V
	V_{CC} Current Limit	⁽²⁾	15	22		mA
$I-V_{IN}$	Startup Regulator Leakage	$V_{IN} = 100\text{V}$		150	500	μA
I_{IN}	Shutdown Current	$V_{UVLO} = 0\text{V}$, $V_{CC} = \text{open}$		250	350	μA
VCC Supply						
	V_{CC} UVLO (Rising)		VccReg - 300mV	$V_{CCReg} - 100\text{mV}$		V
	V_{CC} UVLO (Falling)		5.3	6.0	6.7	V
I_{CC}	Supply Current	Load = 0		2	3	mA
Error Amplifier						
GBW	Gain Bandwidth			4		MHz
	DC Gain			75		dB
	Reference Voltage	FB = COMP	1.225	1.25	1.275	V
	COMP Sink Capability	FB = 1.5V COMP = 1V	5	17		mA
UVLO Pin						
	Shutdown Threshold			1.25		V
	Undervoltage Shutdown Hysteresis Current Source		16	20	24	μA
Current Limit						
	ILIM Delay to Output	CS step from 0 to 0.6V Time to onset of OUT Transition (90%)		30		ns
	Cycle by Cycle CS Threshold Voltage			0.5		V
	Leading Edge Blanking Time			50		ns

- (1) Limits are 100% production tested at 25°C. Limits over the operating temperature range are ensured through correlation using Statistical Quality Control (SQC) methods. The limits are used to calculate TI's Average Outgoing Quality Level (AOQL).
- (2) Device thermal limitations may limit usable range.

Electrical Characteristics (continued)

Specifications in standard type face are for $T_J = +25^\circ\text{C}$ and those in **boldface type** apply over the full operating junction temperature range. Unless otherwise specified: $V_{IN} = 48\text{V}$, $V_{CC} = 10\text{V}$, and $R_T = 31.6\text{k}\Omega$. ⁽¹⁾

Symbol	Parameter	Conditions	Min	Typ	Max	Units
	CS Sink Impedance (clocked)			35		Ω
Soft Start						
	Softstart Current Source		7	10	13	μA
	Softstart to COMP Offset		0.35	0.55	0.75	V
Oscillator						
	Frequency1 (RT = 31.6k)	⁽³⁾	175	200	225	kHz
	Frequency2 (RT = 9.76k)	⁽³⁾	560	630	700	kHz
	Sync threshold		2.4	3.2	3.8	V
PWM Comparator						
	Delay to Output	COMP set to 2V, CS stepped 0 to 0.4V, Time to onset of OUT transition low		25		ns
	Min Duty Cycle	COMP=0V			0	%
	Max Duty Cycle			50		%
	COMP to PWM Comparator Gain			0.33		
	COMP Open Circuit Voltage		4.3	5.2	6.1	V
	COMP Short Circuit Current	COMP=0V	0.6	1.1	1.5	mA
Output Section						
	Output High Saturation	$I_{out} = 50\text{mA}$, $V_{CC} - V_{OUT}$		0.25	0.75	V
	Output Low Saturation	$I_{OUT} = 100\text{mA}$, V_{OUT}		0.25	0.75	V
	Rise Time	Clload = 1nF		18		ns
	Fall Time	Clload = 1nF		15		ns
Thermal Shutdown						
Tsd	Thermal Shutdown Temp.			165		$^\circ\text{C}$
	Thermal Shutdown Hysteresis			25		$^\circ\text{C}$

(3) Specification applies to the oscillator frequency. The operational frequency of the SM74202 is divided by two.

Typical Performance Characteristics

Unless otherwise specified: $T_J = 25^\circ\text{C}$.

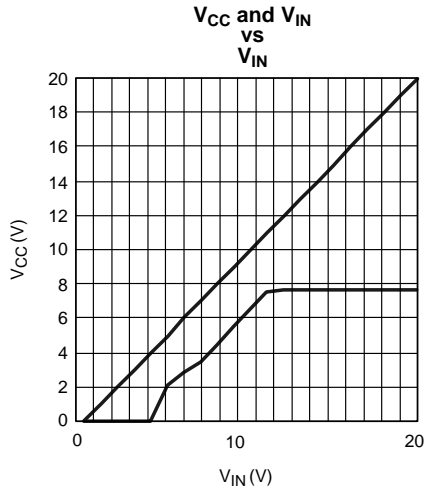

Figure 3.

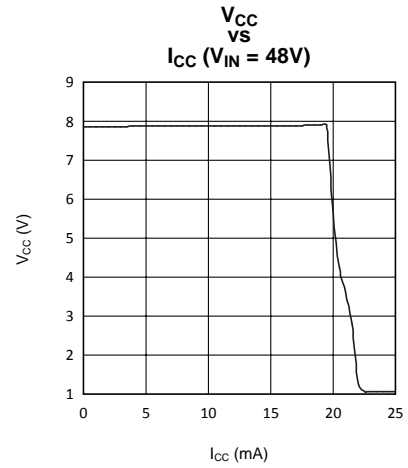

Figure 4.

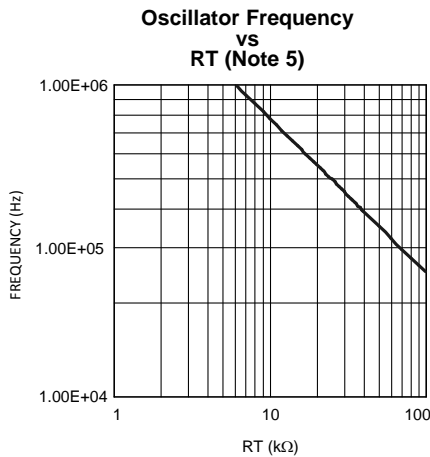

Figure 5.

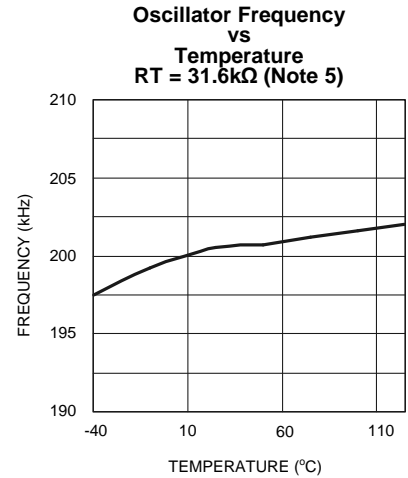

Figure 6.

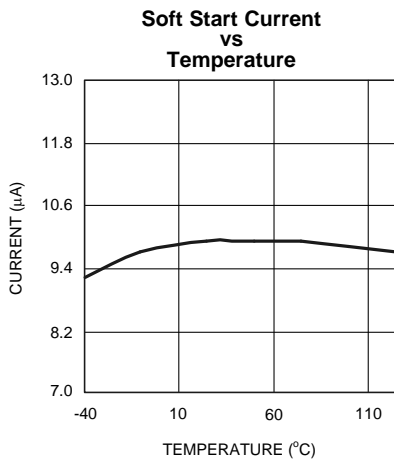

Figure 7.

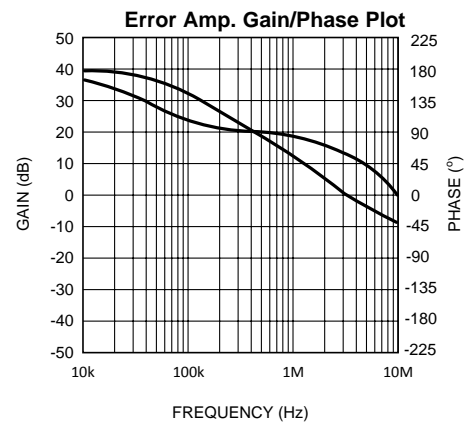
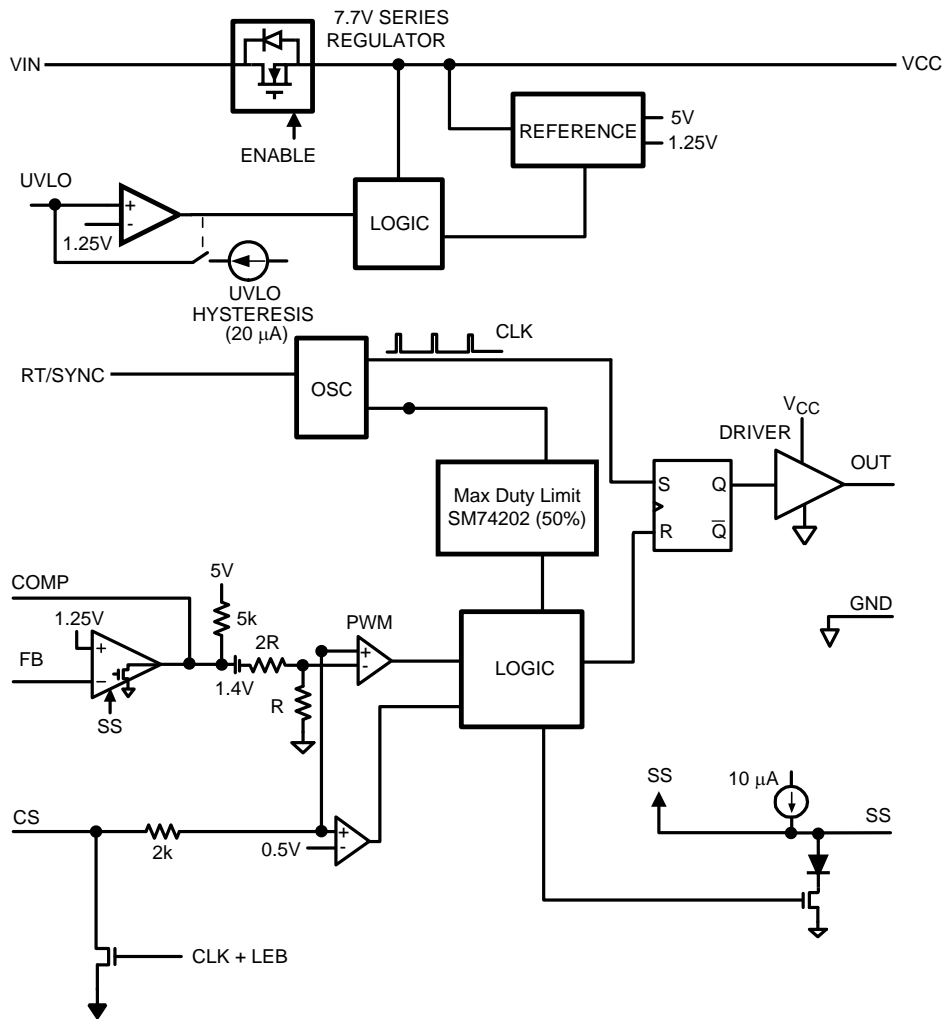

Figure 8.

Block Diagram



DETAILED OPERATING DESCRIPTION

The SM74202 High Voltage PWM controller contains all of the features needed to implement single ended primary power converter topologies. The SM74202 includes a high-voltage startup regulator that operates over a wide input range to 100V. The PWM controller is designed for high speed capability including an oscillator frequency range to 1MHz and total propagation delays less than 100ns. Additional features include an error amplifier, precision reference, line under-voltage lockout, cycle-by-cycle current limit, softstart, oscillator sync capability and thermal shutdown. The functional block diagram of the SM74202 is shown in the [Block Diagram](#). The SM74202 is designed for current-mode control power converters, which require a single drive output, such as Flyback and Forward topologies. The SM74202 provides all of the advantages of current-mode control including line feed-forward, cycle-by-cycle current limiting and simplified loop compensation .

High Voltage Start-Up Regulator

The SM74202 contains an internal high voltage startup regulator, that allows the input pin (V_{in}) to be connected directly to line voltages as high as 100V. The regulator output is internally current limited to 15mA. When power is applied, the regulator is enabled and sources current into an external capacitor connected to the V_{CC} pin. The recommended capacitance range for the V_{CC} regulator is 0.1 μ F to 100 μ F. When the voltage on the V_{CC} pin reaches the regulation level of 7.7V, the controller output is enabled. The controller will remain enabled until V_{CC} falls below 6V.

In typical applications, a transformer auxiliary winding is connected through a diode to the V_{CC} pin. This winding should raise the V_{CC} voltage above 8V to shut off the internal startup regulator. Powering V_{CC} from an auxiliary winding improves conversion efficiency while reducing the power dissipated in the controller. The external V_{CC} capacitor must be selected such that the capacitor maintains the V_{CC} voltage greater than the V_{CC} UVLO falling threshold (6V) during the initial start-up. During a fault condition when the converter auxiliary winding is inactive, external current draw on the V_{CC} line should be limited such that the power dissipated in the start-up regulator does not exceed the maximum power dissipation capability of the controller.

An external start-up or other bias rail can be used instead of the internal start-up regulator by connecting the V_{CC} and the V_{in} pins together and feeding the external bias voltage (8-15V) to the two pins.

Line Under Voltage Detector

The SM74202 contains a line Under Voltage Lock Out (UVLO) circuit. An external set-point voltage divider from V_{in} to GND sets the operational range of the converter. The resistor divider must be designed such that the voltage at the UVLO pin is greater than 1.25V when V_{in} is in the desired operating range. If the under voltage threshold is not met, all functions of the controller are disabled and the controller remains in a low power standby state.

UVLO hysteresis is accomplished with an internal 20 μ A current source that is switched on or off into the impedance of the set-point divider. When the UVLO threshold is exceeded, the current source is activated to instantly raise the voltage at the UVLO pin. When the UVLO pin voltage falls below the 1.25V threshold the current source is turned off, causing the voltage at the UVLO pin to fall. The UVLO pin can also be used to implement a remote enable / disable function. If an external transistor pulls the UVLO pin below the 1.25V threshold, the converter is disabled.

Error Amplifier

An internal high gain error amplifier is provided within the SM74202. The amplifier's non-inverting input is internally set to a fixed reference voltage of 1.25V. The inverting input is connected to the FB pin. In non-isolated applications, the power converter output is connected to the FB pin via voltage scaling resistors. Loop compensation components are connected between the COMP and FB pins. For most isolated applications the error amplifier function is implemented on the secondary side of the converter and the internal error amplifier is not used. The internal error amplifier is configured as an open drain output and can be disabled by connecting the FB pin to ground. An internal 5K pull-up resistor between a 5V reference and COMP can be used as the pull-up for an optocoupler in isolated applications.

Current Limit/Current Sense

The SM74202 provides a cycle-by-cycle over current protection function. Current limit is accomplished by an internal current sense comparator. If the voltage at the current sense comparator input exceeds 0.5V, the output is immediately terminated. A small RC filter, located near the controller, is recommended to filter noise from the current sense signal. The CS input has an internal MOSFET which discharges the CS pin capacitance at the conclusion of every cycle. The discharge device remains on an additional 50ns after the beginning of the new cycle to attenuate the leading edge spike on the current sense signal.

The SM74202 current sense and PWM comparators are very fast, and may respond to short duration noise pulses. Layout considerations are critical for the current sense filter and sense resistor. The capacitor associated with the CS filter must be located very close to the SM74202 and connected directly to the pins of the controller (CS and GND). If a current sense transformer is used, both leads of the transformer secondary should be routed to the sense resistor and the current sense filter network. A sense resistor located in the source of the primary power MOSFET may be used for current sensing, but a low inductance resistor is required. When designing with a current sense resistor all of the noise sensitive low power ground connections should be connected together local to the controller and a single connection should be made to the high current power ground (sense resistor ground point).

Oscillator and Sync Capability

A single external resistor connected between the RT and GND pins sets the SM74202 oscillator frequency. Internal to the device is an oscillator divide by two circuit. This divide by two circuit creates an exact 50% duty cycle limit function. Because of this, the internal oscillator actually operates at twice the frequency of the output (OUT). To set a desired output operational frequency (F), the RT resistor can be calculated from:

$$RT = \frac{1}{F \times 158 \times 10^{-12}} \quad (1)$$

The SM74202 can also be synchronized to an external clock. The external clock must have a higher frequency than the free running oscillator frequency set by the RT resistor. The clock signal should be capacitively coupled into the RT pin through a 100pF capacitor. A peak voltage level greater than 3.7 Volts at the RT pin is required for detection of the sync pulse. The sync pulse width should be set between 15 to 150ns by the external components. The RT resistor is always required, whether the oscillator is free running or externally synchronized. The voltage at the RT pin is internally regulated at 2 Volts. The RT resistor should be located very close to the device and connected directly to the pins of the controller (RT and GND).

PWM Comparator

The PWM comparator compares the current ramp signal with the loop error voltage derived from the error amplifier output. The error amplifier output voltage at the COMP pin is offset by 1.4V and then further attenuated by a 3:1 resistor divider. The PWM comparator polarity is such that 0 Volts on the COMP pin will result in a zero duty cycle at the controller output.

Soft Start

The softstart feature allows the power converter to gradually reach the initial steady state operating point, thereby reducing start-up stresses and current surges. At power on, after the V_{CC} and the line undervoltage lockout thresholds are satisfied, an internal 10 μ A current source charges an external capacitor connected to the SS pin. The capacitor voltage will ramp up slowly and will limit the COMP pin voltage and the duty cycle of the output pulses.

Gate Driver and Maximum Duty Cycle Limit

The SM74202 provides an internal gate driver (OUT), which can source and sink a peak current of 1 Amp. The maximum output duty cycle is precisely equal to 50%. The maximum duty cycle function is accomplished with an internal toggle flip-flop which ensures an accurate duty cycle limit. The internal oscillator frequency is therefore twice the operating frequency of the PWM controller (OUT pin).

Thermal Protection

Internal thermal shutdown circuitry is provided to protect the integrated circuit in the event the maximum junction temperature is exceeded. This feature prevents catastrophic failures from accidental device overheating. When activated, typically at 165 degrees Celsius, the controller is forced into a low power standby state, disabling the output driver and the bias regulator. After the temperature is reduced (typical hysteresis = 25°C) the V_{CC} regulator is enabled and a softstart sequence initiated.

Typical Application Circuit: 36V - 75 V_{IN} and 3.3V, 4.5A OUT

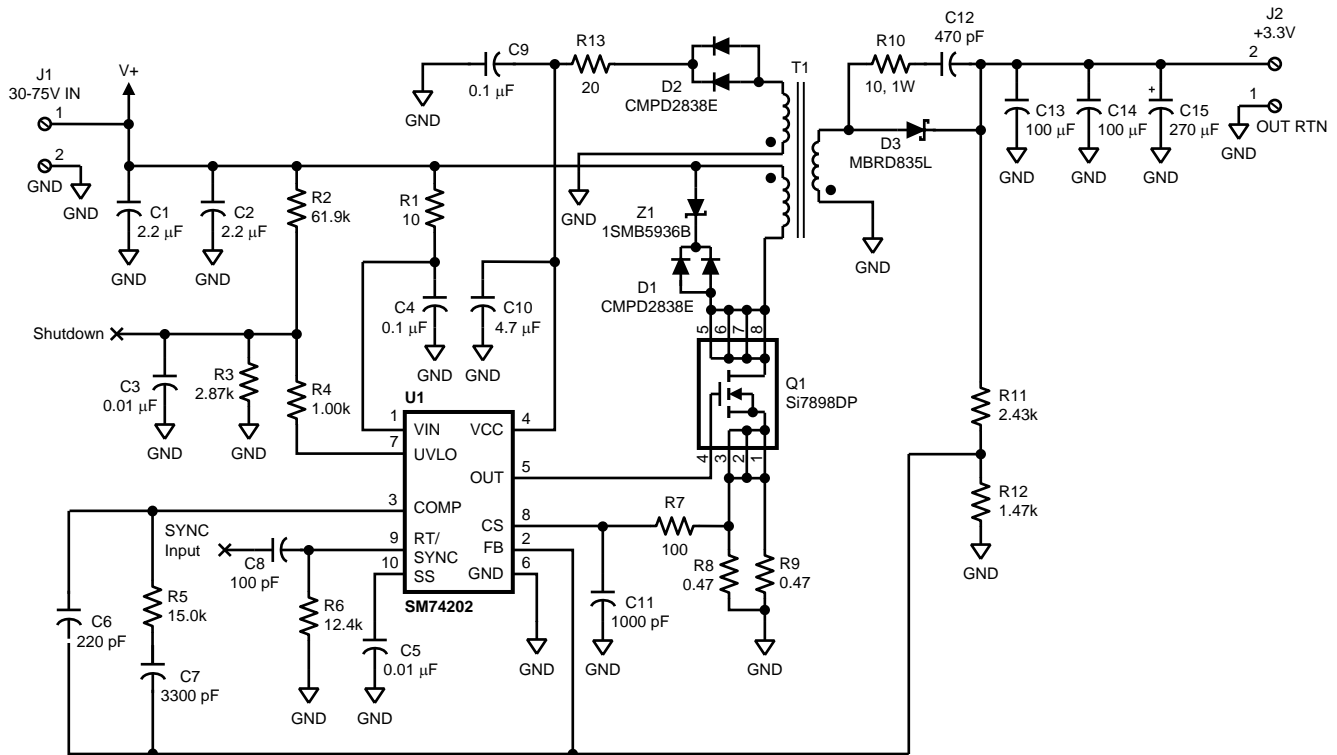

Bill Of Materials

ITEM	PART NUMBER	DESCRIPTION	VALUE
C 1	C4532X7R2A225M	CAPACITOR, CER, TDK	2.2 μ F, 100V
C 2	C4532X7R2A225M	CAPACITOR, CER, TDK	2.2 μ F, 100V
C 3	C2012X7R1H103K	CAPACITOR, CER, TDK	0.01 μ F, 50V
C 4	C3216X7R2A104K	CAPACITOR, CER, TDK	0.1 μ F, 100V
C 5	C2012X7R1H103K	CAPACITOR, CER, TDK	0.01 μ F, 50V
C 6	C2012C0G1H221J	CAPACITOR, CER, KEMET	220pF, 50V
C 7	C2012C0G1H332J	CAPACITOR, CER, TDK	3300pF, 50V
C 8	C2012C0G1H101J	CAPACITOR, CER, TDK	100pF, 50V
C 9	C2012X7R1H104K	CAPACITOR, CER, TDK	0.1 μ F, 50V
C 10	C3216X7R1C475K	CAPACITOR, CER, TDK	4.7 μ F, 16V
C 11	C2012C0G1H102J	CAPACITOR, CER, TDK	1000pF, 50V
C 12	C2012C0G1H471J	CAPACITOR, CER, TDK	470p, 50V
C 13	C4532X7S0G107M	CAPACITOR, CER, TDK	100 μ F, 4V
C 14	C4532X7S0G107M	CAPACITOR, CER, TDK	100 μ F, 4V
C 15	A700X277M0004AT	CAPACITOR, ALUM ORGANIC, KEMET	270 μ F, 4V
D 1	CMPD2838E-NSA	DIODE, SIGNAL, CENTRAL	

ITEM		PART NUMBER	DESCRIPTION	VALUE
D	2	CMPD2838E-NSA	DIODE, SIGNAL, CENTRAL	
D	3	MBRD835L	DIODE, RECTIFIER, ON SEMICONDUCTOR	
J	1	MKDS 1/2-3.81	TERM BLK, MINI, 2 POS, PHOENIX CONTACT	
J	2	MKDS 1/2-3.81	TERM BLK, MINI, 2 POS, PHOENIX CONTACT	
Q	1	SI7898DP	FET, SILICONIX	150V, 85mΩ
R	1	CRCW120610R0F	RESISTOR	10
R	2	CRCW12066192F	RESISTOR	61.9kΩ
R	3	CRCW08052871F	RESISTOR	2.87kΩ
R	4	CRCW08051001F	RESISTOR	1.00kΩ
R	5	CRCW08051502F	RESISTOR	15.0kΩ
R	6	CRCW08051242F	RESISTOR	12.4kΩ
R	7	CRCW08051000F	RESISTOR	100
R	8	CRCW12060R47F	RESISTOR	0.47
R	9	CRCW12060R47F	RESISTOR	0.47
R	10	CRCW251210R0F	RESISTOR	10, 1W
R	11	CRCW08052431F	RESISTOR	2.43K
R	12	CRCW08051471F	RESISTOR	1.47K
R	13	CRCW080520R0F	RESISTOR	20
T	1	B0695-A COILCRAFT	TRANSFORMER, FLYBACK, EFD20 CORE	
T	1	PA0751 PULSE	TRANSFORMER, FLYBACK, EFD20 CORE	ALTERNATE
U	1	SM74202MM-2	CONTROLLER, SINGLE OUT, PWM, TI	
Z	1	1SMB5936B	DIODE, ZENER, SMB, 30V	

REVISION HISTORY

Changes from Original (April 2013) to Revision A	Page
<hr/> <ul style="list-style-type: none">• Changed layout of National Data Sheet to TI format <hr/>	<hr/> 9 <hr/>

IMPORTANT NOTICE

Texas Instruments Incorporated and its subsidiaries (TI) reserve the right to make corrections, enhancements, improvements and other changes to its semiconductor products and services per JESD46, latest issue, and to discontinue any product or service per JESD48, latest issue. Buyers should obtain the latest relevant information before placing orders and should verify that such information is current and complete. All semiconductor products (also referred to herein as "components") are sold subject to TI's terms and conditions of sale supplied at the time of order acknowledgment.

TI warrants performance of its components to the specifications applicable at the time of sale, in accordance with the warranty in TI's terms and conditions of sale of semiconductor products. Testing and other quality control techniques are used to the extent TI deems necessary to support this warranty. Except where mandated by applicable law, testing of all parameters of each component is not necessarily performed.

TI assumes no liability for applications assistance or the design of Buyers' products. Buyers are responsible for their products and applications using TI components. To minimize the risks associated with Buyers' products and applications, Buyers should provide adequate design and operating safeguards.

TI does not warrant or represent that any license, either express or implied, is granted under any patent right, copyright, mask work right, or other intellectual property right relating to any combination, machine, or process in which TI components or services are used. Information published by TI regarding third-party products or services does not constitute a license to use such products or services or a warranty or endorsement thereof. Use of such information may require a license from a third party under the patents or other intellectual property of the third party, or a license from TI under the patents or other intellectual property of TI.

Reproduction of significant portions of TI information in TI data books or data sheets is permissible only if reproduction is without alteration and is accompanied by all associated warranties, conditions, limitations, and notices. TI is not responsible or liable for such altered documentation. Information of third parties may be subject to additional restrictions.

Resale of TI components or services with statements different from or beyond the parameters stated by TI for that component or service voids all express and any implied warranties for the associated TI component or service and is an unfair and deceptive business practice. TI is not responsible or liable for any such statements.

Buyer acknowledges and agrees that it is solely responsible for compliance with all legal, regulatory and safety-related requirements concerning its products, and any use of TI components in its applications, notwithstanding any applications-related information or support that may be provided by TI. Buyer represents and agrees that it has all the necessary expertise to create and implement safeguards which anticipate dangerous consequences of failures, monitor failures and their consequences, lessen the likelihood of failures that might cause harm and take appropriate remedial actions. Buyer will fully indemnify TI and its representatives against any damages arising out of the use of any TI components in safety-critical applications.

In some cases, TI components may be promoted specifically to facilitate safety-related applications. With such components, TI's goal is to help enable customers to design and create their own end-product solutions that meet applicable functional safety standards and requirements. Nonetheless, such components are subject to these terms.

No TI components are authorized for use in FDA Class III (or similar life-critical medical equipment) unless authorized officers of the parties have executed a special agreement specifically governing such use.

Only those TI components which TI has specifically designated as military grade or "enhanced plastic" are designed and intended for use in military/aerospace applications or environments. Buyer acknowledges and agrees that any military or aerospace use of TI components which have **not** been so designated is solely at the Buyer's risk, and that Buyer is solely responsible for compliance with all legal and regulatory requirements in connection with such use.

TI has specifically designated certain components as meeting ISO/TS16949 requirements, mainly for automotive use. In any case of use of non-designated products, TI will not be responsible for any failure to meet ISO/TS16949.

Products

Audio	www.ti.com/audio
Amplifiers	amplifier.ti.com
Data Converters	dataconverter.ti.com
DLP® Products	www.dlp.com
DSP	dsp.ti.com
Clocks and Timers	www.ti.com/clocks
Interface	interface.ti.com
Logic	logic.ti.com
Power Mgmt	power.ti.com
Microcontrollers	microcontroller.ti.com
RFID	www.ti-rfid.com
OMAP Applications Processors	www.ti.com/omap
Wireless Connectivity	www.ti.com/wirelessconnectivity

Applications

Automotive and Transportation	www.ti.com/automotive
Communications and Telecom	www.ti.com/communications
Computers and Peripherals	www.ti.com/computers
Consumer Electronics	www.ti.com/consumer-apps
Energy and Lighting	www.ti.com/energy
Industrial	www.ti.com/industrial
Medical	www.ti.com/medical
Security	www.ti.com/security
Space, Avionics and Defense	www.ti.com/space-avionics-defense
Video and Imaging	www.ti.com/video

TI E2E Community

e2e.ti.com