

DS96F172M/DS96F174C/DS96F174M EIA-485/EIA-422 Quad Differential Drivers

Check for Samples: [DS96F172M](#), [DS96F174C](#), [DS96F174M](#)

FEATURES

- Meets EIA-485 and EIA-422 Standards
- Monotonic Differential Output Switching
- Tri-state Outputs
- Designed for Multipoint Bus Transmission
- Common Mode Output Voltage Range: $-7.0V$ to $+12V$
- Operates from Single $+5.0V$ Supply
- Reduced Power Consumption
- Thermal Shutdown Protection
- DS96F172 and DS96F174 are Lead and Function Compatible with the SN75172/174 or the AM26LS31/MC3487
- Military Temperature Range Available
- Qualified for MIL-STD-883C
- Standard Military Drawings Available (SMD)
- Available in CDIP (NFE), LCCC (NAJ), and CLGA (NAD) Packages

DESCRIPTION

The DS96F172 and the DS96F174 are high speed quad differential line drivers designed to meet EIA-485 Standards. The DS96F172 and the DS96F174 offer improved performance due to the use of L-FAST bipolar technology. The use of LFAST technology allows the DS96F172 and DS96F174 to operate at higher speeds while minimizing power consumption.

The DS96F172 and the DS96F174 have tri-state outputs and are optimized for balanced multipoint data bus transmission at rates up to 15 Mbps. The drivers have wide positive and negative common mode range for multipoint applications in noisy environments. Positive and negative current-limiting is provided which protects the drivers from line fault conditions over a $+12V$ to $-7.0V$ common mode range. A thermal shutdown feature is also provided. The DS96F172 features an active high and active low Enable, common to all four drivers. The DS96F174 features separate active high Enables for each driver pair.

Logic Diagrams

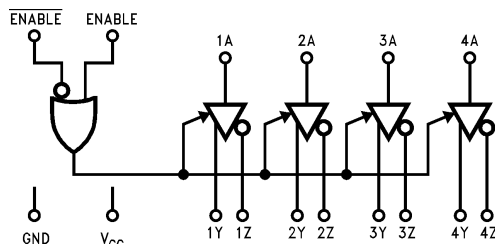

Figure 1. DS96F172

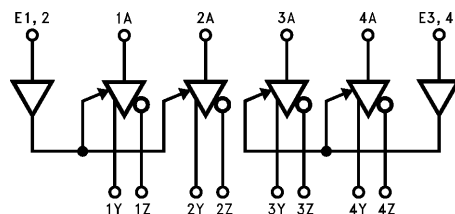

Figure 2. DS96F174



Please be aware that an important notice concerning availability, standard warranty, and use in critical applications of Texas Instruments semiconductor products and disclaimers thereto appears at the end of this data sheet.

All trademarks are the property of their respective owners.

Function Tables

(Each Driver)

Table 1. DS96F172⁽¹⁾

Input	Enable		Outputs	
	E	\bar{E}	Y	Z
H	H	X	H	L
L	H	X	L	H
H	X	L	H	L
L	X	L	L	H
X	L	H	Z	Z

- (1) H = High Level
 L = Low Level
 X = Don't Care
 Z = High Impedance (Off)

Table 2. DS96F174⁽¹⁾

Input	Enable	Outputs	
		Y	Z
H	H	H	L
L	H	L	H
X	L	Z	Z

- (1) H = High Level
 L = Low Level
 X = Don't Care
 Z = High Impedance (Off)



These devices have limited built-in ESD protection. The leads should be shorted together or the device placed in conductive foam during storage or handling to prevent electrostatic damage to the MOS gates.

Absolute Maximum Ratings **COMMERCIAL** ⁽¹⁾

Specifications for the 883 version of this product are listed separately on the following pages.

Storage Temperature Range (T_{STG})		-65°C to +175°C
Lead Temperature (Soldering, 60 sec.)		300°C
Maximum Package Power Dissipation ⁽²⁾ at 25°C	Ceramic DIP (NFE)	1500 mW
	Supply Voltage	7.0V
	Enable Input Voltage	5.5V

- (1) Absolute Maximum Ratings are those values beyond which the safety of the device cannot be ensured. They are not meant to imply that the devices should be operated at these limits. The tables of [Electrical Characteristics](#) provide conditions for actual device operation.
- (2) Derate "NFE" package 10 mW/°C above 25°C.

Recommended Operating Conditions

	Min	Typ	Max	Units
Supply Voltage (V_{CC}) DS96F174C	4.75	5.0	5.25	V
Common Mode Output Voltage (V_{OC})	-7.0		+12.0	V
Output Current HIGH (I_{OH})			-60	mA
Output Current LOW (I_{OL})			60	mA
Operating Temperature (T_A) DS96F174C	0		+70	°C

Electrical Characteristics⁽¹⁾⁽²⁾

Over recommended supply voltage and operating temperature range, unless otherwise specified

Symbol	Parameter	Conditions		Min	Typ ⁽³⁾	Max	Units
V _{IH}	Input Voltage HIGH			2.0			V
V _{IL}	Input Voltage LOW		T _A = 0°C to +70°C			0.8	V
			T _A = -55°C to +125°C			0.7	
V _{OH}	Output Voltage HIGH	I _{OH} = -33 mA	T _A = 0°C to +70°C	3.0			V
V _{OL}	Output Voltage LOW	I _{OL} = 33 mA	T _A = 0°C to +70°C			2.0	V
V _{IC}	Input Clamp Voltage	I _I = -18 mA				-1.5	V
V _{OD1}	Differential Output Voltage	I _O = 0 mA				6.0	V
V _{OD2}	Differential Output Voltage	R _L = 54Ω, See Figure 3	T _A = -55°C	1.2	2.0		V
				1.5			
		R _L = 100Ω, See Figure 3		2.0	2.3		
V _{OD}	Differential Output Voltage	See Figure 4	T _A = 0°C to +70°C	1.0			V
Δ V _{OD}	Change in Magnitude of Differential Output Voltage ⁽⁴⁾	R _L = 54Ω or 100Ω, Figure 3	-40°C to +125°C			±0.2	V
			-55°C to +125°C			±0.4	
V _{OC}	Common Mode Output Voltage ⁽⁵⁾	R _L = 54Ω or 100Ω, See Figure 3				3.0	V
Δ V _{OC}	Change in Magnitude of Common Mode Output Voltage ⁽⁴⁾	R _L = 54Ω or 100Ω, See Figure 3				±0.2	V
I _O	Output Current with Power Off	V _{CC} = 0V, V _O = -7.0V to +12V				±50	μA
I _{OZ}	High Impedance State Output Current	V _O = -7.0V to +12V			±20	±50	μA
I _{IH}	Input Current HIGH	V _I = 2.4V				20	μA
I _{IL}	Input Current LOW	V _I = 0.4V				-50	μA
I _{OS}	Short Circuit Output Current ⁽⁶⁾	V _O = -7.0V				-250	mA
		V _O = 0V				-150	
		V _O = V _{CC}				150	
		V _O = +12V				250	
I _{CC}	Supply Current (All Drivers)	No Load	Outputs Enabled			50	mA
			Outputs Disabled			30	

- (1) Unless otherwise specified min/max limits apply across the 0°C to +70°C range for the DS96F174C. All typicals are given for V_{CC} = 5V and T_A = 25°C.
- (2) All currents into the device pins are positive; all currents out of the device pins are negative. All voltages are reference to ground unless otherwise specified.
- (3) Absolute Maximum Ratings are those values beyond which the safety of the device cannot be ensured. They are not meant to imply that the devices should be operated at these limits. The tables of [Electrical Characteristics](#) provide conditions for actual device operation.
- (4) Δ|V_{OD}| and Δ|V_{OC}| are the changes in magnitude of V_{OD} and V_{OC} respectively, that occur when the input is changed from a high level to a low level.
- (5) In EIA-422A and EIA-485 standards, V_{OC}, which is the average of the two output voltages with respect to ground, is called output offset voltage, V_{OS}.
- (6) Only one output at a time should be shorted.

COMMERCIAL Switching Characteristics

 $V_{CC} = 5.0V$, $T_A = 25^\circ C$

Symbol	Parameter	Conditions	Min	Typ	Max	Units
t_{DD}	Differential Output Delay Time	$R_L = 60\Omega$, See Figure 5		15	20	ns
t_{TD}	Differential Output Transition Time			15	22	ns
t_{PLH}	Propagation Delay Time, Low-to-High Level Output	$R_L = 27\Omega$, See Figure 6		12	16	ns
t_{PHL}	Propagation Delay Time, High-to-Low Level Output			12	16	ns
t_{ZH}	Output Enable Time to High Level	$R_L = 110\Omega$, See Figure 6		25	32	ns
t_{ZL}	Output Enable Time to Low Level	$R_L = 110\Omega$, See Figure 8		25	32	ns
t_{HZ}	Output Disable Time from High Level	$R_L = 110\Omega$, See Figure 7		25	30	ns
t_{LZ}	Output Disable Time from Low Level	$R_L = 110\Omega$, See Figure 8		20	25	ns
t_{LZL}	Output Disable Time from Low Level with Load Resistor to GND	See Figure 8		300		ns
t_{SKEW}	Driver Output to Output	$R_L = 60\Omega$		1.0	4.0	ns

Absolute Maximum Ratings MIL-STD-883C⁽¹⁾

For complete Military Specifications, refer to the appropriate SMD or MDS.

Storage Temperature Range (T_{STG})		-65°C to +175°C
Lead Temperature (Soldering, 60 sec.)		300°C
Maximum Package Power Dissipation ⁽²⁾ at 25°C	Ceramic LCCC (NAJ)	2000 mW
	Ceramic DIP (NFE)	1800 mW
	Ceramic Flatpak (NAD)	1000 mW
	Supply Voltage	7.0V
	Enable Input Voltage	5.5V

- (1) Absolute Maximum Ratings are those values beyond which the safety of the device cannot be ensured. They are not meant to imply that the devices should be operated at these limits. The tables of [Electrical Characteristics](#) provide conditions for actual device operation.
- (2) Above $T_A = 25^\circ\text{C}$, derate "NAJ" package 13.4, "NFE" package 12.5, "NAD" package 7.1 mW/°C

Recommended Operating Conditions

	Min	Typ	Max	Units
Supply Voltage (V_{CC}) DS96F172M/DS96F174M	4.50	5.0	5.50	V
Common Mode Output Voltage (V_{OC})	-7.0		+12.0	V
Output Current HIGH (I_{OH})			-60	mA
Output Current LOW (I_{OL})			60	mA
Operating Temperature (T_A) DS96F172M/DS96F174M	-55		+125	°C

Electrical Characteristics⁽¹⁾⁽²⁾

Over recommended supply voltage and operating temperature range unless otherwise specified

Symbol	Parameter	Conditions		Min	Max	Units
V _{IH}	Input Voltage HIGH			2.0		V
V _{IL}	Input Voltage LOW	T _A = 25°C			0.8	V
		T _A = -55°C, or +125°C			0.7	
V _{IC}	Input Clamp Voltage	I _I = -18 mA			-1.5	V
V _{OD1}	Differential Output Voltage	I _O = 0 mA			6.0	V
V _{OD2}	Differential Output Voltage	R _L = 54Ω, V _{CC} = 4.5V See Figure 3	T _A = -55°C	1.2		V
			T _A = 25°C, or +125°C	1.5		
		R _L = 100Ω, V _{CC} = 4.5V, See Figure 3		2.0		
Δ V _{OD}	Change in Magnitude of Differential Output Voltage ⁽³⁾	R _L = 54Ω or 100Ω, V _{CC} = 4.5V, See Figure 3	T _A = 25°C, or +125°C		±0.2	V
			T _A = -55°C		±0.4	V
V _{OC}	Common Mode Output Voltage ⁽⁴⁾	R _L = 54Ω or 100Ω, See Figure 3			3.0	V
Δ V _{OC}	Change in Magnitude of Common Mode Output Voltage ⁽³⁾	R _L = 54Ω or 100Ω, V _{CC} = 4.5V, See Figure 3			±0.2	V
I _O	Output Current with Power Off	V _{CC} = 0V, V _O = -7.0V to +12V			±50	μA
I _{OZ}	High Impedance State Output Current	V _O = -7.0V to +12V			±50	μA
I _{IH}	Input Current HIGH	V _I = 2.4V			20	μA
I _{IL}	Input Current LOW	V _I = 0.4V			-50	μA
I _{OS}	Short Circuit Output Current ⁽⁵⁾	V _O = -7.0V			-250	mA
		V _O = 0V			-150	
		V _O = V _{CC}			150	
		V _O = +12V			250	
I _{CC}	Supply Current (All Drivers)	No Load	Outputs Enabled		50	mA
I _{CCX}			Outputs Disabled		30	

- (1) Unless otherwise specified min/max limits apply across the 0°C to +70°C range for the DS96F174C. All typicals are given for V_{CC} = 5V and T_A = 25°C.
- (2) All currents into the device pins are positive; all currents out of the device pins are negative. All voltages are reference to ground unless otherwise specified.
- (3) Δ|V_{OD}| and Δ|V_{OC}| are the changes in magnitude of V_{OD} and V_{OC} respectively, that occur when the input is changed from a high level to a low level.
- (4) In EIA-422A and EIA-485 standards, V_{OC}, which is the average of the two output voltages with respect to ground, is called output offset voltage, V_{OS}.
- (5) Only one output at a time should be shorted.

MIL-STD-883C
Switching Characteristics⁽¹⁾⁽²⁾
V_{CC} = 5.0V

Symbol	Parameter	Conditions	T _A = 25°C		T _A = 55°C	T _A = 125°C	Units
			Typ	Max	Max	Max	
t _{DD}	Differential Output Delay Time	R _L = 60Ω, C _L = 15 pF, See Figure 5	15	22	30	30	ns
t _{TD}	Differential Output Transition Time		15	22	40	40	ns
t _{PLH}	Propagation Delay Time, Low-to-High Level Output	R _L = 27Ω, C _L = 15 pF, See Figure 6	12	16	25	25	ns
t _{PHL}	Propagation Delay Time, High-to-Low Level Output		12	16	25	25	ns
t _{ZH}	Output Enable Time to High Level	R _L = 110Ω, See Figure 7	25	32	40	40	ns
t _{ZL}	Output Enable Time to Low Level	R _L = 110Ω, See Figure 8	25	35	100	100	ns
t _{HZ}	Output Disable Time from High Level	R _L = 110Ω, See Figure 7 , ⁽³⁾	25	30	80	80	ns
t _{LZ}	Output Disable Time from Low Level	R _L = 110Ω, See Figure 8	20	25	40	40	ns
t _{LZL}	Output Disable Time from Low Level with Load Resistor to GND	See Figure 8	300				ns
t _{SKEW}	Driver Output to Output	R _L = 60Ω	1.0	4.0	10	10	ns

(1) DS96F172 with active high and active low Enables is shown. DS96F174 has active high Enable only.

(2) To test the active low Enable \bar{E} of DS96F172 ground E and apply an inverted waveform to \bar{E} . DS96F174 has active high Enable only.

(3) Not tested for DS96F172MW-MIL device.

Parameter Measurement Information

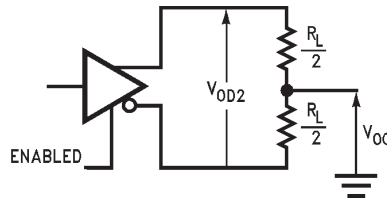

Figure 3. Differential and Common Mode Output Voltage⁽⁴⁾

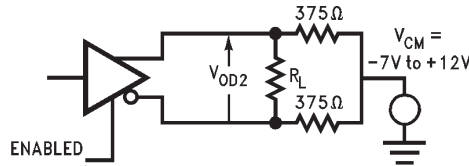

Figure 4. Differential Output Voltage with Varying Common Mode Voltage⁽⁴⁾

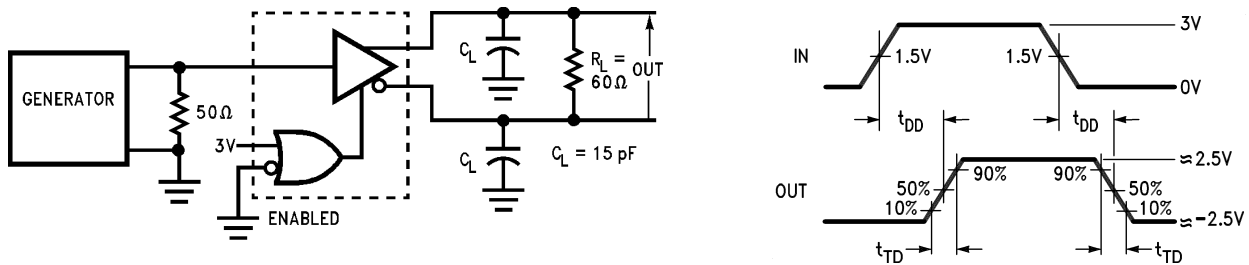

Figure 5. Differential Output Delay and Transition Times⁽⁵⁾⁽⁴⁾

- (4) The input pulse is supplied by a generator having the following characteristics: $f = 1.0 \text{ MHz}$, duty cycle = 50%, $t_r \leq 5.0 \text{ ns}$, $t_f \leq 5.0 \text{ ns}$, $Z_O = 50\Omega$.
- (5) Above $T_A = 25^\circ\text{C}$, derate "NAJ" package 13.4, "NFE" package 12.5, "NAD" package 7.1 mW/ $^\circ\text{C}$

Parameter Measurement Information (continued)

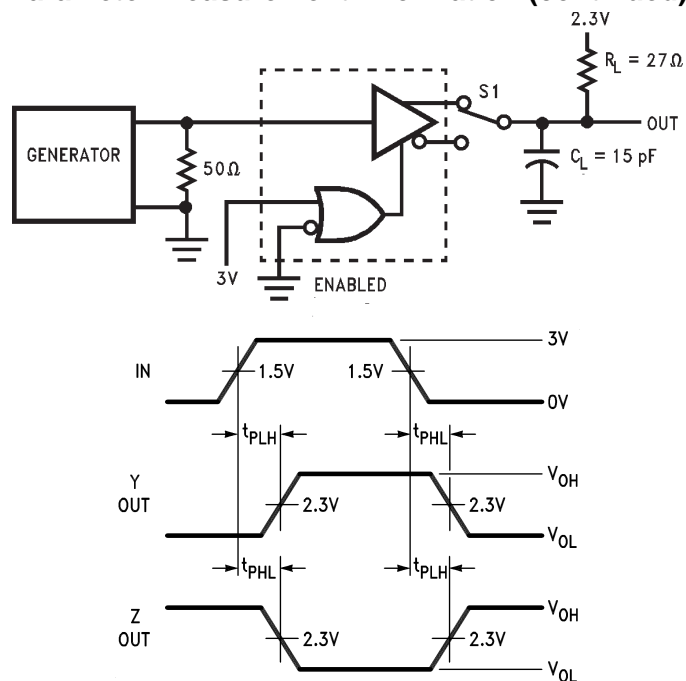

Figure 6. Propagation Delay Times ⁽⁶⁾⁽⁷⁾

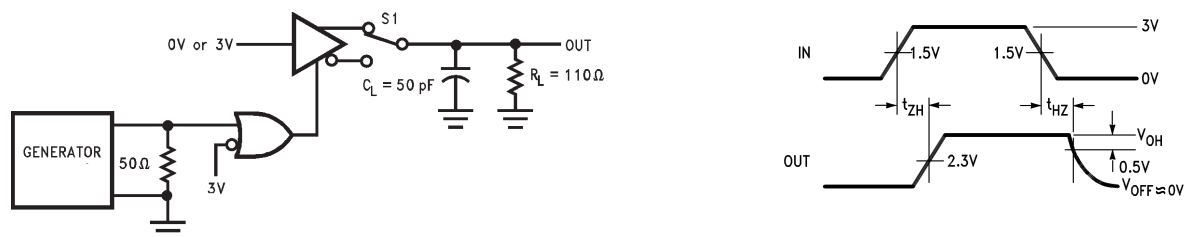

Figure 7. t_{ZH} and t_{HZ} ⁽⁶⁾⁽⁸⁾

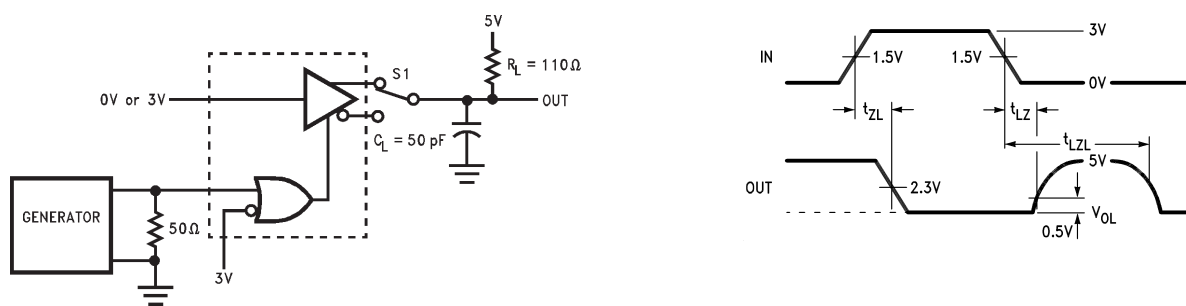

Figure 8. t_{ZL} , t_{LZ} , t_{LZL} ⁽⁶⁾⁽⁸⁾

(6) Above $T_A = 25^\circ\text{C}$, derate "NAJ" package 13.4, "NFE" package 12.5, "NAD" package 7.1 mW/ $^\circ\text{C}$

(7) The input pulse is supplied by a generator having the following characteristics: $f = 1.0$ MHz, duty cycle = 50%, $t_r \leq 5.0$ ns, $t_f \leq 5.0$ ns, $Z_0 = 50\Omega$.

(8) C_L includes probe and jig capacitance

TYPICAL APPLICATION

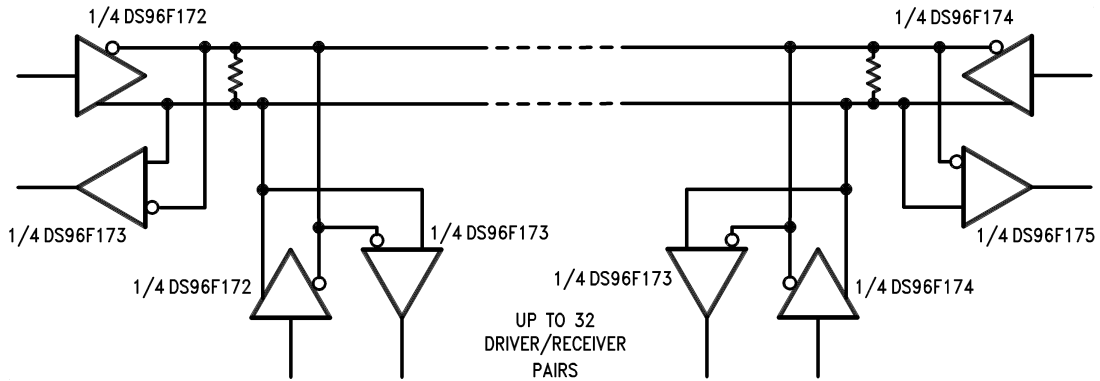

NOTE

The line length should be terminated at both ends in its characteristic impedance. Stub lengths off the main line should be kept as short as possible.

Connection Diagrams

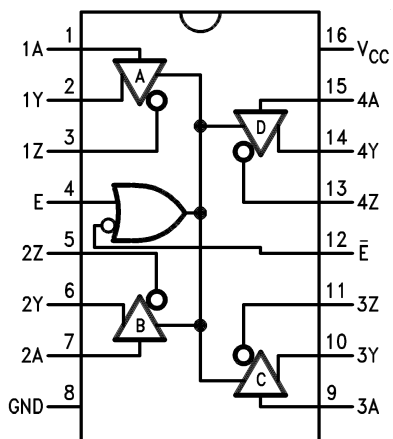

Figure 9. DS96F172 (Top View)
CDIP - 16-Lead Ceramic Dual-In-Line Package
 See Package Number NFE

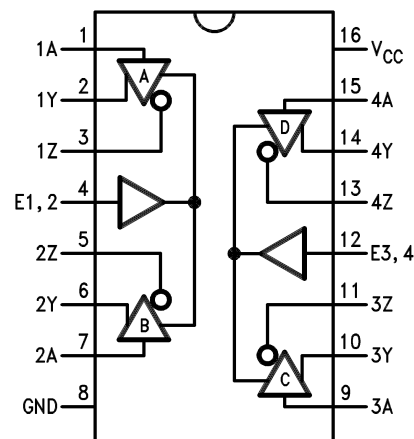
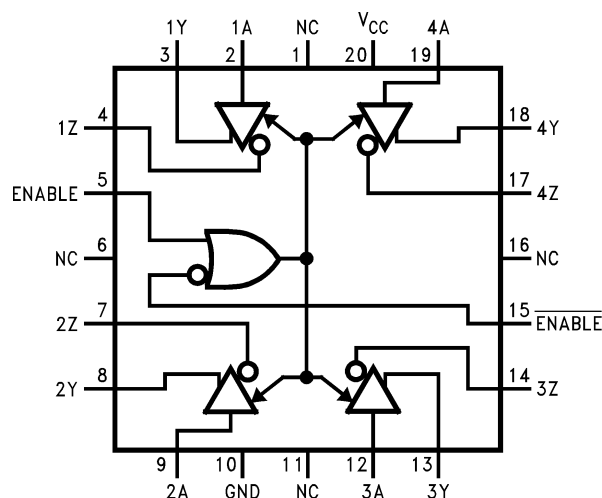
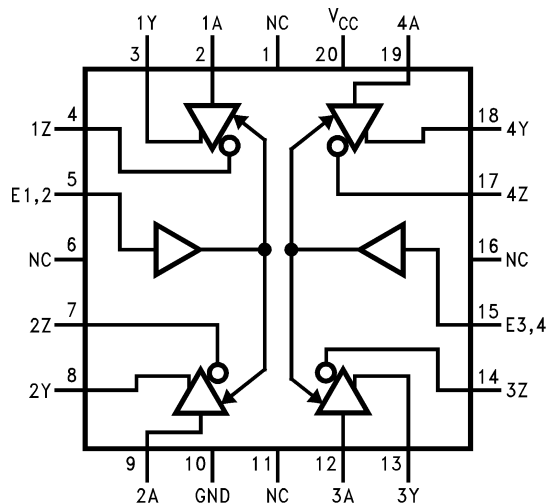

Figure 10. DS96F174 (Top View)
CDIP - 16-Lead Ceramic Dual-In-Line Package
 See Package Number NFE



NC = No connection

Figure 11. 20-Lead Ceramic Leadless Chip Carrier - LCCC (Top View)
 See Package Number NAJ



NC = No connection

Figure 12. 20-Lead Ceramic Leadless Chip Carrier - LCCC (Top View)
See Package Number NAJ

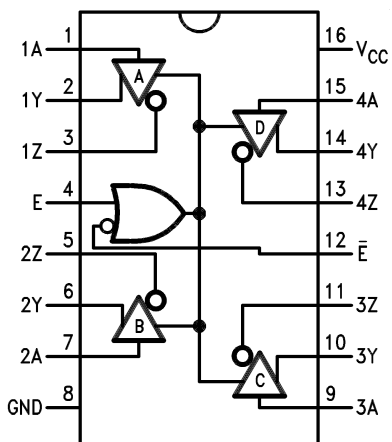

Figure 13. 16-Lead Ceramic Flatpack - CLGA (Top View)
See Package Number NAD

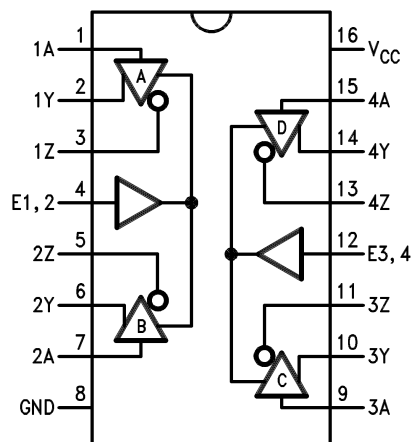

Figure 14. 16-Lead Ceramic Flatpack - CLGA (Top View)
See Package Number NAD

REVISION HISTORY

Changes from Revision E (April 2013) to Revision F

Page

-
- Changed layout of National Data Sheet to TI format [13](#)
-

IMPORTANT NOTICE

Texas Instruments Incorporated and its subsidiaries (TI) reserve the right to make corrections, enhancements, improvements and other changes to its semiconductor products and services per JESD46, latest issue, and to discontinue any product or service per JESD48, latest issue. Buyers should obtain the latest relevant information before placing orders and should verify that such information is current and complete. All semiconductor products (also referred to herein as "components") are sold subject to TI's terms and conditions of sale supplied at the time of order acknowledgment.

TI warrants performance of its components to the specifications applicable at the time of sale, in accordance with the warranty in TI's terms and conditions of sale of semiconductor products. Testing and other quality control techniques are used to the extent TI deems necessary to support this warranty. Except where mandated by applicable law, testing of all parameters of each component is not necessarily performed.

TI assumes no liability for applications assistance or the design of Buyers' products. Buyers are responsible for their products and applications using TI components. To minimize the risks associated with Buyers' products and applications, Buyers should provide adequate design and operating safeguards.

TI does not warrant or represent that any license, either express or implied, is granted under any patent right, copyright, mask work right, or other intellectual property right relating to any combination, machine, or process in which TI components or services are used. Information published by TI regarding third-party products or services does not constitute a license to use such products or services or a warranty or endorsement thereof. Use of such information may require a license from a third party under the patents or other intellectual property of the third party, or a license from TI under the patents or other intellectual property of TI.

Reproduction of significant portions of TI information in TI data books or data sheets is permissible only if reproduction is without alteration and is accompanied by all associated warranties, conditions, limitations, and notices. TI is not responsible or liable for such altered documentation. Information of third parties may be subject to additional restrictions.

Resale of TI components or services with statements different from or beyond the parameters stated by TI for that component or service voids all express and any implied warranties for the associated TI component or service and is an unfair and deceptive business practice. TI is not responsible or liable for any such statements.

Buyer acknowledges and agrees that it is solely responsible for compliance with all legal, regulatory and safety-related requirements concerning its products, and any use of TI components in its applications, notwithstanding any applications-related information or support that may be provided by TI. Buyer represents and agrees that it has all the necessary expertise to create and implement safeguards which anticipate dangerous consequences of failures, monitor failures and their consequences, lessen the likelihood of failures that might cause harm and take appropriate remedial actions. Buyer will fully indemnify TI and its representatives against any damages arising out of the use of any TI components in safety-critical applications.

In some cases, TI components may be promoted specifically to facilitate safety-related applications. With such components, TI's goal is to help enable customers to design and create their own end-product solutions that meet applicable functional safety standards and requirements. Nonetheless, such components are subject to these terms.

No TI components are authorized for use in FDA Class III (or similar life-critical medical equipment) unless authorized officers of the parties have executed a special agreement specifically governing such use.

Only those TI components which TI has specifically designated as military grade or "enhanced plastic" are designed and intended for use in military/aerospace applications or environments. Buyer acknowledges and agrees that any military or aerospace use of TI components which have **not** been so designated is solely at the Buyer's risk, and that Buyer is solely responsible for compliance with all legal and regulatory requirements in connection with such use.

TI has specifically designated certain components as meeting ISO/TS16949 requirements, mainly for automotive use. In any case of use of non-designated products, TI will not be responsible for any failure to meet ISO/TS16949.

Products

Audio	www.ti.com/audio
Amplifiers	amplifier.ti.com
Data Converters	dataconverter.ti.com
DLP® Products	www.dlp.com
DSP	dsp.ti.com
Clocks and Timers	www.ti.com/clocks
Interface	interface.ti.com
Logic	logic.ti.com
Power Mgmt	power.ti.com
Microcontrollers	microcontroller.ti.com
RFID	www.ti-rfid.com
OMAP Applications Processors	www.ti.com/omap
Wireless Connectivity	www.ti.com/wirelessconnectivity

Applications

Automotive and Transportation	www.ti.com/automotive
Communications and Telecom	www.ti.com/communications
Computers and Peripherals	www.ti.com/computers
Consumer Electronics	www.ti.com/consumer-apps
Energy and Lighting	www.ti.com/energy
Industrial	www.ti.com/industrial
Medical	www.ti.com/medical
Security	www.ti.com/security
Space, Avionics and Defense	www.ti.com/space-avionics-defense
Video and Imaging	www.ti.com/video

TI E2E Community

e2e.ti.com