

## LP3927 Cellular/PCS System Power Management IC

Check for Samples: [LP3927](#)

### FEATURES

- 3.0V to 5.5V Input Voltage Range
- Two 200 mA, Two 150 mA and One 100 mA LDO's
- 100 mV typ Dropout Voltage @  $I_{MAX}$
- 150 mA General-Purpose Open-Drain Programmable Current Sink for Back Light LED
- Low Voltage Rail to Rail Input/Output Operational Amplifier
- 28 pin WQFN Package

### APPLICATIONS

- Cellular/PCS Handsets
- PDA's, Palmtops, and Portable Terminals
- Single-Cell Li+ Systems
- 2- or 3- Cell NiMH, NiCd or Alkaline System

### DESCRIPTION

The LP3927 system power management IC is designed for cellular/PCS handsets as well as other portable systems that require intelligent power management. Each device contains five low-dropout linear regulators (LDO's), a reset timer, a power-up control logic, a general-purpose open drain output that can be used to light LEDs, and a CMOS rail-to-rail input/output operational amplifier.

Each linear regulator features an extremely low dropout voltage of 100 mV (typ) at maximum output current. LDO1 and LDO2 are powered on and off by either the KYBD or the VEXT pin. LDO3, LDO4 and LDO5 each have its independent enable pin. LDO1 and LDO4 are rated at 150 mA each, LDO2 and LDO5 are rated at 200 mA each and LDO3 is rated at 100 mA. All LDO's are optimized for low noise and high isolation.

The open drain output current sink can be programmed up to 150 mA by using an external low cost resistor.

A single supply, low voltage operational amplifier has rail to rail input and output with 600 kHz of gain-bandwidth product.

### Typical Application Circuit

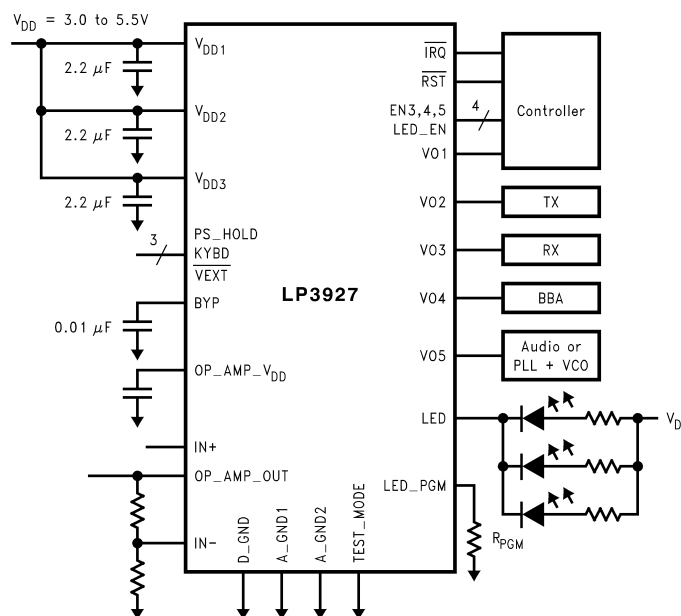

NOTE:  $V_{DD1}$ ,  $V_{DD2}$  and  $V_{DD3}$  must be tied together externally. Collectively called  $V_{DD}$ .



Please be aware that an important notice concerning availability, standard warranty, and use in critical applications of Texas Instruments semiconductor products and disclaimers thereto appears at the end of this data sheet.

All trademarks are the property of their respective owners.

### LP3927 Pin Out Diagram (Top View)

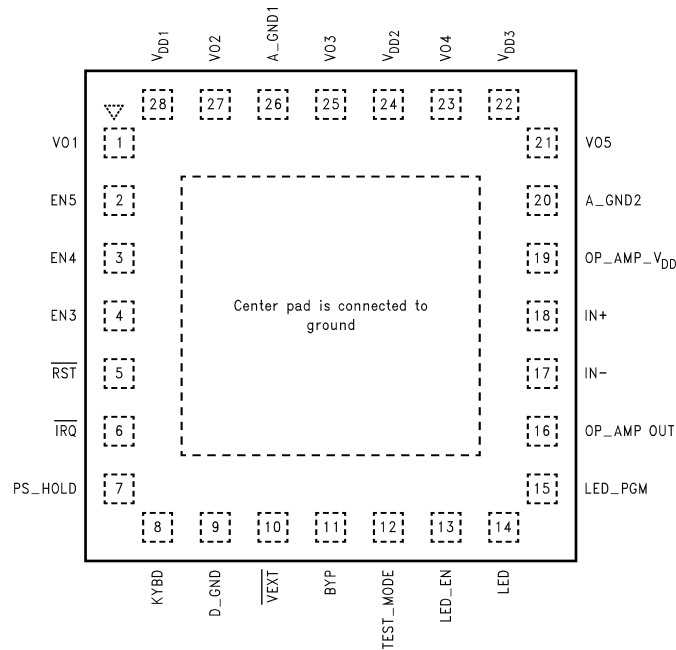

### Output Current Rating and Voltage Options

	<b>I<sub>MAX</sub> (mA)</b>	<b>Voltage Options (V)</b>
LDO1	150	1.8, 1.9, 2.5, 2.6 <sup>(1)</sup> , 2.7
LDO2	200	1.8, 2.85 <sup>(1)</sup> , 2.9, 3.0
LDO3	100	2.7, 2.8, 2.9 <sup>(1)</sup> , 3.0
LDO4	150	2.7, 2.8, 2.9 <sup>(1)</sup> , 3.0
LDO5	200	2.7, 2.8, 2.9, 3.0 <sup>(1)</sup>

(1) Denotes the voltage options that are available currently. For other options, please contact the TI factory sales office/distributors for availability and specifications. Voltage options in the tables cannot be mixed and matched.

	<b>I<sub>MAX</sub> (mA)</b>	<b>Voltage Options (V)</b>
LDO1	150	1.85 <sup>(1)</sup> , 1.9, 2.5, 2.6, 2.7
LDO2	200	1.8, 2.85 <sup>(1)</sup> , 2.9, 3.0
LDO3	100	2.7, 2.85 <sup>(1)</sup> , 2.9, 3.0
LDO4	150	2.6 <sup>(1)</sup> , 2.85, 2.9, 3.0
LDO5	200	2.7, 2.85 <sup>(1)</sup> , 2.9, 3.0

(1) Denotes the voltage options that are available currently. For other options, please contact the TI factory sales office/distributors for availability and specifications. Voltage options in the tables cannot be mixed and matched.

	<b>I<sub>MAX</sub> (mA)</b>	<b>Voltage Options (V)</b>
LDO1	150	1.85 <sup>(1)</sup> , 1.9, 2.5, 2.6, 2.7
LDO2	200	1.8, 2.85, 2.9, 3.0 <sup>(1)</sup>
LDO3	100	2.7, 2.85, 2.9, 3.0 <sup>(1)</sup>
LDO4	150	2.6, 2.85, 2.9, 3.0 <sup>(1)</sup>
LDO5	200	2.7, 2.85, 2.9, 3.0 <sup>(1)</sup>

(1) Denotes the voltage options that are available currently. For other options, please contact the TI factory sales office/distributors for availability and specifications. Voltage options in the tables cannot be mixed and matched.

**Table 1. Pin Descriptions**

Pin	Name	Functional Description
1	VO1	150 mA, LDO1 output pin.
2	EN5	LDO5 enable input.
3	EN4	LDO4 enable input.
4	EN3	LDO3 enable input.
5	RST	Externally pulled high, open drain output to processor/memory reset.
6	IRQ	Externally pulled high, open drain output to processor interrupt indicating KYBD has gone high.
7	PS_HOLD	Input from the processor to the LP3927. A HIGH indicates a steady supply of power is granted. Refer to <a href="#">Application Hints</a> for more detail.
8	KYBD	An active high input signal indicating the keyboard "On/Off" button has been asserted. Refer to "Application Hints" section for more detail.
9	D_GND	Digital ground, used primarily for the digital and DAC circuits.
10	VEXT	Active low input indicating a battery charger insertion Refer to "Application Hints" section for more detail.
11	BYP	Reference bypass pin.
12	TEST_MODE	Pin used for production testing, factory use only. This pin should be grounded in applications.
13	LED_EN	LED driver enable input.
14	LED	LED driver, drain connection of the LED drive MOSFET.
15	LED_PGM	LED drive current programming pin.
16	OP_AMP_OUT	Operational amplifier output pin.
17	IN-	- input of the Op-Amp.
18	IN+	+ input of the Op-Amp.
19	OP_AMP_VDD	Power supply pin for Op-Amp.
20	A_GND2	Ground for analog.
21	VO5	200 mA, LDO5 output pin.
22	VDD3	Input power pin for LDO5. VDD1, VDD2 and VDD3 must be tied together externally.
23	VO4	150 mA, LDO4 output pin.
24	VDD2	Input power pin for LDO3 and LDO4. VDD1, VDD2 and VDD3 must be tied together externally.
25	VO3	100 mA, LDO3 output pin.
26	A_GND1	Ground for analog.
27	VO2	200 mA, LDO2 output pin.
28	VDD1	Input power pin for LDO1 and LDO2. VDD1, VDD2 and VDD3 must be tied together externally.

**FUNCTIONAL BLOCK DIAGRAM**

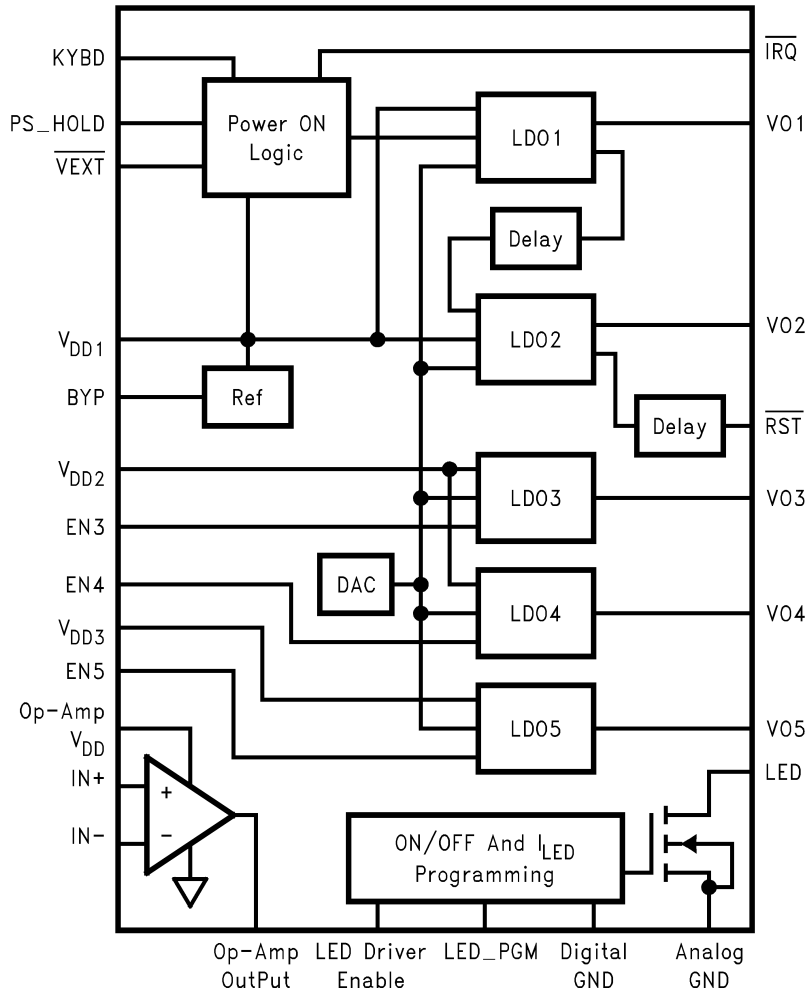

These devices have limited built-in ESD protection. The leads should be shorted together or the device placed in conductive foam during storage or handling to prevent electrostatic damage to the MOS gates.

**Absolute Maximum Ratings<sup>(1)(2)(3)</sup>**

All pins except LED_PGM, BYP, op amp's inputs & output	-0.3V to 6.0V
OP_AMP_OUT, IN-, IN+	-0.3V to 5.5V
GND to GND SLUG	±0.3V
Junction Temperature	150°C
Storage Information	-65°C to 150°C
Soldering Temperature, Pad Temperature	235°C
Maximum Power Dissipation <sup>(4)</sup>	2.6W
ESD <sup>(5)</sup> :	
KYBD	4 kV
All other pins	2 kV

- (1) All voltages are with respect to the potential at the GND pin.
- (2) Absolute Maximum Ratings are limits beyond which damage to the device may occur. Operating Ratings are conditions under which operation of the device is guaranteed. Operating Ratings do not imply guaranteed performance limits. For guaranteed performance limits and associated test conditions, see the Electrical Characteristics tables.
- (3) If Military/Aerospace specified devices are required, please contact the TI Sales Office/Distributors for availability and specifications.
- (4) The Absolute Maximum power dissipation depends on the ambient temperature and can be calculated using the formula  $P = (T_J - T_A)/\theta_{JA}$ , where  $T_J$  is the junction temperature,  $T_A$  is the ambient temperature, and  $\theta_{JA}$  is the junction-to-ambient thermal resistance. The 2.6W rating appearing under Absolute Maximum Ratings results from substituting the Absolute Maximum junction temperature, 150°C, for  $T_J$ , 70°C for  $T_A$ , and 30.8°C/W for  $\theta_{JA}$ . More power can be dissipated safely at ambient temperatures below 70°C. Less power can be dissipated safely at ambient temperatures above 70°C. The Absolute Maximum power dissipation can be increased by 32.5 mW for each degree below 70°C, and it must be derated by 32.5 mW for each degree above 70°C.
- (5) The human-body model is used. The human-body model is 100 pF discharged through 1.5 kΩ.

**Operating Ratings<sup>(1)(2)</sup>**

$V_{DD1}$ , $V_{DD2}$ , $V_{DD3}$ , KYBD, OP_AMP_ $V_{DD}$	3.0V to 5.5V
EN3, EN4, EN5	-0.3V to ( $V_{DD} + 0.3V$ )
$C_{OUT}$ :	
Capacitance	1.0 $\mu$ F to 20.0 $\mu$ F
ESR	0.005 $\Omega$ to 0.5 $\Omega$
Junction Temperature	-40°C to 125°C
Operating Temperature	-40°C to 85°C
Thermal Resistance <sup>(3)</sup>	
$\theta_{JA}$ (WQFN28)	30.8°C/W
Maximum Power Dissipation <sup>(4)</sup>	1.78W

- (1) Absolute Maximum Ratings are limits beyond which damage to the device may occur. Operating Ratings are conditions under which operation of the device is guaranteed. Operating Ratings do not imply guaranteed performance limits. For guaranteed performance limits and associated test conditions, see the Electrical Characteristics tables.
- (2) All voltages are with respect to the potential at the GND pin.
- (3) This figure is taken from a thermal modeling result. The test board is a 4 layer FR-4 board measuring 101mm x 101mm x 1.6mm with a 3 x 3 array of thermal vias. The ground plane on the board is 50mm x 50mm. Ambient temperature in simulation is 22°C, still air. Power dissipation is 1W.
- (4) Like the Absolute Maximum power dissipation, the maximum power dissipation for operation depends on the ambient temperature. The 1.78W rating appearing under Operating Ratings results from substituting the maximum junction temperature for operation, 125°C, for  $T_J$ , 70°C for  $T_A$ , and 30.8°C/W for  $\theta_{JA}$  into  $P = (T_J - T_A)/\theta_{JA}$ . More power can be dissipated at ambient temperatures below 70°C. Less power can be dissipated at ambient temperatures above 70°C. The maximum power dissipation for operation can be increased by 32.5 mW for each degree below 70°C, and it must be derated by 32.5 mW for each degree above 70°C.

## Electrical Characteristics, LDO's

Unless otherwise noted,  $V_{DD} = V_{OUT(target)} + 0.7V$ ,  $C_{IN} (V_{DD1}, V_{DD2}, V_{DD3}) = 4.7 \mu F$ ,  $C_{OUT} (VO1 \text{ to } VO5) = 2.2 \mu F$ ,  $C_{byp} = 0.1 \mu F$ . Typical values and limits appearing in normal type apply for  $T_J = 25^\circ C$ . Limits appearing in **boldface** type apply over the entire junction temperature range for operation,  $-40^\circ C$  to  $+85^\circ C$ . <sup>(1)</sup> <sup>(2)</sup>

Symbol	Parameter	Conditions	Typical	Limit		Units
				Min	Max	
$V_{DD}$	Input Voltage Range	$V_{DD1}, V_{DD2}, V_{DD3}, KYBD$	3.7	3	5.5	V
$\Delta V_{OUT}$	Output Voltage Tolerance	$I_{OUT} = I_{MAX}/2$ , $V_{DD} = 3.7V$		<b>-2</b>	<b>+2</b>	%
	Load Regulation	$I_{OUT} = 100 \mu A$ to $I_{MAX}$ , $V_{DD} = 3.7V$		<b>-2</b>	<b>+2</b>	%
	Line Regulation	$V_{DD} = V_{OUT(target)} + 0.7V$ to $5.5V$ $I_{OUT} = I_{MAX}/2$		<b>-40</b>	<b>+40</b>	mV
	Total Accuracy Error			<b>-3.5</b>	<b>+3.5</b>	%
$V_{IN} - V_{OUT}$	Dropout Voltage	$I_{OUT} = I_{MAX}^{(3)}$	100		<b>170</b> <b>200</b>	mV
$e_N$	Output Noise Voltage	$I_{OUT} = 100 \mu A$ , $10 \text{ Hz} \leq f \leq 100 \text{ kHz}$	27			$\mu V_{rms}$
PSRR	Power Supply Ripple Rejection Ratio	$C_{IN} = 2.2 \mu F$ , $I_{OUT} = I_{MAX}$ , $f = 100 \text{ Hz}$ $f = 1 \text{ kHz}$ $f = 10 \text{ kHz}$ $f = 100 \text{ kHz}$	45			dB
			45 30 10			
	Cross Talk	<sup>(4)</sup>	30			dB
$I_Q$	Quiescent Current	$I_{OUT} = 0$ , $PS\_HOLD = KYBD = 0$ $V_{EXT} = V_{DD}$			<b>5</b> <b>8</b>	$\mu A$
$I_{GND}$	Ground Current	$I_{OUT1} = I_{OUT2} = 1 \text{ mA}$ , LDO3, LDO4, LDO5 OFF	100		<b>200</b>	$\mu A$
			400		<b>950</b>	
$I_{SC}$	Short Circuit Current Limit	$V_{OUT} = 0V$	400			% of $I_{MAX}$
$C_{OUT}$	Output Capacitor	Capacitance		<b>1</b>	<b>20</b>	$\mu F$
		ESR		<b>5</b>	<b>500</b>	m $\Omega$
$R_{SHUNT}$	$V_{O2} - V_{O5}$ Output Shunt Resistor		70		<b>200</b>	$\Omega$

- (1) All limits guaranteed at room temperature and at **temperature extremes**. All room temperature limits are 100% production tested or guaranteed through statistical analysis. All limits at temperature extremes are guaranteed via correlation using standard Statistical Quality Control (SQC) methods.
- (2) The target output voltage, which is labeled  $V_{OUT(target)}$ , is the desired or ideal output voltage.
- (3) Dropout voltage is the input-to-output voltage difference at which the output voltage is 100 mV below its nominal value. This specification does not apply in cases it implies operation with an input voltage below the 2.5V minimum appearing under Operating Ratings. For example, this specification does not apply for devices having 1.5V outputs because the specification would imply operation with an input voltage at or about 1.5V.
- (4) Pulsing the load of LDO X from  $100 \mu A$  to  $I_{MAX}$  and measuring its effects at the output of LDO Y. LDO Y enabled but under no load.

**Electrical Characteristics, Digital Interface**

Symbol	Parameter	Conditions	Typical	Limit		Units
				Min	Max	
V <sub>OL</sub>	Logic Low Output	$\overline{RST}$ and $\overline{IRQ}$ I <sub>LOAD</sub> = 250 $\mu$ A			<b>150</b>	mV
V <sub>IH</sub>	Logic High Input	KYBD and $\overline{VEXT}$		0.7 V <sub>DD</sub>		V
		EN3–5, PS_HOLD		1.4		
		LED_EN for AH and AJ options		0.85V <sub>DD</sub>		
		LED_EN for AP and AZ options		2.0		
V <sub>IL</sub>	Logic Low Input	KYBD and $\overline{VEXT}$			0.2 V <sub>DD</sub>	V
		EN3–5, PS_HOLD			0.4	
		LED_EN for AH and AJ options			0.2 V <sub>DD</sub>	
		LED_EN for AP and AZ options			0.4	
I <sub>LEAKAGE</sub>	Input Leakage Current	$\overline{VEXT}$ , PS_HOLD, $\overline{IRQ}$ , KYBD, EN3–5, 0V $\leq$ V <sub>DD</sub> $\leq$ 5.5V		<b>–10</b>	<b>+10</b>	$\mu$ A

**Electrical Characteristics, Error Flag**

Symbol	Parameter	Conditions	Typical	Limit		Units
				Min	Max	
V <sub>Th-H</sub>	Error Flag High	V <sub>o1</sub> and V <sub>o2</sub> Outputs <sup>(1)</sup>	95	92	98	% V <sub>OUT</sub>
V <sub>Th-L</sub>	Error Flag Low		90	89	92	
t <sub>DELAY-H</sub>		<sup>(2)</sup>	6	0	10	$\mu$ s
t <sub>DELAY-L</sub>			6	0	10	$\mu$ s
	Keyboard Debounce Delay	<sup>(3)</sup>	32	16	64	ms
	$\overline{VEXT}$ Debounce Delay	<sup>(3)</sup>	32	16	64	ms
R <sub>DELAY</sub>	$\overline{RST}$ Reset Delay	<sup>(4)</sup>	20	10	40	ms
t <sub>DELAY</sub>	LDO Delay, standard	<sup>(5)</sup>	125	0	250	$\mu$ s
	LDO Delay, optional		10	5	20	ms
t <sub>Hold-UP</sub>	PS_HOLD Input	<sup>(6)</sup>	500	250	1000	ms

- (1) The error flags are internal to the chip. There is no external access to the signals. LDO1 error flag and the LDO2 error flag will go HIGH when the respective LDO reaches its V<sub>Th-H</sub> value. The error flags will go LOW when the respective LDO reaches its V<sub>Th-L</sub> value.
- (2) The t<sub>DELAY-H</sub> is the delay between LDO1 reaching its V<sub>Th-H</sub> and its error flag going HIGH. The t<sub>DELAY-L</sub> is the delay between LDO1 reaching its V<sub>Th-L</sub> and its error flag going LOW. Same delays apply to LDO2 and its error flag.
- (3) Refer to [Timing Diagrams](#).
- (4) The delay between LDO2 error flag HIGH and  $\overline{RST}$  signal HIGH in the power up sequence. In the power down sequence, it is the delay between  $\overline{RST}$  signal LOW and LDO2 disabled.
- (5) The delay between LDO1 error flag HIGH and LDO2 enable in power up sequence. In the power down sequence, it is the delay between LDO2 error flag LOW and LDO1 disable. For the optional LDO delay, please contact the factory for availability.
- (6) Time between  $\overline{RST}$  high and PS\_HOLD going high.

**Electrical Characteristics, Backlight LED Driver**

Symbol	Parameter	Conditions	Typical	Limit		Units
				Min	Max	
I <sub>LED</sub>	Drive Current	V <sub>LED</sub> = 1V, R <sub>PGM</sub> = 130k $\Omega$	150	125	175	mA

## Electrical Characteristics, Operational Amplifier

Unless otherwise noted,  $V_{OP\_AMP\_VDD} = 3.3V$ ,  $V_{CM} = V_{OUT} = V_{OP\_AMP\_VDD}/2$  and  $R_{LOAD} > 1\ M\Omega$ . Typical values and limits appearing in normal type apply for  $T_J = 25^\circ C$ . Limits appearing in **boldface** type apply over the entire junction temperature range for operation,  $-40^\circ C$  to  $+85^\circ C$ . <sup>(1)</sup>

Symbol	Parameter	Conditions	Typical	Limit		Units
				Min	Max	
$V_{DD}$	OP_AMP_VDD		3.3	3	5.5	V
$V_{OS}$	Input Offset Voltage		1.2		10	mV
TC $V_{OS}$	Offset Voltage Drift		10			$\mu V/^\circ C$
$I_B$	Input Bias Current		0.2			nA
$I_{OS}$	Input Offset Current		0.1			nA
$R_{IN}$	Input Resistance		>1			G $\Omega$
CMRR	Common-Mode Rejection Ratio	$0V \leq V_{CM} \leq 2.7V$	70			dB
PSRR	Power Supply Rejection Ratio	$V_{OP\_AMP\_VDD} = 2.7V$ to $3.3V$ , $V_{CM} = 0$	60			dB
$C_{IN}$	Common-Mode Input Capacitor		3			pF
$V_{OUT}$	Output Swing	$R_{LOAD} = 2\ k\Omega$			<b>0.5</b>	V
				<b>3.1</b>		
$I_S$	Supply Current	$V_{OP\_AMP\_VDD} = 3.0V$	0.5		<b>1.4</b>	mA
SR	Slew Rate		0.7			V/ $\mu s$
GBW	Gain-Bandwidth Product		0.6			MHz

- (1) All limits guaranteed at room temperature and at **temperature extremes**. All room temperature limits are 100% production tested or guaranteed through statistical analysis. All limits at temperature extremes are guaranteed via correlation using standard Statistical Quality Control (SQC) methods.



### Typical Performance Characteristics

Unless otherwise specified,  $C_{IN} = 1 \mu\text{F}$  ceramic,  $C_{BYP} = 0.01 \mu\text{F}$ ,  $V_{DD} = V_{OUT} + 0.2\text{V}$ ,  $T_A = 25^\circ\text{C}$ , Enable pin is tied to  $V_{DD}$ .

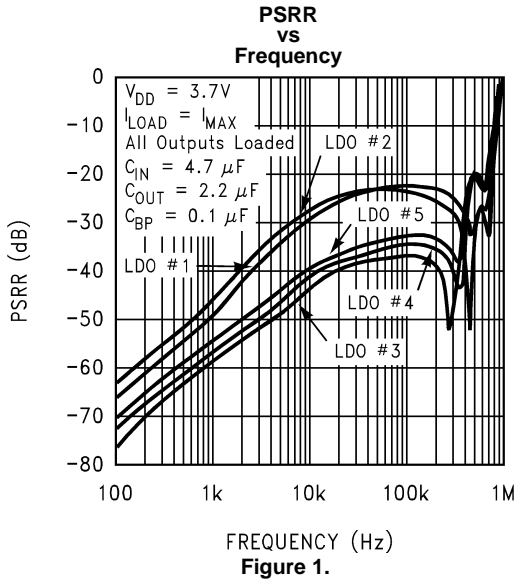

Figure 1.

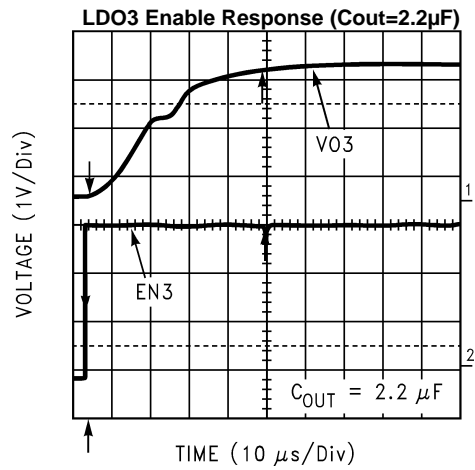

Figure 2.

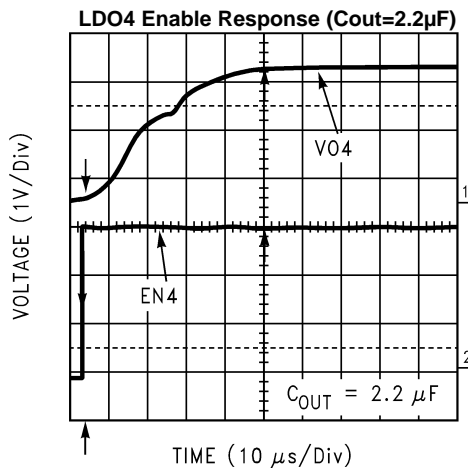

Figure 3.

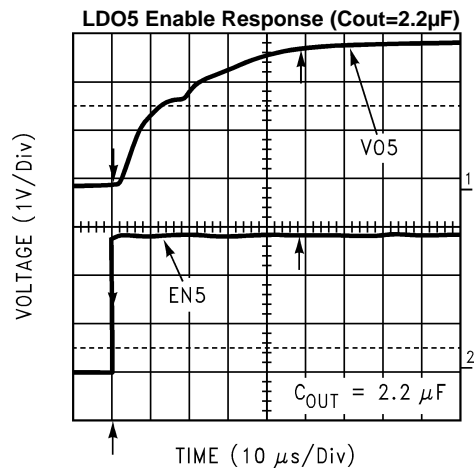

Figure 4.

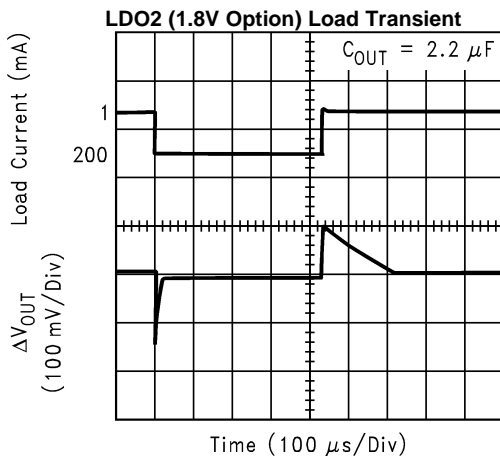

Figure 5.

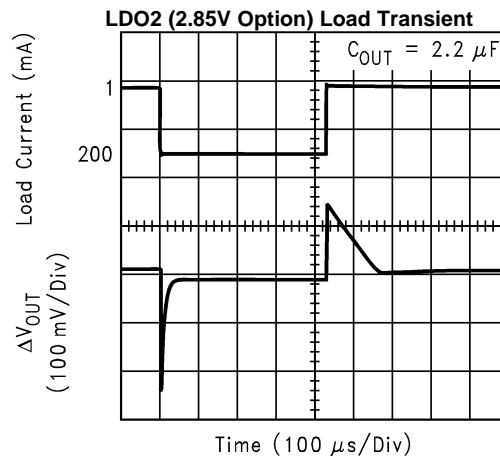

Figure 6.

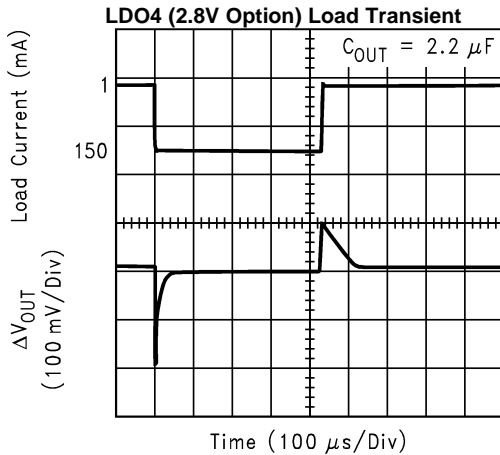

Figure 7.

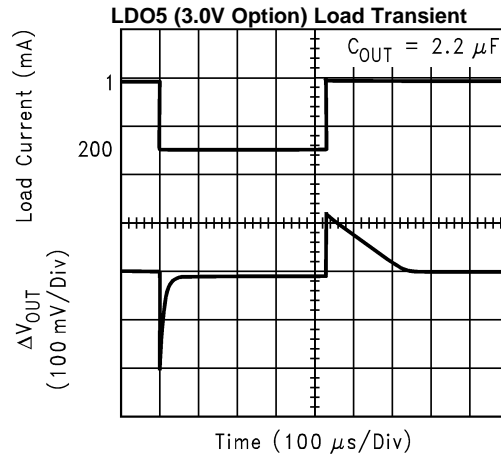

Figure 8.

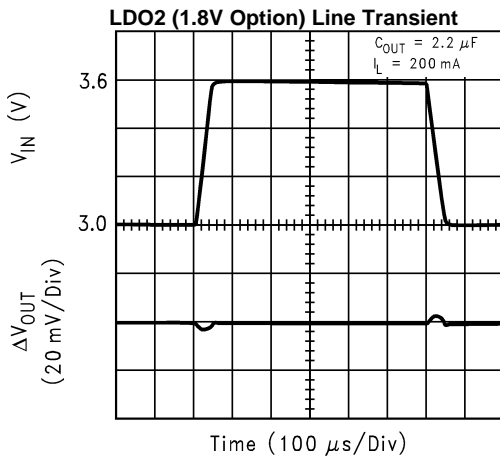

Figure 9.

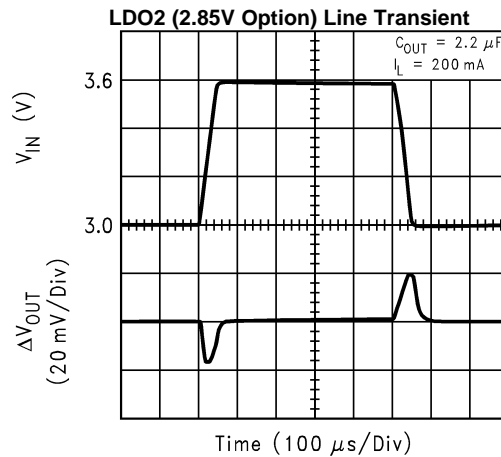

Figure 10.

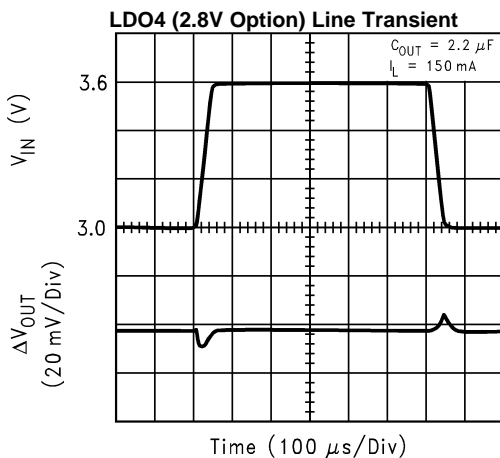

Figure 11.

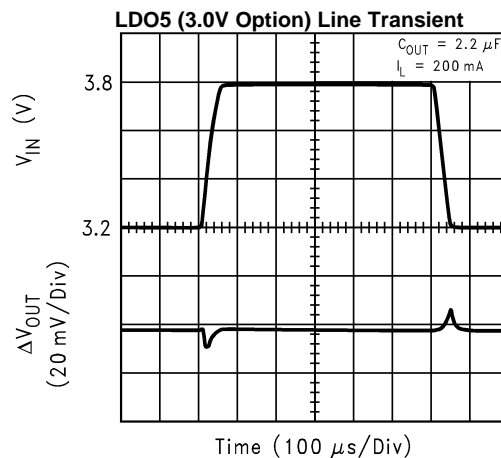
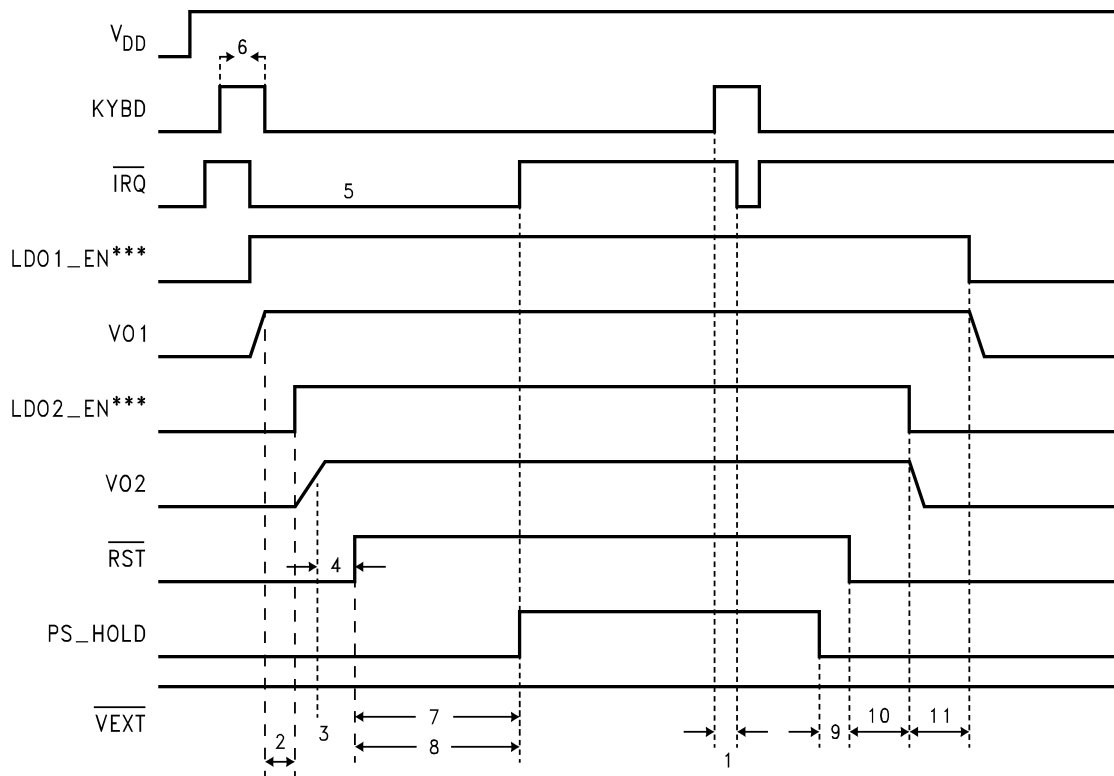

Figure 12.

TIMING DIAGRAMS



**Note:** Diagram indicates Open Drain  $\overline{\text{IRQ}}$  tied to V<sub>DD</sub>.  
\*\*\* = Internal signal

**Figure 13. Keyboard Start-Up/Shut-Down**

1. Keyboard de-bounce delay, 32 msec typ.
2. Delay between LDO1 reaching 95% of its output voltage and LDO2 enable, 125  $\mu$ sec typical.
3. Both LDO1 and LDO2 outputs reach 95% of respective output voltage, start  $\overline{\text{RST}}$  timer.
4.  $\overline{\text{RST}}$  delay, 20 msec typical.
5.  $\overline{\text{IRQ}}$  is active low.
6. Keyboard press must be greater than 32 msec.
7. PS\_HOLD timer begins upon  $\overline{\text{RST}}$  going high.
8. Maximum of 500 msec period from  $\overline{\text{RST}}$  going high to PS\_HOLD going high.
9. Response time from PS\_HOLD going low to  $\overline{\text{RST}}$  going low.
10. Delay between  $\overline{\text{RST}}$  high-low transition to LDO2 disable.
11. Delay between LDO2 disable and LDO1 disable.

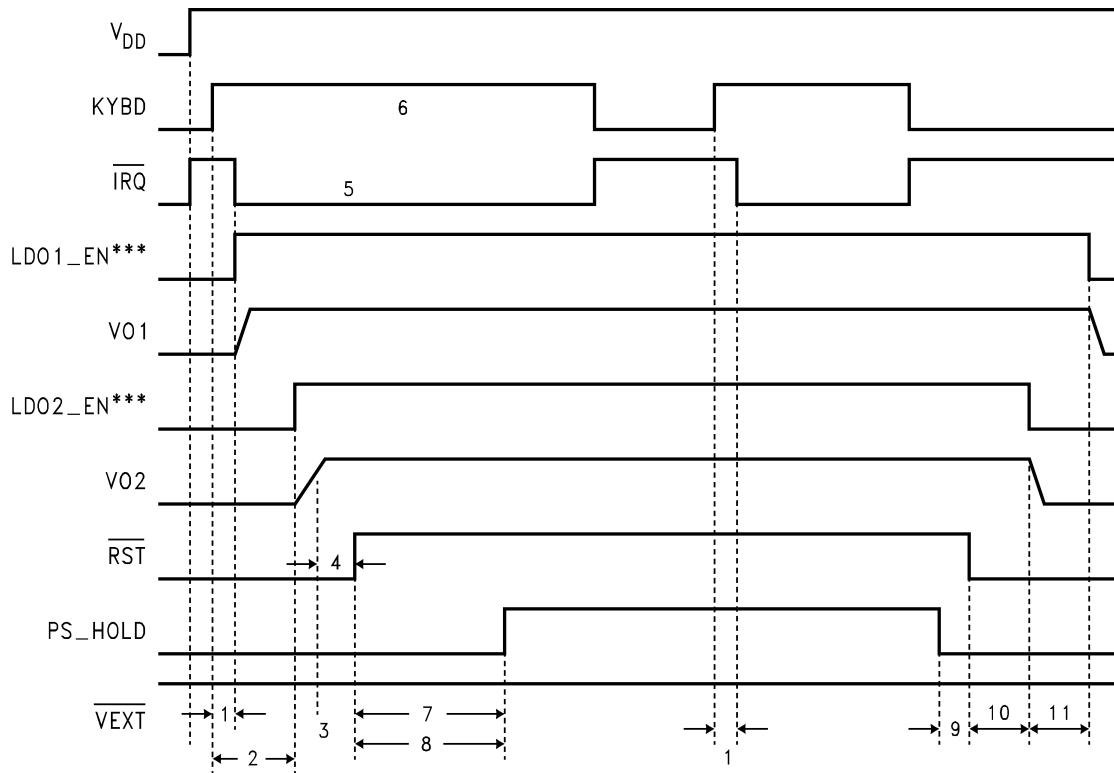

**Note:** Diagram indicates Open Drain  $\overline{\text{IRQ}}$  tied to V<sub>DD</sub>.  
 \*\*\* = Internal signal

**Figure 14. Keyboard Held at Start-Up/Shut-Down**

1. Keyboard de-bounce delay, 32msec typ.
2. Delay between LDO1 reaching 95% of its output voltage and LDO2 enable.
3. Both LDO1 and LDO2 outputs reach 95% of the respective output voltage, start  $\overline{\text{RST}}$  timer.
4. Reset delay.
5.  $\overline{\text{IRQ}}$  is active low.
6. Keyboard press must be greater than 32 msec.
7. PS\_HOLD timer begins upon  $\overline{\text{RST}}$  going high.
8. Maximum of 500 msec period from  $\overline{\text{RST}}$  going high to PS\_HOLD going high.
9. Response time from PS\_HOLD going low to  $\overline{\text{RST}}$  going low.
10. Delay between  $\overline{\text{RST}}$  high-low transition to LDO2 disable.
11. Delay between LDO2 disable and LDO1 disable.

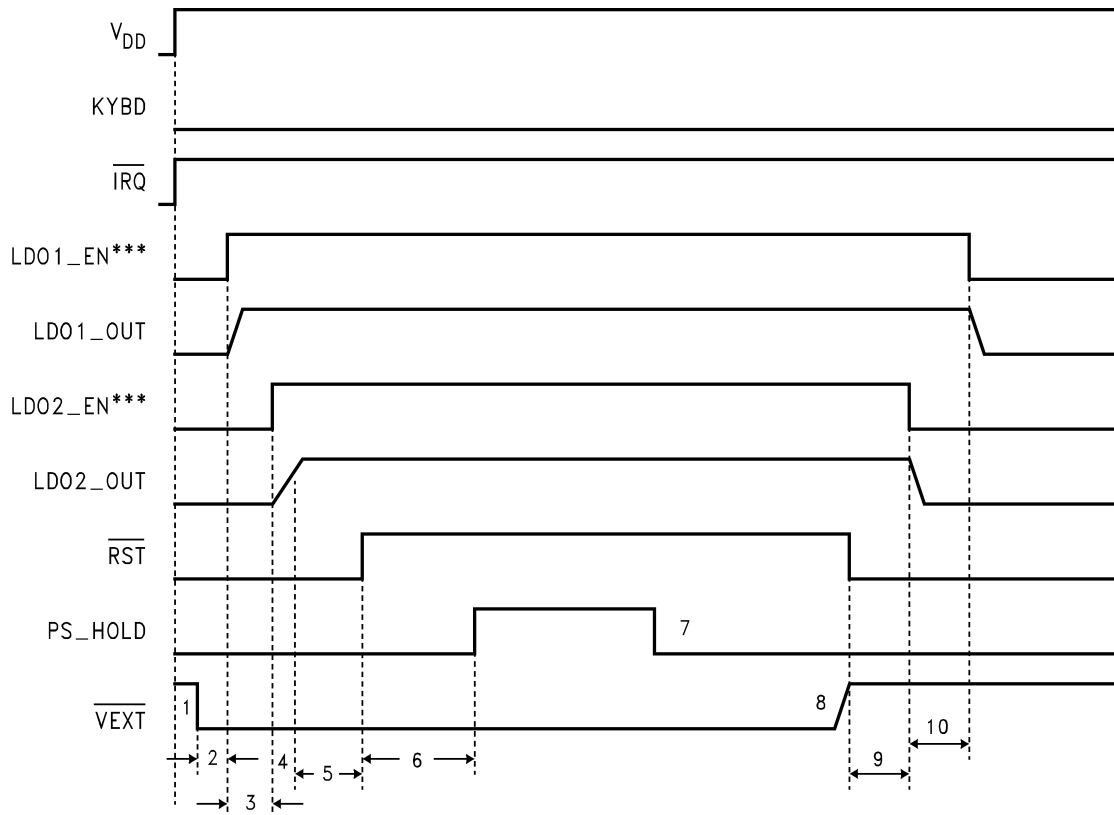

**Note:** Diagram indicates Open Drain  $\overline{\text{IRQ}}$  tied to  $V_{\text{DD}}$ .  
\*\*\* = Internal signal

**Figure 15. VEXT Detect Start-Up/Shut Down**

1.  $\overline{\text{VEXT}}$  goes active low.
2.  $\overline{\text{VEXT}}$  32 msec de-bounce period.
3. Delay between LDO1 and LDO2 enables.
4. Both LDO1 and LDO2 outputs reach 95% of respective output voltage, start Reset timer.
5. Reset delay.
6. Period between Reset and PS\_HOLD going high is not relevant since  $\overline{\text{VEXT}}$  is low
7. PS\_HOLD goes low but LDOs continue to run since  $\overline{\text{VEXT}}$  is low.
8. PS\_HOLD is low and  $\overline{\text{VEXT}}$  goes high,  $\overline{\text{RST}}$  pin goes low.
9. Delay between  $\overline{\text{RST}}$  going low and LDO2 disabled.
10. Delay between LDO2 and LDO1 disabled.

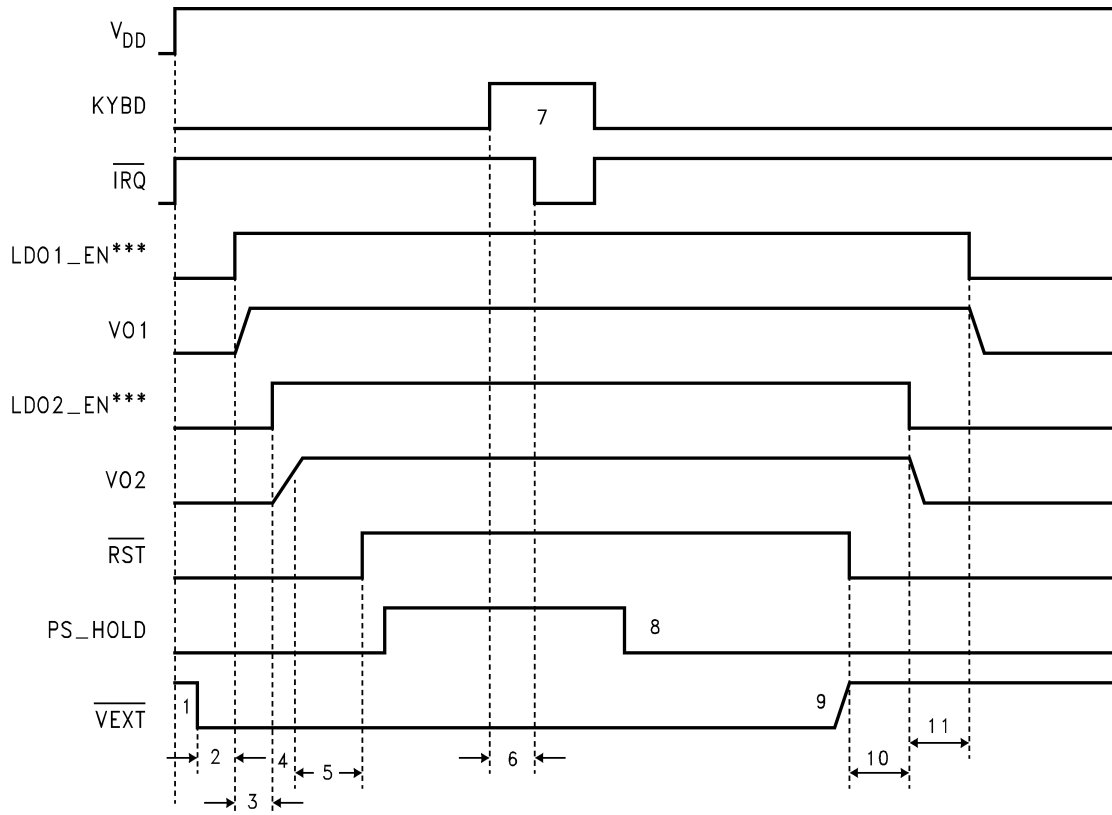

**Note:** Diagram indicates Open Drain  $\overline{\text{IRQ}}$  tied to  $V_{\text{DD}}$ .  
 \*\*\* = Internal signal

**Figure 16. VEXT Detect with Keyboard Interrupts**

1.  $\overline{\text{VEXT}}$  goes active low.
2.  $\overline{\text{VEXT}}$  32 msec de-bounce period.
3. Delay between LDO1 and LDO2 enable.
4. Both LDO1 and LDO2 outputs reach 95% of respective output voltage, start Reset timer.
5. Reset delay.
6. Keyboard de-bounce delay.
7. Keyboard pulse must be a minimum of 32 msec.
8.  $\text{PS\_HOLD}$  may go low after Key press, but LDOs stay on since  $\overline{\text{VEXT}}$  is low.
9.  $\overline{\text{VEXT}}$  goes high, begin shutdown since  $\text{PS\_HOLD}$  is low.
10. Delay between  $\overline{\text{RST}}$  going low and LDO2 disabled.
11. Delay between LDO2 disable and LDO1 disabled.

## APPLICATION HINTS

### LP3927 FUNCTION DESCRIPTION

The LP3927 is designed for cellular/PCS handsets. The LDOs power the microprocessor, RF and digital sections of the phone. When a KYBD debounce of longer than 32 ms is detected by the LP3927, the  $\overline{\text{IRQ}}$  signal is asserted and sent to the microprocessor. In addition, the KYBD signal turns on LDO1. When LDO1 reaches 95% of its output voltage option, a 125  $\mu\text{s}$  delay (standard LDO delay. The optional LDO delay has a 10msec delay) takes place, and LDO2 turns on. When LDO2 reaches 95% of its output voltage option,  $\overline{\text{RST}}$  goes high after a 20 ms delay. At this point, the microprocessor comes out of reset and the LP3927 starts the PS\_HOLD timer. If PS\_HOLD goes high before 500 ms,  $\overline{\text{IRQ}}$  is de-asserted. If PS\_HOLD stays low for longer than 500 ms,  $\overline{\text{IRQ}}$  will still de-assert, but  $\overline{\text{RST}}$  will also be asserted, and the part will power down.

The power down sequence is the exact reverse of the power up sequence. PS\_HOLD from the microprocessor goes low, indicating a request to turn the part off. This causes  $\overline{\text{RST}}$  to go low. LDO2 will be turned off after a 20 ms delay. When LDO2 drops to 90% of its output voltage option, LDO1 will start to turn off after a 125  $\mu\text{s}$  (or a 10msec) delay. Another KYBD debounce after power up does not necessary mean power down.

Whenever LDO1 or LDO2 falls under 90% of the output voltage option,  $\overline{\text{RST}}$  immediately goes low to bring PS\_HOLD low in order to turn the part off.

Plugging the charger into the cell phone will cause an external signal  $\overline{\text{VEXT}}$  to toggle from high to low. The LP3927 will respond differently to this signal depending on the scenario:

Case 1: If a charger is plugged into the cell phone after the phone is already on, the  $\overline{\text{VEXT}}$  signal go from high to low. The LP3927 will acknowledge this signal but all other signals remain unchanged.

Case 2: If a charger is plugged into the phone while the phone is off,  $\overline{\text{VEXT}}$  signal goes from high to low and the LP3927 will proceed to turn LDO1 on after a 32 ms delay, and the identical power-up sequence follows. This case bypasses the power-up initiated by KYBD and  $\overline{\text{IRQ}}$ . KYBD remains low and  $\overline{\text{IRQ}}$  remains high at all time during power-up.

When the charger is plugged in, the phone cannot be turned off unless both  $\overline{\text{VEXT}}$  goes high and PS\_HOLD goes low.

### LDOs

The LP3927 contains five LDOs. LDO1 and 2 are powered by the  $V_{\text{DD1}}$  line; LDO3 and 4 are powered by the  $V_{\text{DD2}}$  line; and LDO5 is powered by the  $V_{\text{DD3}}$  line.  $V_{\text{DD1}}$ ,  $V_{\text{DD2}}$  and  $V_{\text{DD3}}$  must be tied together externally. All five LDOs accept an input voltage from 3.0V to 5.5V. This accommodates the full usable range of a single Li-On battery.

LDO1 and 4 each provide 150 mA of current. LDO2 and 5 each provide 200 mA of current. LDO3 provides 100 mA of current. The output of each LDO can be programmed to different voltage levels at the factory. Refer to [Output Current Rating and Voltage Options](#) for more details.

### LDO INPUT CAPACITOR

An input capacitance of  $\approx 2.2 \mu\text{F}$  is required between each  $V_{\text{DD}}$  input pins and ground. (The amount of the capacitance may be increased without limit).

This capacitor must be located a distance of not more than 1 cm from the input pin and returned to a clean analog ground. Any good quality ceramic, tantalum, or film capacitor may be used at the inputs.

**Important:** Tantalum capacitors can suffer catastrophic failures due to surge current when connected to a low-impedance source of power (like a battery or a very large capacitor). If a tantalum capacitor is used at the input, it must be guaranteed by the manufacturer to have a surge current rating sufficient for the application.

There are no requirements for the ESR on the input capacitor, but tolerance and temperature coefficient must be considered when selecting the capacitor to ensure the capacitance will be  $\approx 1 \mu\text{F}$  over the entire operating temperature range.

## LDO OUTPUT CAPACITOR

The LDOs are designed specifically to work with very small ceramic output capacitors. A ceramic capacitor (X7R, X5R, Z5U, or Y5V) in 1  $\mu\text{F}$  to 20  $\mu\text{F}$  range with 5 m $\Omega$  to 500 m $\Omega$  ESR range is suitable in the LP3927 application circuit.

It may also be possible to use tantalum or film capacitors at the output, but these are not as attractive for reasons of size and cost.

The output capacitor must meet the requirement for minimum amount of capacitance and also have an ESR (Equivalent Series Resistance) value which is within a stable range (5 m $\Omega$  to 500 m $\Omega$ ).

## LED CURRENT DRIVER

The LED pin on the LP3927 is an open-drain output that can provide up to 150 mA to drive backlight LEDs. It is turned on when the LED\_EN pin is pulled high, and off when the LED\_EN pin is pulled low. The external resistor R<sub>PGM</sub> connected to the LED\_PGM pin programs the output current of LED. A 130 k $\Omega$  resistor sets the output current to 150 mA. An **approximated** equation between R<sub>PGM</sub> and I<sub>LED</sub> is:

$$I_{LED} = \frac{19235}{R_{PGM}} \quad (1)$$

## OPERATIONAL AMPLIFIER

The LP3927 has an internal op amp with rail-to-rail input and output and a 600 kHz of gain-bandwidth product.

## LEADLESS LEADFRAME PACKAGE (WQFN)

The LP3927 is packaged in a 28-lead WQFN package for enhanced thermal performance. The 28-lead WQFN measures 5 mm  $\times$  5 mm  $\times$  0.75 mm. Its small size and low profile is ideal for handset applications and other portable applications that require power management.

## THERMAL PERFORMANCE

The WQFN package is designed for enhanced thermal performance because of the exposed die attach pad at the bottom center of the package. It brings advantage to thermal performance by creating a very direct path for thermal dissipation. Compared to the traditional leaded packages where the die attach pad is embedded inside the mold compound, the WQFN reduces a layer in the thermal path.

The thermal advantage of the WQFN package is fully realized only when the exposed die attach pad is soldered down to a thermal land on the PCB board and thermal vias are planted underneath the thermal land. Based on a WQFN thermal measurement, junction to ambient thermal resistance ( $\theta_{JA}$ ) can be improved by as much as two times if a WQFN is soldered on the board with thermal land and thermal vias than if not.

Consider the following equation:

$$P = \frac{(T_J - T_A)}{\theta_{JA}} \quad (2)$$

Where P is the power dissipated, T<sub>J</sub> is the maximum junction temperature of the die, T<sub>A</sub> is the ambient temperature, and  $\theta_{JA}$  is the thermal resistance of the package. T<sub>J</sub> is specified at 150°C.

According to the above equation, in the case where the LP3927 is dissipating 3W of power, T<sub>A</sub> is limited to 32.6°C when T<sub>J</sub> of 125°C and  $\theta_{JA}$  of 30.8°C/W are used in the equation. In order to operate at a higher ambient temperature, power dissipation has to be reduced. A curve of maximum power dissipation vs ambient temperature is provided below.



**Figure 17. Power Dissipation vs Ambient Temperature ( $\theta_{JA}=30.8^{\circ}\text{C/W}$ )**

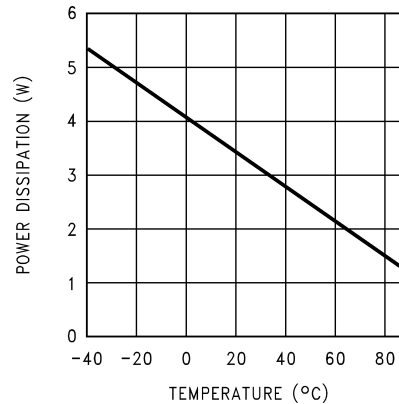

## LAYOUT CONSIDERATION

The LP3927 has an exposed die attach pad located at the bottom center of the WQFN package. It is imperative to create a thermal land on the PCB board when designing a PCB layout for the WQFN package. The thermal land helps to conduct heat away from the die, and the land should be the same dimension as the exposed pad on the bottom of the WQFN (1:1 ratio). The land should be on both the top and the bottom layer of the PCB board. In addition, thermal vias should be added inside the thermal land to conduct more heat away from the surface of the PCB to the ground plane. Typical pitch and outer diameter for these thermal vias are 1.27 mm and 0.33 mm respectively. Typical copper via barrel plating is 1 oz. although thicker copper may be used to improve thermal performance. The LP3927 bottom pad is connected to ground. Therefore, the thermal land and vias on the PCB board need to be connected to ground.

For more information on board layout techniques, refer to Application Note 1187 "Leadless Leadframe Package (LLP)." The application note also discusses package handling, solder stencil, and assembly process.

### REVISION HISTORY

Changes from Revision D (February 2013) to Revision E	Page
• Changed layout of National Data Sheet to TI format .....	<a href="#">17</a>

**PACKAGING INFORMATION**

Orderable Device	Status (1)	Package Type	Package Drawing	Pins	Package Qty	Eco Plan (2)	Lead/Ball Finish	MSL Peak Temp (3)	Op Temp (°C)	Top-Side Markings (4)	Samples
LP3927ILQ-AZ	ACTIVE	WQFN	NJB	28	1000	TBD	Call TI	Call TI	-40 to 85	3927-AZ	<a href="#">Samples</a>
LP3927ILQ-AZ/NOPB	ACTIVE	WQFN	NJB	28	1000	Green (RoHS & no Sb/Br)	CU SN	Level-3-260C-168 HR	-40 to 85	3927-AZ	<a href="#">Samples</a>
LP3927ILQX-AJ	ACTIVE	WQFN	NJB	28	4500	TBD	Call TI	Call TI	-40 to 85	3927-AJ	<a href="#">Samples</a>
LP3927ILQX-AZ	ACTIVE	WQFN	NJB	28	4500	TBD	Call TI	Call TI	-40 to 85	3927-AZ	<a href="#">Samples</a>
LP3927ILQX-AZ/NOPB	ACTIVE	WQFN	NJB	28	4500	Green (RoHS & no Sb/Br)	CU SN	Level-3-260C-168 HR	-40 to 85	3927-AZ	<a href="#">Samples</a>

(1) The marketing status values are defined as follows:

**ACTIVE:** Product device recommended for new designs.

**LIFEBUY:** TI has announced that the device will be discontinued, and a lifetime-buy period is in effect.

**NRND:** Not recommended for new designs. Device is in production to support existing customers, but TI does not recommend using this part in a new design.

**PREVIEW:** Device has been announced but is not in production. Samples may or may not be available.

**OBSOLETE:** TI has discontinued the production of the device.

(2) Eco Plan - The planned eco-friendly classification: Pb-Free (RoHS), Pb-Free (RoHS Exempt), or Green (RoHS & no Sb/Br) - please check <http://www.ti.com/productcontent> for the latest availability information and additional product content details.

**TBD:** The Pb-Free/Green conversion plan has not been defined.

**Pb-Free (RoHS):** TI's terms "Lead-Free" or "Pb-Free" mean semiconductor products that are compatible with the current RoHS requirements for all 6 substances, including the requirement that lead not exceed 0.1% by weight in homogeneous materials. Where designed to be soldered at high temperatures, TI Pb-Free products are suitable for use in specified lead-free processes.

**Pb-Free (RoHS Exempt):** This component has a RoHS exemption for either 1) lead-based flip-chip solder bumps used between the die and package, or 2) lead-based die adhesive used between the die and leadframe. The component is otherwise considered Pb-Free (RoHS compatible) as defined above.

**Green (RoHS & no Sb/Br):** TI defines "Green" to mean Pb-Free (RoHS compatible), and free of Bromine (Br) and Antimony (Sb) based flame retardants (Br or Sb do not exceed 0.1% by weight in homogeneous material)

(3) MSL, Peak Temp. -- The Moisture Sensitivity Level rating according to the JEDEC industry standard classifications, and peak solder temperature.

(4) Multiple Top-Side Markings will be inside parentheses. Only one Top-Side Marking contained in parentheses and separated by a "~" will appear on a device. If a line is indented then it is a continuation of the previous line and the two combined represent the entire Top-Side Marking for that device.

**Important Information and Disclaimer:** The information provided on this page represents TI's knowledge and belief as of the date that it is provided. TI bases its knowledge and belief on information provided by third parties, and makes no representation or warranty as to the accuracy of such information. Efforts are underway to better integrate information from third parties. TI has taken and continues to take reasonable steps to provide representative and accurate information but may not have conducted destructive testing or chemical analysis on incoming materials and chemicals. TI and TI suppliers consider certain information to be proprietary, and thus CAS numbers and other limited information may not be available for release.

In no event shall TI's liability arising out of such information exceed the total purchase price of the TI part(s) at issue in this document sold by TI to Customer on an annual basis.

**TAPE AND REEL INFORMATION**

**QUADRANT ASSIGNMENTS FOR PIN 1 ORIENTATION IN TAPE**

\*All dimensions are nominal

Device	Package Type	Package Drawing	Pins	SPQ	Reel Diameter (mm)	Reel Width W1 (mm)	A0 (mm)	B0 (mm)	K0 (mm)	P1 (mm)	W (mm)	Pin1 Quadrant
LP3927ILQ-AZ	WQFN	NJB	28	1000	178.0	12.4	5.3	5.3	1.3	8.0	12.0	Q1
LP3927ILQ-AZ/NOPB	WQFN	NJB	28	1000	178.0	12.4	5.3	5.3	1.3	8.0	12.0	Q1
LP3927ILQX-AJ	WQFN	NJB	28	4500	330.0	12.4	5.3	5.3	1.3	8.0	12.0	Q1
LP3927ILQX-AZ	WQFN	NJB	28	4500	330.0	12.4	5.3	5.3	1.3	8.0	12.0	Q1
LP3927ILQX-AZ/NOPB	WQFN	NJB	28	4500	330.0	12.4	5.3	5.3	1.3	8.0	12.0	Q1

**TAPE AND REEL BOX DIMENSIONS**



\*All dimensions are nominal

Device	Package Type	Package Drawing	Pins	SPQ	Length (mm)	Width (mm)	Height (mm)
LP3927ILQ-AZ	WQFN	NJB	28	1000	203.0	190.0	41.0
LP3927ILQ-AZ/NOPB	WQFN	NJB	28	1000	213.0	191.0	55.0
LP3927ILQX-AJ	WQFN	NJB	28	4500	367.0	367.0	35.0
LP3927ILQX-AZ	WQFN	NJB	28	4500	367.0	367.0	35.0
LP3927ILQX-AZ/NOPB	WQFN	NJB	28	4500	367.0	367.0	35.0

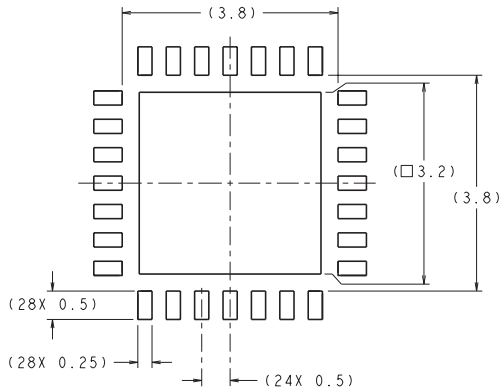
NJB0028A

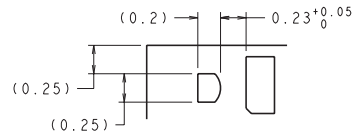

**RECOMMENDED LAND PATTERN**  
1:1 RATION WITH PKG SOLDER PADS



**DETAIL A**  
SCALE: 40X

DIMENSIONS ARE IN MILLIMETERS

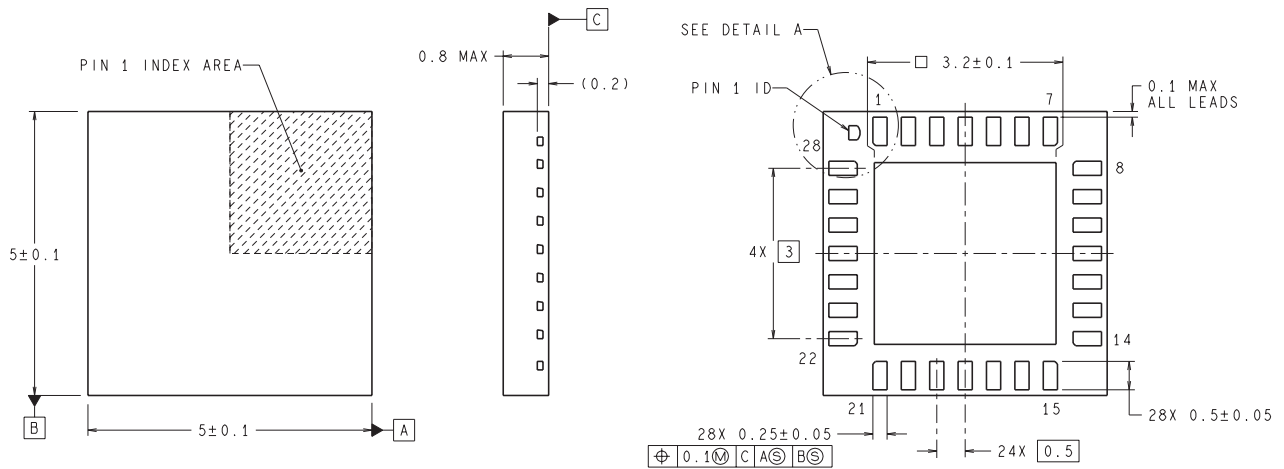

LQA28A (REV B)

## IMPORTANT NOTICE

Texas Instruments Incorporated and its subsidiaries (TI) reserve the right to make corrections, enhancements, improvements and other changes to its semiconductor products and services per JESD46, latest issue, and to discontinue any product or service per JESD48, latest issue. Buyers should obtain the latest relevant information before placing orders and should verify that such information is current and complete. All semiconductor products (also referred to herein as "components") are sold subject to TI's terms and conditions of sale supplied at the time of order acknowledgment.

TI warrants performance of its components to the specifications applicable at the time of sale, in accordance with the warranty in TI's terms and conditions of sale of semiconductor products. Testing and other quality control techniques are used to the extent TI deems necessary to support this warranty. Except where mandated by applicable law, testing of all parameters of each component is not necessarily performed.

TI assumes no liability for applications assistance or the design of Buyers' products. Buyers are responsible for their products and applications using TI components. To minimize the risks associated with Buyers' products and applications, Buyers should provide adequate design and operating safeguards.

TI does not warrant or represent that any license, either express or implied, is granted under any patent right, copyright, mask work right, or other intellectual property right relating to any combination, machine, or process in which TI components or services are used. Information published by TI regarding third-party products or services does not constitute a license to use such products or services or a warranty or endorsement thereof. Use of such information may require a license from a third party under the patents or other intellectual property of the third party, or a license from TI under the patents or other intellectual property of TI.

Reproduction of significant portions of TI information in TI data books or data sheets is permissible only if reproduction is without alteration and is accompanied by all associated warranties, conditions, limitations, and notices. TI is not responsible or liable for such altered documentation. Information of third parties may be subject to additional restrictions.

Resale of TI components or services with statements different from or beyond the parameters stated by TI for that component or service voids all express and any implied warranties for the associated TI component or service and is an unfair and deceptive business practice. TI is not responsible or liable for any such statements.

Buyer acknowledges and agrees that it is solely responsible for compliance with all legal, regulatory and safety-related requirements concerning its products, and any use of TI components in its applications, notwithstanding any applications-related information or support that may be provided by TI. Buyer represents and agrees that it has all the necessary expertise to create and implement safeguards which anticipate dangerous consequences of failures, monitor failures and their consequences, lessen the likelihood of failures that might cause harm and take appropriate remedial actions. Buyer will fully indemnify TI and its representatives against any damages arising out of the use of any TI components in safety-critical applications.

In some cases, TI components may be promoted specifically to facilitate safety-related applications. With such components, TI's goal is to help enable customers to design and create their own end-product solutions that meet applicable functional safety standards and requirements. Nonetheless, such components are subject to these terms.

No TI components are authorized for use in FDA Class III (or similar life-critical medical equipment) unless authorized officers of the parties have executed a special agreement specifically governing such use.

Only those TI components which TI has specifically designated as military grade or "enhanced plastic" are designed and intended for use in military/aerospace applications or environments. Buyer acknowledges and agrees that any military or aerospace use of TI components which have **not** been so designated is solely at the Buyer's risk, and that Buyer is solely responsible for compliance with all legal and regulatory requirements in connection with such use.

TI has specifically designated certain components as meeting ISO/TS16949 requirements, mainly for automotive use. In any case of use of non-designated products, TI will not be responsible for any failure to meet ISO/TS16949.

### Products

Audio	<a href="http://www.ti.com/audio">www.ti.com/audio</a>
Amplifiers	<a href="http://amplifier.ti.com">amplifier.ti.com</a>
Data Converters	<a href="http://dataconverter.ti.com">dataconverter.ti.com</a>
DLP® Products	<a href="http://www.dlp.com">www.dlp.com</a>
DSP	<a href="http://dsp.ti.com">dsp.ti.com</a>
Clocks and Timers	<a href="http://www.ti.com/clocks">www.ti.com/clocks</a>
Interface	<a href="http://interface.ti.com">interface.ti.com</a>
Logic	<a href="http://logic.ti.com">logic.ti.com</a>
Power Mgmt	<a href="http://power.ti.com">power.ti.com</a>
Microcontrollers	<a href="http://microcontroller.ti.com">microcontroller.ti.com</a>
RFID	<a href="http://www.ti-rfid.com">www.ti-rfid.com</a>
OMAP Applications Processors	<a href="http://www.ti.com/omap">www.ti.com/omap</a>
Wireless Connectivity	<a href="http://www.ti.com/wirelessconnectivity">www.ti.com/wirelessconnectivity</a>

### Applications

Automotive and Transportation	<a href="http://www.ti.com/automotive">www.ti.com/automotive</a>
Communications and Telecom	<a href="http://www.ti.com/communications">www.ti.com/communications</a>
Computers and Peripherals	<a href="http://www.ti.com/computers">www.ti.com/computers</a>
Consumer Electronics	<a href="http://www.ti.com/consumer-apps">www.ti.com/consumer-apps</a>
Energy and Lighting	<a href="http://www.ti.com/energy">www.ti.com/energy</a>
Industrial	<a href="http://www.ti.com/industrial">www.ti.com/industrial</a>
Medical	<a href="http://www.ti.com/medical">www.ti.com/medical</a>
Security	<a href="http://www.ti.com/security">www.ti.com/security</a>
Space, Avionics and Defense	<a href="http://www.ti.com/space-avionics-defense">www.ti.com/space-avionics-defense</a>
Video and Imaging	<a href="http://www.ti.com/video">www.ti.com/video</a>

### TI E2E Community

[e2e.ti.com](http://e2e.ti.com)