

LP3931 Dual RGB LED Driver with High Current Boost DC-DC Converter

Check for Samples: [LP3931](#)

FEATURES

- High Efficiency Programmable 300 mA Magnetic Boost DC-DC Converter
- 2 Separately Controlled PWM RGB LED Drivers With Programmable Color, Brightness, Turn On/Off Slopes and Blinking Patterns
- FLASH Function With up to 6 Outputs, Each up to 120 mA
- Functions Software Controlled Through SPI Interface
- Additional LED On/Off and Dimming Hardware Control
- Programmable Low Current Standby Mode
- Low Voltage Digital Interface Down to 1.8V
- Space Efficient 24-Pin LLP Package

DESCRIPTION

The LP3931 is a RGB LED driver with high current boost DC-DC converter designed for portable wireless applications. It contains 2 sets of RGB LED drivers that are PWM-driven with programmable color, intensity and blinking patterns. They additionally feature a FLASH function to support picture taking with camera-enabled cellular phones.

An efficient magnetic boost DC/DC converter provides the required bias, operating from a single Li-Ion battery. The DC/DC converter output voltage is user programmable for adapting to different LED types and for efficiency optimization.

All functions are software controllable through the SPI interface and internal registers.

APPLICATIONS

- GSM Cellular Phones
- WCDMA, CDMA and CDMA2000 Phones
- PHS and PDC Cellular Phone

Typical Application

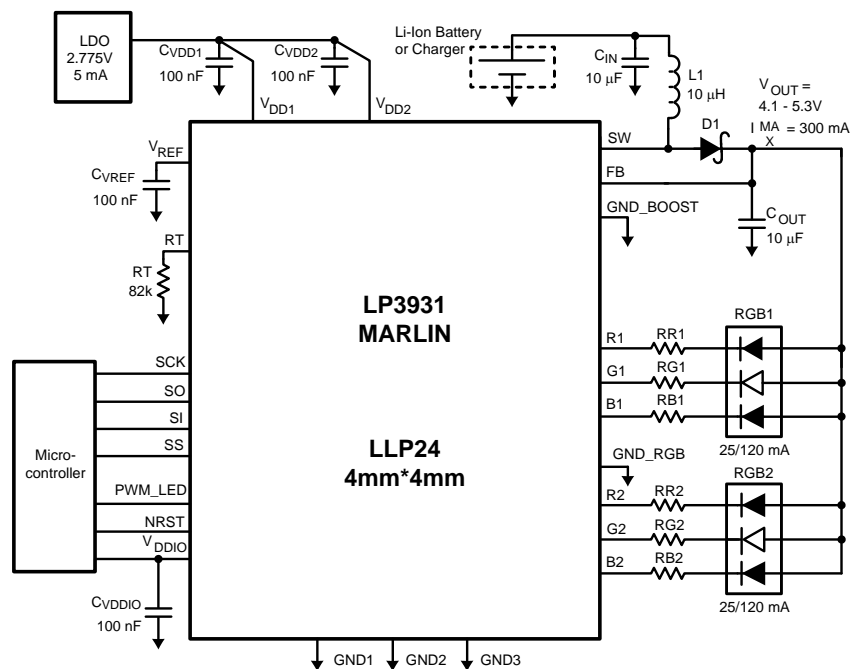

Please be aware that an important notice concerning availability, standard warranty, and use in critical applications of Texas Instruments semiconductor products and disclaimers thereto appears at the end of this data sheet.

All trademarks are the property of their respective owners.

Connection Diagrams

24-Lead LLP Package, 4 x 4 x 0.8 mm: Package Number NSQAL024

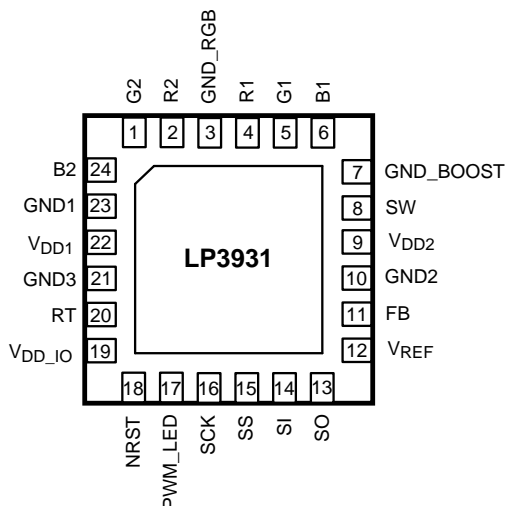

Figure 1. Bottom View

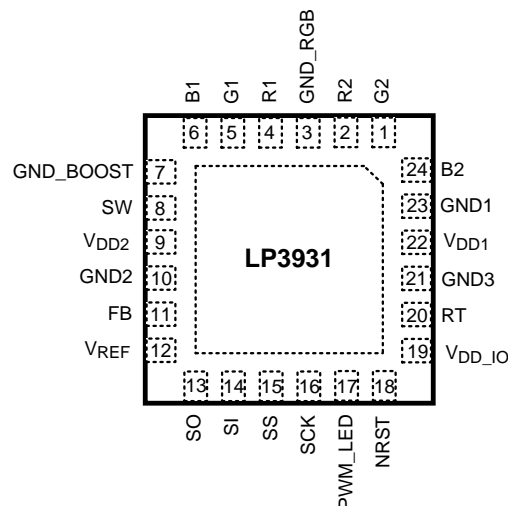

Figure 2. Top View

Pin Descriptions

Pin #	Name	Type	Description
1	G2	Output	Open Drain, Green LED2
2	R2	Output	Open Drain, Red LED2
3	GND_RGB	Ground	RGB Driver Ground
4	R1	Output	Open Drain, Red LED1
5	G1	Output	Open Drain, Green LED1
6	B1	Output	Open Drain, Blue LED1
7	GND_BOOST	Ground	Power Switch Ground
8	SW	Output	Open Drain, Boost Converter Power Switch
9	V _{DD2}	Power	Supply Voltage for Internal Digital Circuits
10	GND2	Ground	Ground
11	FB	Input	Boost Converter Feedback
12	V _{REF}	Output	Internal Reference Bypass Capacitor
13	SO	Logic Output	SPI Serial Data Out
14	SI	Logic Input	SPI Serial Data Input
15	SS	Logic Input	SPI Slave Select
16	SCK	Logic Input	SPI Clock
17	PWM_LED	Input	LED Control for On/Off or PWM Dimming
18	NRST	Logic Input	Low Active Reset Input
19	V _{DDIO}	Power	Supply Voltage for Logic IO Signals
20	RT	Input	Oscillator Resistor
21	GND3	Ground	Ground
22	V _{DD1}	Power	Supply Voltage for Internal Analog Circuits
23	GND1	Ground	Ground
24	B2	Output	Open Drain, Blue LED2



These devices have limited built-in ESD protection. The leads should be shorted together or the device placed in conductive foam during storage or handling to prevent electrostatic damage to the MOS gates.

Absolute Maximum Ratings^{(1) (2)(3)}

V (SW, FB, R1- 2, G1-2, B1-2) pins: Voltage to GND ^{(4) (5)}		-0.3V to +7.2V
V _{DD1} , V _{DD2} , V _{DD_IO}		-0.3V to +6.0V
Voltage on Logic Pins		-0.3V to V _{DD_IO} +0.3V, with 6.0V max
I (R1, G1, B1, R2, G2, B2) ⁽⁶⁾		150 mA
I (V _{REF})		10 μA
Continuous Power Dissipation ⁽⁷⁾		Internally Limited
Junction Temperature (T _{J-MAX})		125°C
Storage Temperature Range		-65°C to +150°C
Maximum Lead Temperature (Reflow soldering, 3 times) ⁽⁸⁾		240°C
ESD Rating ⁽⁹⁾	Human Body Model	2 kV
	Machine Model	200V

- (1) All voltages are with respect to the potential at the GND pins (GND1-3, GND_BOOST, GND_RGB).
- (2) Absolute Maximum Ratings indicate limits beyond which damage to the component may occur. Operating Ratings are conditions under which operation of the device is specified. Operating Ratings do not imply ensured performance limits. For ensured performance limits and associated test conditions, see the Electrical Characteristics tables.
- (3) If Military/Aerospace specified devices are required, please contact the Texas Instruments Sales Office/Distributors for availability and specifications.
- (4) Battery/Charger voltage should be above 6V no more than 10% of the operational lifetime.
- (5) Voltage tolerance of LP3931 above 6.0V relies on fact that V_{DD1} and V_{DD2} (2.775V) are available (ON) at all conditions. If V_{DD1} and V_{DD2} are not available (ON) at all conditions, Texas Instruments does not ensure any parameters or reliability for this device.
- (6) The total load current of the boost converter should be limited to 300 mA.
- (7) Internal thermal shutdown circuitry protects the device from permanent damage. Thermal shutdown engages at T_J = 160°C (typ.) and disengages at T_J = 140°C (typ.).
- (8) For detailed package and soldering specifications and information, please refer to Application Note 1187: Leadless Leadframe Package (LLP) (literature number [SNOA401](#)).
- (9) The Human body model is a 100 pF capacitor discharged through a 1.5 kΩ resistor into each pin. The machine model is a 200 pF capacitor discharged directly into each pin. MIL-STD-883 3015.7.

Operating Ratings^{(1) (2)}

V (SW, FB, R1-2, G1-2, B1-2)		3.0V to 6.0V
V _{DD1} , V _{DD2} ⁽³⁾		2.65V to 2.9V
V _{DD_IO}		1.8V to V _{DD1,2}
Recommended Load Current		0 mA to 300 mA
Junction Temperature (T _J) Range		-40°C to +125°C
Ambient Temperature (T _A) Range ⁽⁴⁾		-40°C to +85°C

- (1) Absolute Maximum Ratings indicate limits beyond which damage to the component may occur. Operating Ratings are conditions under which operation of the device is specified. Operating Ratings do not imply ensured performance limits. For ensured performance limits and associated test conditions, see the Electrical Characteristics tables.
- (2) All voltages are with respect to the potential at the GND pins (GND1-3, GND_BOOST, GND_RGB).
- (3) Voltage tolerance of LP3931 above 6.0V relies on fact that V_{DD1} and V_{DD2} (2.775V) are available (ON) at all conditions. If V_{DD1} and V_{DD2} are not available (ON) at all conditions, Texas Instruments does not ensure any parameters or reliability for this device.
- (4) In applications where high power dissipation and/or poor package thermal resistance is present, the maximum ambient temperature may have to be derated. Maximum ambient temperature (T_{A-MAX}) is dependent on the maximum operating junction temperature (T_{J-MAX-OP} = 125°C), the maximum power dissipation of the device in the application (P_{D-MAX}), and the junction-to ambient thermal resistance of the part/package in the application (θ_{JA}), as given by the following equation: T_{A-MAX} = T_{J-MAX-OP} - (θ_{JA} × P_{D-MAX}).

Thermal Properties

Junction-to-Ambient Thermal Resistance (θ _{JA}), SQA24A Package ⁽¹⁾		39°C/W
--	--	--------

- (1) Junction-to-ambient thermal resistance is highly application and board-layout dependent. In applications where high maximum power dissipation exists, special care must be paid to thermal dissipation issues in board design.

Electrical Characteristics^{(1) (2)}

Limits in standard typeface are for $T_J = 25^\circ\text{C}$. Limits in **boldface** type apply over the operating ambient temperature range ($-40^\circ\text{C} \leq T_J \leq +85^\circ\text{C}$). Unless otherwise noted, specifications apply to the LP3931 Typical Application Circuit (pg. 1) with: $V_{DD1} = V_{DD2} = V_{DDIO} = 2.775\text{V}$, $C_{VDD1} = C_{VDD2} = C_{VDDIO} = 0.1 \mu\text{F}$, $C_{OUT} = C_{IN} = 10 \mu\text{F}$, $C_{VREF} = 0.1 \mu\text{F}$, $L_1 = 10 \mu\text{H}$, $R_T = 82\text{k}$ ⁽³⁾.

Symbol	Parameter	Condition	Min	Typ	Max	Units
I_{DD}	Standby Supply Current (V_{DD1} and V_{DD2} current)	NSTBY = L (register) SCK, SS, SI, NRST = H		1	5	μA
	No-Load Supply Current (V_{DD1} and V_{DD2} current, boost off)	NSTBY = H (reg.) EN_BOOST = L (reg.) SCK, SS, SI, NRST = H		170	250	μA
	Full Load Supply Current (V_{DD1} and V_{DD2} current, boost on)	NSTBY = H (reg.) EN_BOOST = H (reg.) SCK, SS, SI, NRST = H All Outputs Active		1		mA
I_{DD_IO}	V_{DD_IO} Standby Supply Current	NSTBY = L (reg.) SCK, SS, SI, NRST = H		1		μA
	V_{DD_IO} Supply Current	1 MHz SCK Frequency $C_L = 50 \text{ pF}$ at SO Pin		20		μA
V_{REF}	Reference Voltage ⁽⁴⁾	$I(V_{REF}) \leq 1 \text{ nA}$, Test Purposes Only	1.205 -2	1.23	1.255 +2	V %

- (1) All voltages are with respect to the potential at the GND pins (GND1-3, GND_BOOST, GND_RGB).
- (2) Min and Max limits are specified by design, test, or statistical analysis. Typical numbers are not ensured, but do represent the most likely norm.
- (3) Low-ESR Surface-Mount Ceramic Capacitors (MLCCs) are used in setting electrical characteristics.
- (4) V_{REF} pin (Bandgap reference output) is for internal use only. A capacitor should always be placed between V_{REF} and GND1.

BLOCK DIAGRAM

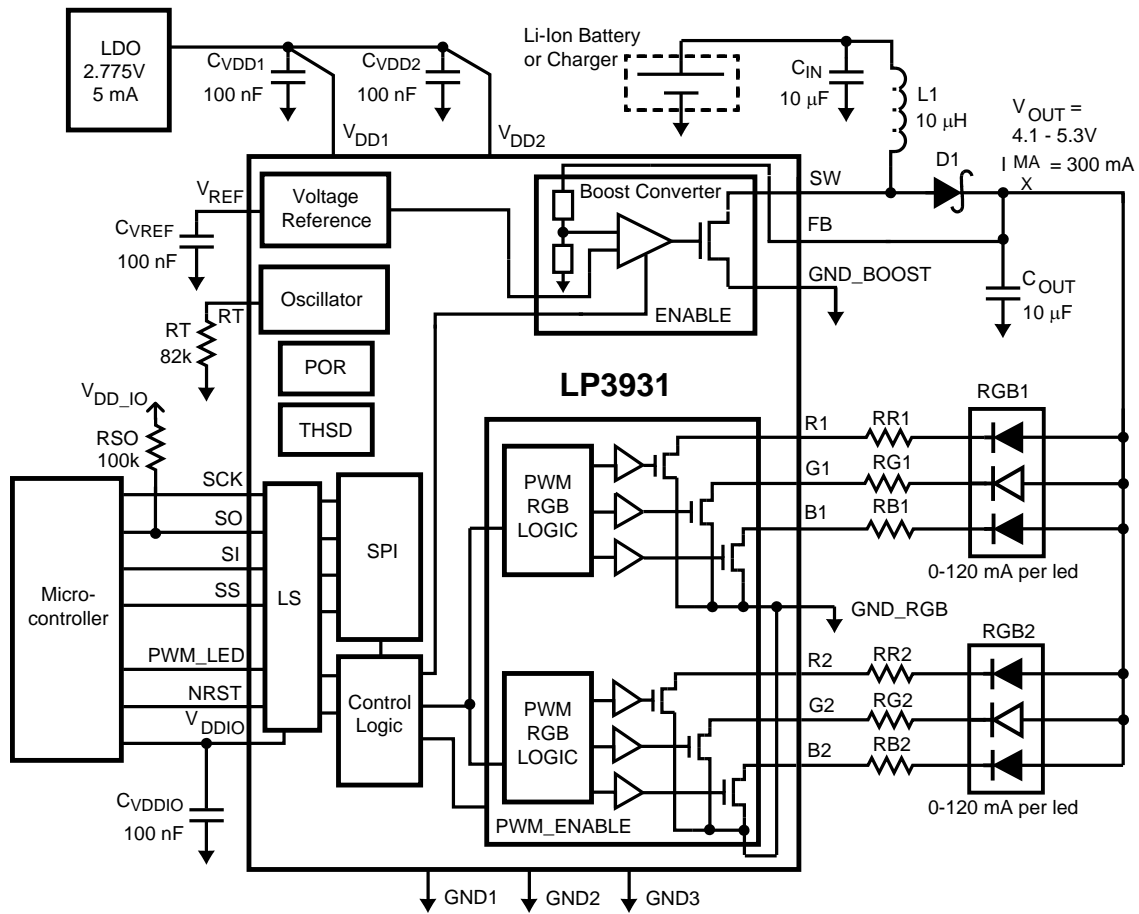
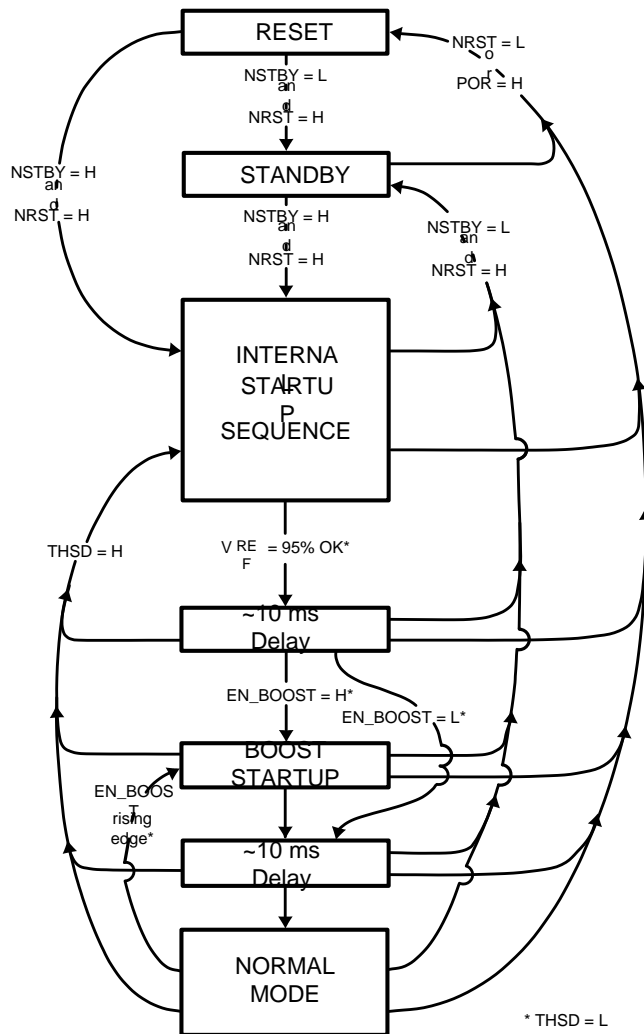

Figure 3. LP3931 Block Diagram

MODES OF OPERATION

- RESET:** In the RESET mode all the internal registers are reset to the default values (Boost output register 3Fh (5.0V), all other registers 00h). Reset is entered always if input NRST is LOW or internal Power On Reset is active.
- STANDBY:** The STANDBY mode is entered if the register bit NSTBY is LOW and Reset is not active. This is the low power consumption mode, when all circuit functions are disabled. Registers can be written in this mode and the control bits are effective immediately after power up.
- STARTUP:** INTERNAL STARTUP SEQUENCE powers up all the needed internal blocks (V_{REF} , Bias, Oscillator etc.). To ensure the correct oscillator initialization, a 10 ms delay is generated by the internal state-machine. Thermal shutdown (THSD) disables the chip operation and Startup mode is entered until *no* thermal shutdown event is present.
- BOOST STARTUP:** Soft start for boost output is generated in the BOOST STARTUP mode. In this mode the boost output is raised in PFM mode during the 10 ms delay generated by the state-machine. The Boost startup is entered from Internal Startup Sequence if EN_BOOST is HIGH or from Normal mode when EN_BOOST is written HIGH.
- NORMAL:** During NORMAL mode the user controls the chip using the *Control Registers*. The registers can be written in any sequence and any number of bits can be altered in a register in one write.



Logic Interface Characteristics⁽⁵⁾

Symbol	Parameter	Conditions	Min	Typ	Max	Units
LOGIC INPUTS SS, SI, SCK, PWM_LED						
V _{IL}	Input Low Level				0.5	V
V _{IH}	Input High Level		V _{DD_IO} - 0.5			V
I _I	Logic Input Current		-1.0		1.0	μA
f _{SCK}	Clock Frequency	V _{DD_IO} = 2.775V			13	MHz
LOGIC INPUT NRST						
V _{IL}	Input Low Level				0.5	V
V _{IH}	Input High Level		1.5			V
I _I	Logic Input Current		-1.0		1.0	μA
t _{NRST}	Reset Pulse Width		10			μs
LOGIC OUTPUT SO						
V _{OL}	Output Low Level	I _{SO} = 3 mA		0.3	0.5	V
V _{OH}	Output High Level	I _{SO} = - 3 mA	V _{DD_IO} - 0.5	V _{DD_IO} - 0.3		V

(5) (1.8V ≤ V_{DD_IO} ≤ V_{DD1,2})

SPI Interface

LP3931 is compatible with the SPI serial bus specification and it operates as a slave. The transmission consists of 16-bit Write and Read Cycles. One cycle consists of 7 Address bits, 1 Read/Write (R/W) bit and 8 Data bits. R/W bit high state defines a Write Cycle and low defines a Read Cycle. SO output is normally in high-impedance state and it is active only when Data is sent out during a Read Cycle. A pull-up or pull-down resistor may be needed in SO line if a floating logic signal can cause unintended current consumption in the input where SO is connected. The Address and Data are transmitted MSB first. The Slave Select signal SS must be low during the Cycle transmission. SS resets the interface when high and it has to be taken high between successive Cycles. Data is clocked in on the rising edge of the SCK clock signal, while data is clocked out on the falling edge of SCK.

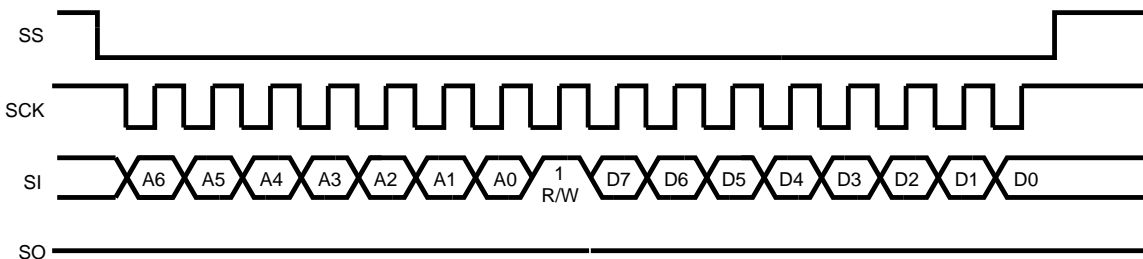

Figure 4. SPI Write Cycle

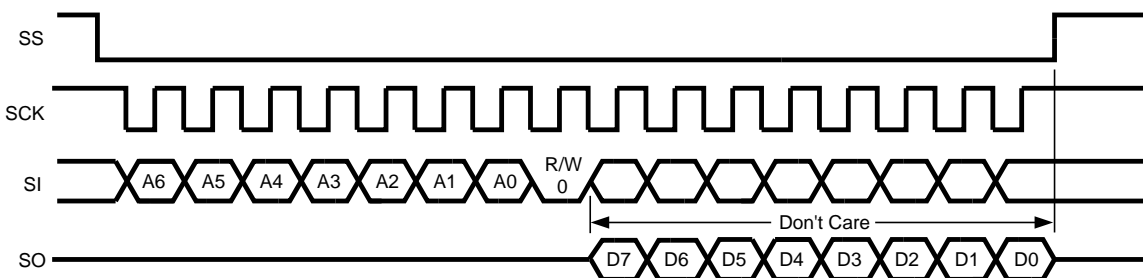

Figure 5. SPI Read Cycle

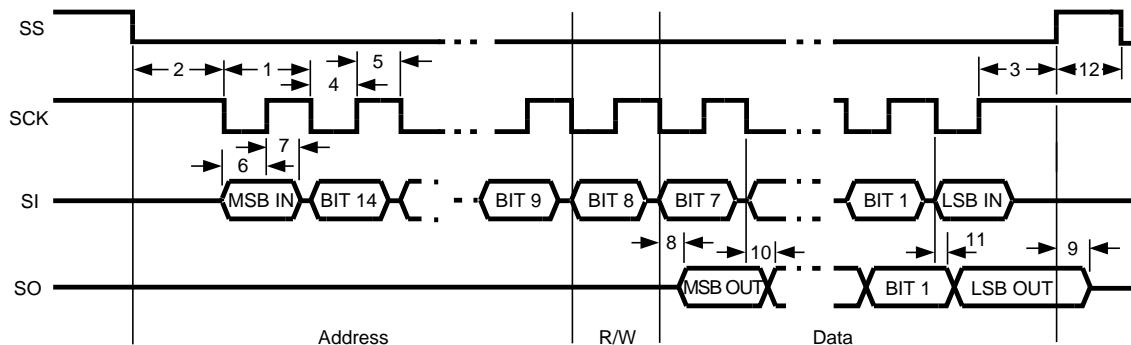

Figure 6. SPI Timing Diagram

SPI Timing Parameters⁽¹⁾

Symbol	Parameter	Limit ⁽²⁾		Units
		Min	Max	
1	Cycle Time	70		ns
2	Enable Lead Time	35		ns
3	Enable Lag Time	35		ns
4	Clock High Time	35		ns
5	Clock Low Time	35		ns
6	Data Setup Time	0		ns
7	Data Hold Time	20		ns
8	Data Access Time	0	20	ns
9	Disable Time		10	ns
10	Data Valid		20	ns
11	Data Hold Time	0		ns
12	SS Inactive Time	10		ns

(1) $V_{DD1,2} = V_{DD_IO} = 2.775V$

(2) Data specified by simulation.

Magnetic Boost DC/DC Converter

The LP3931 Boost DC/DC Converter generates a 4.1V–5.3V supply voltage for the LEDs from single Li-Ion battery (3V...4.5V). The output voltage is controlled with an 8-bit register in 9 steps. The converter is a magnetic switching PWM mode DC/DC converter with a current limit. The converter switching frequency is 1 MHz when timing resistor R_T is 82 k Ω .

The topology of the magnetic boost converter is called CPM control, current programmed mode, where the inductor current is measured and controlled with the feedback. The user can program the output voltage of the boost converter. The control changes the resistor divider in the feedback loop.

The following figure shows the boost topology with the protection circuitry. Three different protection schemes are implemented:

1. Over voltage protection, limits the maximum output voltage
 - Keeps the output below breakdown voltage.
 - Prevents boost operation if battery voltage is much higher than desired output.
2. Over current protection, limits the maximum inductor current
 - Voltage over switching NMOS is monitored; too high voltages turn the switch off.
3. Duty cycle limiting, done with digital control.

Figure 7. Boost Converter Topology

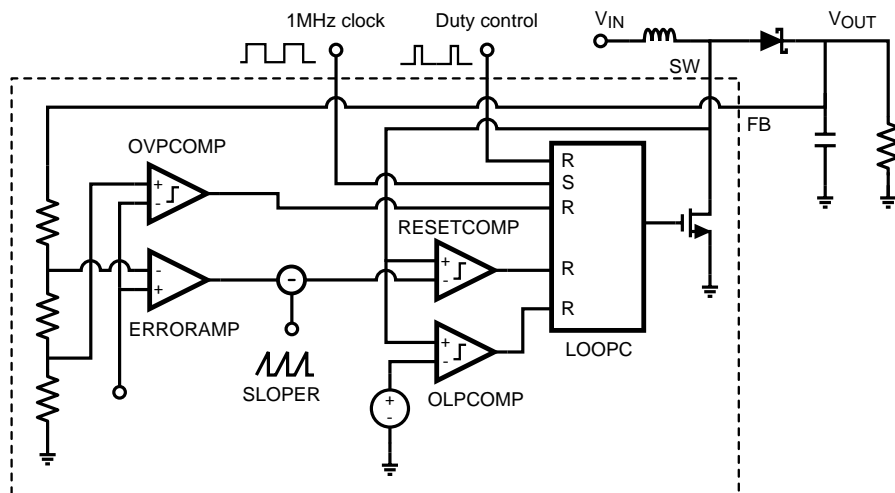

Magnetic Boost DC/DC Converter Electrical Characteristics

Symbol	Parameter	Conditions	Min	Typ	Max	Units
I_{LOAD}	Load Current	$3.0V \leq V_{IN} \leq 4.5V$ $V_{OUT} (FB) = 5V$	0		300	mA
V_{FB}	Voltage Accuracy at FB Pin (Boost Converter Output Voltage Accuracy)	$1 mA \leq I_{SW} \leq 300 mA$ $3.0V \leq V_{IN} \leq V (FB) - 0.5$ $V (FB) = 5V$	-5		+5	%
	Voltage at FB Pin (Boost Converter Output Voltage)	$1 mA \leq I_{SW} \leq 300 mA$ $3.0V < V_{IN} < 5V + V_{(SCHOTTKY)}$		5		V
		$1 mA \leq I_{SW} \leq 300 mA$ $V_{IN} > 5V + V_{(SCHOTTKY)}$		$V_{IN} - V_{(SCHOTTKY)}$		V
$R_{DS(ON)}$	Switch ON Resistance	$V_{DD1,2} = 2.775V, I_{SW} = 0.5A$		0.4	0.7	Ω
f_{PWF}	PWM Mode Switching Frequency	$R_T = 82 k\Omega$		1		MHz
	Frequency Accuracy	$2.65 \leq V_{DD1,2} \leq 2.9$ $R_T = 82 k\Omega$	-6 -9	± 3	+6 +9	%
$t_{STARTUP}$	Startup Time	From NSTBY and EN_BOOST 0 -> 1 transition		25		ms
I_{CL_OUT}	SW Pin Current Limit		670	800	915	mA
			530		995	

Boost Standby Mode

User can set the Boost Converter to STANDBY mode by writing the register bit EN_BOOST low. When EN_BOOST is written high, the converter waits for 10 ms for the internal voltages and currents to stabilize and then starts for 10 ms in PFM mode and then goes to PWM mode.

Boost Output Voltage Control

User can control the boost output voltage by 8-bit boost output register as follows:

Register 0DH Boost Output [7:0]	BOOST Output Voltage (typical)
0000 0000	4.15
0000 0001	4.30
0000 0011	4.40
0000 0111	4.55
0000 1111	4.70
0001 1111	4.85
0011 1111	5.00 Default
0111 1111	5.15
1111 1111	5.30

Figure 8. Boost Output Voltage Control

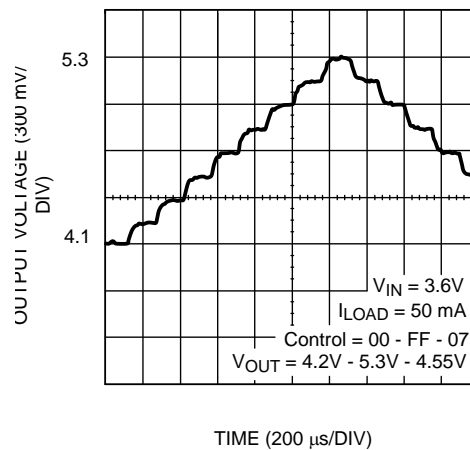

Boost Converter Typical Performance Characteristics

$V_{IN} = 3.6V$, $V_{OUT} = 5.0V$ if not otherwise stated.

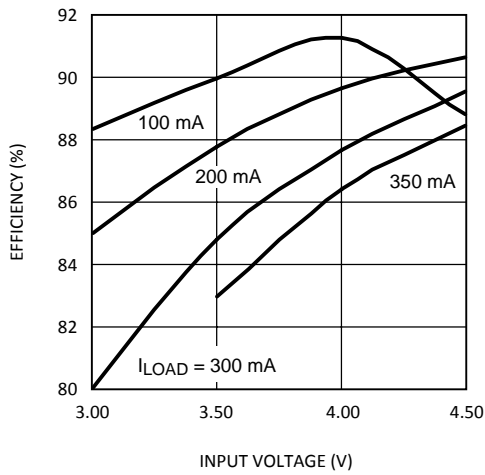

Figure 9. Boost Converter Efficiency

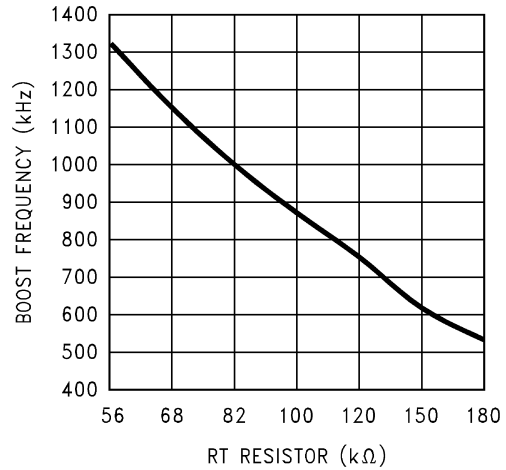

Figure 10. Boost Frequency vs RT Resistor

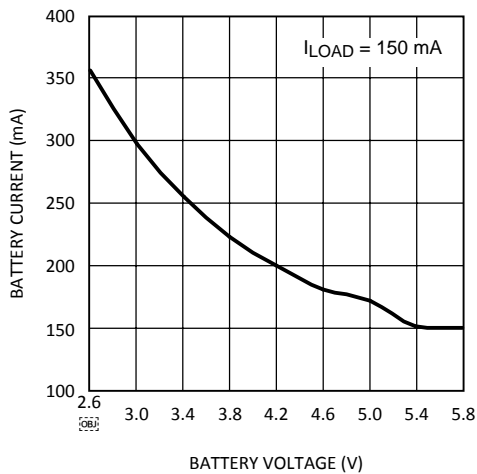

Figure 11. Battery Current vs Voltage

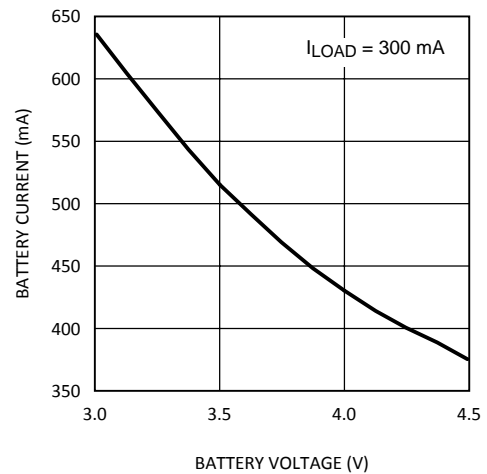

Figure 12. Battery Current vs Voltage

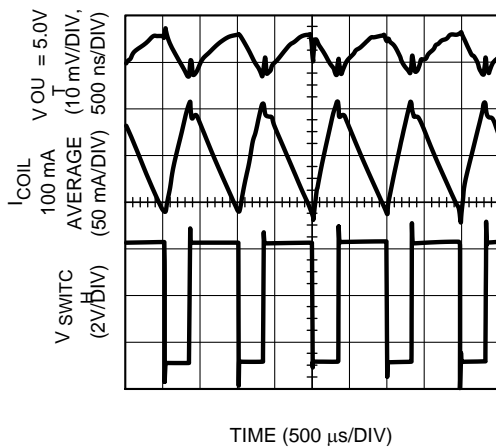

Figure 13. Boost Typical Waveforms at 100 mA Load

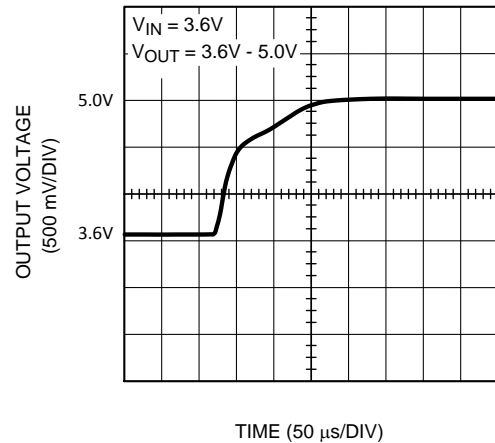

Figure 14. Boost Startup with No Load

Boost Converter Typical Performance Characteristics (continued)

$V_{IN} = 3.6V$, $V_{OUT} = 5.0V$ if not otherwise stated.

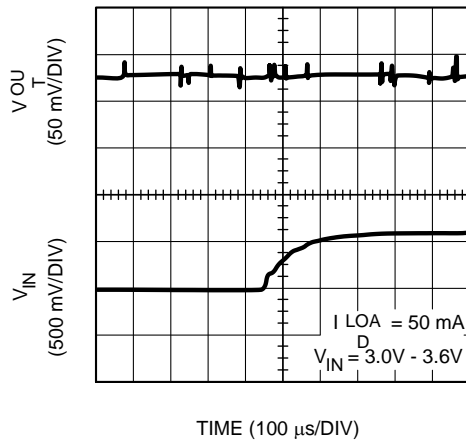

Figure 15. Boost Line Regulation

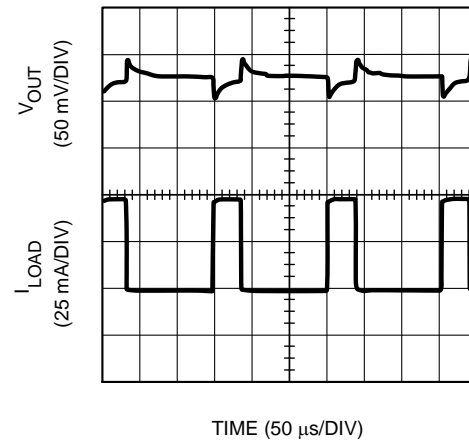

Figure 16. Boost Load Regulation, 50 mA-100 mA

Multiple RGB LED Drivers

The RGB driver has six outputs that can independently drive 2 separate RGB LEDs or six LEDs of any kind. User has control over the following parameters separately for each LED:

- **ON and OFF** (start and stop time in blinking cycle)
- **DUTY** (PWM brightness control)
- **SLOPE** (dimming slope)
- **ENABLE** (output enable control)

The main blinking cycle is controlled with 2-bit CYCLE control (0.25 / 0.5 / 1.0 / 2.0s).

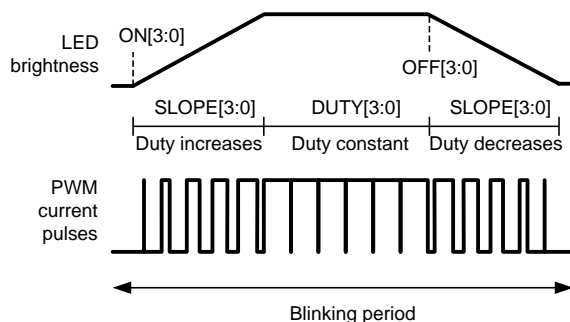

Figure 17. RGB PWM Operating Principle

RGB_START is the master enable control for the whole RGB function. The internal PWM and blinking control can be disabled by setting the RGB_PWM control LOW. In this case the individual enable controls can be used to switch outputs on and off. PWM_LED input can be used for external hardware PWM control.

In the normal PWM mode the R, G and B switches are controlled in 3 phases (one phase per driver). During each phase the peak current set by the external ballast resistor is driven through the LED for the time defined by DUTY setting (0 μ s–50 μ s). As a time averaged current this means 0%–33% of the peak current. The PWM period is 150 μ s and the pulse frequency is 6.67 kHz in normal mode.

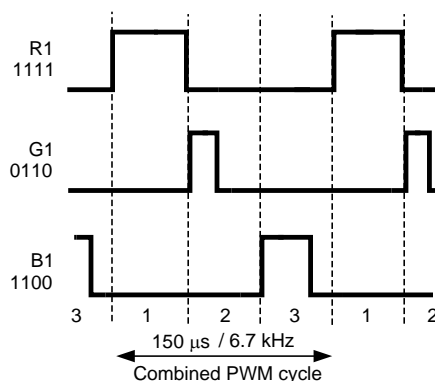

Figure 18. Normal Mode PWM Waveforms at Different Duty Settings

In the FLASH mode all the outputs are controlled in one phase and the PWM period is 50 μ s. The time averaged FLASH mode current is three times the normal mode current at the same DUTY value.

Blinking can be controlled separately for each output.

ON and OFF times define, when a LED turns on and off within the blinking cycle. When both ON and OFF are 0, the LED is on and doesn't blink. If ON equals OFF but is not 0, the LED is turned off.

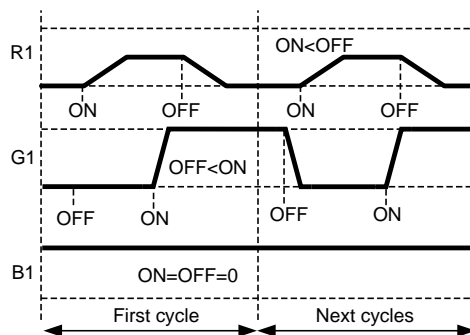

Figure 19. Example Blinking Waveforms

Application Note AN-1291 (literature number [SNVA069](#)) describes in detail the RGB driver functionality of LP3933. The RGB driver in LP3931 is identical with LP3933.

RGB Driver Electrical Characteristics⁽¹⁾

Symbol	Parameter	Conditions	Min	Typ	Max	Units
R_{DS-ON}	ON Resistance			3.5	6	Ω
$I_{LEAKAGE}$	Off State Leakage Current	$V_{FB} = 5V$, LED driver off		0.03	1	μA
I_{MAX}	Maximum Sink Current	⁽²⁾			120	mA
T_{SMAX}	Maximum Slope Period	At Maximum Duty Setting		0.93		s
T_{SMIN}	Minimum Slope Period	At Maximum Duty Setting		31		ms
T_{SRES}	Slope Resolution	At Maximum Duty Setting		62		ms
$T_{START/STOP}$	Start/Stop Resolution	Cycle 1s		1/16		s
Duty	Duty Step Size			1/16		
T_{BLINK}	Blinking Cycle Accuracy		-6	± 3	+6	%
D_{CYCF}	Duty Cycle Range	EN_FLASH = 1	0		99.6	%
D_{CYC}	Duty Cycle Range	EN_FLASH = 0	0		33.2	%
D_{RESF}	Duty Resolution	EN_FLASH = 1 (4-bit)		6.64		%
D_{RES}	Duty Resolution	EN_FLASH = 0 (4-bit)		2.21		%
F_{PWMF}	PWM Frequency	EN_FLASH = 1		20		kHz
F_{PWM}	PWM Frequency	EN_FLASH = 0		6.67		kHz

(1) (R1, G1, B1, R2, G2, B2 outputs)

(2) The total load current of the boost converter should be limited to 300 mA.

RGB LED PWM Control ⁽¹⁾

R1DUTY[3:0] G1DUTY[3:0] B1DUTY[3:0] R2DUTY[3:0] G2DUTY[3:0] B2DUTY[3:0]	DUTY sets the brightness of the LED by adjusting the duty cycle of the PWM driver. The minimum DUTY cycle is 0% [0000] and the maximum in the Flash mode is ~ 100% [1111] of peak pulse current. The peak pulse current is determined by the external resistor, LED forward voltage drop and the boost voltage. In normal mode the maximum duty cycle is 33%.
R1SLOPE[3:0] G1SLOPE[3:0] B1SLOPE[3:0] R2SLOPE[3:0] G2SLOPE[3:0] B2SLOPE[3:0]	SLOPE sets the turn-on and turn-off slopes. Fastest slope is set by [0000] and slowest by [1111]. SLOPE changes the duty cycle at constant, programmable rate. For each slope setting the maximum slope time appears at maximum DUTY setting. When DUTY is reduced, the slope time decreases proportionally. For example, in case of maximum DUTY, the sloping time can be adjusted from 31 ms [0000] to 930 ms [1111]. For 50% DUTY [0111] the sloping time is 14 ms [0000] to 434 ms [1111]. The blinking cycle has no effect on SLOPE.

(1) Application Note 1291, "Driving RGB LEDs Using LP3933 Lighting Management System" (literature number [SNVA069](#)) contains a thorough description of the RGB driver functionality including programming examples. It applies to LP3931, too.

RGB LED PWM Control ⁽¹⁾ (continued)

R1ON[3:0] G1ON[3:0] B1ON[3:0] R2ON[3:0] G2ON[3:0] B2ON[3:0]	ON sets the beginning time of the turn-on slope. The on-time is relative to the selected blinking cycle length. On-setting N (N = 0 – 15) sets the on-time to N/16 * cycle length.
R1OFF[3:0] G1OFF[3:0] B1OFF[3:0] R2OFF[3:0] G2OFF[3:0] B2OFF[3:0]	OFF sets the beginning time of the turn-off slope. Off-time is relative to the blinking cycle length in the same way as the on-time.
	If ON = 0 , OFF = 0 and RGB_PWM = 1 , then the RGB outputs are continuously on (no blinking), the DUTY setting controls the brightness and the SLOPE control is ignored. If ON and OFF are the same, but not 0 , the RGB outputs are turned off.
CYCLE[1:0]	CYCLE sets the blinking cycle: [00] for 0.25s, [01] for 0.5s, [10] for 1s and [11] for 2s. CYCLE effects to all RGB LEDs.
RSW1 GSW1 BSW1 RSW2 GSW2 BSW2	Enable for R1 switch Enable for G1 switch Enable for B1 switch Enable for R2 switch Enable for G2 switch Enable for B2 switch
RGB_START	Master Switch: RGB_START = 0 → RGB OFF RGB_START = 1 → RGB ON, starts the new cycle from t = 0
RGB_PWM	RGB_PWM = 0 → RSW, GWS and BSW control directly the RGB outputs (on/off control only) RGB_PWM = 1 → Normal PWM RGB functionality (duty, slope, on/off times, cycle)
EN_FLASH1 EN_FLASH2	Flash Mode enable controls for RGB1 and RGB2. In Flash mode (EN_FLASH = 1) RGB outputs are PWM controlled simultaneously, not in 3-phase system as in the Normal Mode.
R1_PWM G1_PWM B1_PWM R2_PWM G2_PWM B2_PWM	XX_PWM = 0 → External PWM control from PWM_LED pin is disabled XX_PWM = 1 → External PWM control from PWM_LED pin is enabled Internal PWM control (DUTY) can be used independently of external PWM control. External PWM has the same effect on all enabled outputs.

Recommended External Components

Output Capacitor, C_{OUT}

The output capacitor C_{OUT} directly affects the magnitude of the output ripple voltage so C_{OUT} should be carefully selected. In general, the higher the value of C_{OUT} , the lower the output ripple magnitude. Multilayer ceramic capacitors with low ESR are the best choice. At the lighter loads, the low ESR ceramics offer a much lower V_{OUT} ripple than the higher ESR tantalums of the same value. At the higher loads, the ceramics offer a slightly lower V_{OUT} ripple magnitude than the tantalums of the same value. However, the dv/dt of the V_{OUT} ripple with the ceramics is much lower than the tantalums under all load conditions. Capacitor voltage rating must be sufficient, 10V or greater is recommended.

Input Capacitor, C_{IN}

The input capacitor C_{IN} directly affects the magnitude of the input ripple voltage and to a lesser degree the V_{OUT} ripple. A higher value C_{IN} will give a lower V_{IN} ripple. Capacitor voltage rating must be sufficient, 10V or greater is recommended.

Output Diode, D_{OUT}

A Schottky diode should be used for the output diode. To maintain high efficiency the average current rating of the schottky diode should be larger than the peak inductor current (1A). Schottky diodes with a low forward drop and fast switching speeds are ideal for increasing efficiency in portable applications. Choose a reverse breakdown of the schottky diode larger than the output voltage. Do not use ordinary rectifier diodes, since slow switching speeds and long recovery times cause the efficiency and the load regulation to suffer.

Inductor, L

The LP3931's high switching frequency enables the use of the small surface mount inductor. A 10 μ H shielded inductor is suggested. The inductor should have a saturation current rating higher than the peak current it will experience during circuit operation (\sim 1A). Less than 100 m Ω ESR is suggested for high efficiency. Open core inductors cause flux linkage with circuit components and interfere with the normal operation of the circuit. This should be avoided. For high efficiency, choose an inductor with a high frequency core material such as ferrite to reduce the core losses. To minimize radiated noise, use a toroid, pot core or shielded core inductor. The inductor should be connected to the OUT pin as close to the IC as possible. Examples of suitable inductors are TDK types LLF4017T-100MR90C and VLF4012AT-100MR79 and Coilcraft type DO3314T-103 (unshielded).

Table 1. List of External Components

Symbol	Symbol Explanation	Value	Unit	Recommended Type
C_{VDD1}	V_{DD1} Bypass Capacitor	100	nF	Ceramic, X7R
C_{VDD2}	V_{DD2} Bypass Capacitor	100	nF	Ceramic, X7R
C_{OUT}	Output Capacitor from FB to GND	10	μ F	Ceramic, X7R/Y5V
C_{IN}	Input Capacitor from Battery Voltage to GND	10	μ F	Ceramic, X7R/Y5V
C_{VDDIO}	V_{DD_IO} Bypass Capacitor	100	nF	Ceramic, X7R
RT	Oscillator Frequency Bias Resistor	82	k Ω	1% ⁽¹⁾
RSO	SO Output Pull-up Resistor	100	k Ω	
C_{VREF}	Reference Voltage Capacitor, between V_{REF} and GND	100	nF	Ceramic, X7R
L_{BOOST}	Boost Converter Inductor	10	μ H	Shielded, Low ESR, $I_{SAT} \sim$ 1A
D_{OUT}	Rectifying Diode, V_F @ Maxload	0.3	V	Schottky Diode
RGB1	RGB LED1	User Defined (See Application Note AN-1291 (literature number SNVA069) for resistor size calculation)		
RGB2	RGB LED2			
R_{R1}, R_{G1}, R_{B1}	Current Limit Resistor			
R_{R2}, R_{G2}, R_{B2}	Current Limit Resistor			
LEDs	White LEDs			

(1) Resistor RT accuracy specification change from 1% \rightarrow 5% will be seen on timing accuracy of RGB block. Also the boost converter's switching frequency will be affected.

Control Registers

Control registers and register bits are shown in the following table.

ADDR	REGISTER	D7	D6	D5	D4	D3	D2	D1	D0
00H	RGB Control register1	rgb pwm	rgb start	rsw1	gsw1	bsw1	rsw2	gsw2	bsw2
01H	red1_on_off	r1_on[3]	r1_on[2]	r1_on[1]	r1_on[0]	r1_off[3]	r1_off[2]	r1_off[1]	r1_off[0]
02H	green1_on_off	g1_on[3]	g1_on[2]	g1_on[1]	g1_on[0]	g1_off[3]	g1_off[2]	g1_off[1]	g1_off[0]
03H	blue1_on_off	b1_on[3]	b1_on[2]	b1_on[1]	b1_on[0]	b1_off[3]	b1_off[2]	b1_off[1]	b1_off[0]
04H	r1slope, r1duty	r1slope[3]	r1slope[2]	r1slope[1]	r1slope[0]	r1duty[3]	r1duty[2]	r1duty[1]	r1duty[0]
05H	g1slope, g1duty	g1slope[3]	g1slope[2]	g1slope[1]	g1slope[0]	g1duty[3]	g1duty[2]	g1duty[1]	g1duty[0]
06H	b1slope, b1duty	b1slope[3]	b1slope[2]	b1slope[1]	b1slope[0]	b1duty[3]	b1duty[2]	b1duty[1]	b1duty[0]
07H	RGB Control register2	cycle[1]	cycle[0]	r1_pwm	g1_pwm	b1_pwm	r2_pwm	g2_pwm	b2_pwm
0BH	enables		nstby	en_boost	en_flash1	en_flash2			
0DH	boost output	boost[7]	boost[6]	boost[5]	boost[4]	boost[3]	boost[2]	boost[1]	boost[0]
2AH	red2_on_off	r2_on[3]	r2_on[2]	r2_on[1]	r2_on[0]	r2_off[3]	r2_off[2]	r2_off[1]	r2_off[0]
2BH	green2_on_off	g2_on[3]	g2_on[2]	g2_on[1]	g2_on[0]	g2_off[3]	g2_off[2]	g2_off[1]	g2_off[0]
2CH	blue2_on_off	b2_on[3]	b2_on[2]	b2_on[1]	b2_on[0]	b2_off[3]	b2_off[2]	b2_off[1]	b2_off[0]
2DH	r2slope, r2duty	r2slope[3]	r2slope[2]	r2slope[1]	r2slope[0]	r2duty[3]	r2duty[2]	r2duty[1]	r2duty[0]
2EH	g2slope, g2duty	g2slope[3]	g2slope[2]	g2slope[1]	g2slope[0]	g2duty[3]	g2duty[2]	g2duty[1]	g2duty[0]
2FH	b2slope, b2duty	b2slope[3]	b2slope[2]	b2slope[1]	b2slope[0]	b2duty[3]	b2duty[2]	b2duty[1]	b2duty[0]

Application Examples

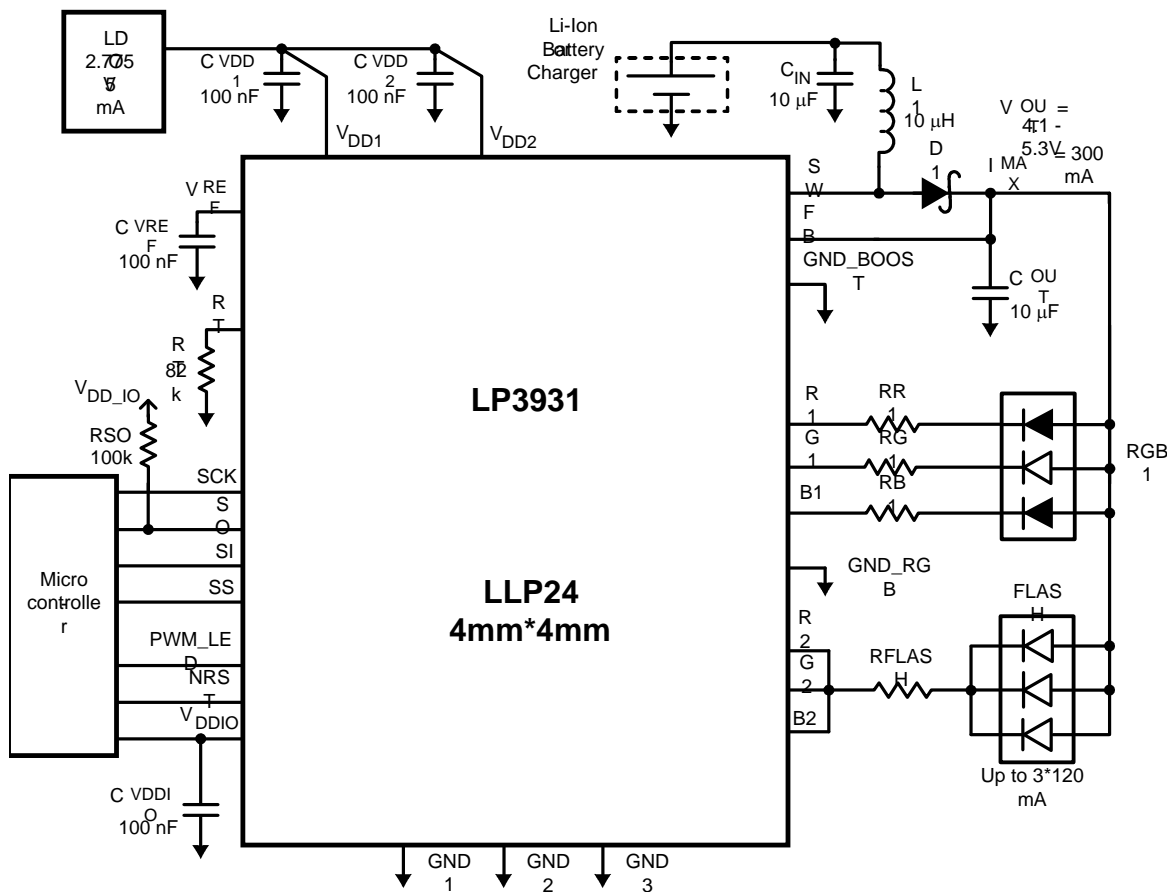

Figure 20. LP3931 with One RGB and One FLASH LED

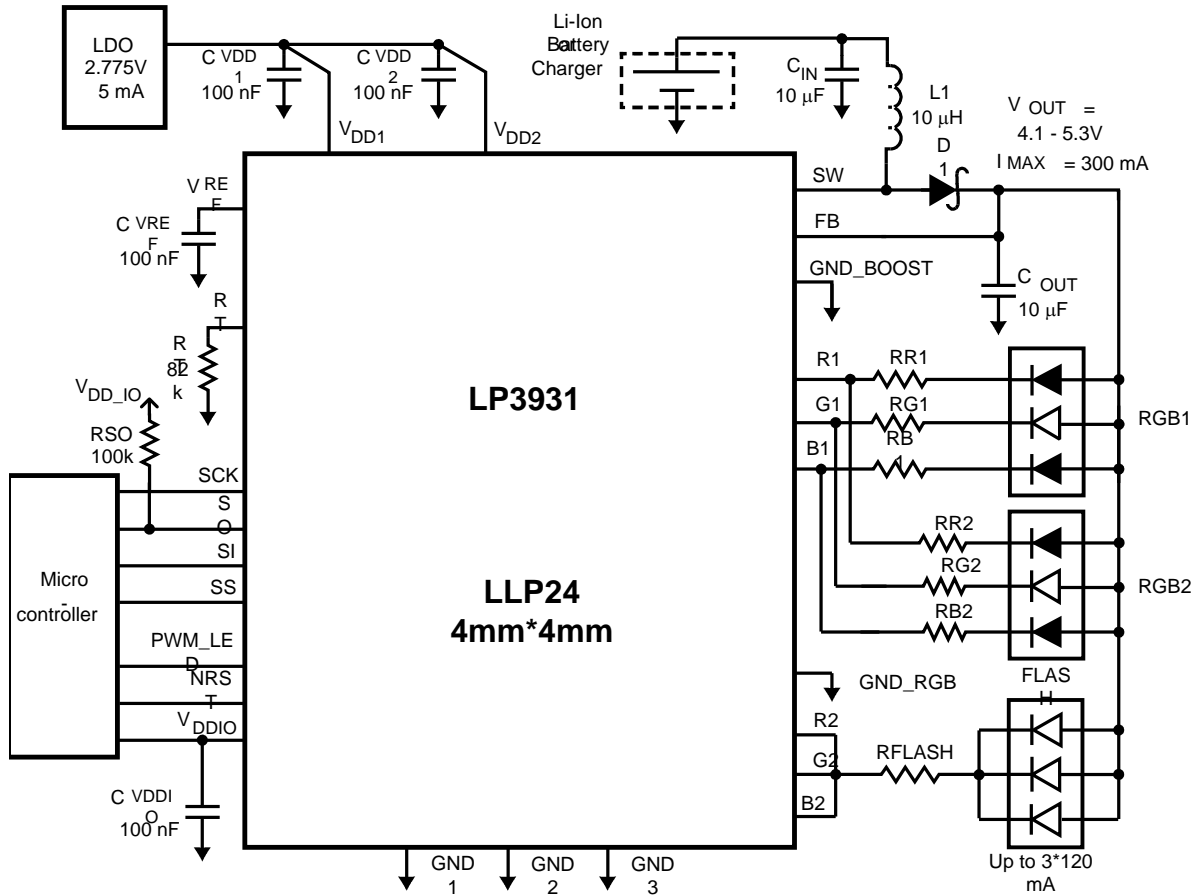

Figure 21. LP3931 with Two RGB and One FLASH LED

REVISION HISTORY

Changes from Revision A (April 2013) to Revision B	Page
• Changed layout of National Data Sheet to TI format	19

IMPORTANT NOTICE

Texas Instruments Incorporated and its subsidiaries (TI) reserve the right to make corrections, enhancements, improvements and other changes to its semiconductor products and services per JESD46, latest issue, and to discontinue any product or service per JESD48, latest issue. Buyers should obtain the latest relevant information before placing orders and should verify that such information is current and complete. All semiconductor products (also referred to herein as "components") are sold subject to TI's terms and conditions of sale supplied at the time of order acknowledgment.

TI warrants performance of its components to the specifications applicable at the time of sale, in accordance with the warranty in TI's terms and conditions of sale of semiconductor products. Testing and other quality control techniques are used to the extent TI deems necessary to support this warranty. Except where mandated by applicable law, testing of all parameters of each component is not necessarily performed.

TI assumes no liability for applications assistance or the design of Buyers' products. Buyers are responsible for their products and applications using TI components. To minimize the risks associated with Buyers' products and applications, Buyers should provide adequate design and operating safeguards.

TI does not warrant or represent that any license, either express or implied, is granted under any patent right, copyright, mask work right, or other intellectual property right relating to any combination, machine, or process in which TI components or services are used. Information published by TI regarding third-party products or services does not constitute a license to use such products or services or a warranty or endorsement thereof. Use of such information may require a license from a third party under the patents or other intellectual property of the third party, or a license from TI under the patents or other intellectual property of TI.

Reproduction of significant portions of TI information in TI data books or data sheets is permissible only if reproduction is without alteration and is accompanied by all associated warranties, conditions, limitations, and notices. TI is not responsible or liable for such altered documentation. Information of third parties may be subject to additional restrictions.

Resale of TI components or services with statements different from or beyond the parameters stated by TI for that component or service voids all express and any implied warranties for the associated TI component or service and is an unfair and deceptive business practice. TI is not responsible or liable for any such statements.

Buyer acknowledges and agrees that it is solely responsible for compliance with all legal, regulatory and safety-related requirements concerning its products, and any use of TI components in its applications, notwithstanding any applications-related information or support that may be provided by TI. Buyer represents and agrees that it has all the necessary expertise to create and implement safeguards which anticipate dangerous consequences of failures, monitor failures and their consequences, lessen the likelihood of failures that might cause harm and take appropriate remedial actions. Buyer will fully indemnify TI and its representatives against any damages arising out of the use of any TI components in safety-critical applications.

In some cases, TI components may be promoted specifically to facilitate safety-related applications. With such components, TI's goal is to help enable customers to design and create their own end-product solutions that meet applicable functional safety standards and requirements. Nonetheless, such components are subject to these terms.

No TI components are authorized for use in FDA Class III (or similar life-critical medical equipment) unless authorized officers of the parties have executed a special agreement specifically governing such use.

Only those TI components which TI has specifically designated as military grade or "enhanced plastic" are designed and intended for use in military/aerospace applications or environments. Buyer acknowledges and agrees that any military or aerospace use of TI components which have **not** been so designated is solely at the Buyer's risk, and that Buyer is solely responsible for compliance with all legal and regulatory requirements in connection with such use.

TI has specifically designated certain components as meeting ISO/TS16949 requirements, mainly for automotive use. In any case of use of non-designated products, TI will not be responsible for any failure to meet ISO/TS16949.

Products

Audio	www.ti.com/audio
Amplifiers	amplifier.ti.com
Data Converters	dataconverter.ti.com
DLP® Products	www.dlp.com
DSP	dsp.ti.com
Clocks and Timers	www.ti.com/clocks
Interface	interface.ti.com
Logic	logic.ti.com
Power Mgmt	power.ti.com
Microcontrollers	microcontroller.ti.com
RFID	www.ti-rfid.com
OMAP Applications Processors	www.ti.com/omap
Wireless Connectivity	www.ti.com/wirelessconnectivity

Applications

Automotive and Transportation	www.ti.com/automotive
Communications and Telecom	www.ti.com/communications
Computers and Peripherals	www.ti.com/computers
Consumer Electronics	www.ti.com/consumer-apps
Energy and Lighting	www.ti.com/energy
Industrial	www.ti.com/industrial
Medical	www.ti.com/medical
Security	www.ti.com/security
Space, Avionics and Defense	www.ti.com/space-avionics-defense
Video and Imaging	www.ti.com/video

TI E2E Community

e2e.ti.com