

LM25007 42V, 0.5A Step-Down Switching Regulator

Check for Samples: [LM25007](#)

FEATURES

- **Integrated 0.74Ω N-Channel MOSFET Switch**
- **Guaranteed 0.5A Output Current**
- **Ultra-Fast Transient Response**
- **Up to 800kHz Operation**
- **No Control Loop Compensation Required**
- **Vin Feed Forward Provides Constant Operating Frequency**
- **2% Accurate 2.5V Feedback from -40°C to 125°C**
- **Highly Efficient Operation**
- **Intelligent Current Limit Protection**
- **External Shutdown Control**
- **Thermal Shutdown**
- **VSSOP and Thermally Enhanced WSON Packages**

TYPICAL APPLICATIONS

- **12VDC and 24VDC Distributed Rail Systems**
- **24VAC Systems**
- **Automotive Body Electronics and Telematics**
- **Industrial Systems**
- **HB-LED Constant Current Source**
- **Package:**
 - **VSSOP-8**
 - **WSON-8 (4mm x 4mm)**

DESCRIPTION

The LM25007 is a monolithic step-down switching regulator featuring all of the functions needed to implement a low cost, efficient, power supply. Capable of driving a 0.5A load over a 9V-42V input voltage range, this device is easy to apply and is provided in the small VSSOP-8 and the thermally enhanced WSON-8 packages. Ultra-fast transient response is achieved through the use of a constant on-time architecture with Vin feed forward. This feature provides an almost constant operating frequency over load and input voltage variations. The operating frequency can be adjusted with a single resistor. This architecture is easy to use and tolerant of component selection. An intelligent current limit is implemented in the LM25007 with forced off time that is inversely proportional to Vout thus ensuring recovery from fault conditions. The output voltage may be set from 2.5V to >30V. To improve efficiency in light load applications, the Vcc pin can be connected to an external voltage source to eliminate the drop through the internal regulator. Additional features include: thermal shutdown, Vcc under-voltage lockout, gate drive under-voltage lockout, and max duty cycle limiter.



Please be aware that an important notice concerning availability, standard warranty, and use in critical applications of Texas Instruments semiconductor products and disclaimers thereto appears at the end of this data sheet.

All trademarks are the property of their respective owners.

Basic Step-Down Regulator

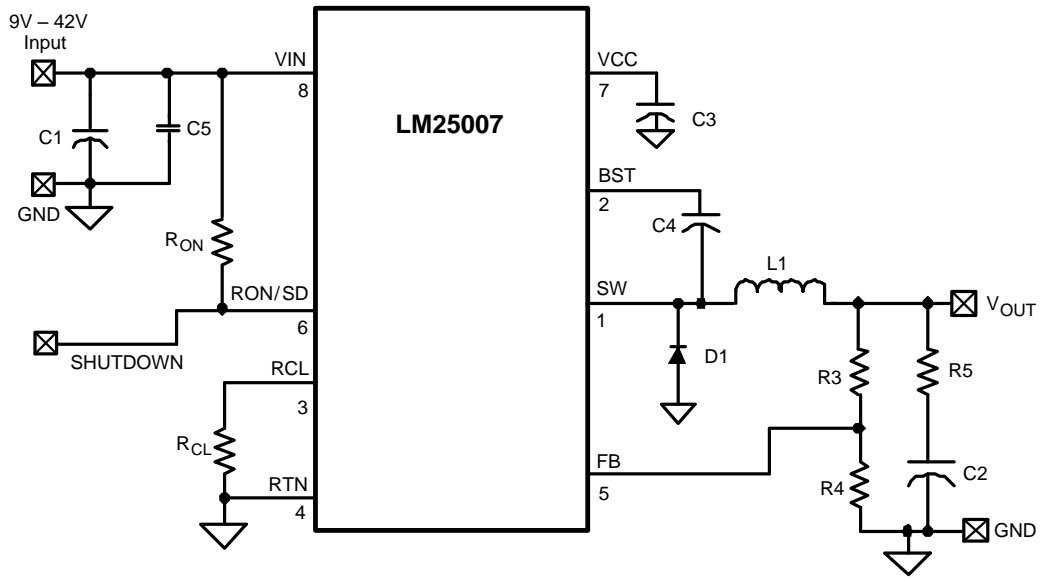

Connection Diagram

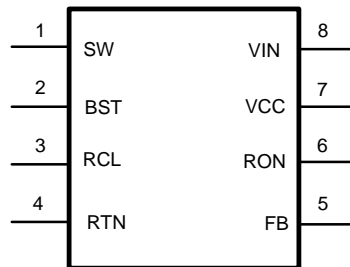

8-Lead VSSOP, WSON

Pin Descriptions

Pin	Name	Description	Application Information
1	SW	Switching Node	Power switching node. Connect to the inductor, bootstrap capacitor, and free-wheeling diode.
2	BST	Boost Boot-strap capacitor input	An external capacitor is required between the BST and the SW pins. A 0.01µF ceramic capacitor is recommended.
3	RCL	Current Limit OFF time programming pin	A resistor between this pin and RTN sets the off-time when current limit is detected. The off-time is preset to 17 µs if FB = 0V .
4	RTN	Circuit Ground	
5	FB	Feedback Signal from Regulated Output	This pin is connected to the inverting input of the internal regulation comparator. The regulation threshold is 2.5V.
6	RON/SD	On-time set pin	A resistor between this pin and VIN sets the switch on-time as a function of Vin. The minimum recommended on-time is 300ns at the maximum input voltage.
7	VCC	Output from the internal high voltage bias regulator.	If an auxiliary voltage is available to raise the voltage on this pin above the regulation setpoint (7V), the internal series pass regulator will shutdown, reducing the IC power dissipation. Do not exceed 14V. This output provides gate drive power for the internal Buck switch. An internal diode is provided between this pin and the BST pin. A local 0.1µF decoupling capacitor is recommended.
8	VIN	Input supply voltage	Recommended operating range: 9V to 42V.
-	EP	Exposed pad, underside of the WSON package option	Exposed metal pad on the WSON package underside. It is recommended to connect this pad to the PC board ground plane to aid in heat dissipation.

Typical Application Circuit and Block Diagram

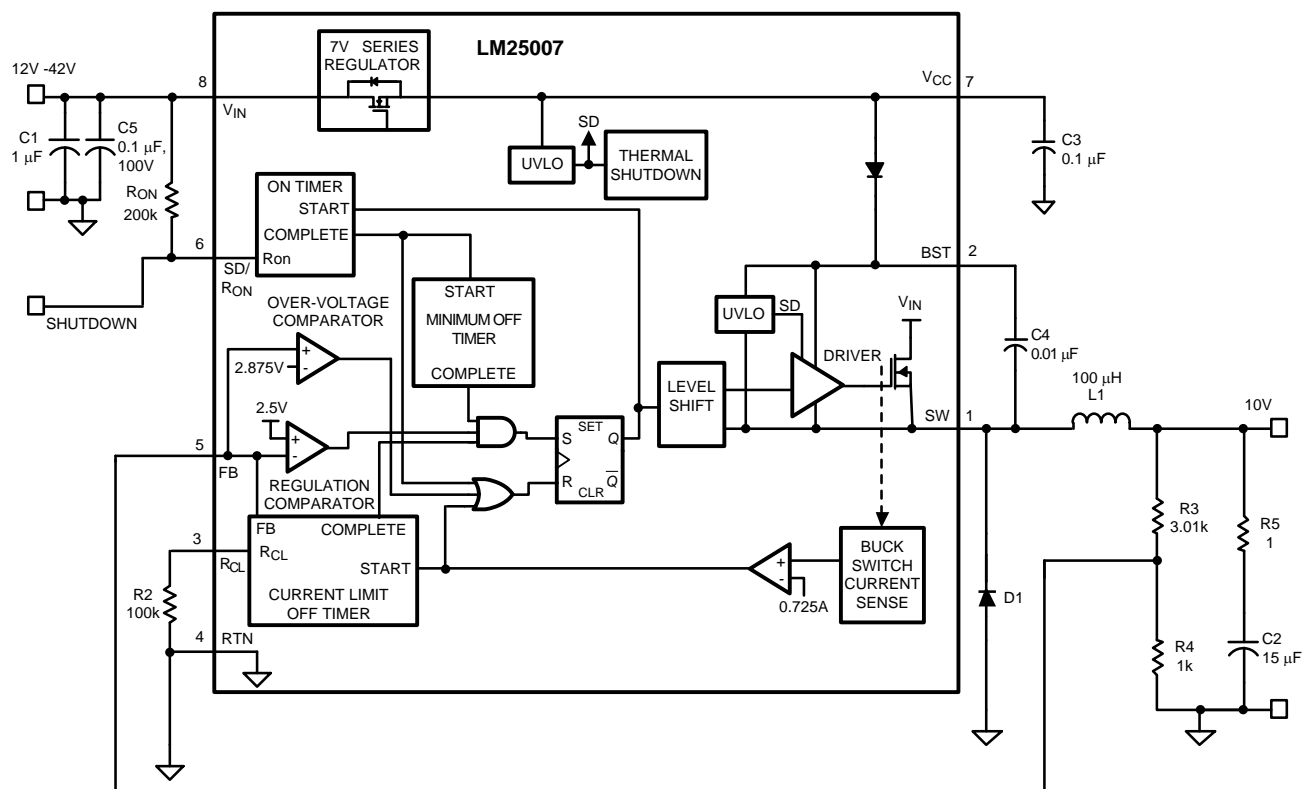



These devices have limited built-in ESD protection. The leads should be shorted together or the device placed in conductive foam during storage or handling to prevent electrostatic damage to the MOS gates.

Absolute Maximum Ratings⁽¹⁾

V _{IN} to RTN	45V
BST to RTN	59V
SW to RTN (Steady State)	-1V
ESD Rating, Human Body Model ⁽²⁾	2kV
BST to V _{CC}	45V
BST to SW	14V
V _{CC} to RTN	14V
All Other Inputs to RTN	-0.3 to 7V
Storage Temperature Range	-65°C to +150°C

- (1) [Absolute Maximum Ratings](#) are limits beyond which damage to the device may occur. [Operating Ratings](#) are conditions under which operation of the device is intended to be functional. For guaranteed specifications and test conditions, see the [Electrical Characteristics](#).
- (2) The human body model is a 100pF capacitor discharge through a 1.5kΩ resistor into each pin. The human body ESD compliance level for Pin 7 and 8 is 1000V.

Operating Ratings⁽¹⁾

V _{IN}	9V to 42V
Junction Temperature	-40°C to + 125°C

- (1) [Absolute Maximum Ratings](#) are limits beyond which damage to the device may occur. [Operating Ratings](#) are conditions under which operation of the device is intended to be functional. For guaranteed specifications and test conditions, see the [Electrical Characteristics](#).

Electrical Characteristics⁽¹⁾

Specifications with standard type are for $T_J = 25^\circ\text{C}$ only; limits in boldface type apply over the full Operating Junction Temperature (T_J) range. Minimum and Maximum limits are guaranteed through test, design, or statistical correlation. Typical values represent the most likely parametric norm at $T_J = 25^\circ\text{C}$, and are provided for reference purposes only. Unless otherwise stated the following conditions apply: $V_{IN} = 24\text{V}$, $R_{ON} = 200\text{k}\Omega$.

Symbol	Parameter	Conditions	Min	Typ	Max	Unit
Startup Regulator						
V_{CC} Reg	V_{CC} Regulator Output		6.6	7	7.4	V
	V_{CC} Current Limit	(2)		11		mA
V_{CC} Supply						
	V_{CC} undervoltage Lockout Voltage (V_{CC} increasing)			6.3		V
	V_{CC} Undervoltage Hysteresis			206		mV
	V_{CC} UVLO Delay (filter)			3		μs
	Operating Current (I_{CC})	Non-Switching, $\text{FB} = 3\text{V}$		500	675	μA
	Shutdown/Standby Current	$R_{ON}/SD = 0\text{V}$		70	150	μA
Switch Characteristics						
	Buck Switch $R_{ds(on)}$	$I_{TEST} = 200\text{mA}$, $V_{BST} - V_{SW} = 6.3\text{V}^{(3)}$		0.74	1.34	Ω
	Gate Drive UVLO ($V_{BST} - V_{SW}$)	Rising	3.4	4.5	5.5	V
	Gate Drive UVLO Hysteresis			400		mV
Current Limit						
	Current Limit Threshold		535	725	900	mA
	Current Limit Response Time	I_{switch} Overdrive = 0.1A Time to Switch Off		225		ns
	OFF time generator (test 1)	$\text{FB}=0\text{V}$, $\text{RCL} = 100\text{K}$		17		μs
	OFF time generator (test 2)	$\text{FB}=2.3\text{V}$, $\text{RCL} = 100\text{K}$		2.65		μs
On Time Generator						
	TON -1	$V_{in} = 10\text{V}$ $R_{on} = 200\text{K}$	2.15	2.77	3.5	μs
	TON -2	$V_{in} = 40\text{V}$ $R_{on} = 200\text{K}$	450	615	810	ns
	Remote Shutdown Threshold	Rising	0.45	0.7	1.1	V
	Remote Shutdown Hysteresis			40		mV
Minimum Off Time						
	Minimum Off Timer	$\text{FB} = 0\text{V}$		300		ns
Regulation and OV Comparators						
	FB Reference Threshold	Internal reference Trip point for switch ON	2.445	2.5	2.550	V
	FB Over-Voltage Threshold	Trip point for switch OFF		2.875		V
	FB Bias Current			100		nA
Thermal Shutdown						
T_{sd}	Thermal Shutdown Temp.			165		$^\circ\text{C}$
	Thermal Shutdown Hysteresis			25		$^\circ\text{C}$
Thermal Resistance						
θ_{JA}	Junction to Ambient	DGK Package		200		$^\circ\text{C}/\text{W}$
		NGT Package		40		$^\circ\text{C}/\text{W}$

- (1) All limits are guaranteed. All electrical characteristics having room temperature limits are tested during production with $T_A = T_J = 25^\circ\text{C}$. All hot and cold limits are guaranteed by correlating the electrical characteristics to process and temperature variations and applying statistical process control.
- (2) The V_{CC} output is intended as a self bias for the internal gate drive power and control circuits. Device thermal limitations limit external loading.
- (3) For devices procured in the WSON-8 package the $R_{ds(on)}$ limits are guaranteed by design characterization data only.

Typical Performance Characteristics

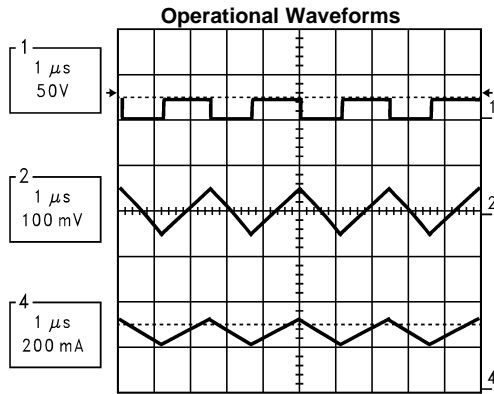

LM25007 Operation: $V_{OUT} = 10V$, $V_{IN} = 20V$, $I_{OUT} = 250mA$
 CH1: Switch Node, CH2: V_{OUT} (AC), CH4: Inductor Current

Figure 1.

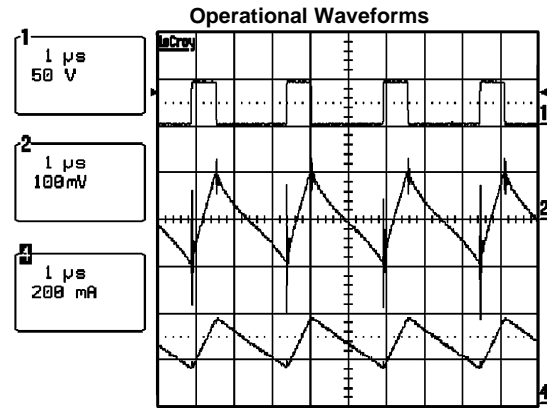

LM25007 Operation: $V_{OUT} = 10V$, $V_{IN} = 42V$, $I_{OUT} = 250mA$
 CH1: Switch Node, CH2: V_{OUT} (AC), CH4: Inductor Current

Figure 2.

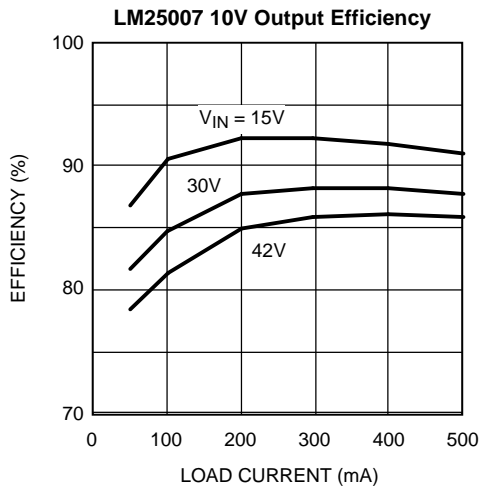

Figure 3.

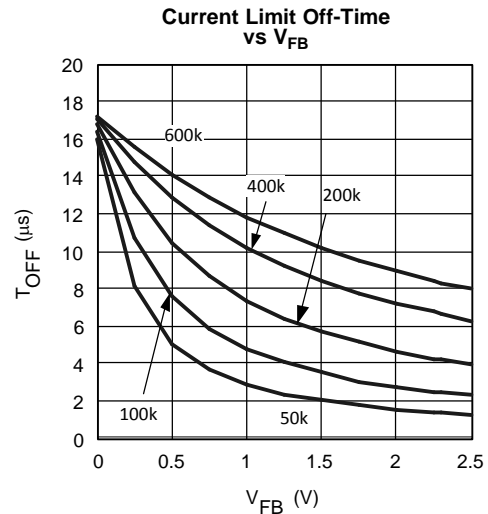

Figure 4.

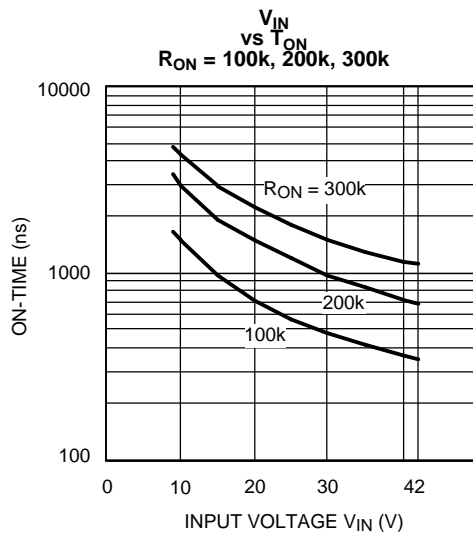

Figure 5.

DETAILED OPERATING DESCRIPTION

The LM25007 is a monolithic step-down switching regulator featuring all of the functions needed to implement low cost, efficient, power supply. Capable of driving a 0.5Amp load over a 9-42V input voltage range, this device is easy to apply and is provided in the small VSSOP-8 and the thermally enhanced WSON-8 packages. Ultra-fast transient response is achieved through the use of a constant on-time architecture with Vin feed forward. This feature provides an almost constant operating frequency over load and input voltage variations. The operating frequency may be adjusted up to 800kHz depending on input and output voltages. This architecture is easy to use and tolerant of component selection. An intelligent current limit is implemented in the LM25007 with forced off time that is inversely proportional to Vout to ensure recovery from fault conditions. The output voltage may be set from 2.5V to >30V. To improve efficiency in light load applications, the Vcc pin can be tied to an external voltage source thus eliminating the drop through the integrated internal regulator. Additional protection features include: thermal shutdown, Vcc under-voltage lockout, gate drive under-voltage lockout, and max duty cycle limiter.

Hysteretic Control Circuit Overview

The LM25007 is a Buck DC-DC regulator that uses a constant on-time control scheme. The on-time is programmed by an external resistor and varies inversely with line input voltage (Vin). The core regulation elements of the LM25007 are the feedback comparator and the on-time one-shot. The regulator output voltage is sensed at the feedback pin (FB) and is compared to an internal reference voltage (2.5V). If the FB signal is below the reference voltage, the buck switch is turned on for a fixed time pulse determined by the line voltage and a programming resistor (RON). Following the on period the switch will remain off for at least the minimum off timer period of 300ns. If the FB pin voltage is still below the reference after the 300ns off-time, the switch will turn on again for another on time period. This switching behavior will continue until the FB pin voltage reaches the reference voltage level.

The LM25007 operates in discontinuous conduction mode at light load currents or continuous conduction mode at heavier load currents. In discontinuous conduction mode, current through the output inductor starts at zero and ramps up to a peak value during the buck switch on-time and then back to zero during the off-time. The inductor current remains at zero until the next on-time period starts when FB falls below the internal reference. In discontinuous mode the operating frequency is relatively low and will vary with load. Therefore at light loads the conversion efficiency is maintained, since the switching losses decrease with the reduction in load current and switching frequency. The approximate discontinuous mode operating frequency can be calculated as follows:

$$F = \frac{V_{OUT}^2 \times L}{1 \times 10^{-20} \times R_{Load} \times (R_{ON})^2} \quad (1)$$

In continuous conduction mode, current flows continuously through the inductor and never ramps down to zero. In this mode the operating frequency is greater than the discontinuous mode frequency and remains relatively constant with load and line variations. The approximate continuous mode operating frequency can be calculated as follows:

$$F = \frac{V_{OUT}}{1.42 \times 10^{-10} \times R_{ON}} \quad (2)$$

The output voltage (Vout) can be programmed by two external resistors as shown in [Figure 6](#). The regulated voltage is calculated as follows:

$$V_{OUT} = 2.5 \times (R3 + R4) / R4 \quad (3)$$

The feedback comparator in hysteretic regulators depends on the output ripple voltage to switch the output transistor on and off at regular intervals. In order for the internal comparator to respond quickly to changes in output voltage, proportional to inductor current, a minimum amount of capacitor Equivalent Series Resistance (ESR) is required. A ripple voltage of 25mV is recommended at the feedback pin (FB) for stable operation. In cases where the intrinsic capacitor ESR is too small, additional series resistance may be added.

For applications where lower output voltage ripple is required the load can be connected directly to the low ESR output capacitor, as shown in Figure 6. The series resistor (R5) will degrade the load regulation. Another technique for enhancing the ripple voltage at the FB pin is to place a capacitor in parallel with the feedback divider resistor R3. The addition of the capacitor reduces the attenuation of the ripple voltage from the feedback divider.

High Voltage Bias Regulator (VCC)

The LM25007 contains an internal high voltage bias regulator. The input pin (V_{IN}) can be connected directly to line voltages from 9 to 42 Volts. To avoid supply voltage transients due to long lead inductances on the input pin (V_{IN}), it is always recommended to connect a low ESR ceramic chip capacitor ($\approx 0.1\mu\text{F}$) between V_{IN} and RTN pins located close to the LM25007. The regulator is internally current limited to 11mA. Upon power up, the regulator is enabled and sources current into an external capacitor connected to the V_{CC} pin. When the voltage on the V_{CC} pin reaches its UVLO level (6.3V), the controller output is enabled.

An external auxiliary supply voltage can be diode connected to the V_{CC} pin. If the auxiliary voltage is greater than 7 Volts the internal regulator will shutoff, thus reducing internal power dissipation. Do not exceed 14V at V_{CC} . See Figure 7.

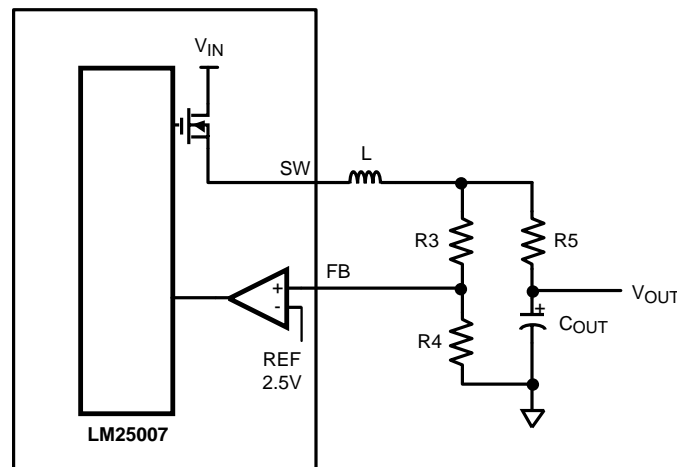

Figure 6. Low Ripple Output Configuration

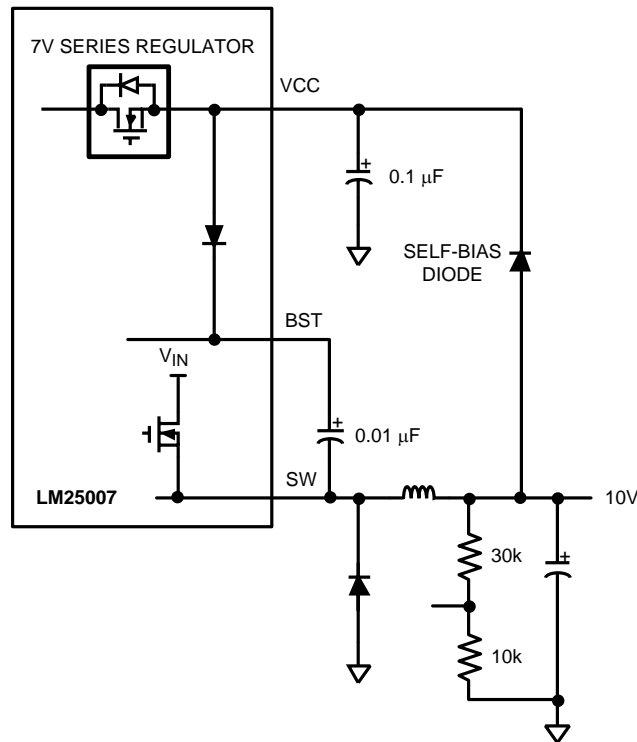

Figure 7. Self Biased Configuration

Over-Voltage Comparator

The over-voltage comparator is provided to protect the output from overvoltage conditions due to sudden input line voltage changes or output loading changes. The over-voltage comparator monitors the FB pin versus an internal 2.875V reference. If the voltage at FB rises above 2.875V the comparator immediately terminates the buck switch on-time pulse.

ON Time generator and Shutdown

The on-time of the LM25007 is set inversely proportional to the input voltage by an external resistor connected between RON/SD and VIN. The RON/SD terminal is a low impedance input biased at approximately 1.5V. The current through the resistor and into the RON/SD pin is approximately proportional to Vin and used internally to control the on-timer. This scheme of input voltage feed-forward hysteretic operation achieves nearly constant operational frequency over varying line and load conditions. The on-time equation for the LM25007 is :

$$T_{on} = 1.42 \times 10^{-10} \times R_{ON} / V_{IN} \quad (4)$$

The RON/SD pin of the LM25007 also provides a shutdown function which disables the regulator and significantly decreases quiescent power dissipation. By pulling the pin below 0.7V activates the low power shutdown mode. The VIN quiescent current in the shutdown mode is approximately 100μA internal to the LM25007 plus the current in the RON resistor. See Figure 8.

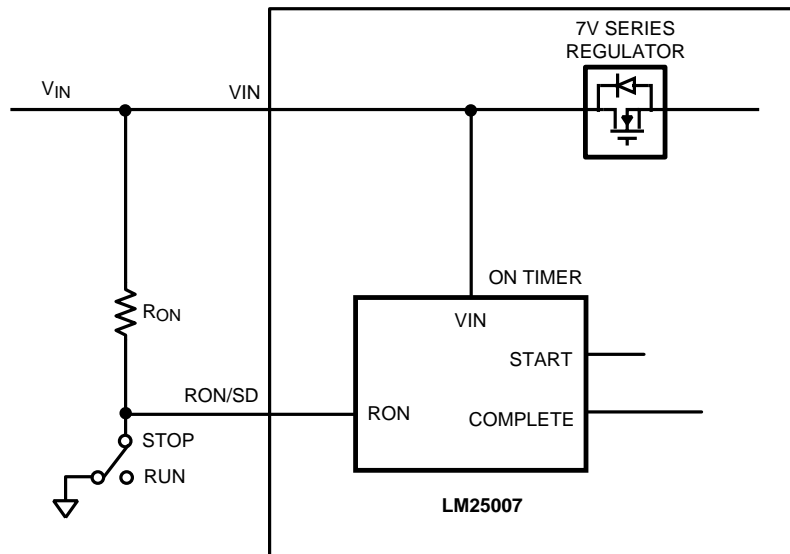

Figure 8. Shutdown Implementation

Current Limit

The LM25007 contains an intelligent current limit off-timer intended to reduce the foldback characteristic inherent with fixed off-time over-current protection. If the current in the Buck switch exceeds 725mA the present cycle on-time is immediately terminated (cycle by cycle current limit). Following the termination of the cycle a non-resettable current limit off timer is initiated. The duration of the off time is a function of the external resistor (R_{CL}) and the FB pin voltage. When the FB pin voltage equals zero, the current limit off-time is internally preset to 17 μ s. This condition occurs in short circuit operation when a maximum amount of off-time is required.

In cases of overload (not complete short circuit) the current limit off-time is reduced as a function of the output voltage (measured at the FB pin). Reducing the off-time with smaller overloads reduces the amount of foldback and also reduces the initial start-up time. The current limit off time for a given FB pin voltage and R_{CL} resistor can be calculated by the following equation:

$$T_{off} = 10^{-5} / (0.59 + (V_{FB} / 7.22 \times 10^{-6} \times R_{CL})) \quad (5)$$

Applications utilizing low resistance inductors and/or a low voltage drop rectifier may require special evaluation at high line, short circuit conditions. In this special case the preset 17 μ s ($FB = 0V$) off-time may be insufficient to balance the inductor volt*time product. Additional inductor resistance, output resistance or a larger voltage drop rectifier may be necessary to balance the inductor cycle volt*time product and limit the short circuit current.

N - Channel Buck Switch and Driver

The LM25007 integrates an N-Channel Buck switch and associated floating high voltage gate driver. The gate driver circuit works in conjunction with an external bootstrap capacitor and an internal high voltage diode. The bootstrap capacitor is charged by V_{CC} through the internal high voltage diode. A 0.01 μ F ceramic capacitor connected between the BST pin and SW pin is recommended.

During each cycle when the Buck switch turns off, the SW pin is approximately 0V. When the SW pin voltage is low, the bootstrap capacitor is charged from V_{CC} through the internal diode. The minimum off timer, set to 300ns, ensures that there will be a minimum interval every cycle to recharge the bootstrap capacitor.

An external re-circulating diode from the SW pin to ground is necessary to carry the inductor current after the internal Buck switch turns off. This external diode must be of the Ultra-fast or Schottky type to reduce turn-on losses and current over-shoot. The reverse voltage rating of the re-circulating diode must be greater than the maximum line input voltage.

Thermal Protection

Internal Thermal Shutdown circuitry is provided to protect the integrated circuit in the event the maximum junction temperature is exceeded. When thermal protection is activated, typically at 165 degrees Celsius, the controller is forced into a low power reset state, disabling the output driver. This feature is provided to prevent catastrophic failures from accidental device overheating.

Minimum Load Current

A minimum load current of 1 mA is required to maintain proper operation. If the load current falls below that level, the bootstrap capacitor may discharge during the long off-time, and the circuit will either shutdown, or cycle on and off at a low frequency. If the load current is expected to drop below 1 mA in the application, the feedback resistors should be chosen low enough in value so they provide the minimum required current at nominal V_{out} .

10V, 400mA Demo Board Bill of Materials

See [Typical Application Circuit and Block Diagram](#)

Table 1. Bill of Materials

ITEM	PART NUMBER	DESCRIPTION	VALUE
C1	C4532X7R2A105M	CAPACITOR, CER, TDK	1 μ , 100V
C2	C4532X7R1E156M	CAPACITOR, CER, TDK	15 μ , 25V
C3	C1206C104K5RAC	CAPACITOR, CER, KEMET	0.1 μ , 50V
C4	C1206C103K5RAC	CAPACITOR, CER, KEMET	0.01 μ , 50V
C5	C3216X7R2A104KT	CAPACITOR, CER, TDK	0.1 μ , 100V
D1	MURA110T3	DIODE, 100V, ON SEMI	
L1	SLF7045T-101MR60-1	BUCK INDUCTOR, TDK	100 μ H
R1	CRCW12062003F	RESISTOR	200K
R2	CRCW12061003F	RESISTOR	100K
R3	CRCW12063011F	RESISTOR	3.01K
R4	CRCW12061001F	RESISTOR	1K
R5	CRCW12061R00F	RESISTOR	1
U1	LM25007	REGULATOR, TI	

REVISION HISTORY

Changes from Revision B (February 2013) to Revision C	Page
• Changed layout of National Data Sheet to TI format	11

PACKAGING INFORMATION

Orderable Device	Status (1)	Package Type	Package Drawing	Pins	Package Qty	Eco Plan (2)	Lead/Ball Finish	MSL Peak Temp (3)	Op Temp (°C)	Top-Side Markings (4)	Samples
LM25007MM	ACTIVE	VSSOP	DGK	8	1000	TBD	Call TI	Call TI	-40 to 125	SLYB	Samples
LM25007MM/NOPB	ACTIVE	VSSOP	DGK	8	1000	Green (RoHS & no Sb/Br)	CU SN	Level-1-260C-UNLIM	-40 to 125	SLYB	Samples
LM25007MMX	ACTIVE	VSSOP	DGK	8	3500	TBD	Call TI	Call TI	-40 to 125	SLYB	Samples
LM25007MMX/NOPB	ACTIVE	VSSOP	DGK	8	3500	Green (RoHS & no Sb/Br)	CU SN	Level-1-260C-UNLIM	-40 to 125	SLYB	Samples
LM25007SD	ACTIVE	WSON	NGT	8	1000	TBD	Call TI	Call TI	-40 to 125	25007SD	Samples
LM25007SD/NOPB	ACTIVE	WSON	NGT	8	1000	Green (RoHS & no Sb/Br)	SN	Level-1-260C-UNLIM	-40 to 125	25007SD	Samples
LM25007SDX	ACTIVE	WSON	NGT	8	4500	TBD	Call TI	Call TI	-40 to 125	25007SD	Samples
LM25007SDX/NOPB	ACTIVE	WSON	NGT	8	4500	Green (RoHS & no Sb/Br)	SN	Level-1-260C-UNLIM	-40 to 125	25007SD	Samples

(1) The marketing status values are defined as follows:

ACTIVE: Product device recommended for new designs.

LIFEBUY: TI has announced that the device will be discontinued, and a lifetime-buy period is in effect.

NRND: Not recommended for new designs. Device is in production to support existing customers, but TI does not recommend using this part in a new design.

PREVIEW: Device has been announced but is not in production. Samples may or may not be available.

OBSOLETE: TI has discontinued the production of the device.

(2) Eco Plan - The planned eco-friendly classification: Pb-Free (RoHS), Pb-Free (RoHS Exempt), or Green (RoHS & no Sb/Br) - please check <http://www.ti.com/productcontent> for the latest availability information and additional product content details.

TBD: The Pb-Free/Green conversion plan has not been defined.

Pb-Free (RoHS): TI's terms "Lead-Free" or "Pb-Free" mean semiconductor products that are compatible with the current RoHS requirements for all 6 substances, including the requirement that lead not exceed 0.1% by weight in homogeneous materials. Where designed to be soldered at high temperatures, TI Pb-Free products are suitable for use in specified lead-free processes.

Pb-Free (RoHS Exempt): This component has a RoHS exemption for either 1) lead-based flip-chip solder bumps used between the die and package, or 2) lead-based die adhesive used between the die and leadframe. The component is otherwise considered Pb-Free (RoHS compatible) as defined above.

Green (RoHS & no Sb/Br): TI defines "Green" to mean Pb-Free (RoHS compatible), and free of Bromine (Br) and Antimony (Sb) based flame retardants (Br or Sb do not exceed 0.1% by weight in homogeneous material)

(3) MSL, Peak Temp. -- The Moisture Sensitivity Level rating according to the JEDEC industry standard classifications, and peak solder temperature.

(4) Multiple Top-Side Markings will be inside parentheses. Only one Top-Side Marking contained in parentheses and separated by a "~" will appear on a device. If a line is indented then it is a continuation of the previous line and the two combined represent the entire Top-Side Marking for that device.

Important Information and Disclaimer: The information provided on this page represents TI's knowledge and belief as of the date that it is provided. TI bases its knowledge and belief on information provided by third parties, and makes no representation or warranty as to the accuracy of such information. Efforts are underway to better integrate information from third parties. TI has taken and continues to take reasonable steps to provide representative and accurate information but may not have conducted destructive testing or chemical analysis on incoming materials and chemicals. TI and TI suppliers consider certain information to be proprietary, and thus CAS numbers and other limited information may not be available for release.

In no event shall TI's liability arising out of such information exceed the total purchase price of the TI part(s) at issue in this document sold by TI to Customer on an annual basis.

TAPE AND REEL INFORMATION

QUADRANT ASSIGNMENTS FOR PIN 1 ORIENTATION IN TAPE

*All dimensions are nominal

Device	Package Type	Package Drawing	Pins	SPQ	Reel Diameter (mm)	Reel Width W1 (mm)	A0 (mm)	B0 (mm)	K0 (mm)	P1 (mm)	W (mm)	Pin1 Quadrant
LM25007MM	VSSOP	DGK	8	1000	178.0	12.4	5.3	3.4	1.4	8.0	12.0	Q1
LM25007MM/NOPB	VSSOP	DGK	8	1000	178.0	12.4	5.3	3.4	1.4	8.0	12.0	Q1
LM25007MMX	VSSOP	DGK	8	3500	330.0	12.4	5.3	3.4	1.4	8.0	12.0	Q1
LM25007MMX/NOPB	VSSOP	DGK	8	3500	330.0	12.4	5.3	3.4	1.4	8.0	12.0	Q1
LM25007SD	WSOP	NGT	8	1000	178.0	12.4	4.3	4.3	1.3	8.0	12.0	Q1
LM25007SD/NOPB	WSOP	NGT	8	1000	178.0	12.4	4.3	4.3	1.3	8.0	12.0	Q1
LM25007SDX	WSOP	NGT	8	4500	330.0	12.4	4.3	4.3	1.3	8.0	12.0	Q1
LM25007SDX/NOPB	WSOP	NGT	8	4500	330.0	12.4	4.3	4.3	1.3	8.0	12.0	Q1

TAPE AND REEL BOX DIMENSIONS

*All dimensions are nominal

Device	Package Type	Package Drawing	Pins	SPQ	Length (mm)	Width (mm)	Height (mm)
LM25007MM	VSSOP	DGK	8	1000	210.0	185.0	35.0
LM25007MM/NOPB	VSSOP	DGK	8	1000	210.0	185.0	35.0
LM25007MMX	VSSOP	DGK	8	3500	367.0	367.0	35.0
LM25007MMX/NOPB	VSSOP	DGK	8	3500	367.0	367.0	35.0
LM25007SD	WSON	NGT	8	1000	210.0	185.0	35.0
LM25007SD/NOPB	WSON	NGT	8	1000	210.0	185.0	35.0
LM25007SDX	WSON	NGT	8	4500	367.0	367.0	35.0
LM25007SDX/NOPB	WSON	NGT	8	4500	367.0	367.0	35.0

DGK (S-PDSO-G8)

PLASTIC SMALL-OUTLINE PACKAGE

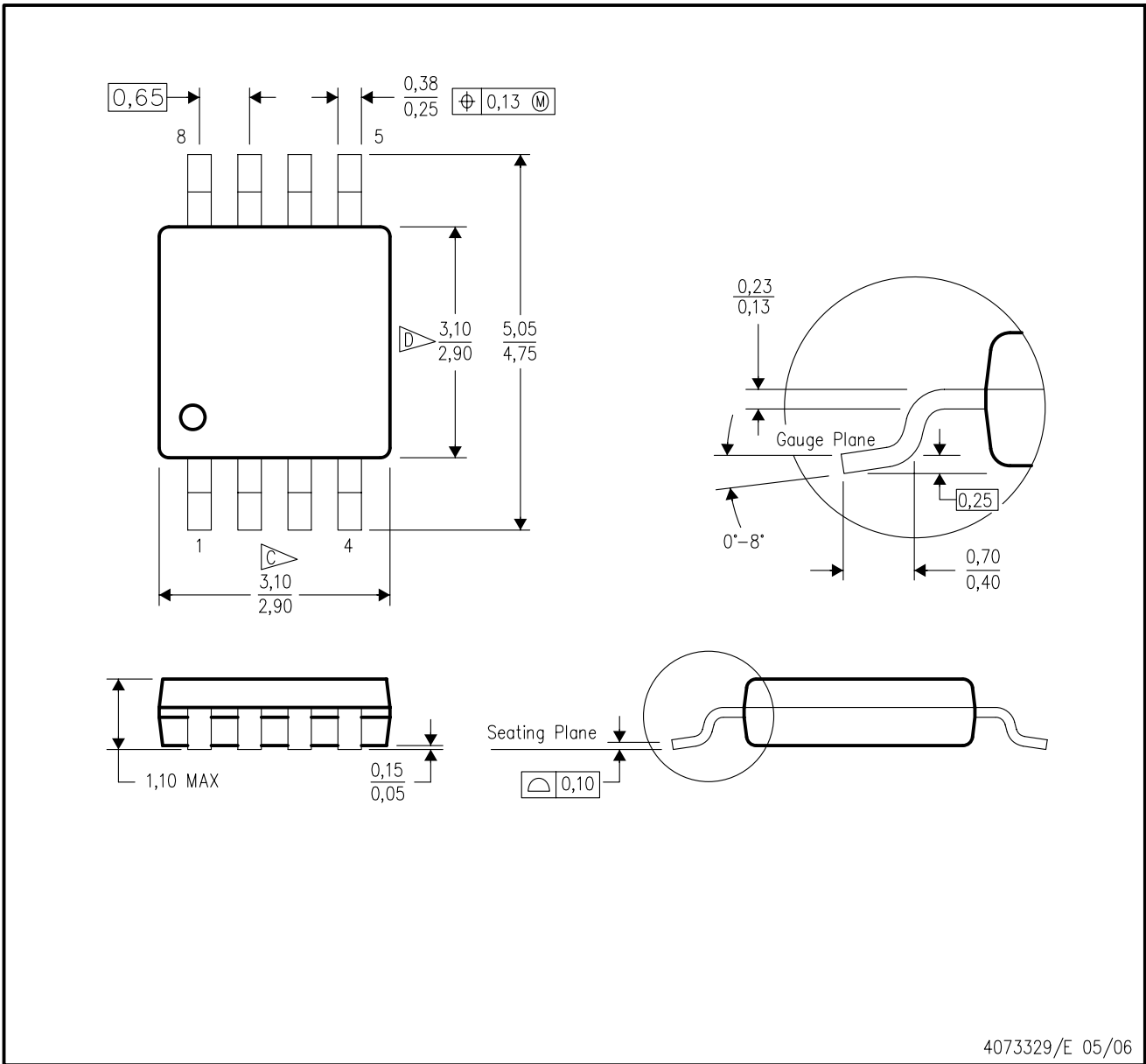

4073329/E 05/06

- NOTES:
- A. All linear dimensions are in millimeters.
 - B. This drawing is subject to change without notice.
 - C. Body length does not include mold flash, protrusions, or gate burrs. Mold flash, protrusions, or gate burrs shall not exceed 0.15 per end.
 - D. Body width does not include interlead flash. Interlead flash shall not exceed 0.50 per side.
 - E. Falls within JEDEC MO-187 variation AA, except interlead flash.

NGT0008A

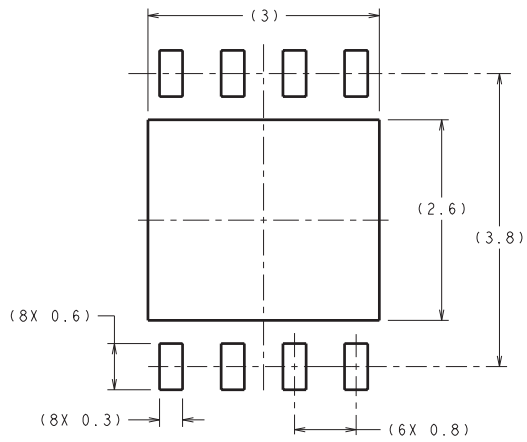

DIMENSIONS ARE IN MILLIMETERS
DIMENSIONS IN () FOR REFERENCE ONLY

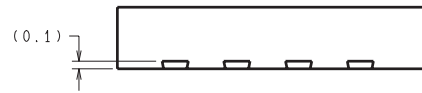

RECOMMENDED LAND PATTERN

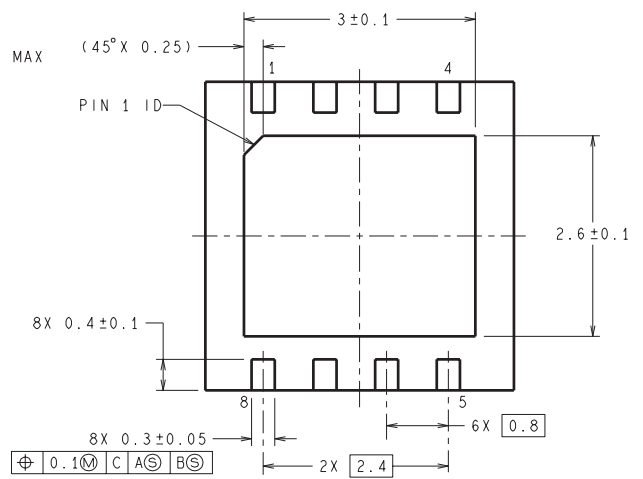
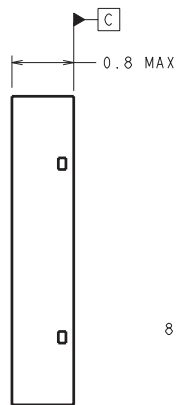
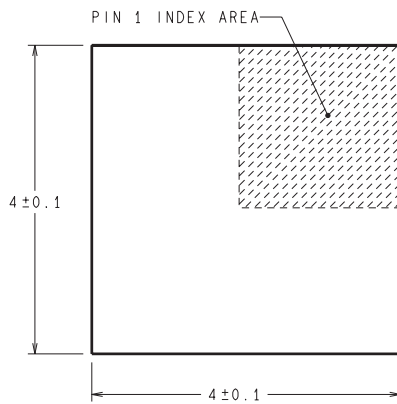

SDC08A (Rev A)

IMPORTANT NOTICE

Texas Instruments Incorporated and its subsidiaries (TI) reserve the right to make corrections, enhancements, improvements and other changes to its semiconductor products and services per JESD46, latest issue, and to discontinue any product or service per JESD48, latest issue. Buyers should obtain the latest relevant information before placing orders and should verify that such information is current and complete. All semiconductor products (also referred to herein as "components") are sold subject to TI's terms and conditions of sale supplied at the time of order acknowledgment.

TI warrants performance of its components to the specifications applicable at the time of sale, in accordance with the warranty in TI's terms and conditions of sale of semiconductor products. Testing and other quality control techniques are used to the extent TI deems necessary to support this warranty. Except where mandated by applicable law, testing of all parameters of each component is not necessarily performed.

TI assumes no liability for applications assistance or the design of Buyers' products. Buyers are responsible for their products and applications using TI components. To minimize the risks associated with Buyers' products and applications, Buyers should provide adequate design and operating safeguards.

TI does not warrant or represent that any license, either express or implied, is granted under any patent right, copyright, mask work right, or other intellectual property right relating to any combination, machine, or process in which TI components or services are used. Information published by TI regarding third-party products or services does not constitute a license to use such products or services or a warranty or endorsement thereof. Use of such information may require a license from a third party under the patents or other intellectual property of the third party, or a license from TI under the patents or other intellectual property of TI.

Reproduction of significant portions of TI information in TI data books or data sheets is permissible only if reproduction is without alteration and is accompanied by all associated warranties, conditions, limitations, and notices. TI is not responsible or liable for such altered documentation. Information of third parties may be subject to additional restrictions.

Resale of TI components or services with statements different from or beyond the parameters stated by TI for that component or service voids all express and any implied warranties for the associated TI component or service and is an unfair and deceptive business practice. TI is not responsible or liable for any such statements.

Buyer acknowledges and agrees that it is solely responsible for compliance with all legal, regulatory and safety-related requirements concerning its products, and any use of TI components in its applications, notwithstanding any applications-related information or support that may be provided by TI. Buyer represents and agrees that it has all the necessary expertise to create and implement safeguards which anticipate dangerous consequences of failures, monitor failures and their consequences, lessen the likelihood of failures that might cause harm and take appropriate remedial actions. Buyer will fully indemnify TI and its representatives against any damages arising out of the use of any TI components in safety-critical applications.

In some cases, TI components may be promoted specifically to facilitate safety-related applications. With such components, TI's goal is to help enable customers to design and create their own end-product solutions that meet applicable functional safety standards and requirements. Nonetheless, such components are subject to these terms.

No TI components are authorized for use in FDA Class III (or similar life-critical medical equipment) unless authorized officers of the parties have executed a special agreement specifically governing such use.

Only those TI components which TI has specifically designated as military grade or "enhanced plastic" are designed and intended for use in military/aerospace applications or environments. Buyer acknowledges and agrees that any military or aerospace use of TI components which have **not** been so designated is solely at the Buyer's risk, and that Buyer is solely responsible for compliance with all legal and regulatory requirements in connection with such use.

TI has specifically designated certain components as meeting ISO/TS16949 requirements, mainly for automotive use. In any case of use of non-designated products, TI will not be responsible for any failure to meet ISO/TS16949.

Products

Audio	www.ti.com/audio
Amplifiers	amplifier.ti.com
Data Converters	dataconverter.ti.com
DLP® Products	www.dlp.com
DSP	dsp.ti.com
Clocks and Timers	www.ti.com/clocks
Interface	interface.ti.com
Logic	logic.ti.com
Power Mgmt	power.ti.com
Microcontrollers	microcontroller.ti.com
RFID	www.ti-rfid.com
OMAP Applications Processors	www.ti.com/omap
Wireless Connectivity	www.ti.com/wirelessconnectivity

Applications

Automotive and Transportation	www.ti.com/automotive
Communications and Telecom	www.ti.com/communications
Computers and Peripherals	www.ti.com/computers
Consumer Electronics	www.ti.com/consumer-apps
Energy and Lighting	www.ti.com/energy
Industrial	www.ti.com/industrial
Medical	www.ti.com/medical
Security	www.ti.com/security
Space, Avionics and Defense	www.ti.com/space-avionics-defense
Video and Imaging	www.ti.com/video

TI E2E Community

e2e.ti.com